



NEW AGE



RELIABILITY and QUALITY MANAGEMENT

R.C. Mishra • Ankit Sandilya



NEW AGE INTERNATIONAL PUBLISHERS

**RELIABILITY
and
QUALITY
MANAGEMENT**

**This page
intentionally left
blank**

RELIABILITY and QUALITY MANAGEMENT

R. C. Mishra

Ph.D.

Professor and Head
Department of Mechanical Engineering
Northern India Engineering College
Lucknow, (U.P.)

Ankit Sandilya

B.Tech.



NEW AGE INTERNATIONAL (P) LIMITED, PUBLISHERS

New Delhi • Bangalore • Chennai • Cochin • Guwahati • Hyderabad
Jalandhar • Kolkata • Lucknow • Mumbai • Ranchi

PUBLISHING FOR ONE WORLD Visit us at www.newagepublishers.com

Copyright © 2009, New Age International (P) Ltd., Publishers
Published by New Age International (P) Ltd., Publishers

All rights reserved.

No part of this ebook may be reproduced in any form, by photostat, microfilm, xerography, or any other means, or incorporated into any information retrieval system, electronic or mechanical, without the written permission of the publisher.
All inquiries should be emailed to rights@newagepublishers.com

ISBN (13) : 978-81-224-2869-8

PUBLISHING FOR ONE WORLD

NEW AGE INTERNATIONAL (P) LIMITED, PUBLISHERS

4835/24, Ansari Road, Daryaganj, New Delhi - 110002

Visit us at www.newagepublishers.com

Preface

Reliability in today's context has gained appreciable importance in the domain of engineering and technology. It is need of the hour as everybody is cautious, while purchasing any product. Therefore its basic knowledge is essential for everyone. Quality is also integral part of reliability and without it, reliability loses its significance. In this book attempt has been made to establish the relationship of quality with reliability in a simple and understandable language. Not much of literature is available to cover the entire subject of reliability and quality together. Books on two topics i.e., reliability and quality are available, but this book bridges the gap between two topics.

The layout of the book includes, principles of reliability, failure statistics, maintainability, reliability mathematics and distribution, reliability data analysis and system reliability. Two separate chapters have been included to discuss reliability aspects related to exclusively electronic equipment/system. Reliability assessment and testing is also the part of the book. Last four chapter elaborate on quality aspects, including, principles of quality, total quality management and ISO 9000 for quality systems.

This book covers up the entire syllabus of reliability and quality management to be taught in the final year B.Tech of electronic engineering and electronic and instrumentation besides some additional information on the subject matter.

Authors acknowledge sincere thanks to Mrs. Urmila Mishra for extending moral support in bringing out this manuscript.

R.C. Mishra
Ankit Sandilya

**This page
intentionally left
blank**

Contents

Preface	v
1. PRINCIPLES OF RELIABILITY	1
Introduction	1
Scope of Reliability	2
Objectives of Reliability	3
The Meaning of Reliability	4
Concept of Overall Reliability	7
Factors Influencing System Effectiveness	8
Questions	9
2. FAILURE STATISTICS FOR RELIABILITY	11
Introduction	11
Failure Classification	11
Causes of Failures	12
Failure Types	15
Failure Investigations	15
Factors Influencing Failure Rate	16
Effect of Design, Manufacturing and Assembly on Failures	17
Failure Data Analysis	17
Failure Rate and its Relation to Reliability	18
Hazard Rate	18
Human factors in equipment failures	19
Questions	19
3. MAINTAINABILITY	21
Introduction	21
Mean Time to Failure(MTTF)	23
Mean Time to Repair(MTTR)	25
Questions	29
4. RELIABILITY MATHEMATICS	31
Introduction	31
Finite and Infinite Sets	36

Empty set	36
Random Variable and its Distribution	41
Failure Distribution	42
Random Variables	42
Questions	43
5. PROBABILITY AND DISTRIBUTION	45
Introduction	45
Concept of Probability	45
Normal Distribution	47
The Log Normal Distribution	49
The Poisson Distribution	49
Exponential Distribution	50
The Weibull Distribution	51
The Gamma Distribution	52
The Binomial Distribution	53
Uses of Distributions	54
Questions	54
6. RELIABILITY DATA ANALYSIS	55
Introduction	55
Reliability Function	56
Bath Tub Curve	58
Data Collection	58
Time Dependent Hazard Models	62
Questions	64
7. RELIABILITY OF SYSTEMS	65
Introduction	65
Series Reliability Model	65
Parallel Reliability Model	66
Series Parallel Reliability Model	68
Decomposed Reliability Model	69
Redundant Reliability Model	69
Markov Reliability Model	71
The Repair/Maintenance Consideration	73
Reliability Indices	74
Questions	77
8. ELECTRONICS SYSTEM RELIABILITY	79
Introduction	79
Reliability of Electronic Components	80
Component Type	81

Contents	ix
Microelectronic Device Failure Modes	83
Circuit and System Aspects	85
Reliability in Electronic System Design	86
Parameter Variation and Tolerances	90
Questions	92
9. RELIABILITY PREDICTION ANALYSIS	93
Introduction	93
Reliability Analysis	94
Reliability Block Diagram	96
Electronic Reliability prediction	97
Tool and Techniques	102
Impact of Working Environment	103
Questions	104
10. RELIABILITY ASSESSMENT AND TESTING	105
Introduction	105
Reliability Prediction	106
The Reliability Data	106
Reliability Models Application	107
Reliability Audit	107
Electrical Stress	108
Reliability Parameter Estimation	108
Reliability Synthesis	109
Life Testing Requirements	109
Sample Size Selection	110
Reliability Test Standards	111
Test Methods and Planning	111
Temperature and Humidity	112
Failure Rate Estimation	113
Reliability Tests	113
Implementation of Reliability Testing	114
Questions	115
11. QUALITY AND RELIABILITY	117
Introduction	117
Quality Control of Products	117
Principles of Quality	118
Quality Control	118
The Concept of Total Quality	119
Process Control	120
Quality Control Charts	120
The Achievement of Quality	121

Quality Management	121
Impact of Quality on Reliability	122
Quality Design Review	122
Quality in Manufacture	122
Quality Tests	122
Questions	123
12. PRINCIPLES OF QUALITY	125
Introduction	125
The Meaning of Quality	125
What is Quality?	126
Characteristics of Quality	127
Quality Policy	127
Statistical Quality Control (SQC)	129
Cost of Control	131
Economics of Quality Conformance	133
Quality Control and Inspection	135
Questions	136
13. TOTAL QUALITY MANAGEMENT	137
Introduction	137
Principles of Quality Management	137
Phases of Total Quality Management	140
Levels of Quality Management	140
Concept of Total Quality Management (TQM)	142
TQM Philosophies	143
Total Quality Management (TQM) Models	148
Objectives of TQM	149
Questions	153
14. ISO 9000 FOR QUALITY SYSTEM	155
Introduction	155
Need for Standardization	155
Levels of Standardization	156
ISO 9000 Series Standards	156
Features of ISO: 9000 Series of Standards	158
Benefits of ISO: 9000	158
Steps to Registration ISO: 9000 Series	159
Questions	161
BIBLIOGRAPHY	163

Principles of Reliability

INTRODUCTION

The word reliability is associated with the civilisation of mankind to compare one item/person with another. Trustworthy, dependable and consistent are the words, which can be used to give an indication of why the characteristic of reliability is valued. Reliability cannot be precisely measured with respect to human behaviour but can give an indication that a particular person is more reliable than the other. The judgement can be easier when it is associated with human behaviour or function. For example, the degree of punctuality of individuals for attending their work place or attending their work without failure can be used to measure their reliability in performing a particular function.

The complexity of industrial systems as well as their products are increasing day-by-day. The improvement in effectiveness of such complex systems has therefore acquired special importance in the recent years. The effectiveness of system is understood to mean the suitability of the system for the fulfillment of the intended tasks and the efficiency of utilising the means put into it. The suitability of performing definite tasks is primarily determined by reliability and quality of the system.

In case of man made products/systems the role of design engineer becomes more crucial to eliminate/minimise the large scale failures to avoid accidents in case of automotive vehicles etc., where risk for human life is involved. The knowledge about long-term properties of material and other devices helps in designing reliable products.

In fact, the characteristic of reliability is usually used to describe some function or task or in widest sense, it may be said to be a measure of performance. A person who completes his work in time is said to be more reliable than the other who does not. Now it is easy to state, that the concept of reliability is not only associated with human behaviour or activity but can also be applied to other inventions of the mankind, by directly measuring their performance or by knowing the failure rates of the equipment/systems. The growing awareness of reliability arises from the fact that there is a need for efficient, economic and continuous running of equipment/system in any organisation for achieving the targeted production at a minimum cost to face the present competitive world. In World War II the need for reliability was felt because of failure of many military operations in spite of the best efforts from the users. After World War II a study was conducted which revealed the following facts:

- (i) The electronic equipments/systems used by the Navy were operative for only 30% of its total available time because of frequent failures/maintenance problems.
- (ii) Army equipments were either under repair/breakdown or commissioning for almost 60-75 % of its total time, which again created problems for a successful mission.

- (iii) Air-force study conducted for about 5 years shown that the maintenance costs were very high and even sometimes many fold of the original cost of the equipments/systems due to frequent breakdowns.

The above facts may be for the reason that during war period the availability of equipments is of prime importance besides its cost. With the above information investigations were further carried out and a concept of reliability group/engineer came into existence. Since then efforts are continuing in this area to achieve the desired goals in industrial organisations. The concept of reliability in the minds of the people/engineers in general has changed their attitude towards the design and manufacturing processes as well. In other words, now the reliability is the concern of every one irrespective of design engineer or process engineer. Even in maintenance also the reliability has its own importance and can yield better results if taken care off.

Reliability Requirements for a System

These can be based on prototypes of a new technical system or based on practical experience for the system in use. This usually requires statistical data about similar objects/items assembled from similar components with expertise and statistics. Ideal conditions for the determination of reliability requirements exist when,

- The system/equipment output can be measured.
- The system structure, operating characteristics etc., are well defined.
- Necessary statistical data for all items/components are determined with satisfactory confidence.

SCOPE OF RELIABILITY

The scope of reliability can be visualised by the following facts in respect of any equipment or system:

- The working environment of the equipment/system.
- The need of safety aspects for men and material.
- Degree of uncertainty about the success of operation and its improvements in system/equipment performance.
- Need for efficient, economic and continuous running of equipment/system without disturbances.
- A failure of an equipment/system raises the question in the minds of the people regarding its reliability and its further use.
- Improvement in the confidence of the working personnel particularly in the hazardous area because of safety reasons.

Any equipment/system manufactured is designed with certain objectives to meet its goals in terms of production/service. With passage of time or environmental conditions the equipment may not give the desired results over a period of time. This system may be treated as unreliable. Therefore, a reliable equipment is the one which works for a given stipulated time period under given environmental conditions without interruptions. In general terms, if the failures are unpredicted and more in number, the equipment/system is said to be

unreliable and its market value is reduced. On the other hand if the number of failures are less, then the equipment/system is reliable and its market value is high. The term risk is associated with frequent failures of equipment and to a large extent is a qualitative in nature and attempts are being made to assure its quantitative measure. It tries to combine the probability of something going wrong and consequences of the event. Now the problem is to assess these consequences. In certain cases it is easy and straightforward, whereas in some cases it is difficult to measure it. Keeping this in mind the risk can be defined as the product of its frequency and the magnitude. The frequency here means the failure of the equipment per unit time. These failures can occur due to various reasons depending upon the working conditions, operator skill and other such parameters.

To know the real scope of reliability it is required to highlight some technological systems, which need high reliability. The application of reliability becomes more dominant where risk factor is high and capital involvement is at stake with human life. The first in this class falls the aerospace systems mainly aircrafts. It is known that capital investment in case of aircrafts is very high and also human lives are at risk, the systems used must be highly reliable. The other area where high reliability is required is the nuclear power plant. If such plants are not available for power production, they incur heavy loss per hour as well as the good will of the concerning people. The radiations from such plants can cause havoc, due care has to be taken during the discharge of their by-products. Two main types of equipment failures normally affect the reliability of such systems. First of all the 'fail dangerous', and secondly the 'fail safe'. The fail dangerous will protect the system in case of any fault, whereas in fail safe mode the system will be shutdown in case of any fault. The above two systems must be highly reliable to avoid any mis-happening. Safety circuits can also be provided for the whole protective system. It is desired that the protective systems should shutdown the plant in case of serious fault where protection device fails.

The other highly reliable systems include chemical plants, process industries and electric supply systems where the failures can cause high revenue losses. Although the safety of human is not at stake in these cases but inconveniences are caused to the users. For example, running of electric trains can be badly affected by unreliable power supply.

OBJECTIVES OF RELIABILITY

During the design phase of any product/system, it is desired that the said system should meet the performance standards as expected within the specified constraints. These constraints include cost of equipment/product, environmental conditions and availability of material/parts etc. A system/equipment normally comprises of many units/components and their interconnection and integration should result in satisfactory performance. The number of components and units make a system complex and therefore, system is dependent on complexity of the functioning of the units. It is further more difficult to achieve satisfactory performance from such system/equipment. Therefore, the objectives of reliability are many fold and include the following:

- (i) Trouble free running of system/equipment
- (ii) The adequate performance for a stated period of time
- (iii) The equipment/system should work under the specified environmental conditions

- (iv) Minimisation of downtime of equipment/system and
- (v) Maintainability of device/components.

THE MEANING OF RELIABILITY

Any equipment/system after its manufacture or fabrication is tested under actual working conditions, and where actual conditions are not possible the concept of simulation is applied. It is desired from the equipment /system that they perform within the specified limits. If the product/system survives the tests, the reliability R of the equipment can be defined as the probability that the product continues to meet the given specifications over a given period of time subjected to environmental conditions. However, if the product does not meet the specifications as desired over a period of time it is considered as failed in its mission. The unreliability ' F ' of the product can be defined as the probability that the product fails to meet the specifications over a given time period under the given environmental conditions. The failures can occur due to many reasons known or unknown such as wear, mechanical fracture and chemical corrosion etc.

The reliability and unreliability are dependent on time. At time zero when the product/equipment is put into service its reliability is unity, after certain time interval it may be 0.5 and zero when the equipment, system fails. On the other hand unreliability increases with passage of time i.e., when the products tested and put into the service its unreliability is zero. With passage of time it may increase to 0.5 and finally to unity when the equipment/system fails. Since, at any time ' t ' the product has either survived or failed, therefore the sum of reliability and unreliability must be unity i.e., the two events are complementary and can be expressed by the equation below:

$$R(t) + F(t) = 1 \quad \dots(1.1)$$

Where (t) is the expected time period of equipment/system in use under the given environmental conditions?

Besides the quality of product, maintenances play an important role to improve the reliability. The high quality product may have high reliability, whereas reverse may not be true i.e., high reliability product may not be of high quality but it meets all specifications as desired for its operation.

Now we can establish relationship between quality and reliability. The reliability of a product is its ability to retain its quality during its usage. If the quality of the product is maintained with passage of time its reliability will also be maintained. The quality again can be kept intact with the use of better maintenance practices.

Definition of Reliability

The basic definition of reliability states that it is the probability of a device to perform its intended functions over a pre-specified time period under the given environmental conditions. Thus, the important factors associated with the reliability are probability, intended functions, time period and the working conditions.

Since, the reliability is expressed as probability, its value will vary from zero to unity thereby giving quantitative measure. In our daily life we compare one product over the other for its superiority in terms of either dependability or reliability. The degree of superiority can only be expressed in quantitative terms. The pre-mature failure of a product/system will help

to establish the creditability of manufacturer for the superiority/quality when compared with other manufacturer for the same product. It is generally said that the product of *A* is superior to that of *B* based on the above statement. The ordering of the products can also be specified in quantitative terms as per their reliabilities.

The second aspect namely the intended functions can be expressed easily for some products such as electric/electronic devices, whereas it is difficult to specify the same when the product is complicated. For example, a turbine, which includes many components. For such devices the overall performance has to be examined in terms of reliability. Larger the system, the complications will increase many fold, because in a failed unit (turbine) some components will always be operative. But the failed unit will not allow the working of the equipment. Therefore, for reliability evaluation unit is to be considered as a whole, though made up of many components/parts.

The time period for which the reliability assessment has to be carried out is a complicated issue until and unless it is specified properly based on the past experience it may cause problems. For mechanical equipment it is easy to state the time limit since their failures are gradual in nature whereas, for electrical and electronic equipment it is really difficult since their failures are unpredictable and reasons for failures may be many.

For complete definition of reliability it is essential to know the following terms associated with it.

- **Total up time:** It is the period for which an equipment/system remains operational without any failure.
- **Mean time to failure:** It is the time period between the failures of equipment/system i.e., time of first failure to the next one.

Mean Failure Rate: The failures occurring over a time interval can be expressed as a mean failure rate. If there are N components in service for time T , then failure rate is N/T .

The total number of failures which have occurred or likely to occur in a particular equipment or system are of interest and could be used as some index of reliability.

For practical definition of reliability two cases can be considered where reliability calculations are independent of time.

Non-Repairable Items

In this case once the item fails it is to be replaced. Let us consider that there are N products placed in service with a test interval of T . The i th failure takes place at time T_i . The total up

time with N failures is, therefore, $\sum_{i=1}^N T_i$, and the Mean Time to Failure (*MTTF*) is given by:

$$MTTF = \frac{1}{N} \sum_{i=1}^N T_i \quad \dots(1.2)$$

The mean failure rate $\bar{\lambda}$ is expressed as:

$$\begin{aligned} &= \frac{\text{Number of Failures}}{\text{Total up Time}} \\ \bar{\lambda} &= \frac{N}{\sum_{i=1}^N T_i} \quad \dots(1.3) \end{aligned}$$

MTTF can also be expressed in terms of reliability:

$$MTTF = \int_0^{\infty} R_t(dt) \quad \dots(1.4)$$

Here ∞ means N being infinite.

Repairable Items

In this case items/products can be repaired, which involves down time of the product as it needs some time to repair. The down time T_{Dj} is associated with j th failure is the total time between the occurrence of the failure and the repaired item being put back into operation. The total down time for N_F failures therefore is $\sum_{j=1}^{N_F} T_{Dj}$ and Mean Down Time (*MDT*) is given by:

$$MDT = \frac{1}{N_F} \sum_{j=1}^{N_F} T_{Dj} \quad \dots(1.5)$$

The total up time can be found out by subtracting total down time from NT and is expressed as:

$$\begin{aligned} \text{Total Up Time} &= NT - \sum_{j=1}^{N_F} T_{Dj} \quad \dots(1.6) \\ &= NT - N_F MDT \end{aligned}$$

Where N_F is total number of failures.

The Mean Time Between Failure (*MTBF*) can be expressed as:

$$\begin{aligned} MTBF &= \frac{NT - N_F MDT}{N_F}, \text{ and mean failure rate } \bar{\lambda} \text{ is given by,} \\ \bar{\lambda} &= \frac{N_F}{NT - N_F MDT} \quad \dots(1.7) \end{aligned}$$

It clearly shows that mean failure rate is reciprocal of *MTBF*.

Reliability and Quality

The definition of reliability has been discussed in the earlier paragraphs. However, its relationship with quality is very old i.e., inception of any product/service. Quality and reliability go hand-in-hand and are complementary of each other. Without quality there is no reliability. For a product or service to have higher reliability, it must have good quality as well.

The quality of a product/service is the degree of conformance to applicable specifications and workmanship standards. It is not concerned with the elements of time and environment. An equipment which has undergone all quality tests may not necessarily be more reliable. Quality is associated with the manufacture whereas, reliability is basically associated with design/material. In a way reliability of the product is the ability of the unit to maintain its quality under specified conditions for a specified time period.

The "intended function" of the product/service is related to the quality. For example, an electric generator is expected to provide an output of 5 kW at 220 V under certain conditions which is the intended function of the generator. Any deviation in any of the two parameters will be termed as the failure of the generator. This may happen today or any time in future.

Environmental conditions such as temperature, humidity, vibrations etc., affect the quality and in turn cause the failure of the equipment/service under operation. Any change in the operating parameters may also cause failure. Therefore, operating conditions including environment play important role so far quality and reliability of the products/services is concerned.

Another important difference between quality and reliability is that one can build a reliable complex system using less reliable components but it is impossible to construct a 'good' quality system from 'poor' quality components. This is mainly due to the reason that reliability can be improved using redundant component/system. But the quality of the product cannot be improved after it has been manufactured/fabricated. It is only possible through modification of the product.

CONCEPT OF OVERALL RELIABILITY

The performance of a system can be defined in two ways, firstly the required performance, which indicates that what a system is supposed to do under all environmental conditions and secondly, the achieved performance which the system is likely to do under all environmental conditions. Overall reliability is a measure of the relationship between the complete achieved performance of the system against the corresponding required performance under all environmental conditions of space and time. Therefore, correlation of required performance and achieved performance makes the basis of the overall reliability concept and these two measures of performance may be probabilistic in nature because of their dependence on the input conditions.

In real life situations, the likely performance may have variability when different readings are taken. Under such a situation a frequency table is made to draw histograms. With larger number of variates, the histogram, which was in rectangular form, approaches some smooth curve.

The achieved performance can further be sub-divided to consider both capability of performance and variability of performance. The lack of capability may arise not only from an error in the assumed input conditions but also from any inherent design problem in the equipment itself. If by mistake incorrect data are fed to the system, the obtained reliability will also be incorrect.

The existence of variability in any practical system indicates that the value of the reliability may lie between 0 and 1 but never unity. The variations may be predictable, random or combination of both.

The following processes are essential to evaluate the reliability of a system.

- Establishment of the precise required performance of the system under all environmental conditions.
- Analysis of system to determine its inherent capability.
- Variation analysis to establish complete variability function i.e., distribution of variation.

- The process of fault mode analysis to determine availability.
- A process to obtain a particular reliability value over the appropriate time with the help of the above steps.

FACTORS INFLUENCING SYSTEM EFFECTIVENESS

The system/equipment effectiveness is indirectly related with the reliability because reliable system will help the operating personnel more effectively. If the system is effective its performance can be improved for satisfaction of the customers. An equipment may be in working condition giving sub-standard performance will not be accepted because of its poor system effectiveness. In the present day environment, the customers desire to optimise on their investments with all possible effectiveness of the system. The system/equipment will be influenced by the following factors.

- (i) Availability of the system/equipment
- (ii) Complexity of devices/components
- (iii) Maintainability
- (iv) Maintenance system practiced
- (v) Maintenance support system
- (vi) Failure history of the equipment/system
- (vii) Coordination and cooperation of maintenance staff and operating personnel.

Evaluation of System Effectiveness

In case of complex systems, redundant units are internally built in to help the equipment to perform their main function. Some systems can perform the same task by several different means. In this case failure of a unit can lead to decreased performance but complete system does not fail. Thus, a complex system can require measure of capability that can take partial failure into account.

Effectiveness can be used to measure the performance of the system in quantitative manner. For example, quality of fuel used in IC engines can lower its performance, or poor quality service in cafeteria can lower the number of customers. The system can be said more effective with higher effectiveness index number, which can be set for different types of systems.

Cost of Reliability

It is well known that the cost of product/service increases depending upon its reliability requirements. Therefore, a cost-benefit analysis is essential to design and manufacture product at a optimum cost. The figure given below shows the total cost when reliability concept is incorporated in a particular product/system.

It is observed from the figure that quality/reliability cost increases with higher requirements of reliability. Each failure has a cause and it is important to know, what is the cost of preventing or correcting the cause, compared with the cost of doing nothing. Initial high cost of achieving reliability can be compensated by minimising the failures.

Achieving reliable designs and products requires a totally integrated approach, including design, training, test, production, as well as the reliability programme activities. It places high

requirements for judgement and engineering knowledge on project managers and team members.

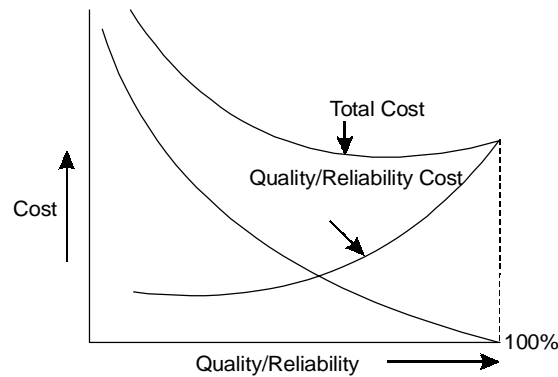

Fig. 1.1 Reliability/Quality Costs

- Failures are caused primarily by people (designers, suppliers, assemblers, users, maintainers). Therefore, the achievement of reliability is essentially a management task, to ensure that right people, skills, teams and other resources are applied to prevent the creation of failures.

- Reliability (and quality) are not separate specialist functions that can effectively ensure the prevention of failures. They are the results of effective working by all involved.

- There is no fundamental limit to the extent to which failures can be prevented. We can design and build for ever-increasing reliability.

While considering the whole product life cycle, efforts be made to ensure that designs are intrinsically reliable, by good design and effective development test etc. The concept of continuous improvement is more effective when applied to up-front engineering.

QUESTIONS

1. Explain the basic principle of reliability with its need in the modern industrial setup.
2. Discuss how reliability can be useful in the changing industrial system.
3. What is reliability? How it can be applied to the existing system?
4. Define availability with its importance to maintenance organisation.
5. Discuss the concept of overall reliability.
6. Enlist the factors responsible for system effectiveness.
7. Highlight the importance of cost of reliability.
8. Define reliability, quality and availability.

**This page
intentionally left
blank**

Failure Statistics for Reliability

INTRODUCTION

The equipment/system, which, are designed and manufactured with lot of precautions and care cannot work continuously for infinite time period. And therefore, failures are bound to occur which will make the equipment completely inoperable or it can work with reduced efficiency. With passage of time elements/components get deteriorated and may fail subsequently if not checked. In reliability analysis, the word failure is used when the equipment/system is not available for use or service. For reliability evaluation, the failure rates of elements/components are essential. Before discussing their details it will be pertinent to know the types of failures, their causes and recording of relevant information. This chapter will highlight the need of failure data collection, processing and making them suitable for reliability calculations.

FAILURE CLASSIFICATION

Failure classification may be viewed from different aspects according to the effect it will have on the overall performance of the equipment/system. Broadly failures are classified as:

- (i) System failure, and
- (ii) Component failure.

In some cases failure of component/element may make the equipment/system completely inoperable and the same cannot be used without repairing the failed component. This is mainly possible in case of high risk equipment/system for example, airplane equipment. Even in case of automobiles, the failure of brakes will make it inoperable and therefore, this will fall in the category of system failure. On the other hand failure of a component/element may not make it fully inoperable and the equipment/system can be used with reduced performance. Failure of lights in an automotive vehicle does not make it fully inoperable, the system can be effectively used in daylight. When the elements/components are placed in series, failure of one will make the system completely inoperable. Whereas, when the same are placed in parallel, failure of one element/component may not render it completely inoperable. The system can work but its performance may be reduced. The failure of one of the cylinders in a multi cylinder engine will fall under this category. This type of failure can be classified as component failure.

The engineering classification of failures may have:

- (i) Intermittent failure, which may result in lack of some function of the component only for a very short period of time, and

- (ii) Permanent failure, where repair/replacement of component will be required to restore the equipment to operational level.

When considering degree of failures, it can be classified as:

- (i) Complete failure, where equipment/system is inoperative and cannot be used further, and
- (ii) Partial failure, which leads lack of some functions but the equipment/system can be used with care, may be with reduced performance.

Some failures can be sudden and cannot be anticipated in advance, whereas, the gradual failures can be forecast during inspection/testing, which follows the part of the condition monitoring.

Other classification of failure can be:

- (i) Catastrophic failures, which are both sudden and complete;
- (ii) Degradation failures, which are both partial and gradual.

CAUSES OF FAILURES

The followings are the major causes of failures, which normally occur in engineering equipment/systems:

(i) **Design Deficiencies:** All the performance related parameters couldn't be visualised fully during the design phase. Some of the factors considered during design may not be conducive for the proper functioning of a component and the same may cause failure. These factors can be identified during the performance testing of the equipment/systems. Such factors contribute towards the design deficiencies; however, the same can be incorporated during the redesign phase of the element/component. The various reasons for such deficiencies are the following:

- (a) It is observed in practice that notch formation in the components/parts create problems due to high concentration of stresses at these points. Such problems are noticed on the machined parts during reduction in their dimensions, the common example being the shaft. Here, the keyways are also subjected to high stress concentration and will be prone to failures.
- (b) During redesign stage if proper precautions are not taken, due to high stress concentration zones, the components may have premature failures. For example, if the holes drilled in an existing part, may have sharp corners, which will form high concentration regions and will constitute the deficiency in design.
- (c) During use of equipment, upgrading of parts/components, etc., becomes desirable which may not match with the original design to meet out the new loading conditions of high temperatures, corrosive atmosphere even lack of proper heat treatment. These all again fall in the category of design deficiencies.
- (d) During the design phase, it is difficult to assess the actual loading conditions or forces to which a part of element will be subjected too, since, the same are designed for optimum working conditions. The basic concepts in design include lightweight and minimum cost or sometimes the geometry of the component/element may play an important role. Because of the geometry of the component design deficiencies are very common.

(ii) **Material Selection:** In actual practice, it is generally noticed that maximum failures are due to improper selection of materials, as they do not fulfill the design requirements. The tests, which are carried on the standard material but in actual manufacturing the same may not be used. During design it is believed that the material is homogenous but in real life situation it is not true. Some materials are good either in tension or in compression, but the same may be used where both above conditions do exist. The common example is the beam, which is subjected to tension as well as compression. The imperfection of materials may also cause premature failures because of propagation of cracks in certain areas. Therefore, the selection of proper material for the real working conditions is of paramount importance.

(iii) **Manufacturing Process:** Dimensional analysis is very important during the design phase to know the stresses to which a particular job will be subjected. In actual manufacturing, it is really difficult to maintain the design dimension tolerances, which again will lead to premature failure conditions. The process of manufacture i.e., machining, welding, grinding, etc., will play important role for the desired performance of the component/element. During manufacture of an item by machining the surface temperatures are likely to vary, which will change the surface characteristics of the material. Some undesired marks, indentation, etc., are the potential source of failure of a component due to formation of cracks during use. Even improper heat treatment may cause surface irregularities which in due course of time may lead to premature failure.

During assembly of parts, due to inaccurate/incomplete specifications may cause early failure of components. Misalignment of the parts resulting in bent shafts, bearings seals, etc., may be one of the primary causes of failure of the assembled parts/components.

The improper service conditions will also affect the rate of failures. Through proper checking, inspection and monitoring the failure rate under such working conditions can be minimised. When newly assembled parts are put in service for the first time, due care should be taken for the unexpected working conditions for example, steep rise in temperature or even slight misalignment. A rapid increase in the speed or sudden rise in pressure may lead to severe damage.

The causes of failures can be many but a few of them are given as under:

- (i) Wear out failures, where failures are due to normal wear and tear of the parts as expected due to use of the equipment/system.
- (ii) Misuse failure, these failures can be the cause of over-stressing the component/part beyond their capabilities, and
- (iii) Inherent weakness failure, these failures are associated during the design and manufacturing of the equipment/system.

In other words the broad classification of the failures can be as follows:

(a) **Service Failure:** In most of the machinery/system the failures experienced are fracture, excessive deformation and surface failures particularly corrosion. These failures are normally time-dependent and can be checked during inspection and maintenance. Sometimes non-destructive techniques (NDT) may be needed to trace the failures without even dismantling the component.

(b) **Fatigue:** This type of failure occurs when the loading is cyclic in nature and where cracks initiates and grow, which cause failure of the components/parts. Though the fatigue limits are

set in advance but the operating conditions may influence an early fatigue failure. In some important equipment fatigue metres are attached for monitoring the condition of the system regularly to avoid accidents.

Basically, fatigue starts with the formation of micro-cracks, which may be due to surface roughness or any other reason and are limited to surface grains only. Due to cyclic loading, these micro-cracks propagate and sometimes lead to fatigue failure of the equipment.

The other reason for fatigue can be stress concentration, which may originate from geometrical configurations; however, their values can be determined to avoid failures. Changes in shape may also lead to stress raisers, which may be deliberate due to design requirement or due to manufacturing defects. The more common stress raisers are notches, de-carbonisation corrosion, inclusions, internal stress and clamping devices used during manufacture of products.

Surface fatigue can also occur due to heat treatment and rolling loads particularly in ball bearings. Metallurgical changes have limited effect on fatigue life of products. The principle factors are grain size, microstructure and orientation. The vibration in a system may be the prime cause of fatigue failure.

(c) **Excessive Deformation:** The components/parts are normally subjected to static, dynamic and fluctuating loads. Static loads may be applied gradually or suddenly. Under gradual loads equilibrium of parts is easy to maintain whereas in case of dynamic are fluctuating loading conditions, the components/parts are required to move, which produces inertia forces. If these inertia forces are not properly balanced, will generate severe vibrations and ultimately deformation of the parts/structure.

(d) **Wear:** Wear is a common phenomena between two surfaces in contact and will cause surface deterioration in the form of micro-cutting, plastic and elastic deformation, surface fatigue, local heating, oxidation, etc. With the use of lubricants micro-cracks are excessively pressurised which leads to damage of the surface layers.

The wear in actual form can be classified as under:

- (i) Abrasive wear, which is caused by ploughing or gauging hard particles against the soft working surfaces. It is quite obvious that the softer material will wear out more than the hard material.
- (ii) Scuffing can occur when ideal hydrodynamic lubrication cannot be maintained under sliding conditions. Under these conditions, the lubricant layer formed between the matting surfaces break off.
- (iii) Fatigue wears. This occurs in rolling friction and is caused by fatigue of the surface layers.
- (iv) Molecular wear occurs when two matting surfaces are subjected to high pressures.
- (v) Mechanical oxidation wear is caused when the surfaces are exposed to oxidation process in equipment/system.
- (vi) Cavitations can be caused when surface is acted upon by a fluid flow with local hydraulic impacts.

(e) **Corrosion:** Corrosion mainly occurs when the equipment/system is subjected to humid conditions and it gradually makes the surface weak and can fail after sometime. The corrosion activity normally depends upon the working environment and can be identified as stress corrosion fatigue or cavitations.

The stress corrosion takes place when stresses are applied on the equipment/system when it is placed in humid atmosphere. This takes place in the form of cracks where material is not even subjected to plastic state. Under fluctuating load conditions where components/parts are placed in corrosive atmosphere, the corrosion fatigue takes place. Whereas the cavitations occurs with the collapse of minute vapour bubbles mainly when the equipment is working in a corrosive environment.

(f) **Blockage:** When fluid flow takes place in any system, it is likely to get blocked due to formation of sludge's in the fluid. This is mainly found in cooling towers and radiators of internal combustion engines. These blockages create excessive pressure on the surface and cause it to fail.

FAILURE TYPES

Basically failures are defined as the termination of the ability of a component/part to perform its required functions. The failure of component/system can be classified in many ways, which may include the following:

- (i) Catastrophic failures are ones which immediately stops the working of system/equipment and it cannot be used without proper repair/maintenance.
- (ii) Performance failure. These are related with the performance of the equipment/system. This system may remain operative in the failure of some components/parts but its performance decreases, which is true for the most of equipment used in engineering application.
- (iii) Deliberate failures are caused either by the neglect of the operating personnel or by his ill intention to make the equipment inoperative for sometime/period. In this case operators make excesses, which are not rational for example, application of brakes in an automobile.

Basically, the failures fall under the following categories:

- (i) Infant or early failures. It can be seen from bath-tub curve, that due to quality of components some equipment, fail during their initial life and such failures number can be high. These failures can also be due to initial turning of the system.
- (ii) Random failures, which can take place at any time due to unforeseen reasons and it is difficult to predict them. Their causes could be extra stress on the component or the quality of material. However, these failures can be minimised through a proper investigation of load and quality of material in use.
- (iii) Time-dependent failures where mean time to failures can be predicted since the failures depend on the usage of the equipment/system. Hence, failure distribution can be plotted to know the frequency of failures, which can be used to control the rate of system component failures.

FAILURE INVESTIGATIONS

The technical investigation of failed equipment is sometimes essential to obtain information to know the cause of failure. This information can be utilised only to control further failures but

also to bring out some improvement/modifications in the system. However, the correct information can only be had if the investigations are carried out just after the accident/failure and the evidences are not destroyed or distorted. For the same reason investigations are carried out after any major accident to avoid re-occurrence.

FACTORS INFLUENCING FAILURE RATE

The following factors are most important for the failures of equipments/systems and therefore should be given due care in the design and manufacturing phase of the equipment:

(a) **Quality:** The quality of parts depends on the quality of material used. If the quality of components is higher, will lower the failure rate and will increase the cost of equipment/system. This is more pertinent, where reactive materials are used. For example, if acid is to be used, the material should resist its reaction otherwise the component will fail before the scheduled period.

(b) **Temperature:** The failure rate of electronic components is highly dependent on the temperature of the component. The relationship is expressed as:

$$\lambda = Ke^{(-E/kt)} \quad \dots(2.1)$$

λ = Component failure rate (constant)

T = Component temperature in K

E = Activation energy of failure process (eV)

k = Boltzmann's constant = 863×10^{-5} eV/K

K = Constant.

The failure rate depends on activation energy, (i.e., higher the energy, higher is the failure rate). However, the temperature of components/parts also depends upon the surrounding temperature. The electrical insulation properties of materials change at both high and low temperatures. Corrosion also increases with rise in temperature. Even the wear rate of mechanical component also increases with rise in temperature. Viscosity of the fluids also changes with the change in temperature.

(c) **Environment:** Temperature is one of the examples of environment factors, which affects the failure rate of components. The other environmental factors include, humidity, salt and dust in atmosphere, exposure of frost, nature of process material, vibration, mechanical shock, thermal shock and electromagnetic radiation. Even one environmental factor is enough to cause an early failure but two of these factors may aggravate the failure rate to a greater extent, example is the presence of salt with humidity, which causes corrosion.

The failure rate of instruments in contact with process fluid is significantly higher than those in contact with the background plan environment. Even the cleanliness of the fluid will affect the failure rate.

(d) **Stress:** In a mechanical system such as beam or strut which are subjected to stresses, produces corresponding strain greater than the elastic limit of the material, the material is likely to undergo plastic deformation and fail. It is, therefore, needed that the strain caused in

a material due to application of load should not exceed elastic limit to avoid failure. For this reason only limits are fixed for a load carrying system and factor of safety is used during design stage.

EFFECT OF DESIGN, MANUFACTURING AND ASSEMBLY ON FAILURES

Apart from operational causes for premature failures of component/system, the deficiencies of design, manufacture and assembly can also attribute towards early failures. Faulty design, where proper care has not been exercised for correct loading and other related factors could cause premature failure. However, manufacturing faults causing failures can be minimised through quality control techniques. The analysis of failures would indicate the nature of such failures.

Incorrect assembly of component/system is a critical cause of failure, which can occur during manufacture or even after servicing/repair. Proper care for limits tolerances can reduce the assembly failure.

FAILURE DATA ANALYSIS

For the evaluation of reliability, the information about failures of component/elements is essential, which either can be obtained through experiments or through simulation. Tests are carried out on identical items to study the failure behaviour of the components. Which provide failure data, to give the number of events taking place as a function of time for a particular equipment/system.

Let 'n' be the number of failures that occur in time, $T = t$, then probability of failure in time, $T = t$ is expressed as $F(t)$ and is given by:

$$F(t) = L_t\left(\frac{n}{N}\right) \text{ as } n \rightarrow \infty \quad \dots(2.2)$$

Where, 'N' is the number of specimens tested. A plot between $F(t)$ and time T , is given below:

Which indicates that $F(T=0) = 0$, $F(T=\infty) = 1$. With the assumption, that the N is large. The probability of failure occurring within time $T = t$ is $F(t)$, and the probability of failure occurring within time $T = (t + \Delta t)$ is $F(t + \Delta t)$. Hence, the probability of failure between time, t and $(t + \Delta t)$ is given by:

$$F(t + \Delta t) - F(t) \quad \dots(2.3)$$

The above equation gives probability of failure occurring in $(t + \Delta t)$ interval at $T = t$. If this equation is divided by Δt , it gives the probability of failure occurring in a unit interval of time at time $T = t$, i.e.,

$$\frac{1}{\Delta t} [F(t + \Delta t) - F(t)] \quad \dots(2.4)$$

Where, $\Delta t \rightarrow 0$ we get

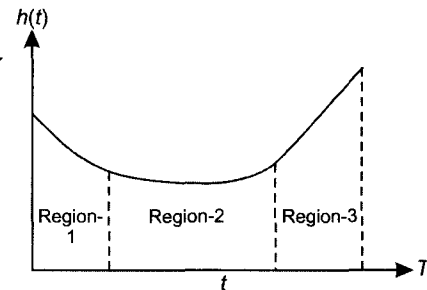

Fig. 2.1: Failure Pattern with Time

$$L_t \frac{[F(t + \Delta t) - F(t)]}{\Delta t} = \frac{dF(t)}{dt} \quad \dots(2.5)$$

This equation represents the failure density function $f(t)$ and is the slope of $F(t)$ curve at function of time:

$$f(t) = \frac{dF(t)}{dt} \quad \dots(2.6)$$

FAILURE RATE AND ITS RELATION TO RELIABILITY

The failure rate is defined as the probability that a failure per unit time occurs in the interval (t_1, t_2) given that a failure has not occurred prior to the beginning of the interval t_1 , the interval failure rate (FR) is expressed as:

$$FR(t_1, t_2) = \left(\frac{1}{t_2 - t_1} \right) \frac{R(t_1) - R(t_2)}{R(t)} \quad \dots(2.7)$$

Where, $R(t)$ is the reliability at a given time period. When the time interval $(t_2 - t_1)$ approaches zero the failure rate is called as the instantaneous failure rate. It is also termed as hazard rate or hazard function and can be expressed as:

$$h(t) = \frac{1}{R(t)} \frac{dR(t)}{dt}$$

Which be expressed as:

$$h(t) = \frac{f(t)}{R(t)}$$

Where $f(t)$ is the probability density function.

The difference between $h(t)$ and $f(t)$ is that $h(t)$ is the rate of change of conditional probability of failure given survival time ' t '. Whereas, $f(t)$ is rate of change of unconditional probability of failure, the hazard rate indicates the change in the failure rate over the lifetime of the component/element. If $h(t)$ is increasing in $t > 0$, then $f(t)$ is said to be increasing failure rate and vice-versa.

HAZARD RATE

The typical graph showing hazard rate is called as bathtub curve. This curve shows three distinct regions being 1, 2 and 3. The region 1 shows pre-mature failures due to material or manufacturing defects, which can be minimised by better quality control. The second region is termed as random failure with horizontal curve indicating that the failures are constant in nature and may be due to fluctuating stresses under operating conditions. For these failures due care is taken in design phase. The third region is termed as wear out failure zone where failures are due

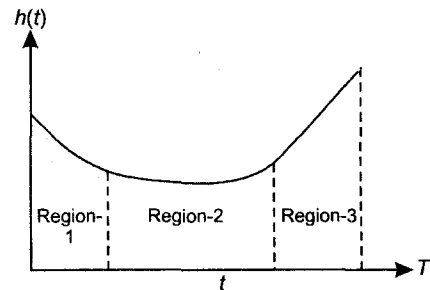

Fig. 2.2: Hazard Rate

to fatigue deterioration and stresses, etc., and are caused due to prolonged use of the equipment/system. The failure rate under this region increases rapidly. The figure given below is for electrical/electronics components which relatively have longer useful life period. However, for the mechanical components the curve is slightly different and useful life period is short.

HUMAN FACTORS IN EQUIPMENT FAILURES

Mechanical failures can be known in advance with its reasons. However, the human factor is highly important factor in accidents and is well known to the organisations involved in insurance activities for example, automobile industries. Studies carried out in this area have highlighted the human factors needing attention during the accident. The attention should be given to the effects of 'boredom' group interaction, lack of instructions, incorrect motivation, ill defined area of responsibility, poor control, poor communications and many similar causes of irrational behaviour.

Fault Detection Sensors

To identify the faults during scheduled maintenance or check-up to examine physical or chemical change, various sensing devices are being used and include X-ray fluorescence, corrosion metres, load cells, transducers and strain gauges etc.

QUESTIONS

1. How failures are classified? Explain it briefly.
2. What are the main reasons for failure of system? Discuss.
3. Explain, how failures can be investigated in components/systems.
4. Highlight the influencing factors associated with failures.
5. With the help of an example explain data failure analysis.
6. What is the significance of hazard rate in mechanical systems?
7. Write the importance of human factors in equipment failures.
8. Define hazard rate. Explain their application to the reliability of components and repairable systems. Discuss the plausibility of the 'Bath tub curve' in both contexts.

**This page
intentionally left
blank**

Maintainability

INTRODUCTION

Maintainability is a characteristic of equipment design and installation which is expressed in terms of ease and economy of maintenance, availability of equipment/system, safety, and accuracy in the performance of maintenance actions.

The main objective of maintainability engineer is to design and develop equipment/system which can be maintained in the least time, at the least cost, and with minimum expenditure on the support resources such as, manpower utilisation, spare parts, tools and test equipment, services etc.

Maintainability is a part of engineering, which, was developed to provide design engineers with the source of specialised skills and knowledge in support of equipment/system maintenance functions. This was needed with the increased complexity, size and quantity of components in a system. It is one important element of design process which provides the designer with specialised information and data for consideration in the definition of equipment item or system.

In the planning stage, maintainability requirements are defined and translated into design criteria. Next the criteria are applied to design to establish the desired inherent functional and physical characteristics are then measured to verify quantitative and qualitative goals. And, finally, the design and the results of measurements are evaluated to assess areas of improvement. In this manner, the ultimate support requirements of the equipment/system are controlled to meet specific operational needs.

Maintainability is applicable to all type of equipment/systems. For commercial equipment it improves its sales. Therefore, today's competitive world, maintainability has a significant role to play to improve sales as well as market acceptability of the products. A formulated concept of maintainability, therefore, is the composite result of understanding specific, selected principles and how and why they are combined to attain certain detailed objectives.

Maintainability was developed over a period of time and went through many stages of progressive developments causing frequent changes in the meaning of word and redefinition of the area of work. Initially it was associated with design liaison, limited to review of drawings and equipment to assess inherent characteristics. Which was further extended to design services, system planning and system analysis. And today, maintainability is a distinct organisation in most companies and one that is fully integrated with all conventional line activities. At present the tasks performed by the maintainability organisations are extensive and exclusive.

Maintainability Terms

1. Maintenance—All actions required to bring an equipment/system in its working condition including repair, modification, overhaul, inspection and condition verification are the part of maintenance.
2. Maintenance-preventive—Maintenance performed to retain equipment/system to satisfactory condition by providing inspection, detection and prevention of incipient failures.
3. Maintenance-corrective—Maintenance performed to restore equipment/system to satisfactory condition after malfunction has caused degradation of system below the specified performance.
4. Mean-time-between-maintenance (MTBM) — It includes both preventive and corrective maintenance time.
5. Mean-time-between-replacement (MTBR) — It is the time for component replacements for preventive and corrective maintenance purposes. This will be required for procurement of spare parts.
6. Maintenance down time — That part of down time which is utilised for preventive/corrective maintenance functions.
7. Availability—It is defined as the probability that a system or equipment, when used under stated conditions, without consideration for any type of maintenance shall operate satisfactorily at a given point in time does not include time spent in maintenance and other such operations. It is of two types.
 - (i) Availability (achieved): It excludes logistic time and waiting and administrative time and includes preventive and corrective maintenance down time.
 - (ii) Availability (operational): It includes ready time, logistic time and waiting or administrative down time.

The above have been expressed by the equations given below.

It is directly related with the reliability of any system or equipment.

When equipment is put-up for use after manufacture and testing, it is said to be available and when it is under breakdown it is unavailable. The term availability can therefore be defined in terms of up time and mean down time of equipment/system.

$$A = \frac{UT}{UT + MDT} \quad \dots(3.1)$$

Where,

A → availability,

UT → machine/service time or up time

MDT → machine/system down time

Availability can be expressed in terms of mean time between failure and mean down time is given by

$$A = \frac{MTBF}{MTBF + MDT} \quad \dots(3.2)$$

The unavailability U is defined as the fraction of the total time test interval for which equipment is not performing to specification i.e., failed or down, therefore:

$$U = \frac{MDT}{MTBF + MDT} \quad \dots(3.3)$$

It is seen from above equations that availability can be improved by increasing $MTBF$ i.e., how fast equipment can be repaired and put back into service.

The equation (3.1) shows that availability calculations, it considers only two states of equipment/service viz., working or failed, whereas there will be spectrum of intermediate states as well. For practical purposes, idle (or ready) time of machine or product as well as the total time lost in administrative or operational delays cannot be overlooked. Thus, more explicitly, the equipment's working effectiveness is expressed in terms of its operational availability (OA) as given below:

$$OA = \frac{OT + IT}{OT + IT + AD + RT}$$

Where;

OT – operating time

IT – idle time

AD – administrative or operational delays

RT – repair time

Maintainability Analysis

The sequential development and review of data-concurrent with or preceding design development to aid in describing the optimum design characteristics of the equipment/system. The elements considered in review are (a) Quantitative requirements (b) Support resources (c) Cost (d) Operational objectives and (e) Safety. The results of review are translated into criteria which are applied to the design process.

Maintainability Engineering

An organisation which is associated with the maintenance functions of maintenance engineering, maintainability design, system analysis, design services, support documentation, system planning, safety engineering and system integration and test.

Mean Time to Failure (MTTF)

For reliability analysis it is important to know mean time to failure rather than the complete failure details. The parameter will be assumed to be the same for all the components which are identical in the design and operate under identical conditions. If we have life-tests information on a population of N items with failure times t_1, t_2, \dots, t_n then the $MTTF$ is defined as:

$$MTTF = \frac{1}{N} \sum_{i=1}^n t_i \quad \dots(3.4)$$

However, if a component is described by its reliability function and hazard model, then the *MTTF* is given by mathematical expression of the random variable *T* describing the time to failure of component. Therefore,

$$MTTF = E(T) = \int_0^{\infty} tf(t)dt \quad \dots(3.5)$$

$$f(t) = \frac{dF(t)}{dt} = -\frac{dR(t)}{dt}$$

Hence,

$$\begin{aligned} MTTF &= -\int_0^{\infty} tdR(t) \\ &= -tR(t)\Big|_0^{\infty} + \int_0^{\infty} R(t)dt \\ &= \int_0^{\infty} R(t)dt \end{aligned} \quad \dots(3.6)$$

The *MTTF* can also be computed by using Laplace-transform of *R(t)* i.e.,

$$MTTF = \int_0^{\infty} R(t)dt = \lim_{t \rightarrow \infty} \int_0^t R(x)dx$$

$$\text{However, } \lim_{t \rightarrow \infty} \int_0^t R(x)dx = \lim_{t \rightarrow \infty} R(s)$$

Where, *R(s)* is the Laplace-transform of *R(t)*

$$\text{Thus, } MTTF = \lim_{s \rightarrow 0} R(s) \quad \dots(3.7)$$

Example: A reliability test was carried out at 25 non-repairable Christmas tree light bulbs. The times at which failures occurred (in units of 10^3 hours) were as follows: 0.4, 0.9, 1.3, 1.7, 1.9, 2.4, 3.0, 3.3, 3.6, 4.1, 4.5, 5.0, 5.3, 5.6, 6.1, 6.4, 6.9, 7.1, 7.5, 7.9, 8.3, 8.6, 8.9, 9.5, 9.9.

- Use the data to estimate mean time to failure and mean failure rate.
- The reliability of the bulbs can be described by the equation:

$$R(t) = 1 - 10^{-4t}. \quad \text{Use the equation to estimate } MTTF \text{ and } \bar{\lambda}.$$

Solution:

$$\begin{aligned} MTTF &= \frac{1}{N} \sum t_i \\ &= \frac{1}{25} (0.4 + 0.9 + 1.3 + 1.7 + 1.9 + 2.4 + 3.0 + 3.3 + 3.6 + 4.1 \\ &\quad + 4.5 + 5.0 + 5.3 + 5.6 + 6.1 + 6.4 + 6.9 + 7.1 + 7.5 + 7.9 \\ &\quad + 8.3 + 8.6 + 8.9 + 9.5 + 9.9) \\ &= \frac{1}{25} (130.1) = 5.204 \end{aligned}$$

$$\begin{aligned}
MTTF &= 5.204 \\
R(t) &= 1 - 10^{-4t} \\
MTTF &= \int_0^{25} R(t) dt \\
&= \int_0^{25} (1 - 10^{-4t}) dt \\
&= \int_0^{25} 1 dt - \int_0^{25} 10^{-4t} dt \\
&= 25 - \int_0^{-100} \frac{10^x}{4} dx \\
&= 25 + \frac{1}{4} [10^x]_0^{-100} \log_e 10 \\
&= 25 + \frac{1}{4} [10^{-100} - 10^0] \log_e 10 \\
&= 25 + \frac{1}{4} [0 - 1] \log_e 10 \\
MTTF &= 24.425 \\
\bar{\lambda} &= \frac{1}{24.425} = 0.0409416
\end{aligned}$$

Mean Time to Repair (MTTR)

It is the mean time required for the maintenance purpose of a equipment/system. This time will directly depend upon the maintainability aspects of the system. In order to accurately determine the time item wise the maintainability engineer must budget the MTTR of the various equipment/system items such that the statistical mean is equal to or less than the over all system MTTR requirement. Budgeting is accomplished by means of maintainability allocation.

An allocation consists of determining the contribution of active down time of each equipment item, and the evaluation of the contributions for all such equipment items against the established MTTR requirement for the system.

For example, it is assumed that a system is required to meet an inherent availability requirement of 99.89 per cent and a reliability MTBF requirement of 450 hrs.

The MTTR equation is:

$$MTTR = \frac{MTBF(1 - A_i)}{A_i}$$

And by substituting the specified values

$$MTTR = \frac{450(1 - 0.9989)}{0.9989} = 0.5$$

Thus, the systems MTTR requirement is 0.5 hr.

The next step is to prepare function system diagram as drawn in Fig. 3.3. The objective is to allocate an MTTR quantitative value against each indented level of the equipment.

The Table 3.1 shows the allocation process of a system after having obtained relevant information from the reliability engineer.

Table 3.1 System Allocations

1. Item	2. Quantity per sys Q	3. Failure rate (1000 Hrs) λ	4. Contribution of total failures $Cf = Q\lambda$	5. % contribution of total failures $Cf/\Sigma Cf$	6. Av. main Corr. Hrs $Mct.Hr$	7. Contribution Total main Corr. time $Cm = Cf.McT$
1Unit A	1	1.71	1.71	0.76	0.5	0.855
2Unit B	1	0.48	0.48	0.21	0.4	0.192
3Unit C	1	0.06	0.06	0.03	0.8	0.048
Total			2.250	1.00		1.095

$$MTTR = Cm/Cf = 1.095/2.250 = 0.487 \text{ Hrs (Required is 0.5 Hrs)}$$

In the same manner allocation at each lower level i.e., equipment wise can be made and then finally entered in functional system diagram Fig. 3.1, which provides overall view of total system requirements.

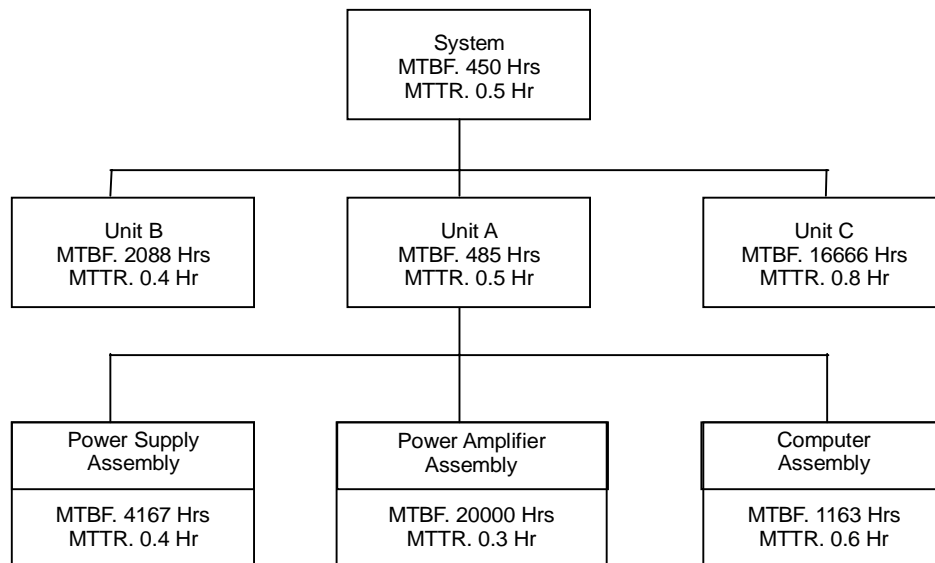

Fig. 3.1: Function System Diagram.

Maintainability Criteria

With the identification of the maintenance concept and maintenance functions, and the accomplishment of a maintainability allocation, it is possible to generate detailed design

criteria. Such criteria constitute specific maintainability goals in the areas of standardisation; interchangeability, degree of self test features, quantity and placement of test points, throwaway verses repair levels, modularisation, accessibility, cables and connectors, safety features, labeling etc. This criterion may be stated quantitatively or qualitatively and employed as guidelines for the design engineer. Qualitative criteria must support the quantitative goals derived through the maintainability allocation.

With regard to development of design criteria the above mentioned example can be cited. The allocated MTTR of a unit is 0.5 hr. This means in the event of malfunction the maintenance technician must be able to accomplish all related works in 30 min time. For electronic equipment the time spent on localisation and isolation of failure is about 60 per cent of total time. And it takes about 25 per cent time for disassembly and removal of faulty item, installation of operational item and reassembly. About 15 per cent time is spent on alignment and adjustment and testing. The above times are based on experience, corrective maintenance for the average maintenance cycle of the electronic equipment/system. Therefore, it should be borne in mind to check that the time is sufficient to carry out the maintenance function. This infers that the major assemblies must be directly assessable and must not require the removal of another assembly to gain access. In addition, the assembly should be plug-in and/or should be held to the base plate by not more than four quick release type fasteners.

Relative to assembly itself, the question of whether the item should be designed for discard-at failure or for repair is raised. By similarity with like items in the other already existing systems, the maintainability engineer can estimate anticipated support requirements. With this information in hand, a trade off study can be accomplished to determine the best approach for a discard-at failure verses repair trade off. If the decision is discarding, each assembly should be a module (sealed) and accessibility, internal test points etc. are not required. However, if the decision is repair, then specific maintainability design criteria should be established. With the information available as discussed above, the maintainability engineer will be in a position to derive initial criteria for all elements of the equipment using functional analysis and quantitative data for system development. Criteria should comply with the basic principles of the maintainability within the quantitative goals stated to assist the design engineer in producing equipment which will meet the customer's requirements. Maintainability design criteria may be modified to reflect additional needs.

Once design criteria have been defined, the maintainability engineer assumes the role of monitoring design progress against the specified design criteria. This monitoring process is accomplished through day-to-day design liaison activity, maintainability prediction tasks and periodic-design reviews.

MTTF and MTTR

The mean time to failure (MTTF) basically depends on the failure times of each component/items assembled in an equipment/system. When the reliability functions and hazard model of the component is known the MTTR can be expressed in the above terms. Whereas, mean time to repair (MTTR) depends upon inherent availability of the equipment/system, and on mean time between failures (MTBF) of components/items. This time will also depend upon maintainability aspects of the equipment. It has been pointed out in the maintainability allocation that how important is the repair time of a component for calculating the MTTR and all the aspects of maintenance such as, identification of faults, replacement, testing etc., should be taken care off.

Availability and Reliability

Availability of an equipment/system is of three types i.e., inherent, achieved and operational. The inherent availability is dependent on mean time between failures and mean time to repair. It excludes ready time, preventive maintenance down time, logistic time and waiting or administrative down time. On the other hand, achieved availability depends on mean time between maintenance and mean maintenance time. It excludes logistics time and waiting or administrative time and includes active preventive and corrective maintenance down time. The operational availability depends on mean time between maintenance, mean down time and ready time.

Reliability of a unit (or product) is the probability that the unit performs its intended functions adequately for a given period of time under the stated operating conditions or environment. Therefore, reliability definition stresses on four elements namely:

- Probability
- Intended functions
- Time and
- Operating conditions.

Reliability is a function of time and also depends on environmental conditions which may or may not be function of time. Its value is always between 1 and zero.

It is therefore, evident that directly or indirectly availability and reliability is inter related. If the availability of the equipment/system is high its reliability will be higher. However, quality of a device is also important parameter to improve the reliability of the component/item. But, one can build a reliable complex system using less reliable elements but it is impossible to construct a "good" quality system with "poor" quality elements. Because, the reliability of system can be improved by using extra units in parallel.

Availability and Maintainability

No equipment/system can be perfectly reliable inspite of the designer's best efforts and it is bound to fail during its operation which may be some times dangerous and costly in terms of safety. Maintenance therefore, becomes an important consideration in long-term performance of the equipment. The system requires preventive maintenance to eliminate the impending failures during its operation. Maintainability is a performance indices associated with such equipment/system on which maintenance is performed.

Maintainability can be defined as the probability that a failed equipment is restored to operable condition in a specified time (called down time) when the maintenance is performed under stated conditions. It characterises the adoptability of equipment to detection and elimination of failures as well as their prevention.

Frequency of failures measures reliability and how long it is down states the maintainability aspects. Both have close link with cost, complexity, weight and operational requirements. The more reliable and equipment and better its maintainability, the rarer it fails and shorter is its down time.

Availability is another measure of performance of maintained equipment. It integrates both reliability and maintainability parameters and depends on the number of failures that occur and how quickly any faults are rectified. This has been discussed in earlier chapters.

QUESTIONS

1. What are terms used to express maintainability?
2. Why is maintainability an important element of the design team?
3. What is the significant difference between MTTF and MTTR?
4. How availability is related with reliability? Explain.
5. Discuss the terms used in maintainability.
6. Explain how MTTF is related with reliability?
7. How a maintainability criterion helps in design?

**This page
intentionally left
blank**

Reliability Mathematics

INTRODUCTION

Reliability is directly related to probability and statistics, which also deals with uncertainty. In fact this is the case in much of modern engineering, and the probabilistic as opposed to the deterministic approach to engineering problems are becoming more widely applied. Failure of equipment/system is random phenomenon, so it can be defined in terms of probability. Further, it can be stated that, within specified statistical confidence limits, the probability of failure lies between certain values above and below this probability. If a sample of such equipment is tested, we can obtain data which are called statistics. The problems associated with reliability may be:

1. Finding the strength (or weakness) of a manufactured part
2. Estimation of life time of an equipment/system
3. Determination of number of failures
4. Determination of spare parts for a product
5. Determination of repair time and
6. Analysis of service utility of an equipment/system.

As it is known that reliability theory heavily leans on probability theory for its development and application.

The approach to the investigation of any reliability problem is fourfold.

1. Understanding of the physical problems associated with the real situations under consideration and with related areas of interest. (Construction of physical model)
2. Expression of physical model into mathematical terms.
3. Application of suitable techniques of mathematics to solve the model and
4. Translation of results of mathematical model into statement about real situation.

Boolean Algebra

An algebraic system consisting of a set B of elements a, b, c, \dots and two binary operations called sum and product, denoted respectively by $+$ and \cdot , is called a boolean algebra iff for all $a, b, c \in B$, the following axioms are satisfied.

- | | |
|---|------------------------|
| (1) $a + b, a \cdot b \in B$ | (Closure property) |
| (2) $a + b = b + a$ and $ab = ba$ | (Commutative property) |
| (3) $(a + b) + c = a + (b + c)$ and $(ab)c = a(bc)$ | (Associative property) |

$$(4) a \cdot (b + c) = ab + ac$$

$$\text{and } a + (b \cdot c) = (a + b) + (a + c) \quad (\text{Distributive law})$$

(5) An additive identity 0 and a multiplicative 1 (both belonging to B) exist such that

$$\forall a \in B, a + 0 = a \text{ and } a \cdot 1 = a \quad (\text{Identity})$$

(6) $\forall a \in B$ there exists an element $a' \in B$ such that

$$a + a' = 1 \text{ and } a \cdot a' = 0 \quad (\text{Complement or inverse})$$

Remark: The axioms, especially (6) is quite different from usual arithmetic or algebraic structures. First, the additive and multiplicative inverses of an element are usually different e.g., in real numbers, additive inverse of 2 is (-2) whereas multiplicative inverse of 2 is $1/2$. In boolean algebra, both inverses are the same. Secondly, in boolean algebra, the inverses are reversed, Usually we have $a + a' = 0$ and $a \cdot a' = 1$. In boolean algebra, we have $a + a' = 1$ and $a \cdot a' = 0$. This is more like sets, where $A \cup A' = \xi$ (Universal set) and $A \cap A' = \phi$ (null set). Observe that ξ acts as multiplicative identity, since $A \cap \xi = A$ and ϕ acts as additive identity (i.e., zero element) since $A \cup \phi = A$, $\forall A \subseteq \xi$. Also note that in boolean algebra, generally inverse of a is denoted as a' and not a^{-1} .

Since propositions and sets are classified example of boolean algebras, many texts use \vee and \wedge or \cup and \cap instead of $+$ and \cdot .

Modern computers use boolean algebra a lot – bits 0 and 1 correspond to electrical switch off or on, current absent or following, bulbs off or on, capacitor discharged or charged etc.

Example: Let $B = \{0, 1\}$ and let two operations $+$ and \cdot be defined on B as follows.

+	1	0
1	1	1
0	1	0

\cdot	1	0
1	1	0
0	0	0

Then B , or more precisely by triplet $(B, +, \cdot)$ is a boolean algebra.

Here 1 is multiplicative identity and 0 is the additive identity.

Let A be a family of sets which is closed under the operations of union, intersection and complement. Then (A, \cup, \cap) is a boolean algebra. Note that universal set ξ is the unit element and the null set ϕ is zero element.

Example: If $V = \{1, 2, 3\}$, $A = \{1, 2\}$, then $A' = \{3\}$. Show that the set of subsets $T = \{V, A, A', \phi\}$ along with operations \cup and \cap forms boolean algebra.

Solution: We have to show that this system satisfies basic axioms of boolean algebra (i.e., (1) to (6)).

- (1) Closure: Check that all unions and intersections of subsets V, A, A', ϕ belong to T
- (2) Operations \cup and \cap are commutative in sets
- (3) Operations \cup and \cap are associative in sets
- (4) Operations \cup and \cap are distributive in sets
(i.e., $A \cup (B \cap C) = (A \cup B) \cap (A \cup C)$ etc.)
- (5) Identity element for \cup , that is zero element (or additive identity) is ϕ , since $V \cup \phi = V$; $A \cup \phi = A$; $A' \cup \phi = A'$; $\phi \cup \phi = \phi$. Identity element for operation \cap (that is, unit element) is V since $V \cap V = V$; $A \cap V = A$; $A' \cap V = A'$; $\phi \cap V = \phi$

- (6) Inverse: Inverse of A is A' and inverse of V is ϕ (check) since all basic axioms are satisfied, the system (T, \cup, \cap) is boolean algebra.

Duality in a Boolean Algebra

By definition, the dual of any statement in a boolean algebra is the statement derived by interchanging $+$ and \cdot and also interchanging the identities 1 and 0 in the original statement.

For example, the dual statement $a + b = b + a$ is $a \cdot b = b \cdot a$ and dual of statement $a + a = 1$ is $a \cdot a = 0$.

The principal of duality says that the dual of any theorem in a boolean algebra is also theorem. (A theorem is derived from the basic axioms; dual statement of theorem can be proved by using dual of each step of the proof of original theorem. For example, if we can prove that $a + a = a$, it will follow that $a \cdot a = a$; if we can prove $a + 1 = 1$, it will follow that $a \cdot 0 = 0$)

Elementary Properties of Boolean Algebra

Important of these are:

- (i) (Idempotent law): $a + a = a$ and $a \cdot a = a$
- (ii) $a + 1 = 1$ and $a \cdot 0 = 0$
- (iii) (Involution law): $(a')' = a$
- (iv) $1' = 0$ and $0' = 1$
- (v) (De Morgan's law): $(a + b)' = a' \cdot b'$ and $(a \cdot b)' = a' + b'$
- (vi) (Law of absorption): $a + (a \cdot b) = a$ and $a \cdot (a + b) = a$
- (vii) (Uniqueness of inverse): $\forall a \in B, a'$ is unique.

Example 1: Prove that $ab + c(a' + b') = ab + c$.

Solution: $ab + c(a' + b') = ab + c(ab)'$ (de Morgan's law)
 $= (ab + c) \cdot (ab + (ab)')$ (Distributive law)
 $= (ab + c) \cdot 1$ (Definition of complement)
 $= ab + c$ (Identity).

Boolean Expressions and Functions

In Boolean algebra $B = (a, b, \dots, +, \cdot)$, the specific elements like 0 and 1 are called constants; variables like x , and y may denote any element of B ; x' and $x + y$ and $x \cdot y$ etc. are called monomials; $x' + xy$ etc. are called polynomials.

A boolean expression is any expression built from variables x, y, z, \dots etc. by applying the operations $+$ and \cdot a finite number of times. Examples of boolean expression are x' ; $x + y$; $(x + y) \cdot (x' + y')$ and $(x \cdot y)$.

A boolean function is determined by boolean algebra expression for example;

$$\begin{aligned} f(x) &= x' \\ f(x, y) &= x + y \\ g(x, y) &= x \cdot y \end{aligned}$$

Two different boolean expressions may represent the same boolean function. Exp. $x \cdot (y + z)$ and $(x \cdot y) + (x \cdot z)$ represent same boolean function.

Construction of Switching Circuits

A switch is a device which can be put in an electric circuit and it may assume either of two states:

(i) closed (on; True; T; 1) or (ii) open (off; false; F ; 0)

In closed state, it allows current to pass through and in open state, no current can pass through. A switch is indicated by symbol.

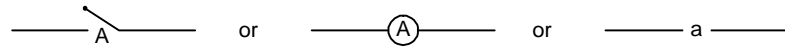

Where A is true allows current to pass through.

In a series combination of two switches, A and B , current can pass through only if both A and B are closed. This can be represented as $A \cap B$ or ab

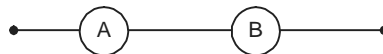

Note that if both a and b are true, then ab is true

In parallel combination of two switches, A and B , current can pass through if either A or B (or both) are closed. This can be represented as $A \cup B$ or $a + b$

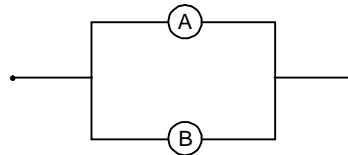

Note that if either of a or b is true then $a + b$ is true

Example 1: Describe boolean polynomial for the following circuits

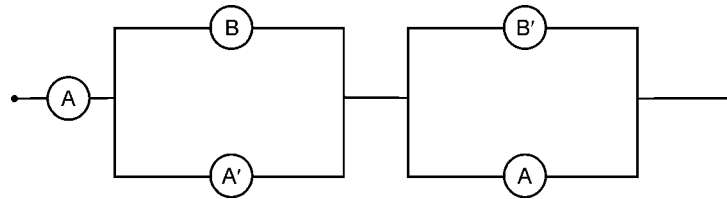

Solution: $A \cap (B \cup A') \cap (B' \cup A)$

Example 2:

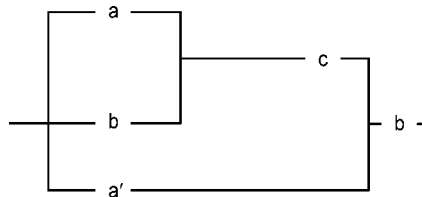

Solution: $(a + b)(c + a')b$

Simplification of Switching Circuits

If a given circuit is to be simplified, find the corresponding boolean expression, simplify the expression and construct a switching circuit for the simplified expression.

Example 3: Write the statement for the following switching circuit

$$\left[\begin{array}{c} a - b - c' \\ a - b' - c \\ a - b' - c' \end{array} \right]$$

Solution: Corresponding boolean expression is $abc' + ab'c + ab'c'$

It can be simplified as

$$\begin{aligned} abc' + ab'c + ab'c' &= abc' + ab'(c + c') \\ &= abc' + ab' = a(bc' + b') \\ &= a(b' + bc') = a(b' + b)(b' + c') \\ &= a(b' + c') = ab' + ac' \text{ or } a(b' + c') \end{aligned}$$

The simplified switching circuit is

$$-\left[\begin{array}{c} a - b' \\ a - c' \end{array} \right] \text{ or } -a \left[\begin{array}{c} b' \\ c' \end{array} \right]$$

Set Theory

Set is a collection or an aggregate of well defined object. These objects which belong to the set are called elements or the members of the set. Sets are normally denoted by capital letters A, B, C , etc. and their elements by small letters a, b, c , etc. 'Well defined' here means that any object may be classified as either belonging to the set A or not belonging to the set A .

Notations:

1. If a is an element of a set A , we write it as $a \in A$ and read it as "a belongs to A ".
2. $a \notin$ means that a is not an element of the set A and read it as a does not belong to the set A .

Representation of Set

1. A set can be represented by actually listing the elements which belong to it.

Example: If A be the set consisting of the number 2, 4, 6 and 8 then we write

$$A = \{2, 4, 6, 8\} \text{ (roaster method)}$$

2. Set builder form of a set

Some times a set is defined by stating property (rule) which characterises all the elements of the set. we write

$$A = \{x \mid P(x)\} \text{ or } A = \{x : P(x)\} \text{ and is read as}$$

A is the set of elements x such that x has the property P

Comparing Sets

When two sets have same number of elements, such a matching is called 'one-to-one correspondence', otherwise it will be unmatched sets.

Equality of Sets

Two sets A and B are said to be equal if every element of A is an element of B and also every element of B is an element of A i.e., both of them have the same elements, and are written as $A = B$.

Example: If $A = \{1, 2, 4\}$; $B = \{1, 4, 2, 2, 4, 1\}$ then $A = B$, since each element of A is in B and each element of B is in A . If sets are not equal then $A \neq B$.

Cardinal Number of a Set

The number of elements in the finite set A which is denoted by $n(A)$ is called the cardinal number of the set A .

If $A = \{2, 4, 6, 8, 10\}$, then $n(A) = 5$

For empty set A , $n(A) = 0$, for singleton $n(A) = 1$

Equivalent Sets

Two sets are said to be equivalent, if they contain the same number of elements i.e., If $n(A) = n(B)$, then sets A and B are equivalent.

Equal sets are equivalent but equivalent sets are not always equal.

FINITE AND INFINITE SETS

(i) Finite – Contains finite number of elements e.g.

$$A = \{a, e, i, o, u\}; n(A) = 5$$

(ii) Infinite – which is not finite e.g., set of all natural numbers.

EMPTY SET

Which contains no element at all is called the Empty set, Null set, or Void set and is denoted by ϕ .

Subset

If A and B are two sets such that every element of set A is also an element of B , then A is called a subset of B and represented as $A \subset B$. If A is not subset of B we write $A \not\subset B$

If A is a subset of B , then B is called super set of A and written as $B \supset A$.

Venn Diagram

All the sets are subset of a fixed set U called universe which is represented by rectangle. Each circle represents one subset of the universal set.

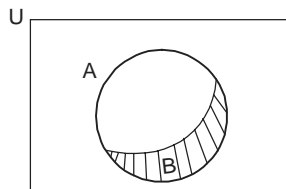

Example: If $A = \{\text{the prime factor of } 30\}$

$B = \{\text{the prime factor of } 70\}$

$C = \{\text{the prime factor of } 42\}$

List the elements of A , B and show their relationship in a Venn diagram.

Solution: The elements of the sets are

$A = \{2, 3, 5\}$

$B = \{2, 5, 7\}$

$C = \{2, 3, 7\}$

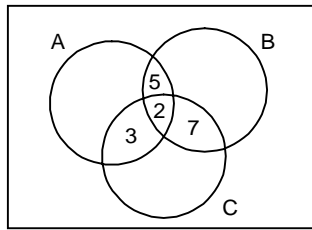

Family of Sets

A set whose elements are themselves sets, then the set formed is called the family of sets, or the class of sets or the sets of sets.

Example: If $A = \{a, b, c\}$

Then $\phi, \{a\}, \{b\}, \{c\}, \{a, b\}, \{a, c\}, \{b, c\}, \{a, b, c\}$ are elements of the set of all subsets of A .

The set $S = \{\phi, \{a\}, \{b\}, \{c\}, \{a, b\}, \{a, c\}, \{b, c\}, \{a, b, c\}\}$ is a family of sets.

Power Set

The family of all the subsets of a given set is called the power set. Power set of a set S is denoted by $P(S)$

Note (i) ϕ and S are both elements of $P(S)$

(ii) If $S = \phi$, then $P(\phi) = \{\phi\}$

(iii) If $S = \{a\}$, then $P(S) = \{\phi, \{a\}\}$

If a finite set S has n elements, then the power set of S has 2^n elements.

Difference of Sets

If A and B be two given sets, then set of all elements which belong to A but do not belong to B is called the difference of sets A and B and is denoted by $A - B$.

The set of all elements which belong to B but do not belong to A is called the difference of sets B and is denoted by $B - A$.

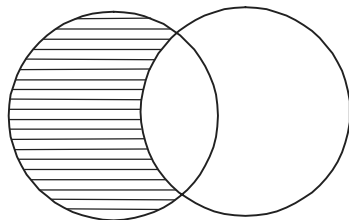

$A - B$

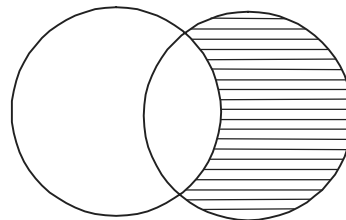

$B - A$

$$\therefore \begin{aligned} A - B &= \{x : x \in A, x \notin B\} \\ B - A &= \{x : x \in B, x \notin A\} \end{aligned}$$

$A - B$ is also termed as the complement of B with respect to A .

Note (i) $A - B$ is a subset of A . $B - A$ is a subset of B .

(ii) In general $A - B \neq B - A$.

Disjoint Sets

Two sets A and B are said to be disjoint or mutually exclusive if and only if there is no element common to A and B i.e., $A \cap B = \phi$.

Example:

Let

 $A = \text{Set of even natural numbers}$ $B = \text{Set of odd natural numbers}$

Here A and B are disjoint sets because they do not have common element. The disjoint sets are represented by two non-intersecting sets.

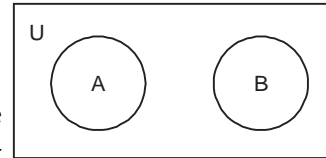
**Set Operations**

The system of operations on the sets are (i) Union of sets (ii) Intersection of sets.

Union of Sets

The union of sets A and B is the set consisting of elements which belong to A or B or to both and is written as $(A \cup B)$.

$$A \cup B = \{x : x \in A \text{ or } x \in B\}$$

The shaded area in the venn diagram represents $A \cup B$.

Example: $A = \{1, 2, 4, 5, 6\}$, $B = \{3, 5, 7, 9, 11, 12\}$.

$$A \cup B = \{1, 2, 3, 4, 5, 6, 7, 9, 11, 12\}.$$

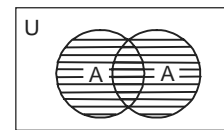
**Union of More than Two Sets**

If $A_1, A_2, A_3, \dots, A_n$ are the subsets of \cup and $n \in N$, then the set

$$A_1 \cup A_2 \cup A_3 \cup \dots \cup A_n = \bigcup_{i=1}^n A_i$$

consists of the numbers of \cup which belongs to at least one of the subsets A_i .

Example: If $A = \{1, 2, 3\}$, $B = \{3, 4, 5, 6\}$, $C = \{2, 5, 7, 8\}$, $D = \{1, 5, 9\}$

$$A \cup B \cup C \cup D = \{1, 2, 3, 4, 5, 6, 7, 8, 9\}$$

Intersection of Sets

The intersection of two sets A and B is the set consisting of elements which are common to A and B and is written as $A \cap B$.

$$A \cap B = \{x : x \in A \text{ and } x \in B\}$$

The shaded area represents $A \cap B$.

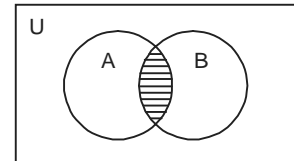
**Intersection of more than two sets**

The intersection of sets $A_1, A_2, A_3, \dots, A_n$ is represented by

$$A_1 \cap A_2 \cap A_3 \dots \cap A_n \text{ i.e., } \bigcap_{i=1}^n A_i$$

$$= \{x : x \in A_i \forall i's\}$$

Example: $A = \{a, b, c, d, e\}$, $B = \{b, d, e\}$, $C = \{d, e, f\}$, $D = \{b, d, f, g\}$

$$\therefore A \cap B \cap C \cap D = \{d\}.$$

Distributive Laws

I. If A, B, C are any three sets then

$$A \cup (B \cap C) = (A \cup B) \cap (A \cup C)$$

i.e., the union of sets distributes over the intersection of sets.

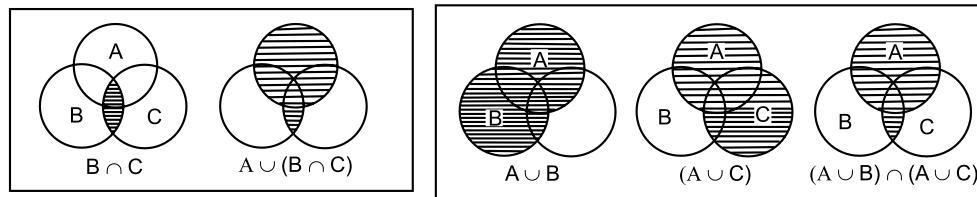

II. If A, B, C are any three sets then
 $A \cap (B \cup C) = (A \cap B) \cup (A \cap C)$
 i.e., the intersection of sets distributes over the union of sets

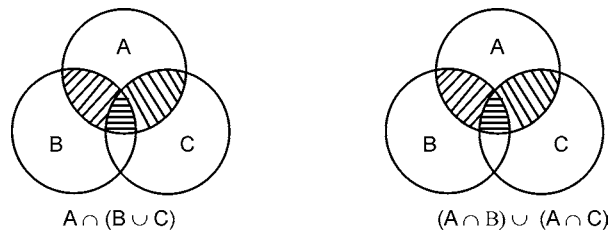

Complement of a Set

Let U be the universal set and A is a subset of U ,

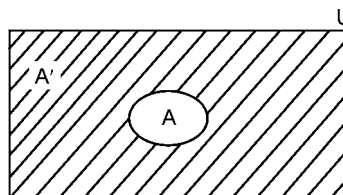

then the complement of A with respect to U , denoted A' , is defined as

$$A' = \{x : x \in U \text{ and } x \notin A\}.$$

i.e., complement of A is the set of those denotes elements of U which are not element of A .

Example:

- (i) If $U = \{1, 2, 3, 4, \dots\}$, $A = \{2, 4, 6, 8\}$
 Then $A' = \{1, 3, 5, 7, \dots\}$.
- (ii) If $U = \{x \mid x \text{ is a letter in English alphabet}\}$
 $B = \{a, e, i, o, u\}$ i.e., the set of vowels
 Then $B' = \{x \mid x \text{ is a consonent in English alphabet}\}$

De-Morgan's Law

- (i) $(A \cup B)' = A' \cap B'$
- (ii) $(A \cap B)' = A' \cup B'$

Sample Space

The construction of mathematical model and its verification requires experimental data (information) through suitable representation. Each such representation is called an element or point and the set of all possible elements is termed as sample space of the experiment. It is denoted by S . For example, when we test a bulb to find out whether it is good (1) or bad (0), the sample space consists of two sample points

$$S = [1, 0]$$

If we take two bulbs instead of one, then the S would contain four sample points.

$$S = [(1,1), (1, 0), (0, 1), (0, 0)]$$

There are three types of sample spaces for most applications

1. Finite sample space: A sample space containing only a finite number of outcomes. (or sample points).
2. Infinite sample space: A sample space containing denumerable infinity of sample points. A coin is tossed until head appears.
3. Non-countable or non-denumerable sample space: A sample space containing an interval of real numbers as possible outcomes. (Measuring the strength of rod)

Since, the sample points of the first two types are discrete, they are often called discrete sample spaces and the third type continuous sample space.

Event

It is the outcome of a trial which the part of experiment. A subset of a sample space is also called event.

When a dice with numbers on the faces from 1 to 6 is thrown, the sample space is

$$S = \{1, 2, 3, 4, 5, 6\}$$

Then $A = \{1, 3, 5\} = \{\text{getting an odd number}\}$, $B = \{2, 4, 6\}$

$C = \{1, 2, 3, 4\} = \{\text{getting less than 5}\}$, null set ϕ and S itself are some events.

Simple event is a single possible outcome of an experiment. For example, if 3 coins are tossed up, {HHH}, {HTH} etc. indicate simple events. A simple event is also called elementary event or indecomposable event.

Compound event is the joint occurrence of two or more simple events. e.g., {HHT, HTH, THH, HHH} is a compound event is also called decomposable event. {getting a number less than 5} is not a sure event. Sure event is the sample space itself. For example, when we throw dice, $S = \{1, 2, 3, 4, 5, 6\}$. Then getting number less than 7 is a sure event whereas {getting a number less than 5} is not a sure event.

Impossible event corresponds to null set ϕ . For example, in the case of dice. {getting a number higher than 6} is an impossible event.

Equally likely event. If there is no reason for any event to occur in preference to any other event, are equally likely. For example, in drawing a card from well shuffled pack, all 52 possible outcomes are equally likely.

Exhaustive event. The events E_1, E_2, \dots, E_n are called exhaustive if $E_1 \cup E_2 \cup \dots \cup E_n = S$. For example if $S = \{1, 2, 3, 4, 5, 6\}$, $A = \{1, 3, 5\}$, $B = \{2, 4, 6\}$, $C = \{1, 2, 3, 4\}$ then $A \cup B = S$,

So A and B are exhaustive events. But $A \cup C = \{1, 2, 3, 4, 5\} \neq S$,

So A and C are not exhaustive events.

Mutually exclusive events. If two events cannot occur simultaneously, then they are called mutually exclusive.

Mutually exclusive and exhaustive events.

Event E_1, E_2, \dots, E_n are called mutually exclusive and exhaustive if $E_1 \cup E_2 \cup \dots \cup E_n = S$

i.e., $\bigcup_{i=1}^n E_i = S$ and $E_i \cap E_j = \phi$ for all $i \neq j$.

Complement of event. The complement of an event E , denoted by \bar{E} or E' or E^c is the set of sample points of the space other than the points occurring in E .

In other words $E^c = S - E$

Note that $E \cup E^c = S$ and $E \cap E^c = \phi$.

RANDOM VARIABLE AND ITS DISTRIBUTION

A random variable is often described as a variable when values are determined by chance.

For example, let S be the sample space of a simultaneous throw of two coins. then $S = \{HH, HT, TH, TT\}$.

Let x denote the number of heads, then x can be 0, 1, 2, only.

Let y denote the number of tails, then y can be 0, 1, 2, only.

Both x and y are random variables (also called stochastic variables). We define random variable x as a real valued function x defined over the sample space of an experiment.

The set of values assumed by x is called range. In the above example, range of x is $\{0, 1, 2\}$.

Random variable is called discrete, if it assumes only finite or countable infinite number of values; for example, number of heads in n tosses of a coin.

Random variable is called continuous, if it can assume values in an interval.

Probability distribution of a random variable.

In the above example, we know that

$$p(x=0) = \frac{1}{4}, \quad p(x=1) = \frac{2}{4} = \frac{1}{2}, \quad p(x=2) = \frac{1}{4}$$

If a discrete random variable can assume values $x_1, x_2, x_3, \dots, x_n$ with respective probabilities p_1, p_2, \dots, p_n then we can say that $p(x)$ is probability distribution of x .

Note that $p(x) \geq 0$ for all $x = x_i$ and $\sum_{i=1}^n p(x_i) = 1$

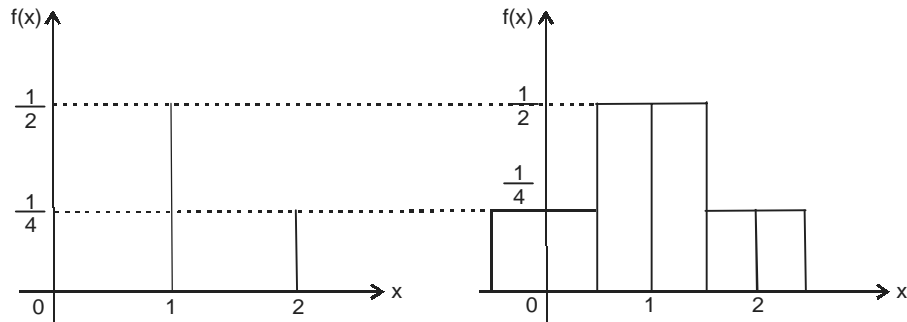

As another example let a dice be rolled twice, and a success be defined as getting a value 5 or 6. Then we may have 0, 1, or 2 success.

$$p(x=0) = \frac{4}{6} \cdot \frac{4}{6} = \frac{4}{9}$$

$$p(x=1) = \frac{4}{6} \cdot \frac{2}{6} + \frac{2}{6} \cdot \frac{4}{6} = \frac{4}{9}$$

$$p(x=2) = \frac{2}{6} \cdot \frac{2}{6} = \frac{1}{9}$$

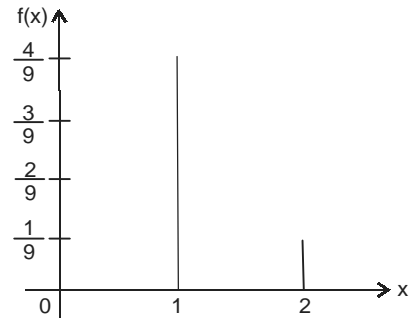

FAILURE DISTRIBUTION

The diversity of a random variable is extremely great. The number of assumed values may be, finite, countable, uncountable, the values may be distributed discretely or continuously. In order to specify the probabilities of the values of the random variables that are so diversified, and to be able to specify them in one and the same fashion, the concept of "distribution function" is introduced into the theory of probability.

During the reliability analysis of an equipment/system it is essential to know its failure pattern. In some cases, it is not possible to get actual information regarding failures of components and sub assemblies. In such cases it is desired to know the nature of the failure or in other words the failure distribution. The failure pattern can be obtained from field data, which are collected from the history cards of the equipment/system. In some cases, it is desired to identify the failure indicating parameters before actual failure of the equipment/system takes place, as the past information on the subject matter is not available. The methods employed for ascertaining such values are termed as hazard/failure functions and are of immense help for the calculation of reliability. This will also help to determine failure density functions and failure distributions. The cause of failures can be anything predictable or unpredictable. These can be represented graphically in the form of histogram or a frequency bar diagram.

RANDOM VARIABLES

All the events are initially associated with real numbers and later on with the probabilities. The outcome of an event may be an integer number such as 0, 1, 2, 3 and so on but event corresponding to each value is evident. The function, which assigns numbers to events, is called as random variable. This is neither random nor a variable in real sense. In the real world random variable is an ordinary variable which is selected randomly. In other words, once a random variable is well defined, we may speak of any value in the range of the random variable as if it were actually the event. It makes sense, thereby, to speak of the probability that a random variable, X , equals some particular number. It is important to note that, values of random variables have probabilities associated with them only because the values correspond to events, which deserve the probability directly.

The random variables are of two types, the first being discrete, where the variables are integers or more precisely, a countable subset of real numbers. Second one, being continuous, where the range consists of all values over an interval of the real numbers. By random variable we mean that each number of the sampled population should have an equal chance of being selected.

For example, to test the strength of material, standard test specimen that are machined from randomly selected bars are then tested. Their dimensions may vary though made by the trained technicians and therefore the test results, since the testing is done on a random specimen, the experiment is random experiment and outcome of the result is a random variable. These results can be expressed in many ways.

QUESTIONS

1. Explain how Boolean Algebra helps in the construction of switching circuits.
2. The probabilities of five non-mutually exclusive events occurring are: 0.01, 0.02, 0.04, 0.05, 0.08
 - (a) What is the maximum probability of any two events occurring simultaneously?
 - (b) What is maximum probability of any three events occurring simultaneously?
 - (c) Estimate the probability of any one of the five events occurring.
3. A bowl contains 50 capacitors out of which 10 are defective.
 - (a) What is the probability of drawing defective capacitors from the bowl?
 - (b) What is the probability of drawing two good capacitors from the bowl?
4. Let $S = \{1, 2, 3, 4, 5, 6\}$ represent the set of outcomes of the throw of a die. If $A = \{1, 3\}$, $B = \{2, 4\}$ and $C = \{3, 4, 5\}$ determine the following:
 - (a) $A \cap C$; (b) $A \cup (B \cap C)$; (c) $B \cup (A \cap C)$; (d) $C \cap (A \cup B)$; (e) $\overline{A \cap C}$
5. A semi conductor manufacturer wishes to test four different values of voltage at three different levels of vibrations. How many test runs are required?
6. A switching net work has three sections as shown in Figure Section A has four switches, B has three switches and C has two switches. In how many different ways can the connections be established between x and y .

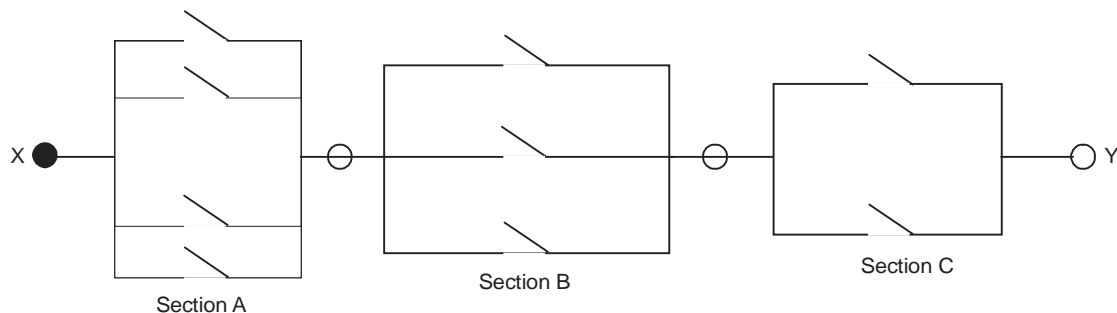

7. An electric circuit has 15 joints. Each of them is likely to be defective. In how many different ways may the circuit have just five defectives?

**This page
intentionally left
blank**

Probability and Distribution

INTRODUCTION

The use of statistics in reliability is very important, since it is associated with probability and other parameters, which are variables. The reliability assessment can only be made from field data or some laboratory experiments. The components/systems, which are either manufactured or fabricated may not have the same life. The performance of each component depends on many factors such as manufacturing defects, strength of the material used and other environmental conditions such as temperature, humidity etc. Since, reliability depends on the factor which are variable, a knowledge of statistical nature of variables is necessary. The data collected for the study and analysis will play a vital role, since the final results obtained will depend on them. The number of failures and the repair times of the equipment/system will be in the form of number or variable, therefore, knowledge about it, is essential. The facts expressed in quantitative form can be termed as data, which again is a variable. In this chapter, we will discuss some aspects of statistics related to reliability analysis.

CONCEPT OF PROBABILITY

Reliability is directly associated with probability, therefore its basic concept needs to be discussed at this point before discussing the various distribution involved in the study. Uncertainty is attached with human life. Decision-making in such areas is facilitated through formal and precise expressions for the uncertainties involved. Probability theory provides us with the ways and means to attain the formal and precise expressions for uncertainties involved under different situations.

Probability measures the uncertainty about the occurrence of a particular event or a set of events and is expressed numerically between zero and one. This can be estimated by any of the three methods given below:

- (i) Objective approach—which could be classical or empirical. These are based on natural laws or on the experiments performed actually and don't depend on individual opinions.
- (ii) Subjective approach—where probability measures the degree of confidence, which ultimately depends upon the occurrence and authenticity of the information used and plays important role in making decisions.
- (iii) Modern approach—which combines both the approaches cited above and are based on the theory of sets. This can be expressed through Venn diagram and Tree diagrams. The following terms are associated with probability.

Experiments

These are different than those carried out in physics or chemistry laboratories. Here, any action taken to specify the events is called experiment, which has three common parameters. The first being the outcomes of the experiments which may be two or more in number and secondly it is possible to specify outcomes in advance. The last item is that the outcomes are with certain uncertainty.

Sample Space

The set of all possible outcomes of an experiment is defined as the sample space. Each outcome is visualized as a sample point in the sample space. It is virtually, the field from where experiments are carried out, with certain outcomes.

Event

In probability theory, it constitutes one or more possible outcomes of an experiment. For example, tossing of coin i.e. head or tail. It can be defined as a sub-set of a sample space. Here event is used to refer to a single outcome or combination of outcomes.

The axioms of the probability are the following:

- (i) The probability of an even A , written as $P(a)$, must be a number between zero and one both values inclusive.
Thus,
$$0 \leq P(a) \leq 1.$$
- (ii) The probability of occurrence of one or the other all possible events is equal to one. As S denotes the sample space therefore, $P(s) = 1$.
- (iii) If two events are such that occurrence of one rules out occurrence of another, then the probability that either one or the other will occur is equal to the sum of their individual probabilities.

With above given axioms probability is defined as a function, which assigns probability value P to each sample point of an experiment abiding by the above axioms.

Probability Distributions

Any rule, which assigns probabilities to each of the possible values of random variable, is a probability distribution. For discrete random variables, the rule is to indicate the probability of each value separately. The function $p(x)$ is defined as:

$p(x) = P(X = x)$, and is called probability distribution function. It can also be expressed as cumulative distribution function $F(x)$ defined as:

$$F(x) = P(X \leq x).$$

It can also be expressed; in form of complementary cumulative function $G(x)$ which is expressed as

$$G(x) = P(X > x).$$

If any one of the above is known the others can be obtained.

For continuous random variable the situation is different because the range of possible values is infinite and is not consistent with axioms of the probability theory. Therefore, particular value to these random variable are difficult to assign.

Following are the commonly used distributions for failure/repair analysis of engineering systems. These distributions enable us to estimate parameters based on which statistical analysis of the equipment/system performance is computed and probabilistic/expected values found, concerning, mean time to failure, mean time to repair, availability and maintainability functions and reliability indices. Perhaps exponential and Weibull distribution are the most widely used distributions for life testing applications.

Conditional Probability

The probability of happening an event A such that the event B has happened, is called the conditional probability of A on the condition that the event B has already happened. It is denoted by $P(A/B)$. $P(A/B)$ means at what extent, the event B is contained in A , which is determined by the extent to which the events A and B are likely to occur simultaneously, i.e., $P(A \cap B)$. Thus $P(A/B)$ is proportional to $P(A \cap B)$

$$\begin{aligned} \text{i.e., } P(A/B) &\propto P(A \cap B) \\ \text{or } P(A/B) &= \lambda P(A \cap B) \end{aligned} \quad \dots(i)$$

$$\text{But } P(B/B) = 1$$

Replacing A by B in equation (i), we get

$$P(B/B) = \lambda P(B \cap B)$$

$$\text{or } 1 = \lambda P(B)$$

$$\text{or } \lambda = \frac{1}{P(B)}$$

Putting the value of λ in equation (i), we get

$$P(A/B) = \frac{P(A \cap B)}{P(B)} \quad \dots(ii)$$

If A and B are independent events, then

$$P(A/B) = P(A)$$

\therefore Equation (ii) is reduces to

$$P(A) = \frac{P(A \cap B)}{P(B)}$$

$$\text{or } P(A \cap B) = P(A) \cdot P(B)$$

\therefore the probability of happening of several independent event is equal to the product of their separate probabilities of happening.

NORMAL DISTRIBUTION

It is the most important continuous probability theoretical distribution and has been useful in countless applications involving every conceivable discipline. The theoretical distribution is an ideal representation of the real life behaviour of many mechanical components and systems. When the real behavioural patterns are represented in some mathematical forms, some common features can be extracted and these features display the similarities among diverse components and systems. A number of properties of this distribution make it easy and

useful for mathematical applications. The probability density function (*p d f*) for this distribution is defined by the equation given below:

$$f(x) = \frac{1}{\sigma\sqrt{2\pi}} e^{-[(x-\mu)^2/2\sigma^2]} \quad \dots(5.1)$$

$$-\infty \leq x \leq \infty$$

Where, μ is unrestricted parameter and σ is positive parameter and x is the real number denoting random variable.

Here variable μ and σ are the parameters to specify mean and standard deviation of a random variable. Any linear transformation of a randomly distributed random variable is also normally distributed.

The cumulative density function is expressed as:

$$F(X) = \int_{-\infty}^x \frac{1}{\sigma\sqrt{2\pi}} e^{-\frac{1}{2}\left(\frac{y-\mu}{\sigma}\right)^2} dy \quad \dots(5.2)$$

It is apparent from above that f is a positive function, $e^{-\frac{1}{2}\left(\frac{x-\mu}{\sigma}\right)^2}$ being positive for any real number x . It can be

shown that $\int_{-\infty}^{+\infty} f(x) dx = 1$, so that $f(x)$ is a valid p.d.f. The

plot of $f(x)$ and x gives a well spread curve symmetrical about the population mean μ and area under it is unity. For smaller values of σ the curves are peaked and for larger values of x the curve becomes broader. These are shown in Fig. 5.1.

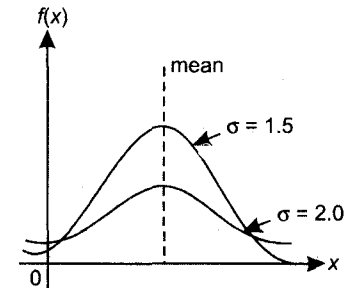

Fig. 5.1: Normal Distribution Curve

Every normal distribution with, whatever values of parameters can be represented in terms of the standard normal distribution which has a mean of zero and variance of 1. The linear transformation required to convert a normally distributed random variable X with mean μ and variance σ^2 to the standard normal random variable Z is

$$Z = \frac{X - \mu}{\sigma}$$

The density function of the standard normal random variable is just

$$f(x) = \frac{1}{\sqrt{2\pi}} e^{-\left(\frac{x^2}{2}\right)} \quad -\infty \leq x \leq \infty \quad \dots(5.3)$$

The normal distribution is reproductive that is the sum of the two or more normally distributed random variables is itself normally distributed. The mean of the sum, is always the sum of means. The variance of the sum is the sum of the variances provided that the random variables are independent. Even if they are not, the variance of sum can be expressed in terms of the variances and co-variances of the constituents.

The famous central limit theorem states, that the sum of the large number of independent arbitrary distributed random variable will be (approximately) normally distributed (under certain condition).

This distribution is not frequently used in reliability studies however, the failure density in wear out region in case of power system components is often represented by the normal distribution.

THE LOG NORMAL DISTRIBUTION

It is the distribution of a random variable whose natural logarithm follows a normal distribution. The log normal density function is expressed as:

$$f(x) = \frac{1}{\sigma x \sqrt{2\pi}} e^{[(\ln x - \mu)^2 / 2\sigma^2]} \quad \dots(5.4)$$

Where $x > 0$

The parameter μ and σ may given by:

$$\mu = E(\ln X)$$

$$\sigma = V(\ln X)$$

But the mean and variance of X are, respectively

$$E(X) = e^{\mu + (1/2)\sigma^2}$$

$$V(X) = e^{2\mu + \sigma^2}(e^{\sigma^2} - 1)$$

In practice, the best way to deal with a log normally distributed random variable X is to transform it by taking its natural logarithm. That is, let $Y = \ln X$, of course, Y would be normally distributed and is therefore easily handled.

The log normal distribution arises from the product of many independent non-negative random variables, as against in normal it is the sum of the independent random variables.

Under the following conditions the above distribution is useful.

- (i) The distribution is not symmetrical about the mean and
- (ii) The variables have only positive values.

The fact, why this distribution is used under above conditions is that while the random variable considered is by itself not normally distributed, its logarithm is normally distributed. The examples of these are compressive strength of concrete, fatigue life of mechanical components, and wear life of bearings, since random variables follow log normal distribution.

THE POISSON DISTRIBUTION

This distribution is more useful where number of trials or experiments is high and the probability of occurrence of an event is small. The Poisson distribution is the special case of Bernoulli's distribution. All that is required for the approximation is to give the distribution the same expectation. The general expression for this can be given as follows:

$$f(x) = \frac{\lambda^x e^{-\lambda}}{x!} \quad \text{Where } x = 0, 1, 2, 3, \dots, \infty \quad \dots(5.5)$$

X has a Poisson distribution with parameter λ , which must be positive. The important property of this distribution is that the expectation and variance are equal to each other.

$$E(x) = V(x) = \lambda$$

This distribution is productive, which means that the sum of Poisson distributed random variables will be another Poisson distribution.

Thus, the Poisson distribution represents the probability of an event occurring, a specified number of times in a given time interval or space when the rate of occurrence is fixed.

EXPONENTIAL DISTRIBUTION

For a continuous random variable the probability density function of exponential distribution can be expressed as:

$$f(x) = \lambda e^{-\lambda x} \quad x \geq 0, \lambda \geq 0 \quad \dots(5.6)$$

The cumulative distribution function has the following expression

$$F(x) = 1 - e^{-\lambda x} \quad \dots(5.7)$$

The complementary cumulative distribution function is expressed as:

$$G(x) = e^{-\lambda x} \quad \dots(5.8)$$

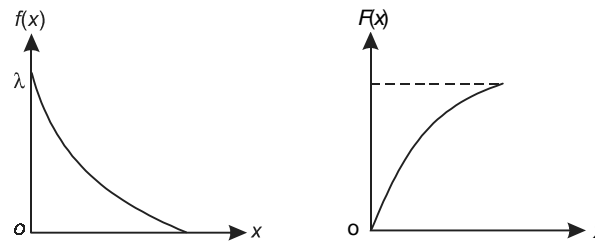

Fig. 5.2: Exponential Distributions

The expectation of negative exponential distributed random variable is $E(x) = \frac{1}{\lambda}$, which is reciprocal of the parameter and the variance is $V(x) = \frac{1}{\lambda^2}$.

The time between breakdown of machines and life of an electric bulb etc. are the some examples where the exponential distribution has been found useful. We may be interested in the random variable of the lapse of time before the first occurrence of event. Thus, for a machine, we note that the first failure may occur after a month or 1.5 months. The number of failures within a specified period is discrete and follows Poisson distribution, whereas the variable, time of first failure is continuous and will follow exponential distribution, since it represents uncertainty.

THE WEIBULL DISTRIBUTION

This is an important distribution used in the analysis of reliability of a equipment/system. By properly selecting the parameters the curve obtained can represent a variety of experimental/field results. It also represents a good approximation of normal distribution and also exponential distribution.

The Weibull distribution is of two types i.e., two parameters and three parameters and their corresponding density functions are given as below:

$$f(x) = \frac{m}{\theta} \left(\frac{x}{\theta}\right)^{m-1} e^{-\left(\frac{x}{\theta}\right)^m} \quad x \geq x_0 \quad \dots(5.9)$$

$$f(x) = \frac{m}{\theta - x_0} \left(\frac{x - x_0}{\theta - x_0}\right)^{m-1} e^{-\left(\frac{x - x_0}{\theta - x_0}\right)^m} \quad x \geq x_0 \quad \dots(5.10)$$

Where θ = characteristic or scale value ($\theta \geq 0$)

m = shape parameter

x_0 = guaranteed value of x ($x_0 \geq 0$)

If x_0 is equal to zero, the three parameter density function reduces to two parameter function.

The Fig. 5.3 shows the density function for different values of m . It is bounded by x_0 the lower tail and therefore, x_0 is called the guaranteed variate. The shape parameter controls the skewness of the distribution. When the values of x falls within the range $3.3 \leq m \leq 3.5$ the symmetry is displayed approximately with good fitness of normal distribution. When m equals to one it gives exponential distribution. The cumulative distribution function can be represented by the expression given below:

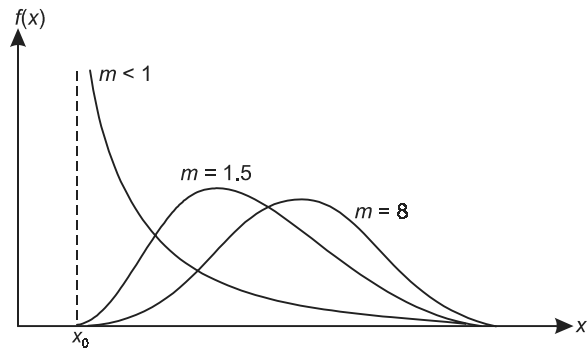

Fig. 5.3: Weibull Distributions

$$F(x) = e^{-\left(\frac{x - x_0}{\theta - x_0}\right)^m} \quad \dots(5.11)$$

But putting $x_0 = 0$ the cumulative distribution t is obtained for two parameters and expression will be

$$F(x) = 1 - e^{-\left(\frac{x}{\theta}\right)^m} \quad \dots(5.12)$$

The mean of the Weibull distributed random variable is

$$\mu_x = x_0 + (\theta - x_0) \Gamma\left(1 + \frac{1}{m}\right) \quad \dots(5.13)$$

and standard deviation is expressed as:

$$\hat{\sigma}_x = (\theta - x_0) \left[\Gamma\left(1 + \frac{2}{m}\right) - \Gamma^2\left(1 + \frac{1}{m}\right) \right]^{1/2} \quad \dots(5.14)$$

Where Γ is the gamma function?

The median of the distribution is expressed as:

$$X_{\text{med}} = x_0 + (\theta - x_0) (\ln 2)^{1/m} \quad \dots(5.15)$$

and mode is represented by,

$$X_{\text{mode}} = x_0 + (\theta - x_0) \left(\frac{m-1}{m}\right)^{1/m} \quad \dots(5.16)$$

This distribution has been useful for describing lifetime and waiting time in reliability applications. If in a system, there are many components, which have lifetime distribution of their own and if the equipment fails as any one of the component fails, then the lifetime of the equipment/system is minimum of the lifetimes of its components. Under these conditions, there is theoretical justification of expecting a Weibull distribution to provide close approximation to the lifetime distribution of the equipment/system.

THE GAMMA DISTRIBUTION

This is another important distribution used in reliability analysis particularly for failure of some electrical components. In a large, complex engineering system, if the shape factor of a number of failures takes place at a constant rate, then the failure of a system as a whole is distributed according to gamma distribution and can be expressed as:

$$f(x) = \frac{\lambda^n x^{n-1} e^{-\lambda x}}{\Gamma(n)} \quad \text{for } x, \lambda, n \geq 0 \quad \dots(5.17)$$

Where λ = scale factor
 n = shape factor and

$$\text{Gamma function } \Gamma(x) = \int_0^{\infty} x^{n-1} e^{-x} dx$$

Figure 5.4 shown the gamma density function for different value of λ and $n = 3$ when $n = 1$ the density function reduces to $f(x) = \lambda e^{-\lambda x}$ which is the exponential distribution.

For given value of the values of $\Gamma(n)$ can be found from the table. If n is an integer,

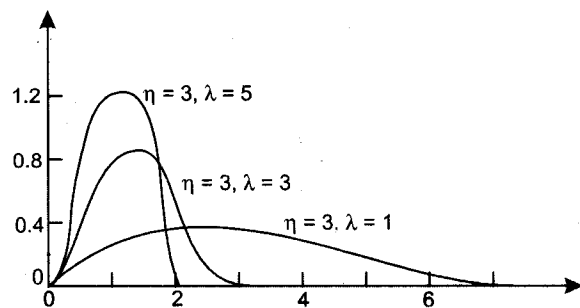

Fig. 5.4: Gamma Distribution

$\Gamma(\eta) = (\eta - 1)!$. In this case gamma distribution reduces to the Erlang. Therefore, gamma distribution is a special case of Erlang distribution. Under special conditions this distribution also represent Chi-square density function.

The expectation and variance of gamma distributed random variable X is expressed as:

$$E(X) = \frac{\eta}{\lambda}$$

$$V(X) = \frac{\eta}{\lambda^2}$$

THE BINOMIAL DISTRIBUTION

This distribution describes the situation where either of the two results i.e. success or failure are possible outcome of an experiment/trial. If K is the probability of success in each trail the failure probability is $r = 1 - k$. Such repeated independent trials are called Bernoulli trials, since there are only two possible outcomes for each trial/experiment. Their probability remains same throughout the trials/experiments. Then, the probability of success of x number of experiments out of n trials follows the binomial distribution law given by the following expression.

$$p(X = x) = C_x^n K^x r^{n-x} \quad \dots(5.18)$$

Where
$$C_x^n = \frac{n!}{x(n-x)!} \quad \dots(5.19)$$

From equation 5.18 the probability of no success is

$$p(X = 0) C_x^n K^0 r^n = r^n$$

and probability of at least one success is

$$p(x \geq 1) = p(x = 1) + p(x = 2) + p(x = 3) + \dots$$

since
$$p(x = 0) + p(x = 1) + p(x = 2) + \dots + p(x = n) = \sum_0^n C_x^n K^x r^{n-x} = 1$$

$$p(x \geq 1) = 1 - p(x = 0) = 1 - r^n$$

The ratio x/n is called as proportion and mean of the binomial distribution can be shown to be

$$\bar{X} = nK$$

Also, the standard deviation of binomial distribution is found to be

$$\hat{\sigma} = \sqrt{nk r}$$

It is seen that binomial distribution is characterized by two parameter namely n and k . For large values of n and small values of k the binomial distribution can be approximated to a normal distribution.

USES OF DISTRIBUTIONS

Data collected from either experiment or field trials have to be checked for their approximate distribution since data are random in nature. Sometimes it is difficult to collect sufficient data for accurate analysis, knowing the pattern or distribution the same can be generated to follow the family appropriately. Through Bernoulli trials the success or failure of an event can be examined and this can fit under binomial distribution. In case of the large number of independent random variables, the central limit theorem can suggest the normal distribution. On the other occasions; the choice of distribution is influenced by the need for particular mathematical properties. The negative exponential distribution in Markov process models are selected for reasons that have little to do with observed data.

To really know the nature of data a histogram is a first step in identifying an appropriate distribution. This will indicate the shape and later it has to be fixed with nearest P.D.F. once at least a distribution type is fixed, the next problem is to set value for the parameter that fix the distribution within the family. In certain cases it is easy, for example, in case of Poisson distribution. Parameter λ is estimated by sample mean μ and σ^2 in case of normal distribution by the sample means and sample variance respectively. Gamma and Weibull distributions require additional statistical work before proper estimation of formulae. The next step is to validate the model by checking the goodness of fit. For this, statistical tests such as Chi-square and Kolmogorov—Smirnov can be used for goodness of fit. The null-hypothesis assures that the candidate distribution is correct however. Care should be taken for the quantity of data, because the tests carried out, may not yield correct results, if database is small. Only the large quantity of data can give satisfactory results with the aid of hypothesis.

QUESTIONS

1. Highlight the importance of statistics in view of reliability evaluation.
2. Define random variable and state how they are generated for experimentation.
3. What is the significance of failure distributions in the context of reliability?
4. How probability is associated with reliability? Discuss briefly.
5. Discuss the distributions which can be used for reliability analysis.
6. Why normal distribution has wide applicability in mathematical applications?
7. Explain why Weibull distribution is more appropriate in the case of reliability evaluation.

Reliability Data Analysis

INTRODUCTION

As discussed in earlier chapters, the reliability was defined in terms of probability, purpose, stated time period and stated operating conditions. Since, the probability is a number between 0 and 1, reliability of a device is expressed quantitatively. The adequate performance of device /components needs amplification, and should be expressed quantitatively to make it clear with other similar devices/components. The third parameter on which reliability depend is time period. A device without maintenance or repairs may function satisfactorily for a period of time, and with maintenance, this may get extended. If maintenance involves repairs and replacement this may extend further. So, this must be clearly specified whether system has to work with or without repair and maintenance. Some of these factors may get specified under operating conditions. The last point is the operating conditions, which definitely affect the performance of the device, because environment or test conditions in laboratory will not be the same as the field conditions under which the device works. So, the performance specifications and the period of operation under prevailing conditions have to be carefully stated for the reliability factor associated with the equipment or the device.

One of the major objectives of engineering design is the assurance regarding the adequate performance of an equipment/system within the constraints specified. These, constraints may not be regarding economic factors, but also use of materials of desired properties manufacturing or production processes involved, environmental conditions, duration or time factors, human interactions etc. In other words, system is a complicated affair because of the many factors involved and the associated uncertainties. Consequently, risk is the part of this system when an equipment/system is to be designed to meet certain specified criteria, the problem can be posed as one involving the stated requirements (or demand) versus capacity of the system (or supply) to meet those requirements. What makes the problem more complicated is the lack of complete information regarding both the demand and the supply. In the language of probability, both these become random variables. If X = supply factor, and Y = demand factor, then the reliability of the system is the probability of the event ($X > Y$) throughout the life of the system. Whether, the an equipment involves simple in nature or a complicated system with number of components/items.

A system comprises of components and units interconnected in such a manner that all units and components work in harmony and coordination so that complete system perform the stipulated task satisfactorily. The complexity of the system depends upon the number of components and units it has, and also on the functioning of all attached items to produce the desired results. Human also acts as one of the major component of this system. Therefore, the

reliability of the system depends not only on the reliabilities of the associated components and units, but also on mutual interactive effects on the functioning of the several units involved. For example, consider a simple electrical circuit involving transformers, resistors and condensers. While these individual components may perform satisfactorily by themselves, as an integrated unit the heat generated by the transformer may adversely affect the performance characteristics of the resistors, condensers etc., and as a result, the system performance as a whole may not be as desired. Further, when human factors are involved, their role in assuring satisfactory performance of the system can be very critical. Many failures of large complex systems with disastrous consequences have been attributed to human factors/failures.

RELIABILITY FUNCTION

Reliability can also be defined as the probability of non-failure. If $F(t)$ is the failure probability, then $[1 - F(t)]$ gives the non-failure probability. Thus, the reliability of device for time $T = t$ (i.e., the device functions satisfactorily for $T \geq t$) is

$$R(t) = 1 - F(t) \quad (6.1)$$

$$= 1 - \int_0^t f(\tau) d\tau$$

$$= \int_0^{\infty} f(\tau) d\tau = F(\infty) = 1 \quad (6.2)$$

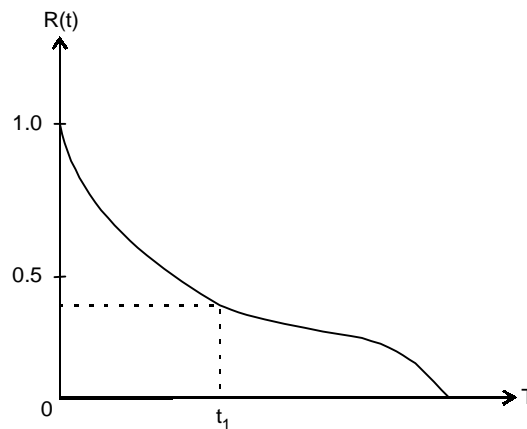

Figure 6.1

Above figure shows the shape of reliability function. Corresponding to reliability function $R(t)$, $F(t)$ is the unreliability function and represented by $Q(t)$.

The probability density $f(t)$ was defined as the derivative of the failure distribution function $F(t)$. Since $F(t) = 1 - R(t)$

$$f(t) = \frac{dF(t)}{dt} = -\frac{dR(t)}{dt} \quad (6.3)$$

The failure density is defined as the probability of failure occurring in a unit interval of time at time t . In other words, if Δn number of specimens failed in the time interval t and

$(t + \Delta t)$, the probability of failure during this interval is $\Delta n/N$. The probability of failure in a unit interval will then be

$$\text{Lt} \frac{1}{\Delta t} \left(\frac{\Delta n}{N} \right) \text{ as } \Delta t \rightarrow 0$$

But

$$\begin{aligned} \Delta n &= [\text{population at } t] - [\text{population at } (t + \Delta t)] \\ &= n(t) - n(t + \Delta t) \end{aligned}$$

Therefore,

$$\begin{aligned} f(t) &= \text{Lt} \frac{1}{\Delta t} \left(\frac{n(t) - n(t + \Delta t)}{N} \right) \text{ as } \Delta t \rightarrow 0 \\ &= \frac{1}{N} \frac{dn(t)}{dt} \end{aligned}$$

Instead of using the original population N , if we use the population $n(t)$ at time t , we get the instantaneous failure rate or the hazard rate $h(t)$, i.e.

$$h(t) = \text{Lt} \frac{1}{\Delta t} \left(\frac{n(t) - n(t + \Delta t)}{n(t)} \right) \text{ as } \Delta t \rightarrow 0$$

Dividing the numerator and denominator by N , we have

$$\begin{aligned} h(t) &= \text{Lt} \frac{1}{\Delta t} \left[\frac{\frac{n(t)}{N} - \frac{n(t + \Delta t)}{N}}{\frac{n(t)}{N}} \right] \\ &= \text{Lt} \frac{1}{\Delta t} \left[\frac{R(t) - R(t + \Delta t)}{R(t)} \right] \\ &= -\frac{1}{R(t)} \frac{dR(t)}{dt} \end{aligned} \quad (6.4)$$

The negative sign is because of the definition of a derivative. The concept of hazard rate is closely related to the idea of failure rate which is the rate at which failure occurs in a certain time interval (t_1, t_2) . This is defined as the probability that a failure per unit time occur in the interval (t_1, t_2) given that a failure has not occurred prior to the beginning of the interval t_1 . Mathematically, the interval failure rate (FR) is

$$FR(t_1, t_2) = \left(\frac{1}{t_2 - t_1} \right) \left[\frac{R(t_1) - R(t_2)}{R(t)} \right]$$

The hazard rate or the function is the failure rate when the time interval $(t_2 - t_1)$ approaches zero. Hence, sometimes it is called the instantaneous failure rate. Equation 6.4 can be written as

$$h(t) = -\frac{1}{R(t)} \frac{dR(t)}{dt} = -\frac{d}{dt} [\log n R(t)] \quad (6.5)$$

Also,

$$h(t) = -\frac{1}{R(t)} \frac{d}{dt} [1 - F(t)] = +\frac{1}{R(t)} \frac{dF(t)}{dt}$$

$$= + \frac{f(t)}{R(t)} \quad (6.6)$$

Here, $h(t)$ represents the probability that a device which has survived till time t will fail in the small interval t and $(t + \Delta t)$ (i.e. instantaneously as $\Delta t \rightarrow 0$). Thus, $h(t)$ is rate of change of the conditional probability of failure given survival till time t . On the other hand, $f(t)$ is the time rate change of the unconditional probability of failure. The importance of $h(t)$ is that it indicates the change in the failure rate over the lifetime of a population of devices. If $h(t)$ is increasing in $t > 0$, then $f(t)$ is said to increasing failure rate and vice versa.

BATH TUB CURVE

A typical graph portraying the hazard rate is the so-called bath tub curve. This curve will be different for two different conditions of whether component has repairable or non-repairable nature. The constant failure rate is for non-repairable items, whereas, repairable items the failure rate can vary with time. Repairable items can show decreasing failure rate (DFR) when reliability is improved by progressive repair, as defective parts which fail relatively early are replaced by good parts. There are three regions in a bath tub curve. The first region shows 'burn-in' period where number of failure are high. This is also called as infant mortality period. The second period is 'useful life' where, equipment failures are less, because of constant failure rates. The last region is 'wear out' where, failures are due wear and tear of the parts, and in this region also failures are high. For this region only the bath tub curve for mechanical equipment is different as compared to the electronic components/systems. An increasing failure (IFR) occurs in repairable systems when wear out failure modes of parts begin to predominate. This can be shown in figure given below.

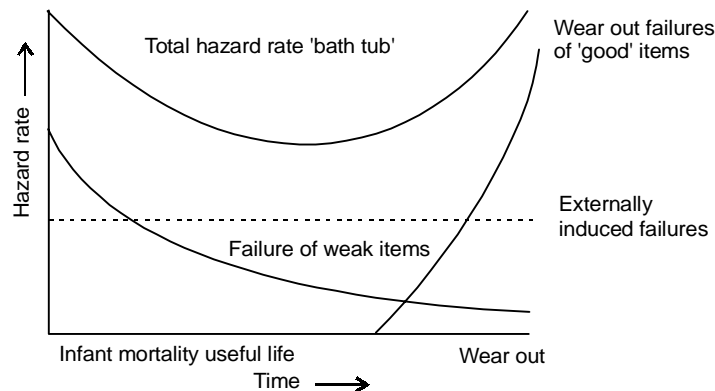

Fig. 6.2: Bath Tub Curve

DATA COLLECTION

Almost all equipment/systems are made up of parts and components. The failure of a part or component may lead to the failure of the whole system in some cases and may not in others depending upon the functional relationship of components. In any case each component contributes to the system reliability (or unreliability) and it is worth while to express system

reliability in terms of component reliability. This necessitates a careful analysis of functions of all components and their failure models.

Component failure models can be obtained in two ways (1) from the basic failure rates and working stresses using stress models, and (2) from part-failure data obtained either from life-tests or failure reports of customers. It is almost impossible to establish failure rates of components for all working conditions. However, it is possible through extrapolation or interpolation to predict reliability under specific stress conditions from the available data.

Normally an organization would establish a process designed to collect field data, which can be obtained from the 'log books' of the equipment/system. These log books record the history of the component/item from the day of its installation. All failures and repairs are recorded as and when the same are carried out. The MTBF will be determined by dividing the total cumulative operation hours for all fielded products by the number of failure occurrences.

In the design and development of new product, the design and reliability engineers, may not have available field data (reliability performance data), due to simple fact that the system has not been fielded. In this case reliability engineer must use alternative methods to determine the reliability of the proposed system.

Example: An Airfield Radar, the basic system will consist of a, Transmitter, Receiver, Antenna Assembly and Data Processing equipment and possible data communications equipment. From these functional groups of equipment we can estimate that there will be power suppliers, Digital circuit card assemblies, motors and servos etc. With this we can start the preliminary process of estimating the systems MTBF.

For preliminary estimation the MTBF may be determined by similarity, in other words, the MTBF of a known system (previously developed and fielded) is available, and therefore, this data will be used until more information becomes available to the users. Important to most people is the numeric performance value for an equipment or system, whatever, the numeric value, what is important is how it is derived for the equipment or systems.

Treatment of Field data

The table below shows the status report of a set of 1000 components which are put to operation simultaneously.

Table 6.1

Operating time(h)	0	100	200	300	400	500	600	700	800	900	1000
Number of surviving components	1000	895	810	730	660	600	545	495	450	410	373

The hazard rates and density functions are estimated using the following equations.

$$h(t) = \frac{n(t) - n(t + \Delta t)}{n(t)\Delta t} = \frac{\text{Failures in } \Delta t}{n(t)\Delta t}$$

$$f(t) = \frac{n(t) - n(t + \Delta t)}{N\Delta t} = \frac{\text{Failures in } \Delta t}{N\Delta t}$$

where, $n(t)$ = the surviving components, at beginning of the time interval Δt

$n(t+\Delta t)$ = the components surviving at the end of the time interval Δt

$N = n(0)$

Hazard rates and denoting functions are computed at various intervals are tabulated in Table 6.2.

Table 6.2

Time Interval Δt	$n(t)$	$n(t+\Delta t)$	Number of failures in Δt	$h(t) \times 10^{-2}$	$f(t) (\times 10^{-2})$
0 — 100	1000	895	105	0.105	0.105
101 — 200	895	810	85	0.095	0.085
201 — 300	810	730	80	0.099	0.080
301 — 400	730	660	70	0.096	0.070
401 — 500	660	600	60	0.091	0.060
501 — 600	600	545	55	0.092	0.055
601 — 700	545	495	50	0.092	0.050
701 — 800	495	450	45	0.091	0.045
801 — 900	450	410	40	0.089	0.040
901 — 1000	410	373	37	0.090	0.037

Data Storage and Recovery

Reliability analysis and assessment depends on the data collected after the equipment or system has been deployed. The failures of such systems should be recorded in due time and be stored properly, so that the same may be recovered as and when required. In olden times, there was a practice to maintain the 'Log book' equipment wise, where, all relevant information can be recorded and stored. Today's large scale equipment/systems have computerised recording system to store the information. In this case, also all failure statistics can be stored and can be made available to the designers or reliability engineers. But for small components/devices this facility can not be provided due to cost factors. Therefore, attempt should be made to record all the failure/repairs whenever, the same has occurred in any of the system.

The information provided by the suppliers of the system should not be taken at face value. Since, some of the suppliers must have made certain assumptions. In deriving their actual reliability they may have factored in a duty cycle with respect to total number of hours that the equipment (on average) is used or powered up. If one was to use this data as is, not knowing this fact, and decide to apply an operating duty cycle for their own intended environment, then a clear case of double dipping has occurred.

The ramification of not fully understanding how field data was derived could have a profound impact on the conclusion of a system/equipment reliability performance assessment which would directly influence spare parts, holding warranty and life cycle cost. It is therefore, evident that authentic information/data can only yield correct prediction about the reliability and due care should be exercised to collect field data properly and store them to establish the quality of data needs. Was the data collected and obtained in a realistic way, or were some data elements, obtained by making assumptions?

Component Reliability

The following expressions show how reliability function can be derived when the number of identical components is tested. Their success of survival and failures are estimated over well-defined time period. Here we consider a case where fixed number of identical items is

tested. The number of such items is N_0 . The test initiates at time $t = 0$. After an interval of time when $t > 0$, let us assume that:

$N_s(t)$ = Number of items survival at time t and

$N_f(t)$ = Number of items which have failed in time interval $(0 - t)$

At time t , the reliability $R(t)$ is given by:

$$\begin{aligned} R(t) &= \frac{N_s(t)}{N_0} \\ &= \frac{N_0 - N_f(t)}{N_0} \\ &= 1 - \frac{N_f(t)}{N_0} \end{aligned} \quad \dots(6.7)$$

Thus
$$\frac{dR(t)}{dt} = \frac{1}{N_0} \frac{dN_f(t)}{dt}$$

As
$$dt \rightarrow 0$$

$\frac{1}{N_0} \frac{dN_f(t)}{dt}$ is the instantaneous failure density function which is expressed by $f(t)$, and

$$f(t) = \frac{dR(t)}{dt} \quad \dots(6.8)$$

Since, the instantaneous hazard rate, $\lambda(t)$ is defined as the percentage of those remaining equipment that will fail in the next interval of time and is given by

$$\begin{aligned} \lambda(t) &= \frac{\frac{d}{dt} N_f(t)}{N_s(t)} \\ &= \frac{N_0}{N_0} \cdot \frac{1}{N_s(t)} \cdot \frac{dN_f(t)}{dt} = \frac{f(t)}{R(t)} \\ &= \frac{-dR(t)}{R(t) dt} \end{aligned} \quad \dots(6.9)$$

From equation (6.8)

$$-dR(t) = f(t) dt$$

or
$$\int_1^{R(t)} -dR(t) = \int_0^t f(t) dt$$

or
$$1 - R(t) = \int_0^t f(t) dt$$

= failure probability function $F(t)$

From equation (6.9)

$$-\frac{dR(t)}{R(t)} = \lambda(t)dt$$

or

$$\int_0^{R(t)} \frac{dR(t)}{R(t)} = -\int_0^t \lambda(t) dt$$

or

$$\log R(t) = -\int_0^t \lambda(t) dt$$

or

$$R(t) = e^{-\int_0^t \lambda(t) dt} \quad \dots(6.10)$$

The above equation shows that reliability and hazard/failure rates are the function of time.

From studies it is revealed that many components (electrical/electronics) have standard failure rate.

TIME DEPENDENT HAZARD MODELS

- (i) The hazard rate of a component can be found from the failure data by using the formula for various time interval.

$$h(t) = \frac{N_s(t) - N_s(t + \Delta t)}{N_s(t)\Delta t} \quad \dots(6.11)$$

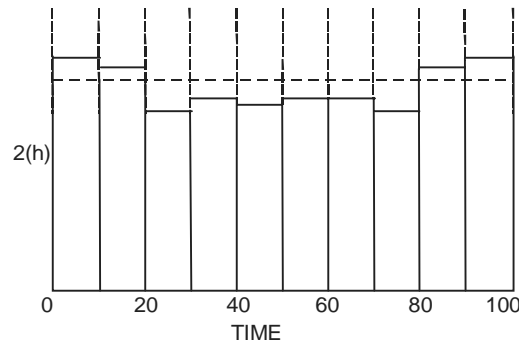

Fig. 6.3 Hazard-Rate Curve

The piecewise hazard rate function will approach the continuous hazard rate function when data become large and the time interval approaches zero. Such failure curves can be used to predict the failure rate of other similar components operating in similar conditions

- (ii) Constant-Hazard Model

The constant hazard model takes the form

$$h(t) = \lambda \quad \dots(6.12)$$

where, λ is constant and is independent of time, which is mostly used for electronic equipment/systems.

An item with constant hazard rate will have the following reliability and associated functions.

$$f(t) = \lambda e^{-\lambda t} \quad \dots(6.13)$$

$$R(t) = e^{-\lambda t} \quad \dots(6.14)$$

$$F(t) = 1 - e^{-\lambda t} \quad \dots(6.15)$$

$$\text{MTTF} = \int_0^{\infty} e^{-\lambda t} dt = \frac{1}{\lambda} \quad \dots(6.16)$$

(iii) Linear-Hazard Model

When components fail due to wear out or deterioration, hazard rate of such items increases with time and this model has the form.

$$h(t) = bt \quad t > 0 \quad \dots(6.17)$$

where, b is constant

$$R(t) = \exp \left[-\int_0^{\infty} bt dt \right] \quad \dots(6.18)$$

$$= \exp (-bt^2/2)$$

$$f(t) = bt \exp (-bt^2/2) \quad \dots(6.19)$$

It may be noted that $f(t)$ is a Rayleigh-density function. In the bath tub curve, the portion beyond the useful period might follow this model for some cases.

The mean time to failure is given by

$$\begin{aligned} \text{MTTF} &= \int_0^{\infty} e^{-bt^2/2} dt \\ &= \frac{\Gamma \frac{1}{2}}{2\sqrt{b/2}} = \sqrt{\frac{\pi}{2b}} \end{aligned} \quad \dots(6.20)$$

(iv) Non-linear-Hazard Model

It is observed that the hazard rate is not always linear i.e. increasing with time, therefore, more general form of hazard model is:

$$h(t) = at^b \quad \dots(6.21)$$

where a and b are constants.

this gives us

$$R(t) = \exp [-at^{b+1}/b+1] \quad \dots(6.22)$$

$$f(t) = at^b \exp [-at^{b+1}/b+1] \quad \dots(6.23)$$

This general form is known as weibull model and generates a wide range of curves for various sets of a and b . This model include above both models when $b = 0$ it is constant-hazard model and $b = 1$ represents linearly increasing - hazard model.

The parameter a affects the amplitude and b the shape of $h(t)$ and therefore, they are scale and shape parameters.

for this model

$$\text{MTTF} = \frac{\Gamma\left(\frac{1}{b+1}\right)}{(b+1)\left[\frac{a}{b+1}\right]^{1/(b+1)}} \quad \dots(6.24)$$

$$= \frac{d\Gamma(d)}{(ad)^d} \quad \text{where } d = \frac{1}{b+1} \quad \dots(6.25)$$

Gamma two parameter model is also applied in reliability work

(v) Other Models

These models do not fit in with previously discussed models but are used to describe the failure curves. The shifted model of the form.

$$h(t) = a (t - t_0)^b, \quad t > t_0 \quad \dots(6.26)$$

is used if initial hazard rate is nearly zero for sometime. This model is known as the three-parameter weibull model.

A model that roughly combines the constant and linear model is necessary to describe a failure curve that is initially constant and then increases. The following model can serve this purpose to a limited extent.

$$h(t) = ae^{ct} \quad \dots(6.27)$$

where a and c are constants

For this

$$R(t) = \exp [-(a/c)(e^{ct}-1)] \quad \dots(6.28)$$

Which is also known as the exponential-hazard model.

QUESTIONS

1. Explain the need of reliability data analysis.
2. Explain the application of hazard rate to reliability in case of repairable systems.
3. Derive expression for reliability function.
4. Illustrate the importance of data collection and treatment of field data.
5. A component with constant failure rate λ has already operated for a period of T hr. Prove that the probability of failure of the component during a further period of t hr is

$$Q = \exp(-\lambda T) (1 - \exp(-\lambda t))$$
6. A TV set is specified as having failure rate of 0.02 y. per 1000 hr. What does this mean to the user?
7. A total of 50 components whose MTTF is known to be 200 hr are placed on test continuously. Estimate the number of components which would fail in the time intervals 0 to 50, 50 to 100, 100 to 150 and 150 to 200.

Reliability of Systems

INTRODUCTION

In chapter-1 the relationship of reliability with failure probability, failure rate, mean time between failures etc. have been discussed. Most of the engineering systems are made up of several simpler components/elements. Their failure in due course of time is inevitable for various reasons such as wear, stress concentration or even breakage etc. As the systems are made up of components and units, the performance of these has to be integrated and coordinated so as to make the system work satisfactorily for a specified time period. The greater the number of elements involved larger is the system and its complexity, which will make the reliability analysis difficult. The reliability of the complete system will depend upon the reliability of the each element/component involved. This chapter deals with calculation of reliability for all complex systems presently used in industrial organizations. The models used for analysis of reliability are briefly discussed as under.

SERIES RELIABILITY MODEL

When the success of a system depends on the success of all its elements/components, this gives rise to a series reliability model. Consider the reliability block diagram of Fig. 7.1 in which n components with reliabilities as $R_1, R_2, R_3, \dots, R_n$ is connected in series. In some cases, the physical connection of the elements/equipment may not be in series but, if failure of one component brings the system to halt, is also a case of series system. The practical example of this is the connection of batteries in series for more power. However, the cylinders placed in internal combustion engines may have series configuration but the failure of one cylinder will not make the engine completely out of order though its performance will be reduced.

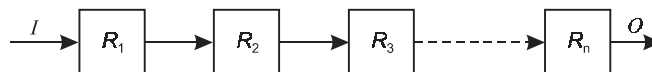

Fig. 7.1: Series Reliability Model

The system reliability R_{sys} is therefore the product of the individual reliabilities, i.e.

$$R_{\text{sys}} = R_1 \cdot R_2 \cdot \dots \cdot R_n \quad \dots(7.1)$$

If we assume further that each component can be described by a constant failure rate λ and if λ_i is the failure rate of i th component, then reliability of i th component, R_i can be expressed by

$$R_i = e^{-\lambda_i t} \quad \dots(7.2)$$

Thus, $R_{\text{sys}} = e^{-\lambda_1 t} \cdot e^{-\lambda_2 t} \dots e^{-\lambda_n t} \quad \dots(7.3)$

So that, if γ_{sys} is the total system failure rate then:

$$R_{\text{sys}} = e^{-\lambda_{\text{sys}} t} = e^{-(\lambda_1 + \lambda_2 + \dots + \lambda_n) t} \quad \dots(7.4)$$

and

$$\lambda_{\text{sys}} = \lambda_1 + \lambda_2 + \dots + \lambda_n$$

This means that the overall failure rate for a series system is the sum of the individual element or component failure rates. It is seen from above equations that if the number of components is minimum, the system reliability will be maximum.

The reliability can also be expressed in terms of unreliability and if $F_1, F_2 \dots F_n$ are the unreliabilities of the elements 1 to n and the system unreliability be F_{sys} . Then system reliability will be;

$$R_s = 1 - F_{\text{sys}} \quad \dots(7.5)$$

or

$$1 - F_{\text{sys}} = (1 - F_1) (1 - F_2) \dots (1 - F_n)$$

The unreliability of a series system with small values of unreliabilities can be given by:

$$F_{\text{sys}} = [F_1 \cdot F_2 \dots F_n] \quad \dots(7.6)$$

Series reliability models can be developed by using various distributions such as normal, exponential, uniform and other distribution functions to yield realistic results for mechanical systems/equipment.

Series Reliability-Components in Triplicate

Consider a system with identical components connected as shown in Fig. 7.1(a).

$$R = [(1 - R_1) (1 - R_2) (1 - R_3)]; 1 - (1 - R_1)^3$$

where $R_1 = R_2 = R_3$

$$= 1 - (1 - 3R_1 - 3R_1^2 - R_1^3)$$

$$= 3R_1 - 3R_1^2 - R_1^3$$

$$= 3e^{-\lambda_1} - 3e^{-2\lambda_1} + e^{-3\lambda_1}$$

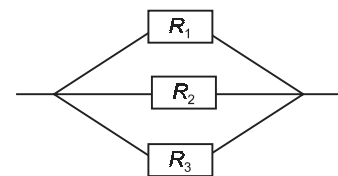

Fig. 7.1(a): Components in Triplicate

PARALLEL RELIABILITY MODEL

When a system of n components can function even if only one of the components is good, this gives rise to a parallel reliability model (fully redundant) [the example being multi cylinder engine]. Consider the block diagram vehicle of Fig. 7.2 in which elements (components having reliability as $R_1, R_2 \dots R_n$ are connected in parallel). The product law of unreliabilities derives the reliability of this system more conveniently.

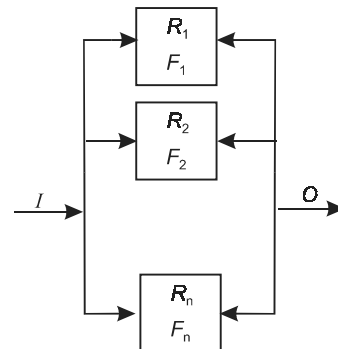

Fig. 7.2: Parallel Reliability Model

$$R_{\text{sys}} = 1 - \prod_{i=1}^n (1 - R_i) = 1 - \prod_{i=1}^n (1 - e^{-\lambda_i t}) \quad \dots(7.7)$$

The reliability can also be expressed as given below:

Consider that there are n individual elements/components connected in parallel with individual unreliabilities F_1, F_2, \dots, F_n respectively. All of the elements/components are expected to be working normally i.e. to be active and each one is capable of meeting the functional requirements placed on the overall system. The overall system will only fail when all of its elements/components fail. If one element or component survives the system survives. The overall system unreliability F_{sys} is therefore the product of the individual element/component unreliability i.e.

$$F_{\text{sys}} = F_1 \cdot F_2 \cdot F_n \quad \dots(7.8)$$

Comparing the equations 7.1 and 7.8 it is seen that for series system, the system reliability is the product of element/component reliabilities, whereas for parallel systems, unreliability is the product of element/component unreliabilities. If the individual elements/components are identical, so that $F_1 = F_2 = \dots = F_n = F$. This gives

$$F_{\text{sys}} = F^n$$

Thus, if $F = 0.1$ and there are four channels in parallel we have $F_{\text{sys}} = 10^{-4}$. It is seen that by increasing the number of elements/components in parallel system, increases the overall system reliability.

For example, consider a system with four elements whose failure-free performance probabilities are:

$$p(x_1) = 0.90, p(x_2) = 0.91; p(x_3) = 0.94 \quad \text{and} \quad p(x_4) = 0.92$$

Therefore, the system reliability is given by

$$\begin{aligned} R(s) &= 1 - [1 - 0.90] \cdot [1 - 0.91] \cdot [1 - 0.94] \cdot [1 - 0.92] \\ &= 1[0.1 \times 0.09 \times 0.06 \times 0.08] = 0.9999568 \end{aligned}$$

In case of r out of n system can be handled using the Binomial distribution. The general equation of redundant elements assumes that the elements are stochastically independent. Success of exactly r out of n identical independent components is given by,

$$\begin{aligned} R_S(r/n) &= {}^n C_r R^r (1 - R)^{n-r} \\ &= {}^n C_r e^{-r\lambda t} (1 - e^{-\lambda t})^{n-r} \end{aligned} \quad \dots(7.9)$$

and the success of at least r out of n elements is given by

$$\begin{aligned} R_S(r \text{ and more}/n) &= \sum_{k=r}^n {}^n C_k R^k (1 - R)^{n-k} \\ &= \sum_{k=r}^n {}^n C_k e^{-k\lambda t} (1 - e^{-\lambda t})^{n-k} \end{aligned} \quad \dots(7.10)$$

SERIES PARALLEL RELIABILITY MODEL

The parallel element model shown in Fig. 7.2 is also sometimes referred as active redundant system. Here active redundancy means that all elements are active and not kept in reserve. The case where elements are kept under reserve will be dealt with separately. The Fig. 7.3 shows elements in series and in parallel also.

It is a very common model being used in any engineering equipment where n identical sub-systems are placed in parallel and each system consists of m elements/components in series. If R_{ji} is the reliability of the i th element in j th subsystem then reliability of the j th subsystem is:

$$R_j = R_{j1} R_{j2} \dots\dots\dots R_{ji} \dots\dots\dots R_{jm} = \prod_{i=1}^{i=m} R_{ji} \quad \dots(7.11)$$

The corresponding unreliability of the j th subsystem is :

$$F_j = 1 - \prod_{i=1}^{i=m} R_{ji} \quad \dots(7.12)$$

The overall unreliability of the system is expressed by the following equation.

$$F_{\text{overall}} = \prod_{j=1}^{i=n} \left[1 - \prod_{i=1}^{i=m} R_{ji} \right] \quad \dots(7.13)$$

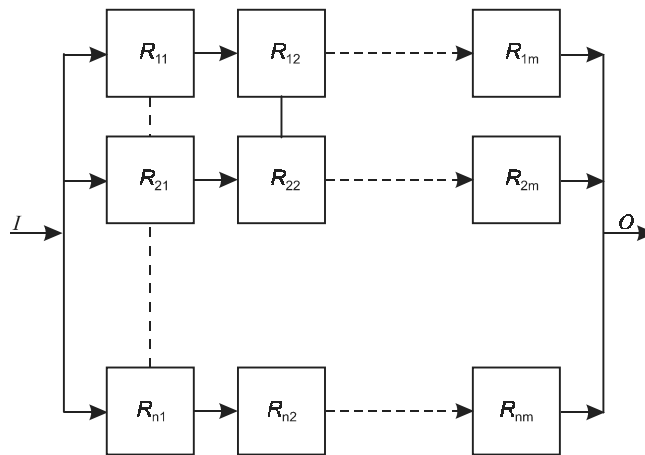

Fig. 7.3: Series Parallel Reliability Model

In the usual practice of obtaining the reliability expression for a series parallel system, the sub-system with parallel elements are individually reduced to single-element units by applying the rule of probability. Then, the system is modified to one consisting of equivalent elements, all connected in series and the final solution can be obtained using series reliability model.

DECOMPOSED RELIABILITY MODEL

In practice a complex system configuration is such that neither a pure series nor a pure parallel reliability model is appropriate. In this case the reliability structure of the complex system is decomposed into simpler sub-structure through successive application of conditional probability theorem. The technique starts with the selection of a key component/element which appears to bind together the overall reliability structure, and the reliability may be expressed in terms of the key component as:

$$R_s = P(\text{system success if } B \text{ is good}) \cdot P(Bx) + P(\text{system success if } B \text{ is bad}) \cdot P(By) \dots(7.14)$$

Where, $P(Bx)$ and $P(By)$ are respective success and failure/probabilities of the key component B . In equation (7.14) one difficult problem is decomposed into two easier ones. In a complex problem the decomposition process is repeated on the sub-structures formed after first decomposition and the system reliability is obtained sequentially. If a poor choice is made for the key component, the method still works well; but the derivation of reliability becomes cumbersome.

REDUNDANT RELIABILITY MODEL

In many complex equipment/system it is difficult to improve the reliability, by just selecting the good quality components only. In many cases it is desired to have a redundant and back up elements and subsystem to improve or enhance the reliability of the total system. Sometime safety aspects and hazardous conditions demand the use of redundant components or sub-systems. Automobiles carrying spare wheel are the example of such systems.

There are three types of redundancies that are applied to the system. Which include:

- (i) Active redundancy, where all the elements/component used are active. This also called as hot redundancy.
- (ii) Stand by redundancy, in this case duplicate or spare elements/systems are used in case of failure of main or the active components. Places where working on equipment/system are risky the concept of stand by is always employed. This may also be termed as cold redundancy.
- (iii) Light duty redundancies—this system is employed where the variations in load are experienced. Under such conditions spare or duplicate equipments/systems are kept under operation during light load conditions but can also be used when the active system fails. This is also called as worm redundancy. In the power generation area it is the most common practice to meet out the fluctuating loads.

Active Redundancy

Under this system all the redundant element components function along with the main ones and the system will only fail after all its elements/components have failed. Fig. 7.4(a) and (b) show two parallel systems where each element has been duplicated and connected with the main system.

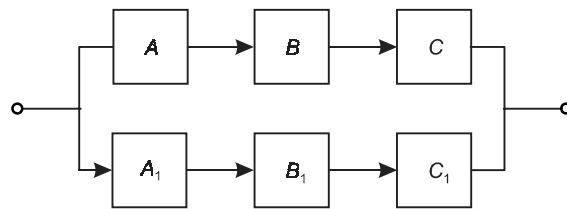

Fig. 7.4(a)

Let $p(A)$, $p(B)$, be the probabilities of failure free performance of the components and $R(s)$ is the probability of failure free performance of the system then from Fig. 7.4(a).

$$\begin{aligned}
 R(s) &= p(A \text{ and } B \text{ and } C) \text{ or } p(A_1 \text{ and } B_1 \text{ and } C_1) \\
 &= p(A) \cdot p(B) \cdot p(C) \text{ or } p(A_1) \cdot p(B_1) \cdot p(C_1) \\
 &= P_a P_b P_c + P_{a1} P_{b1} P_{c1} - P_a P_b P_c P_{a1} P_{b1} P_{c1} \\
 &= p^3 + p^3 - p^6 = p^3(2 - p^3) \text{ for identical components} \quad \dots(7.15)
 \end{aligned}$$

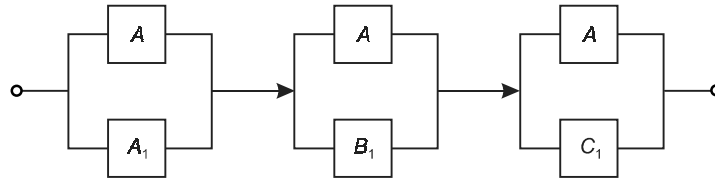

Fig. 7.4(b)

Similarly, for Fig. 7.4(b)

$$R(s) = p(A \text{ or } A_1) \text{ and } p(B \text{ or } B_1) \text{ and } p(C \text{ or } C_1)$$

Again considering identical components.

$$= (p + p - p^2)^3 = p^3(2 - p)^3 \quad \dots(7.16)$$

Assuming the value of $p = 0.9$

$$R(s) = 0.729 \quad \text{for Fig. 7.4(a)}$$

$$R_1(s) = 0.970 \quad \text{for Fig. 7.4(b)}$$

Stand by Redundancy

Two components A and B are connected in parallel Fig. 7.4(c) and both components are active. The reliability of failure free performance is expressed as

$$R(s) = p(A) \text{ or } p(B) \quad \dots(7.17)$$

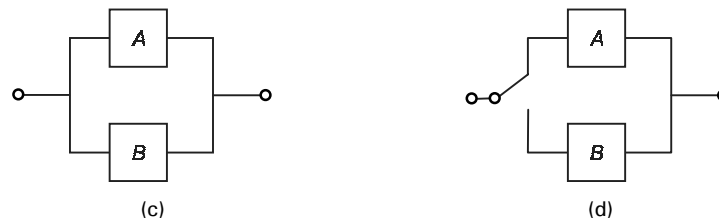

Fig. 7.4(c and d)

In Fig. 7.4(d) the component A is only active and the component B is kept under reserve and activated by a decision switch only when A fails. The switch used is considered reliable and operates instantaneously. The system can work under the following conditions.

- (i) Component A does not fail within the specified time t or
- (ii) Component A fails at time $(t_1 \leq t)$ and the component B operates without failure from time t_1 to time t .

The probability that component A does not fail with the given time t is expressed as:

$$R_1(t) = 1 - F_a(t) = \int_a^{\infty} f_a(\tau) d\tau \quad \dots(7.18)$$

Where, $f_a(\tau)$ is the failure density function for A . The probability that the component A fails in the interval $(t_1 \pm \Delta t_1/2)$ is $f_a(t_1)\Delta t_1$ the probability that the component B functions failure free from time t_1 to time t is given by the expression:

$$\int_{t-t_1}^{\infty} f_b(\tau) d\tau \quad \dots(7.19)$$

Where $f_b(\tau)$ is the failure density function of the component B . Therefore, the probability for both above conditions can be given as:

$$f_a(t_1)dt_1 \int_{t-t_1}^{\infty} f_b(\tau) d\tau$$

Since, t_1 and vary from 0 to t the probability for case (ii) then becomes.

$$R_1(t) = \int_0^t f_a(t_1) \left[\int_{t-t_1}^{\infty} f_b(\tau) d\tau \right] dt_1 \quad \dots(7.20)$$

Since, case (i) and (ii) are mutually exclusive the total probability is

$$\begin{aligned} R(t) &= R_1(t) + R_2(t) \\ &= \int_t^{\infty} f_a(\tau) d\tau + \int_0^t f_a(t_1) \left[\int_{t-t_1}^{\infty} f_b(\tau) d\tau \right] dt_1 \end{aligned} \quad \dots(7.21)$$

In the similar way the probability calculations can be done when more than one stand by components are considered.

MARKOV RELIABILITY MODEL

The reliability problem normally deals with systems that are discrete in nature and continuous in time in order to formulate a Markov model first defines all the mutually exclusive state of the system. For example, in a system of a single non-repairable element, there are two possible states, UP state when the element is operable and DOWN state when the element has failed. The states of the system at $t = 0$ are called initial states, and those representative of a final or equilibrium state are called the final state. The state space diagrams for this system are shown in Fig. 7.5.

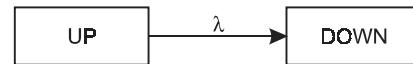

Fig. 7.5: State Space Diagram of Non-repairable Unit

The equations, which describe the probabilistic transitions from the initial to the final states, are known as Markov state equations. The transition probabilities follow two assumptions:

- (i) The probability of transition in time Δt from one state to another is given by $\lambda(t) \Delta t$, where $\lambda(t)$ is the hazard associated with the two states. If all the $\lambda_i(t)^S$ are constant, the model is known as homogenous. If any hazards are time functions, the model becomes non-homogenous.
- (ii) The probabilities of two or more transitions in time Δt are considered negligible.

Assume:

$P_0(t)$ = Probability that the component is being in UP state at time (t) ,

$P_1(t)$ = Probability that the component is being in Down state; and

λ = Failure/hazard rate.

Then, the probability that the component is in the UP state at time $t + \Delta t$, $P_0(t + \Delta t)$ is given by the product of the probability of the system in being UP state at time t , $P_0(t)$ and probability of no failure in time Δt , $1 - \lambda\Delta t$, plus the probability of being in DOWN state at time t , $P_1(t)$, times the probability of transition to the UP state (with repair) in time Δt . Thus,

$$P_0(t + \Delta t) = (1 - \lambda\Delta t) \cdot P_0(t) + 1.0P_1(t) \quad \dots(7.22)$$

And probability of being in DOWN state at $t + \Delta t$ is given by

$$P_1(t + \Delta t) = 1 \cdot P_1(t) + \lambda\Delta t \cdot P_0(t) \quad \dots(7.23)$$

The equations (7.22) and (7.23) can be summarized by writing the transitional probability matrix for the above system as given in Table 7.1.

Table 7.1: State Transition Matrixes

	0	1
0	$1 - \lambda\Delta t$	$\lambda\Delta t$
1	0	1

It may be noted that in a transition matrix its rows sum must be unity. Rearranging equations (7.22) and (7.23) gives:

$$\frac{P_0(t + \Delta t) - P_0(t)}{\Delta t} = -\lambda P_0(t)$$

$$\frac{P_1(t + \Delta t) - P_1(t)}{\Delta t} = \lambda P_1(t)$$

and

$$\frac{P_0(t + \Delta t) - P_0(t)}{\Delta t} \downarrow_{\Delta t \rightarrow 0} = P_0^l(t)$$

$$\frac{P_1(t + \Delta t) - P_1(t)}{\Delta t} \downarrow_{\Delta t \rightarrow 0} = P_1^l(t)$$

Therefore, in matrix form, it can be represented as:

$$\begin{bmatrix} P_0'(t) \\ P_1'(t) \end{bmatrix} = [P_0(t) \quad P_1(t)] \cdot \begin{bmatrix} -\lambda & \lambda \\ 0 & 0 \end{bmatrix} \quad \dots(7.24)$$

Assuming that the process starts in state 0 (i.e. at $t = 0$ the system is in UP state) such that $P_0(0) = 1$ and $P_1(0) = 0$; the solution for $P_0(t)$ and $P_1(t)$ may be obtained as below:

$$P_0(t) = e^{-\lambda t} \quad \dots(7.25)$$

$$P_1(t) = 1 - e^{-\lambda t} \quad \dots(7.26)$$

Equations (7.25) and (7.26) are considered as the reliability and unreliability expressions of a single element system (non-repairable). However, it must be noted that such a system or element is characterized by an exponential failure density function.

THE REPAIR/MAINTENANCE CONSIDERATION

The concept of repair/maintenance is associated normally with many equipments/systems. For repair/maintenance money is involved though the amount is a fraction of the money spent during the purchase of the equipment/system. Here, equipment considered is repairable. Markov models have the capability of dealing with repairable equipment/system provided that the failure and repair follow exponential distributions. In case of single repairable system the state diagram is as shown in Fig. 7.6.

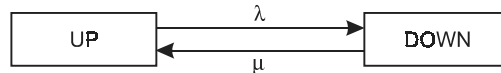

Fig. 7.6: State Space Diagram of a Repairable System

In this case, the differential equation of the system are shown in the matrix form as:

$$\begin{bmatrix} P_0'(t) \\ P_1'(t) \end{bmatrix} = [P_0(t) \quad P_1(t)] \cdot \begin{bmatrix} -\lambda & \lambda \\ \mu & -\mu \end{bmatrix} \quad \dots(7.27)$$

Where μ is the unit repair rate expressed in repairs per year?

Assuming the initial conditions as:

$$P_0(0) = 1.0 \quad \text{and} \quad P_1(0) = 0.0$$

The solution for $P_0(t)$ and $P_1(t)$ are:

$$P_0(t) = \frac{\mu}{\lambda + \mu} + \frac{\lambda e^{-(\lambda + \mu)t}}{\lambda + \mu} \quad \dots(7.28)$$

$$P_1(t) = \frac{\lambda}{\lambda + \mu} + \frac{\lambda e^{-(\lambda + \mu)t}}{\lambda + \mu} \quad \dots(7.29)$$

When t is sufficiently large, the equations (7.28) and (7.29) reduce to those shown below where the probabilities of residing in the UP or DOWN states have been designated respectively as the availability (A) and unavailability (U).

$$A = \frac{\mu}{\lambda + \mu} \quad \dots(7.30)$$

$$U = \frac{\lambda}{\lambda + \mu} \quad \dots(7.31)$$

The limiting values ($t \rightarrow \infty$) are independent of which state the system starts in. The failure and repair process is shown in Fig. 7.7. The value m and r are often referred to as the mean time to failure (MTTF) and mean time to repair (MTTR) respectively. The mean cycle time T ($T = m + r$) for this process is mean time between failure (MTBF). The reciprocal of T is designated as the cycle frequency, f . For a single repairable component having failure and repair rates (λ and μ) characterized by exponential distributions, result in.

$$\text{MTTF} = m = \int_0^{\infty} R(t) dt = \int_0^{\infty} e^{-\lambda t} dt = \frac{1}{\lambda} \quad \dots(7.32)$$

$$\text{MTTR} = r = \int_0^{\infty} M(t) dt = \int_0^{\infty} e^{-\mu t} dt = \frac{1}{\mu} \quad \dots(7.33)$$

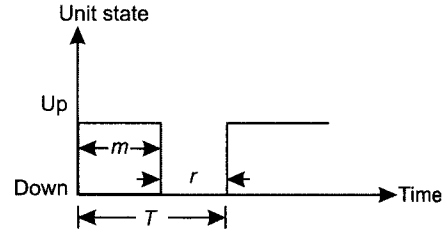

Fig. 7.7: Average Failure and Repair Cycle

In equation (7.33), $M(t)$ is the maintainability function, which is a measure of the reparability, defined as the probability that a system in a failed state will be restored to its operational state within a specified time period (t) when maintenance is initiated subject to stated conditions.

Likewise the single element system as discussed above, more complex system structure can also be handled using the Markov model. The complexity of Markov model depends on the number of system states. In general, a system comprising of n distinct elements will have 2^n states, whereas system with n identical elements will have only n states. This means that an n -element system may at the most need a solution of 2^n first order differential equations. Markov model has the advantage that it can be well extended to system having dependence, repair and stand by operation. However, for large number of equations use of computers can be made.

RELIABILITY INDICES

The use of reliability indices correlates the equipment/system performance with respect to time when reliability concept is being used. In order to appreciate the basic reliability indices, the equations (7.30) and (7.31) are to be examined for unit availability and unavailability as follows:

$$A = \frac{\mu}{\lambda + \mu} = \frac{1/r}{\frac{1}{m} + \frac{1}{r}} = \frac{m}{m+r} = \frac{m}{T} = \frac{f}{\lambda} \quad \dots(7.34)$$

$$U = \frac{\lambda}{\lambda + \mu} = \frac{1/m}{\frac{1}{m} + \frac{1}{r}} = \frac{r}{m+r} = \frac{r}{T} = \frac{f}{\mu} \quad \dots(7.35)$$

It can be seen from above equations that the frequency of encountering either of the two (UP or DOWN) states in the long run is given by:

$$f = \lambda A = \mu U \quad \dots(7.36)$$

In general, the frequency of encountering any given state is given by the product of the probability of being in that state and the rate of departure from it.

In a good repairable system (where $\lambda r \ll 1$) equations (7.34) and (7.35) can be approximated as:

$$A = \frac{\mu}{\lambda + \mu} = \frac{1/r}{\lambda + 1/r} = \frac{1}{\lambda r + 1} \approx 1.0 \quad \dots(7.37)$$

$$U = \frac{\lambda}{\lambda + \mu} = \frac{\lambda}{\lambda + 1/r} = \frac{\lambda r}{\lambda r + 1} \approx r \quad \dots(7.38)$$

Thus, the three basic reliability indices are λ and r and λr . If λ is the system average outage rate expressed in failure per year and r is the system average outage duration expressed in hours, the product λr is the system average total outage time expressed in hours per year. Interestingly, these indices very well answer the questions, how often and how long, and how many hours per year will the system be interrupted.

System Under Repair Mode

A system consisting of two components in series with outage rates, and repair times r_1 and r_2 respectively has:

$$\text{System outage rate; } \lambda_s = \lambda_1 + \lambda_2 \quad \dots(7.39)$$

$$\text{System average outage duration; } r_s = \frac{\lambda_1 r_1 + \lambda_2 r_2}{\lambda_1 + \lambda_2} \quad \dots(7.40)$$

$$\text{System average total outage time; } U_s = \lambda_s r_s \quad \dots(7.41)$$

If the two components are connected in parallel then:

$$\text{System outage rate; } \lambda_p = \lambda_1 \lambda_2 (r_1 + r_2) \quad \dots(7.42)$$

System average total outage duration,

$$r_p = \frac{r_1 r_2}{r_1 + r_2} \quad \dots(7.43)$$

$$\text{System average outage time, } U_p = \lambda_p r_p \quad \dots(7.44)$$

System Under Maintenance Mode

The component outage due to planned/preventive maintenance is considered as failures. Also, the maintenance outage cannot occur if there is some outage (say breakdown outage)

already existing in the system. Assuming the outage rates and outage durations under maintenance of components 1 as λ_1^n, r_1^n and component 2 as λ_2^n, r_2^n the equivalent (combined effect of breakdown repair and preventative/planned maintenance) outage rates and outage durations of component 1 (λ_{e1}, r_{e1}) and component 2 (λ_{e2}, r_{e2}) are:

$$\lambda_{e1} = \lambda_1 + \lambda_1^n \quad \dots(7.45)$$

$$\lambda_{e2} = \lambda_2 + \lambda_2^n \quad \dots(7.46)$$

$$r_{e1} = \frac{\lambda_1 r_1 + \lambda_1^n r_1^n}{\lambda_1 + \lambda_1^n} \quad \dots(7.47)$$

$$r_{e2} = \frac{\lambda_2 r_2 + \lambda_2^n r_2^n}{\lambda_2 + \lambda_2^n} \quad \dots(7.48)$$

The outage rate and outage duration of a system having two components with maintenance in series configuration are given by:

$$\lambda_{ms} = \lambda_{e1} + \lambda_{e2} \quad \dots(7.49)$$

$$r_{ms} = \frac{\lambda_{e1} r_{e1} + \lambda_{e2} r_{e2}}{\lambda_{e1} + \lambda_{e2}} \quad \dots(7.50)$$

And for parallel configuration it is expressed as:

$$\lambda_{mp} = \lambda_2 \lambda_{e1} r_{e1} + \lambda_1 \lambda_{e2} r_{e2} \quad \dots(7.51)$$

$$r_{mp} = \lambda_{e1} \lambda_2 \frac{r_{e1}^2 r_2}{\lambda_{mp} (r_{e1} + r_2)} + \lambda_{e2} \lambda_1 \frac{r_{e2}^2 r_1}{\lambda_{mp} (r_{e2} + r_1)} \quad \dots(7.52)$$

A practice that existed over many years to measure the performance of system using the basic reliability indices expressed by equations (7.34) to (7.52) have led to introduce more consistent criterion based on probabilistic considerations for power distribution system reliability evaluation. The new generation of service indices provides a fruitful comparison of the performance statistics collected and to predict the future system performance. The new generation indices used are: System Average Interruption Duration Index (SAIDI), System Average Interruption Frequency Index (SAIFI), Customer Average Interruption Frequency Index (CAIFI), Customer Average Interruption Duration Index (CAIDI) and Average Service Availability Index (ASAI).

The service indices mentioned above can be calculated using the three basic indices described earlier and can be expressed as follows:

$$\text{SAIFI} = \frac{\text{Total No. of customer interruptions}}{\text{Total No. of customers served}} \quad \dots(7.53)$$

$$\text{SAIDI} = \frac{\text{Sum of customer interruption durations}}{\text{Total No. of customers served}} \quad \dots(7.54)$$

$$\text{CAIFI} = \frac{\text{Total No. of customers interruptions}}{\text{Total No. of customers interrupted}} \quad \dots(7.55)$$

$$\text{CAIDI} = \frac{\text{Sum of customer interruption durations}}{\text{Total No. of customers interrupted}} \quad \dots(7.56)$$

$$\text{ASAI} = \frac{\text{Customer hours of available service}}{\text{Customer hours demanded}} \quad \dots(7.57)$$

QUESTIONS

1. With example discuss series reliability model.
2. What is the significance of parallel reliability model in reliability analysis?
3. Discuss the series-parallel reliability model with suitable example.
4. What is the decomposed reliability model? Explain briefly.
5. How redundancy concept can be applied in reliability evaluation? Explain.
6. Discuss different types of redundancy being used in practice.
7. Where Markov reliability models can be used effectively? Discuss.
8. What is the importance of reliability indices? Explain briefly.

**This page
intentionally left
blank**

Electronics System Reliability

INTRODUCTION

The design and manufacturing of an electronic equipment, more than any other branches of engineering, involves the utilization of very large number of components which are similar in design, but over which the designer and production engineer have very little control. The designers normally use catalogued items for their products. The reliability of the device used can be controlled to a large extent in the procurement and manufacturing phase but, mainly by quality control methods. The circuit designer generally has little control over the design reliability of the device. Now-a-days, very complex electronic systems are produced, where integrated circuit (IC) are replaced by large scale integration (LSI) and very large scale integration (VLSI) circuits. This has led poor reliability of the electronic systems. However, this is changing in some respects as system designs are increasingly implemented on custom-designed or semi-custom integrated circuits. Here, the role of design engineer for electronic systems have increased many folds where the involvement of other technologies, production, quality control, test planning, reliability engineer etc. has become pertinent. Because, without the support of the team, the reliability of designed product will be poor.

For the majority of electronic components/items the major determinant of reliability is quality control of all of the production processes. This is also true for other items, but non-electronic components can be inspected and tested during their manufacture. Whereas, electronic equipment cannot easily inspected since, they are nearly always encapsulated. In-fact apart from X-ray inspection of parts for Ultra-high reliability products, internal inspection is not generally possible. Since, electronic components once encapsulated, cannot be inspected and since, the complexity of the system desires precision and high production rates it is inevitable that production variations will be built into the component population. However, failures can be detected by automatic or manual testing.

Consider a typical failure mechanism in electronic device i.e., a weak mechanical bond of a lead-in conductor to the conducting material of the device e.g. resistor, a capacitor, a transistor or an IC. Such a device may function properly during quality inspection and testing, but may fail in due course of time, due to mechanical stress or over heating due to high current density at the bond. Other failure mechanisms lead to this sort of effect e.g. flaws in semiconductor material and defective hermetic sealing. Similar type of defects do occur in other systems but do not predominate as in case of electronic devices. Here, the failure time is likely to be affected by the voltage applied across it, the ambient temperature around the device and mechanical loading e.g. vibration. Other failure mechanisms, say a flaw in a silicon crystal, may be accelerated mainly by temperature variations. Defects in devices can result

in high localized current densities, leading to failure when the critical value for a defective device is exceeded.

The main difference between electronic and mechanical reliability is that the electronic equipments/systems do not wear out generally. While there are debatably some wear out mechanisms such as electro migration and component parameter drift, electronic equipment behave fundamentally different than mechanical ones. However, some components do wear out, such as electronic capacitors. Reliability cannot be after thought. It must be a goal from beginning of the design phase. Subsystems most commonly tend to wear from environmental exposure such as corrosion, fracture of connectors etc. This can be result of extreme temperatures, humidity, salt spray, moisture, dust, sand vibration, shock and electromagnetic interference. Care must be taken not to expose designs to conditions outside their rated space. Thus, tolerance levels have to be defined based on design expectations.

Over a time, high current densities in thin film conductors can cause voids or hillocks. Integrated circuits can undergo electromigration. Furthermore, when combined with environmental effects are of much concern. Transient stresses such as Electro Static Discharge (ESD) and lightening can also cause failures. Therefore, critical circuits are to be designed with a level of tolerance that can cope with parameter drift of components.

Electronic components generally have decreasing hazard rate, due to rejection of defective items and at the same time repairable electronic components also have decreasing failure rate since, the same are replaced during repair period. Wear out is a seldom a characteristic of a 'good' electronic equipment/system.

It is observed that unreliability of electronic equipment is not mainly due to defective components. The designer has to ensure that the load applied to components is within the specified limits, under steady state conditions. Since, the reliability of electronic components/items can be affected by temperature, design to control temperatures, particularly localized 'hot sport is necessary. Besides, load the other reason of failures can be drifts in components, short circuits due to solder defects or inclusions in components, high resistance or connector contacts, tolerance mis-matching, and electromagnetic interference and some of the examples.

RELIABILITY OF ELECTRONIC COMPONENTS

Electronic components can fail by most of the same mechanisms such as, fatigue, creep, wear, corrosion etc. as discussed earlier. Fatigue is main cause of failure of solder joints on surface mounted components and on connections to relatively heavy or unsupported components such as transformers, switches and vertically mounted capacitors. Wear affects connectors. Corrosion can attack aluminium conductors on ICs, connectors, on other components. Electrical and thermal stresses can also cause failures to electronic components. For all electrical and electronic components current flow causes, thermal and electrical stresses. Normally, electronic components do not fail during storage or use provided that they are:

- Properly selected and applied, in terms of performance, stress and protection.
- Not defective or damages during assembly.
- Not over stressed or damaged in use.

In 1950's, when the electronic systems were becoming more complex and semiconductor components were in their infancy, the failure rates of such component was very high. But today the quality of manufacture of modern electronic equipment is so high that their proportions that might be defective in any purchased quantity are typically very low. Therefore, the potential reliability of well-designed, well-manufactured electronic systems is extremely high.

COMPONENT TYPE

The type of components and circuits used in electronic system are the following:

Integrated Circuits(ICs)

These are basically sub-systems, containing tens to millions of transistors, capacitors, and other discrete components. These are classified as: Small Scale Integration(SSI) up to 100 logic gates; Medium Scale Integration(MSI); up to 1000 gates; Large Scale Integration(LSI) up to 10,000 gates Very Large Scale Integration(VLSI); more than 10,000 gates. Currently microprocessors contain over 10 million transistors. VLSI chips possess unlimited range of potential functions.

The construction of ICs, includes the selective diffusion into silicon wafer of areas of different charge level, either by ionic diffusion in furnace or by implantation by a charge particle accelerator. The later method is used for large scale production. In the diffusion process, the areas for treatment are defined by masks. A sequence of treatments, with intermediate removal by chemical etch of selected areas, creates, the structure of transistors and capacitors.

Different layers of diffusion process are electrically isolated by layers of silicon dioxide (SiO_2). This is called passivation. Finally, the entire die surface apart from connector pads for the wire bonds, is protected with a further SiO_2 or Si_3N_4 layer. This process is called as glassivation.

The Connections between transistors on the chip and to the input and output pins are made via a network of aluminium conductor tracks, by depositing a thin layer of metal (metallization) on to the surface through a mask.

Finally, the assembly is packaged in either plastic moulding or in a hermetic (ceramic or metal) package.

The first ICs were produced in 1970's and 1950's with simple analogue and digital circuits with defined functions (op-amps, adders, flip-flops, logic gates etc.). But now the classes available include:

- Standard ICs. Examples are logic, memories, microprocessors analogue to digital convertors, signal processing devices, op-amp etc.
- Programmable Logic Devices (PLDs), Field Programmable Gate Arrays (FPGAs)
- Mixed Signal (ICs). Have both digital and analogue circuits integrated into the same chip.

Microwave Monolithic ICs (MMICs): Used in telecommunications and contain microwave radio circuits.

Complex multifunction devices (System on chip) may contain mixed technologies. Such as processing, memory, analog-digital conversion, optical conversion etc.

Application specific ICs (ASICs)

They are designed and fabricated for specific application and to introduce important reliability aspects. Here, failure modes can be simulated at the design stage and effects evaluated, so stress analysis and FMECA can be integrated with the design process.

Microelectronic Packaging

These are of two types (i) hermetic packaging where die is attached to the package base, usually by soldering, wire bonds are connected between the die connector pads and leadout conductors, and the package is then sealed with lid (ii) Plastic encapsulated ICs (PEICs or PEDs) use an epoxy or silicon encapsulant which are used for in high temperature environment or moisture environments or where long life is important.

New packaging techniques have been developed with automation of the assembly processes in mind more recent developments are the pin grid array (PGA) and ball grid array (BGA) packages. Leadouts are taken to array of pins on the under side of the package on a 1.25 mm or less grid. Other packaging methods are used for special applications, such as vertical mounting of high frequency circuit, direct mounting of the chip on to the PCB or substrate (flip chip) and chip scale packaging (CSP).

The main reliability implication of new IC packaging technologies is the fact that, as the volume per function is decreased, the power dissipation per unit volume increases. This can lead to difficult thermal management problems in order to prevent junction temperatures attaining levels above which reliability would be seriously affected. Liquid cooling of assemblies is now necessary in some applications such as some military and high speed computing and testing equipment.

Another reliability aspect of new method is the use of reflow soldering to the surface of PCB or substrate. Solder connections cannot be inspected as can DIL solder connections, with a PGA or BGA they cannot be seen at all. Also, thermal cycling can cause the solder joints to fail in shear, since there is no mechanical compliance as with the pins on a DIL. Therefore, the solder process must be carefully, controlled, and subsequent burn-in and reliability tests must be designed to ensure that good joints are not damaged by the test conditions.

Hybrid microelectronic packaging/multichip modules

This is a technique for mounting unencapsulated semiconductors and other devices on ceramic substrate. Resistors are made by screen-printing with conductive in and laser trimming to obtain the desired values. Connections are made from fine gold or aluminium wire and finally complete assembly is then incased in the hermetic package.

Hibrid package provides certain advantages over other methods being rugged because of encapsulation. No repair can be done on these circuits and therefore suitable where only replacement is possible. These are used in missile electronics, automotive engine controls and severe environmental industrial conditions.

Microelectronic component attachment

Components can be soldered on PCB or plugged into IC sockets which are soldered in place. However, plugging has added advantages, such as component replacement, easy testing and diagnosis and possible modifications. But at the same time some drawbacks include heat transfer degradation, electrical contact problem and risk of damaging ICs.

MICROELECTRONIC DEVICE FAILURE MODES

Following are the some of the failure modes which take place for electronic devices:

(i) Electro migration (EM)

It might be considered a wear out mechanism because of bulk movement of conductor material, at the level of individual metal crystals, due to momentum interchange with current carrying electrons. This can result in local narrowing of the conductor track, and thus increased local current density and eventual fusing. Also, the displaced material can form conducting whiskers, which can cause a short circuit to a neighbouring track. The EM process can be quantified using Black's law.

$$T_m = [A(W)^{F_N}] \exp [E_A/kT] \text{ where,}$$

$$J = \text{current density (A/m}^2\text{)}$$

$$N = \text{empirical constant, between 1 and 3}$$

$$A(W) = \text{material constant, a function of line width}$$

$$E_A = \text{activation energy.}$$

EM is an important mode in electronic systems which must operate for long times, at high temperatures such as space controls, and telecommunications systems.

(ii) Transient electrical stresses

Modern electronic components are prone to damage from high currents due to their delicate nature and inability to sink heat. Thus, transient stresses such as those due to electro static discharge (ESD), lightning, and power supply transients from switching or lightning can cause system failures.

Some methods to protect against transient voltage include:

- Capacitors to absorb high frequency transient
- Opto—couplers to isolate sensitive portions of electrical system from damaging transients.
- Resistors
 - (i) between inputs and external connections to reduce transient voltage levels and
 - (ii) between outputs and external connections to prevent excessive currents in the case of a short to ground.

(iii) Excessive heat

The temperature from 80°C to 150°C is treated as high temperature range, therefore, thermal design can be important aspect of a system's over design. Components generate in operation and when combined with ambient temperature and solar radiation, excessive temperatures can be attained. Common methods to provide thermal protection include.

- (i) Heat sinks for components that give off considerable amount of heat.
- (ii) The use of a thermal condition plane. Thermal conduction planes within printed circuits boards conduct heat away from generating components.
- (iii) Fans to improve airflow through enclosure.
- (iv) Liquid cooling for high power devices giving off large amount of heat.

(iv) Latch up

It is creation of low resistance path between the power input and ground in an IC. CMOS ICs are prone to this failure mode when subjected to transient voltage over stress caused by ESD or other transient pulses from circuit operation, test equipment etc. The effect is permanent failure of the device.

(v) Electromagnetic interference (EMI)

Electrical systems can emit electromagnetic radiation that can cause interference to itself or other systems. Particularly in digital systems, a conductor acting as an antenna can pick up electromagnetic signals and corrupt digital data. Thus to produce reliable electronic systems, emission of EMI must be limited as well as the system's susceptibility to it. There are many different sources of EMI and one should consult a text on EMI for full understanding of how to cope with it. Some of these sources include electric motors, emission from amplifiers electrostatic discharge, radiation from spark plugs, radars and transformers.

Some ways to protect against EMI emission are:

- Suppression
- Screening

Some ways to limit EMI susceptibility are:

- Screening
- Filtering of unwanted frequencies
- Isolation by opto-couplers
- Careful design, taking into account layout, packaging etc.

- (vi)** Time-dependent dielectric breakdown (TDDB) is a failure mode of the capacitors within ICs caused by whiskers of conductive material flowing through the dielectric (Silicon dioxide) and eventually short circuiting the device. The effect is accelerated by voltage stresses and by temperature.
- (vii)** Slow trapping is the retention of electrons in the interstitial boundaries between Si and SiO₂ layers in ICs which cause incorrect switching in digital logic and memory applications.
- (viii)** Hot carriers are electrons (or holes) that have sufficient energy to overcome the energy barriers of Si-Si and SiO₂ boundary, and become injected into the SiO₂. These effects are to increase switching times in digital devices and to degrade the characteristics of analog devices. This effect can be minimized by process design techniques and by circuit design, which will reduce voltage stress at critical locations.
- (ix)** Soft errors are the incorrect switching of memory cell caused by passage of cosmic ray particles or alpha particles which can be corrected by refreshing the memory.
- (x)** Processing problems in manufacture (diffusion, metallization wire bonding, packaging etc.) can cause variety of other failure mechanisms, which may cause data loss or complete failure of the device.

Depending upon the applications of the electronic devices their specifications are provided on temperature rating. For example, military grade devices are rated between -55°C and $+125^{\circ}\text{C}$ so that hermetic package is necessary. Industrial grades are rated typically between -25°C and $+85^{\circ}\text{C}$ and commercial grade between 0 and 70°C .

Electronic systems must be designed to withstand mechanical shock, vibration, humidity and other environmental stresses. Since, solder has rather poor fatigue properties, heavy components should be given extra support rather than simply relying on solder connections. Furthermore, cables need to be carefully supported and strapped down to avoid wear due to moving parts. Connector failure is often a common cause for electrical system and attention should be paid to their placement and mounting.

CIRCUIT AND SYSTEM ASPECTS

Circuit design for electronic systems should be such that, it minimizes distortion, component failures or parameter variations etc.

(i) Distortion and Jitter

Distortion is any change in the shape of wave form from the ideal. It can be caused by many factors such as, mismatched input and output impedences, cross over distortion in transistors, optical devices and op-amps, transistor saturation, interference, thermal effects etc.

Jitter is a form of distortion that results in an intermittent variation of wave form from its ideal position, such as timing, period or phase instabilities, and can effect high speed circuits.

Timing

It is an important aspect of most digital electronic circuit design. For proper working, the input and output voltage pulses to and from circuit elements must appear at the correct times in the logic sequences, which is possible by design for simple circuits. However, as speeds and complexity have increased, it is difficult to ensure that every pulse occurs at correct time and sequence. The integrity of pulse wave form also becomes more difficult to assume at high frequencies. Any digital circuit will have a speed above which it will begin to perform incorrectly. At higher assembly levels, such as telecommunications or control systems, further limitations on speed of operation can be caused by inductive and capacitive effects within the circuit by propagation delays along conductors.

(ii) Electromagnetic interference and compatibility

Electromagnetic interference (EMI) is the disturbance of correct operation caused by changing electromagnetic fields or other electrical stimuli, which are then received by signal lines and so generate spurious signals. It is also called 'noise'. Electromagnetic compatibility (EMC) is the ability of circuits and systems to withstand these effects. It is also called electromagnetic immunity.

EMI can be generated by many sources such as:

- High frequency radiation from switching within components transmissions from data lines and oscillators. Every component is a potential transmitter and a potential receiver, which is called cross-coupling.

- Transient differences between voltage potentials on different parts of the circuit ground plane, due to inductive or capacitive effects.
- Electromagnetic emissions from RF components or subsystems when these are part of a system.
- Switching of inductive or capacitive loads such as motors on the same power circuit.

The operating frequencies of modern digital systems are in the radio frequency range (500 MHz to over 1 GHz) and harmonics are also generated. Circuit design to prevent EMI is a difficult and challenging aspect of all modern system designs.

Intermittent failures

These failures mostly occur in modern electronic systems, which are caused by connectors that fail to connect at sometimes, such as under vibrations or at certain temperatures, broken circuit card tracks that are intermittently open circuit, tolerance build effects between component parameters etc. Sometimes, detection of failures is difficult, and faulty units are not repaired and can cause system failure when reinstalled.

Other failure causes may include the followings:

- Failures of vacuum devices (CRTs, light bulbs and tubes etc.)
- Failures of light bulbs due to sputtering of filament material
- Failures due to non-operating environments.

RELIABILITY IN ELECTRONIC SYSTEM DESIGN

To design a reliable electronic system the designer must consider the following main aspects:

- (i) Electrical and other stresses, particularly thermal on components to avoid over stressing during operation.
- (ii) Variation and tolerances of component parameters values, to ensure proper functioning of the circuits.
- (iii) The effects of non-stress factors, such as electrical interference, timing and parasitic parameters, particularly for high frequency and high gain circuits.
- (iv) Ease of manufacture and maintenance and tests.

The other aspects for better reliability can be reduction in number of different part types, the part selection effort can be reduced and design becomes easy to check and verify. Redundancy can also be designed into circuits. Whenever, practicable the need for adjustments or fine tolerances should be avoided. The various design options relevant to reliability must be considered in relation to their effectiveness, cost and the consequences of failure. The design engineers should consult reliability engineers before a circuit is designed and developed. However, the following will help the design engineers.

Transient voltage protection

It is observed that electronic equipments/systems are prone to damage by short duration high voltage transients, caused by switching of boards, capacitive or inductive effects, electrostatic discharge(ESD), incorrect testing etc. Small components are more vulnerable because of low thermal interiors.

Logic devices require voltage protection, which can be provided by a capacitor between voltage line to be protected and ground to absorb high frequency transients (buffering), diode

protection, to prevent voltages from rising beyond a fixed value (clamping) and series resistances, to limit current values. Fig. 8.1 shows such protection where D1 diode prevents the input voltage from rising above the power supply voltage. Capacitor C1 absorbs high frequency power supply transients.

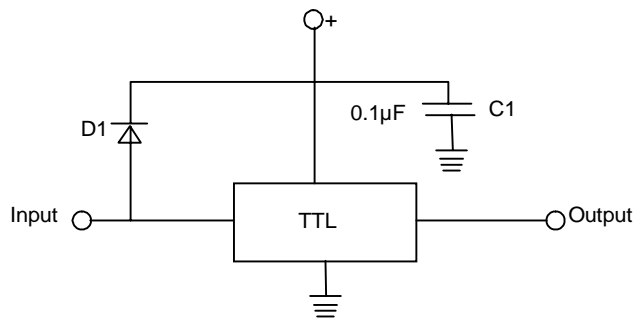

Fig. 8.1: Logic device protection

The transient voltage levels which can cause failure of semiconductor devices are referred to a VZAP, whose value depend upon transient duration, which are available in the data books of the manufacturer. It can be controlled by incorporating the following circuit. Resistor R1 limits the base current I_b and capacitor C1 absorbs power supply high frequency transients.

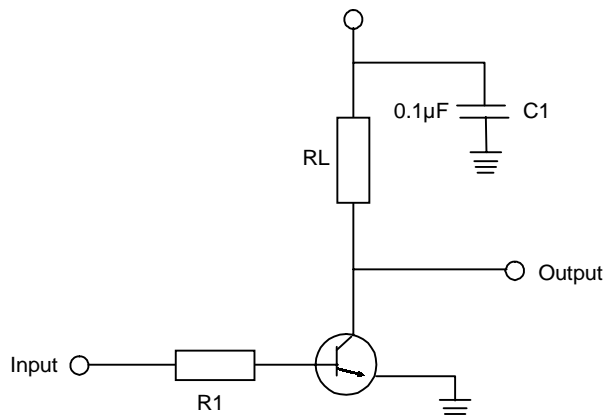

Fig. 8.2: Transistor protection

Very high voltage potential components should be handled with adequate ESD precautions at all stages and that protection should be designed into circuits to safeguard components after assembly otherwise, triboelectrical effects can be the causes of their failures. ESD can also damage the components during handling and therefore due care should be taken when the components are unpowered. Warning levels should be fixed to packages and equipment.

Thermal design

As has been discussed earlier that most of the electronic components are susceptible to high temperatures, therefore this aspect must be given due attention during design stage. Because

high temperatures can accelerate failure modes in marginally defective components and can also cause thermal fatigue of bonds and component structures, particularly if there are high local temperature gradients.

The maximum temperature generated in the system depends on the electrical load and environmental temperature. Temperature at the active area of device, for example function of a power transistor, or averaged over the surface of an IC can be calculated using the formula.

$$T_j = T_A + \theta W$$

Where T_j is the local temperature at the active region, T_A is the ambient temperature around the component, W is power dissipation, and θ is thermal resistance between the active region and the ambient, measured in °C per watt.

To provide thermal protection the devices can be mounted on a heat sink, typically a metal block, with fins to aid conductive and radiant heat dissipation. Some of the parts are provided with integral heat sinks such as, power transistors. Small fans are also used to cool microprocessors, further protection can be provided by temperature sensitive cut off switches or relays. In sensitive devices, copper heat planes are incorporated into the PCB to allow heat flow from the components. In extreme cases liquid cooling is also used.

Temperature control can be greatly influenced by the layout and orientation of the components and sub-assemblies such as PCBs. Hot components should be positioned downstream in heat flow path and PCBs should be aligned vertically to all conductive air flow. Fans are generally used to circulate air in electronic systems.

Before design, all aspects related to temperature rise from the components must be examined, as well as heat inputs from all heat generating components, external sources such as solar radiations should also be given due care. Thermal modelling software should be used using finite element methods to map thermal aspects of the PCBs.

Thermal evaluation is important for any electronic design when components are subjected to high temperature range.

Stress derating

It is the practice of limiting the stresses which may be applied to electronic components, to levels below the specified maximum, to improve the reliability. The values of derating stress are expressed as ratios of applied stress to rated maximum stress, whereas, thermal derating is expressed as a temperature value.

Derating enhances reliability by:

- (i) Reduction in components failure during service life.
- (ii) Reduction in parameter variation effects.
- (iii) Reduction in long term drift in parameter values.
- (iv) Allowances for stress calculations.
- (v) Provision of protection against transient stresses.

In all cases manufacturers data handbook should be consulted for details so far specified values are concerned. However, if stress values near to rated maxima must be used it is important that the component is carefully selected and purchased, and that stress calculations are doubled-checked.

Electromagnetic interference and compatibility (EMI/EMC)

Circuit design to prevent EMI is a difficult and challenging aspect of all modern electronic system design.

The main design techniques are:

- The use of filter circuits
- Shielding of circuits and conductors
- Balancing of circuit impedances
- Grounding of all circuits
- Selection of micro switches and relays
- Noise filter for digital systems
- Use of optical fibers for data transmission
- Coding system for software driven systems.

For the purpose of EMI/EMC analysis softwares are available and national and international regulation exist to set standards for electromagnetic and power line emissions with test methods.

Redundancy

In the electronic circuits and system redundancy can be applied from component level to subsystem, however, it depends upon the criticality of the system. But reliability improvements are possible by the application of the redundancy comparatively at low cost. The most likely component failure modes must be considered, for example resistors in parallel will provide redundant, though possibly degraded operation if one becomes open circuit and short circuit is unlikely failure mode opposite consideration apply to capacitors.

Design Simplification

The main aim of the designer should be to make simple design for electronic systems. Simplification here means reduction in number of components and their connections should improve reliability as well as reduce production costs. However, the need to provide adequate circuit protection and component derating, and where necessary redundancy, should be taken priority for overall system effectiveness.

Minimizing the number of component types is an important aspect of design simplification. But different designers contribute to a system different solutions to similar design problems will be used, resulting in a larger number of component types and values being specified than necessary and will lead to higher cost of production and maintenance. It can also reduce reliability of the system since quality control of brought in parts will be difficult. Design rules can be written to assist in minimizing component types, by constraining designers to preferred standard approaches and component reduction should be made the objective of the design review.

Sneak Analysis

A sneak circuit is an unwanted connection in an electrical or electronic circuit, which may be by virtue of designers mistake or inadvertently designed in case of complex circuits. Sneak analysis is a technique to identify such circuits and in operating software. It is based on the identification within the system of 'patterns' which can lead to sneak condition. There are five basic patterns as shown in Fig. 9.3.

Any circuit can be considered as being made of combinations of these patterns. Each pattern is analysed to detect if conditions could arise, either during normal operation or due to a fault in another part of the system, that will cause sneak. For example, in the power dome or combination dome the power sources could be reversed, if S_1 and S_2 are closed.

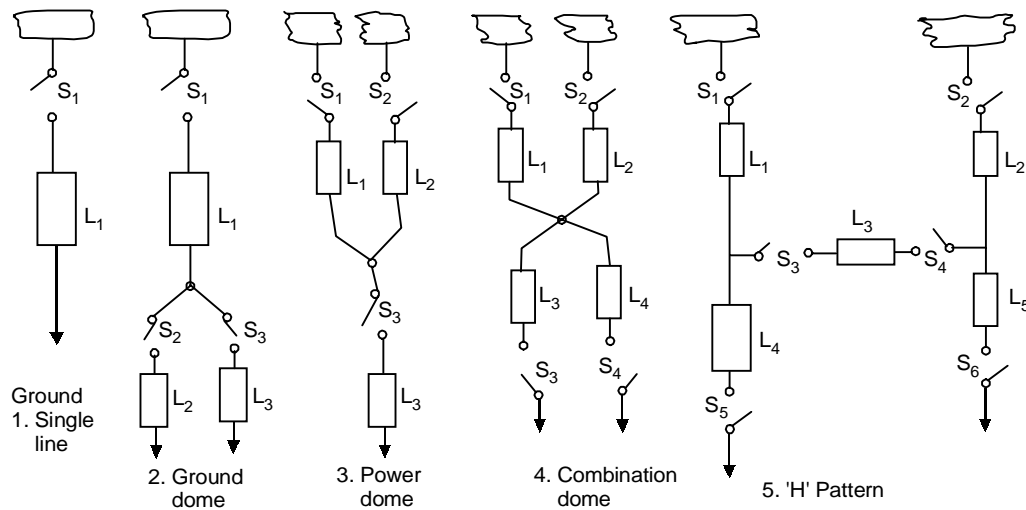

Fig. 9.3: Sneak analysis basic patterns (hardware)

1. **Sneak paths:** Current flows along an unexpected route.
2. **Sneak opens:** Current does not flow along an expected route.
3. **Sneak timing:** Current flows at the incorrect time or does not flow at the correct time.
4. **Sneak indications:** False or ambiguous indications.
5. **Sneak levels:** False, ambiguous or incomplete labels on controls or indicators.

When potential sneak conditions are identified, they must be validated by test or detailed investigation, reported and corrective action must be considered. Sneak analysis is a tedious job and should be performed on large systems. But it has proved very beneficial in safety analysis for aircraft controls etc. Now software's are available to help the designer during the design stage particularly while using computer aided design procedure. Sneak circuits can be avoided by careful design or detected by adequate testing.

PARAMETER VARIATION AND TOLERANCES

All electrical parameters of electronic components are subject both to initial component-to-component variation and sometimes to long term drift. Parameter value can also vary due to temperature variations during use of components. Variations of these parameter will have due importance during design phase but also will depend upon its application also. For example, the resistance value of resistor in a feedback current of high gain amplifier might be critical for current operation, but would not need to be as closely controlled in a resistor used as a current limiter.

Initial variations can be because of production process but controlled parameters are measured at the end of production. If the parameters variation are higher than specified

limits, the lots are rejected. A distribution of the parameters can be drawn to select or reject a lot, which will depend upon its, application. For many component parameters for example transistor characteristics, maximum and minimum values are stated. All parameters cannot controlled during production/manufacture but are given their typical values. Therefore, it is not advisable to design critical circuit operation around such parameters, since they cannot be measured.

Since, the conductance, both of conductor and of semiconductor materials, varies with temperature, all associated parameters will also vary. Therefore, resistance of resistors, and gain and switching time of transistors, are typical of temperature-dependent parameters. High temperature can also increase noise outputs.

Parameter drift with age is also associated with changes in conductance, as well as in dielectric performance, so that resistors and capacitors are subject to drift, which also depends on materials used and production process as well as operating temperature and time.

There are some other circuit parameters which are not intrinsic to the theoretical design of the component or the circuit but are due to fabrication and layout features and are called as parasitic parameters. And their effect can be very important, and difficult to control, in high gain and high frequency systems.

Parameter variation can effect circuits in two ways. For circuits which are manufactured in large quantity, many of which may not meet the required operating specifications and may lead to higher production cost. These variations can also cause circuit failure and therefore poor reliability of the electronic system.

Tolerance Design

Every electronic circuit design must be based on the nominal parameter values of all the components used and will contribute to correct performance. This is parameter designs. It depend upon the knowledge and inventiveness of the designer. However, having created functional design, it is necessary to evaluate the effects of parameter variation on yield, stability and reliability, which is called as tolerance design.

The first step in tolerance design is to identify sensitive parameter values which will effect the performance and yield. It can be considered during the parameter design stage and can be calculated. Designers experience will make this task simple and easy. However, systematic approaches must be used for serious design.

The next step is to determine the extent of variation of all the important parameter values, by reference to the detailed component specifications. Sometimes, this is neglected by the designers, and only primary nominal value and tolerances, without full details are being used. However, all parasitic parameters should also be evaluated at this stage.

The other aspect of design can be with the use of adjustable components, which make system complex and less reliable, since these components are prone drift. Wear, vibration and contamination etc., can be other reasons for their poor performance. However, components such as, thermistor and variable resistors fall under this category. Wherever possible the design should aim for minimum performance variation by the careful selection of the parameter values and tolerances.

Analysis Methods

The analysis of tolerance effect is very much important from design point of view. Some methods are discussed below to analyse the effects of variation and tolerances in electronic circuits.

Worst case analysis (WCA)

This method involves evaluation of circuit performance when their values are at highest and lowest tolerance values, which is extension of parameter design calculations but used only for simple circuits only. Digital circuits are easy to analyze where, frequency and timing requirements are not too severe. However, when parameters variation is important more powerful methods must be used.

The Transpose Circuit

The sensitivity of output of circuit parameter changes can be analyzed by this method. It is a circuit which is topologically identical to that under investigation, except that the forward and reverse transmission coefficients of each 3-terminal device are interchanged, the input is replaced by an open circuit and the output by a current source of IA. These circuits use Tellegen's theorem for checking the sensitivity.

Simulation

Using Monte Carlo simulation method the effects of tolerances and variation in parameters can be examined using softwares. These modern softwares allow parameter variations to be set, either as a range or a defined distribution shape (e.g. normal, bimodal) and program then randomly 'build' circuits using parameter values from the distributions and will analyze these. This method evaluates the effects of multiple simultaneous variations. Refinements allow most critical parameters to be identified and statistically designed experiments can be seen. Circuits can be analysed in the time and frequency domains and there are no practical limitations apart from the time required for each analysis on the number of parameters input conditions and simulations.

QUESTIONS

1. Discuss the importance of reliability for electronic components/systems.
2. Explain various types of components used for electronic system.
3. Describe in detail the failure modes for electronic components.
4. What aspects are necessary for the circuit design of electronic systems?
5. How the concept of reliability can be introduced in electronic components/systems? Also discuss failure of solder connections.
6. Explain how reliability of the electronic components be improved?
7. How parameter variations can be taken care off during the design stage? How the effects can be minimized?
8. How temperature effect can be controlled during the design of electronic circuits?
9. Describe any two methods for analyzing the effects of component parameter variation on the performance variation on the performance of electronic circuit.

Reliability Prediction Analysis

INTRODUCTION

The reliability analysis can be used to define the quantitative parameters for an item, equipment or a complete system and may be expressed in number of failures in a given period of time, set number of cycles or set number of operations, such as rounds fired from a small caliber gun etc.

A common expression used to define components reliability is its Mean-Time-Between-Failure (MTBF). Once this figure is known it can be used to determine the reliability of component in terms of probability of success or failure, over a given operating period.

MIL-HDBK-217 is a standard database of failure rates for electronic components, which was developed the USAF Rome Air Development centre. This provides constant hazard rate models for all type of electronic components/systems, taking into account factors that are considered likely to affect reliability. It assumes independent, identically exponentially distributed, times to failure for all items.

The general failure rate model is:

$$\lambda_p = \lambda_b \Pi_Q \Pi_E \Pi_A \quad \dots(9.1)$$

Where λ_b is base failure rate related to temperature and $\Pi_Q \Pi_E \Pi_A \dots$ are factors which take account of part quality level, equipment environment, application stress etc.

The relationship of failure rate to temperature is based upon the model for temperature dependent physical and chemical processes (diffusion, reaction) due to Arrhenius.

$$\lambda_b = K \exp\left(\frac{-E}{KT}\right) \quad \dots(9.2)$$

Where λ_b is the process rate (component 'base' failure rate), E the activation energy (ev) for the process, K, Boltzmann's constant ($1.38 \times 10^{-23} \text{ J.K}^{-1}$ or $8.63 \times 10^{-5} \text{ eV.K}^{-1}$). T, the absolute temperature and K is constant.

Detailed models are provided for each part type, such as microcircuits, transistors, resistors, connectors etc. For example, the microelectronic device failure, rate model is:

$$\lambda_p = \Pi_Q \Pi_L [C_1 \Pi_T + C_2 \Pi_E] / 10^6 \text{ hr} \quad \dots(9.3)$$

Where Π_L is learning factor, Π_T is temperature factor, C_1 is a complexity factor based on the chip gate count or bit count for memory device or transistor count for linear devices, C_2 is complexity factor based upon package aspects (number of pins, package type).

However, these data base and models have errors for the following reasons:

- (i) Failures of modern electronic systems is not due to internal causes.
- (ii) Temperature dependence of failure rate is not supported by modern experimentations.
- (iii) Several other parameters used in models are of doubtful validity. For example, it is not true that failure rate increases significantly.
- (iv) Models do not take care of parameters such as, overstress temperature cycling, variation EMI/EMC, and control of assembly, test and maintenance.

RELIABILITY ANALYSIS

There are methods available for determining the reliability of an item (this could be a piece part to a complete system) and are:

Reliability Prediction—This is the process used to determine MTBF of an item. This is achieved by performing a prediction analysis.

Similarity—This method is used to determine what the reliability of a new product will be based upon the 'Known' reliability of existing product with similar attributes. These attributes can be the type of technology used, digital circuitry, complexity of components and also comparable operating environments and scenarios.

Field Data — For reliability analysis the most important parameter is the data, which should be authentic and accurate because the correct or incorrect analysis will depend on the data collected. Normally organizations would establish a process designed to collect fielded data. The MTBF will be calculated by dividing the total cumulative operation hours for all fielded products by the number of failure occurrences. Where data are not available the same can be either generated through simulation or information about similar equipment can be used.

Apportionment

The purpose of apportionment method is to assign reliability figure to an item/component. This is particularly useful in the early conceptual and design phase. The apportionment, allocates the reliability figure to the component in question; allowing overall budgetary control of a system's end reliability. This will also allow the development of reliability figures that could be introduced into the performance specifications for sub-systems. The apportioned reliability will be reviewed, as the design of the equipment becomes more solid.

Similarity

This method should also take into consideration the operational environment and quality of the product, of the new item and that to which it is been compared to. For instance an electronic computer module, has an Input Buffer Module (12 discrete inputs) and, is being designed for a new naval application. A previous module was developed for an aviation application, using the same component quality and density. As this item was previously developed for another project there is some reliability prediction data available. This data can be utilized for the new design, when it has been modified by a factor to take into account the differences between the two operating environments.

Prediction

Reliability predictions for electronic components can be achieved by using MIL – HDBK – 217 or Bellcore, (A military handbook) which also includes commercial. This book has been revised constantly over the years and is now at revision F, notice 2. The fundamental approach of this document is to commence the development of a reliability prediction, from discrete component upwards, using specific algorithms for generic electronic components.

In case of MIL-HDBK-217, there are two methods, a part count and a full stress. To implement either of two methods requires certain knowledge with respect to the electronic components and the maturity of the product design. The parts count is performed when for example, a printed circuit Board's design is such as to be able to determine the main component type, quality and quantity. This method makes general assumptions on the applied stresses for each electronic component.

The full stress method is invoked when the design of a Printed Circuit Board is nearly complete and subject to possibly only minor changes. This particular method evaluates the thermal and electrical stresses that are applied to a component under given environment conditions. This method will afford an analyst to assess if specific design practices are being adhered to such as stress detracting. Therefore, it is possible to identify if a component is being operated outside allowable stresses. For mechanical components implementing stress analysis will help to determine margin of safety and the safety factor for a particular item.

Part Count

This method is utilised in the early design phase when there is insufficient information available, thus not enabling a full stress method to be conducted. There is sufficient information or data available to allow the preliminary reliability prediction to be conducted. MIL – HDBK – 217 provides a set of default tables that provides a generic failure rate (λ_M) for each component type and is based up on the intended operational environment. This component generic failure rate is also modified by a quality factor (λ_Q), which represents the quality of components in question. In addition for microelectronic circuits a learning factor (Π_L) is used and represents number of years that a component has been in production. Using above factors final failure rate is established for each component. The summation of the individual component's failure rates will yield the overall failure rate for the circuit card assembly they populate. With this and the summation of other circuit card assembly failure rates, the failure rate of a line replaceable unit will be established. This process will provide an overall failure rate for a system.

Full Stress

This method, like the parts count method, provides a failure rate for an electronic component. The summation of failure rates for all components on a circuit card, and all the circuit cards, within a black box, and all the black boxes, within a system will yield the overall failure rate for a system. To enable a full stress analysis to be conducted there must be sufficient details on the system design available to the reliability engineer. In essence the design of the system must be such that the electronic and electrical design of the hardware is to the component level. There will be detailed parts lists and circuits schematics available. This is required because the stress analysis takes into consideration the electrical and thermal stresses that will be experienced by each component.

The full stress analysis is completed by the reliability engineer, who with the detailed knowledge of the electrical and electronic design, in addition will require specific data pertaining to each component type used within the design. Component information, or data sheets, are supplied by the manufacturer and recently this information is available on web. In case of full stress analysis the mathematical models are detailed in MIL – HDBK – 217 for each component type i.e., microelectronics, resistors, capacitors and electro/mechanical devices.

The general approach used by MIL – HBK – 217, is each generic component type is assigned a base failure rate (λ_b) and is modified by influential factors which is listed below. Some of the factors will result in a linear degradation of the base failure while others will cause an exponential degradation, in particular factors associated with temperature.

Π_E → Environment factor which will take care of working/operating environment condition of the equipment/system.

Π_Q → Quality factor, which looks up the quality of the component in question. Generally base failure is modified using this factor.

Depending on the type of component under study the base failure rate will be subjected to additional modification by various factors such as (MIL – HDBK – 217).

Π_{NR} → Represents the number of resistors in use on a resistor network.

Π_{TAFS} → Is a derived factor, representing the number of taps on a variable resistor.

Π_L → Represent a factor for the number of years that IC has been in production.

There can be various operating environments which are listed in MIL – HDBK – 217, the ones listed in Bellcore apply to commercial field.

Mathematical models in the form of algorithm 'given in MIL-HDBK-217 are being used for microcircuits that include Bipolar and MOS devices, digital and linear gate/logic arrays. Field Programmable Logic Arrays (PLA) and Programmable Arrays Logic (PAL) and Microprocessors.

RELIABILITY BLOCK DIAGRAM

A Reliability Block Diagram (RBD) is a graphical representation of how the components of a system are reliability-wise connected. As with any approach or methodology, reliability block diagrams have their advantages as well as disadvantages compared to competing methods. In order to address some of the current inadequacies in reliability block diagrams, perhaps it is time to revise the standard to make the methodology easier to use and also more effective. The reliability block diagrams can be drawn following the various configuration of the components/item in an equipment/system. These can be of the following types.

- Series, parallel and series parallel combination configurations.
- Complex configurations
- K out of N nodes
- Standby containers
- Load shared containers
- Subdiagram blocks to represent inheritance
- Multi blocks to save time and space
- Mirror blocks to simulate Bi-directional paths

Furthermore, now lot of softwares are available to draw reliability block diagrams, which may include Relex RBD's; item software.com; rediasoft.com; opsalacarte.com. Reliability software, ISO graph software etc.

When equipment/system has large number of components either in series or parallel, calculation of reliability for each component/item is a tedious job. Therefore, in such a case components/items are grouped according to their functional requirements and complete equipment/system is divided in the form of blocks. Then, it is possible to calculate the reliability of each block depending upon their configuration and functional requirements. Given below is an mechanical equipment (Dumper) used in construction work for shifting the material. Followings are the main components of which the reliability calculations are required.

1.Engine, 2. Compressor, 3. Valve Bank, 4. Transmission, 5. Brake, 6. Clutch, 7. Steering cylinder, 8. Body lift cylinder, 9. Suspension cylinder, 10. Body with canopy and frame and, 11. Wheels/tyres.

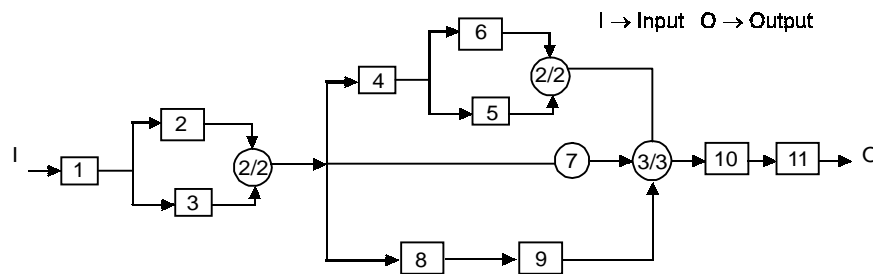

Fig. 9.1: Dumper Reliability Model

For the study purpose, the dumper is divided into following three functional units:

- Power generation unit (PGU) comprising of diesel engine
- Power development unit (PDU) Comprising of compressor
- Power utilization unit (PUU) Comprising of direct mechanical torque converter system for propel operation, hydraulic cylinders for steering/hoisting and hydraulic cylinders for dumper operation.

The block diagram of dumper reliability model is given above.

Having calculated the reliability of each component, the reliability of each functional group is calculated. This is expressed as

RPGU→Reliability of Power Generation Unit

RPDU→Reliability of Power Development Unit

RPUU→Reliability of Power Utilization Unit.

To calculate the reliability of the complete unit i.e., Dumper the following relationship is used.

$$R_D = RPGU \cdot RPDU \cdot RPUU \quad \dots(9.4)$$

Where R_D is the reliability of the Dumper unit.

In the same manner the reliability of the complex electronic equipment/systems can be calculated using the concept of block diagram. Which is the basic requirement for assesment of reliability.

ELECTRONIC RELIABILITY PREDICTION

There are different approaches for reliability prediction for electronic components. Each one of them has merits and demerits.

The estimation of product reliability requires knowledge about the components, the design, the manufacturing processes and operating condition in which system has to operate. Empirical prediction techniques based on modeling past experience and data present good estimate of reliability for similar or modified products but may not predict well for new products using new technologies or environmental conditions. The use of deterministic physics-of-failure techniques may predict wear out or end of life reliability unit accuracy, but are often difficult to use and do not predict failures in the other domains. Field operational data on the same or similar products is the best estimate of a product's reliability, but is difficult and expensive to collect or obtain.

The choice of methodology to be used to predict reliability are summarized in Table 9.1. The period of time that each method is effective is indicated by the use of check marks. The order of effectiveness by relative rank is determined by experience data and the number of periods for which the methodology is appropriate.

Obtaining a specific number should never be the sole purpose of a reliability prediction, rather identifying and controlling the factors affecting reliability should be considered even more important than the predicted number itself.

Table. 9.1: Reliability Prediction Methodologies

Rank	Method	Safety Defect	Random Events	Wear out	Description
1.	Test or Field Data	√	√	√	In-house test or operational data is used to estimate reliability of the product based on failures and time.
2.	System Reliability Assessment	√	√	√	Consolidated assessment technique.
3.	Similar Item Data	I/D/√	√		Based on empirical reliability field failure data on similar products.
4.	Translation	√	√		Translates a reliability prediction based on an empirical model.
5.	Empirical	√	√		Relies on observed failure data to quantify part-level empirical model variables.
6.	Physics of Failure	√	√	√	Models each failure mechanism for each component individually component reliability is determined by p.d.f.

Test or Field Data Predictions

Reliability predictions for modified or off the shelf products often make use of existing equipment (or assembly) designs or designs adopted to a particular application. Table 9.2 summarises the data needed for reliability based on test or field data.

Assuming an exponential distribution, the specific prediction for the product is simply a matter of determining operating hours and types of failures expected. Failure rate can be found as:

$$\text{Failure rate} = \frac{\text{Number of Failures}}{\text{Operating Time}}$$

With this information reliability results predicted will be accurate with uncertainty of estimate. Disadvantage is to procure the accurate field data.

Table 9.2: Reliability Data

Information required	Product Field Data	Product Test Data	Piece Part Data
Data collection time period	x	x	x
Number of operating hrs. per product	x	x	
Number of part hours			x
Total number of observed maintenance actions	x		
Number of no defect found maintenance actions	x		
Number of induced maintenance actions	x		
Number of observed failures		x	x
Number of relevant failures		x	x
Number of non-relevant failures		x	x

System Reliability Assessment Prediction

This approach takes place in two successive stages (i) System pre-build Process (ii) System post-build Process. First case reliability assessment methods are used with grading factors with the operating profile and the initial reliability prediction. In case of second step the best estimate with system test and process data using Bayesian statistical method.

Similar Item/Circuit Prediction

This method starts with the collection of past experience data on similar products. The data is evaluated for form, fit and function compatibility with the new product. If the new product is an item that is undergoing a minor enhancement, the collected data will provide a good basis for comparison to the new product. Small differences in operating environment or conditions can be accounted for by using translation methods based on previous experiences. If a product does not have direct similar item, then lower level similar circuits can be compared. In this case data for components or circuits collected and a product reliability value is calculated. The general expression is:

$$R_p = R_1 \cdot R_2 \cdot \dots \cdot R_n \quad \dots(9.4)$$

Where R_p — Product reliability
 $R_1 \cdot R_2 \cdot \dots \cdot R_n$ — Component reliability.

The advantage of using this method is that it is quickest way to estimate a new product's reliability and is applicable when there is limited design information. The disadvantage is a new product may be sufficiently different, resulting in inaccurate prediction.

Prediction by Operational Translation

It is well known that field (operational) reliability differs from the inherent or predicted reliability because empirical models only assess inherent component reliability, and the reliability of systems in field operation includes all failure causes, including induced failures, problems resulting from inadequate design, system integration problems, manufacturing defects etc. Since, the intent is to assess total system reliability including all factors that can effect system reliability a translation may be necessary to convert the empirical predicted failure rate to expected field failure rate.

The advantage of this technique are the ease of use and application of environmental factors for harsh conditions. The disadvantage is the lack of up-to-date empirical data and the limited number of translation scenarios.

Empirical Model Prediction Techniques

Are those that have been developed from historical reliability data basis. This data can be either from fielded applications or from laboratory tests. As a result of the manner in which these models are developed, their relevance is a function of the data used to drive them. Therefore, Reliability prediction will vary as a function of the specific empirical prediction methodology used, because the empirical data on which they are based was collected from different sources and environments.

In this case part count prediction and detailed stress prediction are used for prediction of reliability. The major influencing factors for electronic components are given in the Table 9.3.

Table. 9.3: Major influencing Factors

Device type	Influence factor
Integrated circuit	Temperature, package type, supply voltage
Semiconductors	Temperature, power dissipation, breakdown voltage material
Resistors	Temperature, power dissipation, type
Capacitors	Temperature, voltage, type
Inductive devices	Temperature, current, voltage, insulation
Switches and relays	Current, contact power, type of activation

The Fig. 9.2 shows that failure rate increases with temperature rise or as the applied stress (voltage) increase.

Physics-of-Failure Prediction

The objective, this method is to determine or predict when a specific end-of-life failure mechanism will occur for an individual component in a specific application. A physics-of-failure prediction looks at each individual failure mechanism such as electro migration, solder joint cracking, die bond adhesion, etc. to estimate the probability of component wearout within the useful life of the product. This analysis requires detailed knowledge of all material characteristics, geometries, and environmental conditions. Specific models, for each failure mechanisms are available.

The advantage of this approach is that accurate predictions using known failure mechanism can be performed to determine the wearout function. The disadvantage is that this method

requires access to component manufacturer's material, process and design data. In addition the actual calculations and analysis are complicated activities requiring knowledge of materials, processes, and failure mechanisms.

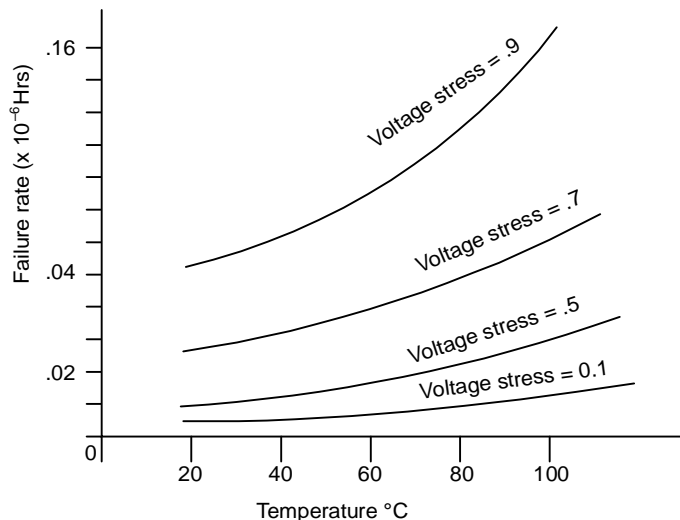

Figure 9.2: Trimmer Ceramic capacitor

Confidence Levels of Predictions

In general a reliability prediction cannot be linked to a specific confidence interval, as might be done in demonstration test or when measuring failure rates from field returns. The primary reasons for this inability to define a confidence interval are:

- Reliability prediction models, including, PRISM, FIDES Guide and MIL-HDBK-217 are typically based on part data gathered from a variety of sources. Complete models are not usually developed from a single data source.
- In some cases, while it might be possible to calculate a confidence interval for some basic part failure rate, it is practically impossible to predict the confidence interval for all the modifying parameters, even when they are based upon well known and widely used physical acceleration laws, e.g. Arrhenius or the Inverse Power law.
- In addition to the variability associated with developing the models, there is human variability involved in making prediction assumptions, analyzing the data, counting of field failures, and even in the failure definitions themselves.

Thus, because of fragmented nature of the part and environmental data and the fact that it is usually necessary to interpolate or extrapolate from available data when developing new models, no statistical confidence intervals should be associated with the overall model results for any given prediction.

Followings are some of the important points which should be considered during reliability prediction and assessment.

- Year of manufacture can have a significant impact due to the momentous growth in reliability resulting from improvements in the manufacture processes of many electronic parts.
- Process grading accounts for factors, other than part failures, that impact system reliability.

- Predecessor analysis is a means of predicting field failure rate of a newer model assembly or system based on a comparison of the old and new predictions and field experience of the earlier model.
- Bayesian analysis allows for faster refinement of the failure rate based upon other empirical data.

TOOL AND TECHNIQUES

There are a tremendous of design principles that can be utilized to promote system/equipment reliability. These can include the following: Part Selection, Control and Derating. Since, an electronic system is made up of discrete components, the selection and quality of these components is of crucial importance. Choosing the right type of part for the right job can mean the difference between reliability and unreliability. Part selection involves decision such as TTL vs ECL, the use of plastic encapsulated devices and surface mount vs, through hole technologies. Furthermore, the performance of critical parts should meet the industry guidelines.

Reliable Circuit Design

As a general rule, simpler designs will be more reliable. Thus, there should be a push for simplicity throughout all phases of the design process. The necessity of all parts should be questioned and design simplifications should be employed where available and possible. This can be through circuit design simplifications or by simply using fewer parts. Also, the use of standard components and circuits is always recommended (where a component could be as complex as microprocessor). Reliable circuit design also entails a parameter degradation analysis. Since, Component parameters are known to drift overtime, one must ensure that different tolerances can not combine in such a way that will degrade system functionality.

It is well known and understood that the complex system/equipment has a problem of fault detection and thus, it consumes extra time to repair/replace the parts.

Redundancy

Redundancy is the use of extra component depending upon the criticality of the system. It is seen that use of n elements or subsystems in parallel increases the reliability of the overall system. These systems involve active redundancy where normally all of the elements/ subsystems are in continuous operation. When system has to run in case of failure of the main equipment/system this situation calls for standby redundancy. Here only one unit is operating at a time, other units are shutdown and only are brought into operation when the operating unit fails.

Figure 9.3 shows general standby system consisting of n identical units, each with failure rate λ and a switching system S . Normally only unit 1 is operating and the others are shutdown. If unit 1 fails then unit 2 is switched in, if unit 2 fails unit 3 is switched in, and so on until unit n is switched in.

Assuming that switching system has perfect reliability ($R_s = 1$) then the reliability of the stand by system can be given as:

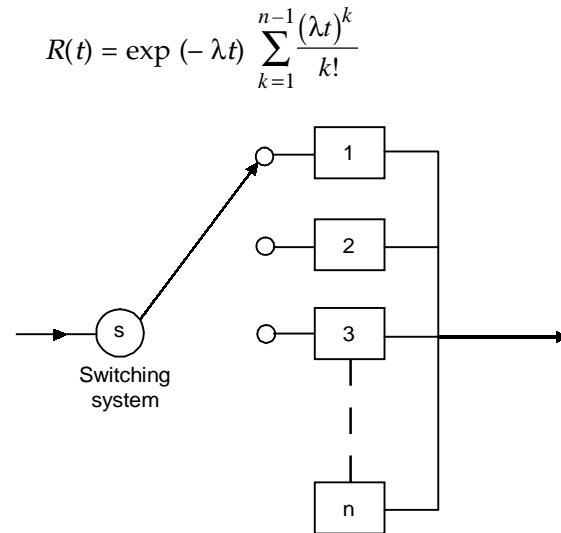

Fig. 9.3: Standby system

Putting different values of n i.e., 1, 2, 3... n the total system reliability can be calculated, which is found to improve with the number of standby systems.

Design for Environment

It is seen in actual practice that environmental factors have direct wearing on the reliability. Therefore, designing for a particular environment, one can improve the reliability of the system/equipment. The factors which are of the concern of the design engineer include, extreme temperatures, humidity, salt spray, moisture, dust, sand, gravel, vibration and shock EMI etc.

It should be noted that when two of these factors occur together the resulting failure rates may be especially high. For example, the presence of salt in an atmosphere which is also very humid will cause corrosion. Table 9.3 below compares the failure rates of two given types of instrument i.e., control valves and differential pressure transmitters, when used with 'clean' and dirty fluids at a chemical works. The 'clean' fluid is a single phase, non-corrosive gas or liquid with no impurities present, the 'dirty' fluid has either solid particles or sludge present or may polymerize or corrode.

Environmental correction factor Π_E can have value of 1, 2, 3 or 4; the highest value corresponds to the worst environment. The observed failure rates can be regarded as the product of base failure rate λ_B and an environmental correction factor λ_E , i.e.

$$\lambda_{OBS} = \lambda_B \times \lambda_E \quad \dots(9.5)$$

IMPACT OF WORKING ENVIRONMENT

As discussed above the working environment of a system/ equipment has direct influence on the reliability of the equipment. The Table 9.3 shows that the number failures increase as a result of change in environment. Sometimes even the material of the components/parts has to be changed, because 'dirty' fluids either have solid particles or sludge present or may

polymerize or corrode the in contact parts. The Table 9.4 given below shows that the instruments which are in contact with process fluid have high failure rates as compared with those which are not in contact with process fluid.

Table 9.3: Environment impact

<i>Instrument</i>	<i>No. at risk</i>	<i>No. of faults</i>	<i>Failure rate faults/yr.</i>
Control valve			
Clean fluids	214	17	0.17
Dirty fluids	167	71	0.89
Differential Transmitter			
Clean fluids	27	5	0.39
Dirty fluids	90	82	1.91

Table 9.4: Failure rates of instruments

<i>Items</i>	<i>No. at risk</i>	<i>No. of faults</i>	<i>Failure rate (faults/yr.)</i>
Instruments in contact with process fluid	2285	1252	1.15
Instruments not in contact with process fluid	2179	317	0.31

For electronic equipments/systems, therefore, the clean and non-moistured environment is essential to improve their reliability and longitibility of the life. Since, the parts/components are very sensitive in nature because the presence of even dust particle can yield wrong reading/results which frequently observed during its use. The temperature control is also essential for integrated systems due to their complexity requirements, as high temperatures can cause thermal stresses, this increases the failure rates.

The other factor which affects component failure rates is the complexity and maturity of the manufacturing process. Experimental data show that component failure rate decreases as a manufacturing process matures and component imperfections are removed.

QUESTIONS

1. Explain how reliability prediction can help in improving the reliability of electronic systems?
2. Discuss, briefly the reliability analysis to carried out on electronic components.
3. Reliability block diagram is a mandatory component of reliability assessment. Explain with example.
4. How reliability prediction can be made for electronic components? Explain.
5. Discuss various techniques used for the prediction of reliability for electronic components.
6. Explain tools and techniques employed for the prediction of reliability.
7. How does the environment of equipment/system affects the working? Explain.

Reliability Assessment and Testing

INTRODUCTION

The systems comprise of number of components placed either in series or parallel for performing a specific task without interruptions for a stipulated time. For this purpose maintenance activities are to be accelerated to avoid unforeseen breakdowns. The reliability assessment here means to know the time period for which the system will work without failures/breakdowns. By carrying out case studies on the past performances of the equipment, it is possible to predict its failure free time periods. For this purpose, certain past data will be required for the equipment under investigation. The authenticity and accuracy of the above information will yield correct results, which will be close to real life situation. There are a number of methods available to assess the performance of equipment/system for intended time period. The first information required will be the failure data of the components/units of an equipment/system.

To meet out the design and reliability specifications it is desired to test the finished product so that the failure rate remains within the pre-specified lower and upper limits. The problem of testing is more significant where the life time of the component is very long normally in case of electronic items. In case of such components the under actual usage condition would require too much test time and excessively large sample size. Accelerated test are therefore used for the primary reliability-related factors of applied voltage, temperature and humidity. In addition, statistical sampling is used, taking into account the similarities between products in process and design, so as to minimize the number of test samples.

Reliability testing should be considered as a part of integrated test programs which include the following:

- 1. Statistical testing:** To optimize the design of the product and the manufacturing processes.
- 2. Functional testing:** It is to confirm that the design meets the performance requirements.
- 3. Environmental testing:** To ensure that the designed product can work successfully under specified conditions.
- 4. Reliability testing:** To ensure that the product renders services for the specified period of time without undesirable problems.
- 5. Safety testing:** To ensure all safety aspects have taken care off.

Reliability is a function of time and variability therefore, the tests should be carried out for a long period of time, to ensure failure distributions, particularly wear out failures. It is observed that if the tests are carried out properly will bring down the total development cost and reduction in overall maintenance functions.

RELIABILITY PREDICTION

The reliability requirements suggest that the estimate or prediction of reliability before the actual production of equipment/system should be carried out. Prediction of reliability is a continuous process to be carried out at various levels of design starting from the design of product until it is put in use. Based on the past history of equipment it is easy to predict the reliability which is basically dependent on failure rate distribution and the working conditions of the product. It can be on Exponential and Weibull distributions, since failures follow these distributions very closely for most of products.

The following steps can be used to predict the reliability of the equipment/systems in use.

(i) **Definition of system:** Any equipment/product is made up of sub-systems/components, units which must be specified for their functional configurations and boundaries. This information will help to make the functional block diagrams of the products/equipment to assess the reliability. The failure of components in a block will make system failure depending upon its configuration.

(ii) **Block diagram:** It is similar to functional block diagram with the difference, to identification of reliability influencing factors. This shows the sequence of operations of components with their importance on reliability parameters. A complex system which is made up of thousands of components, however, units which are not essential to successful operation need not be included such as decorative accessories as their failure do not affect system reliability. Redundant paths and alternative parts/components are clearly specified in the diagram.

(iii) **Identification of relevant factors to reliability:** Here emphasis should be laid on critical parts/components which are crucial for reliability prediction. Factors which are responsible for the failure of parts should be examined carefully and correctly. Adjustment of parts/components may play an important role to improve reliability which must be cared for.

(iv) **Selection of reliability data:** The failure rate data of all critical parts with respect to time and environmental conditions must be examined properly. Collection of such data is difficult task at initial stage particularly for a new product. However, this information can be collected from field performance studies, life test, inspection tests and any other sources.

(v) **Determination of reliability:** Using above information the reliability of each block component/part can be calculated, which can be used to determine the overall reliability of the product/system. In case of non-availability of relevant reliability data accurate estimates based on past experiences of similar components can be made. In such cases simulation models can also be applied.

(vi) **Application of predicted results:** This helps to predict the successful life of product but also indicates the weak areas, the extent of improvements required and alternative methods which can be used to improve the reliability functions.

THE RELIABILITY DATA

The starting point in reliability assessment is the evaluation or estimation of reliability of component or unit that can only be done with the help of failure data of the component. The failure of a component means that at a particular instant it is not performing its assigned task. Under certain conditions the items/components can be repaired and reused, whereas some

components can only be replaced, as no repair is possible. The inaccuracy in reliability data may not yield the correct results even after using the correct model. This inaccuracy may arise in obtaining the data or in their use. The availability of data in the required form is therefore essential otherwise their synthesis will be required.

The reliability data can be obtained from field experience and sample testing. Field experience is meant for the monitoring and recording of the elements reliability characteristics over a period of practical usage. Sample testing on the other hand, refers to an experiment deliberately set up to record the required information from a representative sample. The obtained failure data must be tested within the specified confidence limits to make the generalized representation, since the data pertain to a specific component unit. This will give an indication about the distribution of the failure data, which have to be collected.

RELIABILITY MODELS APPLICATION

Depending upon the configuration of parts/components different reliability models can be used to evaluate the reliability of equipment/system. A particular model can suit only a particular layout of components in an equipment or system. Based on the layout of the components, the reliability of the equipment/system can attain different values. In case of series layout of parts, the system will fail by failure of any of its component/part and its reliability will fall to zero whereas, in case of parallel layout, system may remain active even after failure of its some of the components/parts. But from design point of view, it is always not possible to select any particular layout of components/parts. However, efforts can be made during design phase to take care of component layout also, which will directly affect, the reliability of the equipment.

Though various models for reliability evaluation are available, but its application will largely depend upon the configuration of the components. In case of series model, the reliability of each components/parts will play an important role, since equipment reliability will be the product of the reliabilities of each component. However, in case of parallel configuration, it will be the summation of reliability of each component/part.

It is noticed that when redundant components/parts are used with any equipment its reliability improves significantly though the cost of such systems would be high.

RELIABILITY AUDIT

Before any product is put into the market must be tested over a period of time to measure its achieved reliability with due considerations of the environmental conditions. But these methods are not being practiced by many of the organizations particularly in India and therefore, their products don't compete at international market. The need for reliability audit is more pertinent under such conditions to promote the sale of the product/equipment. For every product national/international standards are set by the quality control departments and the same should be examined through internal or external audit teams. Even internal audit is a good practice if followed ignoring the external audit which is required for the products to be marketed internationally.

The concept of straight-forward warranty is being introduced to attract the customers in almost all electrical and electronic products. This can be further supplemented by the concept of contract maintenance or after sales service.

ELECTRICAL STRESS

In addition to temperature, some electrical quantities such as voltage, current or power effects are also the part of increased failure rate. In order to lengthen the useful life of the operation of parts is recommended not with maximum acceptable ratings but with reduced stress conditions. Such rating will improve the reliability and minimize the failure rate.

It is seen that voltage factor increases with rise in voltage. The failure rate of some of the IC's is proportional to the factor. With power supply of 15 V a, CMOS IC may fail 10 times as much as if it is operated at 5 V which clearly shows that how variation voltage affects the system performance.

A serious problem is the electrostatic discharge (ESD) damage which is termed as the new contaminant of the age of microelectronics. It occurs in both MOS and bipolar devices. It can cause an immediate or delayed damage to circuits. In many cases no damage can be measured until months have passed and the equipment has failed in the field. A voltage, as low as 100 V, is reported to be capable of damaging semiconductor devices. Overstress is assessed to have occurred by ESD. This happens in spite of input protective devices (e.g. diodes) on the IC to prevent the discharge from supporting the gate oxide. The other provisions to protect against ESD are:

- A proper floor finish,
- Grounding of furniture,
- Application of special sprays and
- Control of humidity in the work areas.

The other kind of damage is caused by current stress. The main effect is electro migration of metallization patterns. The rate of migration is proportional to current density and failure rate increases approximately with the square of current density.

RELIABILITY PARAMETER ESTIMATION

If the failure distribution of relevant associated parameters are known then the parameters required for the reliability can be obtained. When the population of the desired data is large sampling can be done randomly giving equal chance of selection of each item in the population. For finite size of population selection of samples can be done with replacement so that each selection process is unaffected by the earlier selection. Tests on samples are conducted to determine the failure rate, or mean time to failure or similar characteristics appropriate to the population.

In reliability analysis the parameters of the interest are reliability function, hazard rate, failure density, mean time to failure, mean time between failure, reliability life etc. All these are associated with appropriate probabilities for the given function. If the failure distribution function governing a given population is known, then the required reliability characteristics can be obtained. Various distributions and models have been discussed in previous chapters. The two important quantities generally obtained from any distribution function are mean and variance, which can be expressed in terms of parameters for any distribution.

RELIABILITY SYNTHESIS

For the evaluation of system reliability collection of appropriate reliability parameters is essential. But the collection of relevant information is difficult at all levels. If the data are not available at the system level, but are available at a lower level, through systems synthesis, the same can be used to complete the system. The reliability model, which combines both discrete change of state and continuous variations in performance, needs to be examined for methods of synthesis. Here for the purpose of simplicity, the two-element system can be considered which will have four possible states. In general, if the system can be represented by just two states than sub-states act of the four will combine for success and the remaining (4- n) will combine for failure. Since, the two-element system can take on a number of forms depending upon the logical arrangements, it is required to consider them separately. Where both elements are required for system success, can be termed as 'non-redundant arrangement'. When only one element is required for the system, system will be called as redundant. The non-redundant system can be considered as series reliability model, whereas redundant system will fall in the category of parallel reliability model.

In the same manner, the complex systems can be reduced to standard form during the reliability parameters of interest.

LIFE TESTING REQUIREMENTS

During production, devices are strictly controlled and screened to eliminate those with a potential for failure. In addition, inspections of product characteristics and periodic reliability monitoring ensure that the product quality level remains high. After product selection tests are carried out in conformance with the test standards.

Information collected at all stages of product development, from design to production, as well as from reliability testing as described above, is used to maintain and improve devices and to provide our customers with the safest and most reliable products possible.

Before testing there are number of points that must be considered when determining tests, stress conditions and sample size.

In order to satisfy reliability test objectives as discussed above, the following must be considered.

1. Where the product is to be used?
2. What kind of environment and operating conditions of the device are used?
3. What are the expected failure modes and mechanisms of the device, and what type of accelerated stress testing is appropriate?
4. What reliability standards are required for the product in the market?
5. What is the expected life span of the product?
6. How does the product rate in terms of motivation and importance?

Following are the accelerated stresses which can be applied on the products depending upon its type, for example on electronic items:

- Temperature
- Temperature and humidity
- Applied voltage

- Temperature cycling
- Current density
- Vibration
- Shock
- Constant acceleration
- Impact etc.

An important consideration in reliability testing is that test results must contribute to the evaluation and improvement of product reliability. It is therefore important to apply reliability testing consistently and repeatedly, to perform detailed failure analysis, and to carry all results back to the device design and processing stages.

SAMPLE SIZE SELECTION

Generally, all the items produced should pass the quality and reliability tests before they are used in actual working conditions. When the products are manufactured in lots or in batches of a given number it is difficult and impossible to test all the items particularly when the lot size is large. A practical solution to this problem can be to take random samples from the lot and test each of them. With this procedure a risk factor either for customer or for producer is involved. When unsatisfactory lot is passed it will be called as customer's risk. Similarly, when a good lot is rejected it is the producer's risk. The various sampling schemes used include the following:

1. **Single Sampling Scheme:** Here sample of n items from a lot size of N are tested.

Let c be the number of items to be defective. Then accept the lot if number of defective is less than c otherwise reject the lot.

The lot tolerance per cent defective (LTPD) sampling is based on the customer's risk and acceptable level (AQL) is based on the producer's risk.

2. **Double Sampling Scheme:** Single sampling scheme can result in sudden death outcome where whole lot may be rejected on the evidence of a single sample. In a double sampling scheme, a second is taken in order to reinforce the evidence of first sample.

Here we test a sample of n_1 items from a lot size of N .

If the number of defects less than c_1 – accept the lot

If number of defects greater than c_2 – reject the lot

If c_1 less or equal number of defects less or equal c_2 – take another sample

Then treat the operation as single sampling with sample size $n_1 + n_2$ and acceptance value c_3 .

The total number of item tested will be less than in a statistically equivalent single scheme.

3. **Multiple and Sequential Sampling Schemes:** The principle of double sampling can be extended to multiple sampling; here a large number of small samples, all of the same size n , are taken until a decision either to accept or reject the entire lot is reached. The advantage of multiple sampling is that the total number of items tested will be less than in statistically equivalent double scheme; the disadvantage is that it is more complex.

RELIABILITY TEST STANDARDS

Various industries and associations establish their own reliability standards depending upon the working environment of the equipment/system. Some of the standards for electronic components are listed below:

1. *Electronic Industries Association of Japan (EIAJ)*: It has listed a few standards for reliability testing of semiconductors which specify Environment and Durability testing methods under various conditions.
2. *U.S. Military Specifications and Standards (MIL)*: These standards are used for reliability testing of Electronic and Electrical Components and parts, such as semiconductor devices and microelectronics.
3. *International Electro Technical Commission (IEC)*: These standards specify Environmental testing part-1 and 2 with mechanical and climatic test methods for semiconductor devices.
4. *Japanese Industrial Standards (JIS)*: These standards specify environmental test methods for electricity and electronics.
5. *Joint Electron Devices Engineering Council (JEDEC)*: It incorporates various test methods.
6. *Capital Electronic Component Committee (CECC)*: These standards include general specification monolithic integrated circuits and general specification digital monolithic integrated circuits for testing electrical and electronic components.

TEST METHODS AND PLANNING

The method of reliability testing can be classified in two categories.

- (i) *Test elements group (TEG)*— in which a special set of devices are created for the purpose of analyzing each failure mechanism, and product evaluation, whereby overall product evaluation are performed. TEG evaluation targets basic failure mechanism. A set of devices is manufactured especially for this purpose. This method allows detailed evaluation and analysis of failure mechanism. It is very effective for quantifying limits and allows use of accelerated conditions.
- (ii) *Design approval testing (DAT)*— which eliminates failure mechanism that affect reliability in products.

Product reliability testing should approximate to the actual field environment and must always be repeatable. For this reason tests should be performed according to approved standards.

Similarly, mechanical tests such as vibration, shock, constant acceleration etc. can be carried out at normal working conditions.

Accelerated Lifetime Tests

With ever increasing requirements of components reliability, the need to evaluate product lifetimes and failure rates is now greater than ever. Reliability tests simulate actual conditions of the products. Testing under normal/actual working conditions would take exceedingly long time. Therefore, stresses beyond absolute maximum rating are applied to the devices to accelerate the failures. In this way, device lifetime and failure rates can be determined, failure

mechanism can be analysed. This type tests are called as accelerated life tests. Such tests are also used to force device degradation in order to determine a device's wear out period.

In general, if the degradation is fairly simple, life times and failure rates can be estimated relatively accurately using accelerated testing. Complicated failure mechanisms are difficult to simulate. It is important to select test conditions such that failure mechanisms are relatively constant, few and simple.

Table 10.1: Product Reliability Test Method Example-Semiconductor Device

Type	Test	Description and conditions of test
S T E M I T E F I L	Steady state operation	Apply electrical stress (voltage, current) and high temperature for Extended period of time
	High temperature, high humidity baising	Apply electrical stress (voltage, current) high temperature and moisture for extended time period
	High temperature storage	Apply high temperature for extended period of time
	Low temperature storage	Apply low temperature for extended time period
	High temperature, high humidity storage	Apply high temperature, high humidity conditions for extended period of time

Constant Stress and Step Stress

The accelerated tests are of two types, constant stress and step stress. In a constant stress test, the time dependent failure distribution of a sample subjected to constant stress at several stress levels is observed. In a step test, stress is applied to a test sample gradually in stepped increments, and the step which failure occurs is observed.

Temperature

Accelerated life testing is closely related to the physics. The physical and chemical reactions inherent in device degradation are often treated as examples of chemical kinetics. Chemical kinetics is a basic chemical reaction model that describes the temperature dependence of failures. It is seen that the temperature dependence increases as the activation energy increases.

TEMPERATURE AND HUMIDITY

Moisture Resistance Tests

The reliability of some of components depends largely on the moisture contents during their working for example, semiconductors. Various types of moisture resistance evaluation tests are developed in order to evaluate these devices quickly.

While testing the devices sometimes they are subjected to humid atmosphere or the moisture is allowed to penetrate the device.

Voltage

Aluminium corrosion due to humidity and characteristic degradation due to mobile ions are accelerated by voltage. In these cases, voltage is applied continuously to the oxide film and breakdown occurs over time, even if the electric field in oxide film is below the breakdown limit.

Temperature Cycling

Temperature cycle thermal shock tests verify reliability against repeated thermal stress from external or internal heat sources. In the test the device is subjected to low and high temperatures repeatedly. Failure modes such as bonding opens, passivation cracks, package cracks, chip cracks and characteristic degradation (due to piezo effects) are checked. In the temperature cycle test the device is usually subjected to it's high and low temperature limits repeatedly. In some cases these limits are exceeded to achieve even greater acceleration. However, it should be noted that, because of the different materials used, different areas of device will have different physical characteristics and will produce varying test results. Therefore, the behaviour of the device in the field may not match the test results.

FAILURE RATE ESTIMATION

It is important from the point of view reliability and safety to estimate failure rates for the components used in different equipment.

Failure rates are estimated by calculating an acceleration coefficient based on an acceleration life test or by gathering failure rate statistics from products used in field.

Estimation Using Accelerated Life Tests

With rapid technological change in industries, accelerated life testing has become increasing important as a practical and economical means of evaluating reliability. This is essential to bring the new products to the market quickly. Here, it is described how failure rates can be estimated by the use of accelerated life test in the field.

When estimating failure rates from test data in the field, the actual number of failures is often very small or, in many cases, zero. In such cases, the failure rate must be estimated on a certain confidence level. When the failure pattern follows exponential distribution the following relationship can be used.

$$\text{Failure rate } \lambda = r/T$$

where, r = number of failures; T = total components hours

RELIABILITY TESTS

The reliability tests are required to show that the finished products meet the reliability specifications defined during design stage. The target failure rate within the limits under all specified environmental conditions must be verified. A full reliability test may comprise of basic three activities and include:

(i) **Failure rate:** Under specified conditions of temperature range, stress and environmental conditions the failures of the product must be measured on individual items or on random samples. The test may involve, testing at different level of temperature, humidity, mechanical vibration, mechanical shock, operating voltage and salinity.

(ii) **Burn-in:** The above cited conditions of testing are made more severe than the defined specifications. This is done to accelerate the failure of weak or defective components so that they fail during test. The aim here is to eliminate or minimize the early failure region as shown in bath tub curve, so that the useful life of the product is extended. This is normally done for electrical and electronic components at high level of temperature humidity and voltage.

(iii) **Screening:** This includes visual inspection constant acceleration and measurement of electrical parameters of electronic components and assemblies.

IMPLEMENTATION OF RELIABILITY TESTING

Design Approval Test Procedure

Reliability tests on the devices are performed in research and development phase and in full production phase. During research and development, reliability tests are used to evaluate the quality of design, the material and processes. During full production they are used as design approval tests (DATs) and for periodic reliability monitoring.

During prototyping of the product the components are divided into families according to their performance. Reliability testing is performed on a representative product from each family. Tests for early failure rate, (EFR), long term life or random failure rate (IFR), time to wear out and resistance to environment are performed.

Reliability Monitoring During Full Production

Products passing DAT are given an initial quality assurance inspection before shipping. In addition periodic monitoring is performed to verify the reliability levels of shipped products. In the initial quality assurance the basic features and appearance are checked. The objectives are to verify the product quality of each product lot and to assure the quality of the shipped products.

Periodic reliability monitoring involves life and environment tests performed on groups of products classified by process and package family. Reliability is continuously monitored, failure rates are analyzed and results are fed back to the manufacturing process. In addition, data are accumulated allowing reliability to be further improved.

For any type of reliability testing, test set-up are designed to create actual working conditions. The loading range of the products plays an important role to indicate the failure mode.

Data Reporting System

Reliability testing is performed on product families during product development and periodically thereafter to monitor reliability. The results are given to the customer at three-month intervals in the form of reliability reports—Referred as Quarterly reports—which contain the results of the tests and the results of initial quality assurance inspection for each family.

Data Reduction and Analysis

For mass production system the quantity of the data can be very large, which cannot be used directly for reliability evaluation, therefore selection of a sample size is needed. This can be done through data reduction and analysis

QUESTIONS

1. Explain, why reliability testing required.
2. How is sample size for reliability testing selected?
3. Describe various methods used for reliability testing. Why is their planning required?
4. Discuss various reliability test standards used in practice.
5. How failure rate can be estimated? Explain.
6. Enlist the steps required for the implementation of reliability testing.
7. How does data reduction and analysis helps in reliability testing?
8. Discuss the need of reliability assessment.
9. Discuss reliability synthesis and highlight its importance.

**This page
intentionally left
blank**

Quality and Reliability

INTRODUCTION

The quality of a product/system can be defined as its ability to ensure complete customer satisfaction in totality, which may include all aspects such as comfort, appearance etc. For example, in case of automobiles such parameters are given due weight-age. However, the quality of engineering products can be measured in terms of its characteristics that contribute overall performance, which satisfies a customer/user's requirements. These are termed as performance characteristics, which are of three types i.e. continuous, discrete and binary.

Continuous characteristics can take any value within a given range, for example, fuel consumption, which can take any value between 10 and 60 km per litre. The discrete characteristics are related with appearance, comfort, etc. and cannot be quantified which are subjective in nature. On the other hand, binary characteristics yield result in terms of two conditions. The said objective is either acceptable or not i.e. in terms of 0 and 1. In general the products can be specified using continuous performance characteristics. Their values can be established by independent measurement of performance identifying characteristics.

All engineering products are subjected to random effects in the components, which make up the product. The physical dimensions of any two products cannot be exactly the same. However, environment plays an important role. These random effects can be regarded as random inputs to the product, which result in corresponding random variations in the output, of continuous performance characteristics of the product. This random variable may be the source of dissatisfaction to the customer. For the very reason the specification limits are specified for almost all products.

QUALITY CONTROL OF PRODUCTS

Visualizing the random variations in product characteristics, it is required to adopt the quality control of the product. Some statistical methods are employed using upper and lower specification limits to monitor the quality. Here concept of mean and standard deviation is used to either accept or reject a lot, which is being tested. The whole exercise is termed as statistical quality control (SQC). There are two main sources, which are responsible for any variations in product characteristics, which include the following.

- (a) The variability brought-in the components due to design defects and due to poor quality of the materials.
- (b) The variability of the production process may also affect the quality of the products i.e. use of different machine for the same job or use of different processes for the same product.

SQC techniques can be used to identify and limit above both sources of variability. When this technique is applied to any process, it is termed as statistical process control (SPC). Here, line measurements of product performance characteristics are made and compared with the specification limits. This will not only indicate percentage of error, off-specification of product but should also identify the sources of variability in the process, which can be monitored and minimized after being located.

PRINCIPLES OF QUALITY

Quality is associated with the entire product, which are being manufactured by any process. The cost of the product is directly proportional to its quality. For ultimate satisfaction of the users/customers, the concept of quality has to start from the inception of the product. If the raw material used does not possess good quality, the final product cannot meet the required quality standards. Even, if the quality of the raw material is satisfactory, the process of manufacture will also contribute for the products quality. To check the quality of the products standards are set by the government and the products, which pass through the tests conducted by such organization, acquire the standard make, which ultimately helps in selling the product. For this purpose Government of India, has established the Indian standard. Therefore, a particular product dominates the market due to its quality only.

The quality of some products cannot be measured in terms of comfort it provides to the users. For example, the quality of a room in a hotel can be judged by the facilities and the comfort derived by the user. For the engineering product, the quality can be quantified i.e. it can be measured. The quality of an automobile can be expressed in terms of performance characteristics i.e. mileage it gives besides the comfort it provides to the users.

QUALITY CONTROL

For measurement of quality, predefined standards are set with upper and lower limits. If a product's performance falls within the specified limits, it is accepted, otherwise, it is rejected. Depending upon the products, inspection has to be carried out either on each item or on a sample drawn from the lot. When sample inspection is carried out, the lot is either accepted or rejected depending upon its meeting out the quality specification within the said standard limits. This system is normally followed for mass production, since inspection is not possible on each item/product. Whereas, in case small number of products, the inspection has to be carried on all items individually, for its acceptance or rejection.

For the purpose of continuous performance evaluation of different parameters of a product/equipment, is defined, with target values. However, all engineering products are subject to random effects in the components, (which make up the product), in the manufacturing process and in the environment where a particular equipment/product is to be used. The variations take place around the target values with upper and lower limits, which are called as specification limits.

To know how the actual random variations in a given performance characteristic say x , for a given product, compare with the target value x_T , within the given upper and lower specification limits. A statistical analysis for these variations is required and involves calculation of mean standard deviation and probability density function of the variations.

To carry out the exercise assume that N samples have been taken from the total population of values of x . These are given as x_i , where $i = 1, 2, \dots, N$

The mean and standard deviation can be expressed as given below:

$$\bar{x} = \frac{1}{N} \sum_{i=1}^{i=N} x_i \quad \dots(11.1)$$

$$S = \sqrt{\frac{1}{N} \sum_{i=1}^{i=N} (x_i - \bar{x})^2} \quad \dots(11.2)$$

The values of mean and standard deviation specify the center and the spread in the sample values but do not give information about the shape of the variation, which may have any profile. However, this information can be obtained by probability and probability density functions. The probability can be expressed as the ratio of number of occurrence of the event to the total number of trials, when these are made independently. Whereas probability density function can be expressed as:

$$p(x) = \lim_{\delta x \rightarrow 0} p_j$$

where, J specifies, the section for $j = 1, 2, \dots, m$ and δx is the width of each section.

After comparing the statistical distribution of each characteristic with given specification limits, it is to be decided to accept or reject the product.

THE CONCEPT OF TOTAL QUALITY

The failure of a product/system either causes direct financial loss or inconvenience to the customers/users. Examples could be late running of public transport system or power failure in a market complex. In engineering context, a defective machine selling may lead to defective components and rework of the same with additional costs and time delay. Since, parts may get damaged during transportation due to incorrect packaging.

Under all circumstances poor quality may be defined as a failure of product or service to perform intended operation successfully, which ultimately does not satisfy the customers/users.

Taguchi suggested that the deviation of a product from an optimum performance might be described by a "quality loss function" which can be selected with monetary value. The objective of an organization should be to minimize the quality loss function of its product/service. Under total quality function all parts of the organization are responsible for its success/failure. The policy of the organization should be of continuous improvement of its products/services.

The key principles of total quality are following:

- Adopt policy of continuous improvement of all areas, including training in the newer technical fields.
- Reduce number of suppliers, and try to involve them in continuous improvement also.
- Provide on-line techniques to identify problems and their solutions using statistical methods.

- Make use of multi-disciplinary teams, with open and congenial environment for effective participation of all working groups.

The following quality engineering techniques can be applied to improve the quality of product/service:

- (i) Quality function deployment (QFD) is a matrix technique for identifying product/process design requirements and efforts required in meeting these requirements.
- (ii) Design for manufacture and assembly (DFM/DFA). This describes methods that assist in designing a product for ease of manufacture and assembly.
- (iii) Failure mode and effect analysis (FMEA) is a systematic approach for identifying possible modes of failures of a product or process and their consequences on such failures.
- (iv) Taguchi Methods is a statistical method to evaluate quality loss function in order to minimize variation in design performance.
- (v) *Poke Yoke*: It is the term used to describe proof devices within a process to prevent defective products being produced. For example, the shape of a part is such that it can be fitted in only way to avoid confusion to the technician.
- (vi) Process capability studies involve about correct information in connection with required tolerances for a particular process.
- (vii) *Simulation*: This can be used where past data/information on the subject matter is not avoidable.
- (viii) *Validation and testing*: This involves a number of tests methods for verifying that a product design performs as expected.
- (ix) Besides above all, problems solving techniques can be used for identifying of a problem and its solution.

PROCESS CONTROL

The quality of a product/system can be measured using its performance characteristics. If these characteristics are variable in nature can be represented by statistical distributions. The quality of the product can be checked against the laid down target values within pre-specified upper/lower specification limits for each parameter. When such parameters have process involvement, the quality control is referred to as 'statistical process control'. Here, on-line inspections/tests are carried out and compared with standard specifications within the limits. This can identify sources of variability in the process, which can be corrected and modified, if required.

It is essential to know that a particular process is capable of producing a product within the specified limits. Here, capability indices, which are decided in advance, can be compared with the standard deviation of product characteristics, caused by process variability.

QUALITY CONTROL CHARTS

For mass production of products, it is difficult to measure the performance of each component individually, since it involves cost and time. In such cases, samples can be drawn for inspection/testing and their probability density function values are calculated to compare its distribution

with the mean values with upper and lower limits. Charts can be prepared for the samples drawn from the populations. These charts can help the users to accept or reject subgroups of drawn samples. The mean and standard deviations are calculated for each sub-group before making a comparison. This helps in identifying a defective sub-group only, a good amount of time is saved in carrying out inspection/testing of entire population.

THE ACHIEVEMENT OF QUALITY

As indicated in earlier discussions, quality of a product/system starts from its raw material to the finished product. To achieve high quality of any product it is essential that at a first stage, the raw material must of desired quality. Defects do occur during manufacture of product/system, it is therefore, necessary to check the process through which a product has to undergo. Inspection/testing also play important role in manufacturing of good quality products. So, due care should be taken during such activities. Proper handling of product is also essential to maintain its quality at the user's end. Sometimes it is observed that many products/items get damaged during their transaction. Even during installation of equipment, care has to be exercised to maintain its quality. Products/systems can only retain their quality with the proper support of all individuals associated with it. At this point of time it should be noticed that the quality of the product in use is also important which, can be maintained by it's proper use.

QUALITY MANAGEMENT

For achieving the desired quality of a product an effective quality management is essential, which can be better managed by a quality manager. The responsibilities of a good quality manager include the following:

- (i) Setting quality objectives i.e. what level of quality is required for the product, since it involves cost.
- (ii) The formulation of quality system to achieve the objectives set by the organizations.
- (iii) Implementation of the quality system for effective results, which needs cooperation of all associated persons.
- (iv) Preparation of quality manuals for giving the details of quality system to be practiced in the organisation.
- (v) Training and education of the personnel who are involved in the design and production systems.
- (vi) Information recording should be done properly to know the deviations from the set norms.
- (vii) Proper testing/inspection of the product/equipment with the help of authentic testing devices.
- (viii) To take corrective action as and when required, to achieve desired quality.
- (ix) Quality system audit is also essential to know its implementation at all stages of production.
- (x) Financial benefits associated with quality system, must be calculated to justify its application in any organisation.

IMPACT OF QUALITY ON RELIABILITY

It is observed from failure analysis of equipment that good quality products/components have less number of failures as compared to poor quality parts. If proper attention is paid to the quality of products their failures also will be minimized. The quality not only improves reliability of equipment/system but also aids to its value, which is very vital in today's technologically developed nations. While evaluating the overall reliability of equipment, the reliability of each part/component is taken into account. Therefore, the impact of quality on reliability is very vital and significant. The quality products also draw attention of the users/customers, as the maintenance problems associated with such equipment/services are also minimised.

QUALITY DESIGN REVIEW

Independent checks must be carried out to ensure the design meets the quality specifications as defined by the parameter design variables. The review team must closely work with design team for suggestions for improvement at appropriate stages in design. All design changes resulting from this review process should be controlled and documented. Again there should be independent checks that any redesign also meets the quality specifications.

In the next step the paper design should be changed to prototypes. Here a number of prototypes, each with different design parameter are built, each one is tested over a specified set of values of random input variables. Here again there should be independent checks to ensure that the chosen prototype design meets the quality specifications.

The random variables for the process will be made up of the following:

- (i) Random variables in input components and material. The design parameter variables for product can be used to identify these random variations.
- (ii) The random variations in the process itself.

QUALITY IN MANUFACTURE

The quality of the product mainly depends on the input variable such as material of the product and its manufacture process. To control the above two variables the concept of quality control must be applied to maintain the specification limits. The test procedures to be used should be agreed between component/material suppliers and the customers. Sampling techniques are essential, if there are large number of components/parts, again this must be agreed by supplier and customer.

All manufacturing process are subject to random variations because of human factors. To eliminate the human factor the use of automatic/computer controlled machines/equipment can be used. Sometimes, automatic processes also show variability mainly due to temperature variations.

QUALITY TESTS

The quality test are required to show that the finished product (i) meets the specification with desired performance and (ii) also meets specification for continuous performance characteristics.

QUESTIONS

1. Discuss the role of quality associated with reliability.
2. How can quality control of products be done, discuss briefly?
3. Enlist the basic principles of quality in reference with reliability.
4. What is statistical quality control? Explain it.
5. Discuss how can the concept of total quality be applied to engineering products.
6. Explain how can quality be achieved in practice.
7. Discuss the need of quality management.

**This page
intentionally left
blank**

Principles of Quality

INTRODUCTION

Quality has been the integral part of all products including services. The word quality is generally associated with manufacturing organizations to maintain the required standard/quality of their products. While it is important that the quantity requirements and the specifications of the product is also the main concern of organization but it is most important that the finished product meets the desired quality standard as well. Because, the customers satisfaction can be derived from the quality of products and services. With the development of techniques, organizations have to face tough competition to market their products at national and international level. The awareness of the customers require, production of quality products/services for the survival and growth of organization. It is the quality of product and productivity which can bring prosperity into the development of country and improve the quality of the life of their follow citizens.

The objectives of the management are to achieve customers satisfaction by running its business at a desired economic level. Both these can be obtained by properly integrating quality development, quality maintenance and quality improvement of the product. The integration of the above three factors can be achieved through sound quality control system.

Quality has undergone conceptual change with process of evaluation. Initially, it was associated with inspection and later on covered the process control, quality assurance, total quality management, strategic quality management. The inspection and process control was confined to shop floor and quality assurance took care of design process. A wider coverage involving people and the system brought out the concept the 'Total Quality Management' (TQM), further customers brought out the concept of 'Strategic Quality Management' (SQM), encompassing the quality of the product throughout its useful life.

THE MEANING OF QUALITY

The quality of a product or service can be its ability to ensure complete customer satisfaction and will depend upon the use of product. For example, a gear used in sugarcane juice extracting machine may not be as good as in case of lathe machine head stock, but still may be considered of good quality if its work satisfactory. The quality is thus can be defined as the fitness for use/purpose at the most economical level. It also depends upon the perception of a person in a given situation and can be user-oriented, cost-oriented or supplier-oriented. Quality is therefore to be planned, achieved, controlled and improved continuously.

The quality of an engineering product can therefore be measured in terms of number of characteristics that contribute to an overall performance which satisfies customer's requirements; these can be termed as performance characteristics.

The word 'Quality' has different meanings which are explained below:-

1. **Fitness for purpose:** A component is said to possess desired quality, if it works well in equipment for which it is meant. Quality therefore is purpose dependent.
2. **Conformance to requirements:** As stated quality is the ability of product/service to perform satisfactorily in its application for which it is intended or made. This means that quality of a product means conformance to requirements which may differ from user to user.
3. **Characteristics:** Different products may differ in appearance, performance, reliability, taste odor maintainability etc. and therefore quality depends on characteristics of the product.
4. **Degree of the preference:** Quality is the degree to which a specified product is preferred over competing products of equivalence grade based on comparative taste by customers normally called customer preference. Quality is also a measure of degree of excellence of the product and fulfillment of the promises made to the customers.

WHAT IS QUALITY?

Quality is defined as fitness for use with the passage of time, the definition of the quality has seen transformation from initial stage of inspection to Strategic Quality Control. The various definition of the quality are listed below:

- Quality is about doing things right first time and satisfying customers and minimizing cost and maximizing profits.
- The totality of features or characteristics of products, service and process, which bears on its ability to satisfy a given need (British Standard Definition).
- According to Feigenbaum quality is defined as

"The total composite product and service characteristics of engineering, manufacturing, marketing and maintenance through which the product and service in use meet the expectation of the customers".

In the definition of Feigenbaum the quality depends mainly on customer's perception as described earlier. Hence, it is essential that all these factors must be built in the design and maintained in manufacturing which the customer would like to have and is to pay for it for his own satisfaction.

It is therefore concluded that the product should have certain abilities to perform satisfactorily under given conditions. These abilities include:

1. **Suitability** for specific application.
2. **Reliability:** Should perform satisfactorily for a preset time period without failure.
3. **Durability:** Should have life for which it has been designed and fabricated.
4. **Safety:** The given product should meet all safety requirements and fool proof workability.
5. **Affordability:** It should be available at a reasonable cost.
6. **Maintainability:** The product/service should be easy to maintain.
7. **Appearance:** The product should look attractive to draw the attention of the customers.
8. **Satisfaction:** It should satisfy the customers requirements as far as possible.

9. **Cost:** The cost of the product/service should be affordable to the common customers.
10. **Versatility:** The product service should serve member of purposes/functions.
11. **Confidence:** The customers must have full confidence in the product/service which will largely depend upon the reputation of the organization.

CHARACTERISTICS OF QUALITY

A physical or chemical property, a dimension, a temperature, pressure, taste, odor, and any other requirements used to define a product/service is a part of quality characteristics contribute to fitness for use for the product/service and can be of the following types.

1. **Technological:** Which means dimensions of the product, frequency, viscosity of fluid etc?
2. **Psychological:** Which can be sensed by the customers such as taste odor aesthetic look etc?
3. **Time oriented:** This aspect considers the reliability and maintainability of product service. The policy, once decided must be laid down in clear words framing working specifications and should be communicated to all concern from top to bottom.
4. **Contractual:** This signifies the guarantee and the safety aspect of product/service.
5. **Ethical:** Which indicates the honesty and integrity of the manufacturers/service providers?
The quality characteristics may be:
 - (a) Directly measurable such as weight, strength, specific gravity, diameter etc.
 - (b) Non measurable such as rejections due to faulty material design, cracks, breakage etc.

QUALITY POLICY

Quality policy refers to the basic principles which are used to guide the actions of company in order to meet the quality objectives. In past, it was the normal practice to minimize the production cost by cutting down the extra expenditures and at that time the quality of the product was not as important as it is today. Due to tough competition, marketability of the goods is the need of the hour and lot of money is spent in the promotion of sales. But if the quality of the product/service is exemplary, then the task of promotion of sales becomes easy. Therefore, the developed organizations try to take extra care in maintaining the product quality from the very beginning, starting from raw material to the finished products. The following points need extra attention during the installations and development of the organization. Thus, functional use of product and the cost should be considered simultaneously while formulating the quality parameters or policy.

(i) Total commitment for customer satisfaction

Basically the products/services are meant for the customers and therefore their satisfaction is of prime importance to the organizations. Therefore, customer needs have to be assessed and translated into specification depending upon the characteristics required for specific application.

Just as every human has his own characteristics, every application has its own characteristics, which may vary from person to person for example; use of pen may have different requirements/

demands for different people. Hence, these demands of the application are translated into requirements and requirements are quantified. These quantified requirements are called specifications.

Total commitment for customer satisfaction, basically the production/service specifications.

For the development of a product/service these specifications of the customers need to be taken into consideration during the design phase itself, and desired features incorporated at the required level of manufacturing. It should be kept in mind that the customer is the best person to promote the product which he is using.

(ii) Protection and advancement of environment

Working environment plays important role so, for the quality of the product/service is concerned. If a worker is provided with congenial environment his output will be affected. The most important factor among the workers, will be to create quality awareness. Time to time, on job training for employees will also affect the quality and production of the products and services. Four competing theories have been evolved to guide the quality policy of the products

- (a) A capability theory:** According to this the plant should insure that all the machinery/ services render maximum utilization with optimum maintenance cost. The capability of all the workers should be checked to insure the quality and production of the products.
- (b) Usage theory:** It is well known that customer's requirements vary from person to person. Some may like appearance and others may like the durability of the product/ service.
- (c) A competitive theory:** When similar products are manufactured by member of company's the customer have choice or multiple source for supply and they will make competitive comparison with quality and cost. This aspect must be borne in mind during the planning stage.
- (d) An excellence theory:** This factor has to be considered at the top management level, where quality of the product/service is given prime importance be it at the higher cost of the production. The above factors will add for the advancement of the working environment of the organization.

(iii) Market Leadership

It is the quality of the product/service which will make the organization a market leader for a particular product. In the today's, context we find that Shoe from Adidas or Woodland have their position in the market and customers buy them without hesitation with the higher price. The same thing also applies to other product/services. To maintain the leadership in the market most important point will be the quality, which should remain the key factor and be maintained all the times without any compromise on production/demand/supply.

(iv) Strive for quality excellence

Like market leadership, the quality excellence is also the main concern of the top management because, with high requirements of the quality will cost more. The organization who want that their company be known as 'Quality House' without knowing whether an excellence level would cost more or less than other levels and whether it will result in the increased profit or

sales. Initially the product with quality excellence may have poor turnover but in due course of time the sales and profits are bound to increase. Because, the quality product/service will capture market when the customer will realize its importance, since high quality product will have higher reliability. However, the inspection cost should be kept within the optimum level.

(v) Sustainable development of stake holders

Feeling of confidence in the level of quality that customer develop on the basis of what they see, their prior experience and reputation of the company. Service quality is more often difficult to describe in quantifiable measures that can be used within a company to see if work practices are consistent and correct. Once, the customers are identified, efforts should be made to continue business with them, since the customers are the best promoters of the product/service. The relationship with the customers will depend upon how truthfully advertisement are made, extent of guarantees for the products are established. Further, the extent of rigidity or flexibility in setting customers claims for defective items will improve the relationship between the two. The terms and conditions of sale/purchase will also dominate the sustainable development the stakeholders. Every person involved should be given due attention whatever position one has. The cohesiveness of the customers and organization will act as a bond for the quality achievement and promotion of sales.

STATISTICAL QUALITY CONTROL (SQC)

By SQC we mean the various statistical methods used for the maintenance of quality. The quality of the product can be measured using performance characteristics. The quality of product/service is defined using target value and upper/lower specification limits for each characteristic. The comparison of each characteristic with specified limits to decide the acceptability or non-acceptability's termed as 'Statistical Quality Control'. Statistics is basically collection, organization, analysis interpretation and presentation of data and is based on large number of mathematical theory of probability.

Statistical quality control is systematic as compared to guess work, random inspection, and the mathematical approach neutralizes personal bias and uncovers poor Judgement. It consists of the following:

- (a) Systematic collection and graphic recording of accurate data.
- (b) Analyzing the data.
- (c) Management action, if the information obtained indicates significant deviations from the specified limits.

Modern technique of SQC and acceptance sampling has an important role to play in the improvement of quality, and productivity, creation of consumer confidence and development of national economy. The tools used for Statistical Quality Control include the following:

- (a) **Frequency distribution:** Defines or tabulates the number of times a given quality character occurs within the samples. The graphic representation will show (i) average quality (ii) spread of quality (iii) comparison with specific requirements and (iv) process capability.
- (b) **Control charts:** The central idea in Shewhart's control charts is the division of observations in to relation sub-groups. These are taken in such a way that variation within a sub-group may be attributed entirely due to chance causes while variation due to assignable causes, it all exists, I can occur only between sub-groups i.e. from one group to another.

In statistical language, the products with in sub-groups may be supposed to belong to single homogeneous population subject to chance variation only and difference if any among the population corresponding to different sub-groups will indicate the presence of variation due to assignable causes. The most obvious basis for selection of sub-group is the order of production. Each sub-group will consist of product of a machine or a group of homogenous of machines for a short period of time. The use of such sub-groups is wound to tends several assignable causes.

If a plotted point-fall within the control limits then, the process is assumed to be in control at that moment of production. If it falls outside the control limits then the process is said to be out of control at that moment.

Sometimes, even though all the points are inside the control limits, indication of trouble or presence of assignable causes is evident from unusual pattern of points, that is:

- (i) a larger number of points on one side of the central line.
- (ii) a series (or run) of points all falling close to one of the control limit.
- (iii) a series (or run) of points exhibiting a trend.

A run is defined as a sequence of similar type of observations. Obviously, a run of 8 or more points have a very low probability of occurrence in a random sample of points. So any type of run of 8 or more points is often taken as a signal of an out of control condition i.e. an indication of the presence of some systematic (assignable) causes.

A typical control charts as given in figure below:

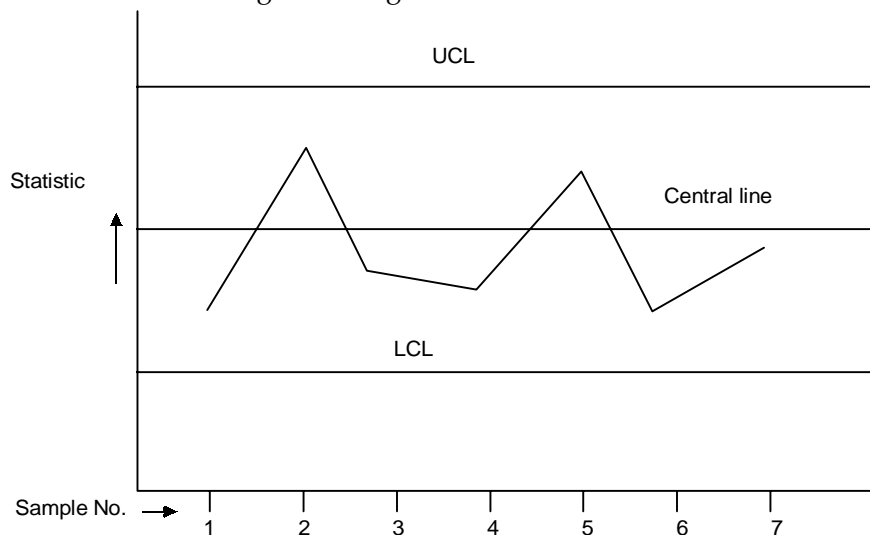

Fig. 12.1: Control chart

Benefits of the Statistical Quality Control

Followings are the benefits which can be achieved by adopting SQC.

1. **Efficiency:** The efficiency of the team is enhanced, since SQC ensures rapid and efficient inspection at minimum cost.
2. **Reduction in scrap:** The causes of excessive variability in manufacturing are identified with the use of SQC therefore, rejection of products/items becomes minimum.

3. **The use of acceptance sampling:** SQC exerts more effective pressure for quality improvement as against 100 per cent inspection.
4. **Fault detection:** Under SQC program by plotting the control charts, it is possible to indicate deterioration in quality with corrective action, which makes fault detection easy and accurate. Production at place where excessive variations are observed can be stopped.
5. **Specification:** As long as SQC is practiced in quality specification are accurately predicted for future, by which it is possible to access whether production process are capable of producing the products within the given set of specifications.
6. Efficient utilization of men and machine is also possible.
7. Better customer relations are maintained through better quality of the product.
8. Eliminations of bottlenecks in the process of manufacturing.
9. Creation of quality awareness amongst the employees.

It should be kept in mind that SQC is not a panacea for assuring product quality. It simply furnishes perspective facts upon which management action can be based.

(c) Acceptance sampling: It is the process of evaluating a portion of the product / material in a lot for the purpose of accepting or rejecting the lot on the basis of conforming or nonconforming to quality specifications. It reduces time and cost of inspection and exerts more effective pressure in the quality improvement that it is possible by 100 per cent inspections. It is used when assurance is desired for the quality of product /service either produced or received. In certain cases, 100 per cent inspection is desirable where reliability of the product/service is of prime importance and particularly where, human beings are involved.

(d) Analysis of data: It includes special methods, such as analysis of tolerance, correction, analysis of variance and analysis for engineering design, problem solving techniques to eliminate causes of problems associated with productions. After analysis of data Statistical Methods can be used in arriving at proper specification limits of product / service starting from raw material, semi-finished product and finished products. It also includes inspection, packaging, sales and after sale services.

COST OF CONTROL

It is the cost to maintain the required level of quality in any organization and is the combination of the following costs:

- Costs to control quality (prevention and appraisal)
- Costs of failure to control quality (internal and external)

The cost of quality becomes the cost of the company, of doing things wrongs, of not conforming to specification. Quality costs can be grouped into four major categories, the first two include the cost to try to control quality and the other two constitute, the costs that are due to failure, to achieve desired quality.

(i) Prevention costs: It consists of the costs associated with personnel engaged in designing, implementing, and maintaining the total quality system. These costs are incurred to keep failure and appraisal costs to a minimum.

The cost of prevention includes:

- Cost of quality planning.
 - Cost of documenting.
 - Process control costs.
 - Cost of training personnel.
 - Costs associated with preventing recurring costs.
 - Cost of investigation and research and correction of defects.
 - Costs incurred in arranging cost consciousness programs.
 - Supplier's evaluation and presentation costs.
- (ii) *Appraisal costs*: This is incurred for auditing service procedures to insure that purchased materials/services conform to the quality standards and performance requirements. These costs include the following:
- Process capability measurement (e.g., control charts)
 - Tests, gauges and other test requirements.
 - Prototype testing and inspection.
 - In process or final inspections and tests.
 - Raw material inspection and testing.
 - Maintenance and recalibration of testing equipment.
 - Quality audits.
 - Review of test and, inspection data.
- (iii) *Internal failure costs*: This cost is incurred due to defective products, components, and materials that fail to meet out the quality requirements and result in manufacturing losses, which include the following:
- Cost associated with scrap.
 - Redesign cost or re-work cost.
 - Cost of re-inspection and retest.
 - Costs due to sale of defective items (seconds)
 - Cost of delays and penalties.
 - Cost of administrative time to review non conforming materials for disposition.
 - The costs of process yield lower than might be attainable by improved controls.
- (iv) *External costs*: These costs incur when defective products are supplied to the vendors/customers and include the following:
- Warranty costs.
 - Product liability (insurance and settlement)
 - Costs of inspecting and repairing the defective products.
 - Costs of replacements made to customers due to the sub- standard /defective products.

It is estimated that cost of correcting their own mistake i.e., cost of failing to control quality may be as high so 40 per cent of sales for some companies and industry averaging about 25 per cent. It has been found that cost of bad quality is in essence-infinite to a company that goes out of business because its customers demand high quality and can obtain elsewhere. The best way to keep quality cost low is to make items/products correctly the first time and avoid the customers associated with poor quality.

It is usual belief that quality problem starts on factory floor. In fact they are more likely to start in a place other than factory—in product design, manufacturing, engineering, training, purchasing customers order processing or elsewhere. As per quality Guru "Edward Deming" management is responsible for 80 per cent of the quality problem in a factory and workers are

responsible for only 20 per cent. Some estimate that product in design itself is responsible for 50 per cent or more of a product quality problems.

Typical breakup of cost of quality (COQ)

A survey conducted concludes the typical break-up costs of quality for a company as shown below:

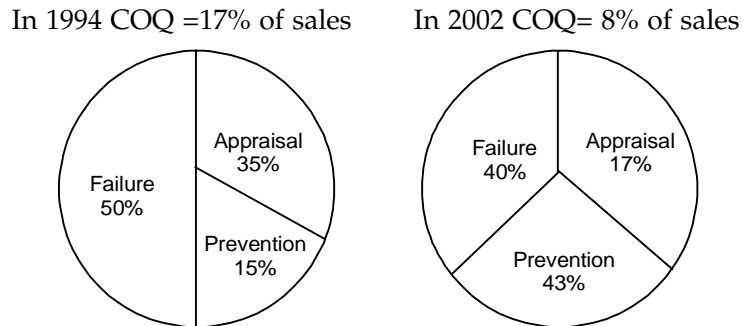

Fig. 12.2: Break-up of Cost of Quality (COQ)

From above, it is seen that when company redirects its corporate culture towards improving quality then its cost of quality came down to 8 per cent from initial 17 per cent.

ECONOMICS OF QUALITY CONFORMANCE

The figure below shows that costs of quality conformance include failure or appraisal costs, prevention cost. However, the failure costs dominate the total cost. So, if the same is minimized the total quality conformance cost will be minimum.

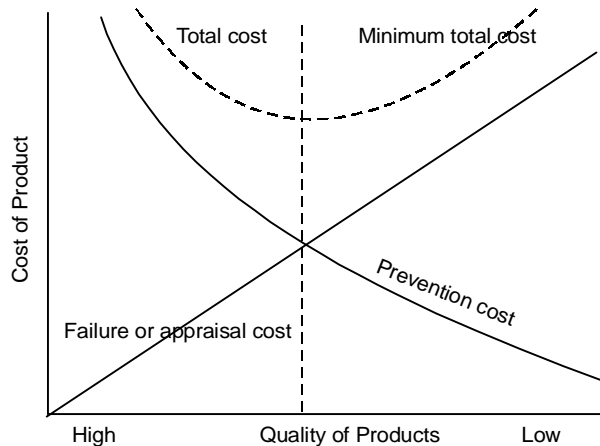

Fig. 12.3: Cost of quality conformance

From figure, it is clear that when the failure cost dominate (left hand zone), the total cost can be reduced by reducing the cost of failure. This necessitates attack on main defect

concentration areas. On the other hand, when the appraisal costs dominate (right hand zone) the total cost can be reduced, by widening the tolerance, reduction of more effective inspection, test procedure, etc.

Value of Quality

It is observed that with superior quality, the organization can earn higher share of market with high price and ultimately higher benefits to the concern. These extra earnings to the organization add to value. Hence, value of quality, can be defined as the return direct and indirect gained by the manufacturer due to mission of quality control.

Value of quality is composed of:

- (i) Value inherent in the design.
- (ii) Value inherent in the conformance to that design. As a rule, higher quality of design means higher values. It is easy to evaluate cost of quality but difficult to assess the value of quality. The value of quality is to be assessed considering various factors given as under:
 - (i) Savings due to increased production and sales.
 - (ii) Reduction in scrap and re-works cost.
 - (iii) Indirect factors: Such as reputation and good will, of the manufacturer.

Optimum Quality

A balance between the quality of products/service and cost must be maintained through optimum design. It is normal practice for the manufacturer, to earn maximum profit but at the same time the quality should also be maintained. Which is possible through 'Market Survey'? During the survey expected sales of the particular quality, profit and competition in the market is to be considered. The quality of the product/service should meet the customer requirements, as well as, the manufacturing cost, which should yield maximum profit. The aim should be, to maintain quality at optimum production cost. The cost of quality and value of quality must be compared during the design stage so that the profit is always maximum. Specification of quality:

The demands of the application are translated into the requirements and the requirements are quantified. These quantified requirements are called specifications. The specification, thus contains the list of essential characteristics and their tolerances. A designer through drawing or CAD defines, the concept of his mind for a particular product or service.

Primitive forms of industrial organizations did not require specifications because the producer and customer met face to face with the product for the evaluation by both the parties. In today's context specifications are needed because of product's complexity and the high requirements of the customers. The quality specification takes on the characteristics of industrial laws to specify what is right or wrong.

The quality specifications may include the following:

- (i) Material specifications.
- (ii) Process specifications.
- (iii) Criteria for acceptance and rejection.
- (iv) Method of use.
- (v) Method of testing.
- (vi) Complete programmes.

One specification may be sufficient or separate specifications may be required to describe the quality characteristics in the material, products/service etc.

The specification of EN 32 will give complete information about what the customer wants. With the help of specifications, the production departments know what material, machine, tools are used and what to make at the same time inspector will know, how much to inspect and so on.

Use of the specifications.

These generally contain:

- (i) Description of conditions under which the product is wanted to be used.
- (ii) Procedure for installation, precautions to be taken, while using or operating.
- (iii) Operating procedures.
- (iv) Maintenance procedure.

QUALITY CONTROL AND INSPECTION

Inspection means checking of materials, products, or components at various stages to find out defectives items which do not meet the preconceived specifications. On the other hand, quality control involves inspection at particular stage to improve the quality of the product/service. Inspection is an act of checking parts/components at various stages to find out defective ones, whereas quality controls is an effective system for integrating quality development, quality maintenance and quality improvement by various groups, in the organization. In inspection, we use precision measuring instruments but under quality control, statistical control charts, acceptance sampling, quality audits are used. Inspection is concerned with quality of past products, whereas, quality control is concerned with quality of future production. For inspection, inspectors are responsible but in case of quality control everybody working in organization is responsible.

Feedback in Quality control

Feedback information on production/service quality has great importance in quality control, without feedback it is difficult to control quality at a certain level.

In feedback system, attained quality is, compared with the desired quality and any deviation between the two, corrective actions is to reach the desired level. The desired level is defined by setting up quality requirements or quality objectives.

Quality perspective

There are two view of quality—the conventional, internal view, which is followed in many organizations as on today and the modern, external view that many organizations found to be imperative for survival and growth. There are two types of qualities namely:

- (i) Quality in fact, which the provider meeting the laid down specification for the product or service.
- (ii) Quality in perception, which is subjective in nature as seen by the customer. It satisfies the customers' expectations.

The broad application of quality concepts and participation of all employees has given rise to Total Quality Management (TQM), which is the system of activities directed of achieving delighted customers, empowered employees, higher revenues and lower costs of products/services.

QUESTIONS

1. Define the term quality: state the various factors which affect the products quality.
2. What is meant by quality conformance? Explain the factors which influence the quality of conformance.
3. Discuss the statements, higher quality of design means higher cost quite often it also mean higher values.
4. What do you mean by cost of quality and value of quality? How to balance than?
5. Discuss various quality characteristics in brief.
6. Explain why optimum cost of performance is important in context of quality control.
7. What is statistical quality control? How it is used in practice to improve the quality of products?
8. What are the main benefits of SQC?
9. Explain the following an applied to quality control:
(a) Appraisal costs (b) Preventions costs (c) Failure cost (d) Optimum costs.

Total Quality Management

INTRODUCTION

Total Quality Management (TQM) is an effective tool for the improvement of quality with the support of all the employees of an organization. A further step, based on the definition of quality as the fitness for the purpose as seen by the customer brought out the concept of 'Strategic Quality Management (SQM) encompassing the quality of the product/service throughout its life. Today the organizations do not talk much on quality but take necessary actions to achieve it as they know it is critical factor for their survival in the market.

TQM gives stress on prevention of defects rather than setting it right by rectification. It approaches towards quality in all its forms in people and processes, in products and costs in planning and management. All the operations of an organizations i.e. market research, the need of the customer, the optimal use of the raw materials and other inputs, product development and design, manufacturing process, sales, service after sales the whole of it comprise total quality.

Total quality management is an active approach encompassing company's wide operating philosophy and system for continuous improvement, leadership and motivation. The quality functions include:

- Development of product/service specification based on the need of the customer.
- Interaction with product development and design.
- Reliability and development testing.
- Process capability studies.
- Quality planning for control of production process/operations.
- Quality control of incoming material/facilities.
- Vendor quality control and development.
- Inspection and testing during manufacture.
- Training of staff and customers, quality audits.

PRINCIPLES OF QUALITY MANAGEMENT

It is a comprehensive rule for leading and operating an organization, aimed at continuously improving performance over the long term by focusing on customers while addressing the needs of the other stake holders.

Following are the principles for quality management:

(a) Customers focused organization

Organizations depend on their customers and therefore should understand current and future needs, meet customer requirements and strive to exceed customer expectations. The steps in application of this principle are:

- Understand customer needs and expectations for products delivery, price, dependability.
- Communicate these needs and expectations throughout the organizations.
- Ensure balance approach among customers and other stake holders, need and expectations.
- Measure customer satisfaction and act on results.
- Manage customer relationships.

(b) Leadership

“Leaders establish unity of purpose and direction of the organizations. They should create and maintain the internal environment in which people can become fully involved in achieving the organizations objectives.” Steps in application of the principles are:

- Be protective and lead by example.
- Understand and respond to changes in the external environment.
- Consider the needs of all stakeholders including customers.
- Establish the clear vision of the organization’s future.
- Establish shared values and ethical role models at all levels of the organization.
- Build trust and eliminate fear among the workers.
- Provide people with the required resources and freedom to act with responsibility and accountability.
- Inspire, encourage and recognize people’s contributions.
- Promote open and honest communication.
- Educate, coach and train people to achieve desired targets.
- Implement a strategy to achieve these goals and targets.

(c) Involvement of people

“People at all levels are the essence of an organization and their full involvement enables their abilities to be used for the organization’s benefits”. Steps in application of this principle are:

- Accept ownership and responsibility to solve problems.
- Actively seek opportunities to make improvements, and enhance competencies, knowledge and experience.
- Freely share knowledge and experience in teams.
- Focus on the creation of value for customers.
- Be innovative in enhancing and improving organizations objectives to meet out the latest requirements/needs of the customers.
- Improve the way of representing the organization to the customer’s local communities and society at large. This can better be done with the creation of website of the organization.
- Make people enthusiastic and proud to be part of the organization.

(d) Process approach

“A desired result is achieved more efficiently when related resources and activities are managed as a process”. Steps in application of this:

- Define the process to achieve desired results.
- Identify and measure inputs and outputs of the process.
- Identify the interfaces of the process with the functions of the organization.
- Evaluate possible risks consequences and impacts of processes on customers, suppliers and other stake holders of the process.
- Establish clear responsibility authority and accountability for managing the process.
- Identify internal and external customers, suppliers and others stake holders for the process.
- When designing process, consider process steps, activities flows control measures, training needs, equipment, methods, information materials, and other resources to achieve the desired result.

(e) System approach to management

Identifying, understanding and managing a system of inter related processes for a given objective involves the organizations effectiveness and efficiency. Steps in application of this principle are:

- Define the system by identifying or developing the processes that affect a given objective.
- Structure the system to achieve the objective in the most efficient way.
- Understand the interdependence among the processes of the system.
- Continually improve the system through the measurement and evaluation.
- Estimate the resources requirements and establish resource constraints prior to action.

(f) Continual improvement

Continual improvement should be permanent objective of the organization. Steps in application of this principles are:

- Make continual improvement of products processes and systems an objective for every individual in the organization.
- Apply the basic improvement concepts of incremental improvement and break through improvement.
- Use periodic assessments against established criteria of excellence to identify areas for potential improvement.
- Continually improve the efficiency and effectiveness of all processes.
- Provide every member of the organization with appropriate education and training on the methods and tools of continual improvements.
- Establish measures and goals to guide and track improvements.
- Recognize improvements.

(g) Factual approach to decision-making

Effective decisions are based on analysis of data and information made available to the users. Steps in application of this principle are:

- Collect authentic information/data relevant to the objective.

- Check the reliability of data.
- Analyze the data/information using valid methods.
- Understand the value of appropriate statistical technique.
- Make designs and take action based on the results of logical analysis balanced with experience institution.

(h) Mutually beneficial supplier relationships

An organization and its suppliers are interdependent and a mutually beneficial relationship enhances the ability of both to create value. Step in application of this principle are:

- Identify and select important supplier.
- Establish supplier relationships that balance short-term gains with long-term considerations for the organization and society at large.
- Create clear and open communications.
- Initiate joint development and improvement of product and processes.
- Jointly establish a clear understanding of customer's need.
- Share information and future plans.
- Recognize supplier's improvements and achievements.

PHASES OF TOTAL QUALITY MANAGEMENT

The phases of total quality management are:

- (a) Comprehension:** The quality should be well defined and be measurable.
- (b) Commitment:** The policy and concepts should be clear to all the employees of the organization.
- (c) Competence:** Develop method, tests, procedures, evaluate quality and understand the price for non conformance to quality.
- (d) Communication:** Create awareness, resolve conflicts coordinate activities and create an image of product/service quality and reliability among the workers.
- (e) Correction:** Solve the problems of non conformance of quality which are largely due to lack of knowledge and understanding. Sometimes lack of facilities also play important role.
- (f) Continuance:** Maintain the importance of quality, ensure exposure to sustained programme, innovation etc.

Try to introduce new methods and technique in design and manufacture.

Total quality control covers the above concepts and envelops all activities of product quality such as product design, product development, prototype development and testing etc. It also provides feedback at various stages for comparison with standards and for initiating control action to bring about modification and change at appropriate stages.

LEVELS OF QUALITY MANAGEMENT

In last 20 years simple inspection activities have been supplemented by quality control and quality assurances have been developed and redefined. Levels of quality management, include the followings:

(a) Inspection

Under inspection based system one or more characteristics of a product/service are examined, measured or tested and compared with specified requirements to assess its conformity. This system is applied to the incoming goods, manufacturing component and assemblies at appropriate point. Goods or products which do not conform to specification are scrapped, reworked or passed on concessions. It is screening process with no prevention of faults.

(b) Quality control

Under this scheme the following methods/techniques are employed.

- Raw materials and intermediate stage product testing.
- Inspection by the operators.
- Feedback of process information to operators/production supervisors.
- Use of basic statistical methods.
- Process control.

(c) Quality assurance

It contains all those planned and systematic actions required to provide adequate confidence that a product/service will satisfy given requirements for quality. The models/techniques used for quality assurance include:

- Statistical process control.
- Failure mode and effect analysis.
- Involvement of non production operations.
- Use of quality costs.
- Comprehensive quality manuals.
- Advanced quality planning.
- System audit and third party approval.

(d) Total quality management (TQM)

The fourth and highest level involves the application of quality management principles to all aspects of the business. Quality management is defined as that aspect of the overall management function that determines and implements the quality policy and as such is the responsibility of top management. Besides individual departmental system it would expect the spread of total quality management philosophy to extend beyond the organization itself to include partnership with suppliers and customers. Total quality therefore is quality in entirely taking care of all important aspects i.e., cost, safety, prompt service, design environment protection etc.

TQM use variety of method involve, motivate and imbibe people at all organization level with the philosophy that improvement is the way of life. Key features of TQM are employee's involvement and development of team work. Need for management of product quality.

Today's business has to face the challenges like.

Increase in product complexity and size of operations.

- Stiff competition, national and international level.

“Survival of the fittest” is the slogan of present day business and therefore strict enforcement of quality control measures through sound quality management can alone help the company to withstand national and international competition. The company will have to follow to stay in business.

- Consumer awareness.
- National and international legislation.

To face these challenges, to strive for excellence and growth in business, the responsibility of quality has shifted from lower level employees to higher level management. The focus of productivity have been shifted to productivity and quality. The quality revolution therefore, assumes a tremendous importance in this highly competitive world. The company can survive the tough competition, if it paid attention to plan, achieve, maintain and improve quality constantly to meet the new challenges.

Model of total quality control includes:

- Determine product performance requirements.
- Design includes suggestions, modifications, development of prototype testing.
- **Manufacturing:** Before starting production, make vendor assessment and inspection, quality control, performance, appraisal and product finishing and package. Due attention should be paid to customer complaints for the suggested modification at any level.

Concept and techniques of 'total quality control' and philosophy of quality circles as well as, do it Right First Time, Every Time reflects the integral approach to quality management and envelopes all departments at all levels and all categories of staff. Commitment of top management will help in developing and implementing quality improvement program and projects.

Quality management has moved away from inspection oriented approach (appraisal) to prevention oriented approach. It covers aspects of technology. Statistical process control (SPL), quality assurance system as well as technique for identification of problems and problem solving. Company wide quality and creativity (CWQC) and total quality control (TQC) presents new concepts in quality.

CONCEPT OF TOTAL QUALITY MANAGEMENT (TQM)

The concept of TQM has originated from Japan and is a system approach to quality management and a journey to achieve excellence in all aspects of organizations activity. Since, the quality standards do not remain same forever and are to be modified to meet the changing requirements of the customers and to make use of the newer technologies. The launching of ISO 9000 series standards is an attempt to help the industrial organizations in adopting TQM to improve their quality and productivity.

TQM Definitions

- Total quality management is a culture/philosophy advocating total commitment to customer satisfaction through continuous improvement and innovation in all aspect of business.
- TQM is a way of managing entire organization so that it excels on all dimensions of product and service that are important to the customers.
- It is an enlighten approach to quality encompassing incorporation of quality into the product/service by standing and improving activities that effect quality from marketing through design-to-manufacturing.
- TQM is integrated organizational approach for delighting customers (both internal and external).

- TQM is a combination of socio-technical process towards doing the right things (externally) everything right (internally), first time and all the time with economic viability considered at each stage of each/process.

It demands cooperation from every one in the organization from top management to down to the worker. Philosophy of TQM extends beyond product quality and covers quality life of people. In fact, the primary concern of TQM is people, then comes the products. A company is able to built quality into the people is always half way toward producing quality product.

TQM PHILOSOPHIES

Though, TQM will probably carry on evolving and introducing new concepts and principles but the fundamental principles of quality Gurus like Deming Juran , Philip B Crosby and others will still play important role in creating quality culture in the organizations. The various philosophies are described as under:

Deming approach to TQM

According to Deming, there are fourteen principles for making TQM successful and are aimed at creating an organizational climate in which statistical methods can be implemented for quality improvement. These are:

1. Create consistency of purpose for conditional improvement of product/service.
2. Adopt new philosophy for economic stability.
3. Cease dependence on inspection to achieve quality.
4. Minimize total cost with required quality.
5. Improve constantly and forever the system of production/service with reduction in total cost.
6. Institute training on job for all employees.
7. Institute leadership to help people and machines/gadgets to perform better.
8. Derive out fear so that everybody works freely with transparency in communication.
9. Improve the inter department cohesiveness to work, as a team member.
10. Eliminate the use of slogans, posters, extortion etc.
11. Eliminate work standards on factory floor prescribing numeric quotes.
12. Remove barriers that rob the hourly worker of right to have pride in workmanship.
13. Institute a rigorous program to promote education and self improvement.
14. Define top management's permanent commitment to quality improvement.

Deming's Cycle

This tool is called PDCA (plane -do- check-act) cycle/wheel and can be applied to all process.

- Plan: Establish the objectives and processes necessary to deliver result in accordance to customer's requirements and organizations policies.
- Do: Implement the process.
- Check: Monitor and measure process and product against policies, objectives and requirement for the product and report result.
- Act: Take required actions to continually improve process performance.

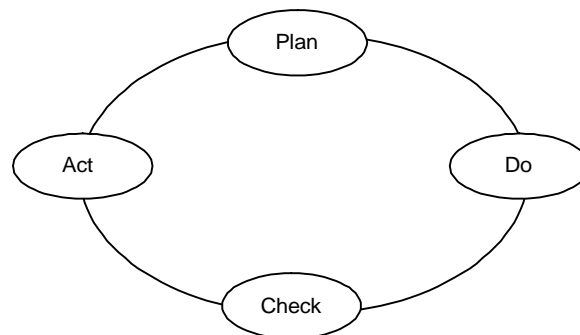

Fig. 13.1: Deming's cycle

Juran's Ten Steps to Quality Improvement

Juran suggested, that three managerial processes are necessary for structured implementation of a total quality program: planning, control and improvement on long term basis and advocated ten steps. Which are:

- Start with building awareness of the need and opportunity for improvement.
- Set realistic goals for improvement.
- Organize to achieve goals through quality council, identification of problems and further remedial actions.
- Train personnel.
- Continue the projects to solve the problem if any.
- Monitor progress.
- Recognize the achievers.
- Communicate results to all concerned.
- Maintain records.
- Continue the improvement for the success of company.

Juran's Trilogy

Juran investigated that 15 per cent problems are due to quality variations in works and 85 per cent problems are associated to management. And therefore, he proposed three managerial processes which are necessary for the implementation of Total Quality Management. Which are?

Quality Planning

Planning of products begins with external customers. Once quality standards are decided, market research determines these external customers. Then the organizational personnel work together to find out internal customers. The number of external customers may be large, select vital ones carefully. Having known the customers, their needs are to discover and translate into requirements.

Next step, would be to develop product/service features that respond to the customers needs, meet the needs of the organization and its suppliers. Check that the costs are optimum.

Taguchi's quality, engineering quality design are the approaches that can be used.

The next step, would be, to develop the processes to produce the products/services features, which includes determination of necessary facilities, training and operation, control and maintenance of the facilities.

Transferring plans to operations is the final step of the planning process. Process validation is necessary to ensure that the process will consistently produce the product/service that meet set requirements.

Quality Control

Control is the tool used by the operating personnel to meet the product, process and service requirements. It uses feedback loop and consists of the following steps:

- Determination of components/items that are to be controlled with units of measure.
- Set goals for the controls and determine facilities that will be required.
- Measure actual performance.
- Compare performance with set goals.
- Take corrective action for discrepancies.

Statistical Process Control (SPC) is the primary technique for achieving control. The other tools are Pareto diagrams, flow diagrams, cause-effect analysis, check sheets histograms, control charts and scatter diagrams.

Quality Improvement

It begins with the establishment of an effective infrastructure such as quality council. The improvement process is continuous and never ending. Juran has shown through example that above three improvement processes are interrelated.

There are four primary improvement strategies: repair, refinement, renovation reinvention. Choosing the right strategy for right situation is critical.

The end results obtained from each process are as under:

- (a) Quality Planning:** The process for preparing to meet quality goals during operations.
- (b) Quality Control:** The process for meeting quality during operations. Conduct of operations in accordance with the quality plan.
- (c) Quality Improvement:** The process for breaking through to unprecedented levels of quality, distinctly superior to planning performance.

Without a sound quality culture the real impact of Juran's trilogy of quality process can not be achieved.

Taguchi Philosophy

Taguchi suggested various concepts for the improvement of quality, which are briefly discussed below:

Concept of parameter design and robust design

To achieve desirable product/service quality Dr. Tagauchi recommends three stage process.

- System design
- Parameter design
- Tolerance design

System design is the development of prototype, which uses engineering and scientific knowledge to define initial setting of product and process parameters. For each parameter the

specifications state a target value and a tolerance range around the target. This process is called parameter and tolerance design. Robust design provides optimum performance simultaneously with variation in manufacturing and field conditions.

Taguchi (1978) has developed a method for determining the optimum values of product and process parameters which will minimize the variations while keeping the mean value on target, so that products/services are robust.

Tolerance design is a step used to fine tune the results of parameter design by tightening the tolerance of factors with significant influence on the product. This will identify the need for better materials, purchase of new equipment, spending more money on inspection etc.

The Taguchi philosophy of quality development is founded on three fundamental concepts which are:

- (a) Quality should be designed and built into the product and not inspected into it.
- (b) Quality is best achieved by minimizing the deviation from target.
- (c) The cost of the quality should be measured as a function of deviation from the standard and loss should be measured system wise.

Taguchi philosophy continually strives to reduce variation around the target value. The product under investigation may exhibit a distribution that has mean value different from the target value. The first step towards improving quality is to achieve population distribution as close to the target as possible. For this Taguchi designed experiments using "Orthogonal arrays "(OA) to make the experiments easy and consistence.

The Concept of Loss Function

Quality loss results from customer's dissatisfaction, which is measured in monetary terms and includes all costs in excess of the cost of a perfect product. This loss may include such things as a result of harmful effects to the society (e.g. pollution), customer complaints and warranty replacements etc. It is argued by Taguchi that performance of product will fall below prespecified level whenever design parameters deviate from target value. Overall quality loss then increases by the square of deviation from the target value i.e. $L = D^2C$ where, L is over all quality loss and D is deviation from target value and C is constant which depends on cost required to improve the quality.

Prevention of poor quality is less costly than rework of product. Therefore, minimization of quality loss is essential for the survival and growth of the organization.

Orthogonal Arrays

It represents a simplified method of putting together an experiment. The original development of concept was by Sir R.A. Fisher of England in 1930's. Taguchi constructed a special set of orthogonal arrays. His approach takes each of the factors at two level (usually, the extremes) and works out which has the greatest contribution to the end result. These factors are then studied in more details.

Crossby Concepts

Crossby proposed four absolutes of quality, stated as under:

- (i) **Definition:** Quality is conformance to requirements and not goodness.
- (ii) **System:** Prevention and not appraisal.
- (iii) **Performance standards:** Zero defects; not that are close enough.

(iv) Measurement: Price of non conformance to requirements, and not quality indices. Further, Crosby proposed a check list to monitor quality improvements.

- Management commitment—for quality commitment
- Quality improvement team—structure of quality
- Quality measurement—target setting
- Cost of quality evaluation—poor quality consequences
- Quality awareness—company's quality culture
- Corrective action—defect prevention
- Zero defect planning—quality planning
- Supervisor training—training and education
- Zero defect day—reward for quality
- Goal setting—quality levels
- Removal of error causes—quality problem solving
- Recognition—quality improvement
- Quality councils—continuous improvements
- Do it all over again—company's quality quotient

Armand V. Feigenbaum's Contribution

According to Feigenbaum quality control must start with identification of customer quality requirements and end only when the product has been placed in the hands of the customer who remains satisfied. He identified nine M's which include Materials, Men, Money, Motivation, Management, Markets, Machine and Mechanization, Modern Information Methods and Manufacturing Process Control. He believed that quality professionals have to play significant role in quality improvement to identify it, to make it clear and to help others to achieve it, since it is every body's job.

Ishikawa's Contribution to TQM

Ishikawa is considered leading scientist to investigate quality related problems in Japan. He first introduced concept of Quality Circles and designed Fishbone diagram which is widely used for representing cause-effect analysis to diagnose quality problems. He proposed 'Seven Basic tools' for quality management, which are:

- Process flow chart
- Tally chart
- Histograms
- Pareto analysis
- Cause-effect analysis
- Scatter diagrams
- Control charts

Quality Circles

It is an informal group of 5 to 12 employee's from same work area who meet occasionally on voluntary level to solve the problems under the supervision of circle facilitator using scientific tools in a systematic way. These groups include persons from management and work force as well as supplier's and sub-contractors. The main advantages of quality circles are:

- This strengthens the team spirit.
- It helps in setting and attaining reasonable targets.
- Improves morale, greater sense of belongingness.
- Improve communication in the organization.
- Promotes cost reduction exercise.
- Promotes personnel and leadership development.
- Harmonize manager—worker relationship.
- Promotes initiative and substantially develops the ability to solve problems.

Control Charts

These are used to separate out the assignable causes of quality variations. They are used to distinguish between inherent random variability of a process and the variability attributable to assignable causes. Random samples of work in process are taken and inspected. Data collected are then presented graphically in chart form. The control limits are then derived and are directly related to $\pm 3\sigma$ -limits which becomes a basis to judge variations in process.

TOTAL QUALITY MANAGEMENT (TQM) MODELS

Some of the important models are:

(i) Integrated model of TQM

This was proposed by Sohal Tay Wirth in 1989 and consists of five elements.

Customer focus

Management commitment

Total participation

Statistical quality control and Systematic problem solving process

The model stresses that the mission of continuous quality improvement can be achieved to deliver satisfying service to the customer by:

- Involving people at gross root level.
- Improving their morale, sense of belongingness and responsibility.
- Using statistical methods for analysis.
- Adopting Plan Do Check and Act (PDCA) cycle.

(ii) The building Blocks of TQM

This was proposed by Zaire in 1991 and looks at TQM at three levels which are:

(a) Foundation

- Continuous improvement
- Added value management activity
- Employee involvement

(b) Pillars

- SPC, SQC
- User supplier chain
- Management control, system
- Progress flexibility
- Work place design

(c) The Top

- Quality planning
- Leadership
- Vision for world class competitiveness

(iii) The house of TQM model

It was proposed by Kano in 1993. In the house of TQM, the portion from the floor up to the roof is TQM. The floor signifies 'Motivational Approach' and the roof shows 'Customer satisfaction/Quality assurance' which is the aim of the TQM. The three pillars of the house of TQM are:

- (a) Concepts:** Shows how to proceed from a particular perspective to achieve satisfaction of the customers with the given facilities.
- (b) Techniques:** For analysing the collected data, the tools used include: Scatter diagram, Check sheet, Graphs and charts, Histograms, Pareto diagram, Cause and effect diagram and Control charts.
- (c) Vehicles:** Includes management by policy, routine management and quality circles for improving and promoting activities effectively and efficiently.

(iv) Interactive Environment Model of TQM

The role of working environment is very crucial for achieving success in every walk of life and that also applies to quality attainment. This environment consists of:

- Technical environment
- Economic environment
- Supplier environment
- Customer environment

Next step, in the interactive model is focal business system, where every individual is responsible of good and bad taking place in the environment. The disturbances in the quality can be from external sources as well as internal sources.

The improvement can be brought in by:

- Management commitment
- Quality tools and techniques
- Culture change
- Training and education
- Work environment change

If the above program can be followed continuously will provide:

- Improved quality of work life
- Employee satisfaction
- Profitability
- Customer loyalty
- Increased market share

OBJECTIVES OF TQM

Following are the main objectives of TQM:

- Customer's satisfaction

- Improvement of quality at every level
- Participative and integrative approach to work
- Change in organizational culture
- Cost reduction/maximization of profit
- Integration of various systems of the organization

Valuable tools for quality

Followings are the main tools for attainment of quality:

- Management tools for quality
- Statistical tools for quality

Both above tools have common aim, improvement in quality. First category of tool will be more useful to the managers and the second one will be for the people who are concerned with technical side. Dr. Deming's technique fall under the banner of Statistical Process Control (SPC) and methods advocated by Dr. Taguchi are under management tools. The generic tools of TQM are those developed for statistical process control, the tracking tool, which include Praeto analysis, histogram, check list, cause and effect diagram(fishbone diagram).

Scatter diagram, run chart, control charts etc.

SPC tools commonly used for improving quality are:

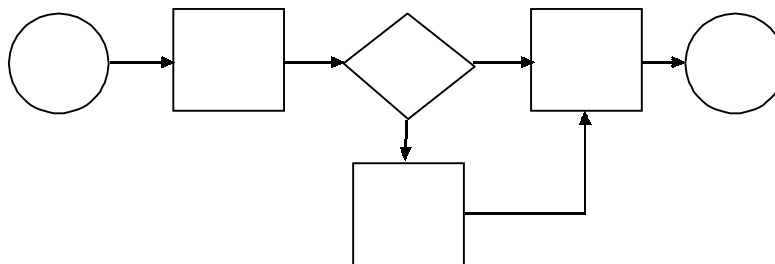

Process Flow Chart

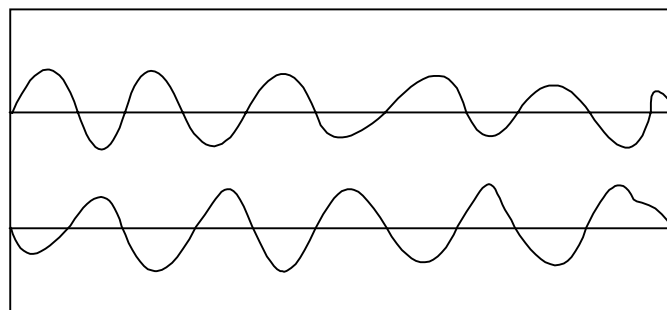

Control Charts

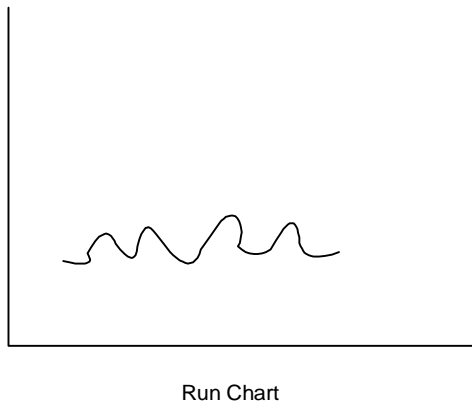
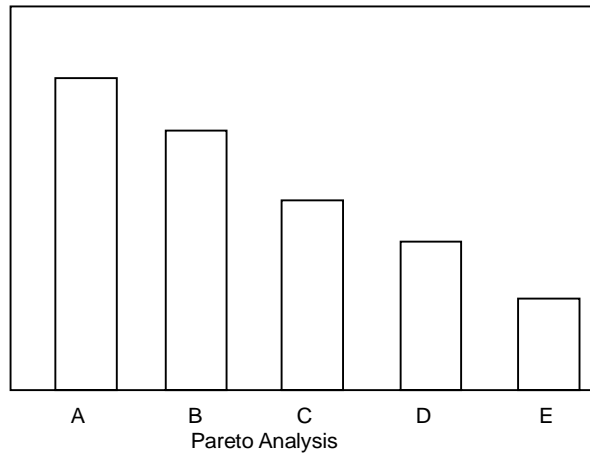

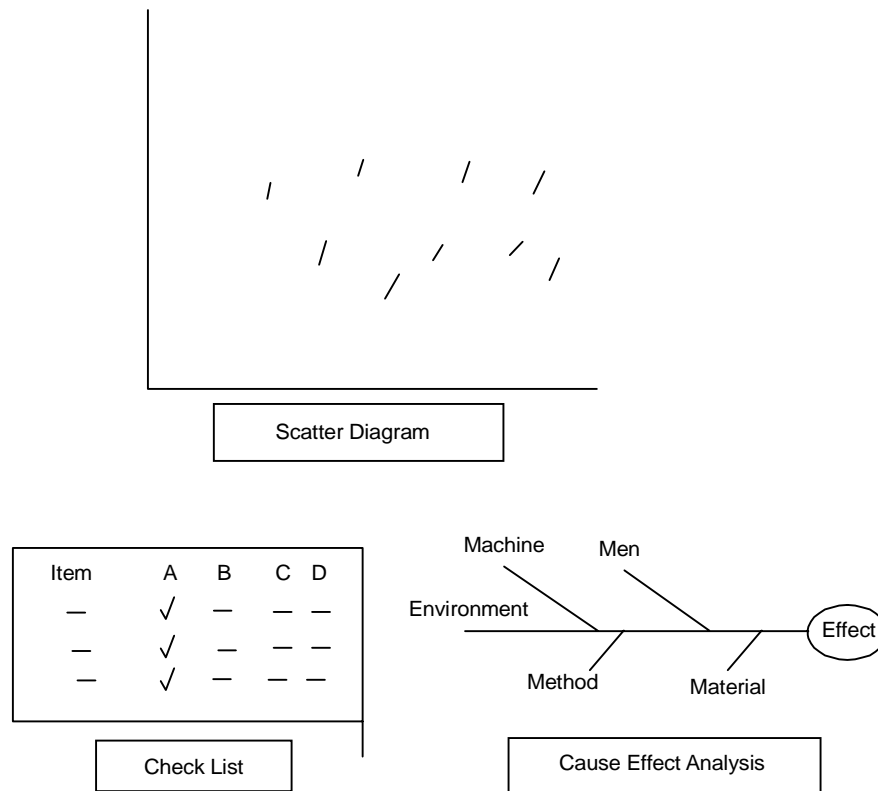

Dimensions of TQM

The important dimensions of TQM are:

- **Excellence:** The objective should be close to perfection (zero variations)
- **Universality:** Quality improvement applies to all factors such as products, process, customers and employees. Therefore, every one's role is crucial and important.
- **Perpetually:** TQM provides steadiness of progressive steps which direct us to attain perfect quality through innovative approaches of process, using structural systematic and analytical approach to problem solving.

TQM Operations

TQM operation encompasses four P's which are:

- (a) People involvement through leadership, team work consciousness and recognition of achievements of the individuals.
- (b) Process/Product Innovation—includes:
 - Do just in time
 - No in process inventory
 - Innovation for better quality
 - Elimination of waste
- (c) Problem Investigation—it includes the following:

- Eliminate waste (minimum rejection)
 - Control problem solving (Analytically)
 - Reduction in variability of parameters i.e (zero defect approach)
- (d) Perpetual Improvement—it includes:
- Planning/innovation
 - Manufacture (Do)
 - Inspect/checking
 - Act implementation
 - Zero defect concept

Zero Defect (ZD) Concept

It seeks voluntary participation of workers in understanding the requirements of high quality and their contribution to achieve it. Cross by in 1961 developed the concept of zero defect and was applied to a Missile production program for the US Army. Martins technique was to establish a running production line inspection by the operators who were pledged to achieve necessary quality standards.

Steps in ZD Programme

- (a) **Personal challenge:** Here, the workers/operators were challenged to volunteer themselves for the improvement of quality of their products/services and were made to sign a pledge in this regard.
- (b) **Identification of error-cause:** The causes of defects in the products are of simple in nature and can be identified and rectified easily with the confidence of the employees. Therefore, the cost of the complete product/service can be minimized.

Implementation of TQM

W.E. Deming has suggested a scheme to implement TQM through Plan-Do-Check-Act cycle.

Plan: Policies and objectives of the organization. Find method to achieve desired objectives.

Do: Educate and train the employee's to accept the change in working environment. Implement the change.

Act: Prevent undirected effects. Incorporate measures for improvement.

Check: Observe the results, analyze the results.

Suggest measures for improvement of methods and design in future.

QUESTIONS

1. What do understand by total quality management? Explain briefly.
2. Explain briefly the principles of quality management.
3. What are the levels of quality management? Describe briefly.
4. Discuss Juran's ten steps of quality management.
5. Explain how Tagauchi's philosophy helps in achieving total quality management.

6. What is Armand V. Feingenbaum's contribution with regard to quality management.
7. Explain briefly:
 - (a) Quality circles
 - (b) Control charts
 - (c) Orthogonal arrays
 - (d) Deming's cycle
 - (e) ZD concepts.
8. What are the objectives of TQM? Explain.
9. Explain important tools for quality improvement.

ISO 9000 For Quality System

INTRODUCTION

To maintain uniformity of products in all respect, it is desired that a standard must be set for each product. To ensure quality it has to be ensured at all levels of design and production, since quality depends on every person working in the organization. Every employee's involvement is utmost important in understanding the problems, finding solutions and implementing them. All these actions will lead to maintain and improve quality and reliability of the product/service system. With this in mind manufacturer can assure the quality of product and can guarantee its performance with full confidence.

It is essential that ISO certification come as result of a real desire to improve the quality and competitiveness of the organization. Too many organizations undertake this ventures simply to obtain the certificate. This manner of viewing the certification process shows not only absence of vision and strategy within the company but a lack of commitment to respect customer requirements and achieve quality and customer satisfaction. It is of prime importance that the upper management involves itself formally in the process, that employee's be involved and consulted, that precise objectives be set and that all steps be followed and respected. It is also necessary that the standard be well understood and the registrar, with whom one will be working be carefully chosen as should be consultant, who will assist in the realization of this fruitful undertaking of ISO standards.

NEED FOR STANDARDIZATION

Company standardization is now an important effective management tool for improving quality and productivity. Quality and standardization are two essential pre-requisites for an organization to market its products/services in the competitive market. Quality thus begins with standards. Quality includes safety, reliability, durability, performance and acceptability of products/services by the customers. Hence, quality needs are to be built in the products during research, design, development and production and in fact the foundation on which the quality is built is the standards.

Standardization is selection/adoption of the best acceptable solution to research problem, formulated in a scientific and systematic manner by grouping the knowledge of all those who are concerned with the problem and is subjected to review and revision by common consent. It promotes the optimum overall economy of the organization by taking due care of functional and safety requirements. And also deals with the other aspects like variety reduction in size, type and grade of products and services through rationalization, selection of alternative material/process and thus results in cost savings without affecting the quality of the

products/services. With the advancement of technology, the methods of production/planning have seen some changes which can bring improvements in the suitability of goods and services for the intended purposes.

LEVELS OF STANDARDIZATION

It is multi-tier system i.e. company standards; material standards, regional standards and International standards like ISO. Standardization at each level should make maximum use of standards issued by the appropriate organization of the next higher level.

As the standards move from one level to next higher level they should meet an increasingly diversified and enlarged set of needs. Hence, the National and International standards are more broad based and covers only essential parameters from the users' point of view; company standardization on the other hand, meets the requirements of purchase, design, development, manufacturing quality assurance and after sales services.

ISO 9000 SERIES STANDARDS

These standards on quality system were formulated by International organization for standardization in order to meet the requirements of Internationally uniform quality system. In simplest terms ISOP 9000 directs you to document what you do and then do as you have documented. This may be considered as a path towards TQM and becomes a base line from which to start quality improvement activities. Using ISO 9000 for this assessment would provide an excellent measurement criteria and a structural approach to periodic evaluation of the quality system. It is designed to ensure its adherence to it. If ISO 9000 standard is integrated into TQM from start it can become a long term critical success factors.

ISO 9000 certification standards put forth by International organization for standardization (ISO in Geneva) now play a major role for setting quality standards for global manufacturers. It is recognized as a symbol of quality and prestige. To date 95 countries have approved these standards for voluntary application in both manufacturing and service sectors. It does not necessarily relate to quality of a company product or services but signifies that a company has fully documented its quality control procedures what ever they are and in abiding by them.

ISO: 9000 quality standards stipulate certain management practices as guidelines and minimum requirements for making quality of products and services conforming to the needs of customers. These are developed for facilitating International exchange of goods and services. All these systems are self-disciplined standards based on the principles of harmonization of specification and continuous monitoring by third party.

International organization for standardization has developed the following standards on quality systems.

ISO: 8402:1986(Is 13999:1988) Vocabulary

This gives definition of various terms (example, Quality, Inspection, Reliability, Specification etc.) used in development of quality systems. Definition of important terms related to quality is as:

Quality: It is the totality of features and characteristics of a product or service that bear on its ability to satisfy stated needs.

Inspection: It implies the activities such as measuring, examining, testing, grading one or more characteristics of a product or service comparing these with specified requirements to determine conformity.

Reliability: It is the ability of an item to perform a required function under stated conditions for a stated period of time.

Quality Policy: It is the overall quality intentions and direction of an organization as regards quality, as formally expressed by top management.

Quality Assurance: All those planned and systematic actions necessary to provide adequate confidence that a product or service will satisfy given requirements for quality.

Quality Control: The operational techniques and activities that are used to fulfill requirements for quality.

Quality System: The organizational structure, responsibilities, procedures, processes and resources for implementing quality management.

Quality Audit: A systematic and independent examination to determine whether quality activities and related results comply with the planned arrangements and whether these arrangements are implemented effectively and are suitable to achieve objectives.

Quality System Review: A formal evaluation by top management of the status and adequacy of the quality system in relation to quality policy and new objectives resulting from changing circumstances.

Specification: It implies the document that prescribes the requirements with which the product or service has to conform.

ISO: 9000 (IS 14000)

It gives guidelines for selection and use of quality management, quality assurance standards.

ISO: 9001:1987 (IS 14001:1988)

It is the model for quality assurance at all stages in design/development, production and servicing. ISO 9001 applies to industries that design, produce, install product and provide service after sales as per the requirements of the customers. Even after the installation, the supplier has to provide necessary services for maintenance of equipment for trouble free performance.

ISO 9002: 1987 (IS 14002: 1988)

It provides model for quality assurance in production and installation. In such cases the manufacturer gives his own design to meet the customers requirements and has to only prove the production process is capable of producing the product/equipment as per requirements of the customer and that the supplier can install the product/equipment at the customers premises satisfactorily. Civil structures, bridges etc. are the example. So, this model is applicable where assurance on quality is required only during production and upto satisfactory installation.

ISO: 9003: 1987 (IS: 14003: 1988)

It provides model for quality assurance in final inspection and test after the manufacture of the products who is only interested only in getting the product of desired quality as stated

by the supplier. For example, domestic appliances, petroleum products, automobile etc. fall under this category.

ISO 9004:1987 (IS: 14004:1991)

It provides model guidelines on quality management and quality system for non-contractual companies to build customer's confidence. The organizations have to take several integrated steps in managing all matters which have direct or indirect effect on its image to deliver the product/service of desired quality. These integrated efforts of the organization are the part of quality management.

ISO: 10011 (1990)

This series provide guidelines for auditing quality systems, ISO 10011-1 describes the role of auditors, their responsibilities, the elements of auditing, executing the audit and reporting etc. ISI 10011-2 deals with the qualification criteria for quality system auditors, their capabilities to perform the audit and their freedom from influence. ISO 10011-3 deals with establishment of audit function. IT states that management should establish a separate quality audit function outside the quality system implementation.

FEATURES OF ISO: 9000 SERIES OF STANDARDS

- (1) They are not new. The total system of quality is thrown open for verification by the customer and confidence is built in him that the organization is capable of delivering the products/services of desired quality.
- (2) These standards have been formulated by the persons involved in the actual work, who were conversant with the problem associated with quality.
- (3) These standards provide guidelines to the suppliers as well as manufacturers in respect of quality system.
- (4) It also defines the basic concepts and specifies the procedures that ensure the customers receive the product/services of their requirements.
- (5) These standards are user friendly, generic in nature and follow logic to make it understandable to the users.
- (6) These are not compulsory to follow by the organizations.

BENEFITS OF ISO: 9000

Both production as well as service companies benefits from ISO 9000 certification.

- These standards improve the confidence of the customer and the suppliers.
- This confidence level brings in a better perception of quality.
- It reduces the need for assessment of multiple buyers, thus avoids time and money spent on multiple inspection products.
- Adoption ISO: 9000 helps to enhance quality image of the organization and gives competitive edge over other organizations.
- It motivates the employee's and develops pride in them for achieving excellence.
- The down line effect of corrective and preventive actions contributes to increased profits for certified companies.

- The suppliers not having registered ISO: 9000 quality system may be required to pay higher insurance premium or insurance coverage.

ISO:9000 helps the organizations to

- Define clearly the need of the organization.
- Specify the right components, processes, tools and equipment for particular job.
- Distribute information to right people at right time.
- Achieve a system of management and control.
- It provides a framework for continuous improvement in quality.
- Once the ISO: 9000 has been adopted it automatically enables the organization control of its production quality and delivery schedules, cut waste and down the inspection time.
- It also enables organizations to offer the very best service to its customers.
- It also creates confidence for business interrelationships on account of ISO: 9000 certification.

Disadvantages of ISO: 9000

- It is very much demanding on recourses, time consuming and also involves considerable official work.
- Assessment and registration is also expensive.
- Unless carefully interpreted and planned, the system can become burdensome and expensive.
- The need to change workers attitude creates lot of problems to the management, since any change in the system is always opposed by the workers.

STEPS TO REGISTRATION ISO: 9000 SERIES

Every country adopts its own bodies for the implementation of ISO: 9000. The Bureau of Indian Standards (BIS) has introduced the quality system certification scheme according to IS: 14000 series of standards. These are identical to the internationally accepted ISO: 9000 series of standards of quality system. The following steps are required:

- (a) Management Commitment:** Top management has to take the decision for the implementation of ISO standards considering its importance to improve the quality of the products/services. The merits and demerits of ISO: 9000 must be taken into account before its implementation in the organization.
- (b) Prepare the Workmen for change:** It will be required to arrange training, seminars/ workshops on standards for the workers and their valuable suggestions must be considered for proper implementation of ISO series.
- (c) Selection of Model:** Appropriate model should be selected which suits the organization to achieve desired quality standards. However, guidelines for the same are provided in the standard itself.
- (d) Study of Model:** The selected model should be carefully studied to list down various elements required to be followed to satisfy the clause. This study should be carried out by expert senior members of the department.
- (e) Steering Committee:** Obtaining ISO: 9000 certification is a project in itself. Management may appoint different groups (2-4 members) to identify the activities to be undertaken

and to carry out survey of the existing practice of quality assurance system. A 'Ten step Master Plan' may be followed for easy and timely execution of major activities involved in ISI:9000 certification.

- (f) **Training Arrangements:** Training courses in ISO: 9000 standard would be required for the group coordinators and leaders in order to apprise them of their important role and contribution in the entire projects success.
- (g) **Check-list:** Prepare a check-list of the items which are always in practice but need change for the improvement and those which are not in practice.
- (h) **Preparation of Manual:** Prepare a quality manual and other documents incorporating all the elements of the selected model for fixing responsibilities to the members of the group with power, authority and responsibility.
- (i) **Preparation of Operation Manual:** Prepare procedure manual, operations manual and work instructions in short and in simple sentences so that they can be easily understood by all the members.
- (j) **Upgradation of Drawings and Specifications:** Old obsolete drawings and specifications should be withdrawn and new ones meeting customers requirements must be used to avoid confusion amongst the workers and operators. Feedback from the market will be useful to know the international standards to update the products and subsequently the drawings etc.
- (k) **Training of Employees:** Proper training to the shop floor workers/operators should be imparted with regards to ISO: 9000 standards. Since, the contribution of each and every employee is essential for the success of quality requirements. In-house training wherever possible must be made compulsory to all workers. However, some middle level and top level managers can be given specialized training outside the organization, who in turn will educate all other members in due course of time.
- (l) **Provision of Facilities:** A list of all the tools, equipment etc. should be prepared which will be required for implementation of ISO: 9000 standards. Any modification of the existing equipment which needs modification should be taken up at the appropriate time, so that work does not suffer because of poor facilities.
- (m) **Internal Audits:** A self audit to evaluate organizations documented quality assurance system is necessary to ensure that all practices followed and documented are available. This will determine the extent to which an organization is capable of meeting ISO: 9000 requirements.
- (n) **Corrective Actions:** Based on the internal audit corrective actions can be planned regarding the procedural requirements to meet the standards.
- (o) **Application for External Audit:** The next step is to apply to Bureau of Indian Standards or any other body for a trial audit for their recommendations.
- (p) **Implementation of Recommendations:** Implement the recommendations given by the certifying body and include them in quality manual and audit check list.
- (q) **Application for Registration:** Once the trial audit results are positive the organization is in the position to apply for registration to Bureau of Indian Standard on any other internationally recognized body. After the receipt of the application the Bureau will examine and point out the discrepancies if any and corrected application has to furnish for further processing.

- (r) **Grant of License:** Based on the findings of the assessment team and satisfactory report, license will be granted to the firm by appellate authority to use certification in letter heads, quality certificates etc. The certificate is normally valid for three years. But during this period also time to time audits are conducted to ensure that the documented quality system is being followed effectively. It follows PDCA cycle for corrective action.

Forms of Certification

Following are the three forms of certification:

- (a) **First Party:** A firm audits itself against ISO 9000 standards.
- (b) **Second Party:** Customers audit its supplies.
- (c) **Third Party:** A qualified national or international organization such as ISO or BIS are involved in certification process.

QUESTIONS

1. Explain what is ISO: 9000 quality system and why it is required.
2. Discuss the various levels of standardization in detail.
3. Explain about ISO: 9000 series standards briefly.
4. What are important features of ISO: 9000 series standard? Explain briefly.
5. What benefits can be achieved by adoption of ISO: 9000 standards?
6. Discuss various steps which are required for implementation of ISO:9000 standards.

**This page
intentionally left
blank**

Bibliography

1. Amstadter, B.L., Reliability Mathematics, McGraw Hill, New York, 1971.
2. Bazovsky, I., Reliability Theory Practice, Prentice Hall, Englewood Cliffs, 1965.
3. Cunningham, C.E., and Cox, W., Applied Maintainability Engineering, Wiley Inter Science Publication, John Wiley and Sons, New York, 1972.
4. Fides Guide 2004 Issue, A Reliability Methodology for Electronic Systems, September 2004.
5. Green, A.E., and A.J. Bourne, Reliability Technology, Wiley Inter Science, London, 1972.
6. J.E. Assenault and J.A. Roberts (eds.), Reliability and Maintainability of Electronic Systems, Computer Science Press Inc., Rockville Maryland, 1980.
7. Kolarik, W.J., Greeting Quality, Concepts, Systems, Strategies and Tools, New York McGraw Hill, 1995.
8. Lees. F.P., The Reliability of Instrumentation, Chemistry, and Industry, 1976.
9. Mishra R.C., Reliability and Maintenance Engineering, New Age International Publishers, 2006.
10. Mishra R.C.; and Soota. T., 'Modern Project Management', New Age International Publishers, New Delhi, 2005.
11. Shooman, M.L., Probabilistic Reliability Engineering Approach, McGraw Hill Pook Company, New York, 1968.
12. N.B. Fuqua, Reliability Engineering for Electronic Design, M. Dekker, 1987.
13. Prism, "System Reliability Assessment Software Tool", Reliability Analysis Centre (RAC), 1999.
14. Shooman, M.L., Probabilistic Reliability: An Engineering Approach, McGraw Hill, New York, 1968.
15. Smith, C.O., Introduction to Reliability Design, McGraw Hill, New York, 1976.
16. Smith, D.J., Reliability and Maintainability in Perspective, 3rd Edn., MacMillan, Basig Stoke, 1968.