

Chapter 21

Underground & Basement Shelters

When beginning the task of designing a fallout shelter, the prospective builder is faced with a number of different options. The builder must decide first which particular type of shelter envelope system or structural shell is the best suited to his needs. Once this important decision is made, the rest of the peripheral design considerations will start falling into place. To be or not to be underground—that is the question that Americans should be contemplating in this day and age. The choice is either a basement shelter or an underground shelter. There are many types of fallout shelters, and the type that is best for you can be determined only by your needs. There are a number of different fallout shelter options available.

Underground shelters give the maximum protection against radiation, heat and blast. Some of these options include: conventional reinforced concrete, concrete blocks, steel reinforced concrete domes and barrel vaults, metal culvert, used metal fuel tanks, metal

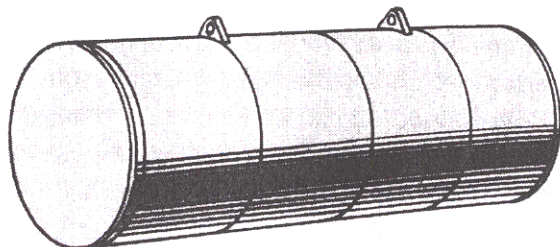

quonset structures, concrete sewer line pipe, pre-made fiberglass, and wood framed expedient shelters. Some people have even buried old school buses. When these below ground shelters are covered with at least three and preferably ten feet of earth, they provide an excellent protection factor against fallout radiation. Dirt is dirt-cheap and covering an underground shelter with 10 feet of earth is the least expensive way to achieve maximum shielding. If properly constructed, underground shelters offer good blast protection. This is especially true for the steel reinforced concrete domes and barrel vaults that have exceptional geometric strength characteristics due to their arch design. An underground shelter will give you a fighting chance in a worse case scenario.



No one system is going to be the best system in all environments, under all circumstances and considering all budgets. In fact, a shelter can contain combinations of a number of these options. The following section will examine the most basic shelter types with the intent of educating the reader so he can make his own decision.

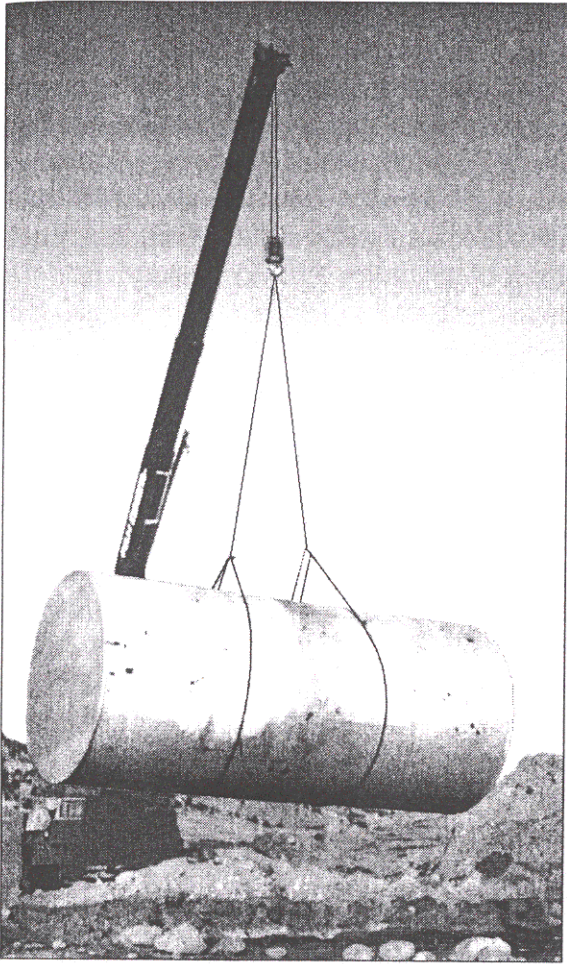

Used Fuel Tank

Fuel Tank Shelter

Advantages

If you are an accomplished welder, (or have someone in your shelter group who is) a steel tank shelter may be your best option. The advantage of fuel tank shelters is that used steel fuel tanks are relatively inexpensive to purchase. They can, to a limited extent, be internally outfitted in a shop before actual burial. Also, steel tanks can provide EMP (electromagnetic pulse) shielding. Steel tanks are generally watertight and can be used in areas where high water tables exist. It is much easier to weld and join together steel tanks than culvert.

If you are not an experienced welder and you intend to build a tank shelter, I suggest you research and purchase a good wire feed welder. Wire feed welders are much easier for novices to work with than arc welders. A Hobart wire feed welder costs about \$1,200 new.

Disadvantages

There are certain disadvantages to steel fuel tank shelters to consider. They are a confining space, generally limited to 10'6" diameter and require a floor system. Steel tanks have very little integral strength and are dependent on earth arching to remain structurally intact. Backfilling has to be done very carefully with optimum compaction.

Please note that cutting into a used fuel tank is an extremely dangerous operation. (Full precautions are given in the next chapter.) It can also be very difficult to clean the

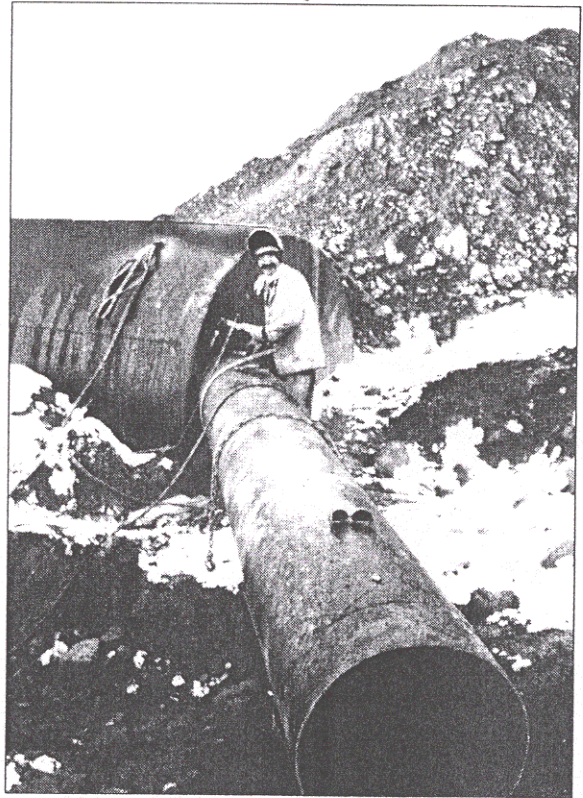

Welding - Tank Shelter

inside of a used diesel tank. Used fuel tanks can be rusted through in spots. New tanks are quite expensive.

Backfill and Compaction

One large shelter project, which I am personally involved in, successfully buried eleven steel tanks. I have friends who built tank shelter complexes which suffered severe deflection and shape distortion due to settling. This is usually a result of poor compaction during backfilling. The backfilling of steel tank shelters has to be done with optimum compaction of carefully selected or screened fill. Also, compaction cannot be accomplished when temperatures are freezing. When air temperatures are freezing, the application of pressure on the fill material does not produce compaction, but instead produces ice crystals in the soil. This may produce the false appearance of compaction, but when the spring thaw comes, further settling and deflection of the tank or culvert will result.

Steel tanks can also suffer severe deflection and shape distortion if someone drives a heavy loader, backhoe or bulldozer over, or too close to, a partially buried tank or culvert.

Any rock bigger than a softball that is buried within two feet of the tank, may even-

tually be forced by settling pressure directly against the tank and produce a deforming dent. Also large rocks, chunks of concrete, wood, or other debris buried next to the shelter when it is backfilled will cause differences in ground structure compression. This is a specific concern if the shelter is a blast shelter that is designed to withstand extreme over-pressure.

The ideal way to control compaction and prevent deforming is to take some special steps during excavation. The hole for the tank should be only dug down to the spring line or equator point of the tank. At this point, the remainder of the hole should be shaped to accommodate the rounded bottom of the fuel tank. The tank should then be placed in the hole and 3/4 inch minus gravel can be vibrated down around the sides into any unfilled voids. Instead of 3/4 inch minus gravel, a mud mixture can be slurried down around the underside of the tank. Such a slurry should be high in sand content and low in clay and the ground underneath needs to have good percolation. The danger with such a mud slurry is that the tank can float up out of the hole.

If you place a tank in a flat-bottomed hole, which has been dug to its total intended depth, it will be difficult or impossible to get adequate compaction on the underside of the tank.

If you are intending on internally outfitting a fuel tank before it is installed in the ground and back-filled, be aware that the tanks tend to flatten out on the bottom once the backfill settles. This is more pronounced with 12 ft. diameter tanks. The ramifications are that any braces used to support the floor or partition walls will bend and end up not being at their originally intended level or position.

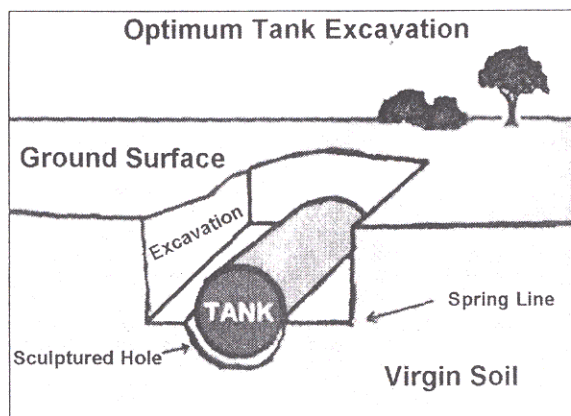

Also, pre-framed doors will end up out of square and not closing. The curved sidewalls of the tank, due to overhead pressure, will tend to expand away from pre-fitted partition walls leaving a gap. This same settling effect will put pressure on top of any pre-fitted partition walls and bow out the surface of the wall. Using great care during the backfill process will minimize these problems but not eliminate them.

Cleaning

As I previously mentioned, cleaning the inside of a used diesel tank can be a big and messy job. Used diesel tanks tend to have a fairly thick coating of hard, pasty residue on the inside walls and puddles of liquid diesel on the floor. We resorted to scraping the inside walls with a flat shovel to get this accumulated coating off. The liquid diesel can be easily soaked up with sawdust and then

shoveled into old feed sacks for disposal. Make sure you dispose of the material you clean out of the tank in an environmentally safe manner. Used gas tanks are generally fairly clean on the inside, but have a greater tendency to be rusted.

Arthur Robinson is the preeminent authority on shelters made from fuel tanks. He is the author of "The Fighting Chance" Newsletter. Plans can be purchased from him for fuel tank shelters. Contact the Oregon Institute of Science and Medicine, P.O. Box 1279, Cave Junction, Oregon 97523.

Sharon Packer, with the Civil Defense Volunteers of Utah, has a 160-page booklet on aspects of shelter building that includes an excellent section on steel tank and culvert shelters. This booklet is \$20 postage paid and

Steel Fuel Tank Sizes, Capacity and Specification Data

Capacity (Gallons)	Tank Diameter	Tank Length	Overall Length	Wall Thickness	Weight (Pounds)
4,000	5'4"	24'0"	24'10"	.313"	5,680
4,000	7'0"	14'0"	14'10"	.313"	4,910
4,000	8'0"	10'8"	12'6"	.384"	5,840
5,000	8'0"	13'4"	14'2"	.384"	6,920
6,000	6'0"	28'5"	29'3"	.384"	8,000
6,000	8'0"	16'0"	16'10"	.384"	9,600
8,000	8'0"	21'4"	22'2"	.384"	10,120
10,000	10'6"	15'6"	16'4"	.429"	12,200
10,000	8'0"	27'0"	27'10"	.384"	12,220
12,000	8'0"	32'0"	32'10"	.429"	16,000
12,000	10'6"	18'6"	19'4"	.429"	13,900
15,000	8'0"	40'0"	40'10"	.492"	22,400
15,000	10'6"	23'4"	24'2"	.492"	19,120
20,000	10'6"	31'0"	31'10"	.492"	24,200
25,000	10'6"	38'9"	39'7"	.554"	33,300
25,000	12'0"	30'0"	30'10"	.625"	34,700
30,000	10'6"	46'6"	47'4"	.554"	39,000
30,000	12'0"	36'0"	37'10"	.625"	40,800

can be obtained by contacting her at (435) 657-2641.

Cold Formed Steel Rib System

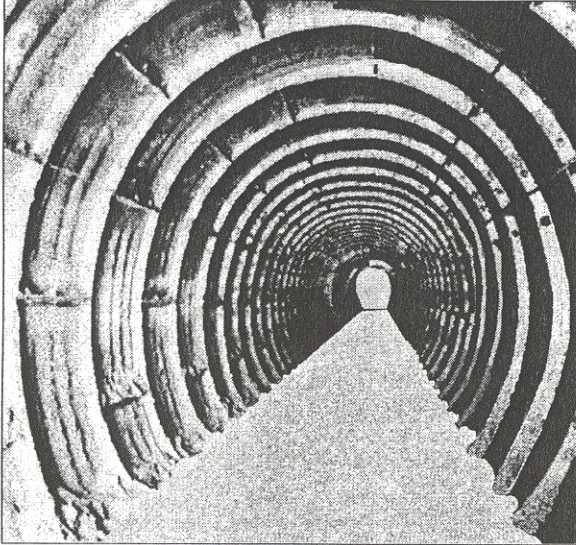

A company named American Commercial makes cold-formed panel sections for underground support. This system is used around the world for ceiling supports in tunnels and mines. These curved panels bolt together to make a steel barrel vault form.

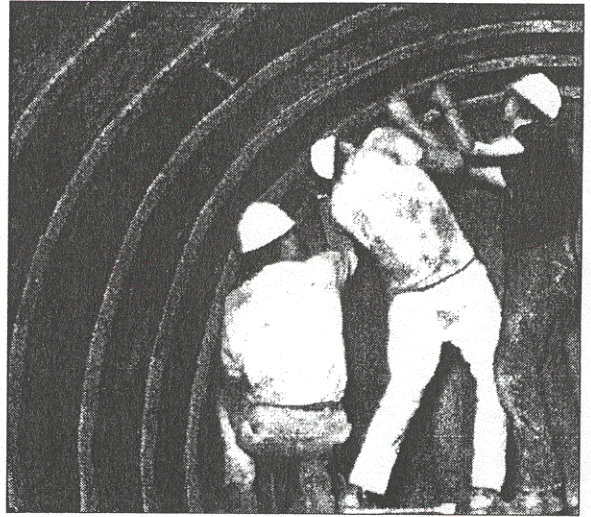

Once the barrel vault is completed (refer to the Newhouse system for more information), the panels can be unbolted from the inside and reused for another project. American Commercial is located in Louisville, KY and they can be contacted by telephone at: (540) 466-2743 or on the internet at: <<http://www.americancommercial.com>>.

Shipping Containers

I have been questioned about the feasibility of using shipping containers for a shelter. I'm sure you have seen these rectangular cargo containers single and double stacked

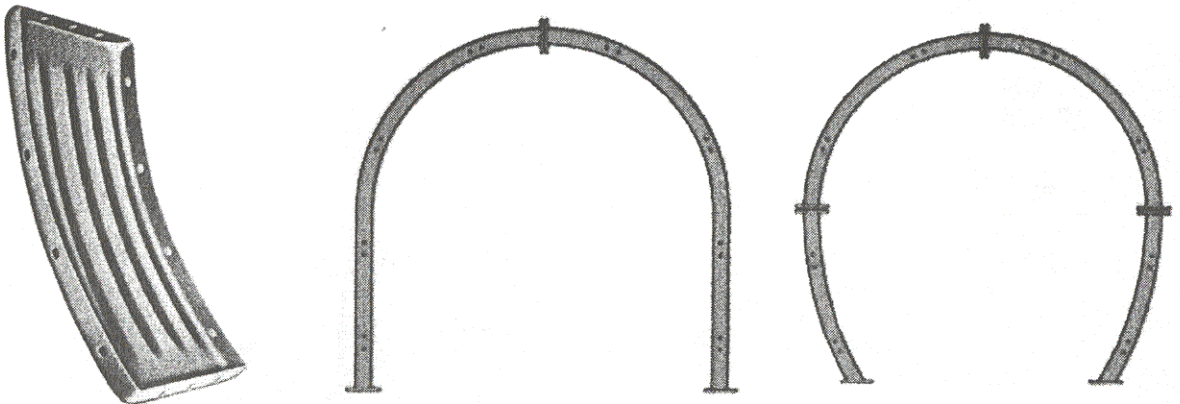

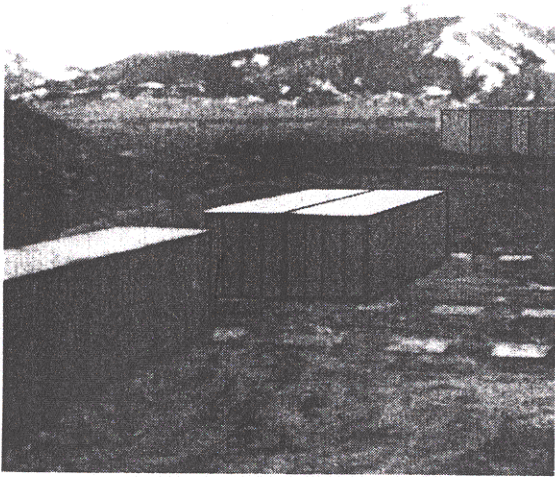
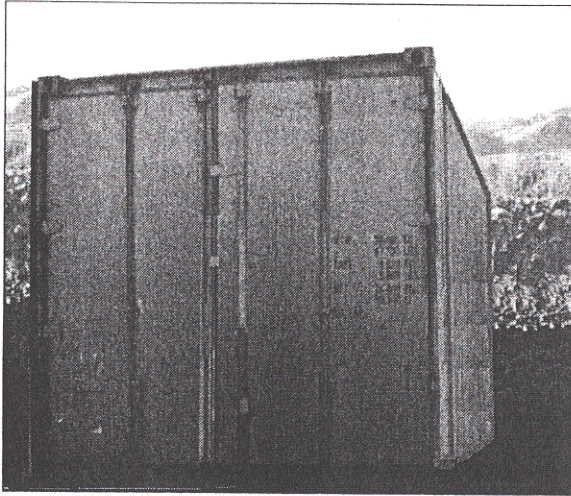

on railroad flat cars moving down the railroad tracks from time to time. These are referred to as sea containers. They are used for transporting freight on ships. These containers are many times stacked seven high on the decks of ships loaded with cargo. If you live near a major seaport like Seattle, Long Beach, Los Angeles, New York, Boston, etc. you can find these containers which have been retired from service for various reasons.

Advantages

Shipping containers have very useable space on the inside. The containers themselves are 8 ft. high, 8 ft. wide and come in lengths of either 20 or 40 feet. If they are in good condition, they will have watertight ceilings and walls. The floors are made of plank material.

Disadvantages

Even though sea containers can be stacked seven containers high, one on top of the other, they have very little overall strength. All of a sea container's strength is in its heavily reinforced corners. The author has been involved in burying numerous sea containers and witnessed a number of other people attempting to do the same. The key to success when burying sea containers is reinforcing. Experience has shown that unreinforced sea containers buckle and collapse if dirt is loaded on top of them. I have also seen sides buckle inward from the weight of back-filled dirt pressing sideways against the walls.

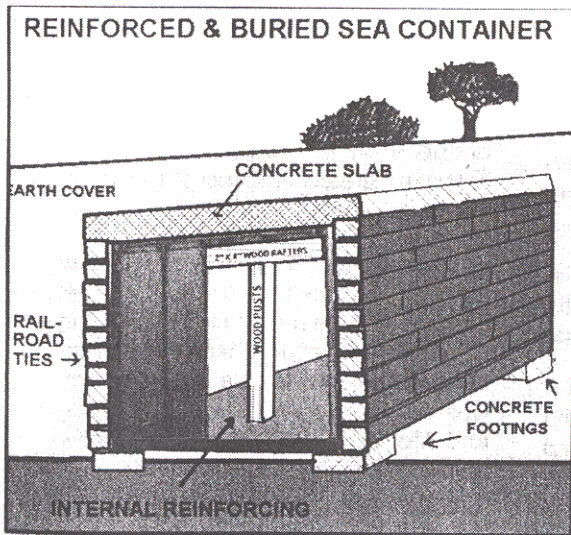

The sea containers we buried did not buckle or collapse because we went to considerable effort to reinforce them. First, we reinforced the containers from the inside. This was done by installing vertical posts that supported horizontal crosspieces. This is similar to the way conventional mining operations shore up a tunnel. Then we built railroad tie

walls, in a Lincoln log fashion, all the way around the exterior walls of the sea container and snug to them. These railroad tie walls went from the bottom of the container wall up to the roof. Our next step was to pour a reinforced concrete slab over the top of the container's roof. This slab overlapped onto the railroad ties that formed a perimeter around the edges of the sea container's roof. We then waterproofed the slab and covered it over with dirt.

In our case, we are using the containers, not for shelters, but for underground storage. One other thing we did which added to our success was to place the four corners of the containers on concrete footings. The logic behind this is that without footings the containers would settle once backfilled. As a result they would tend to tweak or twist slightly out of shape which would make the doors not open or close properly.

Buyer beware. Personally inspect any container you are thinking of purchasing. Make sure they are not rusted out and that the doors work.

Culvert Shelters

Advantages

Shelters made from steel culvert can usually be installed and backfilled quicker than with concrete shelters. In other words, the excavation hole is open for a shorter time. This can be an advantage where confidentiality is a concern. Culvert is stronger than steel fuel tanks, and if the entryways and penetrations are properly configured, culvert will shield against electromagnetic pulse. It is a somewhat flexible system that can be extended with additional lengths, as more capacity is needed.

Disadvantages

Culvert shelters are a confining space, limited in width to 13' diameter. Culvert has minimal integral strength and is dependent on earth-arching. However, culvert is stronger than a steel fuel tank even though it is made of a thinner gauge steel. Culvert's corrugated ribs greatly enhance its structural characteristics. Culvert, due to its spiral ribs and galvanized coating, is not as easy to weld and join together as steel tanks.

The initial cost of purchasing steel culvert is much greater than picking up a used fuel tank, but once you consider the cost and hazard of cutting into, cleaning, painting and re-coating the outside of used tanks, new culvert ends up comparable in price.

Backfill

Rocks backfilled too close to the outside surface of a buried fuel tank produce large dents on the inside and hitting them with the bucket of a backhoe also produces large dents. This is not the case with culvert. None of the culvert shelters I have seen have shown any signs of point loading dents caused by rocks being backfilled too close to the outside surface of the culvert. Also, experience has shown that culvert does not buckle and dent when bumped by a backhoe bucket.

Backfilling has to be done very carefully with optimum compaction. There have been some serious instances of deflection as a result of the settling of the earth that was backfilled over the culvert. As we previously discussed concerning steel fuel tanks, compaction cannot be accomplished when temperatures are freezing. The ideal way to control compaction and prevent deforming is to take some special steps during excavation. Please see the previous discussion at the

Culvert Shelter

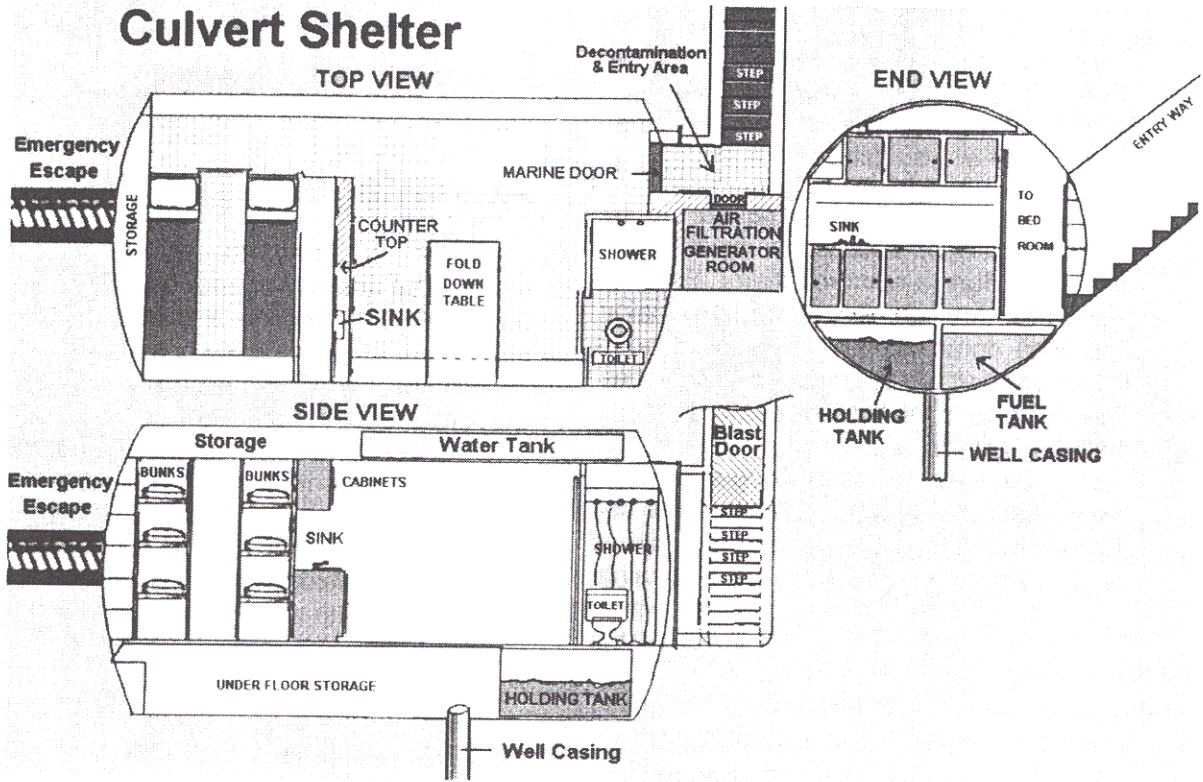

Culvert Shelter

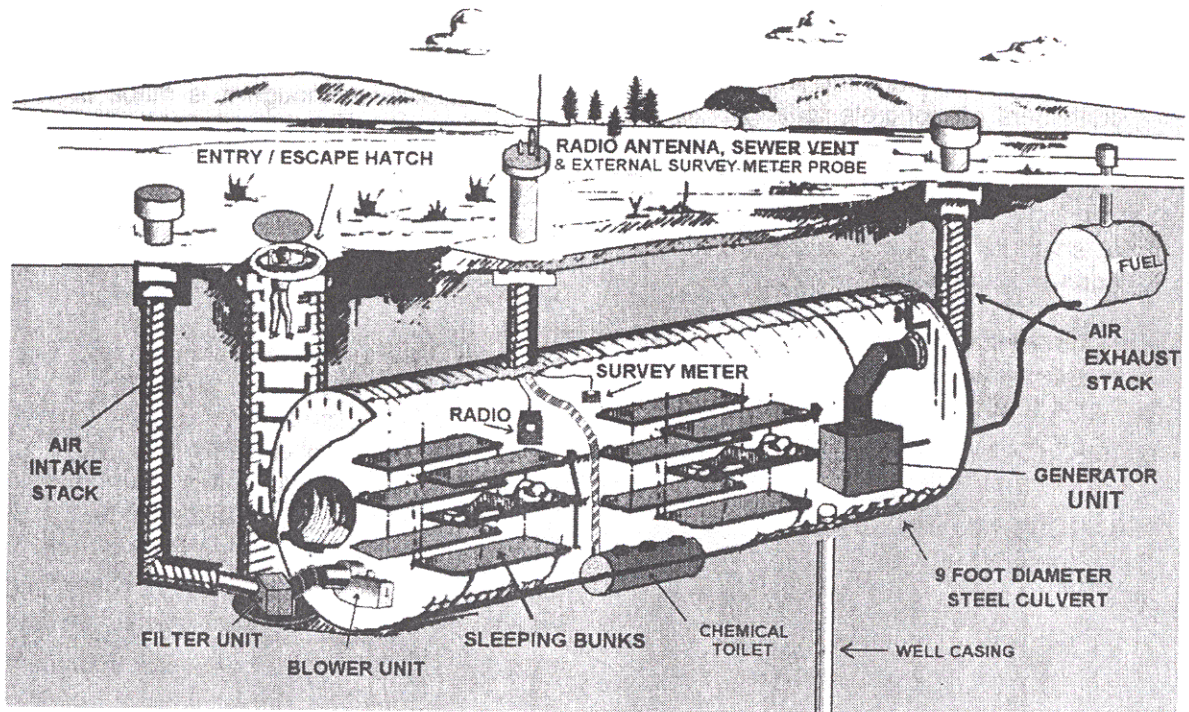

beginning of this chapter under Tank Shelters, Backfill and Compaction.

If you place a culvert in a flat-bottomed hole which has been dug to its total intended depth, it will be difficult or impossible to get adequate compaction on the underside of the culvert.

Even with the best compaction and backfill, culvert manufacturers say you should expect about 10% deflection. This means that any internal doorways and wall structures that are fitted tightly to the inside curve of the culvert will eventually become compressed. Cabinets fitted to the original inside curved surface of the culvert will displace themselves from the walls when the culvert squats due to settling and changes its internal curved shape. The punch line is either wait a year or two after backfill and subsequent settling to internally outfit your culvert shelter, (I do not recommend such a delay), internally outfit the shelter without wall and ceiling attachments which would be effected by the settling or build a steel reinforced concrete shelter.

Steel Quonset Shelters

Advantages

Steel quonset shelters allow for larger spans than steel culvert and have more usable internal space. The military has been using these for munition bunkers for many years.

Disadvantages

Steel quonset shelters have very little integral strength and are dependent on earth arching. Backfilling a steel quonset has to be done very carefully with optimum compaction. End walls are made of steel reinforced concrete or masonry block. In the event of an overpressure, there is a possibi-

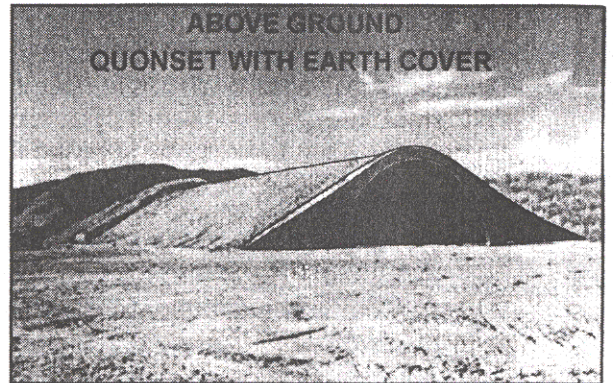
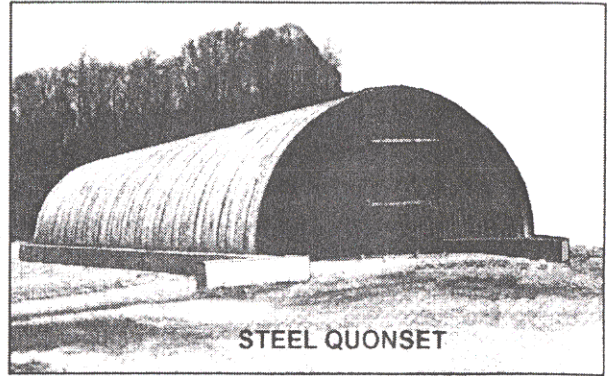

ty of point loading on the structure where the flexing steel meets the rigid wall. Such point loading can result in buckling and structural failure.

In the past, the military has had considerable water leaking problems with its steel quonset ammunition bunkers. The problem was so bad that in some instances the Army made PVC tents inside the quonsets to keep the leaking moisture off the munitions. This problem has now been resolved by spraying the exterior of the quonset with polyurethane foam. Steel quonsets cannot be used in areas with high water tables.

For information on buriable steel quonset structures contact Arch Technology Corporation, 11N024 Rippburger Road, P.O. Box 70006, Plato Center, IL 60170; (847) 464-5656 or (800) 222-5656; fax: (847) 464-4661; e-mail: wonderbuilding@aol.com; www.archtechnology.com.

Steel Quonset Shelter

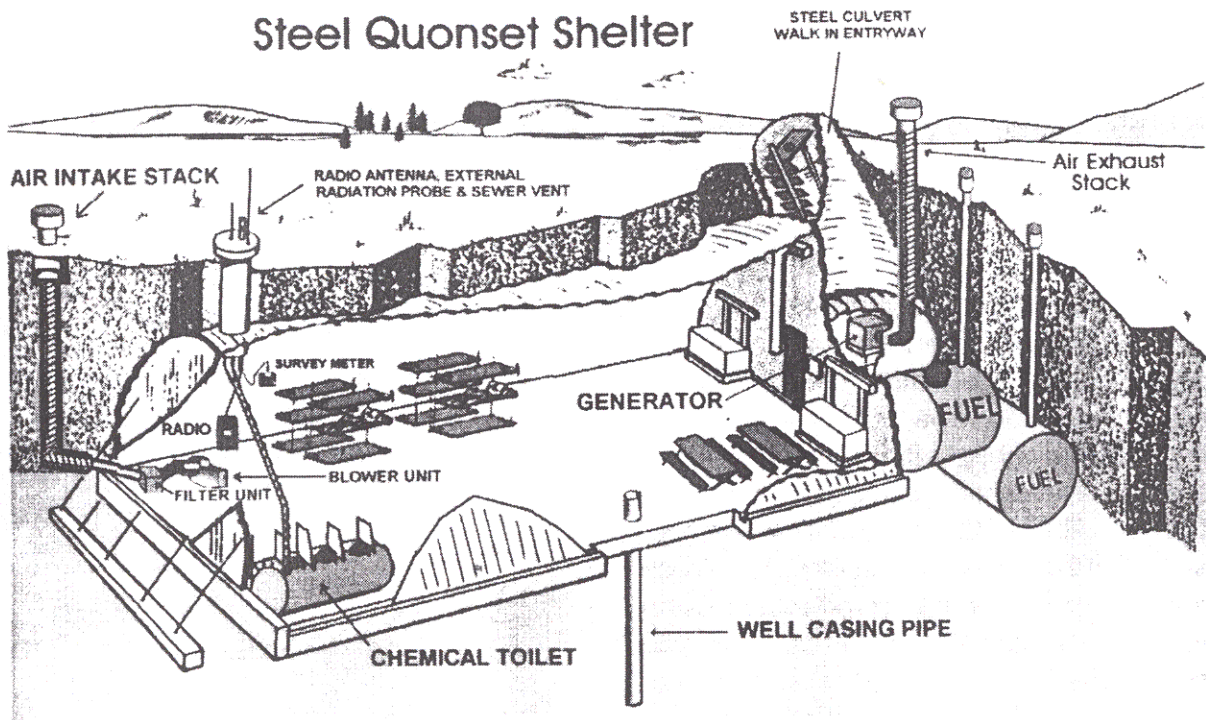

Pre-made Fiberglass

Advantages

The great feature about this system is that it comes completely internally outfitted from the factory. All of the life support systems are pre-made at the factory. This includes air filtration, water storage, entryway, sewage system, power and observation tower. They can be used in areas where a high water table exists, and often can be ordered, delivered and installed faster than building a comparable shelter from scratch. The advantages to the single-family shelter are that fewer people know about the shelter and ideally the project gets done faster. Another advantage to the single-family approach is that management and decision making are more simplified.

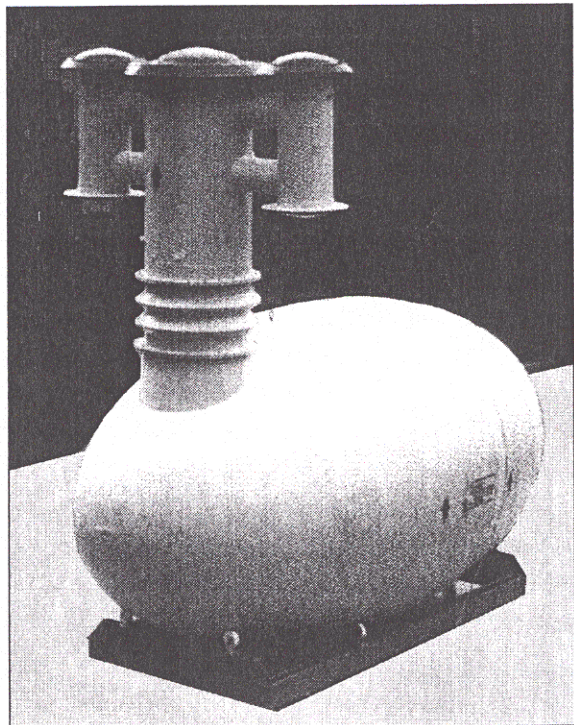

Disadvantages

This system is expensive. It is a confining space and it is generally not conducive to community application. Molded fiberglass shelters have very little integral strength and are dependent on earth arching. Like steel tanks and culverts, backfilling has to be done very carefully with optimum compaction. It does not shield EMP.

Like any other one-room shelter, this system has minimal personal privacy. These shelters have only one entryway. The advantages of two entryways are covered in the next chapter.

For more information on Radius Defense shelters contact Bill Eckhoff at Kleen Air Technologies, Inc., P.O. Box 4145, Frisco, CO 80443, (970) 668-0219, Fax (719) 836-1807, E-mail: katinc@amigo.net, www.undergroundshelter.com.

Conventional Steel Reinforced Concrete Shelters

This type of shelter is basically a concrete box. It is formed up with standard basement wall forms. The roof is made of a thick steel reinforced slab.

Advantages

Most local masonry contractors are familiar with the concepts involved in building a belowground conventional steel reinforced concrete structure. This system does not derive its strength from earth arching and the backfilling can be done without any particular care.

Disadvantages

Conventional steel reinforced concrete shelters require massive steel reinforced

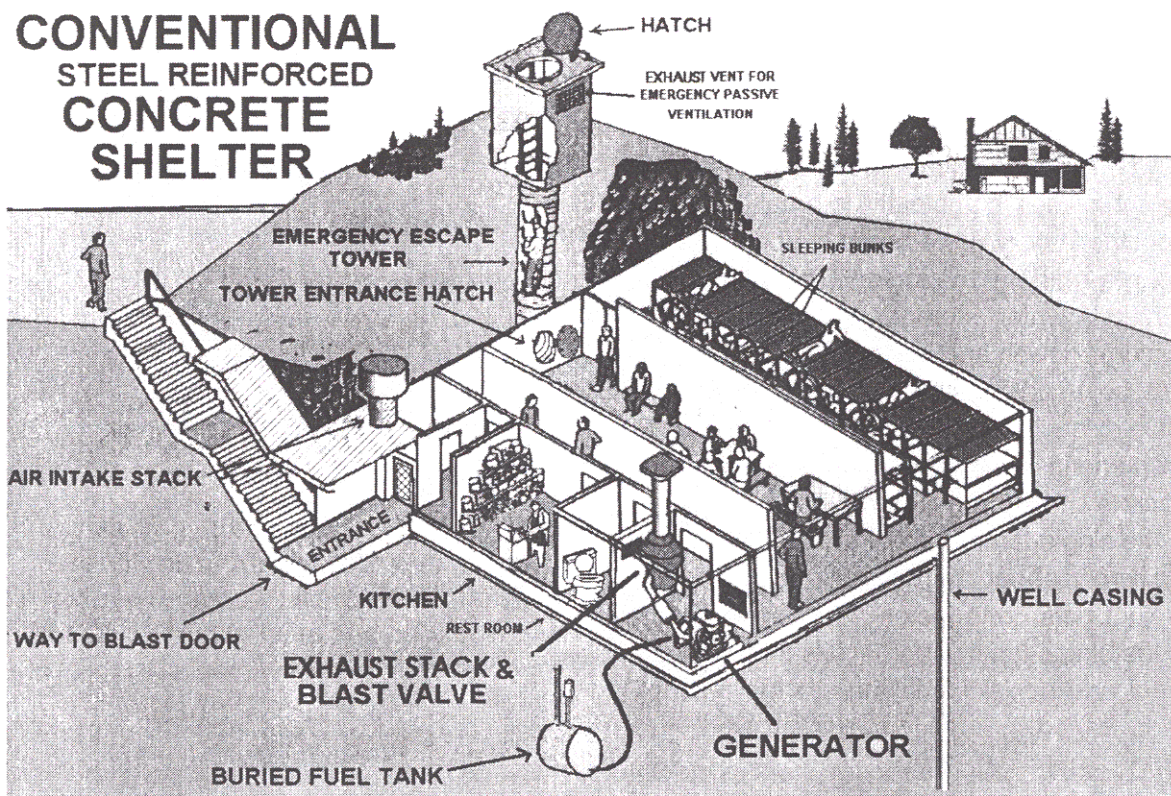

concrete slabs to span ceilings and support the earth cover on top of the shelter. Concrete slab ceilings can only free-span limited distances without the addition of vertical supports. Concrete shelters do not provide EMP shielding and are not usable in areas with high water tables.

Thin Shell Concrete Technology

This category of shelters includes steel reinforced concrete domes, barrel vaults and donut shaped structures. All of these structures are different shapes of the same technology. The author has considerable experience with this type of shelter system.

I organized a project in which our group built a barrel vault that was 32 feet wide and 122 feet long with three floor levels. As far as we know, this is the largest underground concrete dome-type shelter ever built.

Advantages

The advantages of thin shell concrete domes and arches are that they facilitate large structures with wide spans. This system capitalizes on the natural geometric strength of an arch. The resulting structure is a very strong shell that is not dependent on earth arching for its strength. Thus, no particular care is needed when backfilling these shelters.

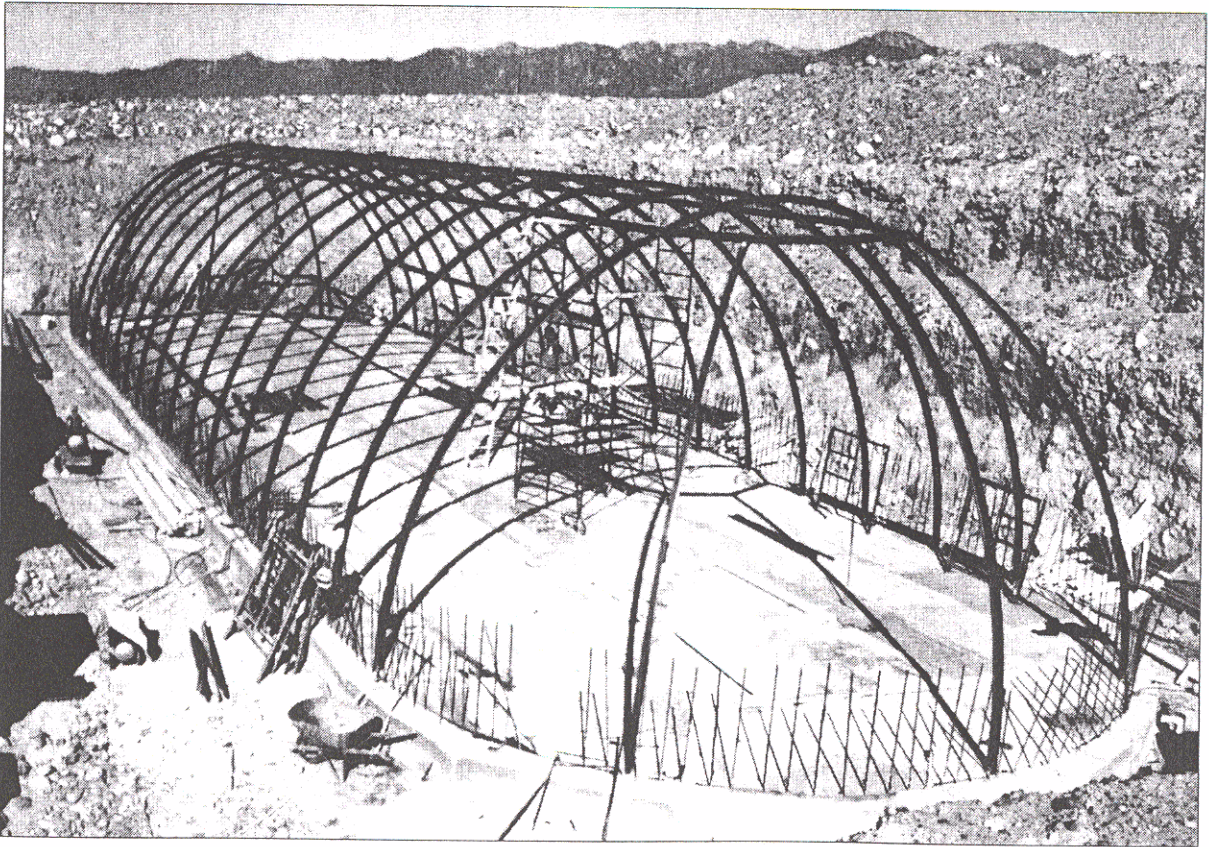

Framework for Concrete Dome

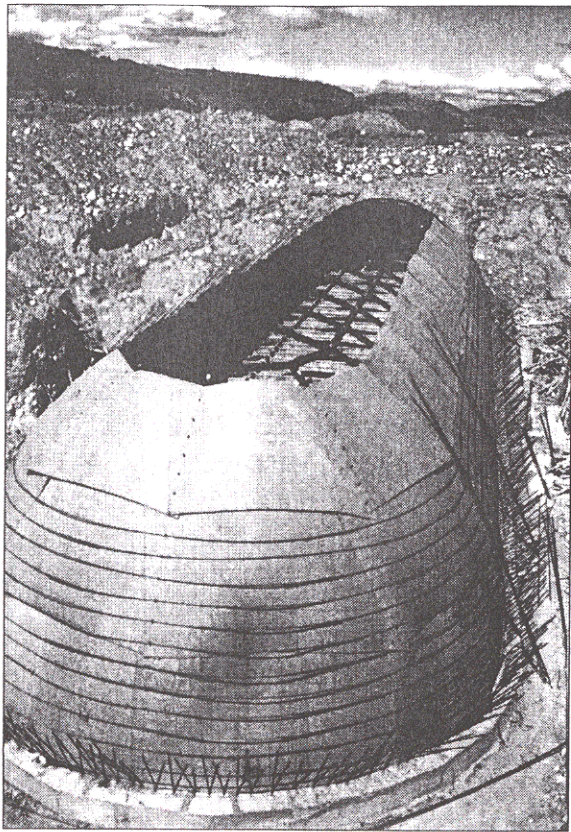

Disadvantages

The disadvantages of this particular system are that it does not shield EMP and it is not usable for areas with high water tables. Concrete is applied with shotcrete equipment. Shotcreting is expensive and takes substantial amounts of manpower to accomplish. The kits for the shell of these structures are fairly expensive.

The large concrete barrel vault shelter shown in the pictures was built by the author and his friends. The shell is made from a kit supplied by Earth Systems, Inc. (E.S.I.). This company is no longer in business. There are at least two other companies in the United States which make steel reinforced concrete dome kits.

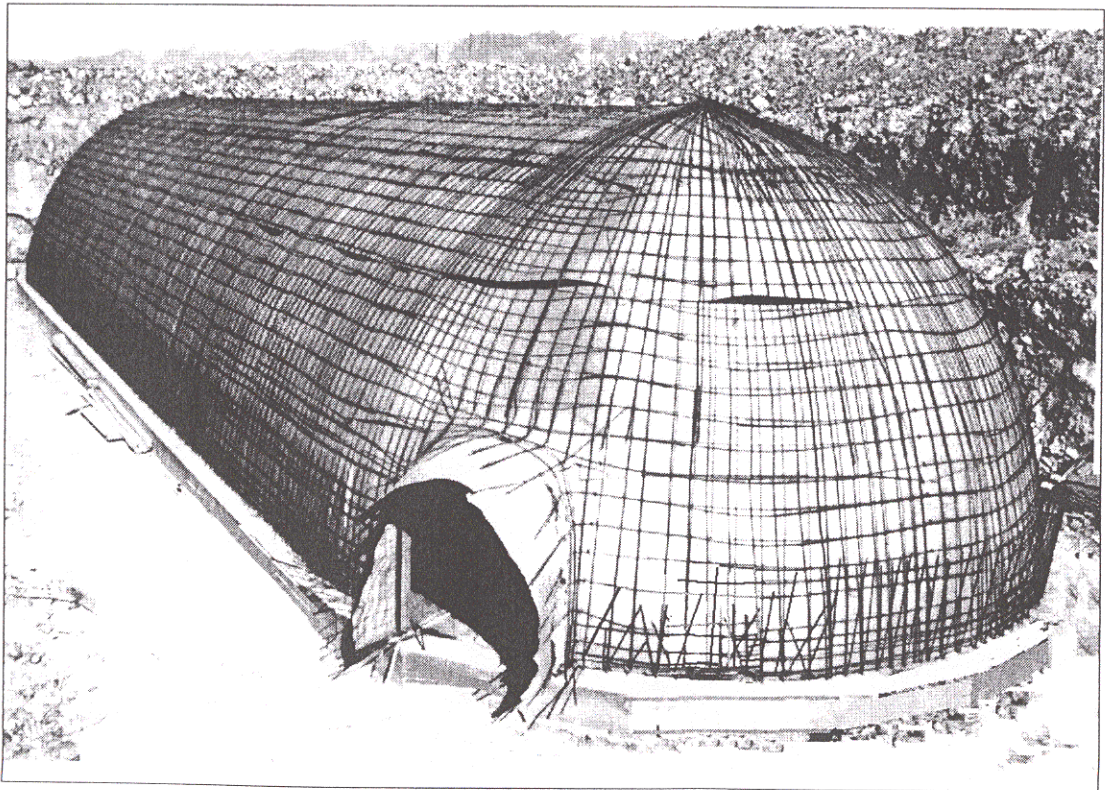

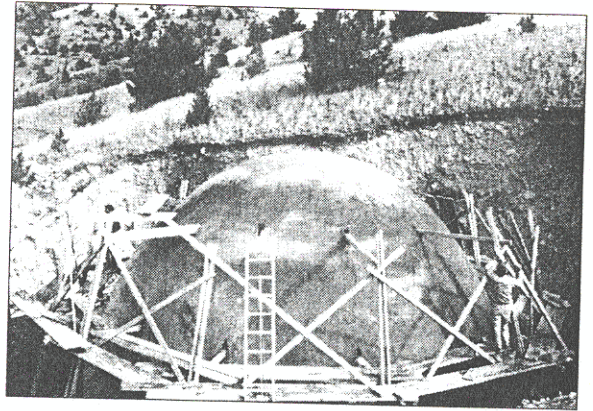
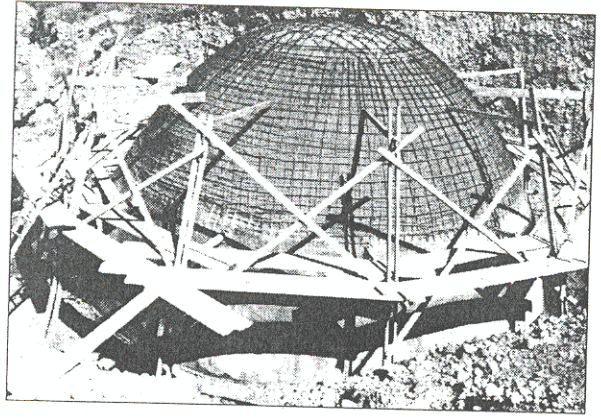
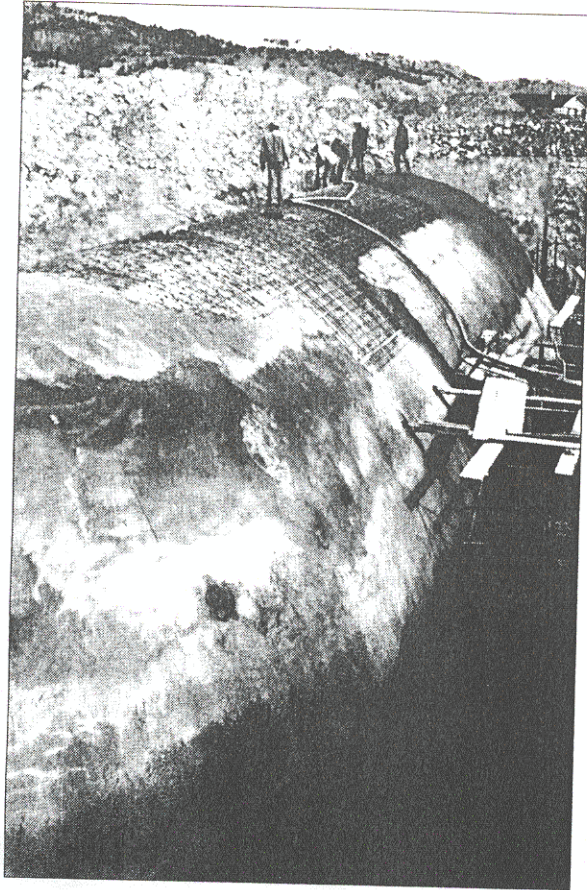

Terra-Dome

The Terra Dome is another steel reinforced concrete dome-like system. The Terra-Dome system uses aluminum vertical wall forms and a fiberglass roof form. Waterproofing for this system is applied to the outer concrete surface.

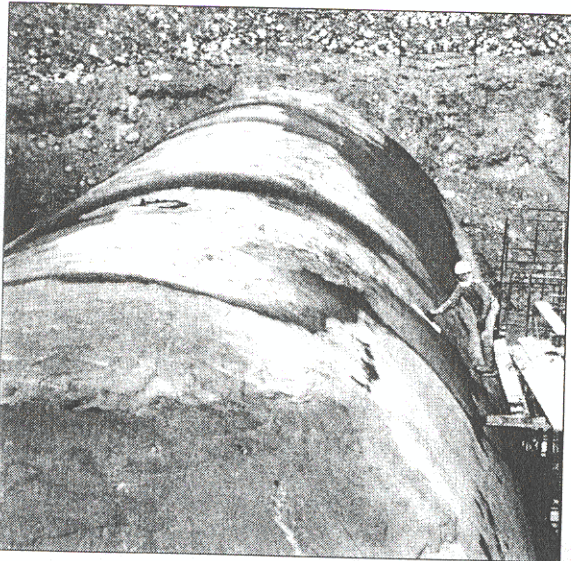

Terra-Dome Modules During Construction

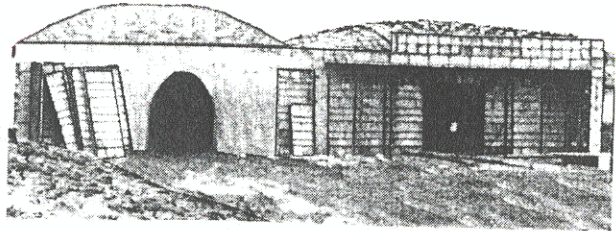

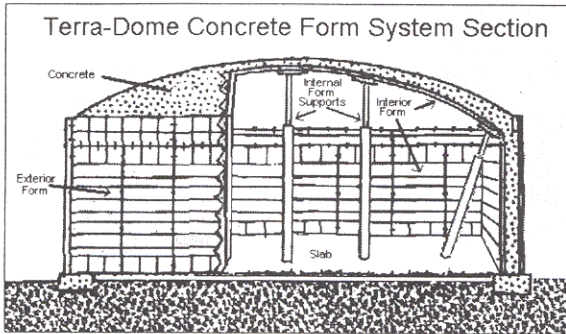
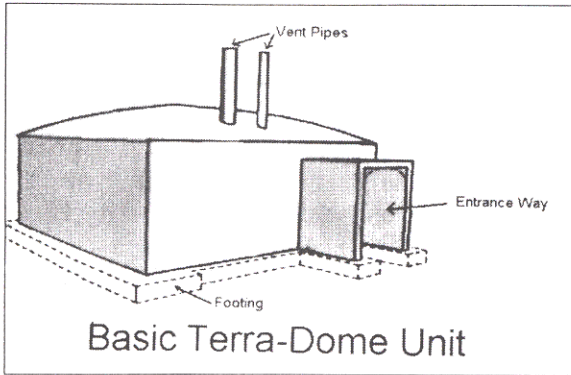

Advantages

This system has the same advantages as other thin-shell concrete domes. There are several other advantages. The Terra Dome system is not insulated. It is better for underground shelters to be uninsulated to facilitate the conduction of heat buildup in the shelter to the surrounding earth cover. The shell form system can be reused (this is not necessarily an advantage because it belongs to and goes back to Terra-Dome.) Terra-Dome is constructed on-site by Terra-Dome employees who know what they are doing and can complete the shell of the structure in three days, once all site preparation is completed. This is the big advantage to Terra-Dome, if you have the money. Terra-Dome is potentially the quickest one you can get built. This is a definite option for those who do not want to do the work themselves.

Disadvantages

One minor disadvantage is that this system, like the E.S.I. system, needs to be waterproofed. Terra-Dome is not a do-it-yourself kit system and thus is relatively expensive. This system is not a pure dome shape and thus does not have the same geometric strength advantages. Thus the Terra-Dome would not be usable for a blast type shelter without structural reengineering and reinforcing.

For Terra-Dome information and prices write to Terra-Dome, 8908 S. Shroul Rd., Grain Valley, Missouri 64029, (800) 481-3663; www.terra-dome.com.

Monolithic System

The Monolithic system involves inflating a balloon form and then spraying urethane foam on the inside surface of this form. Steel rebar is then attached to the resulting inside surface and concrete is sprayed over the rebar, again from the inside of the balloon form. The resulting product is a steel reinforced dome, with foam insulation and the original form balloon becomes a fixed waterproofing barrier. The newest product from Monolithic is a small concrete pod like dome that is pre-made and deliverable by truck. This small dome can be either buried or used above ground.

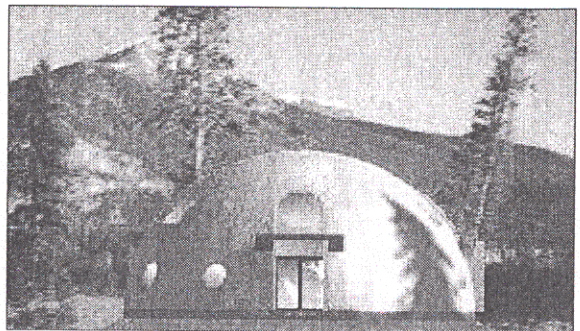

Advantages

This system has the same advantages as other thin-shell concrete domes. Another advantage to the Monolithic system is that it has built-in waterproofing.

Disadvantages

The disadvantages of this particular system are that the kit is relatively expensive and the expensive balloon form can't be reused for another project. Another potential disadvantage of this system is the foam insulation. The foam insulation is probably an asset for a sub-earth home or an above ground structure. If, on the other hand, you are building an underground shelter, the foam insulation will restrict the conduction of heat from the inside of the shelter to the surrounding earth cover. Heat build-up is a potentially serious problem in crowded underground shelters, as we discuss in the chapter on Air Supply.

Prices and information on the Monolithic Dome system can be obtained by contacting Rocky Mountain Dome Co. HCR 85, Box 170M, Bonners Ferry, ID 83805, (208) 267-8596, Fax (208) 267-1037.

Home Grown Options

The final option in steel reinforced concrete domes and barrel vaults are the home-grown versions. This option includes systems that involve making your own form and thus eliminating the expensive kit cost.

Grenier - Barbier System

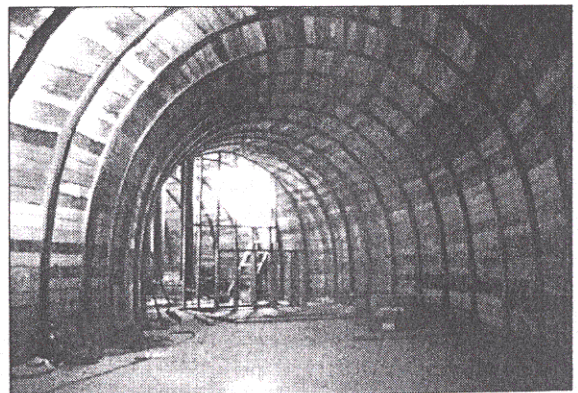
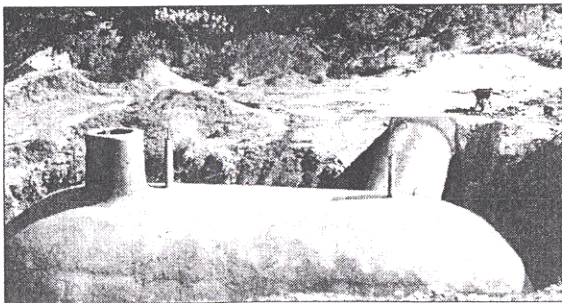
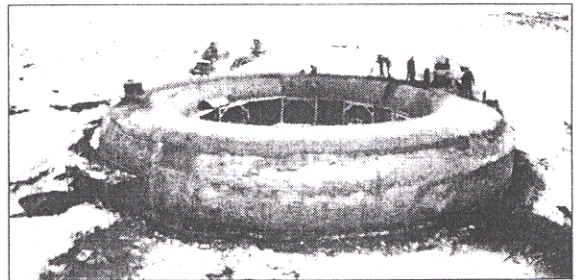
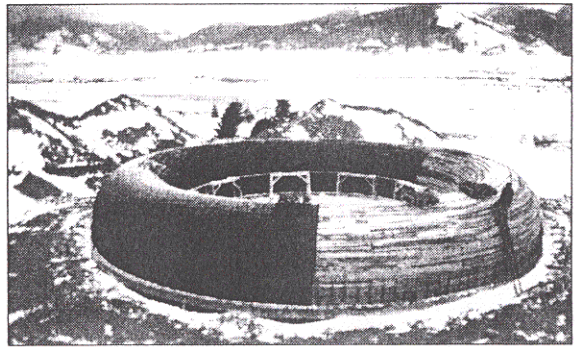
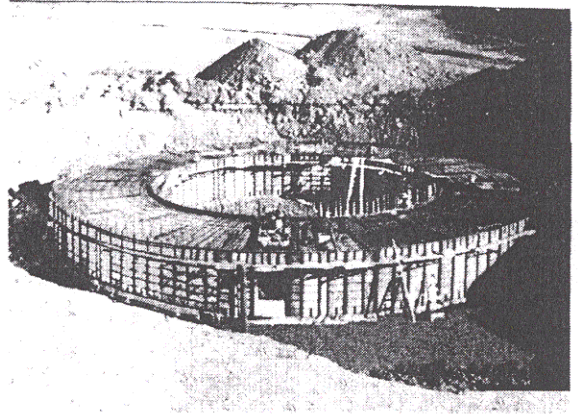

RIB WORK COMPLETED GRENIER - BARBIER SHELTER

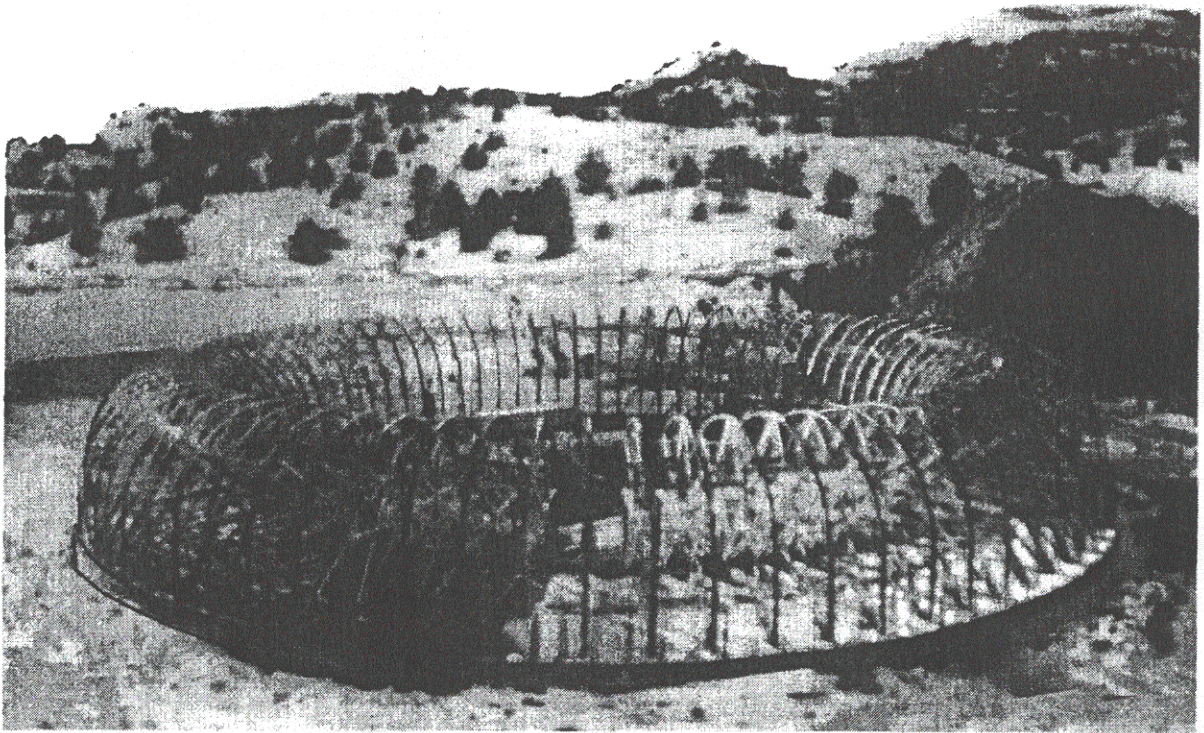

Grenier - Barbier System

The first system in the home brewed category is what I call the Grenier - Barbier system. Mark Grenier is a close friend and a master builder. He built a donut arch system designed by Marcel Barbier, who is a well-known engineer in the civil defense field. The form was made of redwood boards that were steamed and bent over a wooden rib system. The outer surface had rebar tied over it and concrete applied. The resulting structure was then waterproofed and backfilled.

Advantages

This system has the same advantages as thin-shell concrete domes and barrel vaults. Other advantages to this system are that there are no kit costs and the interior surface

is beautifully finished redwood. For a larger shelter, the donut shape has the optimum geometric shape.

Disadvantages

The disadvantage with this system is that the process of steaming and bending redwood boards is very labor intensive and the form is not reusable.

Newhouse System

Another home brewed system is what I call the Newhouse system. This system was devised by a friend of mine named Dave Newhouse. Dave built tract homes for about 30 years before he started building underground shelters.

EARTH COVER

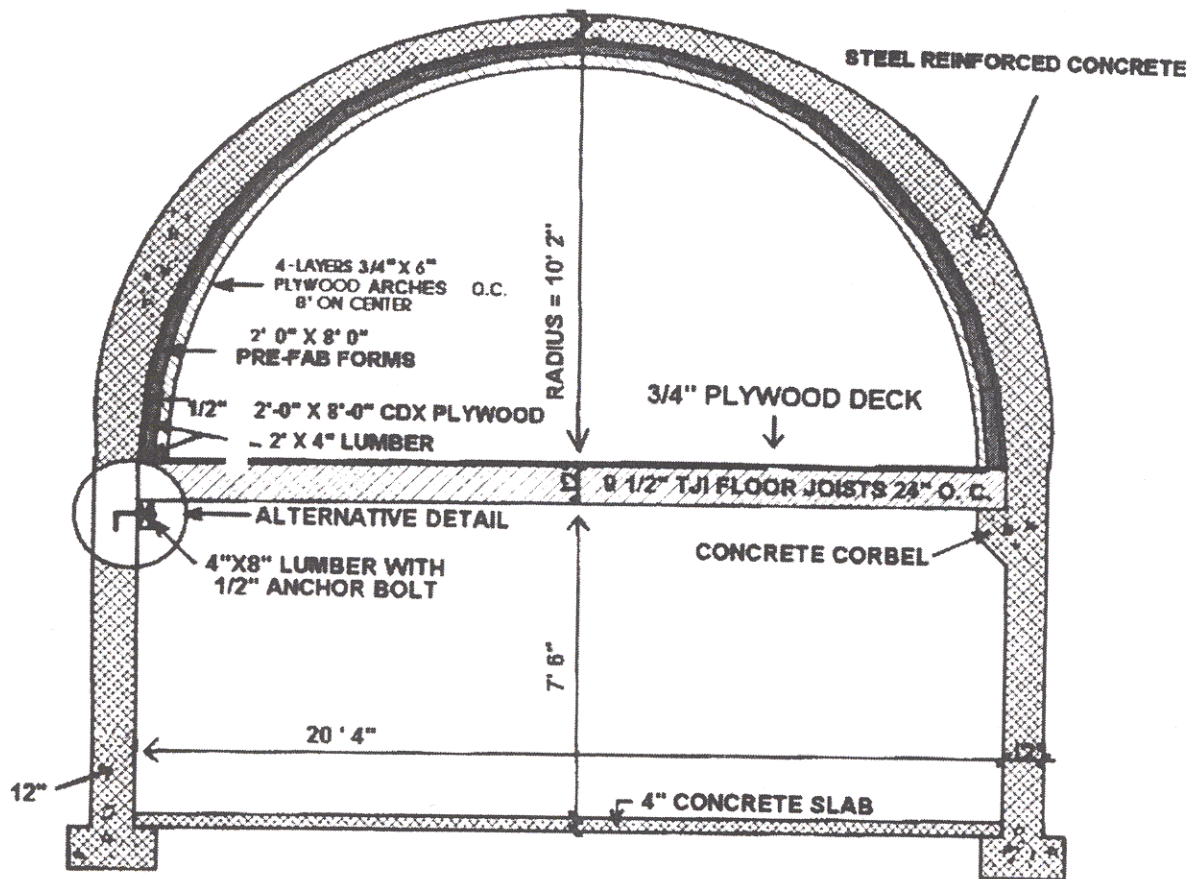

After building concrete dome systems from expensive E.S.I. kits, Dave and I started contemplating how we would do it if we had to do it over again. The whole idea was to get away from the expensive kit and the labor-

intensive shotcreting. Dave came up with a new system that involved making your own form system with plywood and two-by-fours.

Advantages

The forms for this system can be reused over and over again. Shotcrete equipment is not needed for the Newhouse system. The concrete can be applied to the structure by a concrete pump truck. This reduces the labor by about two thirds, and the pump truck costs a fraction of what shotcrete application costs. As I mentioned earlier, for an E.S.I. system you need to apply the concrete with shotcrete equipment.

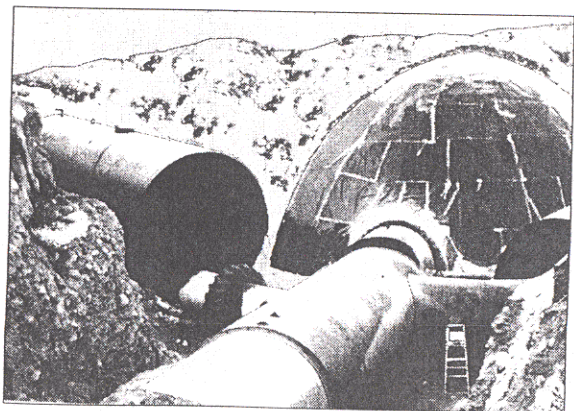

Newhouse System Concrete Form Detail

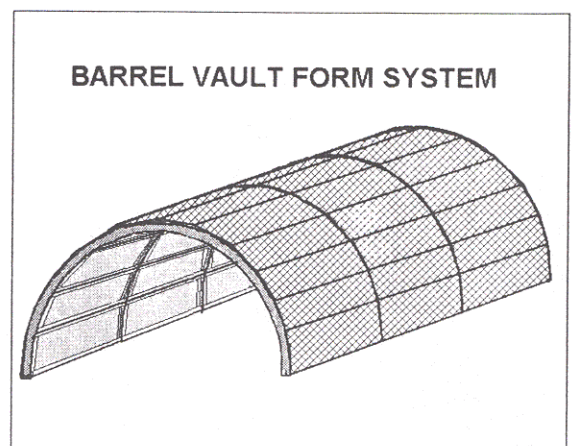
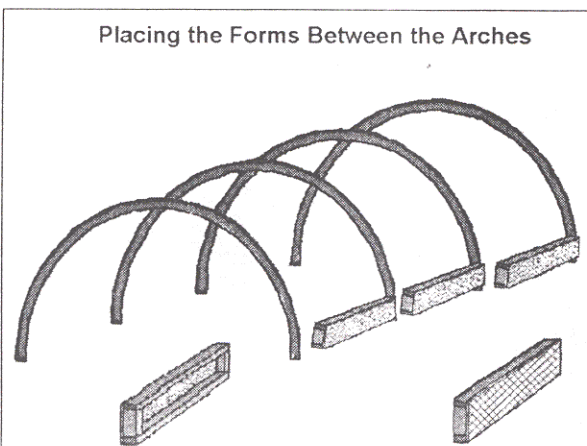
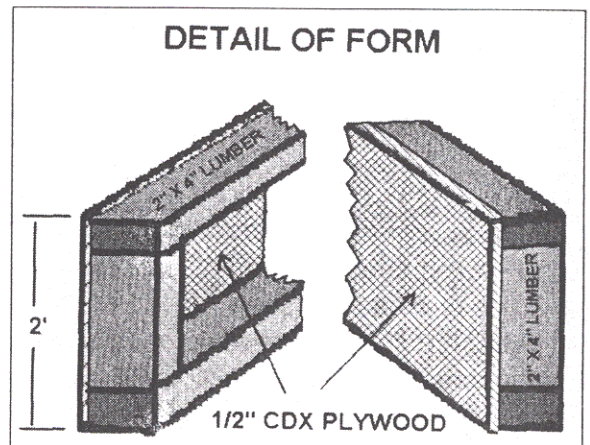
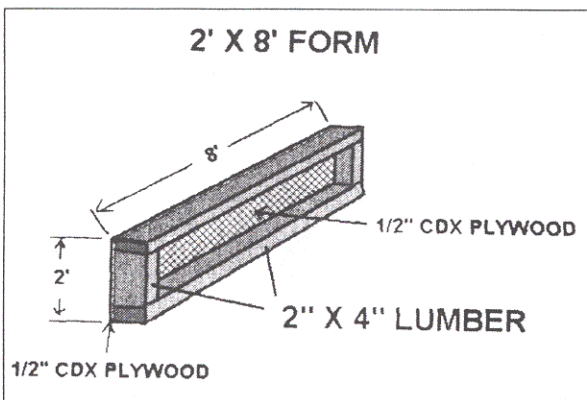
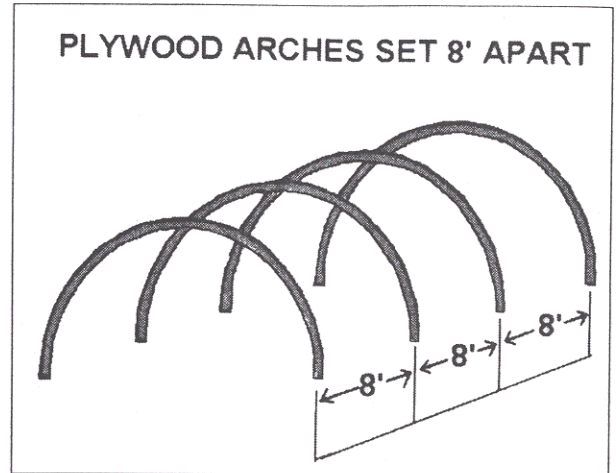
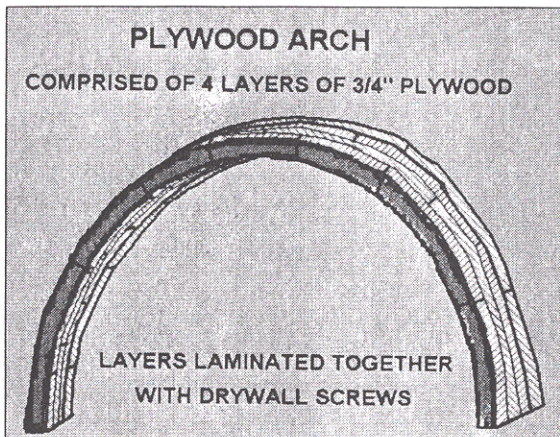

Disadvantages

The disadvantages of the Newhouse system are that it does not produce a finished interior surface, and the home brewed systems in general are not as easily configured for arches larger than 33 feet in diameter.

For Newhouse Shelter plans contact Yellowstone River Publishing, P.O. Box 206, Emigrant, MT 59027, (800) 585-5077.

Last but not least from the land down under, I know some people in Australia who made their own steel frame kit and successfully built a concrete dome very similar to the E.S.I. system. This may be an option if you have familiarity with and access to the heavy steel bending industry.

Aboveground Shelters

Aboveground fallout shelters are an option in areas where rock or high water tables make it impossible to have an underground shelter. This option involves the construction of some sort of structural supporting envelope above that is then mounded or covered over with dirt that acts as shielding. Some of the structural envelopes that can be used for this option include pre-shaped corrugated metal quonset sections, made especially for burial, conventional steel reinforced concrete, or thin-shell concrete domes and barrel vaults. All of these can support the earth that is piled on top. The thin-shell concrete domes and barrel vaults would have the most resistance to overpressure.

Typical Basement Shelter

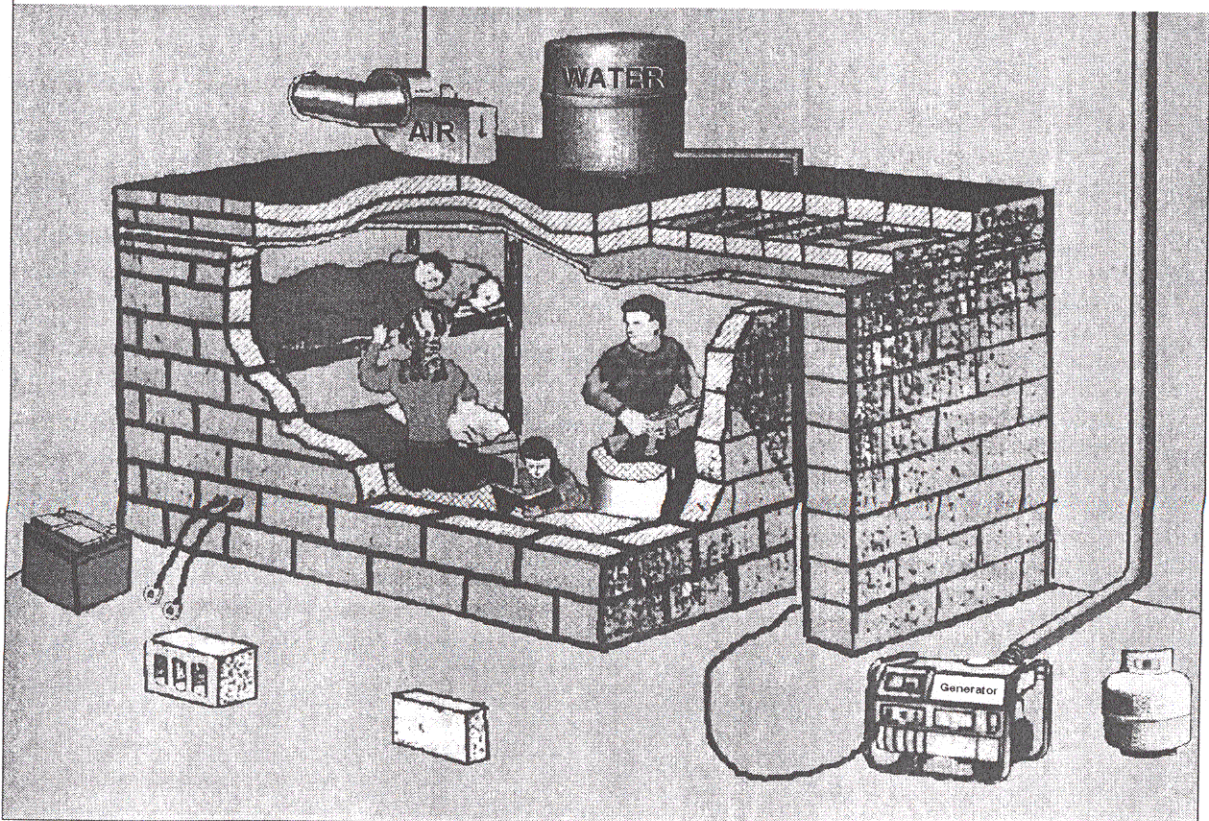

An above ground shelter should have four feet to ten feet of dirt mounded over the top and sides of the shelter. Such an above ground shelter will give fallout protection similar to that of an underground shelter, but it will not provide the same protection against blast and overpressure that an underground shelter gives.

Basement Shelter

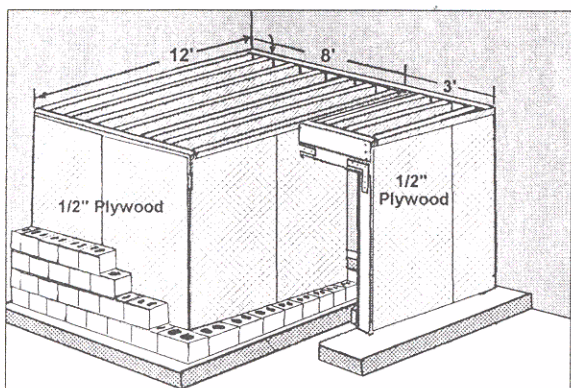
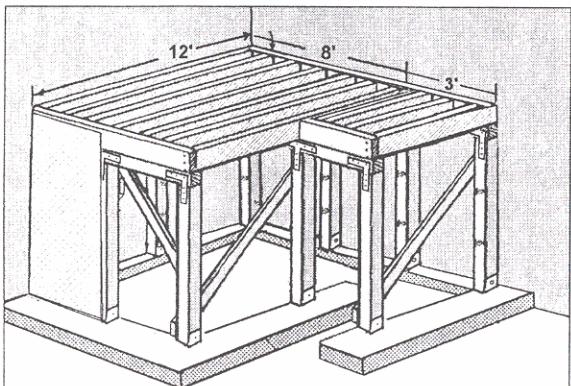
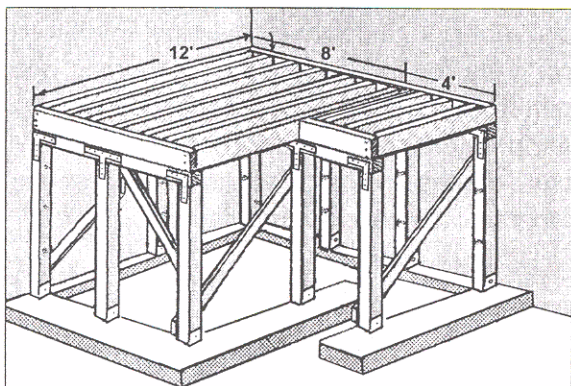

Probably most civilian shelters are in basements. A well-built basement fallout shelter will provide a protection factor of about 100 against fallout radiation. (See chapter on Radiation Shielding.)

Advantages

A basement fallout shelter is probably the most cost-effective type of shelter. These shelters can be more easily concealed. Basement-type shelters make use of an existing structure and in some cases, the sewer, water and gas. If you already have a basement and are not in close proximity to a target, this may be your best option. It is much easier to make effective dual-use out of a basement shelter such as doubling as a family room, recreation room or storage. Your basement shelter is so close that it is much easier to get yourself and all necessary supplies in there on short notice. A basement fallout shelter can provide protection from the initial thermal effects of a detonation. In the event of a nuclear attack, basement fallout shelters could provide adequate protection for the majority of the American people.

Disadvantages

Basement shelters do not have blast protection. In the event of overpressure, the house may be reduced to rubble, covering up or destroying the shelter. In the event that the shelter didn't have a dedicated subterranean exit leading away from the house, the occupants would be trapped. If the blast-generated rubble ignites, high temperatures will be produced right on top of the shelter. Heavier than air gases like carbon monoxide would penetrate non-airtight shelters, killing the occupants. Carbon monoxide poisoning killed most of the people who died in basement shelters during World War II.

Top View

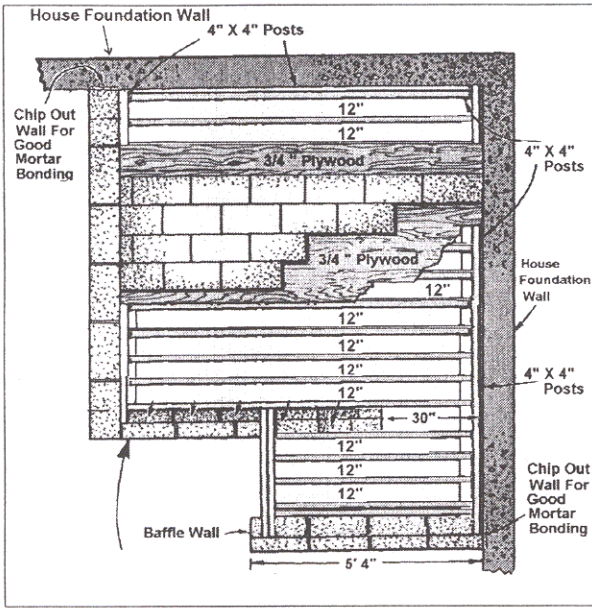

Side View

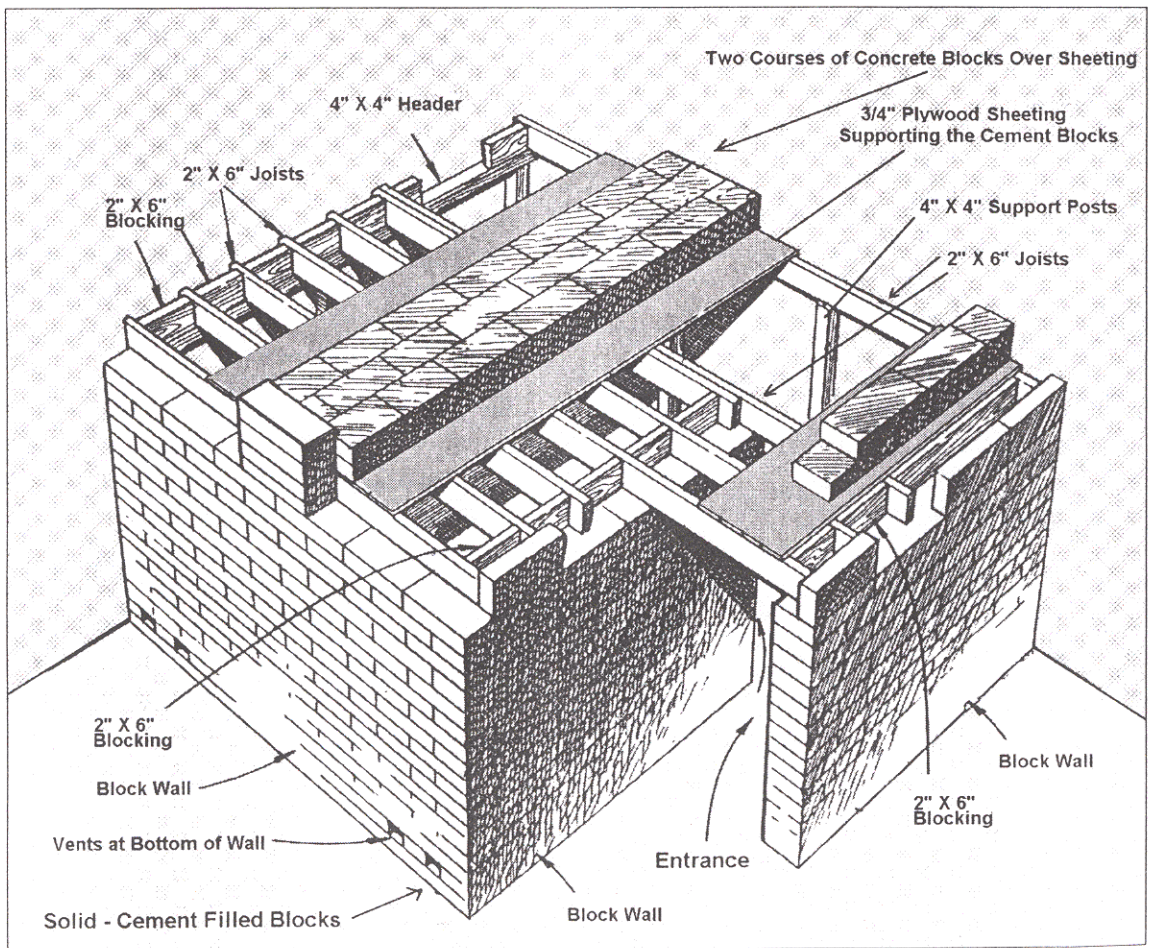
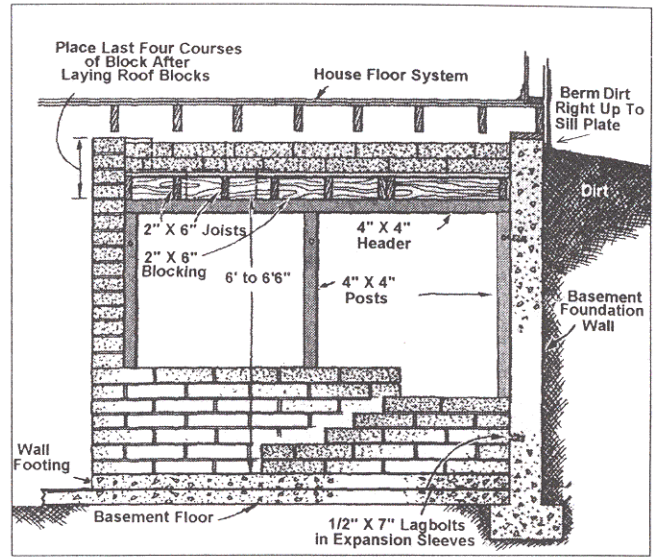

Home basement shelters are generally not applicable for community shelters because they are usually small spaces. Basement shelters don't offer the same protection as buried shelters when it comes to earthquakes and high winds.

Building a Basement Shelter

The basement fallout shelter is a good option for the average do-it-yourselfer on a moderate budget. Solid concrete blocks, sized 4" x 8" x 16", are used for overhead mass shielding and hollow 8"x 8" x 16" blocks are used for the side wall shielding. These blocks can be cut to size where needed.

Making a footing that is a base for the first row of concrete blocks will be the first step in the project. The purpose of a footing is to distribute the load bearing weight that the vertical structural members bring to bear on the concrete slab or ground, in the event that the basement has a dirt floor. The vertical support members carry and transfer the considerable weight of the overhead concrete shielding to the floor and create a point load. This point load could cause the concrete slab to crack or the posts to sink into the ground, in the event of a dirt floor. The footing distributes this point load over a larger surface area. There are several options for the footing. The most permanent option is to create a steel reinforced concrete footing. Another option is to use two 2" x 10" planks laid flat on the floor and nailed tightly together. The plank that is laying flat against the dirt or concrete slab should be treated to prevent rotting.

If you have a concrete slab in the basement it would be a good idea to cut a groove in the slab on either side of the footing. This groove should be cut 1/2" deep on either side

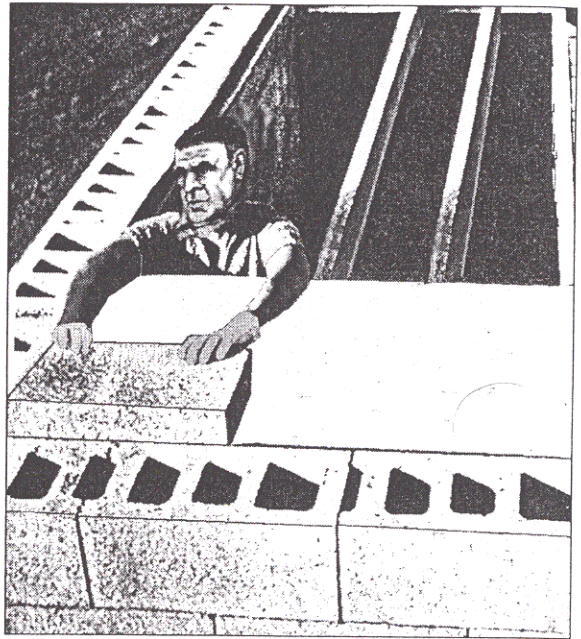

of the footing and run the full length of the footer. This can be done with a circular saw and a diamond masonry blade. Don't be concerned about cutting a groove where the footer runs right up next to a foundation wall. The added weight of the overhead shielding bearing down on a conventional 3" slab could cause cracks to develop in the concrete slab even with a footing. The groove will generally cause any resulting crack to be restricted to the groove. Some builders feel that a footing may not be necessary on a good concrete slab. But if you are concerned about cracks, for best results follow the procedure outlined above.

The concrete footer should be at least 14" wide and 7-1/2" high with three pieces of #4 - 1/2" steel reinforcement bar (rebar). Typically, the forms for the footer are made of 2" x 8" lumber with 1" x 2" boards nailed across the top to keep the 2" x 8" form boards from spreading. You will probably have to nail down onto the concrete slab some 2" x 4" blocks at intervals on the outside edges of the 2" x 8" form boards to keep them from

spreading out on the bottom when the concrete is poured in. These 2" x 4" blocks can be nailed down with a Ramset type powder actuated concrete nail gun. The other option is to drill holes in the concrete, use lead sleeves and bolt the 2" x 4" blocks down.

The next step is to construct the wooden structural framework that will support the roof and create the formwork for the block walls (see the drawings). The main structural members will be 4" x 4"s. These will be used as the vertical posts and ceiling rafter supports. The rafters will be 2" x 6"s. The reason that 2" x 6"s are being used is we usually have limited floor to ceiling space when we are trying to retrofit a fallout shelter in an existing basement. If we only have 8' to start with, we will need 3/4" for maneuvering space, 16" for shielding, 3/4" for sheeting and 5-1/2" for rafters. This comes to a total of 1' 11" leaving only 6' 1" for headspace. If it happens that you only have a 7' floor to ceiling space to start with then this will result in leaving only 5' 1" for headspace. The only way to get around this height limitation is to cut out the basement floor in the area of the shelter room, dig out and pour a new concrete floor at a lower level.

The ceiling will have a great amount of weight, so more than a normal amount of supporting must be done. Steel beams are best, placed close together as many as you can afford. Next best are wooden beams at least 2" x 6". Two 2" x 6" beams nailed together and set on the row of blocks will make a support 4 inches wide and six inches high. Spaced four inches apart, and braced together with lumber these beams will make a strong support.

Make sure that all joints are braced with strong-tie type metal braces (see drawing). Also whenever possible tie the vertical 4" x 4"

supports into the existing basement wall with masonry bolts. This is done by drilling a hole through the 4" x 4", marking where the hole comes out onto the basement wall and then drilling the appropriate sized hole into the basement wall with a masonry bit and a hammer drill. Once this is done an expansion bolt (sometimes referred to as a "Red Head"), should be inserted into the hole. Then put a nut on the end of the expansion bolt and hammer it into the wall. This expands the end and anchors the bolt into the concrete wall. Then unscrew the nut, push the extending bolt through the hole in the 4" x 4", put on a washer, put the nut back on and tighten down.

Once the load bearing framework is up, sheet the exterior walls with 1/2" plywood. Glue (with construction adhesive available in caulk gun form) and nail the plywood (at least every 4" with #8 nails) to all wood that it comes in contact with. This will strengthen the framework and give it more earthquake resistance. It will also give you a form to lay your shielding block wall against. The next step is to sheet the top of the ceiling joists with 3/4" plywood. It may not be possible to nail this plywood down onto the 2" x 6" joists since clearance will be restricted. It would be better if these were nailed to the 2" x 6" joists, but if you can't reach the centers you can nail them down along the edges. Use either #8 nails or 1" roofing nails nailed every 4". The weight of the concrete blocks will hold the plywood in place. Also, in some cases you may have to cut these 4' x 8' sheets of 3/4" plywood in half into a 2' x 8' size. The reason for this is these 2' x 8' sections are put up one at a time. They are then stacked with the four layers of 4" x 8" x 16" concrete block that are laid flat. If the plywood is any wider than 2 feet you might not be able to reach in and stack the block in place due to the limited space between the

surface of the 3/4" plywood and the floor joists above.

On top of the plywood, lay four rows of solid concrete blocks (4" x 8" x 16"), to make a radiation shield 16 inches thick. These blocks are merely laid tightly into place. There is no need to mortar them together.

Mortar is used to fasten each row of 8" x 8" x 16" hollow cavity concrete blocks onto the footer and the progressing wall and it is also used to fill the hollow parts of the hollow cavity block as the rows of the wall block progress upward. It is important from both a radiation shielding and a structural integrity standpoint that all of the vertical cavities in the block be filled with mortar. When the hollow cavity block wall rows progress to a height that is so close to the ceiling joists of the floor above that it becomes difficult to pour or trowel mortar into the block's vertical cavities, switch over from 8" x 8" x 16" hollow cavity concrete blocks to 4" x 8" x 16" solid concrete blocks. Each layer of these solid concrete blocks needs only to be mortared onto the row of blocks below.

Pre-mixed dry mortar can be purchased in sacks from your local masonry supplier or lumberyard. In the event you decide to mix your own mortar the following is a standard mix formula:

- 1 part masonry cement
- 1 part Portland cement
- 4 to 6 parts fine mortar sand

To mix your mortar, use a mixing machine that can be rented at a rental yard or use a wheelbarrow. Work all the dry ingredients together thoroughly in the proportions above. Then slowly add a little water, and mix some more. If too heavy, repeat. It is better to use

too little water than even a little bit too much. When properly mixed, the mortar should be a workable, plastic like mixture. If the mortar dries faster than you are using it, add a little more water as needed and remix. A good test for your mortar is to put a shovel-full aside from the mix and if it stands alone without spreading, and no water runs off, your mortar should be just right. You can mix the mortar in a good wheelbarrow. A hoe will be the easiest tool to use in making your mix.

Another essential tool for this job is a long mason's level. Every block you lay must be checked to make sure it is level. Every row of blocks must also be tested to make sure they are level. A 2 x 4 can be used to tap several blocks down evenly and neatly. Once your footer, or base, for all your walls is in place, and level, you are then ready to start your wall up in rows. Start laying your first row at a corner. Stagger the blocks so they overlap the joints on the layer below. This will put the mortar seams above a solid part of the block below, not above another seam. Alternate the position of the blocks like this in every other row. If your row does not come out the exact length desired, don't worry. Merely trim part of the last block in a row with a mason's hammer.

As the row of blocks goes up, use your level along the vertical rise of the wall to make sure the rows are straight. Laying the blocks up against the vertical 1/2" plywood wall sheeting will insure a consistent and plumb vertical rise. Also every so often screw a masonry tie through the plywood and into the 4" x 4" vertical members. These are mortared into the joints in between the layers of block and tie the block wall into the wooden framework. Excessive mortar should be scraped off blocks with a trowel before it dries.

One other factor to consider is the floor of the basement fallout shelter. Concrete floors can be very cold and uncomfortable to live on. It would be a good idea to lay down on top of the concrete floor rows of 1" x 4" stringers every 12 to 16 inches and sheet with plywood. If headspace will accommodate use 2" x 4"s instead of 1" x 4"s. This elevated floor sheeting will get you up off the concrete floor that tends to conduct heat out of the body.

Air Flow into a Basement Shelter

In some cases basement shelters facilitate a simplified air supply system. If the doors and windows in the basement are blocked by sandbags, air filtering for this type of shelter will not be as necessary. Adequate air will passively filter into the basement from the upper part of the house. Leave the door from the basement to the upstairs open, but make sure all the exterior windows and doors upstairs are closed. Generally speaking, the heavier radioactive fallout will particulate out of the air before it infiltrates the inside of the house. By the time the air gets down to the basement, the vast majority of the radioactive fallout would have particulated out of the air. To provide a good air supply, leave a row of small holes along the second row of wall blocks from the floor level. Also, the offset entrance door can remain open to allow passage of air.

When planning your basement shelter, try to make it a dual-purpose room. If headroom is sufficient, you can have a TV room, playroom, den, or darkroom just by adding inside paneling to the walls. The size of a basement shelter is not too important. It will depend upon how much of your basement you are willing to turn over for this purpose, and upon how many people must be sheltered. A 10' x 10' shelter could accommodate snugly up to six people.

Enhancing Basement Shelter Shielding

On the upper floor of the house, directly over the top of the basement fallout shelter stack anything available that will increase the protective mass over your head. This could include books, mattresses, furniture, kitchen appliances, tables, extra buckets or sacks of food, waterbeds, etc. These items will provide an added measure of protection against radiation. The basement by itself, depending on how it is configured, can provide a 5X to 20X protection factor. Daylight basements would provide the poorest shielding. If there are basement windows, doors or window wells shovel as much dirt as possible over these openings. If dirt is not available, stack whatever is available over, in front of, or around these openings to provide more radiation shielding. If the dirt on the outside does not fully cover the foundation wall do whatever you can to increase the shielding.

Expedient Shelters

Nuclear War Survival Skills, by Cresson Kearny is the authoritative book on this subject. This book covers all aspects of improvising a fallout and light blast shelter. If you are intending to utilize an expedient fallout shelter, his book is a necessity. It's a how-to book and it contains all the facts you need to know to protect yourself from the effects of a

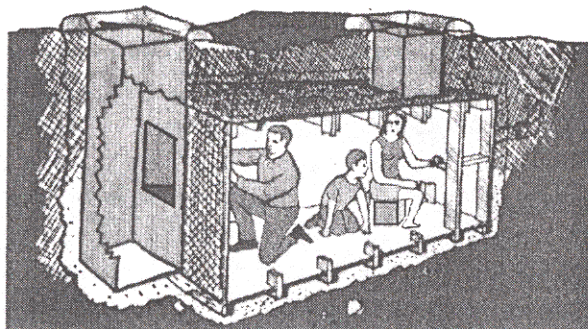

nuclear weapon. To obtain this book contact the Oregon Institute of Science and Medicine, P.O. Box 1279, Cave Junction, Oregon 97523.

Advantages

The advantage of expedient shelters is they are dirt-cheap! They can work for fallout protection if built correctly and no particular care is needed in backfilling. In all fairness, they are certainly better than nothing.

Disadvantages

The disadvantages are many. Expedient shelters will work only if the occupants get enough advance warning to have time to construct them. If someone constructs an expedient shelter in advance of a crisis, this problem would be solved. An additional concern is that most expediently built shelters, due to the nature of their construction, tend to become victims of moisture and rodent damage if they remain unoccupied for any period of time. The available space is extremely confining. The absence of power, light, and sanitation will inevitably make an extended stay in an expedient shelter an unbearable experience.

Government Designated Public Shelters

What about public shelters? You know those designated public civil defense shelters, usually located in basements of schools, banks, etc.

Advantages

No cost to the using party.

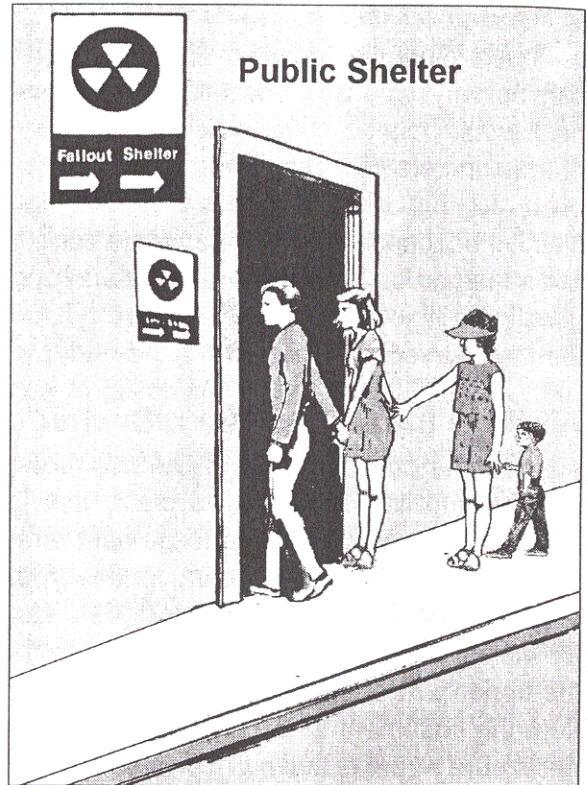

Disadvantages

No deposit, no return. Unfortunately, these so-called shelters will tend to be a place where the average American family will find lots of death and misery for company. Very few public shelters have any emergency stores of food, water, medical supplies or back-up power. None have air filtration capabilities and most will not have working sanitation facilities. When the state civil defense agencies started surveying buildings for use as potential public shelters, they found that there weren't enough structures to accommodate all the people who needed to be housed. The government's solution was to lower the minimum protection factor so more buildings would qualify.

The United States Civil Defense program, for all intents and purposes, exists only on

paper. The bulk of the program involves the mass relocation of people in critical target areas to rural areas. The problem with this plan is threefold. First, a one-week advance warning is needed to implement the relocation. Second, all these people would be moved to areas without adequate shelter, food, sanitation facilities or sources of drinking water. Finally, most of these relocation areas will be contaminated by windborne radioactive fallout.

Shelters for the Elite

Be assured that the U.S. government has been and still is spending billions on secret shelters for important federal, state and corporate officials. Mount Weather is a virtual underground city located near Bluemount, Virginia, 46 miles from Washington D.C. and is officially designated the Western Virginia Office of Controlled Conflict Operations. The Mount Weather staff includes a working duplicate of the Executive Branch of the Federal government and is the central command center for F.E.M.A. It is interesting to note that a

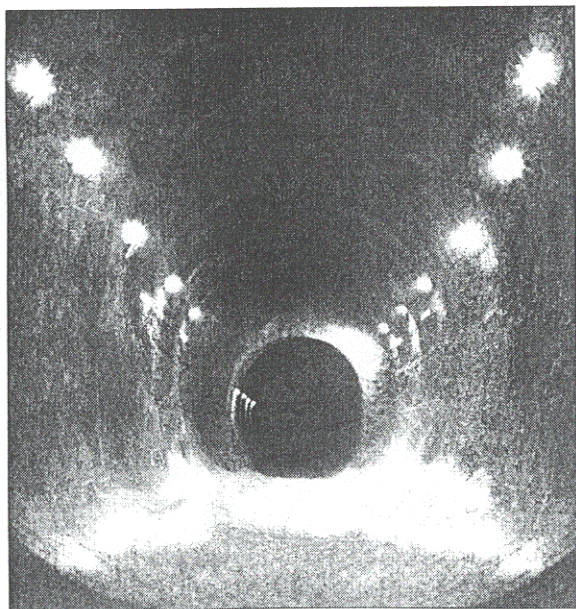

privately owned profit corporation, the Federal Reserve, also has an office in Mount Weather. In the event of war, the declaration of martial law or other national emergencies (potentially including serious financial or political crises), the President, the cabinet and the rest of the Executive Branch would be relocated to Mount Weather. Believe it or not, Congress has little knowledge of this facility and absolutely no budgetary oversight.

In all fairness we shouldn't be too hard on our elite bureaucrats for trying to save their own necks. After all, the Soviets built blast hardened facilities for the KGB, their military command and top party officials; (they obviously are not expecting a nuclear war). Most recently this includes the huge Yamantau complex in the Southern Ural Mountains area of Beloretsk. This complex is purported to be as big as the area inside the Washington beltway. It is not a relic left over from the cold war, but was constructed under Yeltsin's direction. Not bad for a bankrupt country that needs aid from the U.S. to pay for it's own compliance with disarmament treaties. The one thing we can say for the Russian elite is they seem to value their civilian cattle more than their western counterparts. The Russian leadership has built shelters for 70 percent of their civilian population.

My suggestion to every American is to not base your preparedness actions on the government's assurances that all is well, but take a cue from the course of action that the government has quietly taken.

If you want to know more about the billions of tax dollars that has been spent on government underground shelters obtain a copy of the book: *Underground Bases and Tunnels: What is the Government Trying to*

CROSS SECTION OF ACTUAL SHELTER

3 LEVEL CONCRETE BARREL VAULT

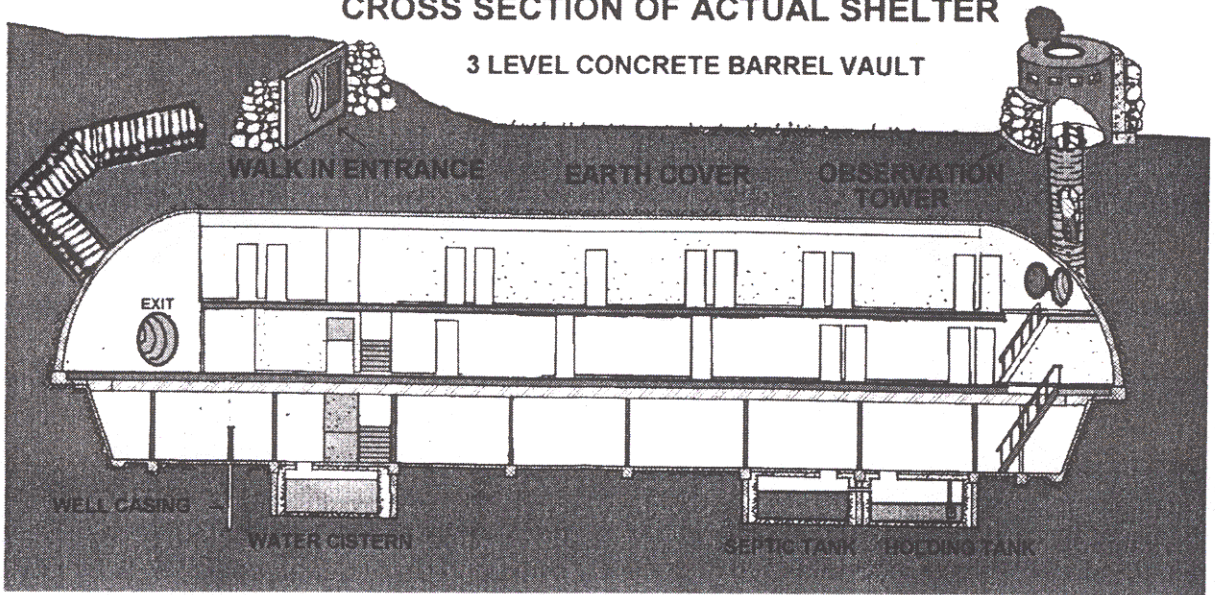

CONCEPTUAL BARREL VAULT SHELTER

2ND LEVEL

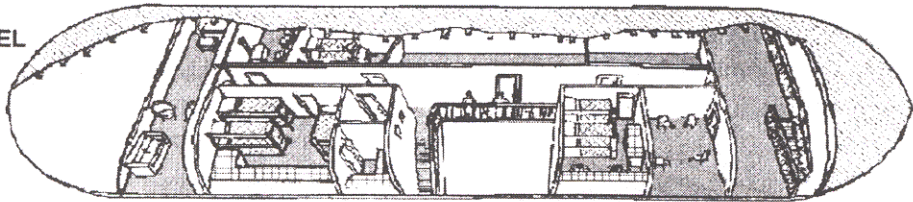

1ST LEVEL



KITCHEN

← INCOMING AIR STACK

WELL CASING →

← BLAST DOOR

CULVERT WALK-IN ENTRY WAY

Hide? by Richard Sauder, Ph.D. (Available from Adventure Press, PG Box 74, Kempton, Illinois 60946, (815) 253-6390, \$15.95, plus \$2 s/h).

Small Versus Large Shelters

Shelter size and capacity should be carefully considered.

Smaller shelters are easier to run in terms of the management and the decision-making process, because fewer people are involved. It is easier to build a smaller shelter secretly while it is virtually impossible to build a larger shelter without people knowing about it. The down side of smaller shelters is that they are usually minimally equipped, are more expensive per person and are potentially harder to protect. Doing one's own thing is a limited option and the overall potential for survival is greatly reduced. Confinement in a small shelter over a long period of time with limited interaction options can produce adverse effects.

Larger shelters provide a greater resource base in terms of personal skills and

able bodied people. There are definite strengths in union and in numbers. Building larger shelters with more occupants makes more effective use of financial resources and allows for better systems and facilities. Larger shelters, generally speaking, provide more potential for privacy and are potentially easier to protect. On the down side, larger shelters may take longer to build and the systems are more complex.

Sub-Earth Home With Dual Use Shelter

The final shelter option to be covered in this chapter is a sub-earth home which has a section of the living quarters shielded. On one of the following pages is a floor plan of an actual sub-earth home. In this house the master bedroom, master bath, pantry and a loft over the bedroom, are situated into the back of the house. This area is separated from the rest of the house by a shielding wall and the roof and sidewalls are shielded with earth.

In the event of a disaster, the owners would quickly move into the shelter portion of the house and have a living space, bathroom

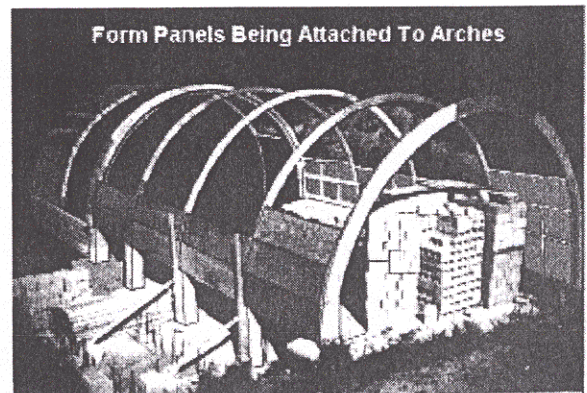
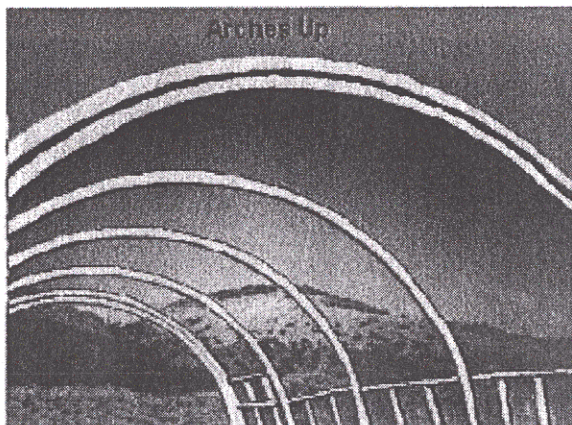

and also the loft space for friends and relatives. The kitchen operations would move into the pantry, which has its own sink. The house also has a low voltage system with battery storage to provide power.

This particular house is built using the Newhouse shelter system. You can view the progressive steps involved in building a Newhouse type steel reinforced concrete barrel vault in the pictures shown.

Steel Reinforced Bar In Place

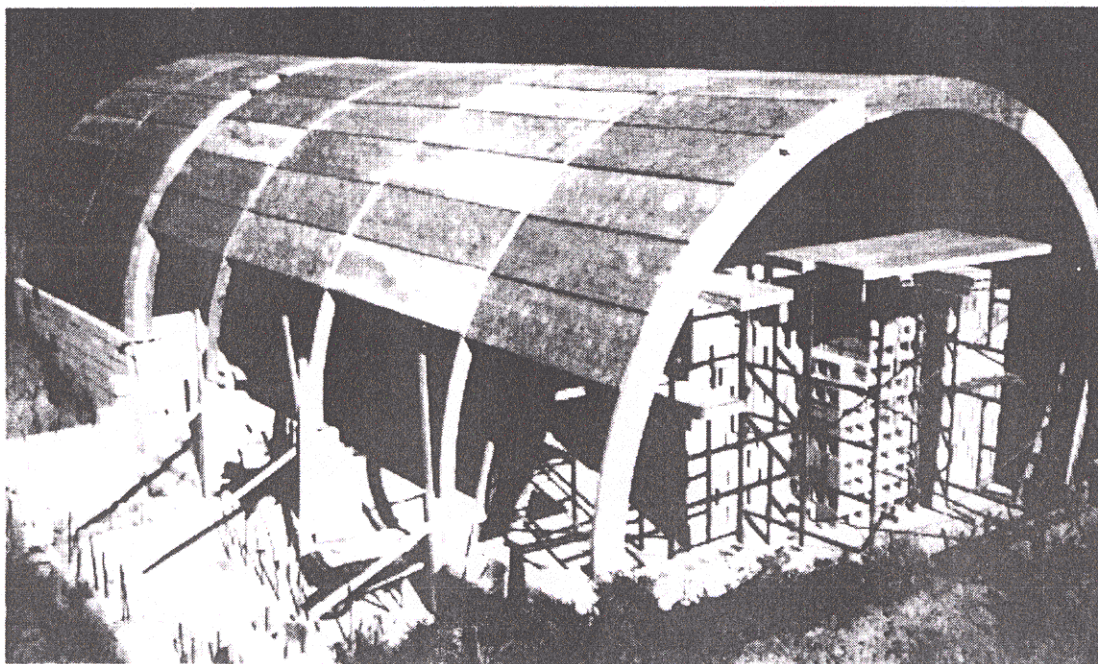
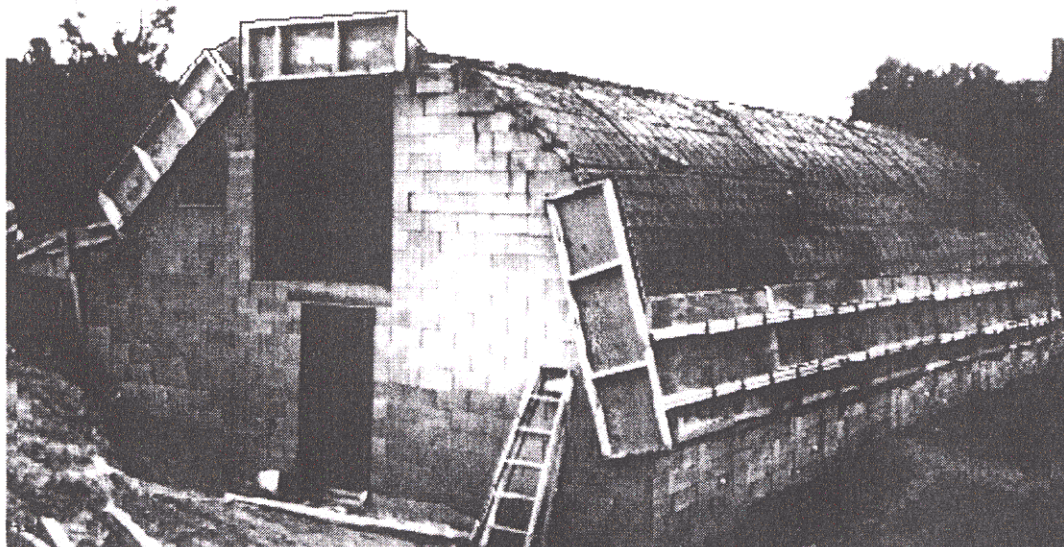

Concrete On The ROOF

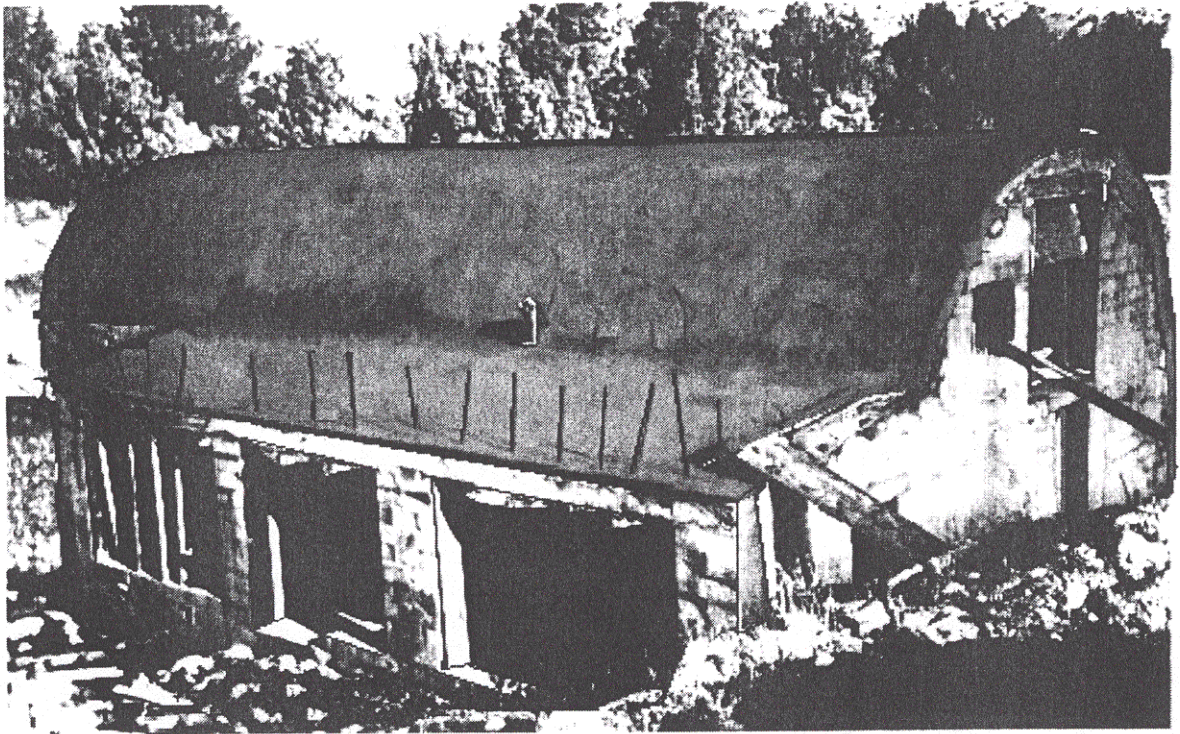

The Finished House

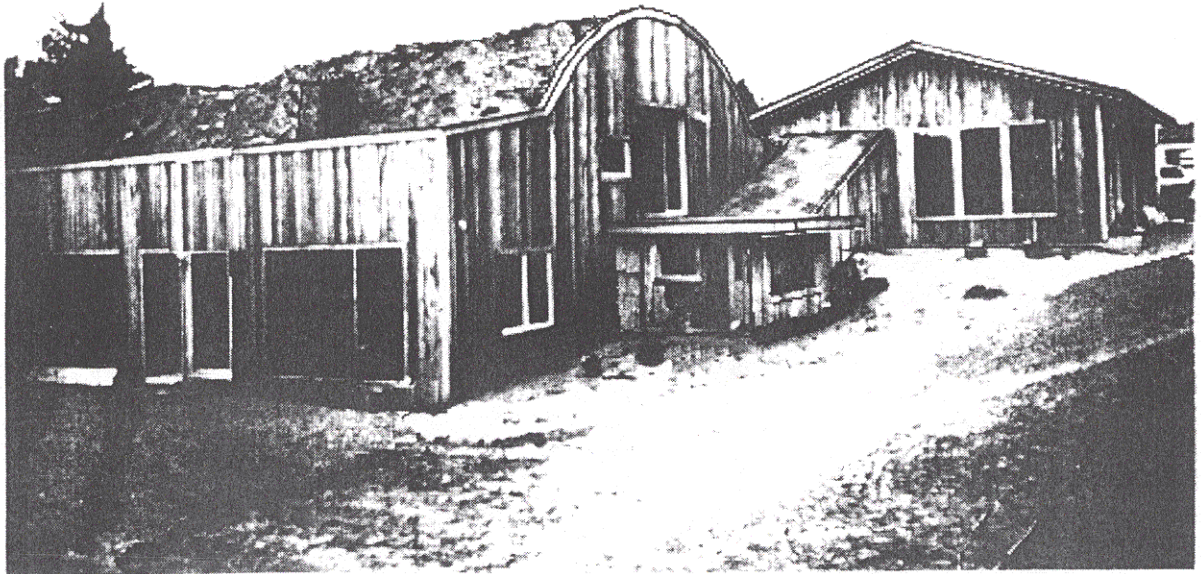

Floor Plan for Sub-Earth Home with Dual Use Shelter Area

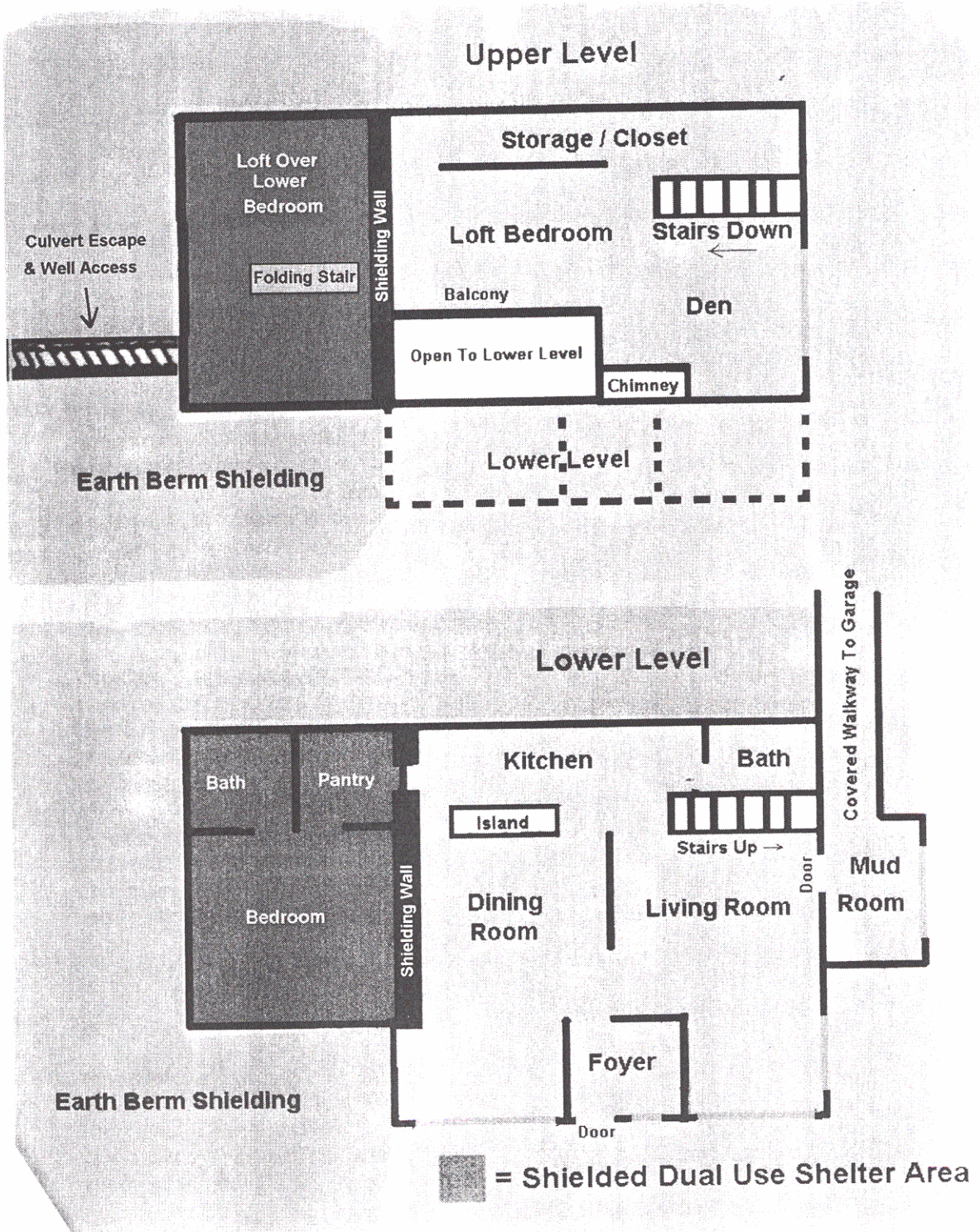

Mines, Tunnels and Caverns

Mines

If you happen to be so fortunate to own a mining claim with a hard rock mine, it is very possible that you can modify it to become an effective shelter. The three big considerations are air supply, safety and moisture control.

Most heavily worked mines have air supply shafts. If the mine does not, it is possible, if access facilitates, to get a well-driller to bore a shaft down to the tunnel from on top. Air supply ducts can also be brought back into the tunnel from the entrance, but it is better if you can draw your supply air from the entrance and use natural convective airflow and exhaust air vertically.

The advantage to using a mine or cavern is that you can drastically reduce building and excavation costs and secure unheard of shielding. If the mine tunnel is old and has shoring braces in it, you should have a professional from the mining industry inspect the mine to insure safety.

Old, unused mines can contain accumulations of methane gas that is colorless, odorless and deadly. When surveying the mine, it is advisable to bring along a methane gas detector. Another potential disadvantage of a mine is that any actual excavation of material can bring the scrutiny of the local state mine safety agency and some states may actually require that permits be obtained.

Tunnels

Railroad and highway tunnels offer the possibility of large-scale emergency shelters. The Swiss have a long highway tunnel which they have outfitted with a blast door, ventila-

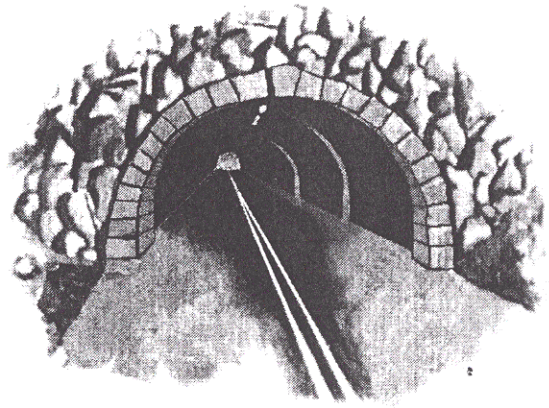

tion, emergency power generation, sanitation and stored beds and supplies to accommodate 7,000 people. In most cases utilizing a highway or rail tunnel will be limited to a government-organized project. The local rail company and the state highway department might not be too excited about you and your friends commandeering a tunnel, especially for a drill, but it is conceivable that a group of citizens could make use of a tunnel in an emergency if they did a little preplanning.

If you were to drive in a water truck, a trailer full of porta-potties, and a truck full of food from your local grocer or other sources, you would have all the basics for an expedient tunnel shelter. The only other essential ingredients would be a backhoe, sand bags (or feed sacks), and shovels. The backhoe would break up the compacted earth, and there shouldn't be any shortage of volunteers to man the shovels, and fill and stack sand bags. If an 8 to 10 foot high by at least 4-foot deep sandbag barrier was constructed on either end of the tunnel, you could obtain reasonable shielding against radioactive fallout. People can shovel a lot of dirt in a real short time when their lives depend on it.

The open space between the top of the sandbag barrier and the roof of the tunnel on either end would facilitate ventilation and

minimal lighting during the day. Have everyone bring their sleeping bags and camping gear, and have a two to three week campout.

Caverns

There are many extensive complexes of underground caverns in various parts of the United States. Most of these are government owned and access is controlled. This fact would tend to prohibit modification and stock-

piling of equipment. But if individuals were to pre-plan and be organized, they could probably make use of such caverns during a crisis. Of course each cavern would have to be evaluated for its natural ventilation capabilities and the availability of water.

To find out more about caverns in your area, contact the local cave exploring group. Get certified training from these people and then go tour the local caves.

**A last minute shelter builder getting ready for a two week stay under the basement workbench.
(More advanced thought and planning will produce happier campers.)**

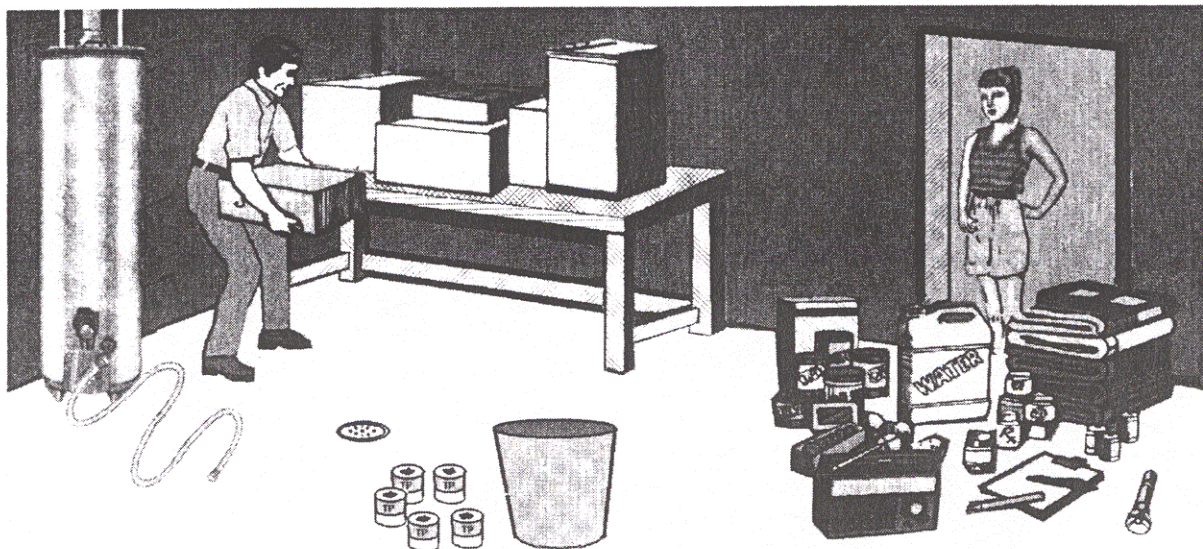

The Granddaddy Of All Underground Storage Areas

- **This is an example of a shelter made from an underground storage container made from culvert. This concept is extremely bold in every way. When it comes to underground storage, this may very well be the granddaddy of them all. I am convinced this is one of the finest underground storage ideas you will find anywhere**
-

A bold new concept: Whoever thought of this ranks as a genius of the simple. Basically, this underground storage area is made in a culvert that was designed for bridging creeks. Culverts are thin steel pipes that are very strong, light for their size, inexpensive when compared to other types of construction, galvanized and therefore rustproof. They come in a wide variety of sizes, from as small as one foot in diameter to 20 feet in diameter and bigger. Because of the huge size possibilities, culverts can fit into just about anyone's underground storage needs. Our showcase structure was built into an eight foot culvert, however, many people building this type of shelter are now using ten foot culverts.



Easily and quickly constructed: This photo shows the culvert as it was near the end of construction. It is made from an eight foot culvert 50 feet long. Steel plates were welded onto each end to enclose the culvert. A one foot in diameter vent tube, again made from culvert, was placed in the top of the culvert on each end (not shown). The culvert coming off the top side of the main culvert at one end in the photo is a four foot culvert. Before the shelter was set into place, the culvert was rotated down so the small attached culvert was on the side of the main culvert. Then a length of four foot diameter culvert was welded on which became the entrance way. Before it was set into place, the entire outside surface, especially the welded portions, were sprayed with tar to prevent rusting. The floor inside the culvert was constructed from 2X4s and 1 inch plywood. This was placed in the culvert at the five foot wide point, being about 10 inches above the bottom of the culvert. With the floor at this point, there is



slightly over seven feet of head room when standing. Next came the door on the front of the entrance way. Our featured shelter has a small six by six foot porch built around the culvert entrance which has a wooden door to the outside. There is also a second inner door constructed from steel, enclosing the four foot diameter entrance culvert. All that remains to be done is to put in the walls and shelves.

Quickly set into place: The hole for this shelter was dug in one day. The shelter was brought in and set into place with the vents and entrance pipe welded into place the next day, then it was buried the third day.

Inexpensive for the size: The owner of our featured shelter spent \$5,000 in 1990 on all aspects of constructing and burying this shelter. (It would cost about \$10K now (1998) with the proper blast doors.) He did say that a lot of the wood for the floor and shelves was scrounged.



Plenty of room: Our featured shelter's 5 foot wide floor has 250 square feet of surface. Total storage area volume comes out to about 2,400 cubic feet.



Easily adaptable as an underground shelter: Our featured shelter has a bed, dresser, small living area, library, and a large storage area.



This photo shows the end of the shelter next to the entrance. Note the 4 foot diameter culvert coming off the left just before the bed. The entrance pipe wasn't put on the very end of the 50 foot long culvert for a very good reason - so the bed would fit. Note also the vent pipe in the ceiling. The owner said he would cut it off close to flush with the ceiling if he had to do it over again.

We show you the first photo again to explain the two rock towers on top of the shelter. These enclose the vents, and was done this way so kids couldn't shoot holes through them.

Your underground shelter can easily be hidden from view - no one even needs to know it's there: With a tiny bit of forethought and planning, the vents could be easily hidden by terrain, in shrubbery, a rock garden, or in carefully placed outbuildings. The same could be done with the entrance way.

