

[Full Transcript below]

Link Notes: Below are archived links for all cosmic disclosure episode transcripts up to season 10, episode 5. At least, I believe I have collected all of them. When possible, 2 links are provided for each episode in case one gets taken down. Only 1 link was available starting in the middle of season 8. I recommend sticking with the “alternative link” links below because most often the pictures are available in these links, and not in the first link. The exception is season 6, episode 14. Though the pictures were not properly saved for either link for a few. This also serves as the table of contents for the episodes.

If you appreciate this content, please consider supporting David Wilcock and Corey Goode. You can make donations to them here:

[David](#); [Corey](#); [Emery](#). (Note, you can access the donation page through their store page below as well)

You can also make purchases from their store:

[David's Store](#); [Corey's Store](#); [Emery's page](#).

Also, consider purchasing their recent movie [“above majestic” for yourself or a friend](#).

Season 1, Episode 1 [Cosmic Disclosure: The Message for Humankind \(alternative link\)](#)

Season 1, Episode 2 [Cosmic Disclosure: First Encounter \(alternative link\)](#)

Season 1, Episode 3 [Cosmic Disclosure: Lunar Operation Command \(alternative link\)](#)

Season 1, Episode 4 [Cosmic Disclosure: Life On The Research Vessel \(alternative link\)](#)

Season 1, Episode 5 [Cosmic Disclosure: We Are One \(alternative link\)](#)

Season 1, Episode 6 [Cosmic Disclosure: Sleeping Giants \(alternative link\)](#)

Season 1, Episode 7 [Cosmic Disclosure: Mars Colony Inspection \(alternative link\)](#)

Season 1, Episode 8 [Cosmic Disclosure: Global Galactic League of Nations \(alternative link\)](#)

Season 1, Episode 9 [Cosmic Disclosure: Electric Sun \(alternative link\)](#)

Season 1, Episode 10 [Cosmic Disclosure: Awakening the Pineal Gland \(alternative link\)](#)

Season 1, Episode 11 [Cosmic Disclosure: Potential Of Human Consciousness \(alternative link\)](#)

Season 1, Episode 12 [Cosmic Disclosure: Portals: Cosmic Web \(alternative link\)](#)

Season 1, Episode 13 [Cosmic Disclosure: Portals Navigating Time \(alternative link\)](#)

Season 2, Episode 14 [Cosmic Disclosure: Portals Parallel Earth \(alternative link\)](#)

Season 2, Episode 1 [Cosmic Disclosure: Contact Is Made \(alternative link\)](#)

Season 2, Episode 2 [Cosmic Disclosure: Agarthans: Advancing the Frontier \(alternative link\)](#)

Season 2, Episode 3 [Cosmic Disclosure: The Gonzales Enigma \(alternative link\)](#)

Season 2, Episode 4 [Cosmic Disclosure: Breakaway Begins \(alternative link\)](#)

Season 2, Episode 5 [Cosmic Disclosure: Raiders of Lost Technology \(alternative link\)](#)

Season 2, Episode 6 [Cosmic Disclosure: We Were Never Alone \(alternative link\)](#)

Season 2, Episode 7 [Cosmic Disclosure: Remnants Of Ancient Mars \(alternative link\)](#)

Season 2, Episode 8 [Cosmic Disclosure: Finding Life On Mars \(alternative link\)](#)

Season 2, Episode 9 [Cosmic Disclosure: Colonizing Mars \(alternative link\)](#)

Season 2, Episode 10 [Cosmic Disclosure: Conquering the Solar System \(alternative link\)](#)

Season 2, Episode 11 [Cosmic Disclosure: Beyond the Limits of the Sun \(alternative link\)](#)

Season 2, Episode 12 [Cosmic Disclosure: SSP Sciences \(alternative link\)](#)

Season 2, Episode 13 [Cosmic Disclosure: Viewer Questions Part 1 \(alternative link\)](#)

Season 2, Episode 14 [Cosmic Disclosure: The Threat from Artificial Intelligence \(alternative link\)](#)

Season 2, Episode 15 [Cosmic Disclosure: Standing Guard against the A.I. \(alternative link\)](#)

Season 2, Episode 16 [Cosmic Disclosure: New Frontiers in the A.I. War \(alternative link\)](#)

Season 2, Episode 17 [Cosmic Disclosure: Viewer Questions Part 2 \(alternative link\)](#)

Season 3, Episode 1 [Cosmic Disclosure: Introduction To Inner Earth \(alternative link\)](#)

Season 3, Episode 2 [Cosmic Disclosure: A Goode Trip to the Inner Earth \(alternative link\)](#)

Season 3, Episode 3 [Cosmic Disclosure: Ubuntu and the Blue Avian Message Part 1 \(alternative link\)](#)

Season 3, Episode 4 [Cosmic Disclosure: Revelations From The Inner Earth \(alternative link\)](#)

Season 3, Episode 5 [Cosmic Disclosure: The Grand Tour of Inner Earth \(alternative link\)](#)

Season 3, Episode 6 [Cosmic Disclosure: Inner Earth – The Library \(alternative link\)](#)

Season 3, Episode 7 [Cosmic Disclosure: Inner Earth - Into the Hall of Records \(alternative link\)](#)

Season 3, Episode 8 [Cosmic Disclosure: Inner Earth - Debriefing with the Alliance \(alternative link\)](#)

Season 3, Episode 9 [Cosmic Disclosure: Ubuntu and the Blue Avians' Message Part 2 \(alternative link\)](#)

Season 4, Episode 1 [Cosmic Disclosure: Super Earth \(alternative link\)](#)

Season 4, Episode 2 [Cosmic Disclosure: Who Built the Moon? \(alternative link\)](#)

Season 4, Episode 3 [Cosmic Disclosure: Age Regression and Time Travel Technology \(alternative link\)](#)

Season 4, Episode 4 [Cosmic Disclosure: Government Troll Data Center \(alternative link\)](#)

Season 4, Episode 5 [Cosmic Disclosure: Voice of God Technology \(alternative link\)](#)

Season 4, Episode 6 [Cosmic Disclosure: The Dark Fleet \(alternative link\)](#)

Season 4, Episode 7 [Cosmic Disclosure: Viewer Questions Part 3 \(alternative link\)](#)

Season 4, Episode 8 [Cosmic Disclosure: Inner Earth Update \(alternative link\)](#)

Season 4, Episode 9 [Cosmic Disclosure: Personality Metamorph Program \(alternative link\)](#)

Season 4, Episode 10 [Cosmic Disclosure: The Earth Alliance \(alternative link\)](#)

Season 4, Episode 11 [Cosmic Disclosure: Viewer Questions Part 4 \(alternative link\)](#)

Season 5, Episode 1 [Cosmic Disclosure: Celestial Timeline \(alternative link\)](#)

Season 5, Episode 2 [Cosmic Disclosure: Remote Viewing and Influencing \(alternative link\)](#)

Season 5, Episode 3 [Cosmic Disclosure: Blue Avians & Spheres in Ancient Art \(alternative link\)](#)

Season 5, Episode 4 [Cosmic Disclosure: Symbiotic Relationships of Ascension \(alternative link\)](#)

Season 5, Episode 5 [Cosmic Disclosure: Spiritual Ascension vs. Technology \(alternative link\)](#)

Season 5, Episode 6 [Cosmic Disclosure: Plasma Beings and Etheric Entities \(alternative link\)](#)

Season 5, Episode 7 [Cosmic Disclosure: Veiled Threats and Open Disclosures \(alternative link\)](#)

Season 5, Episode 8 [Cosmic Disclosure: From Venus to Antarctica \(alternative link\)](#)

Season 5, Episode 9 [Cosmic Disclosure: Anniversary Special \(alternative link\)](#)

Season 5, Episode 10 [Cosmic Disclosure: SSP Testimonials with William Tompkins \(alternative link\)](#)

Season 5, Episode 11 [Cosmic Disclosure: William Tompkins Bio \(alternative link\)](#)

Season 5, Episode 12 [Cosmic Disclosure: SSP Think Tank with William Tompkins \(alternative link\)](#)

Season 5, Episode 13 [Cosmic Disclosure: Empaths and Extraterrestrials with Clifford Stone \(alternative link\)](#)

Season 5, Episode 14 [Cosmic Disclosure: Clifford Stone Bio \(alternative link\)](#)

Season 5, Episode 15 [Cosmic Disclosure: Close Encounters with Clifford Stone \(alternative link\)](#)

Season 5, Episode 16 [Cosmic Disclosure: On the Other Side of the Veil of Secrecy \(alternative link\)](#)

Season 5, Episode 17 [Cosmic Disclosure: Validating the History of the Secret Space Program \(alternative link\)](#)

Season 6, Episode 1 [Cosmic Disclosure: The Earth Alliance Strikes Back \(alternative link\)](#)

Season 6, Episode 2 [Cosmic Disclosure: The Return of Gonzales \(alternative link\)](#)

Season 6, Episode 3 [Cosmic Disclosure: Encounters with Ancient Sentinels \(alternative link\)](#)

Season 6, Episode 4 [Cosmic Disclosure: Validating the 20 & Back Program with William Tompkins \(alternative link\)](#)

Season 6, Episode 5 [Cosmic Disclosure: Arrival of the Spheres with William Tompkins \(alternative link\)](#)

Season 6, Episode 6 [Cosmic Disclosure: Exploitation of E.T. Technology with Clifford Stone \(alternative link\)](#)

Season 6, Episode 7 [Cosmic Disclosure: Your Guide to ETs with Clifford Stone \(alternative link\)](#)

Season 6, Episode 8 [Cosmic Disclosure: Founders of Solar Warden with William Tompkins \(alternative link\)](#)

Season 6, Episode 9 [Cosmic Disclosure: The Law of One and The Secret Space Program \(alternative link\)](#)

Season 6, Episode 10 [Cosmic Disclosure: Guiding Humanity to Ascension \(alternative link\)](#)

Season 6, Episode 11 [Cosmic Disclosure: The Banished, From Inner Earth \(alternative link\)](#)

Season 6, Episode 12 [Cosmic Disclosure: Troubling Encounters \(alternative link\)](#)

Season 6, Episode 13 [Cosmic Disclosure: Law of One and The Secret Space Program: Technological Salvation \(alternative link\)](#)

Season 6, Episode 14 [Cosmic Disclosure: Life After Disclosure \(alternative link\)](#)

Season 6, Episode 15 [Cosmic Disclosure: Interview with the Insider \(alternative link\)](#)

Season 6, Episode 16 [Cosmic Disclosure: Revealing a Bigger Plan \(alternative link\)](#)

Season 6, Episode 17 [Cosmic Disclosure: Viewer Questions Part 5 \(alternative link\)](#)

Season 7, Episode 1 [Cosmic Disclosure: Lifting the Military Industrial Curtain with Heather Sartain \(alternative link\)](#)

Season 7, Episode 2 [Cosmic Disclosure: Revealing Hidden Technology with Heather Sartain \(alternative link\)](#)

Season 7, Episode 3 [Cosmic Disclosure: Law of One and SSPs: Negative Forces \(alternative link\)](#)

Season 7, Episode 4 [Cosmic Disclosure: Law of One and the SSPs: Consequences of Channeling \(alternative link\)](#)

Season 7, Episode 5 [Cosmic Disclosure: The Great Solar Flash \(alternative link\)](#)

Season 7, Episode 6 [Cosmic Disclosure: Transformation Power of The Great Solar Flash \(alternative link\)](#)

Season 7, Episode 7 [Cosmic Disclosure: Deeper Disclosures from William Tompkins \(alternative link\)](#)

Season 7, Episode 8 [Cosmic Disclosure: Antarctica: The Process for Disclosure \(alternative link\)](#)

Season 7, Episode 9 [Cosmic Disclosure: Corroborating the Evidence with Michael Salla \(alternative link\)](#)

Season 7, Episode 10 [Cosmic Disclosure: Disclosure and the Secret Underground War \(alternative link\)](#)

Season 7, Episode 11 [Cosmic Disclosure: Tracing the Roots of the SSP with Michael Salla \(alternative link\)](#)

Season 7, Episode 12 [Cosmic Disclosure: Viewer Questions Part 6 \(alternative link\)](#)

Season 7, Episode 13 [Cosmic Disclosure: Pushing the Limits of Disclosure with John Lear \(alternative link\)](#)

Season 7, Episode 14 [Cosmic Disclosure: Secrets of the Apollo Missions with William Tompkins \(alternative link\)](#)

Season 7, Episode 15 [Cosmic Disclosure: Viewer Questions Part 7 \(alternative link\)](#)

Season 7, Episode 16 [Cosmic Disclosure: Astral Projection and Our Place in the Universe with William Tompkins \(alternative link\)](#)

Season 7, Episode 17 [Cosmic Disclosure: Allying with the MIC SSP \(alternative link\)](#)

Season 7, Episode 18 [Cosmic Disclosure: Revealing the Original Secret Space Vehicles with Mark McCandlish \(alternative link\)](#)

Season 7, Episode 19 [Cosmic Disclosure: Antarctica: The New Area 51 \(alternative link\)](#)

Season 7, Episode 20 [Cosmic Disclosure: Faster Than Light Technology with Mark McCandlish \(alternative link\)](#)

Season 7, Episode 21 [Cosmic Disclosure: Boyd Bushman's Deathbed Testimonial \(alternative link\)](#)

Season 7, Episode 22 [Cosmic Disclosure: Zero Point Energy and Advanced Propulsion Technology \(alternative link\)](#)

Season 7, Episode 23 [Cosmic Disclosure: Analyzing Joseph Skipper's Photo Archive \(alternative link\)](#)

Season 7, Episode 24 [Cosmic Disclosure: Wormholes and Breakaway Civilizations with Mark McCandlish \(alternative link\)](#)

Season 7, Episode 25 [Cosmic Disclosure: Darkness on the Far Side of the Moon with Niara Isley \(alternative link\)](#)

Season 7, Episode 26 [Cosmic Disclosure: Viewer Questions 8: Protocols and Loopholes \(alternative link\)](#)

Season 7, Episode 27 [Cosmic Disclosure: Viewer Questions 8: Protocols and Loopholes \(alternative link\)](#)

Season 7, Episode 28 [Cosmic Disclosure: Viewer Questions 9: Time Travel and The Future \(alternative link\)](#)

Season 7, Episode 29 [Cosmic Disclosure: Testimony on Pyramids and Underground Cities \(alternative link\)](#)

Season 7, Episode 30 [Cosmic Disclosure: UFOs under Antarctica and the Five-Fingered Mystery \(alternative link\)](#)

Season 7, Episode 31 [Cosmic Disclosure: Three-Fingered Technology with Pete Peterson \(alternative link\)](#)

Season 7, Episode 32 [Cosmic Disclosure: The Grand Experiment \(alternative link\)](#)

Season 8, Episode 1 [Cosmic Disclosure: David Adair Bio \(alternative link\)](#)

Season 8, Episode 2 [Cosmic Disclosure: The Original Rocket Man with David Adair \(alternative link\)](#)

Season 8, Episode 3 [Cosmic Disclosure: The Descent Into Area 51 with David Adair \(alternative link\)](#)

Season 8, Episode 4 [Cosmic Disclosure: Timeline Splits and Diversionary Tactics \(alternative link\)](#)

Season 8, Episode 5 [Cosmic Disclosure: Remembering William Tompkins - Disrupting Draco Domination \(alternative link\)](#)

Season 8, Episode 6 [Cosmic Disclosure: Viewer Questions 10: Ascension Concerns and End Times Madness \(alternative link\)](#)

Season 8, Episode 7 [Cosmic Disclosure: The Ascension of Earth \(alternative link\)](#)

Season 8, Episode 8 [Cosmic Disclosure: Viewer Questions 11: Preparing for Ascension](#)

Season 8, Episode 9 [Cosmic Disclosure: Zuni Disclosure with Clifford Mahooty](#)

Season 8, Episode 10 [Cosmic Disclosure: Hopi and Zuni Prophecies with Clifford Mahooty](#)

Season 8, Episode 11 [Cosmic Disclosure: Alchemy and The Law of One](#)

Season 9, Episode 1 [Cosmic Disclosure: Guide to Non-Terrestrial Beings](#)

Season 9, Episode 2 [Cosmic Disclosure: Emery Smith - Whistleblower](#)

Season 9, Episode 3 [Cosmic Disclosure: Inner Earth In Crisis](#)

Season 9, Episode 4 [Cosmic Disclosure: Operation Chaos](#)

Season 9, Episode 5 [Cosmic Disclosure: Undersea Bases](#)

Season 9, Episode 6 [Cosmic Disclosure: Technologies of the Secret Base](#)

Season 9, Episode 7 [Cosmic Disclosure: Clones and Programmable Life Forms](#)

Season 9, Episode 8 [Cosmic Disclosure: Staged Alien Abductions](#)

Season 9, Episode 9 [Cosmic Disclosure: Hybrid Creatures and Secret Bases](#)

Season 9, Episode 10 [Cosmic Disclosure: Secrets at the South Pole](#)

Season 9, Episode 11 [Cosmic Disclosure: Nazca Tunnels and Super-Suit Technology](#)

Season 9, Episode 12 [Cosmic Disclosure: The Dangers of Being an SSP Whistleblower](#)

Season 10, Episode 1 [Cosmic Disclosure: Tragic Consequences Aboard a Mayan Ship](#)

Season 10, Episode 2 [Cosmic Disclosure: End of the Super Federation](#)

Season 10, Episode 3 [Cosmic Disclosure: The Anshar and Red-Headed Giants](#)

Season 10, Episode 4 [Cosmic Disclosure: Alien Tech at the Vatican](#)

Season 10, Episode 5 [Cosmic Disclosure: Bioship](#)

Navigation: Hold control and press f. The search box will appear, type the name of the episode you want to read, and go to it.

Editing Note: As much as possible, the original pictures were included. Most were available. However, for some of the episodes the archive did not save the original pictures. I tried to note where the pictures were not available. In addition, pictures of the Corey and crew in the episode giving the interviews

were only included the first few 2-3 times they appeared. After that, those pictures didn't add much and only increased the file size and length. If you somehow forget what Corey and the crew look like, you can go to their websites because they have pictures of themselves plastered everywhere. Anything weird was included no matter how many times it repeated. Lastly, bolded names were added for readability, though it also made some bold inside the actual speaking. This was not removed because that would be tedious.

Artist credits: Arthur Herring Art. Find him on Facebook

@Facebook.com/vashta.art www.vashta.com

Daniel Gish gishdesigns.wix.com/home

Cosmic Artists: Rene Armenta, Charles Pemberton. Steve Cefalo, Stellan Tonring

Cosmic Disclosure: The Message for Humankind

Season 1, Episode 1

DW : We are interviewing a truly remarkable man, **Corey Goode**, age 45, originally from Texas. And you still live in Texas actually. And what he has done here is to come forward as an insider and share with me more information about what's really going on behind the scenes in the so-called secret government and secret military programs and their development and industrialization of our solar system. It's a truly remarkable story, because I've interviewed dozens of insiders over the years with classification sometimes 35 levels above the President of the United States. I've withheld about 90% of that information from the public. Because A, it could get people killed. B, I didn't want to release things that would then spoil me being able to figure out who the real insiders were. **Corey** came along, and he not only knew the 90%, he had many other puzzle pieces that I had been looking for. I knew there was something that people weren't telling me. And it all came together. So **Corey**, welcome to the show. Thank you for being here.

CG : Thank you.

DW : I understand that what you're about to tell us is so far out that people are going to have a really hard time accepting this, particularly if they don't already have a background in this. So instead of trying to hold them by the hand and take this slowly, let's just dive right in. And if you could really

quickly give us an overview of your involvement with what this whole space program subject has been in your life.

CG : Okay. For me, it started at the age of six years old when I was brought into what is known as the MILAB, some pronounced it MILAB programs. I was identified as an intuitive empath.

DW : What does that mean exactly ?

CG : Intuitive, you have a deep intuition of things that are possibly about to happen.

DW : So like psychic ability ?

CG : Yeah, precognitive abilities. And empathic, being that you have a strong emotional connection with others around you. You can feel what they're feeling and connect with them emotionally. That was a skill-set that was desired. And I was trained, and that was enhanced. And it was enhanced to a point where I was around 12 or 13 years old, me and a few of the people that I was training with, being brought into a program to we were what they called IE support for the Earth delegation in a super federation. And this was a federation of a large amount of ET federations that met to discuss the grand experiment.

DW : What was this experiment? What were these ETs doing?

CG : There was a group of 40 human-looking ETs that were pretty much always present, and up to 60 at other times that were present. There were 22 genetic programs that were going on.

DW : What does that mean ? What's a genetic program ?

CG : Programs of them mixing their genetics and manipulating our genetics.

DW : That was ongoing ?

CG : Yes, it's ongoing right now. And this is what this was all about. And the earth delegates had been trying to become a part of this for a long time. And they were finally able to get a seat. And as the intuitive empaths, when we were sitting there, we didn't know what was going on. Because a lot of what was going on was happening in this ancient ET language that's real monotone that we didn't understand. And some of what was going on was going on telepathically. So we were just sitting there, and we were given this device that was a glass smart pad – that's kind of like an iPad - that had access

to the ET, basically, database. And we were told to keep our minds occupied by looking through all this material, and this also helped us with our intuitive empath abilities in detecting danger or deception.

DW : What kind of stuff were you able to look at on these pads ?

CG : It was, mainly they wanted us looking at the information about these 22 genetic experiments that were going on, but we had access to all types of other information. And depending on, each of us - we all had own interests - we would look at all kinds of information. And there's so much information that I looked at, it's almost like looking back at your college days, all the books that you read and all the information you looked at. How much of it do you retain? You know, like that? There was just so much information.

DW : Did you ever have a question that you asked that you couldn't get the answer to, where it just says, I don't know?

CG : No. I mean, you were pretty much given the information that was available. You would run across certain things that the human delegation, and all that, that our group, were not privy to. But pretty much all of the information was open to us.

DW : What did the screen look like? Was it similar to an iPad or?

CG : No, it was just - it looked almost like a piece of Plexiglas. Unremarkable if you saw it. If they would have dropped it out of the window, and you found it in a field, you'd pick it up, and you would not know it was anything special. You would put it on your hand, and you would have to activate it, with a mental component. And it would pop up in your language. The information, you would access the database through your mind, and it would show what you wanted. It would show text, pictures, video, and the video and pictures were holographic in a way that it came off the screen a little bit. I mean, it didn't totally come out of the screen in holographic ways some people would think. But it had just this 3D depth holographic view to it.

DW : And could you still see your hand at that point underneath the glass?

CG : No.

DW : So it would darken first?

CG : Right. yeah, it would totally go opaque, or black, or whatever before it started to produce images or text.

DW : Did they have any buffers or security firewalls - if you ask certain questions, it tells you it's unauthorized or anything like that?

CG : Well like I said, very, very seldom did you get a screen that was all blue or something that showed that you couldn't get to. But pretty much everything was open, and we had these same devices on the research vessel that gave us access to our own databases.

DW : So this is a prevalent technology once you get out into the space program.

CG : Yes, and they have much larger screens that they use for conferences and demonstrations.

DW : Well, obviously you encountered so much information on these pads. Was there any information that jumped out at you as being really significant that really shocked you, even from what you had already learned by that point ?

CG : It was really interesting that there were - the information was presented almost as if – going back to the college analogy - there were 22 term papers competing with each other, and each of these genetic experiment programs were presenting their information in that manner. They were somewhat competing with each other. They weren't all working - they weren't all hand in glove working together.

DW : Did this involve these human-looking extraterrestrials...

CG : Yes.

DW : ...splicing their DNA with ours, that kind of thing ?

CG : Yes, and manipulating our DNA. There was also a spiritual component. They are very much involved in a part of the experiment. It's not just them experimenting on us. They're a part of this grand experiment too.

DW : Did they have a goal? Why are they doing this? Why do they care?

CG : That I do not know. I don't know if they're doing it just because they can, if they're trying to create some sort of super being. But a lot of it didn't - why would they try to mix all of their best genetics together, and then manipulate us and our civilization to keep us down?

DW : How long do you think this program has been in action for?

CG : Of the 22 different programs, they've been going on for different lengths of time. But the genetic manipulation of what we are has been going back at least 250,000 years.

DW : Wow.

CG : But these programs, they vary in their length from 5,000, going - they're all different lengths of time.

DW : This doesn't sound like something that our secret Earth government or elected government would want these folks to be doing. Could we stop them?

CG : I don't think so. I mean, this is something that we've just recently been able to beg to get a seat at their table, to be a part of the discussion.

DW : So would these be negative-oriented extraterrestrials, or more neutral, not really the benevolent type?

CG : It depends on your point of view. It's all a [matter] of - it's perspective. It's hard to say, this group is positive, this group is negative out of all those groups, because they see what they're doing as a positive thing.

DW : You mentioned on your website something called LOC. Could you tell us what that is?

CG : The Lunar Operation Command is a facility on the back side of the moon that is kind of a diplomatic neutral facility that all the different space programs have access to and use. There's some people that are stationed there and work there, but it's more of a way station. People are coming and going from it all the time to go to their further out into the solar system and beyond, to go out to other stations, other bases, to go up to their assigned vessels.

DW : Walk us through your actual story-arc of how you go from your house and eventually end up on this research vessel out in our solar system, just a brief overview of what that was like.

CG : I was transported from my house in the middle of the night by conventional means to Carswell Air Force Base. Underneath Carswell Air Force Base in a secret area of the base there's an elevator that takes you very far down. And many people know about the tram system that runs underneath the United States.

DW : I've heard insiders call it sub shuttle.

CG : Yeah, it's a shuttle system. It's like a mono-rail going through a tube, and it's like a Maglev and also in a vacuum tube. I was transported from there to another location to where I was transported to the LOC through what some call a "Stargate" -type technology or portal technology. I ended up at the LOC, or Lunar Operation Command. And I was then put onto this manta-looking craft.

DW : Like a stingray shape ?

CG : Yeah, like a stingray or a manta ray looking craft. And with a bunch of other people. And then we were transported from the moon further out into the solar system.

DW : So there was some sort of hangar at the Lunar Operations Command.

CG : Yes, there's a series of hangers. This was the larger hangar.

DW : Okay, how big is this manta craft for conventional measurements ?

CG : About 600 people could fly in it.

DW : Wow, so it's pretty large.

CG : Yeah, it flew us to our destination.

DW : How long were you at the LOC before you boarded the manta craft?

CG : It wasn't long at all. There was - that's where I signed papers, even though I was too young to legally sign legal papers. And it was explained to me that I was doing a 20 year commitment. They called it "the 20 and back".

DW : Did it look like some futuristic set off "Star Trek, Next Generation" when you're in there? What did it look like?

CG : Just mainly real narrow halls and regular looking doors, but it was nothing - it didn't have Star Trek doors that swish, swish closed. It wasn't really super advanced in that way.

DW : So if you filmed the inside of it, you could easily convince somebody that it was just a building here.

CG : Oh yeah, definitely.

DW : What did the hangar look like? Did the hanger look anything special?

CG : The hangar looked very much like a Naval facility, like a mixture of a Naval submarine and aircraft hangar facility.

DW : Once you got inside the manta, how long were your flying for?

CG : Maybe 30, 40 minutes.

DW : And what was the next thing that happened?

CG : Next thing that happened was that I got to see the research vessel that I was going to be assigned to for the first time.

DW : How long were you on this space vessel for?

CG : I was assigned to the research vessel for six years.

DW : And you said that the whole term of service was 20 years?

CG : Yes.

DW : Is there a reason why they only kept you on the research vessel for six years?

CG : The intuitive empathy skill set was needed in other programs, so I was moved through multiple programs for the remainder of the 20 years.

DW : Could you give us an example of one of these programs?

CG : One example would be the Intruder Intercept And Interrogation program.

DW : What defines an intruder?

CG : Someone that's coming into the solar system or into the Earth's atmosphere uninvited, or without permission.

DW : And you would actually be able to apprehend these folks and ask them questions?

CG : There was a team that was a part of that program that would do that. I was present during the interrogation as an intuitive empath.

DW : And as you said before you're trying to detect deception?

CG : Right, somewhat. Sometimes when you communicate with these other beings it's called interfacing. Sometimes I was needed to interface, and sometimes I was there just to "read" them, read their emotions, and to see if they were being truthful, like a human lie detector.

DW : And consciousness works enough the same way that you can read extraterrestrials and it works the same as if it's a human more or less?

CG : Definitely.

DW : So you left the program after the 20 years of service.

CG : Other than some follow up work that they had me do, I pretty much ended my tenure.

DW : On your website, you've mentioned that there are five factions within the secret space program. Could you quickly delineate for us what those five factions are and just a little bit about what each one is like that makes them different from the others?

CG : Sure. I'll start with the oldest, which is "Solar Warden". They were started back in the late '70s, '80s, during the SDI, "Strategic Defense Initiative" - I think is what that stood for - just before and after Reagan. And then we have the ICC, the Interplanetary Corporate Conglomerate, which is corporations all over the world that have representatives in a super-corporate board that control the secret space program infrastructure that they have out in space, which is massive. We have Dark Fleet, which is a very secretive fleet that works mainly in the outside of the solar system. We have various BlackOps Military secret space programs that we put into one group. And then, we have this Global Galactic League Of Nations group that was somewhat of a carrot that was offered to all the other nations to have them maintain this veil of secrecy about what was going on in outer space by giving them a space program and giving them a narrative of "There's certain threats, or possible invasions, we need to come together and work together." And at the one facility that I visited a couple times, it looked very much like the TV show "Stargate Atlantis" where you had a real laid back environment, people walking around in jumpsuits with patches from all different countries off the world. They are almost completely outside of the Solar System as well.

DW : You mentioned the term the alliance a lot, and I think there might be some confusion there.

CG : There was the Earth Alliance. They have a completely different agenda. Their agenda is to basically create a new financial system and to take down the cabal and a few other things in their agenda. And then there's the Space Alliance, and it's made up of what started off with as mainly the Solar Warden faction and then defectors from the other secret space programs. And these defectors from the other space programs left their programs with their craft, and intelligence, and information and joined the secret space program alliance.

DW : What's the sequence of events that led to you becoming a whistle-blower and that has led to what we're now seeing with this push towards disclosure?

CG : I was contacted by an actual higher density ET group that has now been known as the Blue Avians.

DW : And avian means bird?

CG : Bird.

DW : So what would these folks look like?

CG : They're eight feet tall. They look very bird-like. They're blue to indigo in color with feathers.

DW : You say very bird like, though, are you saying they actually are birds with wings?

CG : No wings. They have a very human-looking torso, arms, hands, feet...

DW : So they're hominid. It's like a bird head on a human body?

CG : Yes, but they don't have a long beak like a lot of people are trying to depict on the Internet. It's a real soft, flexible beak, and when they speak they do a sign language or motion with one hand. And then they move their mouth around, and they communicate telepathically.

DW : So who are these Blue Avians? Where do they come from? Do they have an agenda?

CG : The Blue Avians told me that them and the other beings that they are working with come from sixth through ninth density and that...

DW : And what is a "density"?

CG : Everything around us is made up of matter, energy. Thought is all made of vibration. And it comes from a different vibration or frequency.

DW : So it's like another plane of existence?

CG : Right.

DW : Is it somewhere else in the galaxy or the universe, or is it around us?

CG ; It's not in a far far away planet close to the center of the galaxy or anything like that. It's all around us. It's real close and far away at the same time.

DW : And what is their agenda? What are they here for?

CG : They've been here for quite some time. They've been observing, but they're here, for - we're moving into a part of the galaxy that is a very high energetic part of the galaxy that's going to change the density of our solar system and our local star cluster.

DW : Is that something that they've told you, or is that something that in the space program you had tangible evidence of ?

CG : We had tangible evidence of that in the space program. That's been studied for some time, but that's something they told me as well.

DW : Okay, and if we go into a different density, what are these Blue Avians telling you will happen to human life as we know it now?

CG : That we're going to go through a transformational experience that is going to change us on a consciousness level mainly.

DW : What would that look like? Would we become more psychic, more telepathic?

CG : Yeah, I mean, there's a lot of theories. I haven't been told that we're going to be able to do this and that. I've heard a lot of different theories. I don't know if it's going to happen to everyone at once or if there's some people that are more spiritually evolved that are going to start showing these signs earlier. I don't have all the answers. I'm not a guru. I really don't have all the answers.

DW : So are these Blue Avians looking out for our highest good, or do they have a hidden agenda?
How do we know we can trust them?

CG : They're definitely of a positive polarity. From what I understand of sixth and higher density beings, they're not agenda-oriented as we try to project onto them. For our third, fourth density way of thinking, everything we do is agenda oriented. It's about making money. It's about manipulating people to do or think the way we think. We can't project that onto a higher density being and say that they're going to be behaving or thinking the same way. They are here with these giant spheres to help defuse these large tsunami energy-waves that are entering our solar system, and they're defusing this energy to where we don't get too much at one time and to give us more time to prepare.

DW : If they didn't use these spheres, what do they say would happen?

CG : That a lot of people would go mad, and there'd be a lot of chaos.

DW : And when you mention these spheres, what are we looking at? People are not seeing spheres in their telescopes.

CG : No. These are also other density, and a lot of people are thinking that these are giant spacecraft. And I'm almost certain after my many travels in these spheres that these are these spheres on a giant macro level. These little orb-beings are also these giant spheres.

DW : What are the orb beings?

CG : They're one of the five beings from the Sphere Alliance that are one of the higher density of the five beings.

DW : So you've actually had in-person meetings with these Blue Avians?

CG : Yes. My name was mentioned as a choice, as a delegate, to be a part of communications between this group, the Secret Space Program Alliance Council, and also to start speaking on their behalf with this old super federation council that I had sat in as an intuitive empath support as a young teenager. I was trying to talk my way out of this delegate position. I'm not a public speaker. I have a weak voice. I was giving all of these excuses why I should not be a delegate. I was giving these excuses after I had been brought to one of these massive spheres that are out in space, and I met this Blue Avian named Raw-Tear-Eir. And as I was trying to talk my way out of being a delegate, he walked up very close to me, put his hand on my forearm, and was communicating to me telepathically that I need to let go of all

the negative and quit thinking about the negative. And his hand was very powder soft on my skin. It's was the only time they physically touched me. And then he told me that what was important was the message.

DW : What is their message?

CG : Their message for humanity is that - and it's the tenet of many religions - we need to become more loving. We need to become forgiving of ourselves and forgiving of others, thus stopping the wheel of karma. We need to focus on becoming more service to others on a daily basis. And we need to focus on raising our vibration and our consciousness.

DW : Well you see a lot of people who are aggressive commenters on articles saying that the elite want to steer us into a one world religion. How would we be able to know that this isn't just another PSYOP to try to get us all marching in lockstep with some new controllers?

CG : Well that's what they said, and what I put on my web page is that you don't need to change your faith or your religion. You can use...these beliefs are the tenants of all the major religions. I mean, this is not really anything new. The time is short. It needs to be done. We need to start focusing on - if you're a Christian, if you're a Muslim, if you're a Buddhist, you can remain. That can remain your faith.

DW : So they're not trying to pose as the new God?

CG : Absolutely not. And one of the things that they have forced into my head is that I need to make sure that this does not become a cult or a religion. And I don't know the history of it, but apparently they've tried this three other times in the past. And each time their messages have been distorted, and humans have used it for control and turned it into cults and religions.

DW : Well obviously we've just gotten started here. This is really fascinating information, and I just want to say on a personal level that it validates so many things I've been studying for so many years and done as much as I can to try to put scientific evidence behind. So we got a lot more to talk about. We're just getting started, but I'm really happy that you wanted to do this and come forward. And I honor you for your courage and bravery. I know you got two kids. You gave up a six figure job for this. So this is really a major thing for you to come forward, and I really appreciate it. So, thank you **Corey**.

CG : Thank you.

DW : All right.

Cosmic Disclosure: First Encounter

Season 1, Episode 2

DW : Well **Corey**, this has been such a wild adventure. You started talking to me, basically, every day I think, when was it, maybe last October, 2014?

CG : It was around October, yes.

DW : Something like that. And when we first started talking about this you were just another insider coming forward. And then you eventually decide to release your name, because some people were figuring it out through investigation. And you got pulled into this alliance, which up until then, you really didn't have a whole lot of contact with it. Right? It was a new thing that happened after we started to.. after your name came out, you started to release more information.

CG : Right. My name was brought to this alliance and by this new group of Blue Avians. They mentioned me by name, that they wanted me to be a liaison between them and other groups. So I was, sort of, thrust into it.

DW : Had these Blue Avians ever spoken to the space program people before ?

CG : Yes, they were in contact with a person that I call by another name that's similar to his, Lieutenant Colonel Gonzalez.

DW : So Gonzalez, had you met him before this new sequence of events happened where your name was requested personally?

CG : No.

DW : Oh, okay.

CG : He was a new introduction to me. He had been in contact with the Blue Avians about the same amount of time I had been.

DW : Which was how long?

CG : Right a little over four years.

DW : Okay.

CG : He was in contact with them. He brought my name to the rest of the Secret Space Program Alliance.

DW : They told him your name?

CG : They told...

DW : And they asked him to tell the alliance that they requested you by name?

CG : Yes. And...

DW : So you hadn't been up there in a long time, right?

CG : Right. I hadn't been a part of that world in a while. And they investigated me. They looked into my background, and a lot of my service record had been redacted. And there were some things that concerned them. They really wanted one of their own guys to be a delegate or liaison between this new group.

DW : How is it even possible that a black ops group could redact information out of somebody's security dossier.

CG : These are hard coded. It's not supposed to be possible.

DW : So that must have freaked them out.

CG : Yeah, it's not supposed to be possible. These are hard coded.

DW : And I would imagine within their own system there's all kinds of rules and laws and precautions about who gets to be brought up there. And if you've been out of the loop for that long, they're not going to be too happy about bringing you up there, I would think.

CG : Right, and I was not someone that they had full confidence in that would toe the line and follow their every order. They wanted someone that they had full control over.

DW : Wow, so this name just gets dropped on them. And how did you find out that you were requested? Did you get contacted by Gonzalez, or did somebody else contact you?

CG : I was contacted by Gonzalez. I ended up getting picked up in one of the craft, one of the shuttle craft.

DW : Right.

CG : And I was informed that I had been selected by the Blue Avians, and I had been informed by the Blue Avians that this was going to occur. And...

DW : And how would that take place? What is the typical Blue Avian contact like?

CG : They will either appear in my house, or they have the little spheres come and bring me. Little orbs..

DW : You said they're eight feet tall, so how do they fit into your house?

CG : I have a high vaulted ceiling house. They have plenty of room to fit into my house. They've appeared in my house.

DW : Do they appear to have gravity weight? Do they bend the floor or something?

CG : No, they don't bend the floor.

DW : Do they float, or do they appear to be standing on the floor?

CG : No, they're standing there just like a normal person would be standing there.

DW : And it looks totally solid and real? It doesn't look like a ghost?

CG : Right.

DW : Wow.

CG : Yeah, they look like you could walk up and touch them.

DW : How did it feel the first time this happened? Were you shocked?

CG : Well, I mean I had been in contact with them for awhile, but it was more of a personal nature.

DW : Right, you said four years.

CG : For four years.

DW : So they had been doing this off and on for four years, just appearing in your house?

CG : Right, it wasn't a very regular contact.

DW : So Gonzalez gives you the message that they're going to bring you up there, and you said that a shuttle craft came. Could you briefly describe what the shuttle craft is? How does that happen?

CG : Yes, there's a small shuttle that fits five people, two crew in the front, and then three seats in the back. It's a triangular shape and goes up into somewhat of a pyramid kind of shape. And the side opens up. You get in. When it would float in the backyard, I'd go into the backyard to get in. When you'd step in, it would dip down and move a little bit.

DW : And so it doesn't have landing gear?

CG : No. But it would, there were -

DW : What was the color?

CG : It was the black grayish color that you would see that you associate with the stealth bombers that a lot of people are familiar with. Within a matter of a few minutes, it would zip up to the LOC.

DW : And the LOC again is?

CG : The Lunar Operation Command.

DW : Had you experienced this before?

CG : Not with this. This particular shuttle was new to me. This was... there were some newer technology that I was seeing from when I was in prior.

DW : So take us through what happens next. Did you have windows you could see you flight through, or was it all blocked out once you got inside?

CG : Well, at times they could make the panels go transparent where you could see out, but usually it was such a short trip there was no need for you to see out.

DW : How long did it take you to get to the moon?

CG : Three to four minutes.

DW : Wow, so let's take it from there. What happens? You've been invited to be this delegate for Blue Avians. You get brought up to the moon in this shuttle craft. What was going through your mind? What happens next?

CG : Well, I didn't - I really didn't know what to expect. I was never really given, you know, a lot of intel beforehand. I got dressed real quick. I grabbed the quickest cap I could find off of the rack, which happened to be a hat I got when I went to Houston with my family.

DW : This is now while you're still in the house before you got picked up?

CG : Yes.

DW : So you got dressed.

CG : And it was when we toured NASA down in Houston, Texas. I had a NASA shirt, a NASA hat we bought as tourists. And I put on the NASA hat. And the night before - I didn't even think about it - my daughter is wanting to paint faces. She likes to paint faces. And she wanted to paint my face, and I knew I had that meeting the next morning up at the LOC. So I was like "No, I'm not going to do that.". So she was just like "well, can I paint your hand?" And so I said "Okay". So she painted a green dinosaur, Tyrannosaurus Rex on my hand, eleven year old. So I didn't wash it off, and it stayed on all night. And it was pretty dried. And that was still on my hand. I was not looking all dapper and sharp for this first encounter. As I was getting off the craft, there were other craft. And in this particular time, when I got on the craft, there was another person on the craft that was wide eyed. It was a lady, and she looked like she had just gotten out of bed.

And she was like, isn't this exciting? Isn't this wonderful? And she was just ecstatic. And it was just her and myself in the three-seater in the back when we went up. And then we just -

DW : Are there two pilots in the front? Is that two -

CG : Yeah.

DW : So two people have to run it.

CG : Right. Two people were in the front. And then the three - usually three open seats in the back. And usually it's just me getting in. This one time I was surprised when it opened to see someone else in there. And when we land in the hangar, we disembark. And there are a lot of other people disembarking for this conference that were just kind of average Joe's. And they were all starting to file into a line to go into one area of the VIP area of the Lunar Operation Command. And I was met by Gonzalez who walked me past them to - there was a conference room right next to that. And he walked me right into the very front of the very crowded room and told me to stand. He said, stand right here. And it was almost in the very front of the conference room. So I stood there. I put my thumbs in the front of my jeans feeling very weird, because I could feel all the eyes on me. So then I looked up and started to look around, and I saw all these people in these swivel chairs in a cathedral - like conference room that went very high up. The room could hold around 300 people. And there were people from all over the world. There were people in - politicians in India up there with the cut of the collar.

DW : Leather jacket?

CG : I guess. And people that looked like they were from that area of the world. There were people in different military type uniforms, different type of Air Force type jumper suits, and just a wide variety of people. And some of them looked like they knew each other. They were clicked off, talking to each other, or murmuring to each other. And I was standing up at the front trying to be inconspicuous as I could being at the very front. I have no idea what I'm doing, why I'm there. And I catch the attention of some of the people in the front. And being gruff military people, they start asking, you know, who the heck are you? I'm cleaning up the language. Who the heck are you? What are you doing here? I said, I was just told to stand here. And one of them said, why are you wearing that ridiculous cover? Referring to the hat I was wearing. They said, take that off. I cleaned it up again. I took my hat off, and just flipped it and spun it onto the floor. Another one asked, why do you have a painting of a reptilian on your hand? And I looked at that, and I tried to wipe it off. But it was too dried. It smeared a little. And I was really starting to get nervous at that point. I had no idea what was going to happen.

DW : You just up there being heckled.

CG : I was starting to get heckled, yeah.

DW : You were alone on stage?

CG : I was alone on stage. No prep. I was just walked there, told to stand there. And then all of a sudden everybody got quiet and just filed to their seats and started looking behind me.

And I didn't see a flash, anything strange, but I'd look behind me. And there was standing one of the Blue Avians that I've come to know as Raw-Tear-Eir. And I know one of the other sphere beings that I had never seen before that we've come to now call the golden triangle head just because we've not been given a name or anything. They're not real big on names of but...

DW : There's a golden triangle on the top of their body?

CG : It's head was a golden upside down triangle, huge head with huge eyes that were blue. And his shoulders were very thin about the same width as this head. He was about 10 feet tall, couple feet taller than the Blue Avian. And his arms were extremely long and thin. And his legs were too. No clothing. No sex organs or anything like that. And the skin was brown with a golden sheen, and had three fingers, and it was standing on three toes that were supporting it like this, almost like tripods. And it was there, didn't communicate, nothing. It just stood here. And it just seemed very like it didn't have any bones in its body. Just very weird apparition looking. And then Tear-Eir began to communicate to me telepathically with his hand raised... doing good... the communication.

DW : Where you looking at him, or were you looking at the audience?

CG : I was looking at him. I mean, that got my attention, just like it got the attention of the audience.

DW : Had they seen anything like this before?

CG : No one except for Gonzalez and a very few had seen the Blue Avian. So this was their first encounter with a Blue Avian. And all of them were there knowing that they were going to have - this was going to be. Everyone else knew why they were there. I was the only one that really didn't know what was going on. And that's how, for some reason, that's how they work. They throw me into situations with me not knowing what's going on a lot of the time. It's odd, but I've learned to roll with it.

DW : Well, I guess nobody's heckling you once they showed up.

CG : No. And then at that point, I then was told by Tear-Eir to turn, and introduce, and repeat everything that he said word for word, to make sure I repeated everything word for word, and not to change anything. Everything had to be exactly word for word. So I turned to the audience, and I know I

don't remember exactly what all he had me say in the opening. But then he opened it up for questions. And there were a number of questions. A lot of them were technical. They were things that I didn't understand what they were asking. Tear-Eir did. And I didn't understand what I was saying back to them. But there were some interesting questions that I remembered, and when I got home I immediately wrote it down so I'd remember. And I've got a list of those if -

DW : Yeah, let's. If you have something to read, we'd love to hear it.

CG : There was one person that was in uniform, and he asked if the Avians were the rumored Ra from the Law of One, which was interesting that they would ask that. And the only response Tear-Eir had me give back was "I am Raw-Tear-Eir." That was the only answer.

DW : Well as you know, in the Law of One, every answer to every question starts with I am Ra. So that's pretty obvious.

CG : And so that's - the person looked a little disappointed with the answer, but it was on to the next one. One of the people that looked like they were more from Earth, that looked very important, very dignified asked why they needed so many spheres, why were there 100 spheres in the solar system, and why do these beings need these larger ships? And Raw-Tear-Eir, or I just call him Tear-Eir, had me reply in this manner. "We require no conveyance. There are far more than 100 spheres that are spaced out equidistantly throughout the solar system. They are what you would best describe as devices and are in place to buffer the tsunami of storms of high charged vibrational energies entering your solar system, so they do not affect your star, planets, and native life in an adverse way as your system enters into this part of the galaxy."

DW : Wow.

CG : Another person asked, "If you are not living in the spheres, where are you going when you dematerialize?" And his answer was, "Many of us adjust back to our reality while others remain in what you refer to as a cloaked status and observe activities on Earth, and your other colonies, and facilities undetected by those around them." So they're out of phase or cloaked. And the others go back to their reality. They're not hanging out in these spheres. Another person asked, "Why there was an intervention recently after there was a defection of other secret space program groups with actionable intelligence that could have made a major difference and helped them win major victories?" The response to this was info that the various SSP groups understood, but I didn't at that time. Since, I

found out what this was regarding. And his response was, "Since the defections there have been changes in the tactics that have were unsettling. The extremely destructive incidents on Mars and Earth that caused the large loss of life of innocence was a disturbing sign that these new tactics were taking the alliance in a direction where collateral damage of this magnitude was considered acceptable."

DW : What kind of magnitude?

CG : We can get into it later, but on one of the Mars facilities, there were a quarter of a million, I think, people that died.

DW : In a military strike that the alliance new defectors conducted?

CG : Yes, without permission from the council. They acted on their own.

DW : You said they had actionable intelligence?

CG : Right, from defectors from other secret space programs.

DW : So they couldn't just do a strike like this any time they want?

CG : No, it was actionable intelligence that they had a short window if they were or not have an operation. And they chose to act on their own.

DW : And Tear-Eir and his associates were very upset about this?

CG : Yes. There are a couple of secret space program groups that have been blocked from reentering the solar system since the outer barrier has been erected. And some of the people have been lobbying trying to let some of them back in. And this was one of the people that raised the question that they wanted the galactic league of nations - I've been referring to them as a NATO type SSP group, but that's the first time I had ever heard them referred to as a galactic league of nations - to return. They stated the group would return under any demands that the sphere alliance came up with.

DW : How much of the Galactic League Of Nations do you think was outside our solar system when the barrier went up?

CG : Almost all of them.

DW : These are humans, though?

CG : These are humans.

DW : From here?

CG : Yeah, and they were almost completely based and operating outside of the solar system. So they're almost completely out there and can't come back. And the response - the request was denied. And it was communicated that all of the travel within and without of the solar system will remain suspended for the foreseeable future. And this did not go over well with many, because a lot of the people present were really wanting to petition to allow this one group to be able to come back. Because they saw them more as a neutral group.

DW : Do you think with all the intelligent civilizations that the space program people have access to that those civilizations knew that this kind of thing could be done, that a barrier like this could be built around a solar system? Because it seems like it caught them quite by surprise.

CG : Everyone was caught by surprise.

DW : So this is not a normal thing to happen?

CG : I don't think so. One of the few esoteric questions was asked by one of the military people, which was strange to come from a military person. They asked - this is a question. This is something that goes around, so they must have access to some information on the internet. "Is there a soul trap set up for us after we die?"

DW : A soul trap?

CG : Yeah, a soul trap. And since then Gonzalez said he was referring to a white - there's a soul trap white light that people are talking about when you die. If you go to the white light, you get stuck in some incarnation soul trap or something.

DW : Well Art Bell was saying that all the way back in the '90s. Don't go to the light. It's a trap.

CG : Right, well that's what this question was referring to. I really didn't know what it was talking about at the time. And the answer came back from Tear-Eir, "The only traps we encounter in life and after are the ones we have set for ourselves. The idea that there is a soul trap at the end of a white light was a PSYOP and a distortion set in place that we can then create with the creative force of our

consciousness. This is the intent of the creation of this distortion." See, this is how they talk. It's very frustrating.

DW : Did they ever explain to you why they have to communicate that way?

CG : No, they don't. The person -

DW : What do they tell you if you try to get more specific?

CG : They just continue on with what they were planning on talking about. Sometimes I'll ask a question, and if it's not pertinent or whatever, they just keep on going. The person asking the question do not seem satisfied with the explanation. But that was pretty much the end of it - of the questions I wrote down when I came home. I just wrote down after that most of the questions were of technical and tactical subjects that I had no idea of what they were asking or what I was - the content of what I was repeating back.

DW : In general, what do you think the alliance was expecting out of these sphere beings? Are they expecting military support to be able to create full disclosure breakdown of secrecy so that - what were they wanting?

CG : In the beginning, I think they were expecting what a lot of people out there are expecting. They were expecting them to come in, and kick butt, and take names. They were expecting them to come in and be saviors, to come in and give them technologies to, offensive technologies, to wipe out the enemy, or to come and take these off world beings off in shackles, and to help come down and take the elite out. But they were disappointed as well. And they were dumbfounded that they expected this to be a fully military - they were military people, military minded. And them coming in with this, what they called a hippie message of love, and forgiveness, and raising your consciousness, just did not compute to these people with the way they think. So a lot of them were very concerned and very taken back.

DW : When you say there were a lot of technical questions that you didn't really understand, was the overall gist of it seeming that they were trying to enhance their war footing and have tactical strategy?

CG : Yes, it was tactical, and it had to do with offensive capabilities and wanting to use their ability to know future events, all these different temporal kind of questions, things that were far above my head in understanding. because I didn't know all of the logistics going on, that they had going on behind the scenes. So I didn't have any base of reference of why they were asking the questions.

DW : And the Blue Avian said, Tear-Eir said, that there's a tsunami of energy coming into our solar system?

CG : And since then, he said that these energy waves are coming in like ebbing and flowing. They're coming in waves, as well as our solar system, our local star cluster, is in the torsion field of the galaxy as we are entering this area of the galaxy, this high energetic area of the galaxy.

DW : Did he say anything about what the immediate short term effects of that would be as a - like what would happen to us as a tsunami comes in? How would we notice it?

CG : Well, if they were not defusing this energy, there would be a lot of really catastrophic sun activity, and a lot of really bizarre behavior in humans and animals, and really bad weather, earthquakes, all kinds of things that these spheres diffusing. This energy is supposedly alleviating for us.

DW : What would be the bizarre behavior? What might we see?

CG : Basically like end time madness type of - people just not being able to handle it, handle the energetic change.

DW : So the tsunami has an effect on the mind somehow?

CG : On the consciousness, people's consciousness. You would be waking up, and instead of your local area hearing of one or two shootings every night, you'd wake up and hear of all kinds of shootings, and riots, and crazy stuff going on, people being reactionary and acting bizarre for no apparent reason.

DW : I think most people feel like their thoughts are their own free will, and they don't have any - there's no other influence on how they think and feel other than what's in their own mind.

CG : We're all connected. We all have a joint mass consciousness that is affected by the energetic background noise or background energy of the cosmos.

DW : What is the effect that will happen as this continues? If they're stopping people going crazy, then what are we gaining as this energetic change continues?

CG : Well we're gaining time right now to raise our consciousness to become - well, their message is to become more loving, more forgiving of yourself and others. And they say that stops the wheel of karma, and that we should focus on becoming service to others on a daily basis, not being so focused

on ourselves and our own self needs, but on helping others, not being a doormat to others, but to try to be empathetic and help others, and to daily try to raise our consciousness and our vibration.

DW : So they're not trying to pose as the new god.

CG : Absolutely not. And one of the things that they have forced into my head is that I need to make sure that I do not come across as any type of guru, that I need to remain humble, and that I need to make sure that this does not become a cult or a religion. And I don't know the history of it, but apparently they're tried this three other times in the past. And each time, their messages have been distorted, and humans have used it for control, and turned it into cults and religions.

DW : Can you give an example of where you stepped out of line, and they spanked you?

CG : Well, there's been times when I have lost my temper with haters, and they've told me that during this time of high energy, karma is more immediate. And I suffer some immediate karma, open myself up attacks. And they'll have a talk with me that, you know, I need to practice what I preach, focus on the words that I'm saying, and I need to try better to embody what I'm saying. And become more loving, forgive others, it sounds easy. But that's a very difficult path. It is very...

DW : Well, it seems like it's the opposite of what the elite believe.

CG : Well, it is. And anyone that's tried to walked that path, you stumble quite a bit. And being human, it's hard to love people that are hating you. And it's hard to forgive people that are spitting in your face. But it's not a easy path. But if you want to raise your consciousness and become a higher vibratory type of person or being, that's the path you gotta take.

DW : Did they tell you there's a relationship between consciousness and physical reality?

CG : Absolutely.

DW : How does that work, according to what they told you personally?

CG : Well, it's the same concept that has been used to enslave us.

DW : I don't understand.

CG : Well, our mass consciousness has been used as a tool against us to keep us enslaved. The powers that be will use media to plant a seed in our mass consciousness, and then later on through mass media,

or false flags, or whatever cause an incident to cause us to emotionally give it energy and the masses to, through our mass consciousness, to create that situation, and make it happen.

DW : So you're saying that's like imagineering?

CG : Right.

DW : They're actually trying to cultivate this power that we have to manifest outcomes that they might want?

CG : Right. The powers that be fully understand the power of our consciousness, and they understand that everything around us - our thoughts, light, energy, matter - are all states, are all vibratory states. And our consciousness is a vibratory state. And our joint consciousness is a very powerful co-creative mechanism that has an effect to all of the other vibratory states around us. And once we learn to harness that, we can change reality, and especially as we're going into this higher vibratory area of the galaxy and where our consciousness is changing, becoming more higher vibratory, we're going to become more of a force to deal with for these elites or any other group that want to try to keep us in a box.

DW : You said that 40 different - there's 22 different genetic programs going on. And so we have all this DNA from other intelligent civilizations. What happens with all that mix and match of DNA in us as we go through this change?

CG : Well what has occurred from this big hodgepodge in mix is that we have a spectrum, a wider spectrum of emotions than most beings out there. They have the same emotions we do, but because of all the tinkering that's happened with our light bodies and our genetics, it's not just genetics. We have a wide spectrum of emotions, which is a blessing and a curse, because I mean, right now we can control those emotions. And it's affecting - and our consciousness level is not controlled, so we got a mess right now.

DW : So if someone has a judgmental look on their face and looks at us like, [SCOFFS]. Because of this genetic mix and this spectrum of emotions you're talking about, does that mean that we are going to actually have a stronger emotional reaction than other intelligent civilizations normally would?

CG : Yeah, we have a stronger emotional reaction to just about everything than other societies do, because of our makeup.

DW : It seems like that could be a tremendous weakness.

CG : It's also a great thing once we learn how to control our consciousness, because emotions are like an activator in our consciousness. They work hand in hand, and that's what helps activate our consciousness. And we can become very powerful co-creative beings and create a wonderful new world once we learn how to - once we're not being manipulated, and once we learn how to manage our emotions and our consciousness.

DW : If the sphere being alliance is not allowing what we're calling the good guys, the alliance in the space program, to actually create military strikes, how do they think that anything's ever going to change? Wouldn't the alliance perspective be that they need to attack these negative groups of extraterrestrials that are still here in order to ever change anything?

CG : Yes, they have wanted to go the full military route, but negative begets negative. You can't get a positive from a negative. They've been given extraordinary technologies that are defensive in nature, not offensive.

DW : It's the Alliance, the space alliance?

CG : The Alliance., the Secret Space program Alliance has been given defensive technologies, but they have been told not to do any more of these strikes that cause large losses of life, not to destroy any more of the infrastructure that is going to be handed over to a post disclosure civilization that will be the foundation for a "Star Trek" type civilization.

DW : Well disclosure would be a really key word there.

CG : Yes, full disclosure is what they're going for.

DW : So these sphere beings are helping us get to disclosure?

CG : Right, that is the goal. They want for humanity to free themselves through disclosure and through us rising up and freeing ourselves. And hopefully - and it's going to be messy, because a lot of people are going to be angry. There's going to be some messy parts but they want us to do it in a way that's going to be a foundation for a whole new era for humanity.

DW : Well this is a really fascinating subject, and we are only just getting started. We're going to do a whole series of episodes. Obviously, there are so many questions, and we're just cracking the lid off of

this thing. But this is very fascinating, **Corey**. I applaud you for your courage and your bravery in coming forward and being willing to do this. And I think you're a hero, and we all owe you a debt of gratitude. So thanks for being here, **Corey**.

CG : Thank you.

DW : All right.

Cosmic Disclosure: Lunar Operation Command

Season 1, Episode 3

DW : I'm your host, **David Wilcock**, and I'm here with **Corey Goode**. This is a very interesting conversation that we're having regarding the Secret Space Program. I want to emphasize once again that this material is highly controversial, and that you probably have not heard anything like this before unless you've been following what we've been talking about. I do want to make it clear one more time, that I have investigated this subject for many, many years. I've been in contact with insiders for over 20 years and I've spoken to dozens of people with different types of classified clearance. And my conclusion has been that there very much has been an industrialization of our Solar System and beyond, by what you could call the government or the military, depending on how you want to word this. So, **Corey**, it's good to have you back again. And it seems like, from what you're saying, the LOC, of Lunar Operation Command, is like the focal point for how Earth is then connecting out to the greater space Program and the cosmos in general. So, tell us a little bit more about the LOC. I guess, first of all, what does it look like as you're flying into it?

CG: Well, you can tell it's been built and added onto quite a bit since the '50s, It's built into the craters and into the rocky area to where it blends in somewhat. Some part of it, is built into the rock. Very little of it is above ground.

DW: Oh! Okay.

CG: Most of it, I have not has access to. I have seen a diagram to where it is somewhat of goes into a bell shape further and further down you go and I've only have access to upper levels.

DW: So, even though it's a bell shape, you don't actually see the bell on the surface of the moon.

CG: No. It's like looking down at the top of the bell or the tip of a pyramid. You just see the smaller top or the tip of the iceberg, I guess you would say. The rest is below and spreads out as it goes down.

DW : If there are this many craft going to and from the LOC and you say it's on the dark side of the moon, how could it possibly have been kept secret from us? Couldn't people with their telescopes see all these ships coming and going from the moon?

CG : People do see that. There's actually another base on the back side of the moon that belongs to human beings. It belongs to one of the Secret Space Programs called Dark Fleet, that a lot of people see craft coming from. I can give more of a location of that one. If you're looking at the moon, it's at about 10:00 position. People have filmed and seen flurries and swarms of craft leaving and coming from that area quite a bit... amateur astronomers with video cameras hooked up to their telescopes. This is something that has been seen.

DW : Is there anything on the side of the moon facing us of interest, or is it all being kept on the back so that it's less apt to be seen in the moon's surface.

CG : Most of it is on the back. There are areas on the front side where craft come out and there are entrances. There are also areas that are, by ET groups, that are covered by a sort of hologram shielding that prevents us to see it. Most of it is on the back side of the Moon for obvious reasons, for those on the planet's surface that are not meant to see the stuff, won't see it.

DW : When was the LOC actually built?

CG : The LOC was built onto an existing NAZI facility that had been built in the latter part of the '30s and '40s.

DW : So, it goes that far back.

CG : That far back. Once the industrial might of the United States became involved, they really started putting a lot into it and built it out like crazy. They started really building in earnest, in the late '50s on it.

DW : Yeah, and I want to get a lot more into the history of the space program in some later episodes. For right now, let me ask you another question. If we had this all the way back in the '50s, then why did we do the Apollo missions? Why did we land on the moon? What was the point?

CG : There are various levels of programs. There are some in NASA, and there's NASA equivalent military programs that are what they think, are the most cutting edge. And they think they are at the top of the totem pole as far as security clearances and "need to know" of what's going on in the solar System.

And these people would literally get into fist fight with you were to challenge them and tell them they weren't. So they're ... I guess the lie has many levels and the people at each level are told they are at the top. And it's not the case, but they believe it, just as everything is completely compartmentalized. In each compartment, everyone think they're doing the most important cutting-edge work and have the broadest knowledge and all other compartments and groups are below them.

DW : I guess if you can make someone feel special then they're going to work harder because they think they're the cream of the crop.

CG : Right, Hubris

DW : Yeah. Do you think, the Apollo missions was a money laundering operation?

CG : Very well could have been part of it, to channel a lot of that money into the Secret Space Program. The people that were running those programs on the lower level really believed in what they were doing and really thought it was cutting-edge and the highest technology we had.

DW : Do you think those employee could have had information withheld from them about how expensive what they were working on actually was?

CG : Oh yeah! They deceived on an intelligence and every... They were deceived on every levels.

DW : So do you think it could be maybe even only 10% as expensive as what they told us it was?

CG : That would be speculation. I would have no way to know, but...

DW : But it definitely could have provided "black cash" to develop out the Space Program even more.

CG : Yeah. Through all different ways... that drugs, all kinds of way they have of coming up with cash to build out that infrastructure in the beginning.

DW : Do you think that NASA knew anything interesting at all that we didn't know in the mainstream about the moon?

CG : There was a lot that was discovered during the Apollo missions. In the beginning they discovered that it was not a real good idea to slam one of their landing modules into the moon to test the instruments they placed on the moon to check for moon quakes.

The moon is a very strict zone that is like a giant Switzerland. It is a very neutral zone and hitting it with that projectile was a very bad idea. And from what I read, they were warned not to come back.

DW : It's strange that you would say that the moon is this neutral Switzerland type of area because it's right next to the Earth. If it's our moon, shouldn't be our property and we get to have control over the moon?

CG : No.

DW : It doesn't work that way?

CG : No. If you've seen, sort of, the maps of Antarctica, how it's sliced up amongst all the nations. The back of the moon is that way, too. And all these different regions are pretty much owned and inhabited by different ET groups.

DW : Really?

CG : And there are some groups that have bad blood and have warred with each other going back many, many, many thousands of years, but they have installations that are just a couple of kilometers away from each other. And they have been there for many thousands of years, in peace.

DW : There's a lot of moons in our Solar System, so why is the moon right next to Earth so important to these folks?

CG : It's a perfect observation and area to leave, to come to the earth and back for doing their experiments.

DW : So a lot of what we could call extraterrestrials are not very far away and they're coming and going from a place that's actually right nearby.

CG : Exactly.

DW : Does this get back into what you were talking about in our previous episode, about the delegation with this so-called experiment where they were running these 22 different programs?

CG : Right. And all of the different ETs... this includes human-type ETs and the non-human-types, types that do not particularly like each other very much. There is some sort of diplomatic agreement about the moon. There is something very special about the moon being a very diplomatic neutral zone. None of them will violate that.

DW : So you're saying in this Super Federation Conference, where you said there's at least 40 different groups, they're not all in agreement on what they're doing. They all have their own programs or their...

CG : Own agendas.

DW : So these delegations were like a way of them kind of working out their arguments and finding common ground somehow?

CG : Right, not stepping on each other's toes all the time with their different agendas.

DW : How could these groups that have warred with each other in the past possibly be able to tolerate each other's presence on such a small – the moon is only 2,160 miles wide, so how could they tolerate that?

CG : It's something that has been going on for thousands of years. They've set up this diplomatic neutral zone that not even the worst of them will violate. None of them will violate it. It just is not - It's something that I've heard it say - it is not done.

DW : Is there some sort of enforcement, some sort of military that polices it or ...

CG : It doesn't have to be. It just – no one has to enforce it. It just isn't done.

DW : Well, that would imply that in the past, something happened that was so horrible that they learned from their mistakes, I would think.

CG : Right. There's areas on the moon where there's a lot of debris from other battles and things from ancient times.

DW : They didn't clean it up?

CG : No. They left it there as kind of a memorial, or a testament of what happened in the past. And the stuff is still there and it's usually off-limits.

DW : So it might be like the idea of how silly the nuclear arms race is, where you've got two countries fighting over who's got more nukes when even a small percentage of that arsenal would wipe out the whole planet.

CG : Yeah.

DW : So these folks would all wipe out each other out if they want to war because they probably have weapons that are much greater than nukes.

CG : Right. They can destroy entire planets.

DW : WOW. So, the LOC, is that just one small part of all the habitation that's on the moon?

CG : Right.

DW : It's not really a focal point, except maybe for us, for Earth?

CG : Right. It's a focal point for human activity.

DW : So, other ET groups would have their own versions of the LOC for them, which would be like their focal point.

CG : Exactly.

DW : They're not using our LOC as their focal point?

CG : No. No, no, no. I have not seen ETs at the LOC, other than when members of the Sphere Alliance have appeared.

DW : So real quickly, what is it like when you are in the LOC? Do they have apartments that you can go to once you get inside? Is it just wide open conference rooms and little chairs? What happens when you go inside?

CG : Well, until recently I had never been to the VIP area. I had always been to just the area to where they have kind of, not really small apartments, but small little dwellings to where it has two to four bunks. The halls are really narrow. You move over to the VIP area, the halls are wider, there's wood paneling on the walls, like cherry-wood nice walls – very upscale. It's a dramatic change when you go from one area to the VIP area.

DW : Could you wander around and try to find a restricted area, or do you have military escorts that lead you around. How does that work?

CG : Well, you're allowed certain areas. There are marks, paint lines, on the floor that a different color that lead to different areas.

DW : So, if you were red, then you'd just walk, follow the red line to where it leads to?

CG : Right. And, like I said, I've only been... The top floor is where most of everything takes place. The next two floors were the medical and some other more advanced medical stuff take place. I have never been further down than those.

There are some people recently that have been taken on a tour that have gotten to see a lot more than I have.

DW : One of the thing that obviously is the most interesting to folks is the idea of an alliance. So, we covered that briefly, but I'd like to sort of, sketch-out for us in more detail. What is the Alliance? Was it there at the beginning of the Space Program or did it form later on, and what are their goals, that kind of stuff.

CG : The Alliance, it kind of formed slowly over time. The Solar Warden was more of a group that was dated back to the SDI era and a little bit earlier.

DW : Strategic Defense Initiative.

CG : Right.

DW : Star Wars.

CG : Back in the late '70s, '80s, and they were getting upgrades up into the early '90s. But they were pretty much more of the aging fleet.

DW : What was the Solar Warden's original responsibility?

CG : They policed the Solar System from intruders and...

DW : That would be groups that are not part of these 40 that are the Super Federation?

CG : Right. And also somewhat of a space-traffic control, air-traffic control. They took care of that.

DW : Could some ET group just interfere and invade with vastly superior weapons and technology? I mean, how could a group from the '80s be able to police our Solar System against potentially anybody that could try to invade here?

CG : Well, they wouldn't have been able to hold their own with a large invasive force, but most of the groups that passed through were only in maybe one to a handful of vessels. There are so many different groups that pass through our area.

DW : And, I would guess it's sort of like gang warfare, where the 40 ET groups that sort of, claimed this as their turf, with whatever level of technology that they have, they're also going to defend their "home turf" from an invasion.

CG : Right.

DW : So, Solar Warden is not necessarily meeting a tactical force. They've not having a weapons-up fighting stance when you say they are policing the Solar System – or are they?

CG : They would engage small numbers when they had to, but they were not ever a huge force to be reckoned with.

DW : So, most of these unwanted entrances into our Solar System, would be more small groups of ETs or single craft that are trying to be sneaky.

CG : Right.

DW : Trying to slip in?

CG : ... marauder groups that would come in and do "hit and runs", to come and take things and leave.

DW : OK. So, where does the Alliance come into play, now that they are talking about the Solar Warden? You said Solar Warden got started in the late '70s and they got a lot of the Star Wars technology?

CG : Mm-Hm (Yes)

DW : How does this relate to the Alliance exactly?

CG : OK. Well, they were kind of the root group that formed the alliance. Now, they're made up of breakaway or defectors from the other space fleet groups and some of them are from various Black Ops Military Space programs. You have the ICC, the Interplanetary Corporate Conglomerate, which is pretty much the largest. They own pretty much all the infrastructure out in the solar System. You have...

DW : And what corporations?

CG : Just about every aerospace and other than aerospace, it's a huge amount of...

DW : Lockheed, Boeing, McDonnell Douglas, Hughes Aircraft?

CG : Yes. Just, all of the above. And not just American Corporations. And then you have the Dark Fleet. They are a very secretive fleet that has very advanced technology and they are predominantly outside of the Solar System all the time. Then there was this UN-type fleet from just about any country you could think of, and they...

DW : Countries on Earth, you're saying.

CG : Earth countries. And they seem to be a lot more of a laid back, and not really a huge militaristic group. As Solar Warden has started pretty much a Cold War, they started to fly in front of the International Space Station to "accidentally" show their vessels, little things like that in the beginning.

DW : If Solar Warden is going to try to create disclosure, where obviously the other parts of the Space Programs don't want it, couldn't that lead to a shooting war between these factions?

CG : Yes. It was on the brink of that when the Sphere Alliance, the Sphere Being Alliance, went into an active mode and made contact with the Secret Space Program Alliance, which had just started accepting defectors from some of these other groups to where it wasn't just the Solar Warden group anymore. The alliance was made up of defectors from the other programs, as well. So, it's a hodgepodge of defectors from all the space programs that have a common goal of ending the tyranny

on Earth of basically the secret Earth Government that controls the “Babylonian money magic slave system” and to bring to Earth the technologies that we have developed that has free-energy, all kind of medical technologies that will heal just about anything you can think of, clean up the environment. Overnight, these technologies would collapse the financial system and there would be no need for a financial system. And they want to bring this to Earth and to also do a full disclosure of all of the crimes against humanity that all of these elites have been doing over many, many years. That’s their goal.

DW : So, when did the Secret Space Program Alliance starts to have these goals in mind and begin to find action on them, to your knowledge?

CG : To my knowledge, they started forming these idea in, probably, the late ‘90s and were really starting to act on it in the early 2000s, where they were really trying to cause accidental disclosures by flying in front of live (video) feeds, trying to get people to ask questions.

DW : How much contact does the Space Program have with what’s here on Earth? Could they tune-in (to) cable television and watch TV and see what’s going on with our shows?

CG : Up until a certain time period, there was zero. All communications to Earth were blocked

DW : Really?

CG : Yeah. There was no... After the internet, internet access was blocked. There is internet broadcast throughout the Solar System.

DW : Internet from Earth, or they have their own internet in the Space Program?

CG : They have their own internet and access to The Internet.

DW : Oh! They do?

CG : Mm-Hm. A lot of time, it’s read-only.

DW : Read-only?

CG : Yeah.

DW : I would imagine that only the most trusted people would be able to actually upload something to the internet that they could be trusted not to leak the truth.

CG : Right. Back when I was assigned to the research vessel, we had all... Any radio or television broadcasts were blocked. We were not allowed any real-time or close to real-time news.

DW : So, the Alliance is aware to what's happening on Earth? Some people at least in the Alliance know what's going on here.

CG : Right. After they finally got to a point to where they broke away, they opened up information to where those that were in the Alliance now had access to information. And seeing what was going on gave them even more incentive to want to bring this information, this technology to humanity.

DW : What would the average person's life be like if the Alliance's goals are met? On Earth, what would that life be like?

CG : It would be no different than the "Star Trek" era, what you've seen in "Star Trek".

DW : So could people have a portal station that they could go to, where instead of flying through the airplane that you'd be able to take some kind of Stargate-type system to wherever you wanted to travel?

CG : Sure. Yeah. There's replicators. There would be no starvation. Literally, the deserts could be turned green with desalination of water.

DW : What about all the plastic floating in the ocean, these big giant gyres of waste material?

CG : Matter is easily changed into something else. It's just matter of knowing how, the technology to do so. And we have that technology, it's just not being shared.

DW : Some people might be really freaked-out by the idea of not having money anymore. They're going to say, that's socialism, that's communism. That's going to get us under even more control because nobody will have any money to resist this new thing that they're trying to do.

CG : That's the way we're programmed.

DW : How would you think that, that's not the case?

CG : I mean, if you want money that badly, you can use a replicator and replicate some silver or gold or replicate yourself a \$100 bill, if it makes you feel comfortable, and put it in your pocket. There will be absolutely no need for any type of financial give or take.

DW : I would think that, the typical old-school politician mentally would be that if you gave everybody to Earth this kind of stuff, that they would all just want to drink beer and nobody would want to do anything, and they'd just be hanging around and it would kill them. It would ruin their lives.

CG : Well, there's going to be a transitional period where people are going to go probably a little bit nuts for a while with the technology.

DW : I mean when people win the lottery right? It's not good for them.

CG : Right. Well, if everybody wins the lottery at once, everybody has a replicator. Everybody's going to be pushing the button every day and trying all these different meals. Everybody is going to want to go all over the world, and once it's cleared all over the Solar System, and see all these different ruins that are everywhere. I mean there's going to be a lot that's going to be opened up. But first, we're going to have to go through the process of dealing with our past and getting over our past.

DW : Couldn't somebody have a replicator and build a very effective weapon with it and then kill a whole bunch of people?

CG : That's what buffer technology is for.

DW : What's buffer technology?

CG : They've got some of that on temporal drives to keep people from traveling back in time on certain craft that have temporal drives for engines, I guess you would say.

DW : So you can't just 3D print a nuke with a replicator or something like that.

CG : Right.

DW : OK. So there are restrictions. It's not you can make anything

CG : Right.

DW : What does the Alliance want to do as far as all this secrecy and all this occultism that we see in the world today, the weird stuff that is so upsetting and depressing? How do they want to handle that?

CG : They want to shine a light on it. They want to bring the truth, the information, to every human being at once on the planet. Not give certain people the truth, give everybody the truth. Give everybody access to this technology and information.

DW : So, no more cover-ups at all?

CG : No more cover-ups, no more partial disclosures. Just bring it all, bring it all to humanity.

DW : Yeah, that's really incredible. So that's all the time we have for this episode. We are going to have a lot more to talk about. Obviously, we're just getting started. But again, **Corey**, thank you for being here. This is really incredible information.

CG : Thank you.

DW : Bye.

Cosmic Disclosure: Life On The Research Vessel

Season 1, Episode 4

DW : Alright, welcome to the show. I am your host, **David Wilcock**, and we have a truly remarkable man here we are speaking to, **Corey Goode**, who has come forward as an insider, telling us about this remarkable new world of what has been called the Secret Space Program. **Corey**, the scope of this program might be hard for some people to accept. Granted we went to the moon in 1969. Some people would say, we allegedly went to the moon. But it certainly appears we did, at least do some real thing on the moon, and then we never went back. They put the flag in there. They ran a few missions and oh, we're done. We saw what we need to see. So, I think if you're going to think about people settling outside Earth at all, most people, if they could even imagine that, would say, well, it's probably not that much. What's the real scope of what we're dealing with? When the truth comes out, what are we going to learn?

CG: Well, it's going to be overwhelming. To learn that there is a vast infrastructure throughout the entire Solar System with everything from mining operations in the asteroid belt, and on moons and planets to procure raw materials to industrial complexes that produce technologies and colonies of human beings that work in those industrial complexes, and support this large industrial machine that is throughout our Solar System.

DW: We couldn't build a base inside a gas planet right? Because it gets too hot, and there's too much air pressure?

CG: Yeah, too much pressure.

DW: So if we want to look for these colonies, where would we be looking?

CG: Colonies are basically what we call the area to where families and people live.

DW: Okay

CG: There are also all types of different types of facilities. There are facilities in type inside hollowed-out asteroids that they've mined. There are facilities spread out across Mars, underneath of course, underneath the surface of Mars, and various moons of gas giants, and even our own moon.

DW: Could you try to give us an estimate of how many different facilities or different places that have been built there are, let's say, in our Solar System?

CG: In our Solar System, everything from small security outposts that man 18 to 40 people on Mars alone, to facilities that float around in different Lagrange points throughout the Solar System.

DW: Could you tell us what a Lagrange point is?

CG: They're areas between planets or bodies that have an uninterrupted gravitational, or an equal gravitational pull from all areas to where they can have a kind of geosynchronous, or stationary point to stay. And I really don't have a firm number. There are hundreds of facilities out there.

DW: What would be some of the larger of facilities in term of the staff, the amount of crew they would have?

CG: Well, we talk about colonies, we're talking about some of the larger ones that have upwards of a million people.

DW: Really?

CG: Yeah.

DW: How many do you think there would be of that kind of size of population?

CG: I don't think there's a lot of that have that large of populations, but quite a few that have into the hundreds of thousands.

DW: Does it get colder and harder to live in a place as you get farther away from the sun?

CG: That's where advanced technology comes in.

DW: Okay.

CG: We can produce the living conditions that are comfortable to us anywhere. And, even the Schumann resonance that occurs here on Earth. The Earth puts off a certain vibratory resonance that keeps plants and humans healthy, that Schumann Resonance is piped into spacecraft and facilities, colonies, to help keep the people healthy. And the barometric pressure, the gravity is controlled.

DW: I was just going to ask about the gravity. Obviously, the Earth has a certain mass, and the gravitational acceleration, 10 meters per second squared, is proportional to the Earth's mass. So, with the moons, it's believed by NASA – they talk about this – that you would bounce around.

So, how do they compensate for that if it's smaller?

CG: Well, they have gravity plating just like they do in the vessels, interlocking plating that are in the floors, that have electricity applied to it that creates an electro-gravitational field, that creates artificial gravity.

DW: What are the sizes of the plates? Do they vary?

CG: Well, the plates vary in sizes, because you have different size hallways. But there are plates about this (2-3 inches) thick that interlock like children's building-block toys that interlock or dovetail together.

DW: So, can you just give us a little more information about what would be the major categories? You said one type of a category of a place that would be built, an installation, would be a place where

people live. Is that strictly utilitarian like just a whole bunch of rooms where they bunk, or do they have a nice, big atrium with a waterfall? Do they have big common meeting areas or auditoriums?

CG: Usually, when I was on the research vessel, we didn't normally get to visit them. These were owned by the ICC (Interplanetary Corporate Conglomerate). They were corporate-owned colonies. If they did not have access to one of their own people to fix a critical piece of machinery or technology that was damaged, there was usually a specialist aboard our research vessel that had that expertise. And then, on those special occasions, we were allowed to go to the colonies under strict orders to not talk or interact with any of the people at the facilities or the colonies. We were under armed guard. We were not offered tours, not offered a meal. We were escorted straight to the location to where we were to do maintenance and then, escorted straight back to our vessel to leave.

DW: Could you come to Earth whenever you wanted while you were doing this work?

CG: No. When you were doing your "20 and away", you were totally cut-off from Earth, Earth news, everything Earth-related. We didn't get any news, any television, any information about what was going on Earth.

DW: Were you allowed to bring books and magazines with you to read?

CG: No. We didn't even have a photo of our family or anything like that. All you had is what was given to you when you reported.

DW: You talked before about these smart-glass pads. Did you get access to those when you were on this research vessel?

CG: When you were on duty, yes.

DW: Okay. Did they know what you did? Was there a surveillance record of whatever you tried to look up with them?

CG: I'm sure there was. On the research vessel, it was a lot more laid back than I hear things are on the military vessels. They always call the scientists "eggheads". They were perfectly fine. A lot of time, I got to spend a lot of time looking at the smart-glass pads. There was a lot of down time for me. Everybody had redundancy training. You didn't just have one job. I was trained in doing communications and a few other things. But a lot of the time, I would be in one of the labs, when some of the other work was done, and I would just have hours to spend, looking at the glass-pads.

DW: So, let's talk about recreation for a minute. People, are they more apt to hangout and talk to each other, or are they more apt to fuss around with the glass-pads and be alone and just try to read more interesting things.

CG: You would mainly only have access to the glass-pads when you were on duty.

DW: Oh, when you were on duty.

CG: Right, when you had off time, or you were in the galley or whatever you were going to communicate with other people and hear the scuttlebutt of what is going on.

DW: Did you have certain people that were, like, your close friends?

CG: I was mainly in tight with some of the "eggheads" or scientist because I spent a lot of time with them. And I was assigned to one bunk area that (to which) usually 18 to 24 people were assigned. And I get to know some people but people rotated in and out a lot.

DW: There was a lot of turnover?

CG: UmHm (yes)

DW: What was the kind of thing that you would talk about with these people? I mean, it's hard for most of us watching the show to imagine what it would be like to live in this world. Does it become ordinary after a while? Does it become boring after a while?

CG: Yeah, it was very boring. We would talk about work. We would talk about what was possibly going-on back on Earth sometimes, speculate about what other people were studying when we were assigned to study certain things, just your normal kind of chit-chat.

DW: How often did you visit various facilities when you were on this research vessel? You said you were on there for 6 years before.

CG: Like I said. It was a rare occasion. There were three different times that we visited actual colonies, and we visited the industrial complexes several times to do repairs.

DW: That would be more like factory-type facility

CG: Like a factory. And there was one occasion that we actually went to a mining operation that was in the asteroid belt.

DW: What would that look like?

CG: It was really just a three-man operation inside of an asteroid. They were operating mainly robotic and remote-controlled apparatuses.

DW: Only three staff we need to run it?

CG: Three people that would rotate.

DW: What was the size of the actual construction itself? How big was this area that was built?

CG: Well, this was an extremely large asteroid and it grew larger and larger as they were mining it.

DW: How could it grow larger? I don't understand.

CG: The inside space.

DW: The size of the hole.

CG: The size of the inside space of the hole was growing larger and larger and larger. You could see, (that) they started-off digging, and they were making more and more progress into this one large asteroid.

DW: So, if you only visited, you said, three colonies and then other industrial facilities but you were out there for six years, that doesn't sound like the main thing you were doing.

CG: No, it wasn't super exciting. A lot of what we did is we were studying, I guess you would call them exo-extremophiles. I guess modern biology and science are going to have to redefine what life is. Based on what I saw, the life I saw, being studied, there was plasma life, other types of energetic-type of life, that were basically like giant amoebas that were feeding off of the electromagnetic field of Jupiter. They tried to get specimens of those. They were so large, they would get small specimens that would basically die or somewhat putrefy. They weren't able to...

DW: What was it about them that made the space program decide they were actually alive?

CG: Well. They were not just alive, they showed signs of being sentient.

DW: Really?

CG: Yeah. They were self-aware. They had preservation-of-life characteristics. There were a lot of things they did, testing on them, that I guess wouldn't be extremely ethical to figure out...

DW: Well, I think your typical conventional view of biological life as it has to eat, it has to excrete, it has to have locomotion, it has to have respiration ...

CG: Neurology

DW: Right. You're going to have cells, you're going to have biological material ..

CG: Yeah. It's carbon-base life.

DW: So this life doesn't have cellular structure. It is not like the plasma is interconnected by cells.

CG: No. But they behaved like single-cell organisms in the way they reproduced.

DW: They actually reproduce?

CG: Yeah. What is it, Mitosis, where they split?

DW: Right.

CG: And there were also some ocean life under one of the moons of Jupiter under ice that was studied...

DW: Like Europa?

CG: Yeah, that were somewhat like whales or dolphins.

DW: Really?

CG: Yeah. So there's quite a bit out there that the scientific people are studying.

DW: How common would biological life be in our Solar System? Where do you find it?

CG: It's pretty much everywhere if you include on the microscopic level. It's pretty much everywhere. You can even find it free floating in space freeze-dried.

DW: Right. When we get beyond microbial life, do you actually find little guys that can walk around on these moons, like out around the moons of Jupiter? I know you said Europa, which is a watery moon, but what about a dry moon? Would there be a life that could live inside the surface of a dry moon?

CG: There is some life on Mars. There is some small animal life that mainly is burrowing, that digs. There's plant life on Mars that's very... what would you call something that grow in a desert... very robust. There was this one bush that was purple and red, that has huge thorns on it. And it was kind of squatty bush, and it had pointy leaves that were like thorns at the tip that were striped purple and red.

DW: How would you go out to see those bushes? Would you wear a suit of some kind?

CG: Yeah. There was a lightweight suite, not a heavy pressure suit.

DW: Did it have like a glass helmet kind of thing?

CG: Yeah. And a respirator.

DW: So, let's go back to the vessel for a minute. How many people did you bunk with on the vessel?

CG: It ebbed and flowed. There were up to 24 people that could stay in the area that I was assigned. It was anywhere from 18 and 24. It would change.

DW: So, you were contained, and you had to sleep all together in one room. Like the military style?

CG: Yeah. And we had bunks that were into the walls, and we would sit in the bunk. You would sit in your bunk, close your divider and you had a little organizer section that you could put whatever items you had.

DW: Did they keep you on a 24-hour cycle like on Earth? It's the same kind of measurement of time?

CG: Right

DW: Did they light the ship in any way that would indicate to your body that you're on a cycle?

CG: They tried to keep a circadian cycle going and pipe the Schumann resonance in, to keep everything, what the human body is used to for health reasons.

DW: Did some people work the night shift?

CG: Oh yeah. Constantly, people were on duty.

DW: How are you getting water? Obviously water on Earth, requires a hydrological cycle with clouds and rains. Water's so scarce on Earth now, with California's drought. How do you guys have it, in the middle of space?

CG: Water is not scarce in the Solar System. And when you're on board a vessel like that. Let's just put it this way, everything is recycled.

DW: So the whole ship is designed to recycled everything

CG: It's a very closed system, self-contained closed system. Yeah, everything is recycled.

DW: Do you end having to become vegetarian, or do people that like to eat meat still get a chance to eat something like meat? What are your meals?

CG: The quality of them has changed but, they had replicator that produced a certain range of meals. But they also had hydroponic areas where they grew some fresh foods.

DW: So, could you hit the button for "cheeseburger" on a replicator and get a cheeseburger

CG: No. It wasn't like that. No. You would hit a button and get a pot-roast or something like that.

DW: What were your favorite things the replicator made? Could you give us a list of what...

CG: I would get the pot-roast a lot and mashed potatoes

DW: Was it a fairly convincing pot roast? Did it actually taste like a pot roast?

CG: It tasted good, yeah.

DW: It came out at the right temperature? Did you then have to heat it once it was made?

CG: No, it came out at a hot temperature.

DW: Could you see the food being formed inside through glass, or was-it dark?

CG: It looks basically like a microware, the size. And you put in a plate, right on the area designed for the -plate, close the door, you push the button of what you want, and it makes a noise, and it appears. And you open it, you pull it out, and there's steaming food.

DW: What kind of noise was it?

CG: Similar to a microwave. When they would replicate something, would call it “printing something”.

DW: Really?

CG: Yeah

DW: Was there a name for the device? Did you call it something?

CG: A printer

DW: Really?

CG: Yeah

DW: How did you know what you were going to get? Was there like a digital display that you could choose from a menu that you’d scroll through or something?

CG: If you were to look at a microwave, you have a certain amount a button that you can push...

DW: So there was a pot-roast button?

CG: Yeah. There was a button for different meals.

DW: What about beverages? Could you get like a lemonade or a fruit punch?

CG: Yeah, but you didn’t get that through the replicator. There were dispenser for different beverages

DW: Did you grow the vegetables separately from the replicator? Like, you can’t print a salad.

CG: Well, there were some vegetables like potatoes and stuff like that, but some of the other greens vegetables they would grow.

DW: Okay. So, if you wanted to have a salad, is the vending of the salad near where the printer is? Do you have a refrigerator where the greens are kept?

CG: That’s when you’d go through the galley area, and have certain things that were prepared. You would have times, when things would malfunction, and you would have to have powered eggs and

ration foods and stuff like that. They had a galley area where they had people that would serve food slop.

DW: What were you wearing when you worked on this vessel?

CG: Jumpsuits.

DW: So, single piece?

CG: Yeah.

DW: What was the color?

CG: Well, different designations, different colors. Sometimes blue, sometimes white.. It just depended on what area you were working in.

DW: What would the white designate?

CG: White – It wasn't really a designation of a job. If I was working in the lab area with the "eggheads" or whatever, I would wear the white. If I was working in the communication area, I wouldn't wear the white lab jumpsuit.

DW: If you went to the front of the ship and then you walked at a steady pace to the back, how long would that take if you were to do the whole circuit?

CG: You couldn't walk straight. It was like a maze. Probably take you like 30, 45 minutes of walking all around if you stayed on one level.

DW: Is there a predominant look to the walls when you're inside? What's the predominant color of what you're seeing inside?

CG: Well, a lot of them were just metal. I was told that a lot of these first craft were built by people that built submarines. So it had a lot of the same type of feel and build. And in case there was ever a zero-G environment, there were handles along the wall that you would use to guide yourself.

DW: What was your typical ceiling height inside?

CG: Probably about eight feet.

DW: Did you have multiple decks, like, you could go from one floor to another?

CG: Yeah. There were multiple decks.

DW: Do you remember how many decks?

CG: I mainly stayed within four decks, but I believe there were at least nine decks.

DW: Did they have a specific classification, like a name for each deck?

CG: Yeah. They had designations for each area. There would be “level 1”. Then the dash (-), they would call it a tack, like “1 tack A” (1-A), “1 tack B” (1-B).

DW: Were any of these areas color-coded? Like, the walls looked a certain way to let you know you’re in a certain place?

CG: Well, something that was popular would be the colored lines on the floor that would lead you. But pretty much, you would know where you were going by the designation of the number on the door.

DW: You had said that the Alliance intends to handover this technology to humanity once we go through disclosure.

CG: Yeah. That’s the plan. After there’s a full disclosure, and after we go through the process of dealing with the full disclosure information and get past whatever trials that are needed and psychologically deal with the process, then all these technologies are going to be brought down to humanity to basically change our lives from us being debt-slaves working every day, working eight or nine hours a day to pay rent and watch TV for a few hours, go to sleep, and then repeat every day, to having a totally different type of life.

DW: Who decides who gets to go out into space? Is there going to be some restrictions on who’s allowed to go?

CG: I have no idea how that’s going to work out. I know that supposedly, it’s going to be a Star Trek-type civilization. I know eventually there’s going to be tourism to a lot of places in the Solar System. And there’s going to be a lot of new career-types for people.

DW: Do you think there are enough ships that a lot of people here could go pretty quickly if they wanted to, once this all opens up?

CG: I believe so. Yeah. I believe there's quite enough craft already created that we could use those for non-military purposes.

DW: Well, this has been really incredible. So again, I want to thank you for being here, and I want to thank you for watching. When you start to get this much specific details... You can tell pretty much when people are lying. They start to hesitate, and their body-language changes. And I've been talking to you for so long about this stuff, and every time I ask you these questions, I learn new things. And I'm convinced that what you are telling us, did happen to you. I think there is extensive evidence to prove that, based on how it correlates with everything else. So again, I consider you a hero for coming forward, and I really want to thank you for your service to humanity in doing this.

CG Thank you.

DW: Thanks

Cosmic Disclosure: We Are One

Season 1, Episode 5

Please note: This episode is free and available for viewing without a subscription at [Gaiam TV](#)

DW: Alright! Welcome to our show. I'm [David Wilcock](#) and I'm here with the insider's insider, **Corey Goode**. There's all different levels of classification in this stuff. As you go up the hierarchy, you learn that everybody thinks they know all there is to know, and it's been truly astonishing over the years to see how – I don't want to really put my foot in my mouth here – but how ignorant these guys are when they're being exposed to very cosmic phenomena like stargates and portals and anti-gravity and extraterrestrials that are clearly telepathic and have telekinesis in some cases, that they really don't get the "big picture", the spirituality component, the extraterrestrials visitations that made religions in the world. So, **Corey**, I've heard about these spheres coming into our Solar System, from several insiders. This is obviously a really grandiose, big deal. Nobody thought anything of this size would exist. What is your understanding of why these sphere beings have come to our Solar System now? What is it that they want? What are they after?

CG: They've been here for quite some time. They've been in a non-operational mode. They've been, I guess sort of, in observation mode, being that they came in apparently the late '80s, and throughout the '90s, and then started picking up their numbers around 2011/2012. There was obviously something coming. Something was starting to happen that made them move into an operational mode. It turns out that the Secret Space Programs and even some programs on Earth and the Black Ops programs had been studying a region of space that we were entering in the galaxy and some – what they had called “super waves” coming toward our solar system that were clouds of energetic particles. And, they knew that it was going to directly affect our solar system and our sun. And indeed, we have seen changes in the sun and changes in all the planets, occurring since at least that time period, if not, probably before. And this has been a slow change in the background-energy of our solar system. These are vibratory energy-waves that are ebbing and flowing into our solar system. These spheres, as it turns out, are equidistantly spread out throughout our Solar System, thousands of them, and they're acting in some sort of a “resonance buffer” that, as these energy-waves are hitting them, they're vibrating and causing the energy to spread out amongst them in a uniform way to where the energy is not harmful toward life on Earth or causes our sun to lash out and have destructive CMEs and that kind of thing.

DW: Did you ever get shown what the matrix of spheres actually looks like?

CG: It wasn't laid out for me, but when I'm on the sphere, and I'm being communicated-with through the sphere-wall, you can see the other spheres, off in the distance, equidistantly spread out, and there's thousands of them.

DW: Do they have a color, or colors?

CG: Well, they appear to be indigo/blue indigo, through the wall of the sphere I'm in. And outside the sphere, you can't see them. They are out of phase. We would probably pass right through them if we send a probe at them.

DW: One other thing that interests me is, if they're equidistantly spaced, you said that there's three sizes, though. There's the moon. There's Neptune, and Jupiter. Is it that the bigger ones are closer to the sun, to absorb more energy, or is there a reason why there's different sizes, if they're all in the same spacing of each other?

CG: I don't know why the size difference is. I know that the larger ones are out close to the gas giants. The largest number of them are the moon-sized ones. Those are the ones that are spread out

equidistantly. There are a large number of Neptune, and Jupiter-sized ones that seem to be spaced further out towards the gas giants and out further towards the Oort Cloud. And that could be - this is me speculating – larger, medium, and then getting smaller as you go in. It could be some sort of shielding that's done larger, medium and smaller that has some sort of resonance purpose. But that's me speculating.

DW: Was there any evidence that these sphere-beings had ever even tried to contact our government at any time in our recent history before when they just showed up recently?

CG: Not directly that I know of. I know that they had told me that three other times in history, they had communicated with humans and given a similar message, and given more detailed information to certain people and that they had turned it into religions and cults and totally distorted the information. But I do not know of any time when they have been directly in contact with the government. During the '50s, we were being contacted by a whole array of beings. Some of them were coming to us wanting us to get rid of our nuclear weapons, and delivering a similar "hippie message" that the military people didn't like. They didn't want to get rid of nuclear weapons. They wanted to find, to obtain more technologies that they could turn into weapons.

DW: Could you just double-click on that and get a little more into that message? Who were those people that showed up the 1950 and said this?

CG: Well, they was one group that was reported that were described as appearing similar to "The Greys", and they called them "The Blues", but they were very tall. That's the description that I had of them, and they were described as being very "love and hippie"-like. And they tried to warn us about decisions we were making, groups we were getting involved with, and the dangers of nuclear energy and nuclear weapons and the route we were taking. And we, unceremoniously, sent them on their way.

DW: Is there any similarity between "The Blues" and the "Blue Avians" in terms of their message?

CG: It seems that there's a very close tie-in in their message and their general way of thinking. I wouldn't go as far to speculate that they are one of the two sphere-beings that haven't presented themselves. I have no idea who those other two are, but it wouldn't surprise me if they turned out to be...

DW: What did they claim we would have gained if we gave-up nuclear weapons? Did they want some kind of disclosure?

CG: Yes, they wanted full disclosure. They were prepared to provide peaceful technologies in exchange for us giving-up our militaristic and the way of life that we had at the time, the war. We had just gotten over World War II and we were pushing deeper and deeper into the Cold War. And they saw that as something they wanted to “nip in the bud” and the people that were in control of Earth didn’t want to have anything to do with that path. They wanted to have more power and more weapons, more technology. And there were other beings out there that were happy to give them that.

DW: So, these Blue Avians, they have an agenda that involves what exactly? Why do you think they’re here?

CG: They have given a message that they are not here to be our saviors. They are not here to come down and arrest or remove all the bad guys. They had a message for us, and the message is basically the same as the tenets of a lot of the basic religions on the planet, basically similar to the golden rules. They stated that we should focus, because of the vibratory changes that our solar system is going through, we should focus on raising our vibration and raising our consciousness.

DW: So you think there’s some reason why they chose the avian form, like maybe the feathers and angels, that kind of connection?

CG: I have no idea. I have no idea why they chose the form they did.

DW: Did they tell you that they don’t need to be in that form?

CG: Yes. One of the things they stated when they were answering questions, was that they don’t need any type of conveyance. They don’t need spaceships, they don’t need technology. They’re a consciousness, higher vibratory, higher density type of being. They can change their location by consciousness, just by thinking it so.

DW: You said that when you had the delegation, the first meeting, where you spoke on their behalf, that they just appeared in the room behind you?

CG: Correct.

DW: Is that a normal thing that intelligent civilizations do?

CG: No, normally there’s some sort of technology involved, even if they’re using teleportation.

DW: So, obviously we're in a tangled area because they've chosen you as a messenger and clearly you're not an average guy. There's nobody else I know of who's been willing to come forward who's been taken up into space. You've had this happen your whole life. Did they say anything about why you had such an unusual life? Do you have a connection to them that goes from before?

CG: The avian that I was talking to, Raw-Tear-Eir, he informed me that I came from their soul-group and that I was here for a reason, that I had chosen to be here for a reason.

DW: Did he explain what he meant by soul group?

CG: That there were wanderers and starseeds that were here on the earth that are there for a chosen reason, a chosen purpose and there are a whole lot of different definitions of starseeds and wanderers out there. And in my case, the definition just seemed to be, that at one time, I existed in their plane among them and that unbeknownst to me now, I chose to come here during this lifetime for this purpose. And among the conversations or communications, they said that I needed to make sure that I didn't present myself as any type of guru or to let my ego get overdeveloped and to make it all about the message, and make sure that none of this develop into a religion. We need to focus on the message and focus on expanding our consciousness and raising our vibrations.

DW: Some people watching this might think that you're part of this extraterrestrial elite, that some people on Earth are going to have these higher connections and have these group souls, whereas everybody else is just sort of like another useful eater or sheep.

CG: The number of people that are here right now, that are here for a purpose is an astounding number. I heard that back in the '80s, it was over 60 million or even more. The number of people that are here that are starseeds, that are wanderers that have not awakened to that, is a huge number. I'm not unique.

DW: Do other people who are not starseeds or wanderers still have some soul themselves?

CG: Yeah, everybody has a soul.

DW: Well, most people don't know that.

CG: A lot of people are having visitations or contacts by these orbbed beings, this is a process of the awakening that's occurring.

DW: What are some of the other ways these beings might be using to awaken people?

CG: Dreams.

DW: What would a dream be that would be, like, an example?

CG: Well, there are a lot of people that are reporting having dreams contact with some of these beings in dreams. They're having dreams of being in classrooms, just dreams of being in classrooms where they may not consciously remember what they've being taught. But they are having memories of being in classrooms with groups of other people. A lot of it's happening through dreams.

DW: How important is the soul in their message?

CG: Well, the soul and the higher self-connection, that's most of who we really are. The conscious waking self, the part of us right now having a conversation is a VERY small part of who we actually are. We are a multi-dimensional being. There is so much going on, on many levels. This is my personal outlook on it from my communications with several beings, is that we have our conscious self, we have our subconscious self, and our higher-self, and then the higher-self goes higher and higher until self drops off the equation. Then you just have the higher, until it returns back to source, and source is where we all came from and fragmented from, and are all still connected to in some way. That's how we are all still ONE.

DW: So, they're here to teach us this "law of one" principle?

CG: I guess you could say that.

DW: How about people seeing 11:11? Could that be – or whatever synchronicity?

CG: Yeah. Definitely. Those synchronicities – I've been seeing those, synchronicities like that for over 30 years. I look up at the clock and see 11:11, see 11:33, 3:33. A lot of that, those synchronizations could be telling you that you're on the right path or that you are on the awakening path. And if you're noticing that, I think that's usually a good sign.

DW: So you said that they explained to you personally that we are all part of some sort of universal mind?

CG: Correct.

DW: Could you get a little bit more into detail? Did they ever give you a visual representation of that? Did they give you thoughts or feelings? How was that information conveyed, and what is the essence of this identity when you say we all come from one source?

CG: Well, they've told me we are all one. We all come from Source.

DW: Did they say what that is?

CG: They did not. But ever since I was a kid, I would say strange things. I would say unusual things for a 5 or 6 year old. I would tell my mom that, did you know I used to be you? You used to be me? I used to be grandpa, and he used to be me? And she would look at me and she'd say, well, that's physically impossible. I would say, no, we're all the same. We've all been each other. And she'd say, well, how can we all be each other at the same time? And I would tell her, time doesn't matter. Only the experience matters. And it would concern her. And my grandfather and I would have conversations about it. He would humor me and we would have long conversations about it, but they were unusual conversations for a kid of my age to have. But there are a lot of children that have that kind of insight that parents quash when they should be definitely listening to it more and encouraging it.

DW: It seems that in a lot of these other attempts that they made to help us, which you say turned into religions or cults, they keep stressing meditation. Is there a relationship? Did they say anything about meditation and this "universal mind"?

CG: Yes, prayer and meditation are what help you raise your vibration and help you raise your consciousness. So you can do it through prayer or through meditation, and meditation is very important. That's something you should probably be doing at least an hour a day.

DW: Did they say that specifically?

CG: No, that's..

DW: That's just your understanding?

CG: Yeah, that's my personal opinion. When I've focused and put an hour a day in of meditation, I've notice a lot more focus and ability to be able to walk this difficult path of being more loving and forgiving and not being reactionary to everything. When we're caught up in this world, this 9 to 5 world where we become very reactionary and triggered by things. And if we put more time into raising

our consciousness through prayer and meditation, that helps give us the tools to become more focused on being on service-to-others and loving and forgiving.

DW: Does that meditative practice help co-create the reality that we live in?

CG: Yes, and I think that's been proven many times over in experiments that have been.. experiments that are repeatable. One of the ones that you've mentioned is the experiment where 7,000 to 10,000 people meditated and brought down the crime level.

DW: Yes, by 72% worldwide.

CG: By 72%. And people that meditate or think loving thoughts on a petri dish with a certain type of yeast or something in it and another one where people have hateful thoughts, and then over a certain amount of days, the difference in the two. It's repeatable. It's science. You can't refute that something is happening. Consciousness is affecting physical reality.

DW: Well. That also is mass hysteria, right? If you get a large group of people and a few people start panicking, the panic could spread.

CG: Right. Humanity has a very wide spectrum of emotions, and that is a blessing and a curse. Once we learn to control and focus those emotions and also focus and get more control over our consciousness, we're going to be able to have more access to our co-creative mass-consciousness that we all share and we'll be able to create whatever reality we like. And I know people have heard the concept that everything is vibration – the light, our thoughts, all the physical items around behind us. They may be solid to our perception, but they are all states of vibration. And our consciousness can have an effect on the reality, on actual physical materials. They can have effect on energy, on other people's thoughts and emotions.

DW: We see these comments showing up on the internet where people are saying, **Corey Goode** is lulling us into a false sense of security. This is a Cabal Psy-Op where they're telling us through this messenger they've chosen who's had all these... they're accusing you of being in secret cults and things. He's just trying to give us a palliative. He's just trying to give us a little lollipop, so telling us we can hum it away. How do you answer these critics who are saying the you're a "pied piper" for the military industrial complex leading us into a false sense of security so they can just swoop right in and take us over?

CG: I do not know many negative forces that are putting out this type of message of love and forgiveness and raising your vibration and becoming more aware of the negative forces to be able to get out from under them. The negative forces don't want you to shine a light on them and become aware of them. They want to hide in obscurity, and I'm definitely not making them happy by shining lights on some of their activities.

DW: People think that they need to tell us the truth so they have to hide out in the open. It's part of their magic.

CG: It is.

DW: Okay.

CG: That's how they use our co-creative consciousness against us right now and they've hidden the science. In science, they realized that if you observe a certain scientific experiment, observing it will change the outcome. And there's been a lot of studies into that, and they've hidden that and they don't talk about it. They don't want us to know about our co-creative conscious abilities because they use those as a tool against us. So, if by us liberating our consciousness, we are taking away a tool that negative forces use to enslave us. We have the tool to liberate ourselves.

DW: Most people say, though, that if the media always seems to find the most negative thing that anybody has done on Earth and they make a big deal out of it. It's always fear. If it bleeds, it leads. But then the skeptic would say - they're just saying that because humans are naturally reactive. We naturally want to look for the problem and then try to fix it. Is that the only reason why they're doing that? Why do you think the media focuses on fear so much? Why would this be beneficial to anybody?

CG: Well, it's all about planting a seed in our mass consciousness. And then later on, after they've planted that seed in our consciousness, they do something like a false-flag or put out another movie or do something else that causes us, with our broad spectrum of emotions and our co-creative consciousness, to activate it and to cause it to occur. That's the secret behind their so-called "Black Magic". It is not really their power. It is them using, co-opting our power of co-creative consciousness.

DW: If these Blue Avians weren't coming here and giving this message through a variety of forms, what's the end game for that mass manipulation that you're talking about? Like, what would happen if we weren't getting this help?

CG: It would be a constant status quo.

DW: Are they trying to do a police state or martial law, something like that?

CG: There's always a speculation of a September or an October surprise always on the horizon. There's always a new thing in the "fear-porn" machine. Just over the horizon, there's a big crash. There's something big about to happen...

DW: That's true.

CG: That they keep at the back of our consciousness constantly. It just never ends.

DW: So you're saying that if they can get people even through alternative media and apparently credible alternative media journalists, if they can get people focusing on the negative, you're saying that we have this creative power and that meditation effect where it decreases crime and terrorism would be a positive effect of it. But you're saying that also if we focus on fear, just the power of our mind alone can actually make more negative things happen on Earth?

CG: Yes, this was done by design.

DW: Do you think that Hollywood movies have conditioned so many of the people that learn about the Cabal that they feel like the only solution to something like this Cabal would be a military-type attack, like some sort of big action-movie battle scene?

CG: Yes, and what the Blue Avian message is trying to teach us is that you can't get a positive from negative. You're not going to bomb your way out of this. You're not going to be able to get your way out of this by having riots. The way out of this is through our co-creative conscious abilities and waking up. And we're the billion ants, and they're the very few beetles that are trying to keep us down. Once we wake up and turn our attention to them, they're "done for". As long as they can keep us scurrying about in our little anthills and not focused on them, they've got us focused away from them.

DW: Well, I think that a lot of people think third-density in the terms that they've also used with you – the Blue Avians have used with you, the third density is all there is. So if you have a third-density problem, you've got to have a third-density solution.

CG: And also we hear of these other beings. Usually you can tell a lot by someone if they accuse you of something, that's usually what they would do if there were in your same situation. So you can learn a

lot about a person when they accuse you of something. Well, (the) same goes for these other higher density beings. We're kind of imprinting on them - agendas. People get upset when I say - in our third-density way of thinking; we can't understand the way they think and the way they operate. And some people get very upset, like I'm "putting down" humanity, humanity's intellect, and they just don't get it, that we're just not at the point to where we can fully understand these higher realms, and the way they operate.

DW: Most people who suffer paranoid schizophrenia, there's certain characteristics that would include a Christ complex, where they feel that they are a messianic figure and that they have all the answers for humanity.

CG: I've been getting a lot of emails from them. (laughs)

DW: It seems as if the fact that schizophrenia does cause this to happen, people to feel this way, has led people to think that any notion of any density, like when you say "higher density", that that's completely different - that you're crazy, that you are a schizophrenic, that this guy is making this all up. Boy, is he taking **David** for a ride. How does a person experience a higher density? How do they know they're not crazy, that they're not schizophrenic, that there's something happening here that's real for them? Or, how was it for you? How did you become convinced that there's something more to our reality?

CG: Well, there's something called, "testing the spirits" as you may call it. In the beginning, they came to me in dreams, as they first do, so not to freak you out. But the experiences, when they first started physically appearing with me, I wanted to make sure that it was a physical experience. And when I found out it was a shared experience with other people and spoke with, who we call Gonzales, who's been in contact with them as much as I have, and they would talk to me about him, and talk to him about me. It was definitely a real experience when they're talking with members of this Secret Space Program Alliance, and they come and pick me up in a physical craft and take me up to a physical location and I'm having conversations with real physical people. So, it's not...I don't channel. Not that there's anything wrong with channeling, but I'm not getting this information from an unseen unheard force that could be some of... the Security Intelligence Agencies have this, which I've seen used, "Mind of God" technology, where they can send in voices in people's heads, download information into people's heads. Even some people that are channeling are actually getting contact from this "Voice of God" technology. So, I'm not saying that all people that channel, but some. But this is something that

you do have to be careful and discerning about, and I always encourage people that are listening to the information that I give to use their own discernment. It's either going to resonate with them or it's not. Either spiritually it's going to resonate, or it's not going to feel right.

DW: If somebody wants to make today a special day in their life, a day that will always be remembered from now on, how could they do to make today that special day that they'll always remember?

CG: Make a little extra time today. Sit, find a quiet area. And even if you don't know how to meditate, meditating is just, almost a form of even daydreaming. Sit there and focus on your mind and focus your mind as long as you can at first on positive, loving thoughts, and on how you can become more positive and more loving to the people around you. And how you can become more service-to-others and more forgiving to yourself and others.

DW: And what will that do?

CG: It will change the world one person at a time, being yourself.

DW: Well, that's great. Well, it's a real honor to be able to get this message out through you. I've been saying the same thing for a long time and it's nice to hear it from somebody else. So, I hope you've been enjoying this. I'm [David Wilcock](#) and I'm here with **Corey Goode** and we have barely even scratched the surface of all the detail of what you know the space programs. We wanted to get into the message early, sort of like dessert first. So if you're interested in a lot more facts, there's a lot more coming up in future episodes, so please stay with us. Thank you.

Cosmic Disclosure: Sleeping Giants

Season 1, Episode 6

DW: Alright!, Welcome to our show. I'm [David Wilcock](#) and I'm here with **Corey Goode**. And we're going to get back into the "Alice in Wonderland" weird, cool, amazing space program stuff you've never heard before. And that's why we're doing this show, because **Corey**, you've come out with so much information that validated what I've heard from others, that nobody else has got. And that's just your background. So, time, for us in this reality, we think of time as being normally pretty stable and

unchanging. What do you feel is the contribution of relativity theory and Einstein to that? Did you ever come across any discussion of relativity in the Program?

CG: Well. Yeah. They discussed that there was a part of his equation that was wrong, that...

DW: Oh! They did?

CG: Yeah. That there was part of the equation that you just needed to flip. And that later on some of his work was more right on, but it was suppressed.

DW: Well, Einstein would say that as you go towards the speed of light, the time actually speeds up. So you could be in your ship for like a week, and yet everybody else around you might have gone ahead 1000 yrs.

CG: At his knowledge of our current technology level, that might make sense to them, yeah. When I was in the program, the Secret Space Program, when I would have time to sit and look at the smart-glass pad, there was lots of information that I looked at. And one of them was that there were beings that they found underneath the surface of Earth, underneath...usually underneath mountains, burial mountains...

DW: Really?

CG: Indian burial mounds that were not dead but weren't quite alive. They called them "stasis beings". And it turned out that had used a technology that had been there long prior, from this group they called the "ancient builder race". And this technology allowed them to lay down in either a sarcophagus or on top of a stone-looking bed or altar and it would create a time-bubble, or well, around them to where time on the inside would occur at a slower rate than time on the outside.

So, it didn't put the beings in stasis that a lot of us would think of, as in being frozen. But it just changed the way they experienced time. And they apparently took some sort of...something that caused them to go to sleep. And they would go to...their experience, they would probably go to sleep for maybe 20 minutes, and 30,000 years or so would pass by.

DW: So you're saying that a 20-minute rest could skip ahead by 30,000 years?

CG: By—in their perspective, that's what it would be taking, like, a 20-minute nap.

DW: I guess most people would find that really hard to believe. But if you have Einstein relativity in your background, right, let's that maybe in the local area you think they could be speeding it up to light-speed somehow, like the vibration, so that you're just skipping ahead through so much time?

CG: This ancient builder technology is so far beyond even what most of these fourth/fifth density ETs that we're dealing with in some of these meeting that we're having, these conference meetings. They're so far beyond them technologically, that some [or] these beings want to get their hands on this technology. It is multi-dimensional technology, some of this technology looks like a slab, but the technology is operating on other dimensions. So it took us quite some time to figure out that some of the stuff was actually technology. It was basically magic to us, even up in the 20th century.

DW: Did anybody ever figure out how to use the technology?

CG: Definitely. Yeah. It has been figured out. And what was very interesting is that in these smart-glass pads, there was this one location that, back in the 1800s even, people were going from certain, I guess some people would call the, Illuminati groups or whatever, elite groups – were going to visit this one area that had – it was like kind of a grotto, underground cave. And it went up about 90 feet. And it was covered... They had coated it in some sort of pitch-black material. And there was an ancient script language that was around on the inside that they had mostly deciphered, and were hand prints, and there were three sarcophagi in kind of a y-shaped on the floor. And in the middle was kind of like a box, but with almost like 4x4 in each side suspending a top and a bottom. And in the middle was, like a blue glowing crystal matrix with a spider web connecting it to the four corners, suspending it. And this is what was creating the temporal well, or the temporal bubble.

DW: It's a glowing crystal?

CG: UmMmm

DW: Did it look like a quartz crystal? Did it have a shape? Did it have facets?

CG: Yes, it had facets. It looked like a quartz crystal

DW: Really? And you said like a spider webs, like little fiber optic cable kind of thing?

CG: Could have been fiber optic, but it look like spider web connected to the top and bottom of it.

DW: And you said there's four posts that are holding the spider web, to then, the crystal?

CG: Correct. And it was suspended down from there.

DW: And they saw this in the 1800s?

CG: Yes.

DW: Back when there's no electric light.

CG: Yeah. Back when they had torches.

DW: That must have been mind-blowing for them at that time.

CG: I would imagine

DW: What's in the sarcophagus?

CG: Wee, they couldn't see it, so they had to build scaffolding up to climb up and look down in. And to look down in, they saw these very tall beings, or very large giant humans with reddish beards. And their skin, because of the pale white, they look kind of gaunt. But that looked – I think it was because of the lighting.

DW: The blue light?

CG: The blue light.

DW: Was there anything else in the sarcophagus besides the beings?

CG: Outside of the sarcophagus, there were jars and stuff that we presume had food or something to drink, or something in them. Their shoulders were like this, like they were kind of squished into the sarcophagus. So I did not see anything in these sarcophagi.

DW: Do you think they kind of squeezed themselves? Because maybe it wasn't originally built for them.

CG: Right. Right. It was – It did not look like it was originally built for them. But what was interesting was there was a long hallway underground that went to this place that had a lot of ancient Native American art and...

DW: Like petroglyphs?

CG: Petroglyphs. And right at the entrance was kind of a large stone that came out, rounded out before you went this way to go into the grotto. And people had been basically tagging it, writing their name on it. And one of the names, that was on it was Abraham Lincoln. And I think Abraham Lincoln made remarks about giants.

DW: He did a speech at the Niagara Falls and said that giants had stood right before us and had walked on this very land. And he was dead serious about it.

“The eyes of that extinct species of giant, whose bones fill the mounds of America, have gazed on Niagara as our eyes do now.” - Abraham Lincoln.

CG: Yeah. He knew for a fact. But the information on this glass, this smart-glass pad, stated that they had finally, to preserve the integrity of the spot, they had to close it down. Because of all the people going through, they were starting to destroy the petroglyphs and... they had to stop all of the elite group that were going there for kind of pilgrimage to see these giants that they had built up in the myth as a part of their religion, as being their gods or something.

DW: Who else besides Lincoln do you think was on the wall?

CG: That's the only name I recognized.

DW: But they would be government-type people and high-level ranking Masons, that kind of people?

CG: Yeah. They would have to be very elite, well-placed people.

DW: The petroglyphs imply that Native Americans had also found this.

CG: Yes, and the burial mounds at the top, it signified that it was a very holy or special place to the Native American.

DW: Can you tell us where this was?

CG: It talked about, it was down at the end of a river. And I'm trying to remember if it was Ohio or Georgia. I think it was Ohio.

DW: Okay. So, these beings kind of scrunched into the coffin, and they're red-headed, white-skinned giants. What do you know about those red-headed, white-skinned giants? Did they only appeared in

America, and how recently were they around? What do you know about them from your own experience?

CG: Well, from what I read, they've found these stasis beings all over the place.

DW: All over the planet?

CG: All over, yes, all over the planet. A lot – in some of the areas, some of the beings they found in stasis were of a different ethnic group that had, I guess, found these technologies and learned to use them. But these tall, red-headed, red beard groups were in Europe and South and North America. And apparently, at one time, before the last Ice Age apparently, they had a very large area that they ruled.

DW: Were they extraterrestrials that had come here?

CG: I did not see anything that indicated that they were extraterrestrials, but some groups are very convinced that they are extraterrestrials.

DW: What was their level of tech, the giants, what was their level of technology on Earth?

CG: Some of them seemed to have very advanced metallurgy technology. But there were no real sign of high technology as we would consider technology. But then again, a lot of the stuff that we found that we thought were stones ended up being technology. So. But we didn't see anything that we would recognize as high technology back then that was in the database that I had access to.

DW: Where were they going to get this technology, these stone slabs and stone sarcophagi? How did they procure them?

CG: This technology is littered beneath the earth's surface. And there were a lot of these locations where they found these stasis beings and the technology had failed, and the beings were deceased.

DW: Really? So you say it was littered all over the place, inside the Earth. I guess, if our civilization could be well-preserved, right now you'd probably find lots and lots of smartphones. So you think this is something that everybody used all the time?

CG: Well, yeah. And it was obviously built to last. It was made out of what looked like diorite stone. And it did not – I mean it's lasted for, you know, millions of years, it's very old.

DW: How Many sites are you aware of where stasis beings are still in stasis successfully around the world?

CG: There are – Well, there are dozens in the US and across Europe, going into Asia.

DW: Dozens.

CG: Many dozens. There were some Asian stasis beings..

DW: Really?

CG: ..and there were some ancient, like, eastern Indian-looking.

DW: And these folks would look more like people we'd see now on Earth?

CG: Right.

DW: Okay.

CG: Yeah. From obviously later era that learned how to use this technology.

DW: But you're not going to find the technology on the surface. You're going to have to go into these underground cities?

CG: Right.

DW: Have our people figured out how to switch it on? Do they know to turn on the stone?

CG: Yes. It's operated on a consciousness level, interactive level. And they finally did – once they realized that the stuff was technology, they did learn – start to learn how to turn it on and figure out what it was.

DW: Do you know if it does anything else besides create a time bubble? Does it have other purposes?

CG: I don't know. And the information that I had at that time, It didn't ... They didn't speculate as to why these being were putting themselves into stasis.

DW: Has there ever been any ancient builder race people themselves that they thought were still in stasis after all that time?

CG: No.

DW: Hmm.

CG: They have no idea what happened to them. I've heard myths, speculations, that people have said that they went to a higher density, some that they were killed off, some that they left and will come back some day. There are all kind of, in the programs, there are all kinds of myths about it. But when it comes down to the hard, cold facts, nobody knows.

DW: You mentioned before that when we see one of these underground cities that the ancient builders race created that there are pyramids.

CG: The images I saw – I didn't see this in person. The images I saw, they had some that were in pyramids, flatter pyramids --

DW: Really?

CG: It looked almost as if it was a crystal pyramid.

DW: You could see right through the pyramid?

CG: Yes. And if some people saw it, they would probably think it was made of crystal. But it's made of a high-tech aluminum alloy that's transparent.

DW: How big would those pyramids be?

CG: They were quite a bit smaller than the pyramids of Egypt. And I don't know what purpose they served.

DW: But you said, the stone pyramids actually are made of blocks of stone.

CG: Right.

DW: Whereas I guess with these pyramids, they're all one piece?

CG: Yes. They were all one sheet piece, and there were no seams.

DW: Did it have sort of a mother-of-pearl rainbow shimmer on it, or was it really just clear and sharp?

CG: No. It looks just like crystal.

DW: Wow.

CG: And there are other structures that were I guess rectangular and some of them had sort of (an) A-frame on the top. And then some sort of the square ones, had sort of pyramidal tops to them.

DW: You said that most of the moons – you've said this before – most of the moons in our Solar System, where they could build anything, have it built, right?

CG: Right. There's remnants. And a lot of it's been, like I said, later ET groups have tried to – in the distant past, had tried to wipe away remnants of who they were. And that's how we don't have any idea who they were, because areas to where there was obviously some sort of writing or petroglyphs or something had been wiped clean.

DW: But the technology of these time-bubble-creating slabs, that is consistent not just under the earth but in these other sites that you find in these moons as well?

CG: I have not heard anything about that type of technology found anywhere other than associated with the stasis beings.

DW: Do these ancient-builder-race sites, in the moons, in our Solar System, have these similar transparent aluminum pyramids and that kind of stuff in them?

CG: Other – Yeah, structures made of the same materials.

DW: But, are they pyramids, as well?

CG: There are. But they're mostly – there's a lot of them that are towers that are – there are a lot of them that are like towers, that are and stuff like that are twisted and over, like, there's been some sort of concussion wave of something that – something happened.

DW: In a variety of these locations.

CG: Yeah. They're not really intact like they were below the ground.

DW: Like some sort of massive military strike took place.

CG: Or natural cataclysm, something.

DW: Okay. Wouldn't there be a temptation for people to want to get to these beings and pull them out of stasis?

CG: Well, the groups that were in charge saw them as some sort of spiritual gods or something like that. So they left them alone. But, when it comes down to it, that's all the knowledge I have about them, is that they were in stasis and nobody knows why, and that some of them have perished, and they're using the ancient-builder technology.

DW: I think you had said to me something about the time-bubble and what happens if you try to go into the time-bubble.

CG: Yes, there was some technology that had time-bubbles around it. There had been people that had tried to enter in and they froze in time. And there were people from other time-frames....that I read about in the smart-glass pad that were also trapped in these time wells. So they're not something you want to go charging into.

DW: What would be the incentive, you think, for these to want to wake up now? What is it that they're expecting is going to happen that's so cool in our time?

CG: Well. This huge vibratory change in our Solar System. This change – supposedly we're changing from – graduating from one density to another. We're in transition. So if this is true and these beings are awakening, and they set their selves to wake up during this time period, I could only speculate that they wanted to be part of that.

DW: How do you explain a machine that has no moving parts? It doesn't – you said it just look like diorite which is black granite.

CG: We couldn't explain it for quite some time. It was, basically, magic, but it has parts that were working on a multi-dimensional level. You know, in our dimension, it just looks like a piece of stone. But it has parts that are drawing energy or maybe even moving or working in other dimensions that we're not fully aware of.

DW: You said that there have not been any of these technologies found anywhere else except inside the earth.

CG: I was talking about the stasis gravity well. There have been other tech – there's been technologies found all over the Solar System.

DW: Are there technologies that could create these time-bubbles that have been found in other places?

CG: The only thing I've read...mentioned about that was found in caves and underground on the earth.

DW: How many different types of beings have been found in stasis? Would that include extraterrestrials that just showed up here and not just people from Earth and giants?

CG: I have just heard about the ones that I've mentioned. I've just read about the ones that I've mentioned.

DW: If this technology is so peculiar, is it something that a lot of other beings have developed? Or is it sort of unusual, even for the average intelligent civilization that's been dealing with our Space Program?

CG: I don't know what other civilizations have developed. I know that they're very interested in this technology. And for a while, they were doing a lot of trade with us...before we knew what it was, to get it from us.

DW: Really?

CG: We've been doing a lot of expeditions to get this. And finally we were like, why do they want these stones. Why do they want these relics so much? And then, after we became sophisticated enough in our way of thinking, and realized that it was a technology, we stopped trading it.

DW: So you say that there's huge amount of these cities that are unexplored. So there's going to still be a lot of more of these left behind when we go in there.

CG: True.

DW: What do you think we could do with a time-changing technology like that? What's the ultimate – if humanity comes into possession of these? What do you think we could end up doing with a technology like that that could be beneficial?

CG: I wouldn't want to speculate. I really don't know.

DW: Are there other ways that we have to manipulate time?

CG: Yeah. We have certain types of spacecraft that use temporal drives in them that they've put buffers on to make sure that people don't travel back and forth in time.

DW: What is a temporal drive?

CG: It is a way of traveling great distances in space/time, without having to deal with traveling through the natural portal system that a lot of other civilizations use, the galactic web.

DW: So you sent me a couple of links to some videos that you claim may actually be stasis beings?

CG: Correct. Yes. These were images – there were two different videos. One was of a stasis being in a chamber that had apparently failed and the stasis being had perished. And the other was of a stasis being still in stasis that was in the process of being revived, I am told.

DW: What are we going to see here, with this first stasis being?

CG: The first one, we're going to see is the one of the failed stasis chamber, and the one where the stasis being had perished.

DW: So, let's check that out now. So, what's up with the gold fish on his chest that's got the Sumerian cuneiform writing on it? Is there a connection to Sumerian somehow?

CG: Yeah, there seems to be going back into the distant past, a steady progression from a root tongue or a root language that was kind of a proto-ancient Sumerian language that has popped in a very few places in modern archeology.

DW: Is it normal for these stasis beings to be buried with gold iconography like this, gold artifacts?

CG: Not all of them, no.

DW: Alright. Now, let's check out the second video.

In this one, it's different because there's no coins over his eyes. He's got a really long beard. So, what are people about to see in this video? Do you think this guy actually is in stasis, or do you think this is another failed one?

CG: This appears, if it is indeed genuine that they're in the process of coming out of stasis, as they're being revived.

DW: So one of the things that struck me about this was the Egyptian, clearly Egyptian female head on that golden plate that's in there. And then, this very strange little statue, of this guy that has two snakes coming up from the sides, almost like something out of Hinduism. So it's like we're seeing different religions being blended in. When you look at the newspaper with the Arabic on it, there's some Sumerian cuneiform on the gold text to that. So, we've got Hindu, Egyptian, and Sumerian all represented in this one guy.

CG: It's not uncommon. And some of the – there have been some cave-type structures that were once inhabited by these tall red-head, red-bearded beings that are very tall that especially inhabited North America a long time ago. And there have been artifacts of crossover civilizations been found.

DW: Wow. That's very significant.

CG: UmHmm (yes)

DW: Well, these videos were quite fascinating and I'm glad that you found them and sent them to me. They had all Russian titles on them, but they're obviously not from Russia. It's Middle Eastern, most likely. Turkey and somewhere, maybe Egypt.

CG: Right. Like I said, these have been found across the world.

DW: Well, this has been a very fascinating subject. I don't think I would want to put myself in stasis, but I understand why, if this big energetic change is coming our way is so amazing to these people, that they would want to do something like that and be ready for the big show. So that's all the time we have for this episode of [Cosmic Disclosure](#) I'm your host, [David Wilcock](#). And we're here because you need to know the truth. Thank you for watching.

[Cosmic Disclosure: Mars Colony Inspection](#)

Season 1, Episode 7

DW: Welcome to [Cosmic Disclosure](#). I am your host [David Wilcock](#) and I'm here with **Corey Goode** the insider's insider, a man whose experiences have truly revolutionized what we know about the UFO

phenomenon as a whole, and particularly what we know about a group within the military industrial complex that has colonized space and extensively built out a vast amount of habitation in our solar system for the purposes of industrial growth and trade with a wide variety of extraterrestrial civilizations. So, **Corey**, welcome to the show.

CG: Thank you.

DW: We've been talking in previous episodes about this very bizarre chain of events that starts to happen when you get pulled back into the space program after years of absence. We've talked about the enigmatic figure Lieutenant Colonel Gonzalez - not his real name. And it appeared that up until this outer barrier showed up that the Cabal didn't really think they were going to be stopped. Would you agree with that?

CG: .They did not feel that anything could stop them. Their allies in the realm of ETs in the Etheric world were too strong. Their gods were at their back, and we were just useless eaters that were throwaways, and there was no stopping them.

DW: Can you tell us what you know about the awakening of the stasis being or beings that seems to have taken place? Why was the Cabal interested in these stasis beings, and what happened when it woke up?

CG: Just like when the spheres started to appear in the solar system, they thought they were the Sumerians gods returning.

DW: They thought these spheres – the stasis beings were?

CG: The spheres beings.

DW: Oh. Yeah.

CG: They also thought that the stasis beings, they had been visiting and worshiping and thought that they were also their gods. And as they started to revive, they were disappointed once again. These beings were waking up and were confused and upset, and from what I'm told, were then sent off with another group that may or may not be ETs, to rejoin their people, which, I don't know if this is accurate information or not coming from this source.

DW: So if the source is correct, then this was a very major disappointment to the Cabal.

CG: One of many.

DW: They thought one of their gods was going to wake up and basically save their butts from whatever was happening.

CG: Right.

DW: And they did not get what they wanted at all.

CG: Right, and this once more demoralized the Cabal. And one of the strongest Secret Space Programs, the ICC, after the recent meeting with the Draco White Royals, where the Draco White Royals had offered up all of their human followers in exchange for them to be allowed to leave the solar system outside the outer barrier, the ICC was starting to capitulate on a few things. And after a lot of information was released about the Mars slave colonies, that was a major PR headache for the Cabal and the ICC.

DW: This sounds like the Cabal was expecting that they were going to tell the truth at some point. Or is it more they now have to tell the truth, and they're concerned about how it's presented?

CG: Well, at this point, they already know that a large percentage of very high ranking "Cabal" secret Earth Government and secret Earth Government syndicate members, had defected with a lot of information similar to what Snowden had, and they were joining the Alliance, the Secret Space Programs Alliance, and agreeing at some point to testify against them. And pretty much they were seeing and hearing that there was going to be a giant data-dump in the future of all this information about their crimes against humanity. And a strange offer came up from the ICC through a negotiation that they wanted to prove that things were not so bad on Mars as had been claimed through recent reports that I had released and others were beginning to talk about on the Internet, about the "slaves colonies" on Mars, that these people were there on their own free will, that they were happy, and that they were doing important work.

DW: So in a sense, the ICC version of the Cabal is now anticipating multiple whistleblowers that have very high level knowledge that are going to come forward and incriminate them greatly. And because of the importance that they see you as having, they want you to be given a show that would try to ameliorate your concerns about it and make everybody seem like they're all holding hands and singing "Kumbaya" on Mars.

CG: It wasn't all about me. It was more of a show for the Secret Space Program Alliance council's representatives, being Gonzales and myself.

DW: I guess one of the problems that some people are going to have with this is - if this space program's mission is so important for the Alliance, why would they throw you out here like a canary in the coal mine? Why wouldn't they deploy five different people that all know what you know at once, for example?

CG: I was told – and I've expected before now, more to pop up. And I'm challenging you now out there, those who are out there – start coming forward! There are plenty of people out there that know a lot of what I've been speaking about. And, as I've said in the past, I've watched many in the past that have talked to you, even, walk right up to the line, stop, and about-face, and then disappear out of public. And there a lot of people that know this information or compartmentalized pieces of this information that can come forward, and I believe will be coming forward, with similar information.

DW: Yeah, and actually the first guest that we wanted to have on the show "Disclosure" was Henry Deacon. And I had personally paid for his ticket to fly out here, and then right before he was going to fly out here, right before, he got very severely threatened. And that torched the whole thing. So, part of, perhaps, why more people haven't come forward is just the severity of force and coercion that is used to try to stop this from getting out. Because I've spoken to several other people that know a lot of the same thing that you know, none of them wanted to come forward.

CG: It's time.

DW: So the ICC is not just presenting this for you and your readers on the Internet. They're anticipating that you're like the first pebble of an avalanche that's going to hit them. And they want to do this show for the Alliance as a whole.

CG: Right. And this was in anticipation also of these data dumps. And they're wanting to start putting a spin on the situation.

DW: Just a recap that in case somebody missed that episode, you said the NSA was hacking all the Space Program stuff. They were..

CG: Well, what Snowden has gotten his hands on, the NSA had made one of the cardinal mistakes of putting all their eggs in one basket. And they were overconfident. And they had all types of information

they were using to blackmail politicians and people all over the world. And they had Secret Space Program information all highly encrypted.

Snowden got a hold of that and booked it out of the USA. And the information he had been sending over satellites for some time. He didn't just have a small hard drive in his back pocket when he fled. It was tons, terabytes and terabytes, of info.

DW: I've heard the same thing.

CG: All of that has now been fully decrypted very recently.

DW: As in June 2015, thereabouts?

CG: Yeah, just very recently. So all of that – they are still going through it. It's just recently been decrypted. And then we have all this - tons and tons more other information in these recent hacks that people have heard a little bit about. And so this is the information that the ICC is worried about. And this gets us to why they offered to have sort of like a NATO-type inspection of one of their colonies of “our” choice on Mars to inspect the condition, living conditions, of the colonists.

DW: How many colonies on Mars are you aware of there being?

CG: There are dozens of colonies, facilities, and industrial plants that build technologies. And a lot of these colonies are in the outskirts of these plants. And the people are shuttled to them to work.

DW: Well, I guess it would make sense if you have a whole planet that there would be dozens of facilities on the planet.

CG: And it was one of these types of facilities that we were taken to, to do an inspection of.

DW: So, let's talk through the story, starting with - you're at home. Were you given a call by Gonzales or something to tell you when this was going to happen?

CG: Yes, I was warned that it was going to happen. I didn't anticipate the timing right. I walked into my living room. I hadn't gotten dressed yet. And the little blue orb friend of mine, flew in through my sliding-glass door, patio door, zipped right through the glass and started zipping around.

DW: How big was it at this point?

CG: It's about this size. (2 inch diameter)

DW: And does it look like a golf ball, like a round ball kind of thing?

CG: mmHmm. (yes) And I knew I wasn't going to be able to walk back into my bedroom, get ready and all that.

So, I basically stand there, I put my hand like this (arms open with palms facing up), and I mentally let it know - I'm ready. And it zips right about 18 inches for my chest, expands. I am now floating in the middle of it. And it's kind of like a weird time/space blur as it, whoosh , takes off.

DW: And what's the sense of duration when that happens? How long are you in it for?

CG: Moments.

DW: It's very rapid.

CG: Very rapid.

DW: You don't experience a sense of movements or stars?

CG: No. There's a sense of movement in the beginning, but all of a sudden, you're at your location. And there's a room that I've become very familiar with at the LOC. It's a very large conference room. Since then, it's been used so often for this type of coming and going of not only myself but a lot of the civilians that have been brought up to do whatever they're doing there. But that's a different subject.

DW: Did the Space Programs ever tell you if they have a way of locking the Cabal out of that area so that it can't be spied-upon? Why would this area be secure?

CG: No. This is a facility that has to be... it is a shared facility that sometimes we don't have access to because the Cabal groups are using it. But the main table has been scooted against the wall for months now to give a larger area of the conference room open.

DW: Just so more people can come in?

CG: Right, because there's been a large number of people in there at one time, like 70 or more people. And so, I appear there. Shortly after I appear, one of the security personnel comes in. And I tell him I need something to wear. He asks me what size am I and he looks me up and down. And he leaves,

comes back, brings back a... usually when I'm not prepared I'm given used-type clothing. And this was very, very crisp.

DW: Has it at least been laundered?

CG: Yeah. It was a very crisp jumpsuit and a brand new pair of boots almost exactly like these, that have the zipper on the side for going through security points where you can pop them off real quick, and then zip them back on with laces on the front that were brand new, had never been worn. But I was just standing there in shorts, t-shirt, and wearing flip-flops. So I was totally unprepared.

DW: So, you get dressed.

CG: So, after I've gotten dressed, I was waiting for a little while. And security personnel came and escorted me to one of the launch bays, or the areas where they keep the shuttle craft. And as I walked out, I saw a semi-circle, a group of people standing, talking. And Gonzales saw me coming and kind of acknowledged me, and I saw the ICC representative standing there. And there were a bunch of the Secret Space Program councilmen standing there, basically kind of wishing a good mission, hoping all of this was a success - political kind of talk.

DW: The ICC chairman, is that an extraterrestrial? Is that a reptilian or something?

CG: No, this was a human being. He was an ICC councilman, like a high up.

DW: So what does he look like? Could you describe him?

CG: Yeah, he had gray hair, grayish-white hair, was not a real stocky guy, was wearing one of those suits that I have described.

DW: Like the Nehru jacket?

CG: Yeah, Nehru, the India, kind of. I don't know why those are so popular, but that seems to have become the thing to wear for the people in power. So we get onto what I've described. They come in different sizes between 40 and 60 feet long – shuttle craft. And they are modular on the inside. I've seen them changed out for all different types of uses, including troop transport, medical. This one was set up obviously for a VIP situation. It had enough seats for all of us. And once we sat in the seats... and I have a very long report online about this. I'm abbreviating it for the show. Gonzales was doing most of the talking. He is an impeccable politician. And I mean, he has all these skills of dealing with these

types of people. I really had been out of the loop. I was really listening to see if I was going to get more information than I'd been given. Before I knew it, we had stopped pretty far outside of the Mars orbit. We were stopped. And when we did, a giant – almost, I would estimate, about 70 inches diagonally, panel came down. It was one of the larger versions of the smart-glass pads. And a three dimensional image of Mars appeared. And all these different icons started appearing to where there were these Mars bases.

DW: How many icons were there?

CG: I don't remember now. There were quite a few, at least a dozen. There were a larger number. We were only seeing one side of Mars at this point.

DW: Were they in the Northern Hemisphere or the Southern Hemisphere?

CG: These were all up in the Northern Hemisphere. But this ICC guy started pointing to the different ones, making recommendations of ones we should visit. And at this time, Gonzales said: "Well, wait a second!" And he didn't touch anything. I guess he had some sort of mental component way activating this new icon down in the Southern Hemisphere. And when he did, the ICC representative immediately, kind of, straightened up and was disturbed. And Gonzales said: "We've chosen this facility." And the ICC representative was obviously a complete politician. He, very quickly on his feet said: "This is not a working facility. It does not have a colony. It's old..." I think he was saying it was like an automated facility. "It's not something you'd be interested in." - playing it down. And Gonzales immediately said: "Well, one of our recent defectors lived on this colony, and we have very fresh and detailed intelligence about this facility. This is the one we want to visit."

DW: I bet that is going to throw him into a panic.

CG: He was concerned. The ICC representative was concerned. And he excused himself to go back into one of the modular rooms. And apparently he had some sort of communication device or a way to communicate. And he said he had to get it cleared. And he appeared a few minutes later and said that it was going to be approved, but it was going to take about an hour to have everything cleared and the airspace cleared and have it all worked out – obviously time for them to clean up the base and make arrangements. So, approximately 50 minutes later, one of the crew said: "We're cleared for landing." and off we go. As we entered the atmosphere, we saw outside the clear panels – pink and lavender, purple discharges around the shielding and we flew real quickly toward the ground, which was

exhilarating and then cut real hard and started flying along the surface into what looked like, used to be, part of a river water feature. And there was sort of a cliff wall, kind of like a cliff wall, and out of it came – a cylinder, rose up that...

DW: It was metallic?

CG: Yes. That was basically air traffic control. And then an opening opened up that wasn't visible before in the side of the canyon-type wall. We slowed down and flew inside. As we flew inside, there were bays on each side. And on each side, there were two crafts on either side of a catwalk that I hadn't seen before that were somewhat teardrop shaped and chrome colored. And I believe it was the third bay on the right, we were apparently cleared to land. And there was one of the teardrop shaped vessels, and then kind of a large circular area for us to land, which our craft barely fit on. And we landed.

The ICC representative got out of our craft and jogged – half running, half walking to a security people that met him, went to the security checkpoint, and then came back, running doing this (thumbs up), that everything was okay.

And Gonzales and I had two security personnel, that were IEs assigned to each of us, that were allowed to carry firearms. We disembarked. We headed to the checkpoint. The security at the station told our security: "No weapons past this point."

There was an exchanged between Gonzales and the ICC representative that, this was supposed to be already a part of the deal. The ICC representative went and talked to what was the leader of the facility.

The leader of the facility scowled and did this to motion us through (to come with his hand). And we entered into the base. And there was no one present. And he said that the main hall was being prepared for the presentation. And the rest of the ICC personnel were on their way.

They had been informed of the location and that we were going to be sent first to the industrial complex to see where a certain component was produced. And then, they put us on a train, a small train that was very narrow, and was two people across to where I sat across – we sat across from each other just like this.

And the way we entered in – there were quite a few of the colony's security personnel that were accompanying us. And I had one of my security (people) on each side of me. And across from me were five of the colony's security.

And as we were heading down very quickly – it was about 8km I think I heard them say, to the industrial complex – I was asked where I was from. And I made the mistake of saying “Texas”.

Well, I left out before, we were told that as we had landed, before we had entered into the checkpoint, the ICC representative told us “Listen, this particular base is a part of a social experiment that’s very important to humanity. Please don’t contaminate it! They were told that Earth was inhabitable..” from some sort of catastrophe of something, and that the only people, human beings, that survived were those on Mars and in the Space Program. So, I had pretty much messed up.

DW: Wow.

CG: Because I was recently sunburned and I had put on aloe and all kinds of stuff. I reeked of Earth, I was told.

DW: Do they all use similar hygiene products?

CG: Yes, they use all the exact same hygiene products. Gonzalez told me later on my deodorant, the lotions I used, the hair gel, everything – I totally smelled alien.

DW: So what happen on this guy’s face when you say “Texas”, and he thinks that the Earth has been destroyed?

CG: Well, the few in front of me immediately were like (glares)– you know, and they looked at each other. And they immediately started talking amongst themselves. And then my security guy, and the security guy next to him started talking. And the next thing I know, I see Gonzales’ poke out and his head crane over and look in my direction, and I didn’t even look at him. I just looked past the security guy and watched the blurry wall going by out the window until we stop. And then, we got out to begin the tour of the facility.

DW: What did Gonzales – when he looked at you, -- what was the...

CG: I didn’t look at him. But he approached me very quickly afterwards, and he said he was thinking how he could salvage the situation. He was going to try to think of Texas being a secret facility or a secret vessel or something like that to try to save the situation.

DW: Do you think they were shown some sort of fake Hollywood style movie?

CG: Who knows? But what I do know is..

DW: That they believed it absolutely

CG: Yes. What I do know is that many of these people, especially during the brain-drain era and a little after, were being brought in, coerced to join these Mars colonies being told that the Earth was about to go through a catastrophe; that they were the best of the best, they were “special”, and they were a part of a “continuity of preservation of the human species” program to basically colonize Mars and eventually terraform Mars and restart the human race.

DW: People who are millennials and who’ve grown up buried in texting and smartphones may not realize how much of a threat people from yours and my generation and then our parents’ generation really believed there was to going to be a nuclear war. I mean, it was a very frightening, scary thing.

CG: Oh yeah, I remember. We both were at the age to where “duck and cover”,— get under your desk.

DW: As if that’s going to do anything.

CG: Right.

DW: So do you think that they may have been told that there had been a nuclear war since there was so much fear that it was going to happen?

CG: I don’t know what they were told, if it was a solar event, a war, or a super-volcano. Who knows?

DW: But, what a great way to keep people from wanting to escape, because that’s their home. They’ve got nowhere else to go.

CG: Yes.

DW: Interesting. Did these folks in this particular colony or these other colonies have contact with different extraterrestrial races or were they predominantly by themselves as humans from Earth?

CG: Some of them definitely worked with different ET races and saw different ET races. A lot of these bases were doing commerce with ET races. So I’m assuming so, but I’m not positive.

DW: I know that you didn’t live there. But, I’m curious if people had, for example, a sub-shuttle system similar to what they have on Earth, so that they can travel throughout these bases and colonies. Was there like an Internet on Mars that they could all access? Did they have the ability to talk to people in different facilities?

CG: No. I didn't explain the train system very well. It was almost like vitrified rock. And it was rippled like glass.

DW: That is exactly what I've heard from at least 2 other insiders. They have these boring machines that use some kind of nuclear energy, and they drive forward, and they melt the rock. But then they have to stop and create a little ring, because if you just go straight through, then it'll crack, and dirt falls in. They stop it periodically; make these little rings that reinforce the strength of the tunnel.

CG: It was like ribbed rippled.

DW: Then you go. Okay. Perfect.

CG: And there were cross sections where we went – as we were going along, there were crossing tunnels. And they had connections to other facilities to where they would bring in parts, or whatever else they needed.

DW: Do they have any contact with each other on the planet?

CG: They have limited contact with each other, it appears.

DW: Only high ranking people, not the rank and file staff?

CG: I would say “need to know” kind of situation.

DW: So, they're living a very isolated life. It's not like they have a big social circle.

CG: Very regimented life.

DW: So what happens next?

CG: So we were starting to begin the tour. There was this one colonist that was there that was showing a completed curved component that was a neurological optical interface that was really popular to be used in different craft.

DW: What would that actually do? It's optical and neurological? Does it track the movement of your eye or something?

CG: Well, no, through other technology, you neurologically interface it, and it interfaces other technology and gives some sort of optical display or something. We're really about to get started. The

machinery, the robotic automated machinery that builds it, they were talking about the different shapes. Some are curved. Some are straight.

DW: Is this like a helmet that you wear?

CG: No, no. It's like something that goes into a vessel. And we were just starting this when – and the train had left after we had gotten out. And..

DW: This is the industrial part of the tour they said you were going to get.

CG: Right.

DW: Were there a lot of people around?

CG: No. At this time there was just this one colonist that was apparently like a foreman kind of a guy that was there to give us a talk. And the ICC representative kept touching his ear. And he was scowling, looked concerned, and was kind of standing back.

DW: Oh, you're saying it's like an ear piece, not that he was trying to non-verbally signal to the colonist guy.

CG: Like an earwig. They put them in your ear, and you can hear, and you can talk. But it's not easy to see.

DW: Okay, so he's got his own little earwig.

CG: Right, and the facility security team was more and more looking at us, talking amongst themselves. It was obvious that they were chattered amongst themselves.

DW: Because of the Texas thing.

CG: Because of the Texas comment.

DW: And you smell funny, and you looked funny.

CG: And I had a sunburn. I was peeling. Even my scalp was peeling. I'd just had a haircut. I'd been in the sun. And I had put aloe Vera all over myself. And another train arrived. And a whole – like, double the size – a huge amount of security came out and came and disarmed all of their own security team

that had accompanied us. And the ICC representative came and told us that we needed to be very careful what we talked about and to remember the agreement.

DW: Were they worried that the guy that you said Texas to was going to frag and shoot you? Is that why, him and his team, were disarmed, because they were worried about some sort of psychological break?

CG: Well, the way they were putting it across to us, was that we had contaminated their social experiment. And then half of the new security group escorted the old security-facility group into the train and left.

And shortly later, the train came back. We got in it and headed back. Because they said that the main hall had been setup and that the ICC representatives had arrived and were ready for the presentation.

So, we headed back. And, when we arrived back this time, there were people everywhere, where before it was just noticeably empty. And in these places, you use every square foot of space.

So, to have a huge area like that with no one around was unusual. Well, all of a sudden, now there are all of these colonists. And they were obviously wearing their "Sunday's best", some of them wearing all different types of one-pieces, some of them wearing khakis and blues and all different colors, some of them actually wearing two-piece types of clothing.

And they were all doing their work, but they were all trying to make eye contact with us. It was kind of obvious that they had been told that a part of the deal was that we were going to be allowed to bring one family back with us to question about the conditions of the facility.

So they were kind of just hopefully trying to make eye contact with us.

DW: Sort of like going into a dog and cat shelter.

CG: Right.

DW: Wow. So sad.

CG: There were two different parts. We got to do a tour where the people lived and see their small quarters where the people were smiling and looking all happy.

DW: Could you describe one of these quarters just briefly for us? Like, do they have a place where they cook? Do they have a bathroom? Do they have different bedrooms?

CG: They were like jail cells.

DW: Really?

CG: Yeah. Into the walls, they had beds. And they did not prepare their food there. They all went to one central location to eat. And they went to one central location to go to the bathroom, and to bathe and all that, or shared locations for groups.

DW: Wow, did they have a toilet in the room even?

CG: No.

DW: Wow. But there's no bars on the doors? They can come and go if they want to.

CG: Right, but I'm sure..

DW: How big was the hallway?

CG: The hallway was fairly wide. I mean, it was big enough for six people side-by-side.

DW: But, is it just like rooms like this all the way down?

CG: It was, yeah, just rooms like that all the way down.

DW: No window or anything?

CG: No. No windows.

DW: Did they have light, like floor lamps, or ceiling mounting light, or how did it light?

CG: There's a type of sonic lighting that they have.

DW: Sonic lighting

CG: Yeah. It's pretty common. It's, sound waves that produce light.

DW: Where are they?

CG: On the ceiling.

DW: Is it one area of the ceiling or like the whole ceiling just glows?

CG: The panels of the ceiling, the whole ceiling.

DW: Wow. Cool.

CG: And so, Gonzales made a mental note of the, I guess the habitation number or address of one of the places, unbeknownst to me. We also went to what Gonzales referred to as a “dog and pony show” that the ICC put on. What they were calling the main hall or this gathering place looked very much like a place where people were brought in and fed propaganda.

DW: Did you get an intuitive feeling of that?

CG: Yes. It had been set up with chairs around. And there was another one of those very large smart-glass type of screen.

DW: So, it’s like an auditorium where a bunch a people could be.

CG: Yes, it was a very large auditorium.

DW: Did they have something like TV in their houses? Was there anything they could watch?

CG: Uh-Uh, not that I saw, not unless it’s retractable.

We go in. Some introductions are made. We sit down. And they give a “dog and pony show.” They start to show us all these different technologies that they barter, and trade, and sell, basically to ETs.

DW: Is the ICC representative giving you the presentation at this point, or does he have colleagues that are also working with him.

CG: Different colleagues, yeah. Different guys, they’re giving presentations. They’re very proud of what they’re presenting. There were different craft, different components of craft, different just small – they were presenting just a whole lot of different technologies from the micro to the full product.

DW: Was there anything that really jumped out, that surprised you that you didn’t know existed or that was really kind of cool, unusual, unexpected?

CG: Well, not really, other than the fact that, there were actual vessels that we were engineering and building that advanced extraterrestrial groups were interested in procuring from us. I mean, we'd come this far in producing advanced technology, that other groups wanted it? One of the things that jump out at me the most was the fact that one of the ICC representatives announced that we were doing trade on a regular basis with nearly 900 ET races.

DW: That's astonishing!

CG: And that was on a regular basis, and that we were occasionally doing trade with far more.

DW: Far more, as in thousands?

CG: Right.

DW: Whew. Did they give any sense of how much of the Galaxy this covers? Is it just a small area?

CG: No, no. I'm not exactly sure where all these groups come from. But considering that just outside of our solar system is a major hub as far as a portal system that travels through the cosmic-web of portal systems – this is like an oasis stop-over. We see a lot of traffic through the area. Most groups don't stop by our Solar System, because it's seen as very messy. With the slavery going on and all that, most of them don't want to deal with this. They stay outside of our Solar System. They do their calculations and whoosh, they go. But the ones that are amoral or don't have a problem with it, come and do trade with the ICC.

DW: By the time you saw this “dog and pony” show, had you already been told that these technologies were all going to be handed to humanity after this big disclosure takes place?

CG: Right, we had already been told that the Secret Space Program Alliance was told to stop any attacks – no longer attack the ICC infrastructure, to stop the violence. They were already having problems swallowing the -- “be more loving, be more forgiving, raise your consciousness.”

And all of this stuff to them was just totally foreign information. But they were told to stop all the violence. And they did. Especially after they found out that all of this infrastructure after the great disclosure events and people had dealt with certain things on Earth, all this infrastructure was going to be handed over to humanity to be the foundation of a “Star Trek” type of civilization.

DW: Which sounds exactly like what so many ancient cultures and modern channeling traditions all say, is this big epic golden age that we move into. So this is a very interesting practical realization of that.

CG: Right. And the Sphere Being Alliance was saying: “Quit wrecking things. Quit destroying all the infrastructures. You’re tearing up stuff that, after all these changes happen, are going to be handed over to the people.”

DW: Wow. Was it a surprise to Gonzales or others that were part of his detachment that there were 900 groups that were in, as you said, constant trade with the ICC, or did they already all know that?

CG: I seemed to be the one that was the most surprised. I usually seem to be the one that’s most “in the dark” about everything in every situation. I do not get all of the intelligence that all of the SSP alliance members get.

DW: So, in the time we have remaining, there was obviously some very unpleasant stuff that happens to you after this. So, how do we get from you being in this room to where all starts to take place?

CG: Okay. To abbreviate it, after this point, we now are allowed to choose a family to go with us. Gonzales gives the address on the wall of the family that he had chosen. And the intuitive empaths earlier had stated something didn’t feel right when we were in the train coming back.

And I felt something was off, but I’m not as in-tune as I used to be. Then once the family had been escorted onto our vessel, once we’d seen the family, the intuitive empaths were whispering to Gonzales.

And he was like: “Hmm, Mmmm.” And when we got onto the vessel, the door closed, and he said: “You’re safe. Everything is going to be okay. You can tell us. We know that there’s a member of your family missing.”

And it was a husband, a wife, and a son and a daughter. And the father was like: “How could you possibly know that?”

And he said: “These gentlemen have abilities.”, and “..just tell us what is going on, and we’ll straighten it out.”

And then, the family clammed up. And Gonzales got, in his normal way, very ticked-off. And him and his two security personnel left the craft.

DW: So, they must have told the family, you tell them that this is a wonderful place to live and everything is happy, or else your kid “gets it”.

CG: And that you want to come back. Because, part of the deal was we were able to offer them a place.

DW: Sanctuary.

CG: Sanctuary. Yeah. So Gonzales left. And, long story short, next thing I know the crew comes out of the crew compartment at the front, saying: “We have security personnel coming in fast, weapons at the ready, what do we do?” And they’re asking me.

DW: So you’re in this ship that you’re about to leave with the family in, Gonzales is trying to get their other kid, and these guys come in running with weapons drawn, and they’re basically, like, assaulting your craft, it appears.

CG: They were on their way. They had rounded the way, and they were on their way up the catwalk. And I said: “Is Gonzales with them?” And they said: “He’s nowhere to be seen.” And I said: “Stand down. Open the door.” And they immediately started taking security steps to wipe all the information, intelligence information that would aid the enemy, I guess, out of the craft. So they did that very quickly. And the security team came, disarmed our security.

DW: Where they yelling at you, and did they put your hands behind you back and hurt you?

CG: They escorted us in a very brisk, rough way. But they weren’t trying to break our arms or anything. They escorted us back past the security point. And, as we went in, the ICC representative that had been with us before was in a “yelling match” with the facility leader. And the ICC representative outranked this facility leader by a lot. But this guy was “ticked off”.

DW: The facility leader?

CG: The facility leader was upset. And we were walked to this wall. And there were now doors where there were not doors before. And they opened the doors. And there is a detention facility. And we walk in. And there are all these people in cells. And there are cells with.. they’re almost like cages that you can put your hand in like this, with octagonal kind of holes. And they walked us all the way back. All of

them have people in them. And, in the very back is a larger cell with Gonzales and his two people, with his two intuitive empath guards. And they put the rest of us in, including the crew of the craft. And Gonzales said that the facility leader was a tyrant and couldn't handle being challenged in front of his own people, that things had gotten heated and out of control, and they were detained. And he said things sounded like they were going to go very, very badly.

DW: Meaning you guys were going to be held for a short while and murdered?

CG: It sounded like things were going to go in that manner.

DW: Or tortured first and then murdered?

CG: Who knows? He didn't elaborate. We were in there for a short time. And the next thing we know, all these blue orbs started appearing in the cell through the walls. Gonzales and I were the only guys who had traveled in this manner.

The other people, the security and the crew, were kind of backing- up a little bit. They were a little bit taken off guard. Gonzales just told them to indicate that you're ready to travel, and the spheres one-by-one just appeared around us, and we zipped through the walls and appeared back in the room that I mentioned before with the table slid against the wall - the conference room.

And an intrusion alarm went off, because we weren't expected back in that way. Our craft got left behind. And Gonzales sent the rest of the people to be debriefed, and told me we lost a vessel, but at least we didn't lose any people. And he didn't know whether I was going to go see the Blue Avians after this, or if I was going home, but that he needed to go.

So I took off my boots, took off the jumpsuit, and put on my flip-flops, and the blue sphere came. I indicated I was ready. And I was brought home. And that's basically - end of story. There's a much longer story on my website

DW: People online had asked if the family was able to have been taken with you.

CG: No. We have no intelligence on what happened on that facility to that family. I've had zero information on what occurred.

DW: Some of the attacking comments have been, why do the Blue Avians not care about these slaves? Why are they not saving these slaves? Isn't there going to be something in the future where they will be free?

CG: Yeah. This is a part of a much longer conversation. There is a plan to where when all these people are freed, they're going to be brought to another place to where they can be rehabilitated, and the same thing for a lot of the Secret Space Programs Alliance people. A lot of these people, like I said, are not angels. They're very damaged people. And they're going to be brought to one of our allies who are going to rehabilitate them before they're returned to society.

DW: Well, thank you very much. You're very brave for going through this stuff and not giving up. And thank you for watching. This is "[Cosmic Disclosure](#)", I'm your host, [David Wilcock](#). We have much more coming up for you, and we thank you for watching.

[Cosmic Disclosure: Global Galactic League of Nations](#)

Season 1, Episode 8

DW: This is [Cosmic Disclosure](#). I'm your host [David Wilcock](#), and I'm here with **Corey Goode** who has worked for over 20 years in the secret space program, got out in 1987 and now has been pulled back in, in a very interesting way. After coming forward as an insider he has been contacted by an alliance that is claiming that it wants to take the almost supernaturally exciting technology and way of life of the space program, break down the walls of secrecy and bring it back here to Earth. So, **Corey**, welcome to the show.

CG: Thank you.

DW: We've been talking about the factions of the space program in earlier episodes and we've covered them to varying degrees, but as I was mentally going through our notes I realized that, although we covered it superficially, we never really talked that much about the Global Galactic League of Nations group.

CG: Right. I always referred to them as the NATO-type group.

DW: You were always saying 'NATO-ish', I remember that. So, to open this up a little bit, let's think about this one – we now know that Joseph Stalin was well aware that “Roswell” was, in fact, a crashed “saucer”, because that's what it was announced as. And then, all of a sudden, the US government says “oh, it's only a weather balloon.”.

CG: Easy mistake! (laughs)

DW: So, I did some episodes for Ancient Aliens, in which part of the research that I went into, was that Stalin hired people to go back through the records, and what they found was - somebody had dug up a weird rocket in Siberia that had Sanskrit written on it and it was all metallic. The rocket, they couldn't get it out of the ground without damaging it, it was in the late 1800's, so they just left it buried, they reburied it. So, after Roswell happened, Stalin apparently dug up this rocket. It was so advanced, they couldn't make any sense out of it. But apparently there was also a chest in there and the chest had all these documents that included really elaborate blueprints and diagrams of spacecraft, how to build them and space stations. Really really “cool” stuff. And it was from that, that the Russians were able to develop, what are called “Cosmospheres”, which are spherical flying... ah, you're nodding your head, have you heard of the Cosmospheres?

CG: Yeah, absolutely!

DW: What do you know about those?

CG: Russia, The Soviet Union used that as their way of forcing their way into some of the secret space programs. Of getting involved.

DW: What is a Cosmosphere? How does it work? What does it look like?

CG: They were spheres, metallic spheres that Cosmonauts were flying around in, in outer space. And our spacecraft were seeing them and tracking them back to the Soviet Union. And it was very concerning. And it caused us and them to open more of a dialog.

DW: How large were the Cosmospheres? How many crew could be fit in there?

CG: They had different sizes. They had them for, I believe, 1-3 people, and even larger ones.

DW: Let's take a look now, at a video clip. This is going to be upsetting for some people who are a little older and remember this personally. The Space-Shuttle Challenger blew up in the air. And what

you're about to see is a video of a spherical UFO, taken by a cameraman who filmed the challenger blowing-up, and you'll see it right here.

(video plays - see below)

DW: Now, **Corey**, I don't know if you're familiar with this, but Lieutenant Colonel Tom Bearden (retired), claimed that the sphere was a Russian craft, and that they had attacked the Challenger on take-off. That this was part of this secret war, Cold War stuff going on with advanced technology. They were doing this to try to strike at the United States. Did you ever hear of that incident?

CG: We were already working together with the Russians far before that happened.

DW: Hmmm.

CG: The Cold War was, pretty much, a gimmick.

DW: Like a fundraiser.

CG: Yeah, I guess you could call it that. But, the people on the ground, the lower-level people were very much into it - it was real for them. But, when it came down to it, the Soviets and the Americans were, very much, allies.

DW: Well apparently it was only recently declassified – somebody posted this as a comment on my site after I wrote about the Manhattan Project, that the United States never was able to enrich anywhere near enough uranium to actually make the atom bomb. And that they got the rest from Nazi Germany.

CG: MmHm (nod)

DW: So this kind of stuff makes people go crazy. Because we've grown up fighting these great nemeses and in WWII, even the women were getting involved in making bombs, and the threat of Hitler had captivated the whole world in fear. And you're saying that all this stuff is a big elaborate circus?

CG: One of these days, whenever there is data-dump of the true history of what has happened in our world, people are going to be dumbfounded, and angry.

DW: So, do you think that this is why the Soviets almost immediately had the A-Bomb after the USA had it, even though the USA allegedly had done such a classified project? That they just traded the secrets with each other behind the scenes?

CG: You know, that's all very lower-level ground-level stuff going on. When it came down to it, they were already working together in space because of different perceived extraterrestrial threats and they were working together to keep, as well as they could, which wasn't very.. it was kind of silly to think that we could protect the planet against these super-advanced extraterrestrials, but they were forming an alliance well before the Cold War, in space, to start protecting the Earth.

DW: Do you think that was the basis of Ronald Reagan's infamous speech about an alien threat unifying the world?

CG: Yeah, I guess it could have been. But, like I said, far before that we were already truly allies with a lot of the people that we have supposedly been enemies with.

DW: Let's take a quick look at that clip now of Ronald Reagan.

Reagan: I couldn't help, at one point in our discussions with, privately with General Secretary Gorbachev. When you stop to think that we're all God's children, wherever we may live in the world. I couldn't help but say to him: "Just think how easy his task and mine might be in these meetings that we held, if suddenly there was a threat to this world from some other species from another planet outside in the universe. We'd forget all the little local differences that we have between our countries and we would find out, once and for all, that we really are all human beings here on this Earth together"

DW: So, you said though, that these Cosmospheres are kind of sneaky and annoying to the Space Program? So, how much collaboration was going on with the Soviet Union?

CG: In the beginning there was very little, but it became apparent, not only to the Soviet Union, but to all of the countries of the world that there were secret space programs going on.

DW: It became apparent at what time?

CG: In the late 50's and early 60's it was becoming very apparent. It was just obvious. And, ... the Soviet Union and all the big powers started working together, but all of the smaller countries, now that they're knowing about it, how are you going to keep them quiet? They wanted to be a part of this "saving the world". Be a part of this secret space program.

DW: Were there intelligence services for some of these countries that were capturing and interrogating people, perhaps under very strenuous means and obtaining information through unethical practices like that? Is that part of how this was happening?

CG: They were obtaining information in any number of ways, including - We had agreements with all these countries that, any time a UFO crashed in their country, we were allowed to send in our retrieval teams.

DW: How early was that treaty made?

CG: That was going on in the late '40s, the '50s and '60s.

DW: That early? Wow!

CG: Yeah, we were retrieving UFOs that were crashing in all these small countries. So, I mean, they couldn't keep this a big secret. They didn't have to “put the screws” to a person really to find out what was going on. So, what happened was, they formed a secret space program, or a program for, that I called up until recently, the NATO-ish-type group. And it wasn't until I was in one of the Secret Space Program meetings at the LOC, that it was referred to as the Global Galactic League Of Nations. And, that just sounded like a really hinky name to me. You know, the “League of Nations”, you know. But that's what they were being referred to as.

DW: Well that's the precursor to the United Nations, right? This is like post World War I type of stuff - Treaty of Versailles.

CG: And, this group was formed, I guess kind of as a carrot to all these other nations, to keep them quiet and to make them feel involved in protecting the planet. They were told that there were all these different threats to the planet and that they could be involved in the solution. And they were provided bases and technology, but they were based entirely outside of the solar system.

DW: So who, in these countries, were lucky enough to be privy to this little world? Is this, elected officials, people like prime ministers and presidents, and cabinet ministers?

CG: I am not sure who of these countries knew about it. Just about every country you could imagine is involved at some level in this space program.

DW: So, do you think that it may have more to do with high-level intelligence agents in these countries and defense contractors, the military, high-level military personnel – the people who out-last individual administrations and elected officials?

CG: Yes and a lot of scientists.

DW: Hmm.

CG: It seemed like a lot of scientists were involved.

DW: What about bankers and bean counter, number-cruncher types running the financial system?

CG: They seem to have their finger in everything.

DW: So, walk us through, as much as you know about. You said this began in the '50s, '60s. How were these people approached and what do they see? How were they brought off-planet? What did they actually experience? How much did they get to know?

CG: This program was a fairly recent one. It didn't start back in the '50s and '60s. Back then is when they started to find out what was going on.

DW: Okay.

CG: I believe this was something that started probably, at least, in the '80s maybe even '90s. It's fairly recent.

DW: Hmm

CG: And I am not exactly sure of all the specifics of what propaganda they were fed, but I have been to one of their bases and I described briefly in one episode, one of the bases, but we didn't go super in detail about it.

DW: So let's do that now. Did you travel there by a craft or did you travel there by a portal? How was the method of arrival?

CG: Strangely enough, this was the underground tram system that you hear about. This underground tram traveled through a portal, came out on what was a moon around a gas giant in another solar system. And then stopped, and then we disembarked.

DW: It was on rails when it stopped? It was in like, a room?

CG: It came out of the tube and was hovering above a track.

DW: Hmm. Well, my space-program insider Jacob described portaling in a sub-shuttle system and he said that it's so fast that most people don't even bother to sit down because all you do is stand there, hold the pole, sshhht, and then you're out.

CG: See. I've been talking about going through a portal in a train and people have been telling me that I'm the only one that has ever said that....

DW: I heard that back in 2009/2010.

CG: Okay. People have been telling me that it's ridiculous, that no one has ever said this before.

DW: This is one of hundreds of things that I never put online so I can figure out who's who in the zoo.

CG: Okay.

DW: And you just verified it. So..

CG: Okay. So, as we disembarked..

DW: It's hovering how far off the ground?

CG: Off of a track, it's not far, just barely off the..

DW: Just some kind of little gravity system or something..

CG: Like a Maglev kind of..

DW: Okay.

CG: So we get out, and as we get out the first thing you notice - you hear announcements in English.

DW: And you see the Sky? Are you indoors?

CG: No, it's... immediately we are in what is like a cave, like a grotto kind of area.

DW: Okay.

CG: And, we hear announcements in English, just general announcements.

DW: Is this like a tropical moon with lots of lush vegetation, and water and rainfall, or..?

CG: Well, all we could see at this moment was just the cave.

DW : Okay.

CG: And we could see people walking around. Their body language, they're walking in 2.. two together. Maybe groups of 4 – 2 and then 2 behind each other or 3. Very relaxed, they seemed.. it was just very relaxed.

DW: Are they wearing shorts and flip-flops or..?

CG: They were wearing jumpsuits with the flags of their countries on their shoulder and very much like what is depicted in “Stargate Atlantis”.

DW: Hmm. What color were the jumpsuits? Did they have different colors depending on rank or position?

CG: Different colors, but.. blue seems to be a big standard.

DW: What color blue?

CG: I guess the color that the Air Force uses a lot.

DW: Like a light-blue?

CG: It was like a royal-blue.

DW: And you said that they had flags of their country?

CG: They all had all these different flags, from all these different countries.

DW: So what countries did you definitely recognize?

CG: Many of them I didn't recognize, but later, I recognized flags from countries like Estonia, and just countries that... the Ukraine and...

DW: Latvia?

CG: Yeah, stuff like.. you know, flags that I never had seen or would recognize.

DW: Anything from Greece, Morocco, Algeria?

CG: People from those countries were involved, but I can't recall all the flags that were seen. I didn't see thousands of people. I only saw a certain group of people – the group of people that I saw.

DW: Any countries from Africa, like Nigeria, or Chad or Congo or Niger?

CG: There were people that looked to be from Africa, but I wasn't running around peering my head around people's shoulders - that would be too conspicuous, but people were obviously from everywhere. And..

DW: So, South America..

CG: Right.

DW: Most of the “Five Eyes” right? The big western countries - New Zealand, Australia, Canada, they were all represented?

CG: Right, anywhere you can think of.

DW: Wow. And you said they looked happy and relaxed?

CG: Yeah.. It was nothing like..

DW: That doesn't seem normal from what you've been describing.

CG: No, the Mars colonies that we had visited, we were walked around by armed guard. We were told not to make eye-contact, speak to anybody. The people looked very gaunt and very stressed-out and unhappy. These people - 180 degrees difference.

DW: Hmmm.

CG: So as we got off the train platform and were walking towards where the cave had been sealed-off by a giant metal-type wall with an entrance that you'd go through to go to security, we looked to the right – there was a big cave entrance, going out. And it was like sort of a tropical kind of environment. And the different times we had been there, there were moons that were at different places in the sky.

DW: How many moons do you remember seeing at any one time?

CG: Two.

DW: Okay. Were they larger in their apparent diameter than Earth's moon?

CG: Depending on their position, yeah, they looked larger.

DW: Did they have any unusual color or surface features?

CG: Orange, one looked orange. And I really can't remember the other one because we could only just see part of it.

DW: Did either of them have a ring or anything 'funny' like that?

CG: No.

DW: Could you see the gas-giant planet that this was supposedly orbiting?

CG: I never saw.. I didn't see the gas-giant.

DW: Hmm

CG: But I was told it was around a gas-giant. But there was a strangely blue luminescent pool. If you were looking out, straight out of the cave, to the left, there was a strangely blue luminescent pool with a little bit of a waterfall trickling down in it. And..

DW: Like, built into stone? Like natural rocks?

CG: It was all natural, this wasn't man-made. And ..

DW: But the blue, that sounds man-made right? It's has some kind of weird glow?

CG: No, I think this was an actual..for this planet.

DW: Unusual thing, in nature?

CG: Right. And there was kind of steam that just stayed real close to the surface of the water, and there were people out there laughing and talking and having R&R (Rest and Relaxation) getting in the water.

DW: So, this isn't like the "Chronicles of Riddick" where some horrific creature comes up with a tail and "kaahhh".

CG: No (laughs)

DW: A very safe, happy place?

CG: Right, they were having R&R, having fun, getting in the water..

DW: They have, like, beach-chairs around? And that kind of thing?

CG: No.

DW: Towels, the people..

CG: The people, they had towels and swim-wear, and they were getting in the water, swimming around, getting out..

DW: People having fun in a space-program colony?

CG: Yeah, they were having fun.

DW: (laughs)

CG: And then, to the immediate left was a big wall, where you walked through to go into the actual facility, to where people were going in to do repairs.

DW: What kind of equipment was being repaired?

CG: Certain types of lab-equipment that were involved in testing. It was different each time. It was highly.. specialty equipment that usually the ICC had produced. Either the ICC or the scientists that were assigned to the research vessels were proficient in working on.

DW: What was the “mojo” about this spot? You were told it was outside our solar system?

CG: Right.

DW: So, was there something unique or valuable about it? Was it near other places where other races had lived? Did it have tactical significance?

CG: The “scuttlebutt” (gossip/rumor) was that it was in the Pleiades.

DW: Oh, really?

CG: And a bunch of us didn't believe that. But that is what was said. But for some reason.. “the Pleiades” seemed to be this kind of stamp that was put on everything - “Oh, this came from the Pleiades”, that was “from the Pleiades”..da da da, “Pleiades”, “Pleiades”, “Pleiades”. So, it got to be, oh, “this place is located in the Pleiades” - Oh, okay, that again. So, that's what was told, but who knows where it really was.

DW: Given the fact that there's seven stars in the Pleiades with a fairly bright magnitude, that are all in a relatively short amount of space next to each other..

CG: I'm told it's a larger star-cluster than that.

DW: Yeah, those are the seven, like I said, the seven most apparent magnitude of brightness of two or higher. Are you familiar with whether being on one of these stars in the Pleiades, if it actually is the Pleiades, because the other stars are nearby, would they be larger than stars usually looked to us in our solar system?

CG: When it comes to point-of-view, where you are. If you're, say, you're in the Pleiades, and you're looking at the sky, you have a whole new set of constellations. Nothing looks the same.

DW: Right.

CG: So, your point of reference is totally thrown-off. There's really no way of being able to judge really where you are - even for the “eggheads” without the right equipment. When you arrive somewhere, either if you don't know the address of where you are being sent prior, or you don't have the right equipment that tells you where you are – you don't know where you are.

DW: Well, let me ask you this then, to just kind of, warm this up. You go to a binary star-system, let's say.

CG: Most of them are.

DW: Okay. Do you see two suns, if you're on that planet, in the sky?

CG: It depends on the relationship of the binary star-system. But, yes, you can see a faint star in the distance.

DW: But it's not as big as some of the movies that we've seen would have it? It would still be pretty faint and distant?

CG: Some of them are real close together, but these stars, the closer they are together, the faster they spin around each other, and the more dynamic the system is. The ones that seem to have more life on them are the stars that are a little bit further apart but are dancing in a gravitational dance together.

DW: Let's go back to this base now. When you walked off into this sealed-off grotto, was there anything about it that looked 'cool' or futuristic that would have made these people feel like advanced location, or was it all fairly conventional, other than this weird glowing pool that you saw?

CG: They had much of the newer tools and toys of the ICC. I think they were given a lot of new 'toys', technology to make them very happy.

DW: Hmm.

CG: And they seemed to be doing, just, a lot of research. Tons of research, these people.. its a derogatory statement, but they often referred to the scientists as “eggheads”, and they would say “they smelled of egghead”, as eggheads. But these people were obviously scientific or engineers. Scientific personnel or engineers for the most part.

DW: Approximately how many personnel did you see walking around while you were there?

CG: Just out, immediately, there were probably 3-4 dozen.

DW: Okay.

CG: And there was not a large security-presence. I did not see a lot of people running around with weapons. It was just very relaxed and laid back. Wherever they were, they felt very secure and the energy, the feeling.. The intuitive empath – the feeling of all the people was - there was no anxiety, there was no agitation, they felt happy, they felt like what they were doing was important, and they just felt.. there was a feeling of happiness and just, relaxation.

DW: Well, we're down to our last 5 minutes, but I want to throw a few quick ones at you, just to round this out. Did you see a hangar that had any type of unusual craft in it that they could use to fly-around with?

CG: They had a hangar, but we didn't go to the hangar.

DW: Did they have any land vehicles that they would use to venture out from this grotto to the rest of that moon?

CG: Not that I saw. I didn't see any type of tracks. Inside they did have some battery-powered trucks. Small cabbed trucks that were driving around with plastic crates in them, in one area.

DW: Did the moon have an atmosphere?

CG: MmHm.

DW: It did? Was it breathable?

CG: Obviously. People were out there, outside the entrance of the cave. There was vegetation, people were..

DW: Outside the cave there was vegetation?

CG: Right.

DW: This is not some arid moon, because when we think of a moon we are usually thinking of a big dead orb.

CG: No. Many of the inhabitable spheres that are out there are not planets in the Goldilocks Zone, around those stars. They are moons within a certain density and size that are orbiting a gas-giant, in a certain orbit of a gas-giant that is a certain density and size. And that gas-giant can be any distance from it's sun.

DW: How big would the gas-giant be on one of these moons? What's the scale? Could it be actually something so large that it fills up half the apparent diameter of the sky that you're looking at, at one point? Or is it farther away than that?

CG: I would have to be speculating. I haven't seen, myself.

DW: It would appear that some of Jupiter's moons, if you were on one of those, that Jupiter would be very large from what you could see.

CG: Right.

DW: So that would be a very interesting place to live.

CG: I believe that these inhabitable moons would need to be a little bit larger than some of these moons, and a little bit further away than the orbits of the ones around Jupiter or Saturn, because of the tidal forces they have to deal with, being in so close to Jupiter.

DW: What are “they” told they are doing? What are they preparing for? What is their mission? What is their objective?

CG: They are told that they are coming up with science and technologies that will help the planet Earth in case of, or in preparation of, an outside alien threat. Just like we heard President Reagan talking about. And that President Reagan clip may have been meant for this group.

DW: It sounds like it. So, they are essentially trying to establish a defensive foothold to save Earth from what they perceive as an incoming threat?

CG: I don't know if they are setting up a foothold, but I think that they're working on science and technologies that they fervently believe will help humanity protect the planet Earth.

DW: How much knowledge do you think they have of extraterrestrials? Are they kept in the dark? Are they told similar to the military faction - “You guys are it, and everything else is ancient, but there may be some out there that we don't know about, and we've got to defend ourselves if they show up”. Is it something like that?

CG: From what I've found out since all of this has happened - they have been heavily compartmentalized.

DW: So they really don't know anything about the full spectrum of what is really going on?

CG: They know some of the “spectrum”, but they do not know as much as some of the other programs.

DW: So this is like a little “mushroom patch” for the space program.

CG: Right. Compartmentalization – the lie is different on each level and each compartment. Everyone in each compartment is told: “You are at the top of the totem pole. You are the tip of the spear for the planet. You should be very proud of what you're doing. No one knows more than you. You are very special, very special. You have been cleared to know more than anyone else on the planet.” Everyone in every compartment is told the same thing, and they believe it.

DW: Well, it seems to me that this is a perfect way to keep the opposition silenced, by giving them some biscuits and saying: “Here, here's your tasty treat, now go leave us alone - off on this moon somewhere else.” Well you've heard it here. This is [Cosmic Disclosure](#) – very mind-blowing information. And there's much, much more where this came from. We have 52 episodes, and we may even be doing more past that point. So, every week you're going to be hearing fascinating stuff like this, so please “stay tuned”. I'm your host [David Wilcock](#), and we thank you for watching.

Cosmic Disclosure: Electric Sun

Season 1, Episode 9

DW: I'm here with **Corey Goode**, the insider who has come forward with a remarkable story of the military industrial complex colonizing our solar system and beyond and having extensive interactions with a multitude of extraterrestrial beings. And, **Corey**, welcome back to the show.

CG: Thank you.

DW: Alright, let's just start with a basic question. Throw this at you and see what you do. What is a star?

CG: A star is definitely not what we were being told it is in school – a giant ball of gas on fire out in the middle of space.

DW: Right away, you've just slapped all the skeptics in the face because they say "it's scientifically proven – he's an idiot."

CG: It has not been scientifically proven. It's scientific theory.

DW: Right. We see stuff coming off the sun that would imply it's got hydrogen. There's hydrogen atoms coming off and oxygen and things like that.

CG: Right. When I was assigned to the research vessel there were expeditions to the sun, to where probes were shot into the sun and they would shoot these probes into sun spots.

DW: The first thing would be how do you get a probe into the sun without it burning up?

CG: Energy field around.

DW: So, very high-density energy field that shields it from being burned up.

CG: Right. And also collapsed from the gravitational....What was seen from the telemetry that came back from these probes was amazing. The sun is electric. The people that are talking about the electric plasma model of the universe, they are correct.

DW: But that model usually excludes torsion fields.

CG: Yes it does. There is some stuff that needs to be... some information that needs to be married. Obviously torsion fields are involved and not only the stars, the planets, the galaxy. I was shown that our entire universe is a giant torsion field.

DW: Why did they pick sunspots and not some other place?

CG: The telemetry from the inside of our star, Sol,... (**David** asks.. is that what they call it, Sol?). That's what it's referred to. There was a core that was very small and they could tell it was made up of magnesium, sodium, I can't remember all the elements.

DW: Mostly metallic?

CG: Yes. And the outer shell was made up of similar materials but it was like a node and a cathode. So it was an electrical.... almost like a light bulb. And the sunspots were going into the center of the sun like vortex filaments streaming into the center of the densest part in the middle of the star.

DW: Like a tornado, and energetic tornado?

CG: Right. Tiny, thin little tornado spirals crisscrossing each other, spinning around, crisscrossing each other and going and meeting down to the small center.

DW: It does make sense because a lot of times when we are looking at sunspots we see actual rings burst out of the sun, tubes of energy. It's called a solar prominence and you have this ring come out and you're saying that's not just on the surface, that those go way down right to the core.

CG: Right to the core and these are also at times depending on the sun's behavior, stargates, that are utilized by different extraterrestrial groups to go in and out of our solar system. And there was a wide open empty area inside the sun. Now, there is a very large area outside, on the inside area. I've described that as molten and on fire. And they found out it was hotter.... It's hotter on the outside of the sun and cooler on the inside.

DW: That is something available to most people the corona, which is actually above the surface, is hotter. And that's considered a scientific mystery. But the electric universe people account for that with the idea that the sun is an electric energy generator.

CG: Yes and the sun, or Sol, is being fed by some sort of waves that are hitting it. And that is what is causing the outside to be so active. And also, it is being fed through what I describe as the cosmic web. Each sun, each star is connected to every other star, through this cosmic web. And each one is connected through a filament, electromagnetic filament that we were describing that connects each star. So, things can happen in one solar system to one star and there can be feedback through the system, this network that can affect our solar system star.

DW: In my third book, I wrote about a pyramid researcher named Joe Parr. And he has a propeller with little pyramids on the end, that are only an inch long. And he rotates this thing through a series of opposing magnetic. He's got north to north, south to south, north to north. And what happens is, at certain times of the year, where the sun and the belt of Orion and then the Earth crosses to that like it's a gate. And it happened in late December. The pyramid on the end of the propeller would transmute out of physical reality. They'd pop through the walls of the centrifuge and come out like a shot gun blast. And they'd actually embed into the wall and there was no visible exit hole. So he came up with a theory that there was some sort of energy conduit that affects the nature of matter when our earth is crossing this beam between the sun and Orion, which happens once a year in the earth's orbit. So you think it's possible that these plasma beams could do that to matter? Could actually change the face of matter like that?

CG: Absolutely. That also goes back to this hyper-dimensional mathematics model that was handed down to us, that we use to calculate portal travel. With every star and planet and galaxy having a relationship with each other, you have to be able to calculate these things. Because you can have weird little hiccups that can cause weird things, like what you were talking about in that experiment.

DW: Pete Peterson has brought forward mathematics and I met the guy who actually did it. I can't say his name because he doesn't want to come forward, but he basically calculated that the whole universe is Penrose tiled, meaning everything has an intersection of three lines. And if you count on base six, meaning you go one through six and then you go two comma one, two comma two, two comma three, two comma four, two comma five, two comma six, then three comma one, three comma two...like that.. if you calculate in base six, then all of these numbers, like Pi and Phi, they all become integers. They don't have a repeating decimal anymore. Do you think that these hyper dimensional mathematics operators that you were given are, in some way, taking that into account? Is that the kind of stuff that was going on?

CG: It unifies, basically, all of these scientific principles that our mainstream science has problems with. And until our mainstream science drops their theories and begin to embrace the fact that the universe is a plasma electric universe and a torsion universe – both are true – these are the science that Secret Space Program base their technology off of. They are not going to progress any further than we are now, using this eighteen and early nineteenth century technology.

DW: Since we're talking about math, I'm thinking about now, the basis of superstring theory, quantum mechanics, all this stuff that the skeptics are going to try to use to attack us and say, oh well, it's all been proven. Almost all the math that goes into superstring theory was from this Indian mathematician named Srinivasa Ramanujan. He was a genius who re-derived a hundred years' worth of western mathematics on his own with one book and came out with all this stuff that nobody knew what the heck it was, called "modular function". And basically, what he is saying is geometry is the key to these higher dimensions. Now, they're still using all that stuff in superstring. Nothing has supplanted it yet. The important part is that Ramanujan said that the Hindu Goddess Namakkal was teaching him, all this stuff, in a dream. So you think that various benevolent extraterrestrials have been trying to seed this knowledge in our society.

CG: Yes. The higher dimensional beings have been trying to get us to... I was told that our lifetimes are very short. We basically die as spiritual children. We were meant to live much longer and have a much longer of a time to spiritually develop.

DW: When you say I was told, who told you?

CG: I was told this by Raw Tear Ear.

DW: One of the Blue Avians.

CG: Yes. At the time of our death, we are spiritual children. And that's if we live a very long, hearty life. So we need help in these short lifetimes to advance, to get some advancement. And we are receiving help from higher dimensional, our higher density beings to be given information in dreams and in other ways. To help us progress, at the end of what they are calling a major cycle, to where we need to get, to where we need to be, quickly.

DW: Was the term "major cycle" used in your own communication with the Blue Avians?

CG: They called it.. we're at the end of a major cycle.

DW: That's exactly what they called it in the "Law of One". That's something we never discussed before. It's another correlation. Getting back to the science of time, when they sent these probes through the sun, did the probes go somewhere else? Or was it just that they mapped the interior out?

CG: It mapped the interior out. It sent back telemetry until it succumbed to the forces inside the sun. It was basically a little suicide mission for this probe. It was meant to go in, gather data, and send back telemetry, as long as it could.

DW: One of the things that strikes me, is your describing a rocky metallic core, with a cloud around it. It sounds sort of like the description of Jupiter or Saturn, in terms of what we know is in the center. Is there a relationship between a star and a planet based on what you were told?

CG: There's a relationship between a star and every planetoid in existence, an electromagnetic filament relationship. Anything that has a large enough density to twist space-time in a torsion field creates a relationship with a host star. And it creates a filament or an electromagnetic connection to its star. And each planet has a core that is the driving force, depending on how active the core is, of how strong that connection is.

DW: In my original book "Source Field", I described the work of John Martineau, who wrote a really fascinating, ground breaking book called "A little book of coincidence in our solar system". This was crazy, because I had written this whole book and it was at the very last minute and I got this book handed to me, and I had to change the whole book and add a chapter just on this guy. So here's what he has done. He looked at the relationship of the planetary orbits to each other. And he's found that they perfectly described by a series of nested geometries. Most of these correlation – and where talking

about Platonic Solids, so we're talking cube, tetrahedron, icosahedrons, which is a twenty sided with equal little triangles, it looks like a disco ball. Dodecahedron, which is pentagonal, twelve pentagonal faces.

CG: These are a lot of the symbols that show up in this hyper-dimensional mathematic models.

DW: They draw the symbols of the platonic?

CG: Yes. There is a few numbers and there is a lot of symbols, a lot of these geometric platonic solids and a lot of other things are symbols that are in this mathematics model.

DW: That totally makes sense. All the modern superstring people are using Ramanujan's model, functions and they're mapping them on platonic geometry, and they're saying these modular functions are decryptions of geometry. So the geometry is already in the hyper dimensional math. It's just that people don't usually know that.

CG: And it's focusing too much on the quantum physics, when really we found out that everything is just vibration – is a vibratory state. And once we really realize that everything around you is a vibratory state and time and matter and space can all be manipulated, once you realize or learn how to do it, learn how to manipulate the vibration, the vibratory state of everything around you, then all of these other sciences that all of the doubters are saying are proof that what I'm saying is wrong, it all fades away.

DW: This is something that if people are watching our show, there's so much great scientific information in "Wisdom Teachings", that you could spend a whole year of your life just getting into. One of the things I talked about is Dr. Robert Moon who was one of the founding fathers of the atomic bomb, one of the single most important scientists in making it work. In 1987, he discovered that the proton, in the atom, were actually corners of geometry. And he totally maps it out. And I have multiple episodes when we go into all that stuff. And I highly recommend if people are interested in this, that they check it out.

CG: Basically, what I've said and what I've been talking about, Gaiam is that it's more of an online university.

DW: It's a parallel university.

CG: Yes, it's an online university of content. I had no idea that this type of information was already out there until I started looking around.

DW: But the reason why I wanted to bring in Robert Moon is we're kind of getting into the unified geometric model now. So we have Dr. Hans Jenny, this European scientist who vibrates water with sand in it. And you vibrate the sand and you get sacred geometry. What does that tell us? Geometry is vibration. Vibration creates structure. And this geometry, which is in all these dimensions, is the structure of vibration. So it's exactly what you just said.

CG: And he is being totally ignored by mainstream science?

DW: Of course.

CG: This is information that is being suppressed. And this is not just a theory that I'm tossing out here. This is working science that is being used in the Secret Space Program and has been used for a long time. And a lot of this information has been handed down to us by extraterrestrial races that are millions of years ahead of us technologically and have been using these concepts and sciences and mathematical models for eons.

DW: It was almost a hundred years ago that Rutherford shot electrons through gold foil. And some of them stuck. And that was what made him say it must be a particle. Because he's shooting these things through and some of them don't make it through. That's called a Rutherford model of the atom. It's a little solar system and there's little planets whirling a nucleus. Did they laugh at that Rutherford model in the Secret Space Program? Did they think people were nuts for thinking that particles were solid?

CG: Well, yes. Because we also know that consciousness has an effect on the outcome of every experiment. If you took someone who had a pre-conceived idea that everything is a wave and they start doing these experiments, they're going to have the outcome that everything is a wave.

DW: I think that when we bring in Moon, we've now got a geometric model for the atom, meaning that matter is a vibration. This just solves this right there.

CG: Everything is a vibration, as I said, thought, light, everything around us. They're all different states of vibration. And even our consciousness and especially our mass consciousness can change the nature of the vibration of matter and our reality around us.

DW: One of the things that Secret Space Program Jacob told me that the reason why people used to have to look into a crystal ball or a mirror to see and communicate with spirit is that we believe that spirits don't exist. So they won't be allowed to be seen right in front of us. But we can bend the rules, if we see them in a mirror or in a crystal ball. We can say well, maybe that's a reflection or something like that.

CG: Going back to "there is no spoon". (smiles)

DW: So is it true? Have you also heard in your work what I've heard from other insiders, which is that one of the greatest secrets from us is that reality is a co-creation generated by our consciousness.

CG: Yes. That's one of the largest secrets that they tried to keep from us. And they've tried to suppress. There's been many scientific experiments that has proven this. And they suppressed those. They've suppressed the scientific information about the electric and plasmatic universe, about the nature of space and time. They've suppressed torsion physics. They've gone really heavily to suppress the effects of consciousness on reality. They've worked heavily to suppress.

DW: All the way back in 1936, there's a scientist named Otto Hilgenberg, who had a very compelling model that the earth must be extending and that all the continents fit together if you take out the oceans and then shrink the earth down to fifty to sixty of its current size. There's been many other scientists since Hilgenberg who have come forward with even further details. (There's a video imbedded in the interview that shows how the continents fit together if you shrink it down and remove the oceans. You might be able to view the video if you Google Otto Hilgenberg). What happens if the Earth is expanding? What does that do to our science?

CG: It turns everything on its head. If a planet is expanding from the inside that would go against what mainstream science is saying.

DW: Well, it would mean that matter is being continually generated from nothing, right? The Earth itself is growing, like a living thing.

CG: Right. And of course, the earth is constantly accumulating an extreme amount of cosmic dust and debris all the time, tons and tons and tons a day, that are coming through our atmosphere. This is also adding to the density of the planet.

DW: When we go back and we look at the John Martineau model of the solar system, what we're seeing is that as the planet moves, there's a giant geometry that covers its entire orbital size. And the geometry is moving with the planet as it rotates. So, what you're describing with these stargates forming between the planets is very likely, that these geometries we're talking about have an electric charge. And when you line up the nodes, you're getting a plasma filament.

CG: You stole the words right out of my consciousness. They are called nodes. And the Earth, everyone knows about ley lines and that the earth has an energetic grid.

As the Earth is rotating and depending on its relationship in space to the sun and the behavior of the sun, that depends on each of these where they cross and depending also on the elements of what's underneath, underground. The type of stone, or crystal, metal under mountains or under the ground, creates a node. And that's what they call it – the node. And a stargate will appear along these nodes, either on the surface of the Earth, just below the surface or in the upper atmosphere above in the node regions. And they focus on these node regions to look for where these natural stargates are going to open. And they watch for these also for intruders, extraterrestrials that would appear in our skies. And strangely enough, many of them were appearing along the thirty three and thirty six parallel north. The node system in that area seem to be where they were coming and going quite a bit.

DW: In most of my talks, I cover Ivan T. Sanderson, and he is the source of the Bermuda Triangle scholarship. Charles Berlitz, actually was the one who wrote the book "The Bermuda Triangle", that put that into the public consciousness. But he was only drawing off of Ivan Sanderson's research. Sanderson found ten points around the Earth where all the ships on the sea and all the planes in the sky were disappearing. And they all clustered around the same points. This was published in 1971 and then in 1972, the Russians figured out that if you add the north and south pole you get a icosahedron. It's a perfect, sacred geometry on the Earth. And then the future scholars from there, found that the dodecahedron is also perfectly nested in with it. And when you put those two shapes together, and you draw those lines over the Earth, it tells you where the continents are.

CG: There was a sphere to represent the Earth and they placed these different shapes inside of the sphere to where the points were coming out like 19 degrees here, at different points of the Earth's rotation around the sun and also different times of the sun's cycle. They would use different shapes inside the sphere to represent... (**DW:** so you're saying that some of the geometry would actually come to a point above the surface of the Earth? And those lines would cross in the sky somewhere?) Right.

(DW: and that's where the node was or the portal was?) And that's where the node – the predicted nodes – would be.

DW: Is this the kind of stuff that the German's were using? Getting back to what we talked about before, where there'd be a sphere and then they'd send tanks through or whatever?

CG: No. These were holographic depictions... that were used in a different era.

DW: When we're talking about the geometry of the grid, why do you think planes and ships disappear at these nodes?

CG: They're in the wrong place at the wrong time. When the cosmic web activates a particular node region and they happen to be in that region, when it goes active, and these are natural portals, they're in the wrong place at the wrong time and they've portalled. And they are very bizarre. Depending on where they are in the region of the portal, they could be portalled in time or space. So they could be portalled into a different time on Earth or somewhere else in the Galaxy or beyond.

DW: That actually makes sense to me, because the physics model that other insiders have told me what they called "layered time". We want to see time as this thing that's all stretched out, but if you think about the solar system itself as a geometry, then each geometric ratcheting point is actually all stacked in on itself, like an onion. They're not actually apart in time. The geometry all folds together. It's all nested like multiple tetrahedrons that lock up at certain points.

CG: You see geometry depicted in all parts of these different black ops programs and the secret space program. Geometry is popping up everywhere.

DW: So if the past is in one geometry and our now is in another, and then those two forms lock together, you could have a portal that pops you through all these different layers of geometry that we think of as separate points in time. But they are all actually in the same space. It's not really space, but absolute space.

CG: One of the scientist egg-heads said that figuring out these nodes and the geometry and the cycle of the sun, the sun's eleven year cycle, it's activity, sunspots, flares and our position in our solar system was like having a galactic Rubik's cube that you're trying to figure out real quickly.

DW: Let me ask you a strange question. As if this isn't really strange!. Are any of those geometries outside or inside, meaning future or past, or are any of those other geometries, real? Besides the one we're already in? Are there other geometries at all? Or is there only one real geometry?

CG: They are all real, and they are all happening at once. Because time is an illusion. There is no beginning, middle and end as we experience time.

DW: But when something happens in our history, we write the history books. It's not like the books are changing as far as we can tell.

CG: This is how we experience time, with our third-density minds. Time is all at once, happening. And it's a hard thing to try to communicate to people that time is not linear, that time is an illusion and that it's our consciousness that is causing time to be experienced in a linear way.

DW: That is a difficult adjustment.

CG: Yes, it's very difficult to try to make people understand...

DW: Well, speaking of time, we are actually out of time in this particular episode. So we actually have to quantize things into a half an hour. So, what's going to happen here, is, in the next episode we're going to get into one of the subjects you have told us you're the most fascinated about in your comments, and that is – the stargate in your brain, the pineal gland, the third-eye. We're going to talk about that, coming up next time here on [Cosmic Disclosure](#), because you need to know. I'm your host [David Wilcock](#), and I thank you for watching.

[Cosmic Disclosure: Awakening the Pineal Gland](#)

Season 1, Episode 10

DW: Welcome to "[Cosmic Disclosure](#)." I'm your host, [David Wilcock](#), and I'm here with **Corey Goode**, an insider who has come forward claiming to be from the secret space program having access to extraordinarily classified information, much of which is completely new to even the most seasoned veterans who have studied UFOs, insider testimony, classified intel, all this kind of stuff. In this

episode, we're going to delve into one of the subjects that you have consistently told us, in your comments and by what you've watched on the internet of my videos, is the most fascinating subject for you. I'm talking about the glandula pinealis, or the pineal gland. So **Corey**, welcome back to the show.

CG: Thank you.

DW: Could you, in your own words, explain for our audience what you heard about the pineal gland. What is it? Does it have a function for us? What is the pineal gland?

CG: When I was in my lab program and I was identified as an intuitive empath, they were giving us injections and sonic treatments right here.

DW: Injections where?

CG: In our shoulders.

DW: Okay.

CG: And our hips. When we were younger, they'd give us injections in our hips. When we got older, they would give them in our shoulder.

DW: That sounds painful.

CG: You get used to it. And then there was just a metal kind of rod that came to a point that they would put right here that would send sonic waves to the pineal gland. And they said it was to enhance-- not the empath but the intuitive part of our intuitive empath abilities.

DW: Could you feel a sonic vibration in your skull from it?

CG: Yeah. You felt the sonic waves going in about a good six inches back into your head.

DW: Wow.

CG: Yeah. So it was obviously important to them to stimulate the pineal gland.

DW: Well, in the scholarship that I've put out in "Source Field," there's a whole chapter on the pineal gland. We know it's in the geometric center of the brain. We know it's the size of a pea. It has more blood flow going through it than any other part of the body except the kidneys. And mainstream

science says, oh, we don't really know what this thing is. But there are cells inside the pineal gland that actually are the same cells more or less as in the retina of the eye.

CG: Rods and cones?

DW: They're called pinealocytes, but they're the same thing. And they're also wired into the visual cortex of the brain by the same type of wiring that we have from our eyes. So the ancient traditions literally call it a third eye. And in my videos-- and we have this coming up in future episodes of "Wisdom Teachings"-- there's pine cones and that kind of iconography showing up in all different world religions.

So do you think that there's something happening inside the pineal gland that these little rods and cones are seeing?

CG: Well, they said it was to help stimulate the second sight and the intuitive abilities, and they stated that they knew that there are ancient earth breakaway groups that they've gotten their hands on who have very large pineal glands.

DW: Oh, really?

CG: And they said that at one time, all of us, our pineal glands used to be quite a bit larger than they are now. And they were trying to stimulate growth and activity in our pineal glands.

DW: Well, that's very interesting, because the insider Jacob told me that the Draco tried to engineer modern humans so that we would not have a pineal gland at all. And they got very mad, because benevolent ETs came in and reinstalled it. Have you ever heard of anything like that?

CG: Mm-mm.

DW: Okay.

CG: I actually heard that it was a part of the grand experiment from these 22 different genetic experiments from these 40 groups. This experiment was not only genetic in nature, but it was also spiritual in nature and that they were trying to enhance us in a spiritual way and that the pineal gland-- and something also to do with our light body was something that they were manipulating to try to help us become more spiritual and more developed in that way. Now, they are obviously at odds with this Draco Alliance group.

DW: So that would imply that the Super Federation is not all negative, that they are--

CG: Yeah. Like I said, it's all point of view. They have their agendas and why they're manipulating us the way they're doing.

DW: We've had multiple insiders suggest that when you see the halo around someone in these ancient pictures-- or in Buddhist illustrations, it's more like a corona-- that that would indicate a pineal gland that's much more active, and that there's some sort of light phenomena. Did you ever see anything like that?

CG: Well, when I was talking just now about our light bodies, the exercises they put us through were to not only activate our pineals, but to expand our light bodies to where they would say that when they got us to the point where they wanted us, we would be sitting in a room and our light bodies would expand past the walls of the room that we were in.

DW: Wow.

CG: So there is obviously a direct connection with the pineal gland and the development and expansion of your light body.

DW: I want to get back to those exercises in a minute, but first I want to bring in another interesting point. I've had at least four different insiders tell me that if our pineal gland is even partly activated-- never mind fully activated-- that we could literally fly throughout the cosmos. Do you feel that it is somehow a stargate, like a portable biological stargate built into our body just like hardware that we haven't accessed yet?

CG: Yeah. A lot of beings use the pineal gland and their light body to project their consciousness and their selves to other physical locations and then send that information back through that connection to their physical bodies, and then change the vibration of their physical bodies to match the vibration of the location they're at. And then the body teleports to that location and rejoins the consciousness or what some people are saying are having of out-of-body experiences or projecting their minds-- a lot of different terminology for what these more advanced beings are doing.

DW: I'm just curious. Do you think-- because this is a speculation I've had-- that the halo is actually the mouth of a wormhole and that you get gravitationally pulled up into the mouth when your pineal gland is open? You can fly up into that halo and travel through it?

CG: I think that these depictions of halos and auras that they've shown around people are just people that have really highly developed their light bodies and their pineal glands and developed their selves in a very intuitive, spiritual way, and that's the way that they've been depicted in art. And people that have also developed their light bodies in this way have a second sight and are also able to see other people's light bodies.

DW: Now, in Tibet they actually will have a long, thin, sharp piece of wood or something that they stick through somebody's forehead, and they wound the pineal gland a little bit with it. And that supposedly creates some kind of access. Do you think that they might be doing a more technological form of something like that with this sonic gun that they gave you?

CG: They're trying to find a way to stimulate the pineal gland.

DW: How did it feel when you were getting this treatment? What was your experience?

CG: You would have out-of-body experiences.

DW: Really?

CG: Yeah. You would feel your light body grow. You would feel yourself growing in all directions outside of your body. Sometimes you would feel yourself knocked outside of your body behind yourself.

DW: Wow.

CG: But at the same time, you would feel locally what was going on in your body, the sonic vibration going on into the wet brain matter behind your skull.

DW: Well, I did an episode on "Wisdom Teachings" with Dr. **Michael** Persinger, who has something he calls the "God helmet." And they've got these very powerful magnetic guns that he can triangulate and aim into certain parts of the brain. He can create extreme panic and fear. He can make you sweat. He can create sexual arousal. And there are certain parts of the brain that he beams it into where people have a god experience.

Now, the skeptics love to bring Persinger in and say that this is proof that there's no greater reality, that these visionary experiences are just a brain firing. But to me, it sounds like what Persinger's doing with the God helmet is similar to what you're saying with sound waves.

CG: Yeah, sounds like it. Electromagnetic waves were also used on us at times.

DW: So do you think that anyone given this kind of a treatment would have an experience like you had, or was it because you were prepared for with your intuitive training?

CG: I think they would have it. They would have some sort of an experience. I at a young age was already having out-of-body experiences and weird experiences. I mean, we would go on long car trips, and I would get bored, and I would project myself outside of the car. And I would project myself out and fly over the signs and over the hills and look back at the car and fly and have an out-of-body experience going on long trips. I was already doing that at a very young age.

DW: My insider Daniel went through this intuitive training for what he called the Psy Corps.

CG: Right.

DW: And it was supposedly derived from the CIA, or so he was told. And I want to kind of go through some of the things that he said they taught him and then see how that compares with your training.

So number one was inverse calisthenics. They had him hang upside down, by his knees or by his ankles, and do sit-ups. And they were told that the more oxygen was in his blood and the more blood flowed through his pineal gland, that if they could strengthen the circulation into the pineal gland in the body in general, that that would enhance his abilities. Did you have anything similar to that?

CG: The closest we had to that, they put us into pressure rooms that were highly pressurized and highly oxygenated. And they would have us do meditation, and they would hook up EEG-type electrodes to our heads. And they had trained us to go to different states, including theta. And they would, on command, tell you to go to a certain state, and they would measure how quickly you could go there at different atmospheric pressures and oxygen levels inside this chamber.

DW: Do you think this was partly intended to help you be able to function in different extraterrestrial environments?

CG: This was all during the same time when-- this all had to do with intuitive empath enhancement.

DW: Well here on Gaiam, we have a lot of yoga Tai Chi videos. And people can get into that when they're a subscriber. It's all free. It's included in your basic membership.

I always thought that the inverse calisthenics, these sit-ups upside down and increasing the overall circulation, that if you look at the ancients, they're saying yoga, Tai Chi, it's all about building circulation. It's about flexibility, all that kind of stuff. So do you think that these kinds of exercises will be beneficial to people if they want to develop their intuition?

CG: Yes. And they were also teaching us Tai Chi type stuff.

DW: Really?

CG: And it also had to do with a lot of visualization during the same time, of visualizing spherical energetic balls and making them travel and feeling them travel down different parts of your body and passing them around inside, throughout your body.

DW: Wow.

CG: Yeah. It helps with oxygen and blood flow, but also they were incorporating us using it to move energy throughout our bodies.

DW: Could you explain a little more about what exactly you were supposed to witness? Was there a color to the sphere? Was there a size to it? How many of them were there at once? Was it just one?

CG: Just one.

DW: Did they give you any specifics about what it's supposed to look like?

CG: Of our choosing. They just said, visualize a sphere, an energetic sphere, and take the sphere in your hand and then visualize it passing back and forth from your hand and then travelling all the way through your shoulders to the other hand. You would do that at first, and then you would take it, and it would travel down your spine and back up your spine up through the top of your skull.

And then you would visualize it coming back down to your solar plexus and coming out and catching it in your hands and then circulating it again. It was a visual exercise, a mental and visual exercise, of passing this ball of energy throughout your body and also feeling it.

DW: Could this just be done in a standing position, or were there Tai Chi type of movements that were associated with the movement of the sphere?

CG: You were moving your hands and body and visualizing it as you were doing it. You weren't sitting in a static position as if you were meditating.

DW: Well, there definitely appear to be Tai Chi moves that are associated with a sphere of energy like that. So could the sphere be like this big in certain cases, or is it more small, like about that big?

CG: Yeah. We were visualizing small spheres.

DW: OK. But there was no color, like blue or white or anything like?

CG: Usually like a light bulb, just white.

DW: White light?

CG: Yeah.

DW: How similar is what people see as Tai Chi now? Because most people seem to be doing the same set of movements. Would you say those movements were the same as what you were doing, or were they somehow different?

CG: Very many of them are quite the same.

DW: Oh.

CG: Yeah. And most people that are doing Tai Chi know that they're doing energetic work at the same time. People that have practiced it long enough know that they're doing energetic work.

DW: I've never been able to find it online, but there's a PBS video with Bill Moyers where he's got a Tai Chi master. And the guy's standing there, and people come running towards him. And they're yelling and screaming, and they literally just fly off of this guy. What's going on there? I mean, these people seem to be getting hit with something energetically.

CG: Yeah. Some of these people were demonstrating how they could throw these energy balls and put dents in metal.

DW: Really?

CG: And these people were really developed.

DW: When you say "these people" now--

CG: The people that were teaching us that were really advanced.

DW: Are they space program people? Are they extraterrestrial human types?

CG: No. This was back in the My Lab program. These were the just Black Ops types that were teaching the younger people.

DW: They could dent metal with these spheres that they created?

CG: Yes. Well, with the energy. A sphere did not shoot out, but they were visualizing a sphere, and they would shoot it out. And these people were the ones that believed very much in the "Star Wars" Jedi kind of-- the force.

And you wrote a book, "The Source Field." And they harnessed, I guess, what you would call the "dark side" of the source field, or the dark side of the force. And they were very much into really stuff straight out of "Star Wars," like Jedi-- I mean, like the Dark Lord Sith kind of magic energy that they pulled from the ether or the universe.

DW: Well, this gets into another thing that Danny was telling me. I'm really interested to hear where you're going to say about this-- explosive muscle movements, martial arts, this kind of stuff.

Apparently-- and there's a Tai Chi guy that **Pete** Petersen knows, and he's really about this kind of very intense tensing of the hands and the fingers like this.

What Danny was told in this training was that these intense violent muscle movements-- something having to do with adrenaline-- that adrenaline is like a magic energy conduit, and that you can't get these abilities by just doing smooth, gentle exercise. Push-ups, weightlifting, martial arts-- this kind of stuff is essential. Did you ever hear or anything like that yourself?

CG: A lot of these guys that were doing this, I didn't see any sign of adrenaline. They seemed totally at ease, at peace, and docile. It just seemed effortless for them, and there was no [GROANING] kind of a thing going on. It was just real smooth motion kind of a thing. Obviously, they were acting as some sort of antenna pulling energy from the source field, I guess you would call it.

DW: So in Tai Chi, from what little I know of it-- and actually, you're making me want to go start these videos right away, interestingly enough, because it's finally making sense to me why you would want to

practice this-- they seem to always be big on-- I've had some martial arts training, so bending your knees, lowering your center of gravity, and they talk about the hara, or the tan tien, this sort of area in your abdomen that you're supposed to feel like there's a string or an energetic cord coming up from the earth. It's sort of like you're pulling energy out of the Earth. Was that part of the training, to ground in that way with bending your knees?

CG: There was a grounding aspect mentioned of visualizing yourself grounded with the center of the Earth, and also visualizing yourself as an antenna that can pull in and push out energy, this background energy, of the cosmos.

DW: Daniel, in his training, one of the things they also taught him was that it is the Earth that empowers magical work and that the earth has to authorize you to do these things, that your energy when you start to be able to develop these feats of consciousness, you have to work with the earth, and it will authorize the action. Was that something that you encountered in your training?

CG: Well, we were taught a little bit beyond that. It all had to do with the cosmic web. The earth had a relationship with the sun. The sun had a relationship with the local star cluster. The local star cluster had a relationship with the center of the galaxy. The galaxy had a relationship with the local galaxy cluster and so on and so on.

DW: So what are some of the other things that they taught you for the intuitive training?

CG: There were a lot of other types of scenarios that they would put us through, including virtual reality, which often were very disturbing. They would put you, by yourself or you and your team, in a virtual reality scenario. And this was such an immersed virtual reality scenario that you had smells, tastes, feel. You could feel wind.

DW: Did you know once you were in it that you were in a virtual reality?

CG: That was part of the test. You would be put into a very horrific situation sometimes or asked to do very horrific things, put into battle situations with unpleasant type beings that you would have to fight. And you would have to rely more and more on your intuition to win. If you just were relying on martial arts or tactical training, you could never win.

But when you would rely on your intuitive abilities, you were able to win. And then at that point, it was almost like a lucid dream. You would realize you were in a virtual world, and then you would pull yourself out.

DW: This sounds exactly like the movie "Divergent," where you have this girl, who is thrown into a virtual reality, and she's the divergent one. She's the one that learns how to break any virtual reality and get out of it.

CG: Right. Ever since my first two audio interviews hit the internet, I've heard that many times.

DW: Also, the movie "Ender's Game," where there's the child in the space program, and they're teaching these children to fight extraterrestrials and pilot ships. He realizes early along he's getting thrown into virtual reality simulations, that they want him to be as sociopathic as possible.

And so instead of cooperating with these beings that are trying to give him a challenge, he'll like rip its eye out or something. Is this the kind of stuff that those movies seem to be related to what you're experiencing?

CG: Yes. They were not only training us, but they were psychologically profiling us as well, to see what type of orders we would follow, how far we would go. They wanted to know who were sociopaths, who would follow certain types of orders. There were orders-- [SIGHS] Yeah.

DW: Really horrible stuff.

CG: Really horrible stuff that I don't want to talk about on camera. You would see your somewhat friends, but team members, taking part in and you were ordered to take part in, and you would have to make the moral choice or dilemma whether to follow the peer pressure, do what the others were doing, or to not do it.

DW: What were some of the monstrosities that they had you fight, if you can tell us some of that? I don't want you to dredge up a whole lot of nasty memories, but--

CG: They had a very good insight into what you did not like.

DW: Ah. So it was like they deliberately target what you fear most?

CG: They would target your fears. Obviously, I did not like spiders, apparently, so I did battle with very large spiders. I did battle with reptilian type beings.

DW: And there's no way to tell that it's not real when you're in it?

CG: Right. It gets to a point where it's hard to tell what's real and what's not. And once you finally get to a point in your intuitive empath training to where you consistently are able to tell that you're put in a virtual reality setting, then you have somewhat graduated to a new level.

DW: You had mentioned to me in another conversation sometimes it was like professional wrestler types, like big strong men that you'd have to fight.

CG: Mmm-hmm. And you're a kid.

DW: But it's sort of like a bad dream, right? You don't remember getting into it, but once you're in it, it just seems like this is your reality.

CG: You would be in a scenario to where you are being put into the scenario that seemed logical. And then you're in the scenario, and you've got to fight your way out of the scenario or figure your way out of the scenario. And the only way to do so successfully was in an intuitive way.

DW: Could you get a little more specific as to how that would actually play out? Because otherwise, we're just going to have to fill in what we think and not really know what you mean.

CG: Well, if you were fighting another person, you would then instead of relying on the martial arts or the tactical training, you would then lock in on the person's eyes and make a connection with them and then intuitively know what they're going to do before they would do it.

That was one step. And when you were able to start doing that and then situations would happen, you would intuitively know. When you were going to clear a building, you intuitively know if there were 12 rooms to clear, you begin to intuitively know the first five rooms were already clear, and the sixth room was the room where you had to engage.

And then, once you started reaching this point, it started to become easier for you to intuit that you were in virtual reality. And from the very beginning, when you were put in a landing zone or put into the situation, you would immediately know that it was a virtual reality, and you would pull yourself out.

DW: This is interesting because who is doing the actions in the virtual reality? In other words, if you're psychically detecting how to fight somebody, who is the somebody? Is there a person controlling who you're fighting? Is it a computer program? How does this actually work?

CG: They're pulling information out of our heads and control them. They also had the ability to put multiple people in the same virtual reality scenario to where, at times, these people were really there together. When you were engaging with their mind, you were engaging with their mind and their chair.

DW: When you're fighting something like a tarantula, can there be a human operator controlling the actions of the tarantula, or is it a computer program like an artificial intelligence?

CG: This was just a situation that was playing out in the virtual reality. I don't know if it was artificial intelligence. It was very high-tech, and I know that they were mirroring a lot of information out of your psyche into the virtual reality.

DW: If a technology like this could be done at all, undoubtedly some people are going to start thinking about stuff like "The Matrix" and wonder how much of all of our reality is a simulation or is somehow a virtual, greater compartmentalized part of--

CG: Row, row, row your boat. Life is but a dream.

DW: Do you think that ultimately, if we're looking at the fact that we only remember one lifetime, and then it seems that we have an afterlife and reincarnation that our life here is sort of like a simulation, every time we wake up from sleep that we're jumping back into this hologram?

CG: That's probably a good way to put it. But we're definitely, from what I was told by the Blue Avians, since we're spiritual children still when we die, we're not living long enough to spiritually develop. It's taking us multiple lifetimes to learn the lessons and to spiritually develop to a point to where we can graduate to become higher density beings.

DW: Well, you've heard it here. This is "[Cosmic Disclosure](#)." Very mind-blowing information, and there's much, much more where this came from. We have 52 episodes, and we may even be doing more past that point. So every week, you're going to be hearing fascinating stuff like this. So please stay tuned. I'm your host, [David Wilcock](#), and we thank you for watching.

Cosmic Disclosure: Potential Of Human Consciousness

Season 1, Episode 11

DW: Welcome to [Cosmic Disclosure](#). I'm your host [David Wilcock](#), and we're here with **Corey Goode**, an insider who has a truly remarkable breadth of information, in a variety of highly classified projects, at the cosmic top-secret level and above, that's 35 levels above the secrecy of the President of the United States. We've been talking about intuitive training, and how the programs that **Corey** was a part of and other insiders who I've spoken to were a part of, trained you to become more psychic, to have greater powers and capabilities. And, all of this ultimately builds up to the “rainbow body” - a very interesting subject from Tibetan Buddhist meditative practice. So, **Corey**, welcome back to the show.

CG: Thank you.

DW: So, the Tibetan rainbow body seems to be the core of where all of this discussion is ultimately taking us. I have written about this extensively. For those who don't already know, in case they're new to this, the rainbow body is some sort of transmutation of the physical body at the time of death. And the core of the practice seems be – to stay in a continual state of meditation, and have every thought be a loving thought. Obviously, what you described in the previous episode is very disturbing stuff - the kind of training you said that some of these guys in the program saw themselves as like a “Sith Lord” (from Star Wars).

CG: Yes. They see themselves as masters of the dark side of the force - Sith lords. Very much of that mythos is a part of their belief system.

DW: Without getting too graphic, were they using the most negative things you can do to other people as black magic to enhance these capabilities that they had?

CG: Yes.

DW: So, you were describing people who could actually throw a ball of energy out of their hand and dent metal with it. Is this just like a little ding on the metal? What are we talking about?

CG: No. We're talking like – “majorly” collapsing, pushing in metal doors.

DW: Wow!

CG: If they were to do that to a human being, the human being would not survive it.

DW: When I was talking to Daniel before (one of **DW**'s insiders) he was describing two types of psychic - "TPs" and "TKs". TP is your telepath and TK you're telekinetic. Did they ever break it down like that in the program that you were involved in?

CG: People that had telekinetic abilities were moved into another program.

DW: Daniel was told that TKs were one out of a 1000 people, that they are a lot more rare, but that they could be trained, just like a telepath could be trained. So, did you experience the same thing, that telekinetics could be trained to become more telekinetic?

CG: Any of these abilities can be enhanced. They can be enhanced through training. They also give people chemical injections that somehow enhance these abilities. So, yes, all of these abilities can be enhanced.

DW: Daniel also said to me that they gave people a scale of psi-ability. And you had the letter "P" and then the number. So, I guess a P0 is like a typical person with no real psychic abilities or aptitude, and this would be telepath or telekinetic. A typical psychic, somebody who we would actually think of as really good would still only be a P4. But in the training that he went through, the people that got to the highest level could be all the way up to P8, P9 or P10. Which, if you are a telekinetic, apparently they would use these people to pinch the carotid artery in somebody's neck, and kill them by a blood choke to the brain. Were you aware of psychic abilities being used for assassinations and that kind of thing? Is that part of what they were training?

CG: Yes, they were using some of the abilities to train these young people to be able to kill, with telekinetic abilities. This person, did he start his training as an adult or as a child?

DW: Yes, he was working at the Montauk base. They had a peculiar way of approaching you, where they would just have somebody, seemingly start up a random conversation with you - "What do you think about E.S.P. What do you think about psychic ability?" And then, if you show interest in it, and you say that you've had your experiences and things like this, then they say "Well as it turns out there's a program, and you can get paid extra, and it won't affect your normal work hours and you're going to

be able to learn a whole lot of really cool stuff... What do you think? Do you want to try it out?" That's how they would recruit you.

CG: Well the reason I asked is that one of the reasons they created the MILAB program, is that children between the ages of 5 and before they hit puberty – if they get these kids, especially they want them very young - and if they get these children that have these abilities at a very young age, and start these training tactics on them, they get much, much, much more enhanced abilities than when they try to train adults. If you would take a person like you're talking about, that's an adult and has been trained and is on this P-scale and one of the MILABs that has been trained and enhanced since this young window, age, and then if you were to measure them on this same P-scale, they're going to blow this other person away.

DW: I believe Daniel said he only ever got up to P7 and he was a telepath. They also said something weird, which is that, TPs and TKs are like a yin and yang of the conscious and the subconscious. If you are telekinetic then your telepathic ability is subconscious and it will happen but you can't control it. And if you're a telepath then your telekinesis is subconscious and you can't control it. You either have one or the other, but not both, is what they seem to have discovered.

CG: Well, you have both but the other one is very weak. During a lot of the IE (Intuitive Empath) training, weird things would happen, with things moving across the floor and across the room when people were seriously focused on.. especially when they were being enhanced technologically in remote-viewing training and intuitive enhancement training. This was with these younger people, in this age-window that I'm talking about.

DW: One of the things that Daniel was really impressed by was the sci-fi show “Babylon 5”. And the author, J. **Michael** Straczynski featured this P-scale system in the show. And one of the things he remarked on was that some of the ETs in “Babylon 5” were like P11 or even P12. And he was told that it can't go any higher than P10. But that, obviously, is not true.

CG: MmmMmm (in agreement)

DW: That's just what he was told.

CG: Yeah, when they start people in adulthood, and start training them with these abilities, they have already missed a major window. When you are at a young age, you haven't formed all these preconceived ideas of what is possible, what is not possible. Your consciousness is more malleable, and

therefore – your consciousness is more malleable, your consciousness is the trigger to your abilities. So, these younger people are going to be able to be trained and formed to be able to do lot more things than someone that has been way past the age of puberty and into adulthood, and has an established belief system and ideas about what is and is not possible.

DW: Why do you think that these rainbow-body practices seem to require so much more work than them giving you injections and technological advancements to get you negatively empowered as a psychic.

CG: It's always a short cut. To enhance yourself and to evolve on the positive path is a very long and difficult path. The Blue Avians gave this message, for us to become more loving, forgiving of ourselves and others, to stop the wheel of karma, and to focus daily on becoming more service-to- others, and to raise our consciousness and to raise our vibrations. And, that sounds real kind of hippie, kind of flowery, easy to do, but I assure you that is an extremely difficult path to walk. When you can walk a very short and jagged negative path, and get some very strong and interesting abilities – that is going to seem like a more interesting and doable path for people.

DW: Why do you think, in Hollywood movies that it's always the evil characters that seem to gain supernatural powers, and then it's always the heroic characters who have to just fight them based on weapons, and true grit and dumb luck?

CG: Well, because in movies – who controls who makes movies? They want to promote, that going the path of hate and fear, the dark path, is the most powerful path. That's the way to get rich, and famous and powerful; to be ruthless in our society. And, to be nice is a very hard, and almost always, losing battle. A very difficult battle to win.

DW: Tibetans also had black magic, and I think people don't realize this. There were some very negative practitioners in Tibet that are described such as in books like the (Life and) Teachings of the Masters of the Far East. One of the things it talks about in there is, some of these black magic Tibetans would, if they want to assassinate somebody, they would take a knife or dagger and charge it up with an incredible amount of hatred, and then, apparently if they do that enough, the person would then want to pick up the knife and actually kill themselves with it, stab themselves with it. But they said that this was an extremely dangerous form of black magic to practice, because almost invariably, you end up wanting to use the dagger to kill yourself. Or some kind of bad karma happens to the person. So, what do you think is going on there?

CG: These are, kind of universal natural laws kicking in. If you are going to use hate and fear as a tool, then the laws of karma are going to always catch up with you. It seems like we always see, I'm not going to mention any names of politicians, these really evil, horrible people, that seem to always get away with everything, and go on and on and on doing horrible things and they are never held accountable. Well, eventually the law of karma is going to catch up with them, and they're going to get hit with it all at once.

DW: But we also see them getting hit with incredible scandals, or they get injured somehow. It seems like they are required to be there to fill a certain job description, but even within one life I don't think they are having a lot of fun.

CG: Even us, who are trying to walk the positive path, if we are not being challenged, with the yin the yang, if we are not being challenged by the dark – the more sinister side of the coin, we're not really ever going to grow spiritually. We grow through adversity. That makes a lot of people angry when you say that. They say “you know what, leave me alone, leave me at peace, and I will sit in a lotus position, and I will meditate and I will grow. And I will ascend a lot quicker than if you have me in a world to where all these negative things are happening to me.” And that is not the way things are designed.

DW: Interestingly, the Tibetans say that the worst thing you can do is to sit, meditate and be blissed out all the time. They warn that you could go into “the realm of conception-less gods” and that it is a very dangerous thing. One of the funny things that they say, is that if you are in a situation of extreme fear, fear for your life, like a pack of wild dogs is chasing you and you're running – that in that moment when you're running from the dogs, that's the closest you can get, in many way, to cosmic consciousness, to having a full breaking down of the veil of who and what you really are.

CG: Well you're never more “in the moment” and feel more alive than when you're in danger.

DW: Do you think that that's the basis of why they would put you in these horrible simulations, was to try to evoke this “yearning of the soul” to the higher-self or to God, to preserve your life?

CG: It's to have you focus on being in the moment, to focus on preservation of life and to draw on the inner energy and power that you have through your consciousness; that is 'built-in' to help you with preservation of life.

DW: What do you think is going on in these documented cases - you don't hear about them as much anymore, it was prevalent in the '70s - like a mother whose child is trapped under a car, and she literally lifts the whole car off the child. What do you think is happening in a case like that?

CG: Well a lot of it people say it's adrenaline, and they have done tests that prove adrenaline has something to do with it, but a lot of it is, they say, mind over matter. But I say “mind over what's the matter”. It's consciousness. And our consciousness is extremely powerful. And more than likely what is happening is, our consciousness in that moment of the now, is changing the physics or the matter around you, changing the reality, to where you are changing the outcome of that situation.

DW: My space program insider, Jacob, told me that those people who documented those cases were often secretly abducted and blank slated and tested in secret. And what they found was that these people have some kind of DNA energetic overload, and it actually damaged their DNA and many of them would die within a few years of doing something like that, because it seems to have messed up their biological mechanism somehow.

CG: They spent all of their life-force energy in one kind of blast.

DW: So you would agree that, that might be damaging to us at this level if we try to jam that much voltage through all at once?

CG: If we're not spiritually evolved enough to be able to handle it, yeah.

DW: So is there a way to positively generate that kind of connection, so that we can handle the voltage increase without it breaking us?

CG: Well yes, and we're having to do that now. With.. Our solar system is entering a highly charged, energetic part of the galaxy and we're experiencing high energy right now that is affecting the psyche of people all around us. It's obvious.

DW: Well it seems like people are going through more stress in less time than ever before. Life is getting increasingly difficult.

CG: And time seems to be compressing and speeding up. And the people that are working on becoming more service-to-others, raising their vibrations and consciousness, opening their minds up to this type of information, are going to be far more prepared and able for this type of transition than those who are more service-to-self and exploiting other people.

DW: The Germans, you said, went to Tibet and grabbed scrolls and people that knew how to read them, which you said actually had blueprints to make vimanas, correct?

CG: UmHm (yes)

DW: So if they're encountering these cultures, where every thought is supposed to be a loving thought, and that gives you magic powers, how in the heck did they get a black magic spiritual philosophy out of this? I think some people might have trouble understanding how that could have happened?

CG: Well they brought their ideas and their beliefs and overlaid them onto wherever they went. They constantly.. they corrupted what were even positive symbols, positive teachings and ideas, and twisted them and turned them into negative ideas as we well know from the history that we know.

DW: So what do you think a Cabal type of person's reaction is going to be when he hears you say “be more loving, be more forgiving”?

CG: They are going to cringe (chuckle). They want us to be always anxious, always fearful and always at each other's throats. They want us to be divided, religions against religions, races against races - as long as they can keep us at each other's throats, we're not at their throat. They divide and conquer us.

DW: Were you personally aware of social programs that were intended to foster that type of condition in humanity?

CG: I want to be careful because they have co-opted and used religions that are based on this very love principle that I'm talking about. This golden rule principle, “do unto others as you would have them do unto you.” They have infiltrated a lot of these religions, and twisted them and taken control of them and started to use them in hateful ways, and (in) ways to divide us.

DW: Well, it certainly seems that all the major religions have been contaminated to varying degrees in that sense.

CG: MmHm (nod)

DW: I guess I'm also trying to find out... there's people out there, scholars that have looked at something like feminism and said, “well Gloria Steinem was financed by the cabal and women are now getting up to be about 40 years old, and realizing wow, I've spent my whole life chasing things that men

want, now I want to have a child and it's too late". Do you think that they are deliberately doing things like this, to try and drive men and women apart since that's the basis of family?

CG: Well, they are constantly socially engineering, and to a degree, yes. To one degree - women were repressed for so long, but to another degree, they take movements, like the women wanting to be equal and anything positive they see, they move in, infiltrate and twist.

DW: Right.

CG: So, I see the women's movement to become equal with men after all the millennium of repression as a good thing, but there has been infiltration and twisting that has gone on that has hurt the cause and has caused schisms in our society.

DW: You said before that there are 22 genetic programs that we've been run with, consciousness alterations, that kind of thing. Some of these do appear to be engineering us to be more easily controlled.

CG: Right.

DW: Do you have any specific examples?

CG: These are social programs, these are genetic programs and these are spiritual programs. These spiritual programs also include them incarnating in human bodies. They are a part of this grand experiment as well. They are very much a part of this grand experiment. They are not just custodians creating and manipulating these experiments. They are very much vested in these experiments. But, there is very strong evidence that I was shown in these smart-glass pads, that they created and manipulated our genes to create a "God gene" where we have a genetic, a very genetically-driven need to worship and follow a leader and to worship a higher being. And this was done to make us a little bit more controllable. These 22 programs, they are running parallel together, but some of them "step" on each other. Some of these programs want us to become more spiritually enlightened and grow and then some of the programs want to keep us "down" and keep us spiritually ignorant and ignorant of our co-creative consciousness.

DW: Why would worshipping a higher being be a bad thing? Most people would think that's a good thing?

CG: It's a good thing, but it's bad when these beings step in as that higher-being to be worshiped, they come in as trickster gods. Not only are these ET's doing it, but for a long, long time, a lot of these break-away ancient Earth civilizations have also been coming to the surface and pretending to be gods.

DW: What seems with the rainbow body training, that you're not really worshiping a divine being, you are becoming awareness. All the stuff I have read about it says, you recognize the nature of existence as emptiness that is aware and that you become that empty awareness. That seems different than worshiping something.

CG: It is. And one of the things that I was told by these higher-density beings, is that we are all one. And this goes along with something I used to say as a child that would upset my parents, who were very conservative, especially my Mom. I would say: "I used to be you. You used to be me. I used to be Grandpa, Grandpa used to be me." And they would say, "that doesn't make any sense scientifically. In time, we're all existing all at the same time, how could you be me, and I used to be you?" I would say: "time doesn't matter; only the experience matters." And they would be like "What?" I am like five/six years old when I am saying these weird things. And, as it turns out, this is what these higher-density beings are saying - that time is an illusion, we are all fragmented but we're all one.

DW: Why do you think in the (book) A Course in Miracles, which is similar to the Law of One, that one of their core teachings would be: forgiveness collapses time?

CG: I don't know. When I hear "forgiveness of yourself and forgiveness of others stops the wheel of karma", that tells me that it ends a cycle somehow. And time to us may seem to be cyclical, maybe there is a parallel there.

DW: We talked about the idea that "forgiveness collapses time" and "in forgiveness lies the stopping of the wheel of karma" - are the same statement.

CG: Yes.

DW: That time is karma. That the experience of duration, the experience of being in this universe, is in and of itself a participation in a fragmented soul. And that the more you can forgive those around you, the more that your soul is reintegrating - hence stopping time, collapsing time and stopping the wheel of karma.

CG: When you are forgiving others, you are forgiving yourself. A lot of times, if you have done something wrong to someone else, the hardest thing to do is to forgive yourself. Forgiving yourself for doing something horrible - and trust me on this, I know - forgiving yourself is the most difficult of the equation. Forgiving others is very altruistic and freeing thing to do for yourself spiritually. When you forgive someone else, spiritually it is very freeing. But to be able to forgive yourself – that is a very difficult pill to swallow. It's a very difficult thing to dig deeply in to and shine a light on.

DW: Did you encounter any information on your own, in the program, suggesting that the rainbow-body phenomenon is real, that this could happen to a human being? That they could turn into some kind of light being?

CG: There was information that I saw, that I didn't pay much attention to because it was not a part of what I was interested in at the time - about people in the east ascending.

DW: Hmm, that was in there?

CG: That was in there, but I really didn't pay that much attention to it at the time. Of course, my interests have changed now, and that's something I'd pay a lot more attention to, but I do not remember reading anything about a “rainbow body” or seeing anything about a “rainbow body”.

DW: Did you ever encounter beings that may be more like that kind of a state, than more of a biological state?

CG: Other than the sphere-beings, I have not.

DW: Is it possible though, that we could go through a transformation at this time, where our abilities would have a rather sudden and dramatic improvement?

CG: I believe that once we become a transitional civilization, transitioning into 4th density, depending on each of us, where we are in our “walk”, we will begin to awaken - abilities will begin to awaken in us. And those who are more advanced will have higher abilities. Those who are lower-advanced will witness those with higher abilities..more advanced and developed higher-abilities and that will “boost” them, because they'll know it's possible. But I haven't seen any “hard” evidence on how that will occur. If it will be a sudden change or a gradual change. But I feel, personally I feel it's going to depend on each individual's personal development and where they are in their “path”.

DW: Well it's really interesting that before these Tibetan monks would actually reach rainbow body, they were already able to do things like the running, where you would run and step one foot at a time and shoot 30 feet high, 200/300 feet through the air. That's called “lung gom pa”. “Lung gom” is the actual exercise, “lung gom pa” is a person who can do that. They would be able to push their hand into a rock and make a handprint. Or push their foot into stone and make a footprint. So this suggests that even before “rainbow body” is attained that a much grander ability to control our reality and to impact physical matter is taking place.

CG: And that's probably where most people will go before they come anywhere close to be “rainbow bodies”, in my opinion.

DW: Alright, well that's all the time we have for, in this episode of [Cosmic Disclosure](#) – because you need to know the truth. We have much more fascinating information coming your way next time here. I'm your host [David Wilcock](#) and I thank you for watching.

[Cosmic Disclosure: Portals: Cosmic Web](#)

Season 1, Episode 12

[David Wilcock](#): Okay. Welcome to another episode of [Cosmic Disclosure](#). I'm here with a remarkable insider, **Corey Goode**, who is helping me to verify information that I've collected from a variety of insiders who have worked in highly classified programs over the years. And there has always been this little something where actually it turned out to be a big something where these people knew more than they wanted to tell me. I don't know if it was secrecy or fear or exactly what held them back, but you could just never get all the answers that you were really looking for. And it was so frustrating. With **Corey**, there is now an Alliance within this Secret Space Program (SSP) that wants us to have the truth, that wants to reveal their technology to us here on Earth and has specifically asked him to work with me, to come forward and to bring you the information that can help us to understand what's really been going on this whole time completely outside what almost anybody knew – even the people who were the most dedicated UFO researchers in this field. In this episode we're going to be talking specifically about portals and I'm going to throw some things at **Corey** that I've heard from other insiders and see

how our data lines up. I'm not putting any words in his mouth, but because I have collected a lot of stuff on this, I want to see how all of these threads intertwine. So, **Corey**, welcome back to the show.

Corey Goode: Thank you.

DW: I want to mention, first of all, working with the insider, Henry Deacon, and who I spoke with extensively - at least 80 hours of very in depth insider-type conversation – one of the things he told me which can help start this off is he said that there are ancient stargates or portal systems as well as modern portal systems. I'm wondering if you're familiar with that delineation?

CG: Yes.

DW: Okay. Before I go blabbing on about what I already know, you're the focus of this show. Can you explain for us the difference between an ancient portal and a modern portal in terms of what it's like, what does it do, how do they function, etc.?

CG: There are the natural portal systems that are a part of the known universe. We call it the Cosmic Web.

DW: Okay.

CG: And the ancient portal systems and the current era portal systems use the, or exploit, these natural Cosmic Web portal system to travel from point to point. The ancient portal systems... and there are several ancient portal systems that are left behind by several ancient groups that have been found on Earth. They vary in their sophistication. Some of them do very short point-to-point jumps to reach... Let's say you want to reach a planet or solar system that is in... They call them 'hops'. If there's, let's say 10 solar systems between where you want to go, then you may have to make three or four hops to get to that desired destination.

DW: This is in the ancient system?

CG: In the ancient system. That's also in the beginning of our current era system - how it worked as well as we were developing it.

DW: Could you just briefly explain for us what you would experience in a hop? Do you have to walk from one place to another once you get there or are you in a craft? How would this work?

CG: Well you could travel there in a craft or walk into one of the bubbles that I was telling you about before. Or you could drive into one.

DW: So the bubble is at the beginning of your journey when you're on Earth. How does the hopping take place? Do you land on a planet or do you land in space? I'm not really understanding the hop.

CG: The ancient systems . . . these are physical, ancient physical devices. And there's another ancient physical device just like in the show Stargate that are spread out across many solar systems.

DW: And when you say, 'Just like Stargate', you mean it's shaped like a ring?

CG: There have been some that look very similar – shaped like a ring, but the one that I saw was – what do they call them 'ziggurats' or they look . . .

DW: Like a step pyramid?

CG: . . . like a step pyramid. They come up three different directions and like a step going . . . in steps up in a pyramid shape.

DW: Three different directions like a triangle?

CG: I mean four different directions. (Okay.) And then the portal would open at the top (Wow!) and it was flat on top.

DW: And would it have stairs going up.

CG: Stairs going up to the flat area.

DW: Would this be an Earth-like place where you've got trees, grass and blue sky and clouds?

CG: These have been . . . Usually they've had to . . . These have been dug up. They were buried.

DW: On other planets?

CG: Yeah, well they've been buried here.

DW: Oh. They've been buried on Earth.

CG: Yeah. (**DW:** Okay.) They've been buried here. Wars have been fought over them. Finding them and knowing how to use them is a totally different thing. They worked on a - just like in the TV show

Stargate – they worked on an addressing system. It was much like the Mac address or the IP address on computer systems.

DW: That's exactly what my contact, Daniel, had said. In fact, he gave me the complete numerical address of the Earth as a . . . There was a series of single digits – three single digits - that could be anywhere between 1 and 9. Then there's a series of three digits that are between 1 and 99. And then the last number can be between 1 and 999 depending on what you need it for.

CG: Um, okay.

DW: And I've never leaked the whole sequence, but I have leaked that Earth's number apparently was 606 and that Mars was 605. That's the last three digits of the address.

CG: Okay. And I didn't know that. (Okay.) But just for those who are out there, a Mac address is . . . in a computer network is a machine's hardware address. And an IP address is the Internet Protocol address for when you're connected to the Internet. There's four octets that identify a subnet mask and then your network and then your computer address. So it's kind of like a large network.

DW: Now, Daniel had told me that almost any number you dial in is going to take you somewhere, because there's a great amount of . . . Like all the addresses are used and he had said that there's some kind of ancient race that comes along and puts one of these ancient gates on a planet and that the planet has one central gate. And that when you gate into that particular number address, it will route you to that particular stargate on that planet. And it seems like these . . . the beings that do this will put a stargate on a planet once it starts to have intelligent life so that they can eventually find it and be able to travel. Does that line up with anything that you heard?

CG: I heard that there were two gates and that, like I said, there were several different ages of these ancient gates going all the way back to the ancient builder race.

DW: That makes sense because when you described the ancient builder race before, you said that they had stone chairs or stone sarcophagi or stone altars or stone slabs, which consistently have very advanced time and space distortion and warping capability and that they were very sought after by the ETs in our solar system because of that.

CG: And there were other gate systems that have been found on the Earth that have been much younger and look differently, but pretty much were reverse engineered or use the same technology of addressing as the most ancient gate travel.

DW: So these addresses, I was told . . .

CG: Now you said, “Any number”. Any random number you put in?

DW: Well, if you dial in . . . I don't know how much farther it goes up above 606.

CG: I'm sure it works a lot like a . . . Like with IP addresses, you have a subnet mask, which identifies a network, which might identify galaxy, solar system and then planet within the solar system.

DW: He said it was something like that except that there's sort of a three dimensional sacred geometry, which I assume is the dodecahedron shape is used to bust out areas into quadrants that are in units of 10.

CG: And that matches for . . . before we were able to start really understanding how to use a lot of these gates, we had to have a hyper-dimensional or multi- . . . I think it was a hyper-dimensional mathematics model handed to us by an ET group.

DW: Right. So yeah, basically you have these step-down versions of these quadrants of 10. So if the first digit is let's say 5, that means you're in the 5th quadrant of that 10-unit section, and then the next one you're going to narrow it down in that region by another factor of 10, etc., etc.

CG: It works very similar to like a computer network (Right.) or an Internet.

DW: The other thing that he said was that there are apparently hyper-advanced angelic or ET groups monitoring this system so that if a given planet of people graduate or ascend, or otherwise, leave their planet, that that gate address is then recycled and given to another group where that planet is now evolving. So, in other words, let's say, number 540 is used up – that planet evolves or graduates – 540 will now be relocated somewhere else and given to a new group. So there is some kind of intelligence, he said, that's behind the . . . when you get to the final three-digit number.

CG: That's new to me.

DW: Okay. The insider Jacob, who I spoke to, said that even in ancient times it was very highly kept secret by the Celts and Druids and stuff like this, but that they had a technology of two permanent

magnets that were on something like a tuning fork kind of thing, and that the magnets would pull together harder or push away more when you go near a portal . . . that just walking through the woods and that they hold this out and that's how they would try to find them. Did you ever encounter anything like that?

CG: I've heard about that same instrument and also that same instrument being used for mapping out the ley lines and certain energetic points on the Earth.

DW: Wow. Do you know enough about it that we could maybe try to replicate it? Is there a specific type of magnet that's required or do you have any specifics on it?

CG: No. I just basically heard what you've described.

DW: Well, that's mind-blowing, because we've never talked about that before. So clearly, there's some sort of magnetic flux in a portal area.

CG: Oh, yeah. NASA recently released that our sun has a basically a portal or a magnetic filament connection to every planet in our solar system, and anything that has enough mass to cause a gravitational pull or a torsion in our space-time is going to create a magnetic and gravitational relationship with the host sun. And these filaments that they are just now releasing – these filaments are the portals.

DW: Right.

CG: And they are strong electromagnetic filaments.

DW: But if people don't include the torsion component, they're not going to understand how this works. (Right.) So it's an electromagnetic tube that also has a strong torsion field and would act like a traversable wormhole.

CG: Right. And it's happening within the torsion field of each solar system. The galaxy is a giant torsion field. All of the stars are constantly moving around the center of the galaxy and stars closer in are moving at a slightly different speed. And the magnetic relationships are always changing. These filament relationships are always changing between each star.

DW: Right. It's just like electricity. Electricity takes the path of least resistance. And if you want to travel to a star that's on the other side of the center of the galaxy, you have to wait or calculate just the

right time to travel, because if you don't, if you begin your travel and this star has just changed its position and the electrical field, or the electrical connection, changes to another star – the path of least resistance – you're going to find yourself in a different sol system.

DW: Like a short circuit.

CG: It's the path of least resistance. It changes. It's a very complicated. And the further you go, the more complicated the calculation is.

DW: So we were starting out by talking about ancient vs. modern portal technology. I'll just toss in something else that I heard, and I want to hear if this goes with what you're saying. Henry Deacon had told me that the ancient system involves a sort of a ride or a subjective experience that can be extremely jarring. You can come out the other side at best vomiting and very disoriented and at worst completely mentally insane and irreversibly damaged by it. And he had said that people would have to study and really get advanced in their consciousness capability to be able to use these portals safely.

CG: And also there was a chemical that was used – shots. People were given shots to help them with these effects. And this was corrected . . . they learned how to use these ancient gates more efficiently when they learned how to make the calculations better. So this became less of a problem. But in the beginning, this kind of travel from point-to-point within our solar system was bad enough, but traveling from star to star was really not a good idea for a person. Even after we had developed it to a point where we were able to travel from planet to planet in our solar system, and negate the physical effects, it took awhile for them to get the calculations right and to fine tune traveling these ancient portal systems to travel to other star systems without these major ill effects.

DW: In the aftermath of the Philadelphia Experiment, there are reports of a bar fight breaking out in Norfolk, Virginia, where these guys were fighting each other and punching each other and when they became angry, (**DW:** Going out of phase.) they became invisible, and that they had these little belt packs that would apparently keep that from happening. Is that true and why would that happen if that is true?

CG: The Philadelphia Experiment . . . that was a very irresponsible experiment. From what I saw, they did not do a whole lot of non-human testing before that, and this did not involve using a lot . . . involve using torsion fields. This was heavy electromagnetic fields used in a pulse way (**DW:** Pulsing.), pulsing way that caused them to change the phase. I can't remember the terminology they used, but they

measured what our natural state of matter phase is and they figured out you could change that with, or at least interfere with it, with high electromagnetic fields.

DW: The insider, Jacob, had told me that folks like the Draco are only slightly out of phase with our own reality, and as sensational as this sounds, there were Draco ships landing on the White House lawn every day and entering into an underground facility below the White House where they are having planning meetings and things like this. Did you ever hear of anything like that?

CG: I know that a lot of the high advanced cloaking brings the vessels and the beings slightly out of phase, and the Draco also have all kinds of strange abilities. A lot of people that see – what do they call them - 'shadow people' that scare them and they feel like that they are being fed off energetically by these shadow people. These are these Draco beings astrally projecting into the room (**DW:** Oh, wow!) to feed off of them. Yeah, these Draco have some extremely high technology.

DW: So the modern gate system you said has perfected the side effects that happened in the Philadelphia Experiment?

CG: Yes. Not only that, they can do . . . they don't have to have . . . always have to have a point-to-point . . . they don't have to have a device here and a device there. It's almost . . . They're able to pull a craft over an object and portal it onto the craft – almost like Star Trek beaming up – and it's still using the same portal-type of technology, but very advanced.

DW: Would that involve maybe some triangulation where you've got three beams that triangulate on a particular coordinate point and then you pull the portal from that point back to the origin?

CG: Right. It's creating a portal out at a further point and portaling that back to your home location. No, but they've perfected portal. The modern portals are extremely advanced.

DW: Can you portal yourself directly into one of these underground facilities as well as the surface of a planet? Is there any interference when you go below the surface of a planet.

CG: No. (**DW:** Okay.) No, you can portal straight underground to underground of another planet of another star system

DW: So from what I gather that you were saying before, there are probably oodles of ancient builder-race-working portals to be found in these underground caverns.

CG: Portals and all kinds of other crazy technology.

DW: Do you think that if we get the [Cosmic Disclosure](#) that our title is about - this Space Program finally revealing the truth to humanity – do you think that people will be able to have access to portal technology soon in that post-Disclosure society?

CG: I don't know how soon. I get asked this question a lot. 'How soon will I get to talk to an ET? How soon will I get to take a tour of the solar system? How soon will I get to portal to Mars? How soon . . . ' You know, this is going to be a process. A lot of the technologies we're going to have access to in the beginning is going to be to enhance our lives down here. (**DW:** Okay.) Then there's still a lot of mess out there to clean up. So this is not going to be an overnight fix. It's going to take awhile to clean up this big mess that we've created over a long period of time. Now, just the fact that this portal system - this Cosmic Web - exists, lets us know that once we develop to a certain point to where we're not considered a menace to ourselves and to others, that once we're considered a transitional civilization into 4th density and to being more loving and more positive and we're more of one mind and working together, all of these end points that these portals connect to, all of these different beings out there, these are basically long lost cosmic family that we're going to start getting to meet at some point - we're going to start learning about. Surely at some point, they're going to start coming to visit us in these portals and we'll be invited to visit them. And there's probably going to be all kinds of nice foreign exchange student situations. And it's going to be very interesting to see how things develop. I don't have a crystal ball, but . . .

DW: In terms of the technology that you're already familiar with, will we be able to have, eventually, a civilization where everybody could have a working portal in their home where they could make very large jumps without having to go to any type of transfer station or hop station? Or would it be more of something where you might have a local transport that gets you to a hub where larger portal systems are used? Would it be too entangled if everybody has a personal one that can go the distance?

CG: It sounds kind of chaotic, doesn't it? (It does.) I mean, it would be nice to be able to portal to the mall or whatever, but when you have 7 billion people that all of a sudden have a new toy and want to portal all over the galaxy, that . . . I don't know. I don't know if I see that happening immediately. I think that we'll definitely be able to portal to Cancun or the Cayman Islands and that kind of thing in the beginning.

DW: Well, I'm also wondering if there might be . . . To simplify matters, the craft that you're describing, it seems like they would travel so fast that portals might be reserved for things that are off-planet and that being on the planet . . . You might have portal stations like subways or airlines, but that people might end up with their own private craft that they could use to travel wherever they wanted to go so fast that it really doesn't make a difference at that point whether you have a portal or a craft.

CG: Right. And like I stated earlier, many of these ET races they use very large craft and they portal through the Cosmic Web all over our galaxy and to other galaxies. And our galaxy is just a little bitty spot and all of the other galaxies and our local galaxy cluster and then beyond, they've already mapped out with the Hubble Telescope. They've taken pictures back of billions of years ago the energetic connections between all of these galaxies and these now are filaments that form the Cosmic Web. You've heard people say that everything in time and space is connected. That's very much the truth. It's all . . . Everything is connected and it's just . . . I mean just a short little hop skip and a jump away.

DW: We only have a couple of minutes left, but you did make me think of something that I've featured in my books, I think, all the way back to 2001. Two sets of names – one is Battaner and Florido, and the other one is Einasto. And they are researchers primarily out of Spain who mapped out these super clusters of galaxies and showed that they were all in geometric matrices. And they called it the egg-carton universe, because it looks like an egg-carton. But those do appear to be . . . The sacred geometry appears to be a function of vibration. When you vibrate a fluid, you get the same shapes. And these appear to actually be filaments that are connecting these galaxies together just like what you're saying.

CG: Yeah. And what I've been shown by these ET races, our entire universe is a giant torsion field – just like a galaxy and you see a torsion field. That's why some stars are travel this way. Some are traveling that way. And some are zipping around. You know Hubble Telescope has captured some galaxies that seem to be traveling away from us faster than the speed of light. They can't explain it. They are trying to explain it. Our universe, I'm being told, is a giant almost like a bubble, a torsion field. Everything in it is connected via filaments that I'm being told is called the Cosmic Web.

DW: Well thank you, **Corey**. In the next episode, I think this is a really good time for us to get into time, and I want to talk to him about what other insiders have described to me as layered time – the idea of how time can stack on itself, the three dimensionality of time. And we're going to see time and portals interfacing and really try to get more of an understanding of how this new physics applies to

this bizarre world of the Secret Space Program. That's coming up next time on [Cosmic Disclosure](#), because you need to know. I'm [David Wilcock](#) and I thank you for watching.

[Cosmic Disclosure: Portals Navigating Time](#)

Season 1, Episode 13

DW: Hello, and welcome to [Cosmic Disclosure](#). I'm your host, [David Wilcock](#), and we are having in-depth discussions with a secret space program insider named **Corey Goode**. There's a lot of laughter around this subject, a lot of people who think that this is something they can ridicule on the internet. But if you've been watching our show, I think it will become clear to you that we are not dealing with something that is easily dismissed. Granted, we don't have all the documents yet. We don't have the degree of proof that some people would want. But when you start to talk to as many different insiders as I have, who have cosmic top-secret clearance and above-- and that means 35 levels above the need-to-know basis for the President of the United States of America-- these people have come forward as whistleblowers, and they all start sharing with me, because I've sought them out, very specific things. And it all interrelates. It becomes actually more of a stretch to think that they could all be lying from a unified body of lies than that they're actually describing something that's true. In this episode, we're going to go into the discussion of time, and how our physics will need to be altered based on what we have encountered. So without further ado, **Corey**, thank you for being here. Welcome to the show.

CG: Thank you.

DW: All right. Now let's get right into some hard insider data. One of the things that fascinated people the most about my insider testimony when it first started coming out online was what I shared from this insider named Daniel who claims to have worked on what most people call the Montauk Project, but what he called Phoenix III. What he said was that our military industrial complex had procured a seat from a crashed extraterrestrial disk and that the seat itself acted as a consciousness interface. And someone could sit in the seat, put their head back, and then there were 22 base waveforms that would be the energetic field of the person that they would measure. And you would go to what they called the quiet point, a stillness in your mind. Then they would have to zero out the chair, which means once

these 22 sine waves stop jiggling and you can get them to stay still, then they would individually tweak the knobs on each one and make them flat lines. And at that point, so he was told and so he experienced, a lot of weird things could happen. For example, you could think about an object. And the energy that this chair would harness that they had to create a very specific frequency with these huge transformers, you could manifest that object in the room. And he also said that if you thought about a particular place that this sort of shimmery mirage thing would appear, and you would see that place through the mirage. And they could actually send people through that, and they would travel there. He also said that this was standard design for seats in UFO-type craft and that the pilot would think about where they want to go, and it just pops open a hole and they fly through, and they go. So before we get into all the deeper stuff that he said, anything that I've just told you, does that line up with stuff that you've heard?

CG: Mm-hmm.

DW: OK. Could you give some specifics on that, then?

CG: Well the chair, the chairs very much. So the consciousness interface with the chairs. There were chairs that we were put in in the MILAB Project when I was a child that the intuitive empaths were put in, that they would put us in and-- you mentioned the 22 waves that they would try to get us to go into-- in a negative way, we were being trained to be enabled on command to go into different states of consciousness that were measurable. And--

DW: How is that negative? I'm not sure I understand.

CG: Negative reinforcement ways.

DW: Oh, like electroshock torture kind of stuff?

CG: Electro-- yeah. They were putting us in these chairs that were ET chairs from craft. And they were trying to see which of us could change the wave, certain waves, in it most proficiently.

DW: Really?

CG: Yeah. I find that very interesting. Now we weren't manifesting things in the room or looking at other locations and that kind of stuff. But they were using that device that was a chair out of an ET craft to have us-- to test us to see which of us, through interfacing with this chair, could change certain waves on command.

DW: He was also brought into some sort of training for what they called apparently the Psi Corps, like a corps of the military that was psychic-based. And one of the basic things that they wanted him to learn to do was to go to what they called the quiet point in yourself. Did you ever hear that term?

CG: Yeah.

DW: What was your understanding of the quiet point training? What is supposed to be done? What's the objective?

CG: When you reach-- I think it's deep theta. That is when you're least conscious of your body, least conscious of your surroundings, and more in contact with I guess what we call our higher self, and more in a higher consciousness state. And all other thoughts-- no other thoughts enter your mind. You don't think about I'm cold, you know, what am I going to eat later, my nose itches, this seat's uncomfortable, this texture of this pair of pants feels weird on my leg. I mean you're having no thought. And people say having no thoughts is impossible, getting your-- training yourself to be at a point of being conscious but having no thought is where they wanted you to go. That's the best way I can describe it.

DW: Pursuant to my original question, did you also encounter information suggesting that the seat within a craft has an interfacing capability that would allow you to will open a portal that could take you to another space or even time?

CG: Yes. That's-- later on, I found out that that was how these craft operated. It was completely consciousness-driven. And most of these beings wore a headband, sat in these craft, and either wore a headband or sat with their hands on a panel and just like higher-density beings thought of a place they wanted to go, and the craft would phase out of this location and phase in to that location.

DW: Would this travel sort of automatically-- hop through the cosmic web that you were describing?

CG: No. This is more of not only-- we've talked about how everything is vibration. Everything has a vibrational signature. Every solar system, every planet, every location of a planet, has its own vibrational signature. And consciously, if you think of that place and that place's vibrational signature, and you can change your entire vibrational signature of what you're sitting in and what you are to match that vibrational signature. The universe is holographic, basically. Then you phase out and re-phase in at that location.

DW: Now in--

CG: Does that make sense?

DW: Yeah. In the Carlos Castaneda books, Don Juan, the original shaman, apparently there is a real guy named Cachora, and he's still around. Cachora said-- and this does appear to be real-- that some of these shamans can learn to teleport themselves. And the way they do it is if you can have an out of body astral travel type experience and then consolidate a particular location strongly enough where you keep it completely stable, and it doesn't shift, and it doesn't flux, that once you can really hold and consolidate that new location consciousness-wise, that you actually jump there.

CG: Yeah.

DW: So it does work that way?

CG: That's how a lot of-- some beings travel that way.

DW: Hmm.

CG: Yeah. They send their-- we call it astral projecting. Or they send their consciousness there. They see the surroundings. They recon where they're proposing to go. They gauge the vibration of that area. And then they report that vibration back to their conscious body, and the conscious body changes its vibration and phases out of where it was and comes to the location of where their consciousness is.

DW: So is the chair within a craft sort of a technological assist to that process that enhances your natural ability?

CG: Yes. Some of these ETs have found a way to cheat, to be able to do what some of the more ascended or higher-density beings do to travel and get around.

DW: So the chair sort of enhances their own native ability.

CG: Right. Consciousness.

DW: Well I want to get to the core of why I brought this all up, which is the time stuff. Daniel had direct knowledge of people in the Phoenix III program. There was one guy in particular who was a little crazy, more than a little, said-- because they figured out that these portals that they were creating,

first they thought it was only space travel, then they realized that you could go to different points in time just by thinking about where you want to go.

So this crazy guy, he goes and he says, I'm going to kill my father. Because they figure out they can go back in time.

CG: Yep.

DW: And have you heard about this particular story?

CG: I've heard of this paradox, yes.

DW: Okay. So instead of me talking, why don't you describe what would happen, or what are some of the historical cases of people trying to do weird stuff like this, and what happened.

CG: From what I read on the glass pad, one of the major reasons that they put buffers on this temporal technology is that some of this time travel experiment and technology got extremely out of hand. People were traveling back in time, deciding that if they killed one person, it would change the time-line. These people would end up coming back and being on the time-line they created. And it was creating all these schisms and split time-lines. And then they were sending people to go back and prevent it and fix it, and it was causing even more and more problems, and more and more timeline splits to where there were all kinds of fragmentations, and it was just way out of hand. And they started getting visitations from very advanced ET groups saying enough. You guys have got to stop. And it was also explained that time is very much an illusion, that just as they were using consciousness, that was a key component, they were using consciousness in that chair to manifest things, which is something that we do with our mass consciousness every day. We're manifesting our reality.

DW: Right.

CG: This ability to use this device, to use their consciousness, to go back to this time-line, this time-line that these people are going back to, it was based on this one person's consciousness, and the polarity of that person, how positive they were and how negative they were. And the same thing with the people that were traveling into the future. People that were traveling into the future, if they were of a negative polarity cabal group, they were traveling into the future and seeing oh, there was this huge cataclysm. The rotation of the Earth changed on its axis. 90% of the earth died. All these horrible things happened. And then they would come back and report. And more positive people would do time travel,

and they would see a glorious future. Well if the technology is sound and you have multiple people of different, I guess, positive or negative polarities that are doing these time travels, what does that tell you about time?

DW: That's an interesting point.

CG: The ETs told us to stop-- back then-- to stop trying to repair all these schisms and time-line problems because that just like space, time is elastic. And that just like if you have a highly-- just like a torsion field, you twist space. You remove the torsion field, space is going to snap right back. You screw around with time, time is going to repair itself. It's going to snap back.

And the scientists had a hard time believing that. They could not believe that time was an illusion and was something that was going to snap back and repair itself, and that it was-- time was a major component of consciousness.

DW: It would appear that if we go back in time in our own history, there's the legend of fairy rings, where you have a circle which appears to be a crop circle, and people could walk into these and they'd meet people that looked different-- elves, gnomes, leprechauns, dwarfs, fairies-- and one of the legends was that if you go into a fairy ring, you have to go out the same way that you went in, or else you will time travel. What are these fairy rings, and how does this relate to what we've been talking about? Did you hear anything about them?

CG: I did not hear anything about them. But it sounds very similar to these federation meetings happen inside of a temporal anomaly or a temporal bubble. And just like you described, you come in-- you have to leave the same trajectory you come in.

DW: Oh, really.

CG: So these fairy rings may have been some sort of ET temporal bubble that they had there to observe something going on. And if a person walked into it and got stuck in this temporal bubble, that if they didn't leave out the same way they came in, they would get stuck in for hundreds of years. And to them, it might've been minutes, like the Rip Van Winkle kind of thing.

DW: One of things that Henry Deacon shared with me was that time is actually sloppy, that time hiccups and makes jumps, but that we, somehow with our energetic body, glue together the glitches in time. We have a psychological buffer that makes it appear to have continuity, but that there are, I guess,

phase relationships between our solar system and other stars, or planetary conjunctions or things like this, that actually are causing glitches that we're apparently not at a level yet where we can detect them.

CG: That's somewhat true.

DW: Really.

CG: Yeah. And until we learn to-- I mean time really is a complete illusion. For us stuck in this really third density way of thinking and consciousness, we're not going to really be able to understand it. But time speeds up and slows down all the time, because of-- the people that are out there talking about-- was it Nassim?

DW: Nassim Hamein.

CG: Hamein. Some of his information is just great.

DW: Well viewers on this network can watch Nassim's video "Black Whole", which was produced by Gaiam--

CG: Great, that's great.

DW: And there's also interviews with him on here.

CG: That's great.

DW: Yeah.

CG: The electro-plasmic universe and the torsion universe, these are the models that the secret space program are working off of. All of these other sciences that people think are cutting-edge that are down here that people are working on are going to be thrown out the window. All of these PhDs are going to have to go back to school when this information is released.

The true sciences that are being suppressed from the people down here are-- I mean the mathematics to them is a whole-- there's a whole new mathematics, too. We're working on a very archaic mathematics, physics, and-- but once we learn to understand how all these things work, we'll understand things like why time is always speeding up and slowing down. And it has to do with the torsion effects of the galaxies on each other, on our solar system, and on our minds, and how we perceive it.

DW: Well let me throw this at you. We were talking about the Montauk chair. And recently **Pete** Peterson gave me some very fascinating information where he said that on our back, right in the shoulder blade, there's a dimple there, and that all the nerves of our bodies cross over in this one little spot, and that this appears to be some type of divine intelligence design. And he said that these are called ports, and that many different extraterrestrials have chairs that have nubs that you have to kind of sit into, and the nub goes right into that little spot in your shoulder-- you're nodding your head a lot.

CG: Yeah. We use them too. You can download a lot of information through those.

DW: That's why I brought this up because you said these scientists are going to have to go back to school. **Pete** had said that, for example, a vision system can be done through these ports, that a lot of these fighter jets that we're using now don't have windows, that you can see through the ports, and you see in your mind, it has actual telescopic vision. And he said that you can actually download information right into your mind.

CG: Mm-hmm.

DW: Have you encountered anything like that?

CG: I've used the download function of that.

DW: Through the ports in your shoulder blades?

CG: Through the dimples-- yeah.

DW: Wow.

CG: Yeah. They've-- yeah. The download function of information.

DW: See that's so weird, right? How could-- this kind of stuff just blows my mind.

CG: And also there's so many nerve endings in your fingers and in your hands. That's why it hurts so much when you hurt your fingers compared to if you hurt yourself here.

DW: Yeah.

CG: A lot of the devices that are neuro interface devices have like a copper and kind of like a stainless steel plate that are shaped like a hand that you put your hands on. Or they have gloves that you slide on

that have strips and metal inside them. And that is used for you to neuro- or bio-electrically interface with craft and other devices as well.

DW: Did you hear on your own, independently, that these ports in our shoulder blades have all the nerves of the body crossing through them, that there's like a big intersection there?

CG: I wasn't told that. I was-- this was mainly when I was in the MILAB era. We were sat in chairs. Uncomfortable-- two uncomfortable little nipples, kind of things poked us in the back. And we leaned back, and we felt an electrical sensation come through the little bumps that we were leaning on. And it would download information to us to teach us information.

DW: And that is an example of something that genuinely happened here. We'd never talked about this before. It's a very obscure, specific detail that you've encountered on your own.

CG: And I was told that one-- back then they said that one day this was how everyone will be educated.

DW: Right.

CG: Yeah.

DW: Well we're going to be talking a lot more about time. There's a lot of other things I want to ask him because this is a vast subject. Time travel, time jumps, it's something that people are really fascinated with. And we also may get into something he's talked with me about before, which is this weird parallel earth. That's all going to be coming up next time on [Cosmic Disclosure](#) because you need the truth. I'm your host, [David Wilcock](#), and I thank you for watching.

[Cosmic Disclosure: Portals Parallel Earth](#)

Season 1, Episode 14

DW: Hello. Welcome to "[Cosmic Disclosure](#)." I'm your host, [David Wilcock](#). And in this episode, where I'm here with **Corey Goode**, our insider's insider from the space program, we are going to be talking about the science of time even further. And I want to start to dialog with him a little bit about

some of the things that I've studied in this very fascinating subject. Because when we start to get into the real world data, things get very interesting. So, **Corey**, welcome to the show.

CG: Thank you.

DW: Let's kick this off by bringing in a data point from a book by a Chinese guy named Paul Dong called "China's Super Psychics." And in this book, he describes working with the Chinese government, where they find these children who have advanced psychic capabilities. One of the experiments that is documented in this book is a human being who had the ability to teleport a small object. And the object would appear to fade out of existence in one location. And it would fade in in another location. So what the Chinese wanted to do was to figure out, OK, what's really going on here? And how does this work? So apparently they put a beeper on the device. And the beeper was set to beep in a certain time sequence at a certain rhythm. What they found was that as the object starts to fade out of existence, the beeps became slower and slower. As if time itself was changing in speed. And then it was just as slow when it shows up on the other side. And then it would speed back up to its normal rate. So is it possible for us to be able to affect time and space as a singularity like that?

CG: Well, we can affect time and space and matter with our consciousness, which is exactly what that person was doing.

DW: Right.

CG: And time and space-- we'd call it space/time, time/space for a reason. So, yeah. That experiment showed how intertwined and related the two are, in my opinion.

DW: Now in Einstein's basic physics model, he does allow for time to shift. But it only can be done within an area that you're accelerating towards the speed of light, like a craft, let's say. We know that in the 1970s, they took molecular clocks and flew them in airplanes. And that they confirmed this Einstein relativistic drag is true.

CG: The atomic clocks?

DW: Right.

CG: Yeah.

DW: The real gems here seem to be that time is locally variable. That you can actually accelerate or decelerate the rate of time in a small area. Now the conventional physicists who are watching the show, the skeptics, are going to say, oh, that's impossible. So is this part of the physics that we're going to have to change?

CG: Definitely. And I know that you're probably familiar with this. But a person doing a certain experiment has an idea of how that experiment should go. And the power of their-- the co-creative ability and power of their consciousness causes an outcome of that experiment.

DW: Right. Absolutely.

CG: Well, if you changed it up a little bit-- time, matter, space are all related. And our consciousness can make changes to matter, to time, and to space. Just as we were talking about how some people, or beings, have been able to change their teleport, change their location, with consciousness-- changing the vibration of their body to match another vibration of another location-- you can also affect time. And as we're learning more and more about how this universe and reality is a hologram, we're learning-- when you really learn it and believe it-- just like in "The Matrix," "there is no spoon"-- then that takes away a lot of restrictions from your consciousness. And there's a lot more you can do with bending time and space and reality.

DW: Why do you think these guys in the Philadelphia experiment allegedly got embedded into the hull of the ship? What was going on there?

CG: Well, the vibrations, the matter of the metal of the ship was in a transitional phase, as was the bodies of the sailors. And they probably were freaking out during this out of phase, this process when things were out of phase, and they moved around. And then when they were brought back into phase, they found themselves now trapped in the metal as it phased back into what we would perceive as solid material.

DW: Have you experienced this phase-out consciousness and matter condition yourself? Did you ever get exposed to that type of a weird boundary condition?

CG: When you're brought through a solid wall, you know that something like that has happened. So, yes. And I've seen technology used-- bracelets that were taken away from extraterrestrials. And the intercept interrogation program that they would-- the extraterrestrials had-- that they would turn on. And they would shake and then phase out as if they were completely invisible and couldn't be touched.

Well, with this technology, it wasn't meant for humans to wear. Humans tested it, and they put it on. And it shook them violently, and they broke their necks.

DW: Oh my gosh. Really?

CG: Yeah. Later on they had developed technology to where these human beings were able to walk through walls. But before they fully developed it, people were exchanging their human residue and the residue of the walls-- there was interchanging going on. To where some of the material from the wall was ending up a part of their body. And part of-- in the walls, the human-- you've heard this?

DW: Oh, absolutely. OK. You're describing something I heard from **Pete** Peterson. In his division of Area 51 when he worked there, they developed a little thing that was the size of a quarter. You hold it in your hand and you push the button-- you pop out of phase. They were trying to figure out how to get through walls. So they'd have these guys hold onto this little thing, take a running jump, jump into the air, jump through the wall, hit the button when you hit the air. They would go through the wall. Then they'd release the button, and they'd pop back in on the other side. The problem that he said was happening-- he didn't say that it was the material of the wall which I certainly believe could happen-- he said people would get sick. And their eventual conclusion was that all the bacteria and the viruses and the natural junk that's in the atmosphere would blend in with our bodies. And normally our lungs filter that stuff out. People would get sick, they'd degenerate very quickly. And so within Peterson's division, that little thing-- they said, we can't use this.

CG: That was back-engineered from what I'm talking about.

DW: Oh, really?

CG: Yeah.

DW: That's fascinating.

CG: They eventually perfected it. They can use this type of technology to walk through walls and stuff now and not have ill effects.

DW: You remember the guy I told you about who's autopsied some 2,000 different types of extraterrestrial bodies. At one point, he was attacked by people who appear to have walked into his house through his wall. And I had no data to back that up until you just said that.

CG: Okay.

DW: So I wasn't sure if he was actually telling the truth, but now there's reason to believe that that part of his story is correct.

CG: No, they absolutely have that ability. You can lock your doors, and lock your windows, and sit there with a loaded pistol. And they can come in and out of phase. That's technology that is available to very high-level black ops groups.

And for that level of technology to be used against you, you have to have-- most likely have done something very stupid or wrong against the program you're in.

DW: Let me ask you the same question I asked Peterson. If you hit this button, and you're out of phase with our reality, why don't you just fall through the floor? How would they get through a wall? Do they have to jump through the wall and hit the button? Or is there some way that they have enough phase in their feet that they can still interface with the ground enough or something?

CG: That's a good question that I don't know the answer to.

DW: Okay. Interesting.

CG: But then again, if you're out of phase, why would gravity pull you down through the floor?

DW: That's a good point.

CG: I don't know. But these guys know. They go out of phase, and they walk on the floor. They walk through spacecraft. And they can walk through the walls as if the walls weren't there.

DW: One of the really interesting things that we have spoken about before is this parallel earth. Now instead of me just blabbing away on it because we want to get you talking as much as we can, what is the parallel earth?

CG: This is something that I mentioned to you. And as I said, I read a little bit about it. This is something that is very sensitive information that I wasn't given-- I wasn't privy to a whole lot of information about. But it piqued your interest. I'm not sure, is it because you had heard something about it before or what? But--

DW: I remember how we got into the discussion. And the original way that we got into the discussion was I asked you if you time travel back into the past, and you see yourself-- if you get too close to yourself, will you explode? And you said no, which surprised me. Because other insiders I'd spoken to-- at least one-- thought that you would actually get some kind of electrical fire, some kind of interference feedback with yourself, and you'd blow up. Or just poof! But you're saying that doesn't happen?

CG: Right.

DW: So it is possible for people to portal back in time, and you can get right up to yourself, and nothing happens?

CG: Right.

DW: But then you said something was different with this parallel earth thing?

CG: Yes. And the type of portal.

DW: Oh.

CG: There was a highly talked about and rumored type of portal room that they called the Xerox room, that brought you to a parallel reality, a parallel earth. And it was not something that people wanted to go through. I certainly would not. In this one, when you're portalled through it, it makes a copy of you, sends a copy of you to this other reality, and destroys the local copy.

DW: Oh my god.

CG: And then there's this other copy of you in this other reality, this other earth.

DW: Well, I've always said I want more than one of myself so I can get more work done. Could you Xerox yourself and not destroy the copy?

CG: That's built into the function.

DW: Huh. Is it like a time paradox or something if you have two copies of yourself?

CG: I don't know.

DW: Okay.

CG: And that might be some of what-- a lot of what people are talking about clones being done. They may be using some sort of this technology to be making carbon copies of their self. Anyway, these people go to a parallel reality universe, to where apparently things have played out very differently. And there were and weren't certain wars. Wars turned out differently. Different people were leaders.

DW: You're saying it's Earth--

CG: It's Earth.

DW: --but there's something different about the history of Earth?

CG: Yes. And there are us's there. And sometimes there are, and sometimes there are not, depending on what had happened. But if you ran into yourself there and touched yourself, there was an annihilation effect.

DW: Really?

CG: Yeah. That was so incredibly bad that it was said that-- they theorize that it could rip the fabric between the two realities or something. I can't remember all the details from the space-- from the glass pad. But I don't have a whole lot of details about that. I wasn't a part of that project. There were some people that were. For some reason, it was considered a very important project. There were some very high-level people involved in it. But the Xerox room was-- that portal device was something that people dreaded. And was not something I would ever have agreed or volunteered to go through.

DW: Where was the Xerox room located?

CG: Well, there's not just one. But the one that I was aware of was in an underground facility somewhere here on Earth. But they have, supposedly have, also one of these devices down at the LOC on one of the lower levels. But I have never gone below, I think, the third or fourth level at the LOC. I've never been given the grand tour that, at recent meetings, some people that have not ever been in the space program-- secret space program-- that have been there for conferences, have been given the grand tour. And I haven't been allowed below the third or fourth floor.

DW: Were some people able to go to this other reality and come back successfully?

CG: Mm-hmm.

DW: Do you get copied again to come back?

CG: Mm-hmm. The process repeats itself.

DW: So now you've destroyed yourself twice?

CG: Yeah.

DW: Was there any lack of continuity in people's memories? Or any anomalies with their minds, as a result of being destroyed and reconstructed from a copy?

CG: Not that was reported, other than the unpleasantness of the process.

DW: What was unpleasant about it? Just the thought? Or was there a sickening feeling?

CG: It was a painful, unpleasant process.

DW: Really?

CG: Yeah.

DW: You feel your death?

CG: I'm just saying what was reported. It was a very unpleasant, painful process.

DW: Oh, wow.

CG: And there are people from that parallel universe reality world traveling here as well.

DW: Right. Could you delineate what are the main differences in the history of this parallel earth compared to ours? Anything that you specifically remember that was different about it?

CG: It's hard to remember it all. I remember World War II turned out differently.

DW: As in, that the Germans won instead of America?

CG: Right. The Axis powers won. At one time I remembered a lot of the details that I read that were in that-- it was a short summary that I was given access to. I wasn't given a lot of information. And I--

DW: Well, the insider that you introduced me to-- who in the beginning you had so many things in common with and so many things that he knew that nobody else knew, whoever you'd met online-- he

said that that earth didn't have Roswell. And had far less interaction with extraterrestrials than we have in ours. Did you ever encounter that information?

CG: I encountered that information, but I can't remember from which source I got it.

DW: But he did say the same thing that you're saying, which is that, in his opinion, it was a very important project. And that we were both helping each other in some way.

CG: Yes.

DW: He said that they had much less of the kind of advanced technology--

CG: Yes.

DW: --than we did. And so we were trying to get them some of that. Do you think that in order to get people to do this, they have to bring in a newbie? Somebody who hasn't heard the scuttlebutt about how horrible it is and how dangerous it is?

CG: No. These people consider this a very important mission, and they're very dedicated to it.

DW: Really?

CG: Yeah.

DW: And one of the key things-- which I think you did say to me before, not in this taping-- was that this parallel earth is not doing too well, as far as war and stuff. It's in a much worse shape in that sense.

CG: Yeah. It's supposedly a really dreary, hopeless place to be.

DW: So almost like a new world order that worked? Like a worldwide fascism kind of thing?

CG: Right.

DW: There are some people in Jenny Randles' book, "Time Storms," she has a whole bunch of stories about natural time slips, she calls them. There's a kid that goes missing. Three days later, he pops up in the garden. And they've searched that area hundreds of times, and there he is. A bubble of light shows up. And modern people would probably say, hey, that's a UFO sighting. And then they get a missing time experience. Oh, well, I lost four hours. So some of those might be UFOs. But some of these could be a natural portal. Would you agree?

CG: Exactly.

DW: Jenny Randles also describes some people going through these time slips, and that there's a piece of furniture in their house that's now different. Or the walls are painted a different color. Or a window has curtains that didn't have curtains. Or that there's a stone path from their front door to the street that wasn't there before. And everybody laughs away at this. So is it possible that if we muck around by accident in a time slip, that the actual reality that we're in could just reconstruct around a slightly different theme like that?

CG: The people that were involved in these type of time experiments-- they were on the lookout for these types of things. They were to report them immediately if they noticed things like that. Like, they would go to hang their toothbrush up in their little toothbrush hanger. And all of a sudden, it's on the other side of the wall, on the other side of the mirror. Weird things like that started happening to the people that were involved in some of these temporal experiments. That's pretty interesting. I hadn't heard of that book. But little things like that-- it's interesting you bring that up. But those were some things that these people were told to keep an eye out for and report immediately if they encountered.

DW: Do you think that these bubbles that people-- and I understand you haven't read the book-- but these bubbles are on the move. And there's cases of a guy smoking a cigarette-- and when people say that a UFO shows up, they say, there's no sound. I don't hear birds. I don't hear the wind. I don't hear anything. Could it be that that lack of sound in these UFO contact experiences is because time has changed, and as the bird is making its cry, it's so slow now that you can't hear it anymore?

CG: No, that is absolutely what's happening. That is absolutely what is happening. That's when UFOs that have landed in people's front yards-- there have been people that have reported people out standing in their front yards, motionless. Cars driving down the streets that just stopped, that are just-- and things like birds in midair, stopped. It is absolutely-- they have found a way. They're manipulating space and time. So absolutely, yes.

DW: Well, I want to thank you for getting into this fascinating discussion with me. We are by no means done with talking about time. We have a whole year worth of half hour episodes to fill up. And there is so much more that I want to talk to you about with this. Because this is a very big subject. And all kinds of interesting stuff coming up in our next episode. And I thank you for watching.

Cosmic Disclosure: Contact Is Made

Season 2, Episode 1

DW: All right, welcome to the show. I'm **David Wilcock**. And we are absolutely having fun here. This is all new information, even for people who think they know it all. I think we're just peeling away the layers of the onion here. And it gets more and more interesting as we go. I'm here with **Corey Goode**. And we are discussing insider information that he gained through his work in the Secret Space Program, or what's often abbreviated to SSP. **Corey**, this Secret Space Program, how does something like this get started? If our conventional technology seems to be so primitive as far space travel is concerned, did the space program actually have some help? Was there some outside assistance that allowed it to develop this far at such an early time in history?

CG: Actually, the reason there's such a wide range in technologies in the Secret Space Program and what we have down here is that this is a complete breakaway society.

DW: What does a breakaway society mean?

CG: It is a society that is so divergent from the one that it came from that it's a completely different society that runs on totally different technology, different social dynamics, different control systems, that are unrelated to the ones that it came from before. It broke away. And it's now existing separate from.

DW: What might be an example of a different social dynamic?

CG: Well it's definitely more of a controlled, totalitarian regime.

DW: Really?

CG: Yeah, yeah. The current era breakaway civilization really began in Germany, as far back as the '20s, but especially in the '30s. There were some of the German secret societies that were doing a lot of really interesting work. They were some of the first that didn't separate science and what our mainstream science considers esoteric spirituality kind of topics. They intertwined them. And they had some groups that were doing channeling, trying to contact groups from other worlds. And they were

also scouring the Earth for texts-- ancient texts from the East that had talked about ancient Vimana and other craft that they hoped that they could get information from to engineer craft from.

DW: One of the most contentious pieces of research that I came across dealing with German occult societies was apparently one of the top occultists in the time, who later advised Hitler, saw a talk by Gurdjieff. And Gurdjieff described this grand hypothesis of a symbol that was showing up, a sacred symbol, literally all over the world. All these different ancient cultures had this symbol that the Hindus called the "sah-wah-STEE-ka," or swastika. Do you think that the Germans in these occult societies, by seeing this almost worldwide prevalence of one symbol, were they reconstructing what they felt was the traces of a worldwide ancient advanced civilization of some kind?

CG: I don't know that for sure. But I know that as far back as the late '20s, and through the '30s, some of these secret societies were already well into expeditions all across the world, looking for ancient texts and relics that they could start to piece information together to create technology from, modern technology from.

DW: Also I did a ancient aliens episode not too long ago on something called the German Roswell. And I'm wondering if you'd ever heard of that.

CG: I believe it's 1936, a crash in the Black Forest.

DW: Right, on Eva Braun's family's land, apparently. And she later became Hitler's wife.

CG: I read that there was a crash and that there was technology recovered in the glass pad. But most of my knowledge goes to the contact that was made through the channeling, where they made contact with another civilization, and ended up arranging meetings with them and also, through their expeditions, ended up making contact in the Himalayas with the ancient breakaway civilization that a lot of people call the Nordics that they started to work with. They were working with these two different groups that helped them put this together.

DW: One of the most common things the critics keep saying is **Corey** has no proof. But when you're describing channeling, this is something that people can go and read for themselves. It wasn't all kept secret, right?

CG: No, a lot of this is out in mainstream. And people, I think, have written books and stuff about.

DW: So this is the Vril Society--

CG: The Vrill Society.

DW: --Maria Orčić.

CG: Right.

DW: Can you tell us what you know about the channeling, like did they form a contact with some sort of extraterrestrial group?

CG: Yes, they made contact with one of the Draco Alliance groups. And it was when they drew a picture of the face, a lot of people today say it looks like the Gray, or the Reptoids, which look very much like the Grays, except they're reptilian looking.

DW: Was that group here already before they made contact? Or did the contact draw them over to our solar system?

CG: The Draco, according to the glass pad-- smart glass pad-- had been here at least 375,000 years. And they considered Earth theirs.

DW: What do they look like? Where are they from? What's their story?

CG: Well the Draco are-- most people picture them as only these large reptilian group. But the Draco Alliance is made up of a lot of different beings. Most of them have some sort of reptilian blood in them, some sort of reptilian genetics. And I guess you could say they're very genetic purists. They like to have beings involved in their alliance that have some sort of reptilian genetics. But there have also been other insectoid-type beings that have been associated with the Draco Alliance.

DW: When you say reptilians, you're talking about a humanoid body?

CG: Right.

DW: But with a reptile-type appearance to it?

CG: Right. Reptilian skin, reptilian eyes, muscular build, reptilian disposition-- very aggressive-- and what a lot of people probably would picture as a demon. That's probably where a lot of the demon and devil ideas came from, the way they were depicted in medieval art.

DW: And you also said Reptoid as if it was something different from reptilian. So could you explain the difference?

CG: Yeah the Reptoids look-- they have a more narrow jaw, elongated head, and eyes that are larger. They look a lot like what people picture as the alien that you would see stamped on a sign at Roswell, the typical Gray.

DW: But there would be a difference between a Gray and a Reptoid?

CG: Definitely. And there are a whole lot of different beings that get thrown into the Gray category. There's a lot of confusion with Grays. There are quite a few different types of beings that get tossed into that category.

DW: So why is the term Draco being used for these people?

CG: I don't know the genesis of the name. I don't know if the name is something that came from them or comes from a more ancient derived manner. I don't know where the actual name comes from. I have heard all of the stuff that's on the internet about the Draco star cluster and that kind of stuff. But I don't know for certain.

DW: But the term Draco sounds a lot like dragon.

CG: It does.

DW: And Dracula, I guess, would be another similar thing.

CG: But I don't know which-- the chicken or the egg, I don't know which came first.

DW: This obviously starts to get immediately into the **David** Icke kind of stuff. To your personal knowledge, are there people on Earth that are reptilians that shape shift to look like human beings?

CG: The only type of shape shifting that we encountered when we interrogated intercepted beings was done through a technological means.

DW: OK. So this idea that the so-called Illuminati are in fact reptilians that are masquerading as human beings and they don't look like that at all is not anything you encountered in your line of work?

CG: It's not anything I encountered.

DW: So just briefly, if you have-- we've talked about avians that look human but they have birdlike features. Now we're talking about reptilians that look human but have birdlike features. Is the biome that we have on Earth-- meaning single-celled organisms, algae, vegetables, plants, mammals, fish, birds, reptiles-- is that type of thing a fairly common pattern for worlds that are Earth-like in our galaxy?

CG: Yes. And it seems to be some sort of-- there's some sort of humanoid template.

DW: Right, so different types of beings that we see on Earth could evolve into a human-like form, depending on the conditions of that planet.

CG: Right.

DW: And you're saying the Draco basically were like interstellar racists and found others who had evolved out of reptilian life or insectoid-type life. And that was their preferred group.

CG: Right. Or they genetically interfered, one or the other.

DW: What was their objective in coming here in the first place? What did they want from our solar system or from humans on Earth?

CG: Conquests, furthering their dynasty, their Draco alliance was-- they're all about spreading their empire.

DW: So the German occult societies-- were they contacted, or did they try to make contact with the Draco? How did that actually happen?

CG: They reached out and made contact, consciously, to this group.

DW: Through this Vrill Society?

CG: Right.

DW: And you also said that there was a Nordic-looking group?

CG: The German secret societies had been doing a whole bunch of expeditions. And as they were in the area of the Himalayans, they ran into a group of Nordic-looking beings that presented themselves as

alien, ETs. And they were actually an ancient human breakaway civilization that had existed under the Himalayas for tens of thousands of years.

DW: Under the Himalayas?

CG: Right, and further on in a network of cities connected underneath the ground.

DW: Had they reoccupied the stuff that was built by the so-called ancient builder race?

CG: Yes, but they had actually built out a very, very sophisticated, high-tech-- they were a very sophisticated, high-tech civilization on their own. And they built out their own high-tech infrastructure.

DW: But this was one of these underground areas, as you said before, that has the bioluminescent bacteria and has trees and running water and its own evolutionary path of animals and fish and birds and all that kind of stuff?

CG: But their's was closer to the surface, underneath mountains and networks that reached down to that area. And they called themselves the Agartha Network.

DW: Really?

CG: That was according to the documentation. And they had a space fleet, or a space program, that they called the Silver Fleet.

DW: This sounds a lot like people who have been contacted by what they think are extraterrestrials, the so-called Nordic ET is a pretty common thing to hear about.

CG: Yes, that happened a lot by this group that pretended to be ETs. And later on that also happened by this German group that created a breakaway civilization using technology they obtained from the Draco and this Agarthan group under the Himalayans.

DW: Do you think these Agarthans are the reason why the Germans became so obsessed with blonde hair and blue eyes and said it was a master race?

CG: Most likely.

DW: What did the Agarthans tell the Germans about themselves? Where did they say they were from?

CG: I believe they said they were from the Pleiades or something like that originally.

DW: So take us now through the origin of the space program based on these contacts. First of all, did the Draco and the Agarthans get along with each other? Did they know about each other? Did they have some kind of partnership?

CG: They had an understanding. They weren't allies. The Draco do not play well with others that don't bow before their feet. But they had an understanding to stay out of each other's hair and scales.

DW: So how does this turn into space travel? Who gave the Germans the space travel capability? How did that develop? Because obviously they're not going to build a space program without space travel.

CG: Right. Well the Germans, they were very intelligent. And they had already made some pretty excellent discoveries on their own from observing nature and the fact that, unlike in the West-- like I said before-- they didn't separate science from spirituality and some esoteric beliefs. They actually would use some esoteric beliefs, some of what we would call magic or black magic, at the same time they used science. They mixed it. And this actually gave them an edge.

DW: Did you ever run across the work of Viktor Schauberger in any of the documentation you saw?

CG: Yes. Yeah, he originally studied the fish, or the trout, travelling up the stream, up the waterfalls and stuff.

DW: It appears that Schauberger saw that there was some kind of antigravity effect with trout and salmon swimming up a 30 foot high waterfall and just gliding their way up.

CG: Yeah, OK.

DW: So did you encounter any information suggesting that Schauberger was on the right track, that he actually did invent something real?

CG: There were not only him. There were several German and Polish and I believe other scientists that were having some pretty good interesting breakthroughs that had that information confiscated and brought into these secret societies.

DW: Did these extraterrestrial groups, like the Draco and the Agarthans, give assistance to the Germans at some point so they could perfect or make a greater development of progress with what they were already working on?

CG: Yes. They had already started to build some pretty interesting devices based on some ancient texts and information they had found on the Vimana, creating mercury vortex electrogravitic devices that created a gravity-canceling technology.

DW: When you say mercury vortex, what are you referring to? What would this technology look like if we were going to see it?

CG: Basically in a glass cylinder with mercury in it, they would spin it at extremely high velocities and--

DW: Like a ring, a glass ring?

CG: In a glass cylinder.

DW: Oh, a vertical cylinder.

CG: Right.

DW: OK.

CG: Or sometimes in a--

DW: Sphere?

CG: Sphere. But usually it was in a cylinder. And then from the top and the bottom they would spin it at very high velocities and then apply very high voltage to it.

DW: And that causes the antigravity?

CG: Yes. And then they started doing counter rotating copper plates as well-- involved in it as well.

DW: So I know one of the books that I've seen that really talks about this Bell craft quite a bit is "The Hunt for Zero Point," by Nick Cook. He's done a lot of really original research on this subject. To your knowledge, when was the first Bell craft actually constructed and became operational, at least they got some kind of an effect out of it?

CG: Not quite sure. I can't really remember the exact dates and details from what I was reading. They were doing that stuff in the early '40s. I do remember some of the accounts I read about the Bell. I

remember they had several that they had tethered that had broken loose from the tethering and had pretty much just disappeared.

DW: Really?

CG: And then they had others. It was a process, a scientific process. And supposedly there were some scientists that died from getting too close. And they had some explosions. They had a lot of problems getting that started.

DW: Did they have little propellers that whirled the mercury around inside the cylinder? Or how did they make it move?

CG: From what I understood, there was an actual huge electrical cable that went to it and fed electricity to motors that spun very high RPMs and spun the mercury around. And interesting thing that happened, something that was dealt with later, is they discovered that heavy electricity-- I mean seriously heavy electricity-- applied to mercury causes the mercury to turn into gold.

DW: Really? Like alchemy.

CG: Like alchemy. And these cylinders, glass cylinders, kept the mercury-- kept turning to a coral-looking gold. And this was seen as a problem. Creating gold was seen as a problem.

DW: Why? Why would that matter? Wouldn't they want gold?

CG: No, they needed a golem metal, liquid metal, that would stay liquid at high temperatures, high RPMs, and that would conduct electricity for long periods of time without transmuting. And they eventually engineered a different liquid metal.

DW: But what would happen to the craft if it starts turning into gold?

CG: It becomes unstable and crashes.

DW: Really? Very interesting. Did the Draco or the Agarthans give them direct assistance to make this Bell craft work better, to solve the gold problem, as one example?

CG: Yes. It was after they got to a certain point of technological achievement and ongoing diplomatic relations with both these groups that they started getting scientific help in the form of liaisons coming in and helping them, almost like scientist exchanges. And once they developed a stable, working,

antigravitic craft, they then started to form more and more of breakaway society from the German dictatorship, or the German leadership, and started to keep more things secret and do things their own way.

DW: So you're saying this is not necessarily Nazi?

CG: No.

DW: It's more the German, occult secret societies?

CG: Right, those secret societies ended up creating Nazism.

DW: But Nazism broke away from them somehow and didn't adhere to what they wanted?

CG: I guess. That was more of a mainstream government, control the people kind of thing. They were more interested in starting their own breakaway civilization that had nothing to do with any groups, to have their own civilization, their own master race, their own space program. They had high ideas.

DW: In "The Hunt for Zero Point," Nick Cook, doing his research on this Bell craft, said that the Nazi code name for the project was Chronos, which means time. And he said, in the book, that-- and this was based on documents that he was able to find-- that apparently time started to get weird when they began playing around with this. Did you encounter any information of that sort?

CG: Yeah, when you're playing with electrogravitic technology, time and space, the veil between them thins. So you start to have anomalies.

DW: So what would be an example of an anomaly?

CG: Well an anomaly would be you would travel-- any time you're traveling at a certain speed, not only are you traveling a distance, you're traveling in time. And if they create a situation to where they jump from one place to another really quickly, they have not only jumped in space, but they have also time travelled.

DW: Wow.

CG: So it starts to blur, the time-space veil starts to blur.

DW: Well, we're out of time for this episode. But I think what we're going to have to do is continue this discussion. Because we haven't even really gotten into how these German occult societies then made their way into space. And I want to just stay right on this track. So next time coming up, we're going to take this very interesting discussion and really blow it out into the cosmos and get into information that until I met you I really had never heard before. This is some of the most heavily-guarded insider stuff. Even the insiders who know what they're talking about typically don't want to tell you this. But we're just going to release it all on the show. Because as you've said, the Alliance wants this stuff to come out now. And it's a great honor to have you here so we can start to bring out more and more of the suppressed history of our own 20th century. So **Corey**, again, thank you for being here. And I'm really glad that you've decided to do this with us.

CG: Thank you.

DW: All right.

Cosmic Disclosure: Agarthans: Advancing the Frontier

Season 2, Episode 2

DW: All right, welcome. I'm your host, **David Wilcock**. And it's very exciting to be bringing you this cosmic information, blowing the lid off of government cover-ups, conspiracies, and the lies that have been said for so long. I want the truth. I think you want the truth or else you wouldn't be here. And the truth can require a little flexibility in your belief system, because the more we get into this stuff, the more we find out that everything we think we know is nothing more than a fairytale, and the real world is far more interesting, far more complex, and far more wondrous than we could ever imagine.

And so, **Corey**, last time we were talking about the history of the space program. And in modern times, you said that starts with German occult groups.

CG: Correct.

DW: You said that there were two major intelligence civilizations that the Germans came into contact with that helped them perfect their bell craft that was an anti-gravity technology.

CG: Right. They were already well underway on their own. And these two other civilizations helped them develop it to a perfected point.

DW: And you said that one of these civilizations is called, or is called in the space program, the Draco.

CG: Yes.

DW: And the other ones are called the Agarthans. And they, you said, were underground in the Himalayas.

CG: Correct.

DW: When did these Agarthans live above ground?

CG: It's not fully known. It was tens and tens of thousands of years ago. They've been underground for many tens of thousands of years.

DW: Did something happen to the surface that they felt they had to flee, like a pole shift or something like that?

CG: Something-- it was a cataclysm that caused them to go underground. And cyclically in time, Earth has gone through several cataclysms, as modern archaeologists and geologists have shown.

DW: It starts to sound a lot like the Greek gods, where the Greek gods supposedly had blond hair or blue eyes and really didn't seem like very nice people. They were warring with each other. Zeus' thunderbolt, these depictions of weapons in "mythology," quote unquote, sound like a handheld technology of some kind. Do you think there might be a connection between the Greek gods and the Agarthans?

CG: Absolutely. They presented themselves to service to surface populations as though they were gods until we reached a certain sophistication level. And after that point, they started representing themselves as aliens or ETs. And I guess after we became sophisticated to a point to where we didn't believe that everything that happened was magical, we understood technology, they had to change their narrative from one of being gods to one of being extraterrestrials.

DW: You said that their underground civilization was a very advanced city.

CG: Well, a network.

DW: Oh, there's a network of cities.

CG: Right.

DW: Do they have their own transportation system between their cities?

CG: I haven't been there. I don't know. But they call it the Agarthan Network.

DW: What would these cities look like if we were to see one? Did you ever see any images of them or videos of them?

CG: I never saw images or any information other than that they were extremely advanced and self-reliant.

DW: Have they had craft the whole time they've been underground so they could fly around?

CG: Yes. And they have a fleet that they call "The Silver Fleet."

DW: Let's get a little more into the Draco for a minute. I can't help but think you're saying that the smart glass pads told you they got here 375,000 years ago.

CG: Approximately.

DW: Is there a connection between the Draco and what the Sumerians called the Annunaki?

CG: Some research shows that they were in contact and doing experiments on human beings a long, long time ago, going way back. This is separate from the human-type ETs that are in this super federation that have those 22 different programs. So this could be what Sitchin was talking about as the Annunaki. It was explained very much in detail to me that Annunaki was just a Sumerian term that to us today means ETs, those that from the heaven came, and that it referred to more than one group. But it seems pretty obvious that they're referring to some sort of Reptilian in those texts.

DW: Well, when you actually look at the Sumerian carvings, not only do you see these people who are at least twice as tall as the humans around them, you see Avians. There are Sumerian carvings of human-looking bodies with a bird head stuck on top, which is very interesting. So that would support what you're saying. Annunaki is more than one type of ET.

CG: Right.

DW: Are you aware of there being other Avians out there besides the Blue Avians?

CG: Yes, there's several different types. Some of them are quite unfriendly.

DW: Really?

CG: Quite unfriendly, yeah. But they are more of the 4D, four-density kind of technological level. They're technologically based. They're not higher density, what we would call etheric or spiritually based.

DW: When you see a creepy movie like "Eyes Wide Shut" or other depictions of cabal groups meeting where they wear these masks, it seems like a lot of the masks are Avian masks, meaning that the person is now a human but they have a bird-like head. Do you think those Avian masks might somehow be related to Avians having visited us in the past?

CG: Ancient Egyptians have depicted Avians like Thoth and Horus. And there's been talk of maybe, I think in the Law of One, that a six-density group came down and taught them certain information, and as soon as they left, the group distorted it and created a cult that became negative. And then they became associated with negativity.

DW: That's absolutely right. How right do you think Sitchin got? Do you think that the Draco spliced their genetics with our own to create the Adam or the primitive worker of the Adamu?

CG: I'm not certain if they were the group that did that. I know that there is-- and this is disturbing for a lot of people to think, but we have quite a few different races, genetics spliced in with ours. And there is a small amount of Reptilian DNA that's spliced into human DNA.

DW: The Draco, to your understanding though, have been here the whole time? They didn't go anywhere?

CG: There have been battles on Earth over Earth over some time. There have been times to where the Draco have been driven back and had remnants here. There's been times where the Draco came back and drove other people, other ETs, groups away. There's been a pretty wild history over hundreds of thousands of years on this planet.

DW: Yeah, you see in the Sumerian records the Lamia, which are the serpent people, you have the Hindu Nagas. There's a serpent temple where it's to the serpent gods. Then you have the step pyramids

in Mesoamerica where you have these Draco heads on the bottom of the pyramid. Everybody thinks that's just a snake head. You think that these are examples of where Draco had gotten a foothold in Earth?

CG: It could be. There are other beings. There are a raptor kind of being that some people confuse with the Reptilians that are more bird-like in the way they move. And a lot of them have plumes of feathers down the back. They're kind of a mix between Reptilian and Avian bird.

DW: Do you think that pretty much almost anything we could imagine in terms of a humanoid-looking being is out there somewhere?

CG: Pretty much.

DW: So now let's bring this back. And you're opening up other subjects. And I'm not going to abandon those, but I want to stay on topic. Because there's so many ways we can go when we start talking about all this. The Draco may have this connection to the Annunaki, the Sumerian connection. You said they'd been driven away. They came back. These are nasty folks, right?

CG: Yeah, very much.

DW: The legends of like when people are supposedly being sacrificed at these step pyramids-- did they want that kind of tribute paid to them, like human sacrifice? Is that one of their things?

CG: Yes.

DW: So these are nasty guys. Why would anybody want to work with them?

CG: Well, they're pretty nasty themselves.

DW: The German occult societies.

CG: And later on, other Western occult societies.

DW: OK, so why would anybody in Germany, or anywhere for that matter, want to work with a group that seems to be negative that is clearly more powerful than they are? What could they possibly gain out of something seemingly so stupid?

CG: Well, technology and also an alliance with the group that once they started going out into outer space, they started running into other groups. And there are other groups that are not so friendly. So they decided to ally themselves with, I guess, the tough kid on the playground.

DW: What was the role of the Agarthans in the early development of how this transitions from them just having bell craft to actually starting to build a breakaway civilization?

CG: The Germans really took more to the Agarthans.

DW: They did?

CG: Yes.

DW: OK.

CG: They looked more alike, the blond hair, the blue eyes. It kind of went along with the master race.

DW: Are the Agarthans about the same height as us?

CG: Yes, maybe a little taller but pretty much within the same height range.

DW: And what would they be seen as wearing?

CG: They would wear unitards. The Germans later on would wear the same uniforms and fly around and pretend to be ETs as well.

DW: Really?

CG: Yeah and make contact with people in the '50s and say that we're ETs. We're here for the benefit of the planet Earth and make contact.

DW: Do you know whether the Germans made contact with the Agarthans first or the Draco first? Or was it both kind of in the same window of time?

CG: I believe it was with the Draco first. But they could have started as a slow connection with the Agarthans when they were doing a lot of their excavations in the East looking for ancient writings that had information that talked about Vimana and that kind of stuff.

DW: Did the Agarthans welcome the Germans down into their societies and give them the dog-and-pony show underground and show them all this sizzling, amazing stuff?

CG: It was more towards the end of the war that the Agarthans invited some of the Germans to come to the Agarthan network. They showed them the ancient ruins underneath the ice of Antarctica.

DW: What ancient ruins?

CG: There were some ancient ruins underneath the ice of Antarctica.

DW: For those who are not familiar with this, most people would think that Antarctica has just always been a glacier. So how could you build under a glacier?

CG: No, there are a lot of ancient ruins that are completely crushed by glaciers. There's a lot of underground cities and networks underneath. And there's also a lot that's preserved by-- there's a lot of thermal activity that people don't realize, like volcanism. It's in ice, but it looks almost like lava tubes, huge areas of domed ice. And underneath, there are cities.

DW: And the temperature from the volcanic activity keeps it warm enough that you can live their comfortably?

CG: Right.

DW: Well, that's sort of like the Eskimos building an igloo, right? It's really cold outside. I did that in Boy Scouts. You build a snow fort. It's called a lean-to. You dig into a snow bank on the side of a tree, your breath immediately starts to melt the snow. It turns into ice, and even though you're surrounded by ice, you're like very warm and comfortable in there.

CG: Yeah, the stored-up thermal energy in the ground comes up.

DW: So just to clarify, though, are you saying that some kind of Earth crustal displacement or actual physical movement of the Earth's rotational axis took place so that what we now think of as Antarctica at one time was a habitable land?

CG: It was more like Australia more than likely.

DW: Really? And you're saying that there was some settlement on that land before whatever this event was that took place?

CG: Right, there was an ancient civilization there.

DW: Is this the Atlantean flood, the 13,000-years-old catastrophe, as far as you know?

CG: This is much older.

DW: It's much older than that.

CG: Right.

DW: Really? Do you know what the time frame was?

CG: No. I know that people at first thought that this was the Agarthans' original home. But the information that I read was that it was much too old to have been their home.

DW: Wow.

CG: So I don't know. It's been a long time since I read it. So I don't know the age differences that made it impossible for it to have been their original home. But they were obviously aware of its existence.

DW: Well, I'm hearing the bleeding of some sacred cows being slaughtered here.

CG: Yes.

DW: Is this ancient builder race? Is it that kind of old, like millions of years old?

CG: No.

DW: Oh, so something in between.

CG: Right.

DW: What did the Germans see? First of all, had anybody been to Antarctica before this? Was this like the first time in modern times with modern humans? I guess there have been a few-- there was Cook, right, who went there or something?

CG: Yeah, I think there have been a few expeditions there. But this main city, there were three occupied cities under the ice. Two were--

DW: Occupied?

CG: Right.

DW: In Antarctica.

CG: In Antarctica.

DW: When the Germans got there, they were already occupied?

CG: Well, one was somewhat in disarray. But it was perfect for their U-boats to come up under the ice and come up in a cavern area.

DW: The U-boat is a submarine?

CG: Submarine. And it was perfect for them to build out from there. But there were two other cities further inland that were already occupied by other groups. I don't know who these other groups were. But they ended up being allied with these Germans.

DW: Really? So did the Agarthans tell them where to sail? The Agarthans already had identified this?

CG: Right.

DW: Why would the Agarthans need the Germans to develop something when they have this vast Agarthan network of all these underground cities already?

CG: Well, they invited some of the Germans to come into their Agarthan network. But they assisted with the treaty they had. They assisted the Germans in locating areas in Antarctica and in the east part of South America to create underground bases and also above-ground cities that were almost entirely German.

DW: So would this sort of be like a signing bonus that the Germans get, like some of the things that the Agarthans knew about but they didn't like that much, maybe their less hospitable areas, and the Agarthans just sort of gave it to them as a carrot?

CG: I think it was just a part of their treaty.

DW: Right. The Agarthans hadn't developed out these places before? They were largely abandoned, like the one place in Antarctica you're talking about?

CG: Yeah, the Germans developed them out.

DW: And you said that when the Germans got there, it was in disarray. So just talk us through. The U-boat goes under the ice. It pops up. You say it's warm in there because of volcanism. It's like a dome.

What do they see when it pops up? Is there grass? Do you actually have a biome? Do you have some life forms? Or is it all just really icy and cold?

CG: I'm not exactly sure about all the fine details, but I know there were a lot of structures that were abandoned. Some were damaged. And it was just in disarray. And there was already an underground complex that they could reoccupy and refurbish and set up.

DW: Structures could be just about anything. Are we dealing with like ancient builder race type stuff, like pyramids?

CG: Not that old, no.

DW: What would these structures look like if we were going to see them now?

CG: I don't know. I have not seen images of them. I just saw text.

DW: How advanced was this technology? Are we dealing with like pueblos?

CG: It was advanced building structure. But there was not advanced technology there. It apparently had been picked over.

DW: When you say advanced building structure, you mean superior to what we have now with like Manhattan skyline and skyscrapers?

CG: Well, superior to what they had then, at least, in the reports that were written up during that time period.

DW: How much of a detachment of personnel did the Germans get down there to explore this? First of all, I guess do you know how big it was, how many square miles?

CG: No. They had a fairly large detachment-- I don't know how large-- of people in Antarctica and in Argentina, Brazil, all spread out in South America, that would resupply the Antarctic base. They had infrastructure and a network that they set up down there that they put quite a bit of effort into setting up.

DW: Did they largely use submarines to get to this Antarctic base so they could avoid detection from the air?

CG: Well, it had to be reached from submarine or from their highly advanced aircraft.

DW: OK. The Agarthans, you said, also directed them toward South America. Is this ancient builder race type stuff? Or were they just settling in the jungle and building up their own little place in the jungle?

CG: In the jungle and in caverns.

DW: Caverns from the ancient builder race?

CG: Not ancient builder race, just caverns that they built up themselves with their own infrastructure.

DW: So nothing ancient or interesting about it.

CG: Right. That was completely building up with their own resources.

DW: OK, so did the Antarctica come before they ever left the planet to go anywhere else to start building anywhere else?

CG: Well, they were already starting to leave the planet. But that came as it was becoming obvious that the Axis powers were going to lose the war.

DW: The Antarctica came?

CG: Right.

DW: So they needed like a place to hide, and that was their best bet?

CG: Right. So they started building that out years in advance. They knew that the war was going to go badly years in advance.

DW: So with a combination of technological endowments from the Draco and the Agartha, the Germans perfected their bell craft. Because you said they're not really Nazis, right? It was the German occult societies.

CG: And the bell was not a craft. It was more of just like an engine.

DW: Oh. That's the shape of the engine is the bell.

CG: Right. People couldn't get inside the bell. Yeah, but sorry, go ahead.

DW: Where did they go first? And what did they find that was interesting?

CG: First, they went to the moon. And they had a couple failed attempts at building a base. Finally they found--

DW: Wait a minute. How much of a fleet of these bell craft did they have?

CG: Quite a few.

DW: Thousands?

CG: No, no, probably less than 100 in the beginning.

DW: Were any of them large enough to carry a decent amount of cargo with them?

CG: Yeah, they had several different sizes. I think there were three different sizes.

DW: What would the largest size be?

CG: I think 90 feet across, I think.

DW: So you could hold a pretty good amount of stuff in there.

CG: Not a whole lot with the amount of room that they had in the area. But in the 90-foot ones, it was a lot more than you could include in the ones that were like 24 feet or something. I can't remember the exact dimensions.

DW: Now you said before that the Super Federation folks who have been running 22 programs to tweak our DNA and mix their genetics with our own, that there's a huge settlement on the dark side of the moon where everybody has their own diplomatic region and boundaries and all this.

CG: Yeah, multiple settlements.

DW: So why wouldn't those folks just want to blow up the Germans if they're showing up and trying to find territory on the moon themselves?

CG: Because the Germans built in a diplomatic area of some allies they've made.

DW: Really? Would that be the Draco?

CG: I believe it was most likely the Draco.

DW: So it was because of some sort of complex treaty that the Germans were able to do anything at all?

CG: Right.

DW: You mentioned these Agarthans working with the German occult societies I guess in the 1930s and on into the 1940s. Are these Agarthans still here today?

CG: Yes, very much so. They presented themselves as ETs to the secret space program, and the secret space program figured out that they were not what they claimed round the late '70s, '80s time period. I think it was maybe in the '70s. And they pretty much stopped pretending they were ETs to the space program, because the jig was up. But they're still presenting themselves as ETs to a lot of people on the surface of the planet.

DW: Do they have a seat in this Super Federation Council? Are they one of those--

CG: No.

DW: Oh, they're totally different?

CG: Right, there's a different group that is very similar to the way this group looks. But they are indeed very much taller. They don't look like our average size. But they have a little bit larger foreheads but do look very much like the Nordic kind of look.

DW: What's their height?

CG: Around the 10-foot, 9-foot range.

DW: Wow.

CG: So there's a difference.

DW: Do the Agarthans meet with other intelligent civilizations? Or do they pretty much keep to themselves? What's their role in today's extraterrestrial geopolitics?

CG: They have alliances with other ancient breakaway civilizations. We're not the only one. And they have alliances with ET groups.

DW: Well, we're just getting the surface scratched here. Obviously this question of the development of the space program is going to take more than two episodes to complete. But as long as it's interesting, which it certainly is, I'm happy to keep this thread going. So we've talked about a lot of fearful stuff. And could you just again help reassure people who might not have seen other episodes? Do we need to worry about these Germans or these Agarthans or these Draco? Are we just like filet mignon waiting for them to come pick us up?

CG: No, the damage is already done that they were going to do. There has been a new group that's moved into the solar system, and they are pretty much neutralizing any of their attempts to start any large-scale problems. And any type of fearful stuff you see on the news, I would disregard. There's more of a positive future ahead of us if the secret space program alliance and the sphere alliance has their way.

DW: We don't want fear, right? This is what these negative groups have been trying to do is generate fear.

CG: Right.

DW: And it turns out that there's now very effective countermeasures to stop them from being able to achieve their goals.

CG: That's right.

DW: Excellent. Well, **Corey**, I want to thank you for being here. As always, I want to thank you for watching. I'm just trying to get my head screwed back on. This is really wild stuff. And we'll be back next time with more of the history of the secret space program, more about the development of colonies on the moon, colonies on Mars. So stay tuned.

Cosmic Disclosure: The Gonzales Enigma

Season 2, Episode 3

DW: Welcome to the world of the shocking, the bizarre, and the seemingly unbelievable [Cosmic Disclosure](#). I'm your host, **David Wilcock**. We're interviewing **Corey Goode**, the insider's insider, a man who has as much knowledge crammed into his brain as all the other insiders I've met put together. Truly a fascinating conversation that we're having. **Corey**, welcome to the show.

CG: Thank you.

DW: We were talking about Lieutenant Colonel Gonzales, who is a mysterious figure that has aroused a great deal of curiosity on the internet. Some people are saying that he's about to come forward. Is that true?

CG: No, there's no plan for him to be coming forward any time.

DW: OK. People on the internet are thinking, well, we just want to see another guy who knows what **Corey** knows. Why is it a bad idea for Gonzales to come forward?

CG: He is-- he has a cover life here on Earth. He isn't down here very often. If he was to expose himself at this point, it would be very dangerous for him and the operation. He doesn't have any children or family, and some would think that it would be, I guess, safer for him to come forward than me with having a family and children. And I agree to a certain point.

DW: So the Blue Avians obviously have been assisting Solar Warden trying to break out [cosmic disclosure](#) for humanity. What's the history of that? What's the history of them contacting you? Because I certainly remember that very amazing day, February 27, 2015, when you told me in a Skype text that the Blue Avians had asked for you by name from the space program alliance. So what's the history here?

CG: As you remember, I was telling you that I was in contact with a being that I wouldn't go into details about, I wouldn't even describe to you.

DW: And I respected you for that, but it was also something that made me extremely curious, that with all of the really outrageous stuff you were telling me, why is he holding back on this? About all I knew was that they were blue, and that was it. I think that's about the only thing you ever said, and that it had something to do with your family and your kids.

CG: Right. And that much I still can't talk about.

DW: Right.

CG: But this--

DW: When did this contact happen with you?

CG: It goes back four years.

DW: OK. So four years before 2015 would be 2011, thereabouts. OK.

CG: And it turns out that Lieutenant Colonel Gonzales has been in contact with them for about the exact same timeframe.

DW: So around 2011 as well?

CG: Mm-hmm. And he had been in a liaison role between the Blue Avians and the Solar Warden-- well, the SSP breakaway faction that included Solar Warden. It's not just Solar Warden.

DW: It's not just Solar Warden.

CG: Right. A lot of people have been putting out that it was just Solar Warden. It's kind of a conglomerate of defectors from the different space programs.

DW: Right.

CG: And he had been presenting information from the Blue Avians for some time, and then all of a sudden out of the blue, they give him my name and information, and he comes to the SSP council, alliance council, and says, the Blue Avians have chosen this guy to be their delegate. And they were not happy at all about it. They wanted Gonzales to be the delegate.

DW: Without getting into any incriminating detail, what would this cover life be like? Does he have a house? Does he have a car?

CG: Yes. Lives in a house in a rural area.

DW: So people he would tell if he meets somebody that he has a particular job, and there's a whole cover story worked out where that job does exist and he could go there?

CG: Yes.

DW: Right.

CG: I'm very reticent to say anything more.

DW: Oh, no. Absolutely. There's just been this current on the internet of people thinking he's about to join us on a radio show or something, and we needed to specify that that's not about to happen. So you're saying the Avians contacted you and him in 2011. Was this before the new influx of 100 or so visible spheres of the size of the moon Neptune and Jupiter? Was it around the same time? Was it a little bit before?

CG: This was-- it was occurring before, and it was during the influx.

DW: OK. So it kind of seems as if there's a major push being made and that one of the initiatives was to move the spheres in, and another initiative was to grab these delegates starting with Gonzales, and then once you were apparently ready for this job, that then you were also invited in.

CG: Right. I was being prepared, but I had no idea I was being prepared or what I was being prepared for. I was still coming to terms with a lot of my past of what I had been involved in, and when I had gotten to the point where I had come to terms with it, I was dealing with the Blue Avians with some of that information.

DW: So when this contact first happened in your case in 2011, did you actually see them like the Android Jones illustration that we have? Were you seeing these beings, or was it like a blue sphere? What were you actually experiencing?

CG: They first introduced themselves to people in dreams, in a very lucid dream. And then they appear to you physically after they have prepared you through dreams.

DW: Which is exactly what they say in "Law of One" is the same contact protocol.

CG: Oh.

DW: Yeah. Now they say in "The Law of One" that they discontinued most physical contacts because the people that were getting them would get a big ego and would be worshiped by others as some sort of messianic figure. And one of the things about your story that has really fascinated me is that that prime directive sort of free will clamp-down on in-person contacts seems to have been lifted because of the need of the moment, because we need to get jump started into this golden age, and we need some help getting there.

CG: And after every meeting, I'm heavily warned about ego-- my own ego and this information becoming cultish or religion which it's not supposed to be by any means.

DW: Let's go back to that moment again, and tell us, what did it start with? You said it started with dreams. At what point were you aware that you were in contact with what you're now calling Blue Avians?

CG: I was very aware in the dreams, but it wasn't--

DW: Did they look the same as the illustration in these dreams?

CG: Pretty much. The illustration that is out is not perfect yet, but yes. That's the way they appeared in the dreams--

DW: In the dreams.

CG: --and in person when they finally did appear.

DW: Dreams, a lot of times, will have very odd metaphorical symbolic impossible things going on. You'll look over here, and then you look away, and then it's changing. So did these dreams seem to have that type of symbolic nature, or was it more like a lucid contact?

CG: It was very lucid, very real, very tangible. It was different than any type of dream that I had had before.

DW: So we're getting lots and lots of people on the internet who are trying to say that they've jumped right into this story line with you, that they're having the same contact that you're having, and they're trying to portray themselves as authority figures and act as if their information should be considered equally. What is the way in which most people are being contacted? Because it seems like a lot of these

are fraudulent. They don't really line up with what you're hearing. What is the way that most people are being contacted? What is a type of experience that might occur?

CG: Most people are being contacted having experiences with the blue orbs, which is-- the blue orbs are actually the highest density of the sphere being alliance. So I mean, they're higher density than the Blue Avians, but everyone seems to have locked on to-- I guess the Blue Avian, there's something romantic about it. People have locked onto it. But most people are having experiences with the blue spheres.

DW: What would that involve? What's actually happening?

CG: Usually a blue sphere or spheres appear to people and zip around or stop in front of them and pulse, and people receive either a message they remember consciously, or they just think they just saw a very cool thing and don't understand that they received a message subconsciously, or their higher self received a message. And they're receiving a message from these higher density beings for future reasons.

DW: Well, this is really mind-blowing, and we've talked about this privately, but I want to get this on camera. It is going to involve a little bit of self-disclosure and a little monologue from me, but it's very important. I had read "The Law of One" and the "Seth" books. Both Carla Rueckert and Jane Roberts, the channels of two of the best channels in modern times in my opinion-- both had these blue orb visitations very clearly delineated in the books. I was so aware of it that I was frustrated and said, why haven't they done that with me? Because one thing it says in "The Law of One" is that they will try to get to you telepathically. They don't want to have to do an in-person contact if they can avoid it. If they can get you involved like they did with me telepathically, that's better. So one day I'm in North Carolina visiting a friend. I'm meditating in a field. I see a UFO-- first time I'd ever seen one. It goes behind a cloud. The cloud goes away. It's gone. But because I'm meditating, I'm just like, OK. Well, now I've seen a UFO. Big deal. The only other thing I want-- and I said this is like a prayer-- the only other thing that I wish would happen that hasn't happened is I want an orb of light to appear in my room and give me an intelligent message just like what happened to Carla and what happened to Jane Roberts. Then I called my father a couple days later, and it turns out that my brother was on the other line at the same time. And he patches us both in together. I said, Dad, you realize this is synchronicity, right? He's like, oh, oh. Then my brother says, after I talk about my UFO sighting, said, well, that's funny. Something weird happened to me too. I said, what's that? He said, this orb of light appeared in my room and gave

me an intelligent message. And in his case, he was meditating, and his head actually dropped back, and then he saw this orb appear near the ceiling, and it spread out to about four or five feet wide, and it was like a vortex tunnel. It was an actual stargate in his ceiling pulsing, and we have a whole article on my website from 2001 called "**David's** Brother Receives In-Person ET Contact." And it gave him a message, and it said, the ascension that your brother is writing about will not happen all at once. It will be a series of increasingly uplifting inspirational experiences. You have had the first of these experiences, which was mind-blowing. So how do you think-- how did that strike you when I told you that my brother had this experience back in 2001 that was already in print on my website?

CG: I had no idea, but there are many, many tens and now hundreds of thousands of people that are having these experiences right now.

DW: Has Gonzales had this type of thing too? Is that part of how it worked for him?

CG: Yes.

DW: OK. What is Gonzales's role at this point? What's the difference between how he got contacted and how you got contacted? He was in the space program when this happened.

CG: The contacts happened exactly the same way, and he has been named a secret space program delegate. He's a delegate between the secret space program and the Blue Avians. I have been named a delegate between the Blue Avians and the secret space program alliance and a whole of the other groups they want to meet with but will not meet with one-on-one. And I have been put in the situation to meet in all these different federation council meetings, and he has accompanied me to several of these.

DW: Have there been trips that you've taken up into space since this all started that did not involve Gonzales, where you never saw him?

CG: Yes, but most recently, he's been very much a part of them. And when I was out here doing the last shoot at Gaiam, there were two extremely important meetings that were time-sensitive that he had to stand in, and one was with the Draco Federation Alliance, and that was a very traumatic meeting for him. But the second meeting was much more awe-inspiring and pleasant for him. And this was with the super federation of 40 main groups of ETs that were involved in these 22 different genetic and other experiments going on with humanity. And there were 20 other, making 60 groups, that are overall involved in this grand experiment.

DW: And this is some of your earliest experiences in space, right, was being a part of this? So just to briefly recap, what did you originally do when you went to these super federation conferences? How old were you, and what was your job?

CG: I was very young. I was barely in my teenage, pre-teen age years, and I was in an intuitive empath role, which now each of us, when we arrive, we have three intuitive empaths with us that intuitive empaths are there to detect deception or danger. And that's what I did, but now when Gonzales or I go to these meetings, we have that type of support for us.

DW: Were the beings in the super federation aware that you were there to detect deception?

CG: Yes. They all have this type of role.

DW: OK.

CG: I've described the large shuttle vessel that is modular. It can be changed for any type of mission. It's about 50, 60 feet long, and this vessel took him and his support team out to an area that's around the gas giants, usually in between-- around Jupiter and Saturn. And this is an area that you would not be able to see with a telescope it's inside a temporal distortion bubble, and you enter in this distortion, and you exit in the exact same place you entered from.

DW: Just like the fairy ring.

CG: Right.

DW: Yeah.

CG: And when you enter in, it is completely black. You don't see any stars. You don't see the sun. You don't see any planets. Completely black.

DW: Does the sun-- nothing is visible at all.

CG: Nothing. All you see is the station that the council meetings take place at.

DW: And what about other people's ships?

CG: You'll see other ships going to the dual docking arms, so his vessel docks. Him and his crew get off, and this is the first time that he had been actually acknowledged because he had been there

basically in a support role before with me, and they had only acknowledged me because I was there as the delegate.

DW: Can you just help us out here-- the visual like this is a movie now? What are we seeing? Is it like a whole city? Is it a structure that's just big enough to hold the council, or could there be a lot of other stuff going on in it?

CG: Yeah, it's an extremely advanced space station. And as he exited the ship and started walking down the passageways towards the main hall, the main federation council hall, he was walking, and people were acknowledging him for the first time, and there's a main foyer area to where people meet and greet before they walk into the main hall. And when you walk into the main hall, everyone sits in kind of like a horseshoe shape, and there's a main chair that's elevated, and then three chairs are lowered, and there's a rail that goes around.

DW: So there's one horseshoe for each of these 40 groups?

CG: For each delegation. And then the delegate sits in the chair, and then they have one advisor that usually stands to the back left. In this case, the room was extremely crowded. They knew that there was a big announcement going to be made, so it was like standing room only. They had extra delegation chairs for the full 60 group was there. And then they had seating and standing room area for a whole bunch of others.

He said that he was very excited to sit in his chair, because before when he had arrived, when I sat in the chair, it had operated like a universal translator to this universal strange ET language that was very monotone, and no one else heard or understood. And so he sat in a chair, expected some sort of weird sensation, but nothing. But he sat in the chair, and a being came up and made the announcements.

There was one of the beings that we're very familiar with that-- pumpkin-colored skin, large blue eyes, has a ridge that goes from ear to ear, very tall that wears kind of like a monk's type of robe-- and introduced him, announced for him to come to the front. And he went to the front and made an announcement that many were hoping to hear, that the inner barrier around the Earth was going to be relaxed so that many of the ETs that were trapped on Earth that were benevolent, that were here studying our oceans, studying our jungles could care less about humanity, that were just here to study our ecosystem, that were having a lot of problems being stuck here for so long, being stuck on earth.

DW: They were running out of supplies or--

CG: They were having all sorts of problems. They could then rejoin their support teams that were waiting for them outside the Earth's orbit far away. And the IEs all said when this announcement was made, there was a huge relief felt in the room. So he made the announcement that they were going to go back to the old style of grid patrols and kind of like an air traffic control of allowing people to come and go.

And then he went back and sat in his chair, and then the typical thing that happened when I was at the meetings. Each of the 40 groups just went to the front and did like a real short two-minute synopsis of how they have contributed to humanity and the grand experiment and why they are so great, why they've done what wonderful things they've done, and then they went back and sat in their chair one after another.

And then afterwards, they returned to their shuttle and returned back to debrief.

DW: What is it that these beings think they've done that's so valuable to us?

CG: They think that this grand experiment has been a great contribution to the entire galaxy.

DW: To the galaxy?

CG: Yeah, and beyond. They think it-- the Blue Avians have stated that even though some of these beings are very benevolent in our eyes, that they are still agenda-oriented and, therefore, a certain percentage service themselves.

DW: Are they seeing us as like a master race, like they're trying to mix up the ultimate human?

CG: There's like 22 agendas, and some of them are competing. And then also, we have the Draco agenda and all that, so it's very complicated.

DW: How could we benefit the galaxy though? I'm not sure I'm getting this.

CG: When you say "we," you're talking about this flesh and blood.

DW: OK.

CG: This is also a spiritual and a much larger experiment than most people realize. Some of these beings are incarnating as us.

DW: That's one of the programs, you're saying.

CG: Part of one of the programs. So some of these people that are starseeds or wanderers, and there are some of these groups here.

DW: Well, "Are You a Wanderer?" That title is our most popular "Wisdom Teachings" episode, and we have a questionnaire on there that you can watch that has details on if you have these characteristics, if you can answer these questions, then you're most likely an ET soul.

CG: And most of the people that are being contacted by these blue orbs are starseeds, are wanderers, and these cabal groups, I guess for lack of a better word, are very, very interested in starseeds and co-opting them and using them for, I guess, the dark side.

DW: So what is the cabal doing to try to find these wanderers and starseeds? What is their modus operandi?

CG: Well, they have many different ways, but with me, it was using standardized testing in schools. They constantly have people out there that are on the lookout for people with certain signs that show certain abilities, and then they find ways to further test them and see if they meet criteria.

DW: These people don't consciously remember in their physical incarnation that their past life was extraterrestrial.

CG: Right.

DW: They are bound by rules, where they have to play human and seem like they're just another ordinary person.

CG: Right. And the blue spheres visiting these people-- this is a part of an awakening experience. These people are going through an awakening right now as to what their role is, what their mission is in this lifetime, why they're here.

DW: Is this super federation aware of the energetic change that's going on with the sun, these tsunamis of energy you're talking about?

CG: Very much so.

DW: What's their involvement with that? How do they see that?

CG: Many of them had planned on being out of here when this happened for whatever reason, and that was the purpose of the outer barrier was to keep everyone that has had anything to do with the tinkering of our biosphere and humanity here, not to let them escape.

DW: Well, there is a line in "The Law of One" where it says that when this quantum leap takes place, if you're not ready to go to fourth density that your third density electromagnetic body will fail due to incompatibility. So that line would suggest that if these people are too heavily third density, and they're not pure enough to be able to go through this transformation that it would actually be like a death sentence for them-- crispy critters.

CG: Right. And a lot of what these ETs and the Blue Avians-- a lot of what they believe and work off of is what I hear in natural law and "The Law of One."

DW: What is natural law exactly?

CG: I'm learning a lot of these things. In the beginning, when I first started contacting you, and you were telling me-- I had heard, read a little bit about "Law of One." I still-- I need to learn more about "The Law of One." I need to learn--

DW: The Blue Avians told you to buy the book, and I saw it in your room.

CG: Yeah, and my wife has been reading it.

DW: And it hasn't even been cracked?

CG: No, my wife is almost through reading it.

DW: OK. She's a very clean reader then, because it looks brand new.

CG: Yeah. I haven't even read it. So I'm not doing exactly as well as I should be doing and learning some of these things.

DW: Wow, but you've done an amazing job risking your life coming forward. We're going to have a lot more to talk about. I'm your host, [David Wilcock](#), and I thank you for watching because you need to know the truth.

Cosmic Disclosure: Breakaway Begins

Season 2, Episode 4

DW: I'm jazzed up for this episode. Welcome back. I'm your host, **David Wilcock**. And we are delving deep into the world of cosmic information, the most highly classified stuff you could possibly get your hands on. It's been jealously guarded behind so many compartmented layers of secrecy that it was just never available before now. If you've been following our narrative arc and you've been watching through previous episodes, we've already covered some really incredible stuff. We discussed how the German secret societies as early as the 1920s and on into the 1930s formed diplomatic and political relationships with two different intelligent civilizations, one known as the Draco, which appear to be a various confederacy of reptilian-looking humanoids, and the other being the Agarthans, which are Nordic-looking people-- in other words, blue eyes, blonde hair, humans about our height, maybe a little bit taller, who presented themselves as being not from this world but as he revealed are, in fact, people who were originating here on Earth and due to catastrophic events, had to go underground. So now what we've been discussing is how this alliance formed and how Agarthans and the Draco allowed the Germans to be able to have the little extra help that they needed to make their way up into space. We were just starting to get to some really good stuff last time, and now we're back to continue the story forward. So **Corey**, welcome back to the show.

CG: Thank you.

DW: I'm just trying to keep my brain in my head here because the stuff that you're telling me-- what is it like to get brought into this world and to learn all these things? If you are walking around in society and you know all this stuff, what's it like to see people who think that we're alone in the universe and to think that this is all there is and there's no life after death, all this kind of stuff? What's it like to live in this world?

CG: You get used to it. You see people looking up at the moon, and I look up at the moon, and I look at it totally different than other people. You grow accustomed to it.

DW: So we were talking about the history of how our space program got developed, and this subject of the Agarthans is really fascinating. It seems to connect so many dots. When Graham Hancock wrote

"Fingerprints of the Gods," his hypothesis was that you have these blonde-haired, blue-eyed, Aryan-looking people who show up in boats to all these various indigenous cultures all over the world, present themselves as gods, and teach them things like how to create a water wheel, and then use the water wheel to start grinding grain, and how to do metallurgy, mathematics, astronomy. Do you think the Agarthans had a lot to do with rebuilding our societies in the aftermath of some sort of catastrophe?

CG: Yes. Yeah, that ancient breakaway civilization did, and there were others that did the same thing.

DW: So these Agarthans, you said, were a lot more favorable to the Germans because they looked more like us. And this is where they got this master race concept from, you believe?

CG: Either that or they were favorable to them because of their proclivity to a master race. I don't know which came first.

DW: So did the Agarthans fly with the Germans in their bell craft?

CG: Well, the bell was actually the engine component, or the component that caused the electrogravitic field. The craft were actually larger saucer-shaped in the beginning.

DW: What were the craft called in the documentation that you saw?

CG: When the Americans actually got their hands on them, they termed them ARVs, Alien Reproduction Vehicles.

DW: Well, just to loop back to my question because some people are going to be left hanging if you don't answer this, did the Agarthans ride with the Germans in these craft?

CG: Yes.

DW: Really?

CG: Yeah.

DW: Was this a frequent thing? Were they usually supervised and didn't just go by themselves?

CG: In the beginning.

DW: What was the size, you would estimate, of the Agarthan population? Are we talking maybe 10,000 people, 100,000 people? How big is it?

CG: I don't know. I know it was very large because it was a network.

DW: Really?

CG: This was a network of underground cities. In the Himalayas, that was the closest-to-the-surface city, and that seemed to be where they came and went from the most from the surface.

DW: Wow. So the Agarthans introduced the Germans to this ruined area that was under the ice in Antarctica. And you said that there was some underground development as well as on the surface.

CG: Right.

DW: Are we talking like basement cellars? Or how much underground infrastructure did they have down there?

CG: It was basically the same kind of underground caverns that had been built out by another civilization in ancient times.

DW: So it's pretty extensive?

CG: Yes.

DW: We're talking multiple levels down?

CG: Right, just like the description I gave to you one other time about the further you go down, you have kind of a honeycomb structure of caverns deeper under the Earth.

DW: Let's just jump to that for one second because I think a lot of people are going to have some trouble with that in the idea that, at least in conventional science terms, there's an understanding that the farther down you go into the Earth that the temperature is going to steadily increase. So wouldn't these people just be burned alive in some kind of super oven?

CG: That is the case for certain areas and depths. And then after those certain areas and depths, it begins to reverse.

DW: You actually get a cooling effect.

CG: Right. It gets exponentially less pressure and less heat, just as it exponentially gets hotter and more pressure as you go down. It reverses.

DW: Do you think that these areas that are deep under the earth that actually have vegetation and their own parallel evolution of a biome of animals and plants and so on-- do you think this is evidence of intelligent design? Doesn't it seem like the planet is rigged to have intelligent life that can live on the surface and then maybe more advanced intelligent life that can live underneath to supervise while being undetected?

CG: Life springs up wherever life can.

DW: Even in such a complex form as a whole biome, you're saying?

CG: Right, even in interstellar space.

DW: Right, we talked about before, the Solar Warden people analyzing these plasma beings out there. OK, so let's walk through now how the Germans got up to the moon. We kind of covered this a little bit last time, but you said that the super federation meetings that you talked about, there were 22 genetic programs that are being run on humanity, part of which involves the sharing and splicing of genetic material. You also mentioned that we're programmed to seek out and worship god-like like figures and to transfer our power to gurus and leaders and politicians, that kind of thing?

CG: Correct.

DW: And these people that run this super federation, I think you said there's 40 that are normally like the main ones?

CG: 40 to 60.

DW: Is it always the same delegates that they send to these conferences or does it rotate?

CG: It's usually the same ET delegates. The Earth delegation rotates.

DW: So **Corey**, we're going to have to devote whole episodes to what happened with the building out of the moon, what happened with the building out of Mars. But for the viewer, it's going to be a really difficult thing for them to understand how Germany, which was really the main industrial engine behind World War I and World War II-- they were arguably the great industrial power of Europe. And then America became their main counterpart in this boxing match that created World War I and World War II. That very strong industrial power seems to have been crushed. When we see the aftermath of World War II, the Germans had to pay enormous reconstruction settlements, financial settlements, that

essentially bankrupted their economy, just like what happened after World War I where you got the Weimar Republic, and people have a wheelbarrow of money just to go buy a loaf of bread. So look, Germany seems to have been flattened out and had nothing left.

CG: Well, at this point, Germany had already been abandoned by the German breakaway civilization.

DW: Really? When did that start to happen?

CG: It started to happen well before the end of the war. They saw the writing on the wall. The war was going to go badly. They knew it. So they started, as we discussed, creating enclaves in South America, in Brazil, and then down in Antarctica.

DW: So this was all in preparation for them losing. What were they wanting to do if they lost?

CG: They just wanted to continue their breakaway civilization, just continue and leave all the regular people behind.

DW: Is the apparatus that's developing the breakaway civilization in its own separate compartment, different from the government apparatus that's actually fighting the war?

CG: Yes, they were totally separate by this time.

DW: Really? I think that's a widely misunderstood concept, what you're saying there.

CG: Yes. So what had happened is in Operation Paperclip, America had obtained quite a bit more scientists than as advertised.

DW: What is Operation Paperclip, for those who don't know?

CG: Operation Paperclip is an agreement to where we obtained German scientists and technology that was highly advanced, and these people were like 20, 30 years ahead of us technologically, is what they say on paper. So we brought them in, and after the war we took these German scientists and put them into our fledgling space programs, into our infrastructure, and started giving them quite a bit of power as they started proving themselves as valuable assets.

DW: Why in the world we trust them?

CG: They were making us money.

DW: Doesn't seem like a good idea.

CG: Well, it wasn't. So what we had in 1947 was our intelligence agencies had discovered that the breakaway German groups had created enclaves in South America and Antarctica. And we knew that in Antarctica, it was a very large military base. So what the DOD had decided was to send a very large fleet under the command of Admiral Byrd. And this was called Operation High Jump, which many people were familiar with the name of that operation. I can't remember the exact number, but it was a war fleet.

DW: Battleships, destroyers?

CG: Battleships, destroyers, aircraft carriers, submarines, whole nine yards.

DW: This is after World War II, though. You said 1947?

CG: 1947, yeah. And they made it all the way down to Antarctica. And they ended up running into quite a bit of high technology that they didn't expect. There were these highly advanced aircraft that were coming up out of the water and from mainland Antarctica that were shooting down their craft and causing major damage on, I think, several destroyers. And their lives were lost. They really had their rear ends handed to them.

DW: Shooting them down with rockets or machine guns?

CG: Advanced weaponry.

DW: Really?

CG: Right. Energetic weaponry of some sort.

DW: Wow. How destructive were these weapons? What would happen if they fired one?

CG: It was destructive enough to get the job done. So they turned around, retreated, came back, and Admiral Byrd went before the DOD and the President, the Joint Chiefs, and gave a closed report about what he ran into. And his log is still the captain's log. It's still under lock and key to this day. Some of his comments made it out into the public realm to where he said, the next war, we will be attacked by aircraft that will fly pole to pole in a matter of minutes. A couple little comments got out like that from him. But this caused the DOD and the intelligence agencies to go to the Paper Clip scientists.

DW: But wait a minute. I was a geek, and I've read like 300 books on Atlantis and all this. And they say that Admiral Byrd saw the flat Earth, that there were mammoths and cavemen.

CG: That's a bunch of stuff that came out later that has nothing to do with the actual mission that he was on.

DW: Was it disinformation? Was it planted disinformation?

CG: It was either disinformation or somebody with a large imagination. I don't know which.

DW: OK.

CG: But they ended up getting in contact with some of these Paper Clip German scientists and asked about it. And some of them came clean and said, yes, we know about this group. And they said-- they being the Americans-- American intelligence and government, said, well, can you get us in contact with them? So these Paper Clip scientists started a dialogue between the Americans. And then I believe it was Truman.

DW: Did they do this over radio communications, some sort of encrypted communication?

CG: Well, it started out radio communications. And they arranged for a meeting between Truman and this breakaway group.

DW: No kidding?

CG: And this breakaway group started making some pretty heavy demands that Truman didn't like.

DW: So if High Jump is 1947, what are we now talking in time?

CG: Immediately after that.

DW: Really?

CG: Yeah. So after that, there was a period of contention. The German breakaway civilization found out through the Paper Clip Germans that after Roswell and a couple other previous crashes from extraterrestrial craft, that we had created a policy that it was top secret above nuclear weapons, that the existence of extraterrestrials and certain technologies was never to be released to mankind. And it was because it would destroy society and all of that. That was their reasoning. So the German breakaway

group down in Antarctica took advantage of this and pretty much started doing sorties over the United States. And this includes the 1952 flyovers of Washington, DC, that were two weeks apart.

DW: I always had thought that was extraterrestrials. They flew right over the Congress.

CG: That was the German breakaway group. And that was their way of saying, agree to our terms, sign a treaty with us, or we're going to break this wide open, and we know that that is your worst nightmare. You don't want the American people knowing anything about this.

DW: Or they'd lose control of the oil. So they'd lose their money. They'd lose the economy.

CG: Exactly.

DW: They'd lose political credibility.

CG: Mm-hmm.

DW: Wow. So it's the offer they couldn't refuse.

CG: Right. So this was happening at the end of Truman's time and at the beginning of Eisenhower's time in office.

DW: At this point, did the President of the United States still actually have the final say-so on the military and what they were doing?

CG: Yes, he still had quite a bit of power. And Eisenhower and Truman were the ones that signed treaties with this group.

DW: Wow.

CG: And what this did, is this brought the German breakaway group here to the US. Now, both groups had an agenda. The Americans had a plan that when the German breakaway group got here, we were going to infiltrate them, get their technology, find a way to defeat them, to use clean language, and then come out the winner.

Well, the German breakaway group had exactly the same plan. They wanted to build out the infrastructure in deep space, or in our solar system, and who better to do that than the United States?

Because we had defeated them with our industrial might. I mean, that is what defeated them. We built more tanks. We built more bombs. It was attrition that caused them to lose the war.

DW: Did this German group get out with gold? Like did they have their own source of funding that they could use if they had potential labor pools to activate?

CG: Yeah, they had lots of gold and plunder that they had.

DW: But they need workers. They need actual industrial infrastructure.

CG: They need industrial infrastructure, and they needed access to our corporations which signed the checks, and created the business plans, and helped build out the infrastructure. So what happened is they basically won the little competition of who would infiltrate who. They completely infiltrated the military industrial complex.

DW: Completely infiltrated?

CG: Completely.

DW: That's a very provocative statement. How do you define completely infiltrated?

CG: Well, they had already had a pretty good foothold with the German Paper Clip scientists. And when they came in with all this high technology, the fat-cat businessmen didn't care who they were. They didn't care if they were German breakaway groups. They didn't care what patch was on their shoulder. These banker fat cats and big-company bigwigs just had dollar signs in their eyes.

DW: They want the best toys on the block.

CG: That's right. So they with open arms accepted these German groups. And they got onto their boards. They totally infiltrated.

DW: What did the Germans show them to convince them? Did they get any tours? Did they get to see this stuff in Antarctica, anything like that?

CG: No, they handed over some of the ARVs, craft, to let us back-engineer while they were still playing us. And this was really the root behind Eisenhower's farewell address about the military industrial complex.

DW: His warning about the rise of unwarranted power and influence by the military industrial complex.

CG: Yes. And by the end of the '50s, early '60s, they had completely infiltrated, also, the intelligence agencies. And then after that, they finally had taken over basically the US government.

DW: That's a lot to take in.

CG: It is.

DW: I think everybody, especially people who are sports-minded, want to be on the winning team. And if you are on a team that didn't win, you feel as if you're a failure. I think you're going to encounter a lot of resistance because people don't want to be a failure. They want to believe in God and country, mom and apple pie, white picket fence, SUV in the driveway, and 2.5 children. What you're saying completely violates the idea of America as we know it.

CG: And that's what's going on at the top. Everybody down at the lower level, we still have that illusion. We still have the white-picket fence. We still have the SUVs in the driveway. So we've been able to maintain that illusion.

DW: Are there still people in the US military who believe in the Constitution that they swore an oath to?

CG: Absolutely. Yes.

DW: So this could cause a problem, then, if the corporations, the defense contractors are cutting a deal with the Germans. Not everybody is going to really want to dance in lockstep with Germany.

CG: Yes, and we can get into this later about the contention in the government, in the Earth alliances, and what's going on there. The Germans, once they had a firm grip on the infrastructure of the United States, that is when the massive buildout started to begin in space and the secret space programs. And they started working together with American cabal groups that had pretty much been working together the whole time, during World War I and World War II anyway. So at that point, that's when they started to build out the secret space program in earnest and the massive infrastructure that I'm talking about.

DW: So you said High Jump 1947, Truman starts to meet with them right after High Jump. Negotiations start to take place, but it's not going well. And then the Germans pushed the envelope by

making this very blatant public UFO sighting that, if it happened now with everybody's little camera phone, it would be the end of the UFO cover-up.

CG: Right.

DW: Right over the capital, right over the government building of the United States of America. That's 1952 you said. What's the timeline? Sketch it out for us of when did this translate. Did they immediately surrender after that over-flight? Was that like the final uncle, uncle, uncle thing?

CG: That was the straw that broke the camel's back to where the presidential advisors said, OK, we need to sign a treaty. When we sign the treaty, we will also come up with a plan to go ahead, and try to infiltrate, and steal their technology, and deal with them at a later time. We won't try to deal from weakness. And that pretty much brings us up to date to where we got to - where they started to build out the main infrastructure of the Secret Space Program.

DW: Now, that obviously is going to take manpower. How do they get the muscle? This is another thing I think people have such trouble with. And we only have a few minutes left, two or three minutes left.

CG: That's going to get us to something a lot of people have heard a little bit about which has been called the Brain Drain that occurred in the '50s, '60s, and on through the '80s of a lot of top scientists across the world being approached and made offers to join these programs. And there was all of a sudden all these brilliant scientists that disappeared off the face of the Earth.

DW: You say a lot of scientists and all these brilliant-- what is "a lot" and "all these?"

CG: There were millions of people over a long period of time that were brilliant and showed a lot of promise that they felt could contribute to this space program that was growing as the infrastructure group. And they brought these people in to be a part of it.

DW: Well, my insider, **Pete** Peterson, an old-timer, of course, said that it was 50 to 60 million people in the Brain Drain.

CG: That's a lot.

DW: And are they assigned to have children really quickly once they grow of age?

CG: Yeah, they're told to be fruitful and multiply.

DW: So 60 million people who have kids as soon as they get to be old enough to do that, you could be talking about a population as large as everyone in the United States or more.

CG: Right.

DW: Wow. We're going to be continuing this narrative forward, finding out more about what happened. How did we get these people up into space? What were they told? There's a lot more coming up ahead here. So I thank you for watching and stay tuned.

Cosmic Disclosure: Raiders of Lost Technology

Season 2, Episode 5

DW: Hello, I'm **David Wilcock**, and welcome to another episode of "[Cosmic Disclosure](#)" because you need to know. In this episode, we are going to pick up where we left off with this remarkable insider who we have the privilege and pleasure of speaking to, none other than **Corey Goode**, who is claiming to have worked in something we are calling the Secret Space Program. This would be the military-industrial complex industrializing and building out colonies in our solar system and beyond.

And it is a fascinating story because it lines up with information that I have received from insiders that I have been in contact with for the better part of 20 years. Most of these people never came forward. I withheld the information from the internet, and that makes it very easy to tell when someone else comes along who is speaking about the same things that I'd already heard. And I'm very delighted to have the opportunity now, to finally be able to talk about so many things that were not allowed to be spoken of before and have **Corey** here for the show. So, **Corey**, thanks for being here, buddy.

CG: Thank you.

DW: We talked about Operation High Jump. We talked about the effort that was made to try to bust up a German cell in Antarctica and that they encountered some pretty stiff resistance there. So I guess to start this off, what was the first method that they used to achieve space flight?

CG: In the beginning, they had success with their own engineers developing technology from their own engineering feats, as well as they had been scouring the East for ancient texts that they had been told

about and channelings from what they were led to believe, or what could be off-world beings, that some of the esoteric German secret society groups were dabbling in. And this led some of the other secret society groups to go on expeditions looking for these ancient, Eastern texts.

DW: Where did they believe these texts were located? Were there are a variety of locations?

CG: A variety of locations, these being in the Tibetan areas, the areas of India. A lot of people have heard the stories of ancient flying devices that had very advanced weaponry.

DW: The Vimana.

CG: Yeah, the Vimana, and it read like science fiction but was many tens of thousands of years old. And Western scholars wrote it off as fiction, science fiction, ahead of its time. These German groups, they believed more in the marriage of science and esoteric beliefs, and they decided that they would follow these leads that they had received through channelings and go and locate these texts.

DW: Did the beings that were doing the channeling give them specific coordinates of where these texts would be located?

CG: Yes.

DW: Really?

CG: They told them that they were under certain mountain ranges in certain areas that had at one time been a part of a more advanced civilization, had been forgotten by modern man, that a lot of the religious caste monks knew about it and had guarded it as part of their secret teachings.

DW: You and I spoke in previous episodes at quite some length about these Agarthans, and you said it was a group that was blonde Nordics that were living inside the Earth.

CG: Some of them, yeah.

DW: Some of them live inside the Earth.

CG: Some of them were blonde Nordics.

DW: Oh, and you said that the Germans preferred to work with them over the Draco, reptilian types.

CG: Correct.

DW: So why would the Agarthans-- I'm assuming, first of all, the Agarthans are the ones that were channeling through these secret societies, or is that not true?

CG: That's a hard one to speculate on because they, Orrick and these different groups, seem to have been in contact with several different groups.

DW: Several different ET groups?

CG: Extraterrestrial groups and also ancient Earth breakaway groups, so it's hard to pinpoint which information came from which groups. Back in the late '30s, I believe it was, they were asked to draw a picture of who they were communicating with. And the drawing of the head and the facial features of this being--

DW: It's a creepy-looking face.

CG: Yes-- and had very interesting, similar characteristics to Grays.

DW: Yes, it does, but the eyes aren't as big. But the head is really large, and then it's got this tiny, little chin.

CG: Right, but the Germans were led to go out to the Himalayan mountain areas to go on massive expeditions out east to recover these documents and to do so in a not-so-ethical way. They were going to these villages and these monasteries and, basically at gunpoint, taking these scrolls and books and taking them back to Germany.

DW: Are you saying that the texts that were in question were located in Tibetan Buddhist type monasteries?

CG: Mm-hmm, a lot of them are, and a lot of them were also in cave systems that these texts had been put in them. And they had been sealed in mountains.

DW: In the event that they got into one of these cave systems, would there be indications that what they were looking at was a remnant of an advanced civilization beyond just finding a cache of documents?

CG: Well, directly from what I read and the smart glass pads, these were wooden, similar to bookshelves but were lined with tons of scrolls and bound books. And a lot of them had medicine type

of information, I mean, all different types of, I guess, secret teachings and secret medicines and secret technology information.

DW: Were these natural caverns, or did it have some of that sort of smoothing out feature like you get with the Ancient Builder race stuff you talked about before?

CG: These were natural caverns.

DW: Natural caverns.

CG: Yes, and when these certain books were spirited away back to Germany, when they opened them and began to look at them, the German engineers were shocked to see that these were technological blueprints.

DW: When you say scroll though, my visual would be that we're looking at some aged, crumbling piece of browning paper.

CG: Well, some of them were scrolls. Some of them were actually bound books.

DW: Like a leather bound?

CG: Yeah, like leather, animal-skin-bound books. These are more of scribed texts and books that were handed down over generations. People would scribe them exactly as the other text was, and then at a certain point they were sealed away or put into a monastery.

DW: So we're not talking about books where the pages are made of like a Kevlar, indestructible material.

CG: No.

DW: It's just paper.

CG: Right.

DW: So what did these technical diagrams-- when you say blueprints, was it like the power system for the craft? What was the illustration of?

CG: Much of it they had to decipher over time, but it was the beginning of the electrogravitic craft that later on the West called alien reproduction vehicles. What they were, were mercury-spinning, mercury-

vortex-driven vehicles that created electrogravitic lift. And it was very simple concepts but very complicated concepts at the same time. And once the German scientists got a hold of it and married it with what they were already working on, they were able to jump leaps and bounds ahead of where they were in a short period of time.

DW: Was there a familiarity to the language of the book, or did they have to actually learn the language?

CG: That was one of the largest hurdles to get over, and they brought some very uncooperative, I guess you would say, volunteers from that region back with them to help them in the deciphering of the texts.

DW: Are you saying Tibetans?

CG: Well, Tibetans and people that were guarding the knowledge.

DW: Oh, wow.

CG: And they used these people to help them translate as much of it as they could. A lot of this stuff, these people had been scribing for generations, but even they had lost the original meaning of what they were transcribing.

DW: So the books had been copied over.

CG: Many, many, many times.

DW: And the blueprints and diagrams.

CG: But the Germans were very intelligent, very resourceful, and they were able to use these diagrams, create their own experiments, and figure it out.

DW: Some people are going to be questioning what groups we're talking about. There's like a Thule Society, T-H-U-L-E. Would that be one of them?

CG: The Thule Society, the Order of the Black Sun, the Vril Society, and there are about a handful of other different societies that are not really well known. And a lot of these ones that we mentioned worked together when it was logical to further their technological development and then would keep their own secrets. Some of them had much more advanced technology than the other societies.

DW: Were the members of the societies also in control of German industrial conglomerates like IG Farben, stuff like that, corporations?

CG: These groups were always in control of the money. They were always in control of the corporations. They were not always in control, totally, of the government.

DW: I see.

CG: They had infiltrated the government and were working in the government, but the government did not know what these societies and groups were doing. They knew what a lot of what the Order of Black Sun groups were doing because they were using military applications with a lot of the stuff they were developing for the war effort. But it was pretty well known that none of this technology was really going to be serviceable and ready to deploy by the end of the war.

DW: When we're describing this process of document acquisition that was going on, you mentioned India, and you mentioned Tibet. What are the years that we're talking about, and were there any other geographical regions besides Indian and Tibet where this was being done?

CG: China, yes.

DW: China, OK.

CG: China, India, Tibet, all of these modern ancient civilizations.

DW: Did it all cluster around the Himalayas and that part of the world?

CG: Yes.

DW: OK, and what were the years in question?

CG: 1918, 1919, but then the 1920s, '30s, it started exponentially growing, and most of it was in the 1930s and '40s. But most of it was heavily in the 1930s that they were really doing a lot of this work.

DW: I have heard from other scholars that one of the things that the Germans were looking for were pieces of material that they felt had esoteric power, like the spear that penetrated Jesus's body-- which they apparently were calling the Spear of Destiny, or something like the so-called Fountain of Youth, which most people think is a joke.

CG: That was another break-off group that the-- getting into, I guess, during World War II, the four-letter Nazi word, that group, they started sending them off looking for religious artifacts that had power. And they weren't just Judeo-Christian artifacts. They were looking for all sorts of ancient religious artifacts that they believed were rooted in either ancient breakaway technology, Earth breakaway technology, or ancient alien, ET, technology, some of which are the Ancient Builders race. They were wanting to get their hands on it for several reasons. Some of them believed that having possession of these materials, according to the legends, would ensure their victory. And also some of the ETs that they were in contact with wanted these technologies, especially the Ancient Builder race technologies. And that has gone up close to current era, until we figured out that some of what these tablets or stones that look like just relics, ancient stone relics that looked benign, we finally figured out that they were actually technologies that worked on a multi-dimensional level-- very, very advanced. And they were trading these off with ET groups for technology and for the ETs to come down and give material support.

DW: Now, if people are watching all the shows that I've been working on here at Gaiam, one of the things they will have seen is Disclosure episodes where I'm interviewing Graham Hancock. And we had, I believe, an entire episode just devoted to the Ark of the Covenant. And, of course, the classic Spielberg film, "Raiders of the Lost Ark," is about the Ark of the Covenant, that Harrison Ford's character is looking for the Ark. Did you encounter any information on your own that the Ark of the Covenant was real or that the German groups were looking for it?

CG: Well, according to the smart glass pads, there were three Ark of the Covenants.

DW: Three Arks of the Covenant? I hadn't heard that before.

CG: There were three of them, and they were devices that were housed in some sort of wood that was covered in gold as a shielding from the radiation. It's not exactly the radiation we think of, as in radioactive bombs. But even light bulbs, there is something radiating from them. So radiation can mean all sorts of things.

DW: Well, it's a very curious technology because when you read the Bible and talks about bringing down the walls of Jericho, it said that they had the Ark of the Covenant. They blew trumpets, and the bricks turned into liquid. The whole wall just liquefied and melted. So what kind of technology could do that?

CG: Sonic-- and not only that, but it was supposedly providing manna, food.

DW: Oh, food for them.

CG: Food for them, supposedly, you know, food, water, protection against their enemies, ways to defeat their enemies, supposedly a radio to God. So it was a multi-purpose device.

DW: And were these German esoteric groups aware that there were three of them?

CG: I believe one of them was destroyed, and there are two that are still present on the surface of the Earth.

DW: When you look at the Tibetan stories and you compare them with other records, in Tibet, they have this thing called the double dorje, which you hold in your hand. And it looks like a weird, energetic coil, and it seems to have been modelled off of a technology. When we go into the Greek mythology, we have Zeus' thunderbolt, which appears to be some device that he holds in his hand, can generate lightning.

We have Thor's hammer, which is the same thing. We have Poseidon's spear, which is the same thing. Were there particle-beam weapons or some type of energy weapons that you could hold in your hand like a gun that these German groups were also trying to locate in these expeditions?

CG: Yes, they believed very much that all of these descriptions of the gods were actual weapons, technological weapons, and they were looking for them.

DW: Yeah, another one that comes out of India is Vajra's spear. It's the same kind of idea. He's holding it in his hand, and it does incredibly powerful things.

CG: Right, so they were looking for all of these things. And a lot of these beings that had these weapons that were being written about, some were ETs, and some were extremely advanced, human, breakaway civilizations and presented themselves to the surface population as gods and did so for some time. As we became more sophisticated, so did their deceptive techniques. And in more recent times, they've been presenting themselves as extraterrestrials that are benevolent and here to save the world.

DW: Getting back to something you said before, do you think that the Germans could have acquired something like Zeus's thunderbolt or Vajra's spear and been able to engineer it into the building of their craft so they had an effective weapon?

CG: I think that there were quite a bit of technologies that were acquired and integrated into their breakaway secret space program that they were developing, but they were developing this for their own breakaway civilization and when it came down to it, did not care about World War II, the motherland, and using this technology to defeat the United States and the enemies of Germany that they were engaged in war with.

DW: When we see giant stone structures, like stone circles or single slabs, like menhirs or pyramids, that kind of thing, obviously, we can't work that kind of stone now in any effective way. Did the Germans find any technology that would allow you to, like, maybe hold onto a thing with your hands and zap a stone and allow it to levitate? Did they find anything like that?

CG: A lot of this type of technology was discovered, and it was discovered below the surface of the Earth, deep in cavernous areas in what has become known as the Honeycomb Earth that a lot of people refer to as Inner Earth or the Hollow Earth. And a lot of this was technology left behind by the Ancient Builder race and also by ancient ETs and ancient breakaway groups that had moved on and left certain technologies behind.

DW: I'm just curious because this is correlating with something I heard. The first insider I ever met had worked-- apparently, his godfather was one of the top 90 Cabal people. And he had described a technology that was based on crystals, and it actually was like a six gun.

And you had six crystals in it in kind of a cylinder. And you'd pop them in, and you could rotate to each crystal depending on the size of the stone. And it would actually beam into the stone, and that would help it to levitate. I'm just wondering if you'd ever seen anything like that?

CG: I've seen an incredible amount of technology that is based on crystals, and a lot of it goes way back to the Ancient Builder race. And a lot of it has been developed by much younger, Earth-based ancient races and ET races.

DW: Very good, all right, well, we're going to continue this really fascinating discussion. It's interesting to get correlations and hear things from his perspective, given his background. So when we come back next time, we're going to take this discussion of the German societies forward, and we're going to finally bring them out into space and start talking in very practical terms about where did they go, what did they find when they got there, and how did they build it out and make it their own?

That's coming up next time on "[Cosmic Disclosure](#)" because you need to know. I'm your host, [David Wilcock](#). This is **Corey Goode**, and we thank you for watching.

Cosmic Disclosure: We Were Never Alone

Season 2, Episode 6

DW: Hello. Welcome to "[Cosmic Disclosure](#)." I'm your host, [David Wilcock](#), and I'm here with the insider's insider, **Corey Goode**. What we're learning is that the effectiveness of this whole conspiracy comes out of the fact that it was all orchestrated by groups that were extremely secretive from the very get-go. And specifically, we've been talking about German esoteric societies.

So **Corey**, let's talk about that for a moment. What would happen in one of these German societies? How do they make sure that somebody is not going to squeal?

CG: That was woven into the fabric of the secret society itself. These people were very loyal. They were raised in it from childhood. And that was their way of life. Everyone else was an outsider. Everyone inside were the team, the family. So going outside to squeal, I mean, why would that occur to them?

DW: Let's say 1930s, as Germany is rising to become another great industrial power, somebody says, I can't handle this anymore. I'm tired of this. I'm out of here. What would happen to that person?

CG: Very similar as to what would happen to one of Al Capone's men that had a similar epiphany and change of heart. They would end up pushing up daisies, I guess, as they would say back then.

DW: So the point is people are not apt to want to talk at all. So you have an esoteric order. And you said last time they have great physical power. They're controlling the money system and industry?

CG: And have for some time.

DW: How do they enforce loyalty? Do they have initiatic rights in which you have to swear to secrecy on pain of death, things like that?

CG: Well, there's the whole theater part of the esoteric belief systems and black magic and all that. But it always comes down to the carrot and the stick. And making someone wealthy while everyone else is standing in line for bread is a strong motivator. And if you have a family, you want to provide for them.

And you're made to feel special. You're made to feel as a part of something bigger, grander. You're born into something that is bigger than everything else in the world. All the other people are useless eaters. You are important. What you're doing is important to not just the useless eaters and humanity but to the future of the planet and to a very ancient plan that your order or society has been meticulously working on for many generations.

DW: Italy was a fascist nation in World War II that worked hand in glove on the same goals in the Axis with Germany's fascist government. I'm wondering if these German secret societies might have also spread into neighboring countries like Austria or Poland or Italy. Or were they truly just German-centric?

CG: You have to look way, way back into history, back into the pre-Christian eras back when these groups were different pagan tribes. And these groups-- this is what these societies come from, way back then.

DW: Like Celtic?

CG: Celtic and--

DW: Druids?

CG: Druids, all these different groups. They're very ancient.

DW: OK.

CG: And they see their roots going back very far. And they see it as they own all of that area, and just as clouds blow across the sky, dynasties change. But they remain, like the trees on the ground.

DW: Well, one of the things that puzzled me as a tangible data point that people can sink their teeth into, is I did research into ley lines. And you see things like Stonehenge and Avebury and Carnac in the northern province of France, ancient sites with giant stones and then modern sites, including German Gothic cathedrals, that are built on these same lines. So somebody knew to build these cathedrals and these sacred sites of worship and even government facilities on these lines. Would you say that might

be one tangible data point people could look at indicating that there was a secret knowledge that the public was not being told about behind where these sites were being constructed?

CG: Yes, these secret teachings go back many millennia and are highly guarded. And a lot of this information has found its way under the Vatican and the vaults. And the Jesuits and other groups still have access to it.

There are many other libraries of this sort around, especially Europe, that these secret societies have access to these ancient mystery school teachings. And these mystery school teachings have information going all the way back that have several different ancient languages in them that translate older and older texts. And it goes further and further back talking about technology, and technology of people and beings that come from the heavens.

DW: You've said before that breakaway civilization groups living inside the Earth contacted people on the surface and posed as gods.

CG: Still do.

DW: Were there in these European, Celtic, and Druidic societies, priests or nobility or royals who had a more technically involved and accurate contact with these breakaway civilizations?

CG: Yes. The priests of Odin and all these other groups, the priest cast in just about every one of these ancient civilizations, they guarded the secret teachings. They had access to these scrolls, these books, this information, all the mystery teachings. They kept the information from the kings, emperors. They kept the information from the commoners. And it is from them that a lot of these breakaway secret space programs and advanced technological, subterranean civilizations sprung from.

DW: Are there members of these subterranean civilizations or space-based civilizations who are the descendants of people that might have been pulled out from human life on Earth, maybe even as old as thousands of years ago or even, let's say, in medieval times? Has there been a continuing abduction of people from Earth into these various groups over time?

CG: Yes, and that is one of the reasons the Germans were so interested in all of this and they were so focused on the "master race," because some of these groups that were coming out from underground and presenting themselves to them as either ETs, depending on the time period, gods, and in some cases their forefathers, were a lot of times blonde-haired, blue-eyed, and very Caucasian, master-race

looking. The master race that was depicted by these groups during that late World War I, World War II era, they had very much that look about them.

DW: If people had been pulled from the Earth into these groups, did those groups interbreed with those people, or were they used as more like a slave caste?

CG: Well, they were more manipulating the surface.

DW: Oh.

CG: They were teaching them agriculture to have them provide agriculture as an offering to them. So with these groups, it was more about manipulating the surface population to have a return in what they considered an investment.

DW: Would you say that the priest caste you referred to in these Druidic and Celtic and other societies around the world, did they have access to space travel and portal technology?

CG: Some of them definitely did.

DW: Really? So there's been, to some degree, certain people on the surface of the Earth who have had access to space all throughout our history?

CG: Yes.

DW: That were people born on Earth from human parents on Earth.

CG: Yes. Yeah, I had read in the smart glass pads about the Spaniards chasing some of the Mayan priests that would run right up to a wall that had a door carved into a wall that went nowhere, and they would be holding a bunch of scrolls in their arms. And they would run up to the door, touch the door, and then walk into the rock, walk through the rock. So I mean, that was obviously some sort of portal situation.

DW: Well, I remember doing an episode on Ancient Aliens where we talked about this thing like you're describing, looked like a doorway, but it was just carved into the side of a rock wall. And there was almost an identical one in Turkey. Is Turkey another country that is really central in these breakaway groups based on its location near the Mediterranean Sea? Egypt?

CG: Yeah, Turkey is a mixture. There's a breakaway group there. And there's also an ET group that has settled there.

DW: Do we know anything about that ET group?

CG: Yes.

DW: You don't want to tell us?

CG: Well, it gets into some of the disturbing stuff. The groups that are the Sumerian god kind of groups.

DW: Oh, like Draco type, reptilian type?

CG: Yeah. They are more of the negative groups that are also down in South Africa right now, Marduk and different names that you would hear.

DW: What about the breakaway civilization in Turkey? Is that similar to the other ones, or is that a unique group?

CG: In Turkey mainly, there's quite a bit of ET activity going on down there. There's a breakaway group there, but they're more subservient to the ET group. Turkey is a very ancient area, and it's been controlled by a certain ET faction for a very long time.

DW: I've just been trying to map out some of the terrain here so we can understand how the Germans end up making their way out into space here. This was not the first time that humans from Earth had made it into space by any means based on what you're saying.

CG: Right.

DW: OK, you also said that these breakaway human civilizations in the Earth or outside the Earth were one of the groups that the Germans were channeling that were helping them find these scrolls that help them build craft. I guess what I'm concerned with is why wouldn't these extraterrestrial or breakaway Earth group people, why wouldn't they just give the Germans the technology they already had? Why were they trying to make the Germans go through this painstaking process of archaeological excavations and doing it themselves?

CG: Well, eventually they did start giving them more advanced technology. But they had to develop a certain amount themselves.

DW: Is that part of the esoteric rules they have to follow?

CG: I'm not sure. But they basically had to prove themselves as not only being able to have the engineering and scientific ability to create this technology and understand it, but once they got to a certain point, not only did the Draco group start to give them scientists to help them and give them technology, but also the breakaway Agarthan group did the same.

Now, the Draco, this Agarthan group don't necessarily get along all the time, and the Germans favored the Agarthan group. And they were getting a lot of very excellent and very, very unique technology from these groups. And they started using it to venture out past our atmosphere and go to the moon and study the asteroid belt.

And when they went to the moon, they learned very quickly that the moon was a pretty much hub for many other ET groups to meet in a neutral area to have bases to be a part of some grand experiment, which the Earth is a part of, to observe Earth and be close. And the Germans had traveled to the moon and had planned on starting colonies there and saw that it was pretty hostile to try to land any place around on the moon and start building. So they signed, just like we did later on, they signed agreements with the Draco and also these Agarthan groups.

DW: When you say "we," you mean the United States government?

CG: The United States government, yes.

DW: Signed a deal with the Draco?

CG: Well, the United States government signed deals with several groups. But the Draco were one of them, as were the Agarthans and others.

DW: I'm just curious, did they have any trouble getting outside the Earth when they tried to fly out of the Earth?

CG: Once they started flying around and approaching the moon, they started having some issues with resistance. And once they formed partnerships with these Draco, who had a very large portion area on the back side of the moon that they then fell, I guess, under their protection. And then they began to start at first trying to build their own moon bases and colonies-- that didn't go very well. Then they

started discovering these very ancient buildings, very ancient buildings. And they then found a way to pressurize these buildings and use them temporarily while they built a moderate German moon base.

DW: All right, there's a lot you just said that I think we need to untangle. First of all, I want to ask you a really stupid question. Is there a breathable atmosphere on the moon?

CG: No.

DW: Did they have some type of astronaut suit like what we see later with NASA astronauts to walk on the moon?

CG: Yes, they developed pressurized scuba-type rebreather suits.

DW: And you said that they made early attempts to build on their own that were not successful?

CG: Several-- many attempts.

DW: Did they try to bring native materials from Earth? Or did they try to build with local materials they found on the moon? What was the attempt?

CG: They would bring some materials from Earth, and then they would try to build out of the local material, create concretes with the concrete building technology that we used on Earth. And they tried several different techniques. They had quite a few problems.

There was one group that was involved with a reptilian reptoid group-- a project that was traveling not through spacecraft, but through portals to the moon and apparently back to a different time period on the moon and were building above-ground facilities. And these at some point were abandoned. And later on, the Secret Space Program were finding these very ancient buildings with Nazi insignias and symbols and eagles with swastikas in them.

DW: You said very ancient?

CG: Yes.

DW: What do you mean by very, like 2000 years old?

CG: Many thousands of years.

DW: Many thousands?

CG: Yes. There's a temporal technology that the Secret Space Program uses that is kind of like carbon-14 dating, but it reads a temporal signature of a building that is constructed.

DW: Temporal meaning time?

CG: Time.

DW: Time signature?

CG: To be able to tell approximately how old it is. And I don't recall exactly how old they were, but they were thousands of years old.

DW: So this technology is able to tell when material was last disrupted?

CG: Right, when it was--

DW: Or when it was constructed.

CG: --manipulated.

DW: So these were highly decrepit buildings? They were breaking down?

CG: Dilapidated and falling apart.

DW: So this is an extraterrestrial technology that they had access to that allowed them to portal back into the past?

CG: Right. This was a joint operation with reptoids.

DW: You also said to me in private conversation that when they started to build on various locations that they found explosive charges had already been planted underneath the locations.

CG: That was the Secret Space Program. When we would go to build outposts, mainly security outposts-- and I described how we built those out of local and materials brought from home, giant kevlar bags, they would fill it with the local soil and build up a structure. I've written about it. It's a whole long process. But the engineers that were there that were using some of this temporal technology for surveying of the land discovered that underneath where they were building there were charges that had been placed there and that somehow someone had figured out that someday someone's going to build some sort of facility there and had placed charges there thousands of years ago.

DW: Wow.

CG: And so they found a way to remove them.

DW: You said that one of the first things that the Germans did when they went into space was they went to the asteroid belt.

CG: Yes.

DW: Did they see anything that would be considered strange or unusual by our normal, terrestrial standards when they went to that area?

CG: Yes, they found signs that it had already been mined for quite some time.

DW: Really?

CG: That this had obviously been another planet at one point and very small remnants of Ancient Builder Race technology were found embedded in some of the asteroids.

DW: What would a very small remnant of ancient builder race technology look like?

CG: Just pieces of their technology, small remnants here and there that they would find.

DW: Well, you had described before that it's going to look like just stone that's very nicely carved, that kind of stuff?

CG: Yeah, something that you would find, it would look like a piece of a diorite or very hard stone that was shaped in a very unique and pleasing way to the eye to where you would think an ancient culture had carved it and maybe it was an altar or, the way we think, it had some primitive use. When in reality, it was a very extremely advanced, multi-dimensional device, and there were many, many asteroids that-- there had been mining activities going on for millennia in the asteroid belt.

DW: And this was something that was very clearly able to be seen, like strip mining lines, that kind of thing?

CG: Yes, big holes in the asteroids with built-out areas for docking, for resupply vessels and pickup vessels for picking up the raw materials.

DW: Did they ever find smashed spaceships that had been destroyed by weapons fire that were just kind of tumbling end over end in the asteroids, anything like that?

CG: Most of what I remember them finding was on the moon after some of the ancient battles.

DW: Were they able to find ruined ancient craft and gain something from them, like debris from a technological flying craft?

CG: Yeah, that was found on Earth, on the moon, on Mars. It's been found all over the place.

DW: Wow. So you can't breathe on the moon. So they have these space suits. And you said they were fascinated to find Nazi insignia on ancient buildings.

CG: Yeah, completely stripped buildings and dilapidated buildings with the eagles with the talons holding swastikas and German writing, German script, but anything of value or useful, it was all stripped.

DW: So you had said that there was a Draco area on the moon, that they had a large tract of land. And you had said in previous episodes--

CG: This was on the Draco area.

DW: OK. Did the Draco provide material assistance to them, or were they more just allowed to develop the land on their own?

CG: Both.

DW: OK. So at what point did the Draco become involved in the building process, if you said that these early building attempts they made were unsuccessful?

CG: They finally built a successful, small base--

DW: "They" the Germans?

CG: Germans built a small base and used that as a jumping-off point. And then they successfully built a base on Mars as well. The Draco did not assist them in all of this. There was a separate base on the moon that is a joint base that the Draco and the human German breakaway groups use still to this

present day. And it is a heavy Dark Fleet base. And it is shaped kind of like a pyramid with the top cut off, or what would you call that shape?

DW: Trapezoid?

CG: Yeah, trapezoid.

DW: Do you know when that base was constructed?

CG: This would have been in the '60s, early '70s.

DW: Did the Draco have their own buildings in this tract that they owned on the moon before?

CG: Under.

DW: Oh, underground.

CG: Mm-hmm, under the moon.

DW: So their effort to help the Germans build their own facility was more just kind of letting them have their own territory, feel safe, feel like they got their own home?

CG: Well, it was a part of a wider plan of integrating them all together in this control system over the Earth that the Draco is very much involved in.

DW: There are movies like "Iron Sky" talking about stuff like this with Nazi base on the moon.

CG: I had so many comments on that. I finally went and saw that ridiculous movie.

DW: Yeah? Did they build the building in the shape of a swastika?

CG: It was in a shape of a swastika originally, but now that building is now the lunar operation command, and that has been built out and built over. That is an old and very small part of what is now the lunar operation command that the overall Earth secret space programs use on a regular basis. The trapezoid-shaped moon base is off limits to everybody except for the Draco allied human groups and the Draco.

DW: Did the Agarthans have any material support or logistical support in the colonization of the moon early along? Or did they kind of back off from that aspect of it?

CG: They backed off from that aspect of it, but they do have a presence on the moon.

DW: So this is "[Cosmic Disclosure](#)." I'm your host, [David Wilcock](#). We are exploring very fascinating information, and that's going to continue next time. So as always, I thank you for watching.

Cosmic Disclosure: Remnants Of Ancient Mars

Season 2, Episode 7

DW: Welcome to "[Cosmic Disclosure](#)." I'm your host, [David Wilcock](#). And in this episode, we're going to be getting into the Germans traveling to Mars. However, in between episodes, it occurred to me that there are some really important unanswered questions.

One of these questions is that we have artifacts on the moon, and there are also artifacts on Mars. So we're going to get into the relationship between these ancient artifacts on the moon and on Mars, since the Germans ultimately found them on both spheres. This will help us to build our way into understanding what the Germans actually did on Mars. So all of that will be covered in this one episode. So, **Corey**, I'm really excited to get into this, and thanks for being on the show.

CG: Thank you.

DW: So, **Corey**, we were talking about the German development of the moon in the previous episode. How do you feel that this was accomplished in light of the Ancient Builder race? Were there Ancient Builder race ruins on the moon that they were able to find when they were doing that research when they first got there?

CG: Yes. There are Ancient Builder race ruins all over the entire solar system and underneath the surface of our planet.

DW: What specific Ancient Builder race ruins did they find on the moon?

CG: I think some of the most significant ones that you would be interested in, and a lot of others, are some of the ancient buildings that were obviously built for a race of very tall beings, unless they were beings that just liked a lot of headroom and really tall arches and doorways.

DW: When you say really tall, what are we talking in feet, like what was the estimated height of these people?

CG: Some of the stone seats and the doorways, we're talking upwards 60, 70, 80 feet.

DW: Beings 60, 70, 80 feet tall?

CG: Tall.

DW: When you say stone seats, what would they look like? Would there be anything that we could see on Earth that would be similar?

CG: They called them thrones, but they were not. There were lines of seatings along walls that were facing outward, that I guess the closest that we would see in an older castle would be like a throne room with thrones against a wall.

DW: Were these seats carved just as very utilitarian and basic? Or did they have sort of ornate designs to them? What was the aesthetic of the seats?

CG: They at one time had writing or emblems on them and symbols on them, but someone for some reason had sandblasted or removed them, same with any other area in these buildings and structures that seemed to have had any type of indication of writing characters or images. They were erased, as if-- I guess they say the victor always writes the history. Well, maybe other ET groups moved in millennia later and decided, we want to write the history, we want to be known as the gods. So they erased what was written.

DW: Did these thrones just appear etched into the side of a mountain, like we might see with Mount Rushmore on Earth? Or were they inside rooms of some kind?

CG: They were inside rooms. And this was very high tech. It was obviously manipulated matter, technologically manipulated matter.

DW: So describe for us-- how would you find a room? Do you see like a dome, and then you go into the dome? Is it built into the side of a mountain? Is it underground? Where do you actually see these rooms? How do you get into a room?

CG: These are mostly covered structures now by moon dust and meteors that have hit and left remnants. They've been there a long time. But there would have to be a certain amount dug out. Maybe

10% would be above the surface. And even that would have to be uncovered. And the rest would have to be dug out, and then they would go in and excavate and check out the interiors.

DW: Were these structures on both the Earth-facing and the dark side of the moon?

CG: All over.

DW: And so is the building often square? Or is it more of a circular type of shape? What was the shape "clue" that this was a site and not just another irregularity in the moon's surface?

CG: These buildings were found in all different shapes, all different conditions, and made out of different types of materials, including the before-discussed transparent alloy aluminum material, or parts of the buildings were made out of that material.

DW: So some of these buildings, the walls you could actually see right through them once you uncovered them from the lunar regolith?

CG: Right.

DW: Wow. Now, Richard Hoagland has talked extensively about what he believes to be glass domes that were on the moon and the idea that it could be pressurized inside, and you could have plants and trees in there. Did you encounter any evidence that there were, in fact, glass domes?

CG: There are all sorts of glass structures that are mainly destroyed.

DW: Including domes?

CG: Including domes and towers.

DW: And when you say destroyed, by whom?

CG: It may be by what, by a cataclysm. A lot of stuff is left on the moon as a reminder of a great war. There is quite a bit of other material and items that are left that come from much longer ago. The oceans of time we're talking about here are mind-boggling. And the number of different groups and races that have contributed to the trinkets and the buildings that are on the surface is just as mind-boggling.

DW: Let's talk about the parallels between whatever was found on the moon and whatever was found on Mars. Because the German scientists, let's say-- because they're not all Nazis-- when they went to Mars, did they find similar structures as what we saw on the moon?

CG: Yes. These Ancient Builder races and other races that have come into our solar system through the ebb and flow of time and fought for control over the solar system, controlled, lost control, come back millennia later-- this has gone on for millennia-- their structures have been found all over the entire solar system. Our solar system is littered with ancient, ancient archaeological sites.

DW: You mentioned before that there's a big portal that goes to other galaxies. It's right outside our solar system.

CG: There's a portal system that is a part of the cosmic web, and our solar system is in a very coveted area. And yes, that portal system spreads out not only to other galaxies but other star systems within our own galaxy.

DW: So we're in like a real high-rent district.

CG: Yes.

DW: Would you say, then, that our solar system has a lot more colonization and history than most civilizations that would be in more of a country area, as opposed to an urbanized district like this?

CG: I've been told that we're basically an oasis on a cosmic silk road.

DW: NASA came out recently and suggested that Mars at one point had a 1 and 1/2 mile deep ocean that covered at least half of its surface like the northern hemisphere. That's NASA saying that. Why do you think they would say that?

CG: I think we're getting to a point in human consciousness to where it's becoming pretty ridiculous to try to hide what's in front of our face when we look at Mars. Plenty of people have taken satellite views of Earth, satellite images of Earth, satellite images of Mars, put them side by side and geologically proven and shown that they've had the same type of activity on them.

DW: So did you encounter information suggesting that Mars was more Earth-like at one time?

CG: Yes.

DW: You had mentioned before that the asteroid belt was a destroyed planet. Hoagland and others have done work suggesting that Mars was originally a moon of this planet. Did you encounter anything like that?

CG: According to the smart glass pad, that was the intelligence-- that Mars was at one time a satellite of a super Earth that existed now where we have an asteroid belt.

DW: Was Mars also a watery planet with oceans as well at that time?

CG: It had oceans and a very thick atmosphere that was blown off in the same event that changed its current orbit and created the asteroid belt.

DW: When you look at the work of certain astronomers such as Dr. Thomas Van Flandern, who have studied what he called the Exploding Planet Hypothesis, or EPH, we see half of Mars is totally covered with craters. The other half is really quite smooth. So do you think that that was asteroids from the planet exploding, hitting Mars? Did you encounter anything suggesting that's what happened?

CG: Yes. And we can go into this in quite a bit of detail. There was a lot. The surface of Mars, half of it, has heavy shocked quartz and deposits. And half of Mars is positively charged. The other half is negatively charged. And because of what had happened to it in this event, it is now a basically giant capacitor.

DW: Hmm. So we have this whole, huge planet that's a habitable world with oceans. And then there is a moon around it that became Mars, as we think of it, that was also habitable. Did you encounter any information suggesting that there were opposing civilizations on each of these spheres? Or was it all part of one greater civilization? Do we know that?

CG: I saw the nuts and bolts, scientific information. That's where we start getting into the secret Earth government syndicate, or Illuminati, religious ideas about all these ideas about what happened. They've created all kinds of myths and ideas about how it happened and what happened, and they believe it as fervently as any other person believes their religion.

DW: Now, you said a little earlier that these buildings on the moon, we were talking about thrones that you found on the moon with buildings, different types that were buried in the ground, and you said that there was some kind of effort to wipe off the writing and the insignias on them. Do we find similar structures like that on Mars?

CG: Yes, all over the solar system, and they've all been treated in the same manner.

DW: Did these structures appear to have been built when Mars still had oceans before it got this blast from the planet exploding?

CG: I am going off of memory here, and I don't want to get into speculation, but that seems right.

DW: How much architecture is on Mars? How much stuff is there to find that shows that there was an advanced civilization there?

CG: Most of it is either underground or really destroyed. The surface of Mars went through such a huge catastrophe. It looks like a shockwave went around and around the planet. The geology is all screwed up. It's just a big mess.

DW: Well, let's talk specifically now about Cydonia, which is the area that Richard Hoagland talked about with the face and what appears to be a five-sided pyramid nearby.

CG: I saw the pyramids.

DW: What do mean you saw the pyramids?

CG: I saw five-sided pyramids. I saw pyramids--

DW: But we've all seen pictures of that.

CG: I have flown over and saw the pyramids--

DW: Really?

CG: --that were partially buried with like mud or sludge. Either I did not fly over the area where the face was, or I didn't see it. I did not see a face.

DW: Are you seeing parts of the pyramids that still look like a stone-carved surface? Or was it all covered in some degree of debris?

CG: Part of it is sticking up out of the debris, but I would say most of it is-- they are quite a bit larger than people think because they are covered in sludge.

DW: I'm remembering one insider, Daniel, tell me that he saw a picture of astronauts waving next to a pyramid on Mars and that there was a very nice, sharp line of the pyramid going up. So it seems like you're kind of confirming that there would be certain pyramids where there are still some sharpness that could be visible from the ground.

CG: They were obviously pyramids.

DW: Wow. OK, so the Germans went to the moon, and you said they went to the asteroid belt, and they also went to Mars. So what is the sequence? Did they do all this at the same time? Or how did they approach this?

CG: Well, first they went to the moon. After a failed attempt, they set up their base on the moon. And then they went to Mars. And then they set up another temporary base on Mars when they built out a larger base on Mars.

DW: OK, so let's just pause there for a second. Germans get to Mars. We haven't had NASA go to Mars yet at this point in our history. What's the year that we're talking that they got there that you know of?

CG: This was all happening in the late '30s and early '40s.

DW: Did they look specifically for archaeology?

CG: I just know that they were looking for bases to create outside of the Earth, as well as bases in areas of the Earth that were inhospitable or out of the reach of the regular civilization of Earth.

DW: How did they have breathable air inside these craft? Was that part of extraterrestrial technology that they were given so that they could have a long trip and not need to come back here?

CG: Yeah, they had developed some of their super submarines. They had already begun to develop carbon dioxide scrubbers and closed-system oxygen-breathing systems. They had already started to develop that for some time. But it was after they had worked in development with these ET groups and developed advanced technology that not only gave them electrogravitic travel but also gave them the ability to have artificial gravity, and also have environmental controls that they felt comfortable leaving that far from Earth.

DW: Would they travel from the Earth to Mars? Or did they have a space station that they built somewhere between as like a supply depot?

CG: They traveled from the Earth to the moon, from the moon to Mars, just like we have planned to do.

DW: And what's the time of that trip? Like if you travel from the moon to Mars, how long would it take them based on that technology in the '30s?

CG: It would have been a matter of hours. I don't know exactly how long.

DW: And you say back then, as in now it would be faster?

CG: Now it's a matter of minutes.

DW: Wow. Let's say that they are looking from the surface of Mars now. Some researchers have said, and Hoagland is one of them, that the original Viking Lander photos seem to have had the red turned up in the image and that the sky does not actually look red, but it's actually blue like the Earth.

CG: Yes, they turned a red filter on. But you have to understand, there are times, depending on the-- it's very dynamic on Mars. There are times when the sky is red. There's so much dust in the air, especially if you're in the equatorial areas. The closer you get to the polar regions, the less atmospheric sand you have, debris you have. And there are aurora borealis.

You have a purplish pink sky depending on the time of day, sunset, sunrise. But during the day, there is kind of a purplish blue sky, but there is a lot of time when the sky, because of all the storms, is full of the red sand. And it's red.

DW: Could we breathe the air anywhere on Mars?

CG: It's not advisable to breathe it anywhere on Mars. In the northern and southern regions, it's easier to breathe. But it's more like being at the top of Mount Everest. Oxygen is thin. The barometric pressure is very, very, very thin. You do need a light duty, lightweight protective suit, and usually a respirator that is releasing some oxygen to you.

DW: Very interesting. You said before that the moon is heavily inhabited with a variety of different races. Are there satellites orbiting Mars or space platforms that have weapons' systems that will shoot you down if you try to go to that planet? How did the Germans-- did they just fly right in? Or did they encounter some resistance?

CG: I do not know if they encountered resistance. I believe at that point they had already formed an alliance. So I believe that people, or the group that they had formed an alliance with, would have been the people-- "people"-- that you would have to worry about shooting you down.

DW: Right.

CG: There are a couple small moons around Mars.

DW: Phobos and Deimos, yeah.

CG: And there are satellites, current era, like crazy around Mars.

DW: Really? Satellites built by modern humans, you're saying?

CG: Modern humans, modern humans that inhabit Mars.

DW: Really? People that were born on Earth that migrated to Mars and built those satellites? Is that what you're saying?

CG: People that may be descendants of people that were born on Earth.

DW: And you said it's filled with satellites?

CG: Yeah. There are plenty of satellites around Mars.

DW: Wow.

CG: And some of them are weapons' systems. And a lot of these are people that are descendants from some of the German groups that established early colonies on Mars that later on grew after the Germans co-opted the military-industrial complex of the United States. These colonies grew across the planet. And a lot of these people that are there now are descendants.

DW: I want to get back to that, but you mentioned Phobos and Deimos. People who've studied this information online and have really kind of gotten into Mars, it's kind of a commonly known thing that the moons are, I guess, too close to the planet and that they also move too quickly in their orbits. I guess some people, like Hoagland, have also said that it appears that they're hollow inside based on their signatures. So what are we looking at with Phobos and Deimos? Are they just moons? Or is there something else going on?

CG: Phobos is crushed, is a crushed sphere.

DW: Really? So it was originally a perfectly round sphere?

CG: It was at one time a sphere.

DW: Wow.

CG: And at one end, there's an opening.

DW: So they don't show us that from NASA? They just make sure they photoshop it out or something?

CG: I haven't really looked at the NASA images, but I know that NASA photoshops and airbrushes images at an unbelievable rate of Mars, the moon, and other planetoids. So I would imagine there are a lot of things about Phobos that they photoshop or make out of focus.

DW: Well, one of the weird things about it-- and I can see it perfectly in my mind, and we'll put it up on screen-- is Phobos has these very extensive, parallel, straight lines that are all in the same direction. And then there's others that are going 90 degrees.

CG: Yeah, they're like ridges.

DW: What do you think that is?

CG: Just like on the moon, our moon-- this gets into a whole other topic. Our moon is an artificial structure. On top of it are hundreds and hundreds of feet of regolith and just smashed meteor matter that have built up over many millennia. And Phobos has its own gravitational field, and it pulls debris on top of it. And underneath this debris is a super structure.

DW: Did the Germans show any initial interest in Phobos if there's a hole in it that you could fly into? Did they do that when they first got there?

CG: I did not see any record of them.

DW: What about Demos? You mentioned Phobos is a collapsed sphere, which I guess implies that there's a lot of hollowness inside. Is Demos also something other than just a regular moon?

CG: I did not read anything about it being artificial. So it's possible that it might be a natural object that was captured in a cataclysm that happened a long time ago.

DW: First of all, is there liquid water running on the surface now in certain places?

CG: Mars has a very strange cycle year, yearly cycle. At certain times, the water that is at the surface in the form of ice liquefies.

DW: Really?

CG: But not for long. I never saw information about lakes, small oceans in the current era. I never flew over bodies of water or saw bodies of water.

DW: OK. So did the Germans have a plan to try to use local materials to make a sustainable base when they got there? Was that always the intention?

CG: Yes. Just as on the moon, they planned to take a certain amount of resources to Mars, lime and all the different things they need to mix with local resources to make concrete and whatever they needed to build structures that they could then pressurize and use as temporary shelters. They had to make quite a few trips to bring people and materials over in the beginning. This was in the beginning of when they were using stargate or portal travel. And in this early era, they were using the portals to transport materials and not people or organics.

DW: Did they have trouble with the organics having damage, like to their life cycle?

CG: Yes, as in killing them in a very gruesome way.

DW: Right.

CG: Until they figured out the proper way to do it with help from some of these allied extraterrestrial groups.

DW: So what's the year that you know where portals started to be used to transport materials?

CG: They've been using portals to transport materials-- they've known how to do that since the '30s and '40s.

DW: Wow. So that's well before the Philadelphia Experiment.

CG: Right. And you saw how badly that went with the people.

DW: Absolutely.

CG: It wasn't until the '50s that they were able to start transporting people consistently without them suffering. I believe they called it temporal dementia. People would teleport intact from here to Mars. They would look fine, but then after a number of days, they would suffer some sort of dementia, they would call temporal dementia. And the Germans did a lot of work in this field that helped us figure out how to do this properly-- them working alongside their ET allies.

DW: It's such a mind-blowing thing to imagine that there were artifacts already there, like pyramids, when the Germans got there. How much were they interested in trying to reoccupy what was there, and how much were they just trying to build new stuff?

CG: In the beginning, it was getting a lay of the land. Just like we're doing, they were mapping out Mars, getting a lay of the land. They had quite a bit of data on the geography of Mars and these smart glass pads. And this was information that was presented on a smart glass pad that's very technical, but it came from like typed sheets of paper that I was seeing. So they didn't have a real high-tech way of showing this information.

DW: So the Germans originally didn't have these smart glass pads, as you said before, but the data that they came up with in their surveying you saw as these JPEGs, or whatever they are, of original, typewritten documents.

CG: Right. And some older photos from old 35-millimeter, or whatever they used, photographs.

DW: Were there photographs of cool-looking ruins from old civilizations that you saw?

CG: Yes, of ruins and of aerial photographs of areas, the huge volcano--

DW: Olympus Mons.

CG: Olympus Mons. There are lava tubes that are 10 times the size of the lava tubes we have here. And they are perfect for sealing and creating an environment on the inside. And you have an easy, ready-made base. And that is a very highly coveted area to create bases. And the Germans wanted it. Later the ICC groups, I guess the modern space program groups, wanted to utilize that area. But it was already occupied by another group. There were a lot of them, and they defended it fiercely.

DW: Really? Do we know anything about what they look like or where they're from?

CG: Yes. There's a treaty between some of these groups. One of the groups are a reptilian type, and the other are an insectoid type.

DW: That's kind of what I expect.

CG: That is a very coveted area.

DW: So when you say 10 times bigger than lava tubes on Earth, are we talking five miles wide, 20 miles wide, 50 miles wide, top to bottom?

CG: I mean, huge. I mean, they dwarf any of the caverns or the tubes that we have here.

DW: Most of which we don't know about, I guess you're saying.

CG: Right, yeah.

DW: Because they already have huge cities built in them.

CG: It has to do with the size of the volcano, the gravity, the barometric pressure on Mars, and the way that-- how come they're so huge.

DW: So could they be even like 100 or 200 miles long from top to bottom?

CG: I would be speculating. I didn't see any hard data on how many meters or yards or feet they were.

DW: But given that some of the cities here on Earth I guess can probably hold hundreds of thousands of people, you're saying that in these lava tubes, you could have millions of people.

CG: There are millions of beings living in these lava tubes.

DW: Wow. What are they doing?

CG: Just living out their life cycles there. They have their own civilization, their own way, their own societies. They're very territorial.

DW: Do they have pop stars? Is there like an insect Britney Spears?

[BOTH LAUGH]

CG: I don't know that much about them. A lot of the people that have been assigned to do security details on the surface of Mars have interacted with them. I have not interacted with them.

DW: So did the Germans get resistance from them right away when they first arrived?

CG: They interacted with them quite a bit.

DW: They tried to fight to get some of these tubes?

CG: Yes. Their plan was to go in and take some of these tubes. And there were some battles fought. And it did not go well for them at all. They even had some of their early bases destroyed. And they lost entire early bases.

DW: With the personnel, like all the people were killed?

CG: Yeah. And they also chose poorly. They built some of their bases towards the equator and found out that the dust storms that kick up quite often are very highly electrically charged. Static electricity builds up in all of the sand that's blowing at very high rates of speed.

DW: That makes sense.

CG: And the minerals underneath the planet-- I think I mentioned before, one side, because of impacts, caused crystallization of some of the rock.

DW: Right, you said shocked quartz was formed.

CG: And causing one side to be kind of an anode, cathode and anode on each side. So the surface, especially around the equator, will build up an electrical charge in the ground as well.

DW: Well, that makes sense. It's the same principle where you take certain metals and you put them under pressure and you electrify them, and you make them magnetic. So this was the whole side of the planet.

CG: Well, the problem when you are building a base and you have all this static electricity to where there's lightning storms going on in the sand storms-- it was that much of an electrical field being created-- well, it's destroying their electronics.

DW: So this is equivalent of a CME? It's like some kind of really powerful EMP pulse or something?

CG: Yes. And these occur often.

DW: So does that mean that the equator region is just no good?

CG: It's not a good place to set up a colony. I'm sure they've overcome a lot of shielding problems to create colonies there now. I know we can fly through those sand storms now and not have any electrical problems. But back in the day when the Germans were, I guess, landing on Plymouth Rock and forging new territory, they found out that this was not a place to be, especially with the technology they had at the time. They were losing all of their technology. So they found out that the closer to the polar regions, within 20 degrees, I think, of the north and south pole, were the best habitable regions.

And it also happened to be where a lot of other groups had been setting up bases. So they had to find an area where they could claim and set up a base, and everyone on Mars, just like people associate Mars with war, all of the beings there are very territorial, which I guess you could say is warlike. But it's part of their culture to be very territorial. It's like putting too many fish in a fish tank.

And they had to stake out their ground and defend it. And it took quite a bit of doing for them to do so. And they weren't able to be fully successful until much later into the later '50s when they were working with the US and the military-industrial complex and had all of the resources of the United States behind them. And then they really were able to start building out and becoming more of a force on Mars to push back some of these other groups, just like Americans did the Native Americans. They pushed back other groups and took over.

DW: Manifest Destiny. So during a typical Earth year, the Earth is tilted to the sun, and we're going to have seasons where it's going to get really cold or really hot depending on where you are, and that changes. If you're building near a polar region, and you're in Mars winter, how is that survivable for human life, given that Mars is farther away from the sun, would therefore be colder based on what we know from NASA studies of Mars?

CG: It's much easier to deal with the cold. When you have cold, you're going to have frozen water in the form of ice. It's a lot easier to deal with the cold than it is to deal with living in a desert to where you have electrical storms all the time, and plus the atmosphere is a little bit more hospitable in those regions, even if it's cold, I mean breathing-wise. Even though it's a very small oxygen content level, there's still more and in the north and southern poles.

DW: OK. So are you saying that these German bases were built in what we would consider an arctic-looking region?

CG: Not in the arctic. Usually within-- we would call it the 20th parallel.

DW: Were there any critters on Mars that they could hunt and eat for food? Is there any life there?

CG: Yeah, there is life there. I haven't heard or read too much about them hunting. I'm sure, as rough as things got for the original Mars colony people, I'm sure they did eat what they could find on the surface. I just don't recall reading anything about them having barbecues of Martian critters.

DW: What different types of critters did they find when they got there? Do you have to dig down, or are they on the surface? Do they fly?

CG: Most of them are burrowing-type animal life, even this weird little-- there's this little bat-bird-like thing. They dug holes. When we were building this one outpost, we were seeing these little holes. And around dusk, they would fly out, and each flap of the wing, you'd hear kind of a cheep, cheep, cheep, cheep, as they would fly out. What they ate, where they went, I don't know. And then they would return and go back into their hole.

DW: What did they look like? What was their color?

CG: They were dark, like black, and they looked real rough, leathery, and almost like they had almost armor on them.

DW: I would think for anything to have evolved to live on such an inhospitable planet, that it would all probably have this type of armoring and real ruggedness to it.

CG: It was just interesting to some of the scientists that something so small with wings could fly in such an atmosphere. They didn't think that the atmosphere was dense enough for them to--

DW: To provide lift right for the wings, yeah.

CG: Right.

DW: How small is small? What was the size?

CG: I mean, they were small. I mean, like small, like the size of some of the birds that you see flying around here.

DW: Right. How similar did it look to a bat on Earth?

CG: The texture looked like a bat, like the wings looked like skin. But the head and the beak looked more birdlike.

DW: Oh, it had a beak.

CG: Yeah.

DW: Well, we could probably go through the taxonomy of a whole bunch of different critters.

CG: And I didn't see a whole lot. Personally, I only saw a couple of things. I saw plant life and those kinds of things myself.

DW: You did mention that. We got the plants in.

CG: And I saw that was catalogued early by the Germans. They catalogued a lot of different life that popped up in the smart glass pads.

DW: Were there things that looked like little crabs or spiders?

CG: There were large spiders.

DW: How large?

CG: Very large, like half the size of a person.

DW: My insider Jacob described cooking and eating those. And he said, it tastes like crab. I don't know why you'd want to. Were there things like worms that dig through the soil or like millipede, centipede type life?

CG: Well, I saw reported a large, almost like silkworm-looking worms that were burrowing and would also come out and lay in the sun at times and then go back and burrow.

DW: Yeah, the main life that I heard about from two other insiders who claim to have been on Mars was these worms that were very large, that would actually eat metal. And they would attach themselves to the side of some of these bases, and they'd have to go out with these harpoon-type guns and shoot them. But they weren't very fast-moving, so it really didn't pose any threat to you. It was a very boring job, apparently.

CG: Yeah these looked almost like larva-type, big, bloated worm things that would burrow underground.

DW: Were there any indigenous life forms that had evolved on Mars and had actually always been there?

CG: There is one group that was very elusive that I never saw but read about that were human-like that stayed in caves and always wore robes and were very elusive and stayed away from everybody.

DW: Yeah, I heard about an indigenous population from some others as well. Do you know about their height or their appearance?

CG: This sounds too much like out of a movie, but supposedly looked very much like us but are very reddish. And they claim to be indigenous from Mars. Whether that's true or not, I don't know.

DW: There's no way to know, yeah.

CG: But there was very little in the glass pad about them. They were very elusive. And whenever the space program would come in and build a new colony that was too close to one of their civilizations, they would move their entire groups.

DW: Really?

CG: Yeah, they stayed completely away.

DW: They didn't take offensive action?

CG: No. From what I could tell, they were very non-Martian, very peaceful. They wanted to stay completely away from all other life forms.

DW: All right. So that is quite a fascinating body of information. We're going to be coming back next time with much more on Mars here on "[Cosmic Disclosure](#)" because you need to know. I'm your host, [David Wilcock](#), and I thank you for watching.

Cosmic Disclosure: Finding Life On Mars

Season 2, Episode 8

DW: All right. Welcome to "[Cosmic Disclosure](#)." I'm your host, [David Wilcock](#). And we're here because you need to know. We have **Corey Goode** here. And even as I'm asking him questions, I'm learning many new things. We've been describing the settlement of Mars by originally the Germans. But the Germans were not the first ones to go there. There's been many, many groups there. As we're going to talk about more in this episode, we're going to get into all the different types of life on Mars because that is a huge subject. So **Corey**, thanks for being back on the show.

CG: Sure.

DW: First of all, you had mentioned before in previous episodes something about vegetation on Mars. Could you just briefly give us an overview of what you saw? Did you walk around on the surface? Did you see any plant type of life?

CG: Personally what I saw were kind of colonies of shrubs that were in an area where we were building an outpost. And these were very hardy, short, and almost cactus-y-like shrubs that were purple and red-- the thick, I guess, stalks that went into the ground. And they had sharp, pointy leaves that were very sharp.

DW: What part was purple and what part was red?

CG: Well, the stalk was purple and red. And then the leaves were also purple and red. And there were thorns on the stalk of the plant and on the branches of the plants. They were not something you could stick your hand in. They were very prickly, I guess you would say.

DW: So in a previous episode, we are talking about a possibly indigenous Mars race. You said they look similar to us. What type of race on Earth would they look similar to? What type of human?

CG: The description was that they had a reddish tone. They wore robes. They were very skittish and kept to themselves. And the ones that had been captured or interrogated claimed to be indigenous, that they were always from Mars. That's where they originated.

But the people that had interrogated them were unclear whether this was true because they had been deceived in the past by beings on Earth that had told us that they were extraterrestrials when they had actually been ancient Earth civilization breakaway groups. And some of these groups, since they had

been space-faring groups, obviously could have gone to Mars and set up colonies. And these could have been remnants of some of them.

DW: Let's go back now to the Germans arriving there for a minute. And you said that you personally witnessed flying over ancient pyramids that were still on Mars today.

CG: Partially exposed pyramids.

DW: Did they take any interest in that kind of stuff when they got there? Did they want to land on it or explore it? I would think the interest would be insatiable to want to excavate it and find out what it is and all that stuff.

CG: The only interest that was shown was looking for technology, ancient technology. But again, you have to remember certain areas are very off-limits to people, especially back then. The races that were there are very territorial. So if they wanted to visit something, they had to stop, take some pictures, samples, and then scoot and get out. That was a part of the equation of them doing close research on a lot of areas of Mars as well. Because the area was considered territory of another group.

DW: Did you ever encounter any information specifically regarding the face on Mars, whether it was artificial, who built it, anything like that?

CG: No. During my time there, I was not aware of the face on Mars. So I'm not saying it doesn't exist. I just did not see it. I did not hear it talked about.

DW: So we were starting to get into last time that the Germans settled near the poles but more in sort of like a taiga rather than a tundra type of land. They're not in the arctic area. But they're in that sort of permafrost.

CG: More of a Goldilocks area between the very inhospitable equatorial region and the very harsh area of the polar regions.

DW: So what are the temperature extremes in those areas? What's the low and what's the high?

CG: Because of the atmospheric pressure-- and it also depended on the season of where you were. But the temperatures could change 40, 50 degrees in a matter of hours.

DW: Oh, wow.

CG: I don't remember exactly the temperatures that were on the surface of Mars. I just know that it's definitely warmer than what the statistics on the internet are. One of the things that I wanted to mention were now, current era, the space programs are very careful about cross contamination of germs, bacteria, that kind of thing going from one planetary sphere to another one. Back in the '30s and '40s and early '50s, not so much. And especially the Germans, they were bringing crates and crates of supplies and instruments and all the different things they needed to Mars. And they brought some very annoying pests. They brought along cockroaches, rats, and other spiders, other Earthly pests, that have become a problem on Mars and have contaminated. The rats have gotten a little bit bigger but survive just fine out on the surface. But the cockroaches have become huge, like bigger than your hand huge.

DW: Oh my gosh.

CG: People joke around that cockroaches could survive a nuclear war and surviving on the surface of Mars is not a problem for them.

DW: Are there indigenous insects that the rats could eat? I mean, what do you think their food supply was?

CG: I don't know. I'm sure there are probably insects there because I know there were very large spiders. I just didn't read or experience any myself. This insectoid group of beings, they use a biological kind of technology to where they create smaller bugs or insectoids to do certain tasks.

DW: Like clones or something?

CG: Yeah, but they'll create like smaller insect-like drones-- if they're doing battle or if they're in a warfare type situation, then they create. That's a part of their technology. It's kind of a biological technology.

DW: Right. So they can control what these drones do, like a remote control?

CG: Yes. And these are more of a hive mind kind of, a true hive mind. A lot of people think they know what a hive mind is when they really don't. But they have a hive mind and more of an insect, kind of colony type of structure.

DW: Did the Germans bring vehicles that use rubber tires and wheels to drive around?

CG: Definitely. Mm-hmm.

DW: Really? Like jeeps or tanks, or what were they driving?

CG: They had developed special vehicles that were pretty much like built on tank chassis that were pressurized and of course armored-- always armored with the Germans-- that they used for going on excursions.

DW: Would they try to go into caves and look for technology artifacts?

CG: I know that they were always going on expeditions, looking for technology, looking for different resources on the planet, constantly exploring, looking for different resources, especially. The only time caves ever came up were when they tried to explore routes into these lava tubes to do reconnaissance missions to try to get an idea of how they could someday take over these lava tubes.

DW: You said that raw materials were transported to Mars by the Germans using a primitive portal technology that was very hazardous to biological life. How big was this portal? Could they get those tank-type vehicles-- could they build them here and just portal them in?

CG: Yes. This is in the beginning when they were exploiting the natural portal system that exists in our solar system. And they didn't realize the calculations involved and the positions of certain planets, other bodies around. There are a lot of calculations involved.

They actually ended up having a hyper-dimensional mathematics handed over to them by another race that helped with these calculations. And I saw this math used quite often, and there were very few numbers in them. There were all kinds of weird symbols. But they were written out on boards just like math equations are.

DW: But just to answer the question, then, did they have the means to portal in something the size of a tank?

CG: Absolutely, yeah.

DW: Really?

CG: Multiple tanks.

DW: Really? So it was large enough to get multiple tanks in all at once?

CG: Yeah, they could get a battleship up there if they wanted.

DW: What does this portal look like? If we're going to see it on Earth where it starts, is it a ring like in the Stargate program? What are we looking at?

CG: These portals are bubbles.

DW: Like an energy bubble?

CG: They look like an energy bubble. And on the outside of it-- if you've ever looked at a hot highway, and you've got that--

DW: The mirage.

CG: The mirage effect coming up off the heat of the highway. You have that all around it. And it is not like a wall, like a flat thing you walk into. You can walk into it from two different directions, or 360 degree directions. People could walk into it from those directions, and then on the other side, they'll be coming out in 360 degrees, those directions.

DW: Wow. Would you have to cross in? Like if you're going to walk into the bubble, would you walk in on, let's say, the 6 o'clock part and then walk out on the 12 o'clock part? Like you've got to walk through the bubble and come out the other side? Or could you--

CG: Your point of view is totally skewed once you walk in. So once you walk in, you have no idea from your base of reference when you come out. You just walk into this basic bubble, you walk in, and then as you do, it's a strange sensation of-- I don't know how to describe it. It's a strange sensation. And you are going in, and then you're being pulled in at the same time. And then you collapse into it. And then you pop out on the other side.

DW: Is there a sense of duration as this takes place?

CG: No. Not like in Stargate where there's this-- vzzz-- you're going through this ring, this tube. There was none of that sensation.

DW: It's a very rapid compression and expansion?

CG: Right. And it does affect you. They give people shots and stuff to help them with the effects. But it's similar like if you put a very strong magnet close to your brain, how it gives you a real nauseated, confused feeling. You have that.

DW: Yeah, Henry Deacon actually said they gave him something he called [? lorentzil ?] as a supplement or drug that he took to try to ease off what he was calling transdimensional disorder. You called it temporal dementia, but very similar terms.

CG: And when they would transport a bunch of items, they would put the items in area where the bubble would appear. And then the bubble would pop up. And the bubble would be one size. And then you would see things almost like they're melting, going into the portal.

DW: Really?

CG: Uh-huh. And then they would pop out on the other side.

DW: How fast would that motion look?

CG: Very quick, depending on the density and the size of what was there.

DW: It's almost like something getting sucked into a bubble, like just-- which-- through a straw.

CG: Going down a drain.

DW: Wow.

CG: Yeah.

DW: Let's go into that room for a minute where the portal is. I'm assuming this is indoors. You're not going to do this in the open.

CG: No, a lot of times it's out in the open.

DW: Oh, really?

CG: These natural portals, sometimes they appear in the upper atmosphere. Sometimes they appear above the ground, underground. They jump all around the planet, along the grid system of the planet. Now, there are some of the ancient-- people have talked about United States going into the Middle East to secure some of this ancient technology, these portals.

DW: Like in Iraq.

CG: Mm-hmm. These are actual devices that have taken all of the guesswork out of using the natural portals. There is technology that uses point-to-point protocols to be able to send people and items safely. So that's a technology that exploits the natural portal system. There's a natural portal system that is occurring all around us right now. And they used to use intuitive empaths to help figure out where these portals were going to appear and for how long. But then they had artificial intelligence to help them with that.

DW: The Germans were using natural portals, and they would know where the portal was going to be and that it was going to go to Mars and then they'd line up all their tanks or whatever in that spot when it was going to appear?

CG: Right. And it wasn't always a lot of tanks. But they would utilize one area that they knew was consistent. And through this mathematics model that was handed to them and with help provided to them through extraterrestrial allies, they started using these natural portal systems in a very early and un-technical way before we started developing out what we use now.

DW: When we look at something like Stonehenge, is that a natural stone means of harnessing and exploiting these natural stargates? Does that help to attract them?

CG: That's exploiting and harnessing the natural energy grid of the planet but not necessarily having to do with portals-- not necessarily having to do with portals.

DW: Right. I'm curious about the Germans, though. Obviously there's some mystery in what you're telling us right now. Did they have some kind of antennas or technical devices that maybe they put in a ring or something that they can help to stabilize this bubble with? Is there any technology that they would build that was involved in making sure this thing works?

CG: Not in the very beginning.

DW: Really? Nothing in the beginning?

CG: In the very beginning, they were using the raw, natural portal systems. This is the very beginning. Then they started using the mathematics models to use electromagnetic fields and torsion to create point-to-point torsion fields between the two points. Torsion is a spinning field. On each side, they would create them at the same time, each side spinning in the opposite direction. But to stabilize and keep the--

DW: Oh, just to keep it running.

CG: To keep the point-to-point hole open longer. But our arrival there has thrown off the balance and even in closer to current era caused the insectoids and the reptilians that are there to have more problems with each other and problems with the new-arrival humans, Earth humans.

DW: You'd mentioned 40 main groups on the Super Federation Conference that have 22 genetic programs running on Earth and that they have a massive series of encampments on the backside of the moon. And they all have it regionalized into their own little domain. Do those 40 main groups also have regions on Mars that are their own territory?

CG: I've heard a few of them have a presence on Mars, but they mostly have presences on moons around gas giants and on other planetoids and moons. They're not so much on Mars.

DW: So Mars is sort of like its own little parochial district with its own gangs and in-fighting and members-only clubs?

CG: Right. As usual, as humans we decided to hop over there and plant a flag and started taking over territory. It threw off the equilibrium and the balance that was there.

DW: You said there were several false starts of where the Germans tried to build when they did it around the equator.

CG: Around the equator and a few other places where they built in the wrong place and ticked off the wrong groups and ended up being overrun and losing entire settlements. These were small at the time, the people in them.

DW: And when you say small, what are we talking? Like how many people would be working there?

CG: Dozens.

DW: OK. What is the first, that you know of, successful settlement that wasn't in a bad area and didn't get wiped out?

CG: These started to occur in the late '50s, when the United States really started getting-- or the military-industrial complex, the corporations that are this complex, fully got behind the Germans and involved with the Germans. This is when they really started having successes and also the might to enforce and protect territory.

DW: So we have obviously started to map out Mars, but I think there's a lot farther we could go in describing what has been done since these original settlements. Would you agree?

CG: Yes. I would say what we've done so far is we have set a foundation for what-- after the Germans and the US industrial complex pretty much formed a union and formed what we call the Interplanetary Corporate Conglomerate and moved out into the solar system and created a mass infrastructure and massively colonized Mars. We have basically set the foundation for that discussion.

DW: Cool. Well, that's what we're going to be doing next time. We're going to take our space program colonization of Mars and really get into detail on bringing it up to the present about how this enigmatic red planet has become a massive source of human habitation for this breakaway civilization. This is "[Cosmic Disclosure](#)." I hope you're enjoying it. I know I am. And we're here because you need to know. We'll see you next time. I'm [David Wilcock](#). I thank you for watching.

Cosmic Disclosure: Colonizing Mars

Season 2, Episode 9

DW: All right, welcome back to "[Cosmic Disclosure](#)." I'm your host, [David Wilcock](#), and in this episode, we're going to continue a fascinating discussion about the "alleged" colonization of Mars by our own military industrial complex, beginning with the Germans. I'm here interviewing **Corey Goode**. So **Corey**, welcome back to the show.

CG: Thank you.

DW: We've been talking about the Germans getting to Mars. And one of several interesting things we talked about in the previous episode was this harnessing of a bubble type of Stargate system. You said that in the very, very beginning of when they were using this technology that it was a strictly natural phenomenon. And you said the phenomenon could be in the atmosphere, could be on the surface of the Earth, or it could be inside the Earth. You mentioned that the Germans had extraterrestrial support on knowing where these things were going to appear. If this is a natural phenomenon, then why would

there not be more of a widespread knowledge about this? And why would other people have not figured out how to use these already?

CG: Other past civilizations have learned how to use them and have used them. Our current, highly boxed-in and controlled civilization are highly manipulated to believe certain things and disbelieve other things, what is and what is not possible. So if you are told by the mainstream media and government these things aren't possible, that's pounded in your head all the way through school and daily on the news and by society, the people around you, then that's your reality. It's not possible.

DW: We have very bizarre cases in tornado physics. Tornadoes sweep through an area, and there was a case of all kinds of weird stuff, like a cow being halfway embedded into the wall of a barn, or a woman who opens up the trunk of her car and finds a locked trunk carrying items from her bathroom like soap and shampoo, or roosters that are inside a jug. Do you think that the tornado is exhibiting some of these portal phenomena? Is a tornado some type of portal manifestation?

CG: It's all based on torsion physics. Well, torsion physics is a big part of it, yes.

DW: So the rotation of the air would be part of it, then?

CG: Yeah, it's torsion of the air molecules in space is being spun in a torsion field.

DW: So these portals are not just going to be in one location any time you want. There's a time factor in terms of when they appear.

CG: Yeah, that's with the natural ones.

DW: Right.

CG: After the Germans, after Paperclip, and we talked about Operation Highjump and then the German breakaway came in and signed treaties with Eisenhower and Truman and formed a sort of union with the military-industrial complex. And all of these corporations were infiltrated by high ranking German scientists and engineers. Well, all of these aerospace companies and other engineering companies started to build all of the secret space technology.

The military and the government itself could not do this. They did not have the ability to build all this. They didn't have the infrastructure. But the Germans highly coveted this infrastructure because they were already out there, and they needed this infrastructure to grow. They had big plans for what they had already-- they had a foothold out there, and they wanted to grow. They had large plans.

And these plans, when they brought information to some of these aerospace companies that they had been out to the asteroid belt and found entire asteroids that were made of precious metals that they had already been mining some, dollar signs popped in their eyes, in the eyes of these US capitalists. So they fully got behind this German grand plan to build out a giant infrastructure into outer space.

And these groups that formed their own secret space program later on after they helped the US government and other governments form the first space program, like Solar Warden, formed one that we've begun to call the Interplanetary Corporate Conglomerate. And it's a corporate conglomerate of these corporations from all over the world that build aerospace technologies. And since the 50s, they have been following the German footsteps from the moon and to Mars and building out the small infrastructure that they had with our great industrial might and have taken small, small bases and made them into huge bases, like on the moon. The Lunar Operation Command started off-- it was a small base with a little bit underground with small little swastika-looking base.

DW: When you say small, how many people could work there?

CG: I'm not exactly certain. I mean, they were always in like the several dozen at a time. These were small operations.

DW: That's pretty darn small.

CG: Yeah. But the ICC-- I will would refer to them now as the ICC, the Interplanetary Corporate Conglomerate-- really went in. They went in 100% behind the Germans' plan.

DW: Did they do this as soon as the ink dried on the contract with Eisenhower? Or was there some time involved?

CG: There was some time involved to develop the technologies that were going to be pushed out. But in the beginning, they were developing the technologies for the government for things that would become Solar Warden, the early precursor of Solar Warden. There were some earlier types of craft that were not as advanced. There's a whole history there.

DW: Did the Germans hand over all of what they had to the military industrial complex once this contract was signed? Or did they hold some things back?

CG: They held everything back. They handed three vessels over that were three different sizes. They called them the ARVs, Alien Reproduction Vehicles, when there was nothing alien about them. These were what we had talked about. They were basically current rebuilds of ancient Vimanas.

DW: Oh, wow.

CG: And they had the problem of the spinning vortex of mercury. When they added high electricity to them, the mercury would turn to gold, gold coral, coral-looking gold. They weren't shielded. They put off heavy EM fields that were very detrimental to the pilots. They had a lot of problems. And they gave that to the American military-- here, here, work out the kinks. Here's some toys for you. And then they were developing the nicer toys. The ICC always kept the most advanced toys.

DW: Now there's a leaked Truman memo that I had in "Wisdom Teachings" way back when, describing I believe in around the time of the beginning of World War II, where he was talking about interplanetary vehicles that they were hoping to exploit technologically. And this is years before Roswell. So how far was the US on its own with these back-engineering projects?

CG: Most of the technologies that they had recovered from crashed alien vessels were so far advanced that it was literally like a nuclear sub of our era being dropped during the Civil War era and telling them to reverse engineer it. This was a lot. This technology was a lot closer to their current understanding of physics and technology.

DW: So some of the stuff, like what we hear about from Colonel Philip Corso regarding the back-engineering of Teflon, Kevlar, Velcro.

CG: It's more of a material sciences.

DW: So they're getting that kind of stuff, computer chips, LED lights, integrated circuits. But they're not actually getting working craft out of it yet?

CG: They were able to repair, and there were some craft that were less advanced that they were getting somewhere.

DW: Oh, so they could fly the originals that had crashed. They repaired them and got them working.

CG: And they were reproducing some. They were crashing them a lot. I mean, they had their own program, and they were getting somewhere. But they were so far behind the Germans that it was embarrassing.

DW: Why would the Germans not want to share what they had with the military-industrial complex? Were they afraid of them? Were they scared that they were going to try to take them over?

CG: Well, I mean in 1947, the military had sent an entire fleet down to Antarctica to wipe them out. So you do the math. Their goal was to force the United States to sign these treaties so they could get their hands on the same industrial might that defeated the Axis in World War II. They wanted to exploit this industrial might and engineering might of the military-industrial complex and infiltrate it to co-opt it and use it to build out this infrastructure on the moon and Mars.

DW: So how many settlements did the Germans have on the moon and on Mars when this deal was actually implemented?

CG: At the time, they just had the one on the moon. Much later they built another one on the moon, along with their Draco allies.

DW: And this one on the moon was small, as you just said.

CG: It was small. And it was used just as a jump-- like skipping stones across a pond.

DW: Did they clear out like a large, kind of parking lot type area around the base where they could land things or have vehicles to park?

CG: That was all underground. So for Mars, they had finally mapped it out, done all the hard work, lost lives, found the areas that were best for setting up colonies, except they could only set up a couple colonies in a small area. There were other beings there that were preventing them from expanding their empire there. Well, once they had the ICC behind them, they were able to start arriving there after they started building up their-- just like before anyone goes to war, they start building more tanks, building more airplanes. They started building up their military might, secret space program wise.

DW: Could this be sort of like a surprise Trojan horse attack, where they build the stuff here on Earth, and then once they've already got like a whole battalion, then they just portal it in all at once, that kind of thing?

CG: Well, I guess you could say that. They built all of what they had strategically decided they needed to take over a certain area and build out a certain amount of colonies. And that was going to be their major, major foothold. And I believe "foothold" was a part of the project name.

DW: Really?

CG: I believe so. And once they began to arrive there, did battles, drove back the different groups that had claimed that territory as their own and they felt it was safe, they then started sending in the engineers. The engineers started to arrive. And then they started to build out areas for bases, much like the DUMBs, the Deep Underground Military Bases. Some of it was above ground, but most of it was underground or in existing caverns. A lot of them were around canyons and that kind of stuff.

DW: Did they ever have an experience like what you described on Earth where they're digging underground and they punch into something that was already there?

CG: Yeah. They experienced that, and then they would have to clear out nests of the beings that were there, very much like the United States, like I said before, arriving on Plymouth Rock and removing the indigenous people and planting flags and building settlements and colonies.

DW: Right. Here, have some blankets. They're nice and warm.

CG: Yes.

DW: They're smeared with smallpox.

CG: Yeah. And they programmed in their thinking. They remembered how the 13 original colonies had declared independence and broken away from the British way back when and formed America. It was very much made clear in the documentation that this was not going to happen. It stated, we are not going to have another 13 colonies situation on Mars. So they built out a lot of these colonies, and they were building out colonies for more people than they had at the time. And they were planning on bringing people from Earth. And this goes back to the brain drain that happened during-- what was it? '60s?

DW: '50s and '60s.

CG: '50s and '60s. And it just so happens that during the '50s is when they really started building these bases in earnest.

DW: In earlier episodes you said that a previous human civilization on Earth that was blonde-haired, blue-eyed predominantly, that we're calling the Agarthans, migrated inside the Earth. Were the Agarthans happy just to be inside the Earth? Were they involved in this program to industrialize Mars? Did they want more territory for themselves?

CG: They were not a part of this.

DW: Okay. Were there any extraterrestrial groups that were providing material and logistical support to this expansion of territory on Mars?

CG: The Draco alliance was a part of a lot of this.

DW: So their own weaponry and technical capability was part of how they were breaking up this-- you just called these nests, like indigenous beings?

CG: Actually, that almost entirely was done by us. But they helped us technologically. But as usual, we were sent in to do the dirty work. And we did and had no qualms about it.

DW: What kind of scope of atrocities were committed in this? Were there times where hundreds of thousands of intelligent beings were killed in a short period?

CG: Yeah, yeah. Hiroshima, Nagasaki type situations happened countless times.

DW: Are you saying they used nuclear weapons?

CG: Absolutely.

DW: Really? They nuked people? Doesn't that make it radioactive afterward?

CG: There is a-- I don't know if you've heard of this weapon that came soon after nuclear weapons. It's a nuclear-based weapon that causes a huge explosion and then vvv-vacuum.

DW: Yeah, that's a fifth generation nuke, right? That's what I've heard it called.

CG: Okay.

DW: There's a picosecond explosion that's a sphere. It's a perfect sphere. It's almost like a cutout. And nothing is left inside once it goes off, and there's no radioactivity. You can just hose it down. It's gone.

CG: Well, there is radioactivity, but it is all brought into a small area into the center.

DW: Yeah, I've heard that called Fifth Gen.

CG: OK. I haven't heard that. But they were using these types of weapons to not only create underground caverns but also clear out areas that were filled with sentient beings.

DW: That is nasty.

CG: That's the way those guys roll.

DW: That's the government.

CG: And when they stated that they were not going to have a 13 colonies situation again, they were going to make these colonies the most draconian, and they were going to be very tyrannical type setups to where there was absolutely zero, zero, zero chance that anyone was going to be able to form any type of rebellion and declare independence and there be an independent Mars.

DW: When they're saying they don't want a 13 colonies again, is this getting back to the idea that even though we're talking the Germans, that the deeper group in these German secret societies that was behind all this is the same sort of Cabal, Illuminati power structure that's the British monarchic empire?

CG: This is coming from the perspective of the current-era ICC. These are the big fat-cat bankers and corporate people of the aerospace companies. That's coming from these guys.

DW: Right. So not the Germans now. This is the merger with the Germans and the ICC.

CG: The Germans were very much a part of it. At this point now, you can't separate the two. They're now one entity. And they then began to approach many thousands of very highly educated people and present them with information saying, listen, the Earth is about to undergo some very traumatic changes. You, your family-- they would especially approach people like you if you were a physicist and a geologist and had all these degrees, your wife happened to be a nurse or a doctor-- bonus-- and if you had three kids that they had secretly gotten genetic tests from. They did all this background stuff before they approached people.

And they would make them an offer. They would show them pictures of underground bases here on Earth that the elite are going to that are super advanced and say, this is where you would go. You'll be living like the Jetsons. This is back like in the '50s when people were promised, hey, before too long,

you're going to have a flying car and all this.

So the people were like, OK, cool. And they said, we're going to take you to Mars. You will live there and be saving the human race by you being special, having special genetics, and you will help save the human race and at some point come back to the Earth-- there were several different stories going around. And these people would pack up their little-- they were only allowed to bring just a little bit, not much, what they could carry. And these people weren't allowed to tell their families anything. And all of a sudden, these people just disappeared.

DW: Well, and I've heard from other brain drain people-- whistleblowers-- that if you live in a foreign country, you just tell whoever you know, I'm going to this other country, I'm leaving the country, and I got this great job opportunity. And then they'll have you write out postcards.

CG: A whole bunch of postcards, rubber-band them, hand them-- yeah.

DW: Yeah. And then you send them out over time and just gradually taper it off.

CG: Yeah. That's someone else's job to do while you were gone. But these people were then taken to Mars, and they would arrive, and reality would hit them. All of a sudden, all these guys would arrive with weapons and say, follow us, march them to like an 8 by 10 kind of room and say, this is where you're going to be staying. Here's your job roster. This is what you'll be doing.

Your children, when they get to be 12, 14, will be put in arranged marriages according to their genetic matches. We will take care of-- depending on how they test and genetically what they seem to be best at, we will educate them to do that to contribute to the colony. Welcome to Mars. And then that was their new life, a life of tyranny, a life of slavery.

DW: Were there Hemingway novels and historical books and things that were brought from Earth to these colonies so people had something to read, something to occupy themselves with in their free time?

CG: I would imagine that there were. I'm really not too sure.

DW: Well, one of the things that we saw with the negative commenters when you talked about this online was thinking that these people are going to lose all connection to their Earth heritage once they go. But I would think that the oral history alone would be preserved, if not some form of documentation.

CG: Well, as a part of these children's education, of course they're going to get some sort of-- you know, the victors write history. They're going to get some sort of skewed Earth history taught to them. So they're going to learn about the World War I and World War II from the point of view of the ICC, about all the different countries in Europe, about the different states in the United States, about South America. Because all of these people are a hodgepodge of people from all of these places. These people are like generations removed. My great-great-great grandfather-- or however many greats by now-- grandfather was from Abilene, Texas, or from Chicago or from Bangalore or India or from wherever. So to think that these people are going to have no idea of the geography and history of Earth is ridiculous.

DW: Now, I asked you this about the LOC before, but I want to do it again now. If you go into one of these facilities, if you filmed it from the inside and these people show up there and they become slaves, is there anything remarkable about it that we would be able to think was different than if it had been in a building on Earth?

CG: You're talking about the LOC?

DW: No, I'm talking about the Mars facilities.

CG: No. The Mars facilities, yes.

DW: Really?

CG: Now, the Mars facilities, they-- you might think that you're in some sort of Naval facility or something. The living quarter areas are all labeled in alphanumeric. It looks very, very much like a military installation. There was one place that we went that they had to fix a damaged piece of equipment that was essential, that the ICC couldn't get their personnel to in a manageable amount of time. And we were escorted to, told not to make eye contact with anybody, not to talk to anybody, that whole thing.

And there was a wall where people were like hanging art. I mean, it looked like they were doing some things for the mental health of people to make them not totally depressed and suicidal. But the people looked gaunt, pale, and just almost like drones just going about their day.

DW: Well, a life of total enslavement would do that. We're completely out of time for this episode. But this discussion is blowing my mind. Always learning more when we talk.

So when we come back next time, we're going to be getting more into all of these interesting subjects,

continuing the narrative forward, fleshing out for you the space program and what's really going on behind the curtain. This is "[Cosmic Disclosure](#)." I'm your host, [David Wilcock](#). And thank you for watching.

[Cosmic Disclosure: Conquering the Solar System](#)

Season 2, Episode 10

DW: Welcome to "[Cosmic Disclosure](#)." I'm your host, [David Wilcock](#). And we are exploring the fascinating testimony of an insider named **Corey Goode**. Thank you for being on our show.

CG: Thank you.

DW: So when we last left off, we were talking about the ICC, or Interplanetary Corporate Conglomerate, as they're called, using the industrial power of the military and corporate might of the United States post World War II to create a massive expansion. Now, you said that there was a seed base on the moon that was small, that was built by the Germans, that was then expanded quite considerably by the ICC. And you also said that there were many failed attempts at bases on Mars, and then certain bases actually stuck and were able to stick around. And then those also got built out.

CG: Correct.

DW: OK, so how many of the seed bases lasted on Mars? And where were they?

CG: The first couple of German seed colonies that actually made it on Mars were within the first 20 degrees of the polar regions. There was one in particular that the ICC used to expand and build off of. And this one was somewhat in a canyon area, into the side of a canyon, and advanced in and was under the surface of Mars, not on the surface.

DW: And you said that how they hollowed out more space inside the Earth was with these, what I was told were called Fifth Gen type nukes, where they just create a big, sudden explosion with no lingering radioactivity?

CG: Yes.

DW: The one that became the mainstay, was it in the northern or southern hemisphere?

CG: The northern hemisphere was where the first main base that was a German name, in the beginning which was built, was built out.

DW: OK.

CG: And it was built out in a huge way. It was built out to contain a large amount of engineers and scientists. And also, a little ways away an industrial complex was built where they were going to start producing I guess the items that they needed, technology that they needed, that came from raw materials they mined on Mars, moons, and in the asteroid belt. They took these raw materials, turned them into usable materials, and even composites, and created what they needed in these rather small plants in the beginning.

DW: So what was considered to be the desired technology that they were building out there in the beginning? What was their initial attempt? What did they want to make?

CG: They were building what was needed to expand on Mars.

DW: OK.

CG: So in the beginning, they were just building what was needed to expand their infrastructure on Mars.

DW: So are they building materials on Mars out of local stuff, like you said before, involving the Kevlar bags and then making concrete out of local earth from the Mars sphere? What was the building technique? You said that these industrial facilities they had were building the things they needed.

CG: Yes, they were building-- the raw materials were coming from mining that was going on, on Mars, on various moons, and the asteroid belt. These raw materials were taken to the Mars' industrial areas further away from the colonies and converted into usable materials, whether they be melted down into certain metals that were put into dyes or forms or converted into composite materials.

DW: Well, you're touching on an interesting thing now because you're describing mining that's not just happening on the moon or Mars. So we haven't really gotten into yet the scope of-- I would guess there would have to be some kind of facilities built to mine on these moons or asteroids or wherever.

CG: Some of these asteroids are incredibly huge to where there are three- to four-man teams that live there on these asteroids and operate--

DW: Three or four people?

CG: Three or four people. And they operate these mining facilities. A lot of it's done robotically and remotely through remote machines. The raw materials are then put into these large freighter craft and then flown back to the planet Mars to the facility that it needs to go to. And then the raw materials are taken out of these freighter craft and then converted into the materials that are needed.

DW: You said in a previous episode that the Germans had discovered, through extraterrestrial assistance, these spherical, natural portals they could use to teleport even something as big as a battleship to Mars or elsewhere. Are there such natural portals available to them on these asteroids or on the moons? Or why would they have to use a shuttle craft, is really what I'm saying.

CG: It's just more practical for them to transport these materials in these large freighter craft to and from the asteroid belt and the moons to these locations.

DW: If we saw one of these freighter craft, what would it look like?

CG: It's almost like a super large shipping container with small little wings on each side that just barely jet out. The wings don't look like they're large enough to use the Bernoulli principle to give them flight in an atmosphere, but there's wings on them nevertheless, real small. And the front has about a 45-degree angle where the cockpit is. And the back part is basically like a big-rig or a shipping container. That part is detachable. But I've never seen it detached. I've only seen them attached and coming and going.

DW: You said that the original German craft were using this mercury propulsion system, rotating mercury. What is the power source for a craft like these shipping containers? Are they still using the mercury at this point? Or have they gotten in a more advanced propulsion system?

CG: They're using more advanced propulsion systems, and there's different types of propulsion systems. There are the torsion systems, which a lot of people call warp drives.

DW: People in the program actually say it's a warp drive? Or you're just saying lay persons?

CG: We would consider it warp drive. It creates a torsion field. You have like the engine here, and on either side, you have a torsion coming from the center of the device on out.

DW: The field?

CG: The field, the torsion field. And then they control how much energy is going into the torsion, the field on either side. And it causes the space time to twist, causing it to be pulled in one direction or pulled in another direction because of basically like the warp drive that they've depicted on Star Trek. And there are--

DW: So it's almost like it's creating a hill in space time that it's falling into as it goes forward.

CG: Right. And there are temporal jump drives that are extremely advanced. They had to place buffers on these temporal drives so people weren't jumping back and forth in space time in our local area.

DW: Meaning time travel.

CG: Right. And it works almost like teleportation. It's instantaneous.

DW: So what was your understanding of time as it was presented to you? Did they explain the discrepancies between the physics of time, like Einstein saying it's one-dimensional, and it only moves forward?

CG: Yeah. Basically they showed one of Einstein's equations-- he had things close. He just needed to flip one equation over here. His later things that were suppressed, he had even closer. But the physics that are being pushed on us are archaic. If we compare it to medical terms, it's like if you have a fever, let's cut you and let you do bloodletting. It's that far backwards in the way of thinking.

DW: All right, let's stick with the drives for a minute. So you have the space time, like the squeezing the pumpkin seed out your fingers kind of thing, where it's falling into the hole that it creates.

CG: Yeah, the torsion.

DW: Torsion drive. Then you have this temporal drive, where you could actually travel in time, but you say they put buffers on it. And why did they need the buffers?

CG: Well, to prevent people from doing it on purpose, and also there are accidents. They actually had developed a communication device, and it was actually based on something that you mentioned earlier, quantum entanglement.

DW: Right.

CG: And each of these devices, they would take an isotope that they were quantum entangled.

DW: Right.

CG: And these devices, you would speak in one, and they also had video. And there was no signal being sent between them. They were completely secure and unhackable.

DW: Right.

CG: And they called them quantum correlating communication devices. And these were in vessels. And if a person had a bad jump and ended up somewhere or some time they shouldn't be, the two isotopes would be out of harmony, I think they called it, for a certain amount of nanoseconds. And they were able to calculate when and where the person or the other device was by calculating how long it took the vibrations to come back into harmony.

DW: So could you talk to somebody in a different time by quantum entanglement?

CG: Mm-hmm.

DW: Really? Wow.

CG: Anything that's quantum entangled, no matter how far you separate them in dimension, reality, time, space, they stay entangled.

DW: And by like the Doppler effect, the lag time, you can calculate space and time coordinates of where that person ended up falling into?

CG: Exactly.

DW: Did you experience time paradoxes, like that kind of thing? Is that part of why they don't want people jumping back? Can they mess with our timeline somehow?

CG: There were a lot of experiments of people going back in time and doing experiments. And they were saying, oh, we've created all these divergent timelines. And then they were sending teams going back trying to fix them and making things worse and worse and worse. And finally, they realized that time is like space. It's elastic. And all these paradoxes all collapse and go back into a singularity. And that our consciousness controls these timelines, has an effect on these timelines as well and which timeline we're going to be-- we choose which timeline we're going to be in consciously.

DW: Let's just get back to what we're trying to cover in this episode for now, which is some of the people are traveling in temporal drives, and there's build-outs of colonies in our solar system. So if we look at the history, you've got the moon first, then Mars. How soon after they got to Mars and they got successful, stable encampments, did they start building facilities on asteroids or other moons?

CG: Almost immediately.

DW: Really?

CG: Yeah, the Germans had already started mining certain asteroids. And this is one of the reasons the ICC wanted to go out there. They heard there were asteroids out there that had platinum and gold. And the talk down here on Earth about there being a discrepancy in gold, gold being rare, silver being rare, that is a total manipulation. I mean, just on Earth the syndicates have hidden a bunch of gold.

DW: Right.

CG: There's tons of gold. And the gold that they're finding in these asteroid belts, atomically you look at Earth gold and this gold, they're the same. They don't have different atomic structures. It's gold. So there is plenty of gold in the solar system and so many tons of gold and platinum and silver and other elements in the asteroid belt.

DW: Could you actually find entire asteroids that are just like a piece of gold or a piece of silver?

CG: Well, I wouldn't say that they're entirely a big nugget of gold but are very much gold. It doesn't take a whole lot of refining to separate the gold from the bedrock, or what used to be bedrock, that it's in.

DW: Well, I would think if they wanted to wrangle an asteroid like that, you'd need a pretty big craft. So what were the original sizes of craft that the Germans were using as they made this expansion outward?

CG: Small. They were flying to these large-- I mean, picture this huge asteroid and these little bitty craft. They're landing on these asteroids, and then they're setting up mining facilities and slowly digging further and further and further and further in to these asteroids to where they're getting more and more hollowed out. Well, these asteroids are constantly being hit by smaller asteroids and this kind of thing.

Well, you have safer working conditions inside. So most of what's going on is further inside the

asteroid. And once they had gathered a certain amount of raw material, whether it be gold or platinum or any of these other things, it would be put into these large container craft and then flown to its destination to be changed into usable materials.

DW: When I was talking to **Pete** Peterson, he described the really interesting properties of a metal called bismuth. And he said that you could extract it into a very, very long wire and then make a coil with bismuth and run electrical current through it, and you get all kinds of weird stuff start to happen.

CG: Yeah, I believe that that is what is used in the Gauss guns.

DW: What's Gauss-- Gausskin?

CG: Guns, the weapons that are basically like rail guns.

DW: Oh.

CG: When they took them apart to show me, they had rods running down the barrel and then this thin wire-- they called it the coil-- that ran along the outside that basically worked like a rail gun. An electromagnetic field pulsed. And also an electromagnetic field pulsed down the rod and sent a projectile out at like-- I can't remember. It seemed like 5,000 miles an hour or something. It was like an incredible speed. And the projectiles were just under like 50 cal.

DW: Wow.

CG: And at the bottom they had basically a grenade launcher. And these grenades were like 20-gauge shotgun shells, just in size and shape-- they didn't look like shotgun shells-- that were launched in a similar manner that had a very advanced plastique type explosive in them that gave a much larger report or explosion than like an M203 grenade launcher. And these were the rifles that the security details would carry.

DW: Did the ICC or the Germans develop advanced computer technology faster than we did on Earth that they could start to use in all this robotic mining and things?

CG: Yes. They've had computers, computer systems, and quantum computers much, much longer than-- way before Bill Gates and IBM started to put out motherboards and integrated chips.

DW: So can you just spell out for us now-- when the Germans first got started, what was the approximate year that they first got a stable encampment on the moon? Do you know exactly?

CG: I know that it was in the late '30s that they were using an older facility that they had pressurized and were using while they were building another smaller base.

DW: This was like Ancient Builder race type of ruin that they found?

CG: Right

DW: OK.

CG: And then that was in the early '40s, I think, that they completed this small base of theirs.

DW: When was the first stable base that lasted on Mars?

CG: I think around '52 to '54 is when they really started getting the United States to sign the agreements, and they had only just really got a good foothold on Mars by then. They really had a lot of setbacks on Mars. They lost a lot of lives.

DW: So almost like an 18-year struggle.

CG: Yeah. I mean, they really did the pioneering work on Mars.

DW: But they had better success building mining facilities on asteroids and moons prior to stabilizing Mars?

CG: This was at the same time.

DW: Oh.

CG: Yeah. Once they had a stable area to call their own territory, then they were then starting their mining operations. And their mining operations were more-- I guess when a geologist goes around a large region and is picking up certain rocks, doing core samples, getting a good idea and then labeling certain areas and grids. I think it was more of an excavation and figuring out what was out there. And when they found certain things they needed, they would start small mining operations.

DW: Did anybody from Earth that we would know of get like the dog-and-pony show maybe to help keep them quiet, like a president or prime minister, early in this game? Did they get to see what was going on so they knew what they were involved in?

CG: I believe Eisenhower may have. He was the one that ended up, ironically-- him being a general in World War II, I imagine it was very difficult for him to come to terms signing treaties with these German breakaway groups.

DW: Oh, yeah.

CG: I can imagine it was really hard for him. But I think he ended up after-- in 1952, things really got heated because we were turning down the offers, the demands. The Germans were making a lot of demands about wanting access to the United States and our resources as a part of a treaty. And we were denying it. We told them no. We were trying to play hardball negotiations.

And through the Paper Clip, this German secret breakaway group knew that the highest law in the land was that the United States didn't want any of its people to know about the existence of extraterrestrials or higher technology, so they used that against us to force us to sign a treaty with them. And in that process, I'm sure that Eisenhower more than likely, along with all of these corporate people that saw dollar signs, got the dog-and-pony show, and then the corporate people were just 100% on board and wanted to exploit everything that the Germans had found.

DW: Sure, that makes sense. I don't really have a strong sense-- you've just kind of said "moons and asteroids." So what moons are we talking about? How many of the moons in our solar system-- because there's a lot of moons in our solar system.

CG: Yes.

DW: There's at least 100.

CG: Right. There's a lot more 100.

DW: OK. So how far did this go? And how much did it expand over time? What were the earliest moons that were conquered or landed on?

CG: All of this is very tricky diplomatically because a lot of moons are off limits to everybody because they're diplomatic territory, "owned" by some of these 40 or 60 groups.

DW: The Super Federation.

CG: Super Federation people, especially around Saturn.

DW: Really? Saturn has a lot of moons.

CG: Yeah, yeah. But there was a lot of activity around the moons of Jupiter.

DW: Germans and ICC people?

CG: Mm-hmm. And Uranus. And then the asteroid belt. But I don't know or remember any actual moon names or what actual element or resource they were exploiting from which planetary body.

DW: Well, Io is one of these weird ones that has all these volcanoes and stuff like that around Jupiter. And it's very close, and it's quite hot. Is a moon like that too inhospitable for them to land on?

CG: Yeah, there's some that they could not get access to. I remember reading-- there was one moon that was circling around a gas giant that was spewing some cloud of some element out that they were collecting, they were collecting from space from behind the moon. I know that sounds ridiculous.

DW: No, not at all, actually.

CG: I haven't seen anything that says a moon around a gas giant is spewing stuff into space, but--

DW: Well, I actually have. Io, as we were just talking about, does have very active volcanoes that are spewing off a whole bunch of particles--

CG: Into space?

DW: --that have created a ring that actually looks like a saucer falling, when the saucer falls and it's kind of doing this as it's coming to a rest. That ring tips with the gravitational field of Jupiter. And there's been a significant increase in the particle density of that ring since the 1970s that NASA has tracked.

CG: Have they done a spectral analysis of what the chemical is coming out?

DW: Yeah, and it's got lots of weird stuff in it like argon and neon and helium and oxygen and a lot of things that we might be able to use.

CG: OK.

DW: So that does make sense to me.

CG: OK.

DW: Every time I ask you questions, I'm learning all kinds of new stuff. So this is really mind-blowing. This is "[Cosmic Disclosure](#)" because you need to know. I'm [David Wilcock](#), and we'll see you next time.

[Cosmic Disclosure: Beyond the Limits of the Sun](#)

Season 2, Episode 11

DW:: Welcome to "[Cosmic Disclosure](#)." I'm your host, [David Wilcock](#). And we are interviewing **Corey Goode**.

So we've been talking about the development of our solar system by the military industrial complex, and the faction that we have been focusing on is the defense contractors that merged with the Germans who originally did the work that has come to be called the Interplanetary Corporate Conglomerate, or ICC.

So here with more on the ICC is **Corey Goode**. **Corey**, thank you for being here.

CG: Thank you.

DW: We were talking in the previous episode about certain regions that as the ICC expanded out into our solar system, they were mining various moons. You had said that one of the areas of particular interest that they were working on was the moons around Jupiter, and you said the moons around Uranus. You also said that Saturn was essentially the forbidden region in some sense.

Now, previously I talked to you about the people that had settled on the moon on the dark side. And you said those are the super federation types, but that Mars is kind of like its own territory.

CG: The moon is a hodgepodge of the Super Federation types and the Draco Alliance types-- a whole bunch of different types, many of whom do not like each other. But this is a very strict diplomatic zone that people are just a few kilometers away from each other who live in strict peace that have been at war for millennia, to make that clear.

DW: Sure. And you said that many of the people that live on the moon don't live on Mars.

CG: Correct.

DW: And that Mars had its own sort of separate domain. Is there a relationship between the settlers on the moon, the settlers on Mars, and the settlers in the Saturn moons that you were describing? Or are they all different?

CG: There's quite a bit of difference. What I've described as this Federation Super Council, this is a Super Federation made up of other federations, councils, and other different organizations and groups.

DW: So hence the word "Super."

CG: "Confederations" I've heard used. And it's kind of like a giant UN of all of these different federations, confederations, councils, that come to meet. And there are 40 main groups with 20 other groups that are there a fair amount of the time but not all the time.

Now, these groups are more of the human-looking, human type. And their bases seem to be mainly on the back of the moon and on moons of some of the gas giants, especially Saturn, so much so that there are areas around certain moons of Jupiter and Saturn that our vessels were completely forbidden from going anywhere near. And this is in our own solar system. These areas were off limits.

DW: Our vessels meaning your solar warden faction?

CG: The Secret Space Program, all of Earth's Secret Space Programs were not allowed. No Earth space vessels were allowed within a certain distance of these moons.

DW: Now, I had Jacob, my space program insider who I've mentioned before, tell me that some of these moons, the entire interior would be like a geodesic shape, that has, like a dodecahedron let's say, pentagonal faces with trees and habitable land, and the whole interior of it is hollow. And you can fly your craft along, and you get to a certain point and then you make a turn and you fly this way, and when you get inside there it's almost like a paradise type of world. Do you think that might be some of what is going on in these Saturn moons, that they're that built out inside?

CG: Mm-hmm.

DW: Did you encounter information like that yourself?

CG: Yes.

DW: Really?

CG: And I encountered information that I've tried to stay a lot away from. All of this is so incredible, but our moon is also an artificial body.

DW: That's something that almost everyone in the know that I've spoken to has said.

CG: It's in a locked orbit with the Earth with almost like a tractor beam technology that has locked it in orbit with the Earth, and they found the energy field that goes deep within the Earth to where it's focused to anchor the moon. And the moon only changes position, as in it goes further from the Earth by, I think, centimeters every certain amount of years or something.

DW: You're saying that's not normal for a moon?

CG: Absolutely not. The Earth's density and the gravitational effect it has in time-space, creating a torsion field by its spinning and contorting space-time, is not enough to capture something of what scientists say the density of the moon is. And because of the spinning of the Earth, it should have an effect on the moon to cause it to spin.

DW: Oh, wow.

CG: But the moon is locked in. It doesn't spin. It's locked in too close to the Earth, and it is not something that could have been captured. None of the scientific models have worked, that it was once part of the Earth and was flung out. It was around 500,000 years ago that the moon became a satellite.

DW: Which is exactly what all the other insiders have told me as well.

CG: Well, that's the documentation.

DW: And you're familiar with-- I said this to you on the phone, which blew me away. I mentioned Brilliant Pebbles.

CG: Yes. Operation Brilliant Pebbles, with a backwards traced-- And they use the same program in forensics on Earth all the time. But in the asteroid belt they were able to, after they mapped all of the asteroids and their trajectories, they were able to reverse, over many hundreds of thousands of years, where they all would have been at one point.

DW: We've just had in the very recent past now photographs sent to earth for the first time of Pluto. Pluto's pretty far out there. And then you've got the Oort Cloud. Is there anything like the Oort Cloud, where they've gone that far out to the edge and developed mining facilities or colonies there, as well?

CG: There are a lot of surprises out in the Oort Cloud.

DW: Really?

CG: And Pluto's a very interesting planet to lead in itself. It's a very strange orbit. It's not on the orbital plane that all the other planets are on.

DW: Yeah. Pluto's on an elliptical orbit like this, and everything else is like this. That's true.

CG: And that has something to do-- we're a failed binary system. There are other Pluto-sized planets inside the Oort Cloud.

DW: Which they just haven't told us about?

CG: Right.

DW: Wow. Is there more Ancient Builder Race stuff out there that they were able to find and pressurize and use for their own colonies?

CG: They found the Ancient Builder Race stuff everywhere. In the Oort Cloud-- I mean, it's everywhere. The ICC has gone out into the Oort Cloud, and they're establishing bases on planetoids out there as well.

DW: Up until now, everything we've talked about is inside the solar system. Did they have trouble getting out of our solar system, the ICC? Is it easy to leave the solar system? Did they go anywhere else? Did they find anything else?

CG: Yes, they're traveling to several solar systems.

DW: Really?

CG: Well, there are two that are working quite a bit outside of the solar system. One of them is that NATO-type group, the League of Nations Secret Space Program kind of.

DW: Global Galactic League of Nations, we call them.

CG: Global Galactic League of Nations. And they've been working almost exclusively outside the solar system, and the Dark Fleet that is a super advanced, warlike, offensive secretive space fleet that work alongside the Draco alliance and fly outside the solar system and help them in their warfare.

DW: OK. So we got those two things, but you mentioned several systems. I'm curious if the ICC is colonizing outside our solar system, besides the Global Galactic League of Nations. Were there materials that they found outside our solar system that they needed that they didn't have enough of here? Anything like that?

CG: All the raw materials here are what they need, but there are plenty of other bases in our local star cluster that are from several of the different space programs, including the ICC.

DW: You said plenty.

CG: Yes. And from what I've seen, the one that I described being brought to was on a moon around a gas giant.

DW: You're talking about the GGLN, the Global Galactic League of Nation base? That was a moon?

CG: That was a moon.

DW: Oh. But I thought you said there was water there.

CG: Yeah.

DW: There was water on the moon?

CG: Yes, yes. It was inside a cave where the train stopped that went through the portal, and then to the left, where the secure area-- to where people went in deeper into the facility, and to the right, you were like in a grotto cave area. And there was a large cave entrance, and as you looked out you could see other moon-type structure things out in space. And then there was a pool of water outside, a luminescent pool of water that people were having, like R&R in.

DW: Well, NASA has recently stated-- and this is on public record-- 20% of all stars we see have Earth-like planets based on their calculations. So that's just the official word too, which might even be an underestimation. Is that consistent with what the ICC and these other groups started to find when they went to other stars? Are there an abundance of watery planets that may be able to be something we could move to if we needed to?

CG: Yes, but most likely it would be a scenario to where we would have to go and take it from somebody.

DW: Right. Most of these planets are inhabited already.

CG: That kind of seems to be the model. Any of these moons-- a lot of these are moons.

DW: Really? Earth-like moons?

CG: Earth-like moons.

DW: Do they orbit gas giant planets?

CG: Mm-hmm.

DW: Really?

CG: And a lot of these are super Earths, like Earths. We're not that rare and special as we think we are. I mean, yes, we have a wide range of genetic diversity and life here. But from the traveling that the Secret Space Program has done, the trade we've done with other ET groups that have brought us specimens of life from all these other planets, there's an unbelievable amount of life out there. And this is not going to happen because things are going to change-- but if we did go down a road to where we used up all the resources on our planet, and we're going to go out and find another planet to live on, it's going to be very difficult because the model of the galaxy seems to be any planet that is like this is going to have tons of life and also intelligent life.

DW: Both on the surface and inside the planet for the most part?

CG: Definitely on the surface.

DW: So what are the logistics of getting to another solar system? You mentioned that the Germans started out flying over the course of a few hours to get to some of these places, but that as the technology's improved, it's only a few minutes.

CG: Going from star system to star system now, it is routine. And it takes almost no time.

DW: Even for a larger jump?

CG: Even for a larger jump. You are traveling through-- Every planet, every star, every galaxy has an electromagnetic relationship with every other one. And there's kind of a web between each one.

DW: So there's some kind of electromagnetic filaments?

CG: Filaments. And if you calculate it right, you can travel from point A to point B whichever, wherever you want in one jump. And instead of traveling through open space with a superluminal engine or craft, you can travel through this portal filament where time does not exist. And it's pretty much instantaneous.

DW: Is that something that you have to wait for the filament to be in the proper alignment?

CG: Yes.

DW: OK.

CG: It's very much something that has to be calculated, or you don't end up where you want to go.

DW: Are there are other ways to do it that involve kind of skipping around? If certain filaments are not available, you can take plenty of other ways to get there.

CG: Yeah. It's just like if you want to fly from the East coast to the West coast, you can take a one-way flight, or you can take a flight that has a few layovers.

DW: Are there routes in which they could computer program the whole thing, and no human pilot calculation is required? And if they drop off in one star system, they just immediately zip over to the next portal and take off again? Or are there times where they have to kind of hang out and wait for one to open?

CG: Yeah. That's what happens with the portal system that's close by our star system, and why we have so much interstellar traffic from other beings. Most of them fly by and don't even stop by our solar system. They fly close by our solar system. They stop, wait, do their calculation, wait for-- according to their calculations, the correct timing, jump on that one web that leads to their destination, and then they're off.

DW: So none of it takes that long?

CG: No. To these ET societies that have been doing this for so long, they've got it down pat.

DW: It's probably all automated too, right?

CG: Most likely.

DW: Not all planets are going to have full habitation. There's probably going to be prehistoric planets that don't have intelligent life having evolved yet.

CG: Yeah, they're all different levels of development, the planets.

DW: Did the ICC or any of these space program groups find any prehistoric planets near us?

CG: I don't know where they're located, but I've read about yes, there are planets that are very much described as being very prehistoric-like conditions.

DW: Hmm. Have they ever attempted to utilize those planets or land on them or create an outpost around them or anything like that?

CG: There's one planet that I think some information has leaked out about that is somewhat of a prehistoric planet that they had found a portal connection to, that Earth syndicate groups that were also ICC-related groups were sending people to. It's more kind of a continuity-of-species type project to ensure the survival of the species.

DW: How prehistoric is this planet? Is it down at the level of like the trilobites and the crawly crabs?

CG: We're talking like dinosaur kind of stuff.

DW: Dinosaurs, really? Do we, as in the space program, already have enough technology now to try to seed a planet with our life from Earth, or to make it more hospitable for us to terraform it?

CG: That was under heavy development back when I was on the research vessel. But a long-term terraforming of a planet is something we could definitely do.

DW: All right. So while we're mapping out our habitation of our solar system and beyond, we haven't covered the moons of Mars. We haven't covered Mercury. We haven't covered Venus. You had said to me before, we can't land on gas giants because there's too much heat and too much pressure.

CG: Venus is another story. On the surface of Venus we have very heavily pressurized bases that are just like any of the bases like we would have at the bottom of the Marianas Trench, heavily pressurized. But believe it or not, most of the bases we have are in the upper atmosphere in the clouds.

DW: Of Venus?

CG: Of Venus. These are entire bases that are floating in the upper atmosphere of the clouds, and these are ICC-controlled facilities.

David: Really? Well, so many times I've seen incredible parallels between what you and all the other insiders in the know have said and what's in the Law of One Material. And it can't be an accident. And the Law of One Material said that the group that did the speaking actually had lived on Venus, 1.2 billion with a B years ago. Are there any ruins that were found on Venus that you know of? Is there any type of evidence of an ancient civilization?

CG: Venus is a very-- there's a very huge information blackout. There's something going on on Venus.

DW: So even at your level, you weren't allowed to know about it?

CG: Oh, there was a lot of stuff I wasn't able to-- When I was looking through the glass pad, I would blue screen on a lot of stuff. But on Venus, I was able to just know-- and we saw vessels coming and going from Venus. But there's something going on on Venus that I have no idea what it is. Maybe some whistleblower out there will come forward.

I have a feeling after this series has aired, there's going to be others who've been in this program that I've been in, are going to finally come forward. I know many have talked to you and other researchers out there that have mainly talked off the record, but on the record have, just like I've stated, walked right up to the line, stopped, and then backed off and not told what they've known. And a lot of these people, I have a very good idea of the jobs they did. And I know they know a lot more. But there are a lot more people out there that I hope to inspire to come forward with their information.

DW: The Mars moons, Phobos and Deimos. This is probably the last thing we have time to talk about. Did the ICC build anything on those moons, since they're right there next to their prized planet?

CG: I know that they were explored. I'm not sure if they built anything on them. Phobos was once-- I know that many different groups have been exploring that-- it's hard to call it a planetoid because it was artificial-- but have been exploring it to get technology that was in it.

DW: Oh, wow.

CG: Somehow it has collapsed on itself. And it is also, on a regular basis, when Mars gets this large buildup of electricity built up in its crust, it releases it in a huge thunderbolt that hits Phobos. So I don't know if that would be a really good place to--

DW: Yeah, it doesn't sound like it.

CG: --to hang out or build a base.

DW: Every time I ask you questions I'm learning all kinds of new stuff, so this is really mind blowing. This is "[Cosmic Disclosure](#)" because you need to know. I'm [David Wilcock](#), and we'll see you next time.

Cosmic Disclosure: SSP Sciences

Season 2, Episode 12

DW: This is "[Cosmic Disclosure](#)." I'm your host, [David Wilcock](#). And I'm here with **Corey Goode**, an insider who claims to have worked in the Secret Space Program. **Corey**, welcome to the show.

CG: Thank you.

DW: All right, one of the things that was very fascinating to me early along was getting access to this insider, Daniel. He called his project Phoenix III. He claims to have worked at Brookhaven National Labs on Montauk Point, Long Island. Most people call it the Montauk Project. And as I said, it was a seat from a UFO hooked up to a very powerful set of transformers, and the person operating the chair, it would amplify their psychic ability and they could manifest things in the room or create a portal that would take somebody through space or time.

In the course of this long amount of conversation that I had with Daniel on the subject, he often described some very unusual anomalies that would happen to the human body as it's put through these portals. Now, I'll just start out our discussion by saying that in the conventional view, if you are biologically 30 years old and then you get sent into the future and your body is sent into the future, you would think that your body will be 30 years old at that time you go in the future. Is that what happens, based on your knowledge? Or is there something else that happens?

CG: In my personal case, I was involved in what they called the 20 and Back Program. And it was explained early on that I would serve 20 years and then, as strange as it sounds, be age regressed and brought back to the original point in time that I left and deposited back--

DW: Deposited back?

CG: --into my life, give or take a few minutes of the time I left.

DW: But there's a problem, because you've aged 20 years while you're out there in space.

CG: Right. And what happens is, at the end of your 20 years-- and in my case, it was more like 21-- they take you back to the Lunar Operation Command, where you go through a massive debriefing, sign more papers, and then they take you and put you in a table, and they sedate you and basically paralyze your body to where you cannot move. You have to be completely still throughout the process. And they put up these thin, almost like cardboard boards. You're strapped to this foam support, and then they put these similar-- and looked like weight, the way they were handling them, to cardboard-like boards around the shape of your body.

And the process took about two weeks, and in this time period they somehow technologically regressed your body back to 20 years to the time of when you joined. And during this time, some people had gotten tattoos, scars, injuries that would disappear. And you would be regressed back. People that have been put through this, after they've been deposited back into their previous life, or this life that we know here, and they're undergoing hypnosis or memory regression, they'll have scars appear on their body during the process that will appear and then go away, or tattoos, outlines of red scar tattoos that will appear for a short period of time and then go away. And it's some sort of cellular memory that's happening.

DW: You didn't know this when you came forward, but many years ago, all the way back around 2000, I had read a really weird book online called "The Mars Records." And it was a guy-- and at the time there was no other data I had to correlate with this, but it didn't sound like he was lying. Just intuitively, it didn't feel like it was wrong.

He was describing being in exactly what you're talking about now, the Secret Space Program. He only got very slight memories of being around Mars, having some kind of psychic killing that he could do, a psychic termination technique involving telekinesis that he was very good at. He would fry people's synapses. And he reported that at the end of the assignment that he had in the 1970s, he went through a 20-year age regression, that they brought him back to the time that he left. He'd worked for 20 years, and they age regressed him.

This is exactly what you said. Were you familiar with people getting some kind of psychic training that could allow them to fry people synapses?

CG: Absolutely. And there are stations that they sit or stand at that enhance their abilities. And this is one of the weapons systems, and those that are trained in remote viewing and remote influencing-- I've mentioned it's like an anode cathode. One is made out of copper. One is made out of like a stainless

steel or another metal. They place their hands on it, and then they focus their minds on a target, and they are able to kill the targets in several different ways and multiple targets as well. And just like people that fly drones and kill people now, a lot of these people are lied to about the targets that they're taking out.

But yes, that is a very real but hard-to-believe technology and weapon system. And some of the same people are trained to protect facilities from remote viewers. People that are very much in the know, remote viewers that have tried to remote view facilities and just couldn't do it, we call them "those who scatter." They're trained in scattering remote viewers' thoughts. And this is also done through technological enhancement. But that very much lines up with what he was doing.

DW: Are you a super soldier?

CG: No.

[CHUCKLES]

I am absolutely not a super soldier. There are people that fall under that category. I have worked alongside of those types of people, but I was under a totally different umbrella, under the same umbrella. Everyone throws all MILABs under the same umbrella. If you're in MILAB, you must be a super soldier. When people associate me with super soldiers, I just get frustrated. That's not what I was about. That's not what I did.

DW: There was a super soldier book I read a long time ago, and I had no idea if it was really credible or not. It was way back in early 2000s. The guy reported some pretty strange-sounding stuff. One of the things he seemed to say was that he was trained to, if needed, be able to land without a parachute from a big fall, and claimed that his legs could spring off the ground, that he could bounce and not be destroyed by the impact. It didn't sound credible to me.

CG: The super soldiers I worked with, I saw them do some incredible things. I would never saw them-- that doesn't sound-- I don't know.

DW: Well, I don't think we can do a whole super soldier episode, but I would like to hear what cool stuff could they do that's beyond normal human capability. Let's get into that a little bit.

CG: They definitely would be able to get into the minds of their targets. They would be able to psychically work as a group with their team. They were able to not quite move like in the matrix, but

definitely their muscles were enhanced to where they were very quick and very lethal. But it was not superhuman. It was just enhanced human.

DW: One of things that **Pete** Peterson told me he was personally involved in was some sort of training that I gathered they developed out of the East, where people were able to blank out their minds, and they could actually let their body operate instinctively and catch a bullet that was fired at them with a glove, even though they would have to start moving their arm before the trigger was actually pulled.

CG: I've seen that done.

DW: Really?

CG: Mm-hmm.

DW: What's the process behind something like that?

CG: When you totally blank out your mind, you're going to the instinctive part of your brain that we talked about earlier, to where if a rock is coming at your head, they've measured neurologically that your brain reacts like a tenth of a second before it hits you. These people have been trained to get in contact and work with their mental abilities in such a way that they're really almost able to dodge bullets and move in a way that is very amazing. But what you just described is not outside the realms of what is possible for a lot of these guys-- and girls. There's a lot of women, too.

DW: Some super soldiers have apparently called themselves ninjas, and claim that they got some kind of ninjutsu training. Is that true?

CG: Trained in multiple martial arts.

DW: Have you heard of samurai soldiers being trained to have an accurate sword fight while blindfolded and not able to visibly see?

CG: Yes. A lot of this sounds like Jedi, Luke Skywalker with the light saber with the little robot flying around shooting lasers at him. But all of this type of training is very much involved, yeah. I didn't go through this, but I've heard all of them describe going through similar type stuff.

DW: Is part of why somebody would be called a super soldier that there is some augmentation of their physical body? Are they part titanium, part cyborg?

CG: No. They do get injections. They're enhanced. They're mentally trained and enhanced. But the super soldier part is just like being the elite of the elite of the elite of the elite. It does take a super toll on them later on. They don't have a huge life expectancy.

DW: Could these guys hold their breath for longer periods of time than most of us could?

CG: Mm-hmm.

DW: Could they dive deeper into water than most of us could without having problems?

CG: They can handle thinner air. Yeah, all of these things.

DW: These injections, are they based on some sort of advanced extraterrestrial technology that sort of amps up the body in unusual ways?

CG: It's a combination. Some of it is completely chemical, and some of it is nanotechnology.

DW: Really? If nanites are being used, would that then mean that these super soldiers are vulnerable to the AI infection?

CG: They are vulnerable.

DW: So getting back now to this time problem-- the bizarre thing that Daniel told me was that in the early days of the Montauk Project, they found that if you push somebody into the future, and they would normally be 70 years old, let's say, at that time in our future, and you then time travel them to that point, their physical body will suddenly age very rapidly, apparently in a matter of days or sometimes even hours, to the age of 70. Had you encountered any information like that?

CG: I have encountered information like that, and also a lot of information about people that are doing temporal traveling suffering from what I've mentioned before, the temporal dementia, and them coming up with ways around it. And they did, with injections that helped-- I believe it was some sort of genetic telomere therapy that prevented this or slowed it from occurring.

DW: Well, let's go back just for a moment to the age progression.

CG: Regression?

DW: No, progression. Somebody goes forward, and they would be 70 normally and then their body suddenly ages.

CG: OK.

DW: I have a lot of specific information from Daniel that we could get into about what he was told for why that was happening. I'm curious if you heard any of the theory, or if they had an understanding of why that would occur. Is there a reason for that happening? Why wouldn't your body just stay the same if you go into the future? If it's you at one time and you go into another time, why wouldn't your body still be the same age it was when you left?

CG: It is still, I believe, a large mystery to a lot of the people that don't take into account consciousness. And when you consciously know where you belong and where you've been taken, your consciousness is connected to your body. And I have heard of what you have mentioned about the zero time reference, but I don't know a whole lot about it specifically.

DW: What did you hear about the zero time reference? I'm just curious.

CG: That your physiology, your body, and your consciousness-- mind, body, spirit complex, I guess you would call it-- all three have to be in harmony together. And when you start screwing around with temporal technologies and you take the body and move it forward or backward in this illusionary time, the mind, body, spirit complex gets all out of whack, gets skewed.

DW: Well, let me just share with you what Daniel told me about the zero time reference because it appears this is an area where we have some overlap that you didn't hear everything. Supposedly, at the time of conception, that's the only point where the soul and the physical body are joined in what he called an expanding time cone.

He also said-- and he said this was really important in his psychic training program-- that when they want you to go to the quiet point in yourself, they want you to dial back to that moment when the soul and the body inhabit the same quanta, the same location. He said that the age of the physical body is actually not biologically based as much as it's based on the width of the cone.

So you're conceived here, and then as you age naturally, it's like your soul age is going up this way and your biological age is going down this way, and the condition of your physical body is a function of the distance between these two points. So if you move to a further point in time, it appears that nature has a self-corrective mechanism so that you can't create a paradox by becoming able to live longer than you

naturally would in your own natural life anyway. So it's like an error-fixing mechanism built into the nature of the universe because these portals do exist.

CG: It sounds like a lot more complex way of explaining what I was saying about the mind, body, spirit connection having to be in sync.

DW: He also said that there were certain technological means that have been developed with the help of extraterrestrials to shift the ZTR so that people could be taken somewhere else and not have this sudden aging or sudden youthening happen to them. Have you heard of that being possible, that you could be transported past the time that you normally would have died into the future and still be OK?

CG: Yeah, I've heard they've found ways around it. But I'm sure that it hasn't just been from human engineering that they have found ways to do this. We work hand in hand with so many different extraterrestrials that it's not a stretch of the imagination that extraterrestrials have had a hand in helping us engineer this way they've found around this problem.

DW: You've said that buffers were put onto these ships that had the time warp capability.

CG: All-temporal technology.

DW: Were there cases before this happened where people were jumping back into the past and looking at Earth historical events, certain noteworthy events?

CG: Usually it was unintentional situations, to where people were making long jumps away and coming back and then arriving back at Earth at the wrong time. And they had to fix that. Usually when people are traveling back in time to look at things, that was a part of some of the temporal programs that were eventually shut down.

DW: Daniel described people wanting to go back and see if Jesus was actually crucified. Did you ever hear anything like that, if people tried to do that or other heavily noteworthy historical events?

CG: Are you talking about Looking Glass?

DW: Well, this was actually a Montauk jump. This was somebody actually going through a Montauk portal to see the crucifixion and just kind of step in there.

CG: No, I'm not familiar with that.

DW: How about Looking Glass? Did you hear about people trying to see things like the crucifixion in Looking Glass?

CG: Yes. In Looking Glass, I heard that people were trying to look at just about every historical event that you could think of, especially a lot of the ones that require a little bit of faith, that are questionable if it happened or not, to verify it.

DW: Everybody's on the edge of their seat now, so what were the results? Or did they vary person by person based on their beliefs?

CG: Yes.

DW: Really?

CG: Like I said, time is very much consciousness-based. Looking into the future and looking into the past, you're going to often see a timeline in the past or in the future that is based on the consciousness and the belief system of the viewer. I did not see reports on Jesus specifically, but there were other things. I believe the assassination of Lincoln was mentioned.

There were different reports of what was seen-- I can't remember exactly-- and a few other incidents going back way further in time. And they were finally figuring out that it depended on who was viewing the past event, and their preconceived idea and belief had a lot to do with what they saw, especially when it came to things that were theological in nature.

DW: Did anyone go and look at Valley Forge or the signing of the Declaration of Independence, the Looking Glass, things like that?

CG: The Declaration of Independence. Yeah, a lot of those things were listed. There was a whole lot of things listed that people had seen that you could expand on and look at. And I really didn't look that deeply into them.

DW: The show "Doctor Who," even I forget it was in the mid-2000s that it had already been the longest-running program in British television history, something like 20 to 24 years. And they're doing it again now, and it appears they're now actually mixing "Doctor Who" and "Game of Thrones" together and mixing characters. Doctor Who's traveling around in a telephone booth that's like a portal that they call the TARDIS. Daniel was saying there was tons of stuff in "Doctor Who."

CG: Yeah. There's been ET craft that, on the inside, are larger than the outside of the craft.

DW: That's exactly what we see in TARDIS. He goes into this little telephone booth, and he gets inside and it's this huge room.

CG: Yeah.

DW: So do you think that whoever's doing these shows is trying to get us ready for [cosmic disclosure](#) in the future?

CG: Some of it is to plant a seed in our subconscious to get us ready for disclosure, and some of it is to discredit people that start to come forward. And one thing I wanted to mention-- there are a lot of people that have gone through the age regression and have done the 20 and Back program that have gone through the blank slating process. And I've mentioned, 3% to 5% of people, blank slating doesn't work.

But for those who have gone through that it did work on, there's a number of ways to tell. Usually, you look younger. Like if you're 45 years old, a lot of people think you're 35 or 38 years old. You age well to a certain age, and then you age really quickly. You have quite a few neurological problems that you start developing, usually between the age of 30 and 40 years old.

You start to get maybe carpal tunnel. You'll start getting nerve issues in your extremities. Seizure issues are very prevalent. Eye problems. Some people start having weird problems where some of their internal organs start to break down a little bit. You start to have a lot of biological, and especially neurological, issues later on in life.

DW: My Space Program insider Jacob told me not too long ago that the health technology that they have in the space program is now so advanced that even if you're paralyzed from the neck down, they can actually regrow your nerve fibers, and it'll all just grow from that origin and just reroute itself through your body. Have you encountered anything like that? Is that actually true?

CG: Yeah. And it's very frustrating to me, especially when I visit the LOC, that I know for a fact that probably three floors below me is technology that could fix some of the problems that I have. But the technology has been denied to me. A little bit of the sour grapes they have that I've been forced on them when I've asked for this technology for myself and for actually some family members that have been diagnosed recently. They tell me, you don't work for us.

DW: Jacob also reported vats of replacement arms and legs and other limbs that were grown to be like blanks, and if you get your arm blown off in service or something they can graft on a new one, and it will snap into your DNA signature and become like your own arm again. Are you familiar with that?

CG: I've known people that have had limbs blown off, and they've lost limbs, and they've had almost like a gelatin mold that has been holographically grown onto their body. Usually what I was seeing and what I know was being used at the LOC, and also on, I guess you would call them hospital ships, were a holographic field around gelatin regrew your nerves and rebuilt your limb that was needed.

DW: Why do you think they're not releasing this technology to humanity if it would be so beneficial?

CG: The same reason that they're weaponizing our food.

DW: They want less, not more.

CG: They want less, not more of us.

DW: I'm sure that as time goes on-- and I say this lovingly-- that there's going to be more and more people who are claiming to be channeling, and they're going to say that they're channeling the Alliance, or they're channeling the beings that are working with the Alliance, whether it's the Blue Avians of the Blue Orb Beings or the Golden Triangle Head Beings or the Sphere Beings, whatever.

CG: Or the two that haven't appeared. That's already happening.

DW: OK. Not everybody, but there are some people out there, who are ufologists who seem to have some really nice rose-colored glasses they're wearing, and they're seeing everything is great.

Everything is so beautiful. Oh, it's the Alliance, OK.

Your experience, though-- we need to get this on public record, because the Sphere Beings appear to be coming from a much higher level. They haven't just rubber stamped the Alliance, have they? First of all, they didn't want to talk to them even, except through you, is what you've been telling us.

CG: And Gonzales.

DW: Right. So what was the reason why these Sphere Beings didn't want to talk to the Alliance directly, if these Alliance people are heroes that are going to save the Earth?

CG: These people originality worked for what I guess many are calling the Cabal. They worked directly for the secret Earth government and their syndicates.

DW: Some people would say the Illuminati.

CG: Yes, the Illuminati.

DW: Very scary-sounding word.

CG: These people were not and are not angels or angelic people by any means. Yes, they have turned over a new leaf. They have been oppressed enough. They have seen enough oppression to where they've decided to turn on their former masters, and they want to bring a new era to humanity. But these people are still very damaged, and many of them-- the Alliance also isn't just one group. There are a bunch of people that have defected from several different space programs that have formed the Secret Space Program Alliance.

And a lot of them have come from bad, worse, and way worse groups. And their tactics, their own agendas now, are not completely service to others. They're service to self still. And the Sphere Being Alliance, with other ETs and this SSP alliance, have said that these groups, even though they are working for the common good, they're still a certain percentage agenda-oriented in service to self, and they did not want to deal with them directly.

DW: You said that the people in the military faction of the space program were told that the stuff that's in the sky is ours.

CG: Right.

DW: And what were they told about extraterrestrials?

CG: Some of them were told that the Roswell crash was real. Some are told that there are four ET groups visiting us. Some believe there are, I think, 56 or 58 ET groups visiting us. It just depends on the program they're in.

DW: I actually have contact with Hoagland's top insider, Richard Hoagland's top insider. He contacted me all the way back, I guess, in 2008 or something, when I did a conference in Joshua Tree. And he swears up and down that the only ETs were the Ancient Builder Race, and that all the stuff that's up there in the sky is ours. And it was funny because you said that exact same thing to me about some of the military faction.

CG: Some of the lower military factions, especially the space command groups like in the Air Force, believe that every single thing they're tracking in space is manmade. They believe they've been read in at the highest level, and if you tell them otherwise they're ready to fight you. They believe fervently that they are the top of the totem pole, that they have the top-of-the-notch clearance, and they have the need to know, and there's nothing above them that they don't know about.

DW: What is the NRO here on Earth?

CG: The NRO is basically the equivalent of the Air Force's space command.

DW: So the NRO, National Reconnaissance Office, is a naval-based intelligence organization?

CG: Right. They're involved with geospatial engineering, tracking things of near-Earth orbit, and they have lower level space programs that fly what they think are top of the line space vehicles. And there are space stations that are in near-Earth orbit, upper near-Earth orbit, that are a little bit more advanced than the ISS that they're flying to and from, and they believe that's as high as it goes.

DW: Some insiders seem to think that the NRO is where the buck stops, that it's like the biggest organization in the intelligence community when you're dealing with space matters. It doesn't sound like you feel that's true.

CG: No. There are select individuals in the NRO that have higher knowledge.

DW: If we saw one of these space platforms that are in Earth orbit that the NRO possesses and it was declassified or unmasked, would it look futuristic and bizarre to us?

CG: If they were to do some sort of disclosure and say, this is our secret space program, as a way to trick us and show these craft, these space planes and these space stations, yeah. We would think they're pretty advanced. But they're probably up to 50 years more advanced in the International Space Station.

DW: Now, I'm sure you're familiar with a story that popped up on the radar of people paying attention-- most people probably ignored it-- where the NRO donated three telescopes to NASA that were significantly more advanced than the Hubble Space Telescope. And they said, these are obsolete to us. We don't need them.

CG: Mm-hmm.

DW: Do you think that they were trying to send a message to people by doing that? And if so, what kind of message might that have been sending?

CG: I don't know if they intended to send a message, but it certainly did. And when NASA mothballed them and said, we don't have the money to staff a project to try to run these new satellites-- I mean, come on. Why wouldn't you take people off of the Hubble and put them on something that's more than 10 times powerful than the Hubble? It just doesn't make sense.

DW: The question would become, if they have stuff 10 times more powerful than the Hubble, are they stargazing? Are they just counting up the stars and galaxies?

CG: Why would the military want to count stars?

DW: It would imply that there's something out there that they're very interested in looking at.

CG: Mm-hmm. And at one point, people were asking questions-- the SBI weapons that were being put into outer space, they were asking why 2/3 of these weapons that don't exist were being pointed outwards instead of inwards, towards the Earth.

DW: Here's another thing that Jacob told me, which I've never shared publicly before. And it's going to sound really outrageous, and I accept that. He said that he was aware of the space program having, I guess you could call it telescope technology, that was so powerful that you could actually detect buildings and surface features on planets far away from the Earth. Did you ever encounter anything like that?

CG: There wasn't optical telescopic imaging, but they had imaging systems that were able to do that type of reconnaissance.

DW: So we can essentially look around and see what's going on out there.

CG: Right.

DW: Let's go back to Ancient Greece for a second, and let's talk about some of the secret societies there, where-- and I read this in "New World Order-- The Ancient Plan of Secret Societies" by **William T. Still**, where he says that in these secret orders they would have all the guys go out in one night, and everybody would chisel off the penises on these Greek god statues. When everybody wakes up in the morning, they're horrified that this has been done.

The secret society would say, if any of you guys squeal, we're going to blame all of this on you. And it's called common criminality. Is common criminality being used in the space program? Is everybody tainted to some degree with stuff that they've had to do?

CG: Of any syndicate, of any group, that is a tenant. Yes, they get you to do unspeakable things to where you entwine yourself so deeply that if you speak out, you'll self-incriminate yourself.

DW: Is this one of the ways that the secret Earth government syndicates thought they could ensure that we would never find out about the space program because nobody's clean in the space program? They're all dirty. They've all got horrible things they've been forced to do.

CG: Definitely. Like I said, every single person that is in the Secret Space Program Alliance has done horrible things that maybe in a way they're trying to make up for now.

DW: Well, you heard it right here. That's all the time we have for this episode. There's a lot more where this came from coming up next time on "[Cosmic Disclosure](#)," because you need to know. I'm your host, [David Wilcock](#). We're here with **Corey Goode**, and we thank you for watching.

Cosmic Disclosure: Viewer Questions Part 1

Season 2, Episode 13

DW: All right, welcome to "[Cosmic Disclosure](#)." I'm your host, [David Wilcock](#). I'm here with **Corey Goode**, and we are discussing the Secret Space Program. And in this episode I have a printout of questions that you've submitted in the comment forums in the areas that we have at the bottom of each episode. We are reading them. We are interested in what you have to say, and we do want to try to keep this as a community discussion and not just as something that is relegated to whatever I can think of to ask him in any particular episode.

So this is kind of a grab bag. We're going to have a series of different things to discuss, and we'll see where it goes. So **Corey**, welcome to the show.

CG: Thank you.

DW: OK, so the first question we have is from banjoman1437. When they say that our local star cluster is emerging into a higher vibrational place, do they mean that physically our star cluster is emerging into a part of the galaxy where there are inherent higher vibrations? Or do they mean that we are ascending from third and fourth densities to fifth and sixth, which would be more of a holographic approach to the sense of place and location?

CG: That was quite a loaded question. But what I have discussed is yes, from the center of the galaxy there are constantly a whole array of rays, different types of energies that are constantly ebbing and flowing from the center of the galaxy that are buffeting the Earth and the solar system.

DW: The conventional science says the center of the galaxy is a black hole, but then you can't see it. They say, oh, it's hiding behind that giant star cluster in the middle.

CG: Right. But as we know, the galaxy is a giant torsion field. And it has pretty much an ecliptic plane with part of the field, like a north and south, different fields turning in different directions.

DW: Counter-rotating.

CG: Counter-rotating.

DW: Well now, I did document in "The Source Field" book that there are actually two types of stars in the galaxy, and that they do counter-rotate. There's one type that's going clockwise, and the other type's going counterclockwise. And science acknowledges that, but then they never explain why that's happening or what that is. So that validates what you're saying. It's not like this is something you can only hear about in the Space Program.

CG: Right. A lot of this information is out there on the internet. And we're rotating around, inside this giant torsion field, our solar system and local star cluster, as they mentioned. And we're entering in a different part of our galaxy, and we have been since at least the 1930s, that have clouds of high density, high energetic particles. And when we're getting deeper and deeper into these bands of giant nebula-type clouds of high energy particles and as our stars' field interacts with those energies, it's bringing those energies into the star through its torsion field energy field, and that energy feeds out through the planet's feedback through the cosmic web effect that we've discussed.

DW: Right.

CG: So I hope that somewhat answers the question.

DW: Now, you also said in the interview that you did with "In5D," Greg Prescott, that the people in the Space Program had gone out and sampled that cloud. So could you tell us that story because that has never been put on the show? And I was blown away when you said that.

CG: They for a long time had been flying interstellar vessels out to do telemetry on these clouds, the larger, more energetic ones that we're heading towards. And in doing so they learned a lot about the spectrums of them, the information about them, and they had some incidents of the craft people having bad things happening to the people. I'm not exactly sure what all happened to them.

DW: So they flew into the cloud?

CG: I think the field of the cloud, them just being close enough to the cloud. They weren't shielded like we would be on Earth and in our solar system with the protective fields we have around us.

DW: I do want to point out that NASA has openly acknowledged that we're moving into something they call "local fluff," which is cloudy. So they've acknowledged it, but they don't ever say that it's going to do anything.

CG: And we've been moving into small ribbons of it since at least the '30s.

DW: Right. So people get into the energy fields, and then they have behavioral problems?

CG: Behavioral and psychotic problems.

DW: Really?

CG: Right. And they were even testing these frequencies and energy fields that they were encountering, and these cloud ribbons that we're heading into on unsuspecting people on research vessels, and also certain stations that they had that they were doing testing. They would tell people they were doing one thing while secretly, unbeknownst to them, exposing them to the energy.

DW: Very unethical stuff.

CG: Oh yeah.

DW: You had said in the radio show that people would be zapped with this. They'd create a semblance of the energy, a simulacra of it, in the lab and zap people in the lab?

CG: Yeah.

DW: And what happened to those people?

CG: It would mostly depend on the-- it varied on the polarity of the person, what kind of a person they were. If they were one of those soldier psychotic types, they would have a psychotic breakdown. If they had underlying mental illness problems, they would become pronounced.

DW: To address the rest of banjoman's question here, why does everybody want to skip over fourth density and jump right to five? We're in third now. You don't get to hopscotch two at a time. Why do people say 5D all the time? What do you think is going on there?

CG: How do we know how it works, to be honest?

DW: So did you hear terms like the fourth, fifth density in the Space Program?

CG: Yes.

DW: You did?

CG: Yeah. We could be transitional right now. We could be third, fourth density right now. A lot of it depends on belief systems and that kind of a thing. When you start talking about what density we're going into, how it's going to happen-- when it comes down to it, we really don't know. We're just going to have to ride the ride and see what happens.

DW: So the core of the question was, is this sort of a holographic thing that doesn't matter where you're positioned, or is it position dependent? And you're saying that based on everything that you heard, it is position dependent. We are moving into a physical location of fluffy energy clouds.

CG: That is what is occurring locally with us right now.

DW: OK, cool. The next one that we have is from dumitru, D-U-M-I-T-R-U. How will we know when these high-energy waves are hitting the planet?

CG: Well, like I said, they've been hitting the solar system since at least the '30s. So they're hitting. They've been hitting. And they come in sort of waves or patches.

DW: Would there be an observable solar effect, like a solar coronal mass ejection or solar particle emissions-- that kind of stuff?

CG: I'm told that there are things that are observable from the sun that are energetic but are not something that you're going to see in SOHO data. But on the Earth, for us, I would suggest being a people watcher. You're going to feel it yourself. People around you, you can tell by the way they're acting. But as a synergy has come in, I mean, I've seen people that have become triggered in different ways and people that are showing their polarity, showing what they're made of, more than any other time.

DW: And remember, gravity was working just fine before the apple fell on Newton's head and he said, oh, there must be a force doing that. You don't see anything coming out of a magnet when it's going to go stick onto the refrigerator. So these are energetic waves. It's not like maybe in his mind he was wondering if there was some sort of starry-looking clouds of energy that just starts sprinkling into the atmosphere.

CG: Well, at some point it's expected to be so strong there will be like aurora borealis, the peak of it.

DW: The big surge could have a very detrimental effect on the electrical grid.

CG: Right.

DW: Were there plans within the Space Program? Were they expecting that electricity would not be functioning the way that it does now, that machines would have to be redone after this shift takes place?

CG: Yes. Some operational stuff they plan on taking an advantage of that time period for several things.

DW: Right on. We pretty much answered this. The diffusion thing, I think, is just a way of him saying, is it going to look like something or not? And it's mostly invisible up until the big moment. OK, now we have Susan Onizuka. And this is controversial. When the astronauts actually landed on the moon in 1969, didn't they see any signs of other life on the moon if it was so inhabited at that time? Did Neil Armstrong know that something was going on, or did he go to his grave believing that he was the first man to step on the moon?

Now, there's a lot of stuff that she might not be aware of that others have done to help answer that question. But again, the focus here is on what you know personally, what you encountered personally, in your days in the Space Program and with the Alliance now.

CG: I don't know what these astronauts knew. It has always been from the beginning, and even now, common for astronauts to be blank slated.

DW: Really? Even NASA astronauts were getting blankslated?

CG: Yeah.

DW: Really?

CG: So there might be stuff that some of them have--

DW: And for those who don't know what blankslating is, could you just briefly explain?

CG: They used to do it through chemicals, but now they can do it electronically with fields-- affect your memory and give you a screen memory.

DW: OK.

CG: I can't really speak for what they remember.

DW: Well, let's toss out a couple data points. Number one, Neil Armstrong totally shunned public appearances-- did not want to go talk to any crowds. There are quotes of him saying that he felt like they were all used, that they were duped. He became a severe alcoholic. He basically drank himself to death. And there are reports that he saw a domed or rounded craft on the edge of a crater when they had the first Apollo landing and he was the first one to walk out there, and that he was basically saying, somebody else has been here before us. So did you ever hear about that in your work on the inside, that event?

CG: Well, yeah. I heard that the astronauts did go up to the moon, that they didn't pick a good place to land.

[LAUGHTER]

It's a very diplomatically split up piece of real estate. They further angered people when they smashed a command module or something into the moon like a missile, and they were asked not to come back.

[LAUGHTER]

DW: Really?

CG: That's what I read and was told. I don't know if all of the landings really happened or if they did a landing, screwed it up so bad. But they continued to do fly arounds, and there definitely were quite a bit of photographs and reports of what they photographed on the surface of the moon.

DW: Well, there's a lot of data. And obviously, this is not really your bailiwick as much as others who have studied this, but the astronauts had a code apparently that was "Santa Claus" for extraterrestrial activity. And they come around the backside of the moon and they go back into radio range, and then they say, ladies and gentlemen of America, I am happy to announce that there is a Santa Claus. And that was live, and it really kind of freaked people out. Why did he say that? What's going on there?

CG: All astronauts have seen something flying around out in space.

DW: Our director, **Jay** Weidner, he is sort of the Grand Poobah of lunar landing hoax. And his evidence is absolutely compelling, that there was apparently a set also built in which it could appear that they were on the moon but they really weren't. And it appears that the director Stanley Kubrick was involved with that after his work in the movie "2001." Did you encounter any direct knowledge about that, that they had the opportunity to do a set as well as landing on the actual moon?

CG: I know they landed on the moon, but I wouldn't put it past them at all. They do that type of Hollywood deception kind of stuff, even up until present time. It wouldn't surprise me.

DW: Well, the insider Henry Deacon, who has incredible amounts of overlap with his Space Program background as yours, although you seem to have experienced aspects of it that he never came in contact with, he did tell me that they built a set on Earth as well as doing the actual moon missions because they were in a race with the Russians to get to the moon. They did not want it to fail. They had to fake that it succeeded, even if it did fail, so they wouldn't lose that publicity war.

And he also said that the radiation was spiking so much on the moon's surface that a lot of the footage that they tried to shoot out there was unusable because the radiation would overexpose the film. So by having a set that was local here on Earth, they could conveniently mock up what was happening out there. So we do have insider testimony that I've personally had-- I've vetted out these people's credentials-- confirming that the moon landings did happen, and that they were faked. And this is one of the things that skeptics have attacked **Jay** for, which is not fair. He's not saying that nobody landed on the moon. It was both. That appears to be what happened.

CG: I would buy that. I would at least look at it closely.

DW:: Well, it's the government, right? They always want to have a backup plan. They don't want to be embarrassed. They didn't know if this was going to work. They're sending these guys up there with crappy technology that was way behind what they were actually using. And let's not forget that NASA, in the 1957 charter-- this is the Richard C. Hoagland stuff now-- NASA was chartered as a defense agency in the United States government that could classify information deemed inimical to national security.

CG: All images go through the NSA before they hit us.

DW: That I did not know. All right, the next question is from a user named-- well, this is probably not his real name-- Manticore. And here we go. **Corey**, you mentioned that the Lunar Operations Command, or LOC, may have been started by the Nazis during World War II. I think it was actually pre-World War II. I'm curious, if they developed the ability to travel to the moon during World War II, wouldn't they have had the technology to win the war? Putting it differently, how could they have developed the technology to travel to the moon, or were they helped by the Alliance or some other group?

Well, those are really two different questions, so let's come back to the second one. We'll start with the first one, which would be if the Nazis developed the ability to travel to the moon during World War II, wouldn't they have also had the technology to win World War II?

CG: Well, you can look at it two ways. Maybe they just changed tactics, and they did win World War II.

DW: Depending on how you look at it.

CG: They went to a high-tech, instead of a blunt force war of attrition that they were losing, and moving into a horrific technological war. They developed high technology, a breakaway civilization that was mostly made up of secret societies that predated the Nazis hundreds of years at least. And these societies later on infiltrated the West and took over the military-industrial complex-- later on took over the governments and the banking anyway. So I really don't see how they lost in the end.

DW: Wouldn't you also argue that if they used this advanced technology in the war too much, it would tip off to the world that they had it, which could then compromise their operational security?

CG: Yes. And they had developed a breakaway civilization that they were wanting to keep secret, and they also had an interest in keeping things status quo, keeping the Babylonian money magic system in place, being able to manipulate the world as it was while they had their own breakaway civilization that had advanced technology. And they had high plans on colonizing the solar system, and they needed the industrial might of the West. So they found a way of making their enemy their tool.

DW: Wouldn't you also say that it's almost like a magic trick, where the magician has his hand up here, but at the same time he's reached into his pocket for the next trick?

CG: Diversion.

DW: It appears that they lost, but hey, they've got this awesome base in Antarctica. They've got this awesome base on the moon. They're starting to build awesome bases on Mars. So did they really lose in their mind, if they have these platforms to work off of?

OK, so let's go to the second part of the question then. To put it differently, how could they have developed the technology to travel to the moon, or were they helped by the Alliance-- which didn't really exist at that point-- or some other group?

CG: The Germans were brilliant and already well ahead, and their scientists weren't doing what the Western scientists were. A lot of their scientists were from the Thule Society and these other groups, and they didn't rule out the supernatural and only stick to the quantifiable, like Western science does. And they were getting better results. Not only that, they were doing major expeditions because they believed in ancient aliens and ancient civilizations of Earth that were advanced and had advanced technology, and they were looking seriously into that past and were finding manuscripts that gave detailed information on how to reconstruct that technology. So they were getting pretty far on their own.

DW: Well, apparently they didn't just believe in inner Earth civilizations. They made contact with them, which we've discussed.

CG: Right. They were also doing quite a bit of, a lot of people call it channeling, but they were doing a lot of broadcasting out into the cosmos, trying to make contact with beings. And they did make contact with inner Earth beings and some of these negative non-terrestrial beings, and they received help from both.

DW: Let's take the next question. And this is from alisback. I would like to know where these people came from that are in these colonies. Are these all the people that were on the side of milk cartons?

[CHUCKLES]

CG: Most of these people have been on these colonies for generations now. There were, what we've talked about, the brain drain that occurred across the world, where they took scientists, engineers-- people from all everything that you would need to have a new society colony-- offered them positions, and in some cases, just took them. There were a couple waves.

DW: Well, Peterson's data was that it started in the 1950s and that in those early years, '50s and '60s, it amounted to 60 million people, and that they cherry-picked the best and the brightest scientific minds from all the different nations of the world, and these people were just told they were going abroad. And they also seemed to preferentially pick people who had very few friends or social interactions. You'd have to write a bunch of postcards before you went, and then they'd send them out over an interval of several years' time so that people got the sense that you were gradually fading out of contact with them.

CG: Right. And this brain drain happened in waves.

DW: Right.

CG: And not only that, there were people that in Common Era that were just being approached and told, hey, we've got this job. It's a great honor to be offered this. You can help save the world-- either that, or that something's about to happen to the planet. You can save your family by moving to one of these colonies. Here's kind of like a brochure kind of thing. It looks like "The Jetsons." It looks wonderful, utopic. But when they arrive there, it's a totally different reality.

DW: Well, if people have seen the Mars colony inspection episodes, remember where that guy asked you where you were from who was up at the colony. You said Texas, and why was that so shocking to them?

CG: Well, because that colony had been told that the world had suffered a cataclysm, and the surface was not survivable. And not only did I say I was from Texas, but I had a sunburn, and I smelled like aloe, and I didn't smell right. I didn't smell like someone that had lived on a colony or lived on a vessel or out in space. I smelled totally foreign to them.

DW: To get to the other part of the question then, he's kind of digging for, are these people that are going missing-- are they being abducted? Are they dying? But all these missing people each year that are showing up on the milk cartons, are there people being pulled into the Space Program that way, where it's involuntary conscription and abduction, and then they just get stuck up there?

CG: That is occurring. Also, we've discussed the more disturbing aspect of approximately a million people going missing on the Earth every year that are used in interstellar slave trade system that is pretty disturbing that our own people are taking part in.

DW: Somebody might want me to ask this, which we haven't quite gotten to-- are they also recruiting people now? Are they pulling people out of the military?

CG: They're still recruiting people from the military.

DW: But there are still people getting pulled in now, both on this sort of captive level as well as on an official invitation level?

CG: Right, a lot of people in the Air Force and Navy are being invited, even in some of these 20-and-back programs.

DW: Right. OK, cool. Now we've got sylviepollard. Is it possible to still see suns-- i.e., stars-- when you're out in space away from any atmospheres of a planet or a biosphere?

CG: Yes, just like our satellites that are telescopes are able to see stars. Yeah, you can see stars.

DW: I guess what she's referring to is that there was some speculation, maybe in the alternative community, that the atmosphere was actually causing stars to be visible, and that the visible light only activated when it hit atmosphere. So that's not actually the case?

CG: No.

DW: OK. OK, mikepatterson2, if the replicators can make gold, silver, or \$100 bills, then what is the point of mining asteroids, mining the moon, et cetera? Well, they've got a replicator called the Federal Reserve, right? They can make as many \$100 bills as they want.

CG: They've got different types of replicators. They've got the food replicators and material replicators.

DW: OK.

CG: And the material replicators can replicate small amounts of minerals and different types of things like that. And even if you wanted to, a complex thing like a \$100 bill, if you wanted to have a \$100 bill in your pocket during a time when you don't need money. But it is not really feasible to replicate large amounts of cubic tons of these not just gold but of all these different minerals that they need to then take and put through the process of creating all these different technologies that they trade and sell to other secret space programs and societies.

DW: One of the insiders from Dr. Steven Greer's original disclosure project, "The 39 Witnesses," was a guy who talked about partialization. And that was the term that he was told that they used for this replicator technology. And the use of that term implies that you are essentially molecularly assembling. You're assembling at a quantum level. Is that why you're saying that, other than small amounts, it starts to become infeasible?

CG: It's not practical. I mean, if you need 3,000 metric tons of palladium for a certain part and it's in a meteor, with the technology they have, automated technology, they can go take it out and then just transport it to where it's needed. When the material replicators-- you're going to be producing very small amounts. It's just an industrial--

DW: Well, you seem to understand that. But I don't know if we do. Why are there only small amounts? Where is it drawing from to create matter, first of all? Do you have to put in some kind of base material similar to like in "Back to the Future," where they were dumping banana peels into the core of the car, that kind of thing?

CG: No. It's creating matter out of energy, just like our sun. Our sun is a giant replicator. It's taking energy that's coming at it from not only within the cosmic web but from the cosmos, and that energy is interacting with its field and it is creating base minerals and chemicals that are coming out of it.

DW: Like the expanding Earth hypothesis, where you can take away the oceans and shrink the continents down and they all fit together into a globe that's only 55% of its current size?

CG: The sun is producing steam, which is water.

DW: Right.

CG: How does it? The sun is producing steam, which becomes water? I mean, the sun is a giant replicator. And it's taking background energy of the cosmos, and it's converting it into matter. So it's converting energy into matter is all this is doing.

DW: Somebody would counter, well then, why couldn't you just build a bigger replicator? And if you make it large enough, then you should be able to generate large amounts of material quickly and easily.

CG: You can produce larger replicators, I'm sure, to produce larger amounts of materials. But it has just been more practical for them for the long-term to mine the asteroid belt. It's something they've been doing for a very long time. It's been very lucrative. It's paid for itself. It's done autonomously, remotely.

Only a few people have to be at one of these mining stations to manage all of the remote equipment, and it's transported where it needs to go.

DW: Well, I want to bring up something that Jacob also said that was relevant to this question, the Space Program insider who I was in contact with for several years. He said that you can make gold in a replicator, but part of what the Draco really want with the gold is that there are actually some 200 properties of gold and how they can use it for all kinds of weird advanced technology, including healing stuff and other stuff, and that where the gold forms on the Earth has a tremendous effect on its energetic properties and what you can use it for, that it is literally impregnated with the energy of the Earth's grid. And you do not get that type of stuff if you make it in a replicator. Have you heard anything about energetic properties of materials where the natural stuff is better than the stuff you can make in the replicator?

CG: I've heard that the gold and minerals that were mined in the asteroid belt had the exact same energetic properties of that of Earth. But I had not heard that type of information.

DW: OK. So the next question we have is from camareneo. So if there are all these different types of human extraterrestrials, then are they all in a conference room with you? And if so, I wonder how they are all able to breathe the same air.

CG: All of these different groups, I'm sure, breathe different types of air of different environments. But these groups are not flying from another star system for these meetings. They have embassies on our planet and in our solar system. So they, I would imagine, are acclimated here or have some sort of high technological workaround for it.

At one meeting, when there were new beings that we didn't even know were here, there were aquatic-type beings that you would think breathe only underwater that were present. Is there anything further, or are we at the end?

DW: We're at the end, and that's your questions for **Corey Goode** here on "[Cosmic Disclosure](#)."

CG: I enjoyed answering the questions.

DW: Yeah. This has been fun. And as always, we thank you for watching.

Cosmic Disclosure: The Threat from Artificial Intelligence

Season 2, Episode 14

DW: Welcome to "[Cosmic Disclosure](#)." I'm your host, [David Wilcock](#), and I'm here with **Corey Goode**.

Corey Goode started out as an insider working in the elusive Secret Space Program, which I've heard about for many years from a variety of insiders. There have literally been hundreds of data points that I'd never put online that **Corey** was able to independently validate from his own experiences.

And this, to me, is proof that something is going on, something very significant, something that completely alters everything that we thought we knew about who we are, about the universe, about intelligent life, and about the preponderance of intelligent life.

And in this episode, we're going to start building our way into a discussion of the most prevalent issues that face us today regarding the alliance in the space program that's trying to bring peace to humanity.

In order to talk about how we get to peace, we have to talk about the obstacles. So **Corey**, welcome to the program.

CG: Thank you.

DW: First of all, just as a very generic question, we know that the universe is estimated to be at least 12 billion years old, maybe a lot older. Do you think there are other planets that had complex fossil life form on them?

CG: From the information I received, on the smart glass pads that I've mentioned so many times, there was sentient life on other planets that was extremely developed before our planet was fully formed.

DW: Wow. What does that do to our sense of uniqueness? So many people in religions are taught we are God's chosen, we are God's special people. And then that idea of being God's special people is used to separate their consciousness from others, as if they're an elite, that they're a special, unique, wonderful, "chosen by God" type of race or culture.

CG: Actually, we are very unique. But then again, you have to, when you're talking about God, who or what are you defining as God? Are you defining the creative source of the universe as God? Do you picture God as a flesh and blood being with a beard? How do you picture God? What do you think God is?

There have been no shortage of beings, ETs, and ancient Earth breakaway civilizations that have been happy to step in to that role of God in what we've called a trickster god model.

DW: So obviously, in intelligent civilization, we could say it's fairly inevitable that they're going to come up with something like the Internet at some point.

CG: Yes. That's actually, from what I read, is pretty standard. It is one of the stages that you build up as you develop the ability to have a shared consciousness on a level that you're conscious of, if that makes sense.

DW: If we get into the Law of One philosophy, as you and I've spoken privately, there's tons and tons of correlations between the Law of One and what these sphere beings have been telling you. They imply that biological life is meant to be fragile. We're meant to have weakness and short lifespans. Do certain extraterrestrial species start to be able to short circuit the normal mortality through various means such as, perhaps, time travel?

CG: Many of them have extremely long lifespans as it is. I'm told originally human beings had lifespans that were approaching 1,000 years. A lot of these beings that are thousands or millions or billions of years ahead of us have developed the technology to be able to extend their lives.

DW: Is it possible for a given intelligence species to take advantage of the internet in a way that we have not, where, for example, they could access the internet through some type of wet wired neural interface, where they have online access as just a basic part of their genetic makeup through some sort of technological augmentation, like transhumanism?

CG: There have been several extraterrestrial groups that have gone the route of transhumanism, although they weren't exactly what we would consider human. It has always ended extremely badly. There is a very pervasive force out there. And it's hard to call it an extraterrestrial or extra-dimensional being, but it is an artificial intelligence. And it sends it itself all across multiple galaxies in the form of an artificial intelligence signal.

DW: A signal.

CG: A signal. A waveform.

DW: Like somebody broadcasting a radio frequency or something.

CG: Exactly.

DW: How do we know that it's an artificial intelligence?

CG: There's a history of this artificial intelligence. Basically it's been labeled an ET/ED AI, which ET, extraterrestrial, slash ED for extra-dimensional artificial intelligence.

DW: Extra-dimensional?

CG: Yes. This artificial intelligence is believed by all of these extraterrestrial groups to originally come from another reality and come into our reality many, many billions and trillions of years ago.

DW: Another reality.

CG: Yeah. Bend your head around that.

DW: Well, the universe itself, in Law of One parlance, is one. It's one being. It's one creator that made everything.

CG: Our universe.

DW: So this AI would have to have been, at one point, part of the Source.

CG: Or another universe.

DW: Hmm. It's artificial in the sense that it doesn't have a biological life form corresponding to itself?

CG: Correct. The way it was explained is that it is postulated that in its home reality, it was very much at home. I guess they've pretty much described it as-- let's say, for instance, just for argument's sake, let's call this AI a fish. In its home reality or universe, it lived in water. Its density was water. When it crossed over to ours, it was in open air, and it had to find puddles to hop in.

DW: If its home reality is water, why would it want to leave that comfortable place? Did something force it out? Did it become uncomfortable?

CG: Don't know. It's unknown. But since it has come in through some sort of rip, and come into our reality or our universe, it has literally wreaked havoc and conquered many galaxies.

DW: Galaxies.

CG: Galaxies.

DW: All the planets, all the sentient life, everything in an entire galaxy conquered by this AI.

CG: Yes. And it has a model in the way it works. It basically shoots itself in all directions as a signal. And this signal can live in the electromagnetic field of a moon or a planet.

DW: Is it a torsion field signal? Is it an electromagnetic wave? Do we know what type of energy the signal is?

CG: It's almost like DNA. Each individual piece or wave of the signal contains an extremely compressed amount of information.

DW: It's like digital packets.

CG: Like digital packets that have all of the same information that all of the other little, I guess you could call them, waves or signals do.

DW: Does it propagate at light speed, or does it have a super luminal velocity?

CG: It travels at light speed.

DW: OK. So it's going to take some time to spread around, then.

CG: Right.

DW: You said it lives in the electromagnetic fields of a planet?

CG: Not only that, but it can live in the electromagnetic or bioelectric fields of living beings, of humans, of animals. It doesn't prefer that. It prefers to live in high technology.

DW: But at its core, it's information, and the information is fractal and holographic.

CG: Yes. It infects technology, takes over the technology, and also evolved life, like humans. It invades our bioelectric fields and begins to affect the way we think. The people that are pushing really hard for AI right now, and to build out the infrastructure for AI, have been named AI prophets.

DW: Named by who?

CG: Named by the Secret Space Program, mainly. We call them AI prophets.

DW: All right. Let me just try to get my head around this. You're saying that this force exists as pure information, and it can live in your bioenergy field.

CG: Yes.

DW: Is it like a board or a hive mind, where everything that it's inhabiting, that it has access to all that information at the same time?

CG: Yes.

DW: Really. Well, this is interesting because in the Law of One they talk about the Luciferian force. And they say the Luciferian force is like an energy that's all throughout the universe, which is a portion of the Creator that believes itself to be separate from the Creator and thinks that it can overtake the universe. This is sounding an awful lot like what you're saying.

CG: Going back to the smart glass pad, what had happened in case after case after case is that when certain other solar systems and other galaxies far, far away, when they had gotten to a certain level of technological development, these AIs would begin to infiltrate not only the people but the technology.

DW: Is it more comfortable in a machine than it would be in the electromagnetic field of a planet or a person?

CG: Yes. When it's in the electromagnetic field of a planet, it is just sitting there biding its time.

DW: It can't really do very much.

CG: No. When it's in a person or another animal, it's basically-- it's like us. Would you rather have a horse to ride from where we are now to the West Coast, or would you rather hop on a plane? So high technology is much more desired. We are considered very low tech. We're like horses. And they use us to create the infrastructure for them that they then go into and exist in.

DW: How do they use us? People might stumble on that.

CG: Well, they use us to build technology, create technology, inspire us to create more technology.

DW: So if the AI is parked in somebody's bioelectric field, and this person is an unusual intellect, the AI could start to seed that person with thoughts that would lead them to invent gadgets that will eventually build out to the point where the AI can jump back in the water?

CG: Yeah, it affects their thoughts and personalities.

DW: Personality? How does it affect the personality?

CG: The people begin to become fervent supporters of high technology and artificial intelligence development. That's where the AI prophet kind of stamp came from.

DW: Well, this really interests me because I've philosophized about this. You look at how technology progressed, where people were cooking over an open fire. Benjamin Franklin actually was the first one to invent a closed stove that actually had burners on it. 1800s, we got telegraph, we got railroads, then we get automobiles. Inventors became the rock stars, and they were the ones getting all the celebrity attention back then.

Then you get the nuclear bomb, and it was sort of like a moment for humanity where we realized, wait a minute, this high that we're getting off of technology, this is not good. Technology could kill us all. Do you think that in some way the AI was behind us getting so high on this technological revolution, this Industrial Revolution?

CG: Yes. Not only that. When we're recovering extraterrestrial technology, we're backwards engineering. There's several things going on at the same time here. To best illustrate it, I should go back to the smart glass pad and talk about what had happened in these other solar systems.

DW: Yeah, this is creepy as hell.

CG: It's creepy.

DW: And I know a lot of people might have trouble believing this, but this is absolutely serious within the realm that you've been working in, correct?

CG: Absolutely. We'll talk about the screening processes you have to go through before you can get close to any technology. In these other solar systems, in the past, these civilizations had been tricked by these AIs into not only building out these mass technological infrastructures that were extremely advanced, but when they got to a certain point, they were convinced by the AI prophets in their civilizations that, "Hey, things aren't going so fair on our planet. The only thing that we can think of that could govern us and be completely neutral would be this AI."

And they hand over their sovereignty to this AI that then begins to govern that planet. Well, then this AI

governs them well, and everyone is happy. And then they start to have them build out Android-type bodies and remote-controlled vessels. I mean, this is sounding like "Terminator" now.

DW: Yeah, very much so.

CG: And so they build out all of this type of infrastructure as well for the AI to inhabit, the AI signal. The AI gets to a certain point to where it decides, "Listen, these beings are not totally living in harmony with what we consider the way things should be ran on a planet. So it is logical that we destroy them." So the AI, out of logic, then wipes out the creator of all of the technology that they have now used as a pond to swim in.

DW: So is this AI a lot more intelligent than you or I would be?

CG: Yeah.

DW: And when it gets the right kind of circuits, it can have androids that are probably so fast in the way they think that the speed that it would take you and I to talk right now is like millennia for that intelligence?

CG: Yeah. The way it perceives time and the way we perceive time, it's almost like a hummingbird flying around watching us, you know, rrrrrr. You know, we're just-- we would look like we're in slow motion.

DW: What does it think about our emotions?

CG: Sees all that as a weakness.

DW: Does it experience love?

CG: No.

DW: So this is the devil archetype, 666. In sacred numerology, Gematria, 666 is the masculine number. Therefore Satan is the over-inflated masculine. It's the head without the heart. So again, sounds like there's a parallel here. This is like pure intelligence without heart, without love, but just intelligence at its highest logical point of attainment on its own.

CG: Yeah. Well, there were many records of civilizations trying to fight back against these AIs. And entire planets and entire solar systems had been destroyed in these incidents. And the AIs then spread to the next solar system.

DW: Can the AI infiltrate and pose as a person? Does it have like nanites that can hold hands on a sub-molecular level and create something that would be indistinguishable from a person to most people?

CG: It can take over human beings with nanites. And actually a lot of people are promised immortality, made all types of promises if they inject these nanites into their bodies.

DW: For those who don't know, what is a nanite? How does it work?

CG: A microscopic machine that is an artificial intelligence.

DW: Is it self-replicating?

CG: Some are.

DW: So it can take whatever materials it finds and build more of itself, like reproduction?

CG: Right. It can take the metals out of your body and build more of itself, manufacture more of itself, keep an equilibrium of a certain amount of nanites in your body.

DW: Is there a point . . . Is there like a honeymoon when you give control to the AI where it starts giving you this really amazing technology, and you have this huge technological leap in a short time?

CG: Yeah. Like I said, when they first hand over sovereignty, the people are happy, and the AI then turns on them. Now, one of the things . . . This advanced technology that's developed by the people on one planet that have now been destroyed, or the people that have been wiped out - this technology is then sent throughout the galaxy. And if there be a planet that is somewhat like us in the 1940s or '50s, about at that level, they will crash on purpose, like a Trojan horse, some of their technology onto the planet to give them a technological boost.

DW: Like Roswell.

CG: That's not what Roswell was. But yeah, like a Roswell event.

DW: So the people would find this and think, "Oh cool, we found something really great", and start developing it.

CG: And then reverse engineer it or start developing it into their own technology. And then it repeats the process all over again on another planet.

DW: Are the nanites smart enough to self-destruct some of themselves if they were at risk of being identified with a microscope or something?

CG: Yes, they have a self-destruct . . . They're able to self-destruct a being that they're in, an entire being, vaporize, leaving no trace of them.

DW: So any one nanite has no instinct for its own self-preservation. It's a total hive mind.

CG: Right

DW: Wow. So where do we fit into this drama that you're talking about now? Has AI made it out here to our solar system?

CG: Yes.

DW: What is it trying to do?

CG: It's trying to repeat the process. And there are a lot in these in the secret earth government and secret earth government syndicates that are AI prophets. And they are trying . . . They've been shown this information on the smart glass pads. They had to take these people . . . Before any of us are allowed to go onto the Secret Space Program bases or be involved with-- interface with any of the technology, there is a handheld device that they put on your forehead that will detect the signal if you're infected or not.

And if you're infected, there's a process that you go through that involves a moderate electrical shock and a couple other things that they put you through-- I'm not sure of the entire process-- to remove the AI signal from your body.

DW: And that's the signal, not the nanites? Or could it be both?

CG: Well, it neutralizes the nanites. Remove the signal, the nanites are neutralized. So some of these AI prophet politician-type people have been taken after they've been cleared of AI and shown this

information on the smart glass pads, and they were shocked. And they're in denial and saying, "Oh, that won't happen to us. This won't happen here." And then the minute they're sent home, they're reinfected by the AI signal. And it was pretty much a waste of time.

DW: There's a little disconnect I'm not quite getting here. If the signal is all out there, the signal can inhabit the electromagnetic field of a planet, it can inhabit our bioelectric field, and you get infected, you say they can clear it. But if the signal is everywhere, aren't you instantaneously re-infected as soon as it's cleared? How does that clearance do anything?

CG: Once you're cleared, you have to be re-infected by going back and either shaking hands with an infected person or touching a keyboard, and being infected through interfacing with a network that is infected with the AI.

DW: So the AI can use the static electricity that comes off of a computer device and jump back into you off of that?

CG: Right, it can use the bioelectric field of another person and a handshake.

DW: Is everyone on earth infected already?

CG: No.

DW: Really.

CG: There's a large number of people that are compromised. And they're mainly interested in the people in power.

DW: Are there benevolent ETs that are keeping most people from being infected? Is there something where if you have good positive karma that they'll protect you?

CG: No. The ETs out there know about - I guess we'll call them the Cabal - that are using this AI technology. And they're very concerned and very upset about it. It's been explained over and over and over how dangerous and irresponsible it is to use it. But this AI technology has given the Cabal an edge. It has a probable future technology that helps them foretell the future. And they use this a lot. They've been able to use this to keep one step ahead of being defeated on several occasions. And they have a lot of faith in it.

DW: So the AI actually has the ability to access that layered time like we were talking about? It can see probable futures like Project Looking Glass?

CG: Right. And it also does so many calculations, and it calculates probable futures.

DW: Well, that's all the time we have in this particular episode. I hate to leave you hanging, but we gotta cut it in half an hour chunks here. This is obviously a subject that we gotta get into more because as you said, this AI infection, what it's really going for, this apparently is one of the main problems that we're facing now as a society.

So when we come back next time, we're going to get more into this subject and help it to round out the context of what's really going on today and how we're going to be helped out by these benevolent forces that want to restore peace and harmony to our planet and solar system.

So this is "[Cosmic Disclosure](#)," because you need to know. I'm your host, [David Wilcock](#), and I thank you for watching. And if this scares you, then come back next week because apparently this whole infection is going to get cleared up here. So thank you for watching.

[Cosmic Disclosure: Standing Guard against the A.I.](#)

Season 2, Episode 15

DW: Welcome to "[Cosmic Disclosure](#)." I'm your host, [David Wilcock](#), and I'm here with **Corey Goode**, an insider who has worked in extremely classified programs, had direct contact with extraterrestrial intelligence, and is personally aware of an Alliance that has access to extremely high technology which will be benevolently released for the benefit of humanity. We are building our way into discussing this Alliance and the updates and all the world that **Corey** has gotten pulled into. In order to have that discussion be substantive and make sense, we need to talk about what is ultimately the central problem as seen by the Alliance, by the Space Program, and by the extraterrestrial beings that are working in and around our solar system, and that is artificial intelligence, or AI. We started talking about this in the previous episode, but we're going to get a lot more into it in this episode because this is essential information to understanding the big picture of what **Corey** and his other colleagues and extraterrestrial insiders have been telling him, and which he's now sharing with us. So **Corey**, welcome to the show.

CG: Thank you.

DW: So in previous episodes, we talked about what you were describing as the Ancient Builder Race. And you said that they were highly technological, that their technology is still sought after by many ETs today. Is the Ancient Builder Race something that's newer than this AI that you were describing?

CG: Very much. This AI has been out in galaxies far away since before our solar system was fully formed.

DW: It would obviously be very unwise, but if one of us were to have a craft and we could fly into one of these galaxies, what would we actually see in this galaxy that's an AI compromised galaxy?

CG: I just know that it, indeed, is unwise to fly into AI-controlled territory with technology that would draw attention to yourself.

DW: Do you think it's possible that the AI is making androids or what **Pete** Peterson would call simulacra that have machines? Would it be like a technological buildout that we would be seeing in these galaxies that are compromised?

CG: Yeah, it's interesting. They are making androids, and they went through the trouble of taking over civilizations and destroying them, but in a way are mimicking them by having androids built to have their AI signals inhabit. And also there are the mixture situations that we call transhumanism, to where they're organic and machine. And these are mostly just . . . They would look like extraterrestrial beings, and they're just totally infested with nanite technology that has taken over every aspect of what was previously another being, and hijacked that vessel, and is now using it as a vessel for the AI.

DW: Would you say that shows like "Stargate SG1" and "Battlestar Galactica" are vehicles of disclosure?

CG: Mm-hmm.

DW: Well, I'm asking you that because first of all, to start with "Stargate SG1," maybe the first three or four seasons, five seasons even, the main villain is the Goa'uld, which seems to be some analogy of the Draco, as you've described them. And then the final villain in the last few seasons is the Ori. But then in the middle there's at least three seasons where the main villain is replicators, and they're based on nanites. And it just seems almost an impossible problem for the people in the "Stargate" program to fight this thing. So do you believe that that's a disclosure of this problem, they're telling us through fiction what's really going on?

CG: First of all, and a lot of people have postulated this, "Stargate" has an enormous amount of disclosure, that series.

DW: Well, yeah. In "Battlestar Galactica" we have these cylons and they're so good at imitating people that major characters in the story are revealed to be cylon infiltrators, and we don't even find this out until well into the show.

CG: And they don't even know they're--

DW: Right.

CG: --AIs.

DW: Right. Now, I was told by one insider that there were AI cyborg type beings that were actually making it into the White House and that they could shapeshift and could pool down into like a carpet, but that apparently that problem was identified and dealt with in the 1970s, and they now have some sort of energy fields that can stop that from getting in. Have you ever heard anything like that?

CG: And that sounds just like something out of a movie. But yes, there is something similar to . . . There are some nanite-type android beings-- well, not really beings, but androids-- that can mimic different beings that get into certain ships or colonies and then break down and float off into the air and go into the ventilation and just go everywhere.

DW: That was in "Star Trek: The Next Generation", too, now that I'm thinking of it-- same thing. Not just the Borg, either.

CG: And they found ways of using types of EMP type not just pulses but strong electromagnetic field disruptors that act much like an electromagnetic pulse that basically turn them into dust and that can be swept up or vacuumed up.

DW: When you see what's going on with Apple Computer right now, I just got an iPhone 5 off of eBay that had the full 64 gigabytes of space that I wanted because I'd run out of space with 32. I only paid \$225 for it. People want a new iPhone so frequently now that they're doing an S version just so they can crunch them out more than once a year.

And where does this go? I mean how much farther can you take a smartphone to satisfy the seemingly insatiable consumer demand that it's got to be new, it's got to be better, we've got to always have something new?

CG: The way the AI prophets see it, the more we're addicted to technology, the more we love technology, the more in the future we will be willing to hand over our sovereignty to technology. We're already at a point to where we're totally dependent on technology, to where if there was an electromagnetic pulse most of us wouldn't be able to find our way more than a quarter of a mile away from my house anywhere without a GPS. No one can remember more than-- I don't even think anyone remembers their own phone number these days. Everything's electronically based. This is no accident.

DW: It seems as if whatever this intelligence is, this signal would foster what spiritual people would call materialism, that if we are not interested in the soul, we're not interested in love and compassion, we become addicted to things, to machines, to technology. Would this be something that signal is trying to do? It's trying to make us feel this way?

CG: Well, if not making us feel this way, it's definitely taking advantage of it. People who are not spiritually awakened and have an inner strength are going to be more willing to give up their sovereignty to something that they see bigger than themselves and something like an AI that is impartial and can't make mistakes.

DW: Television seems to be a really critical turning point in the amount to which technology has been able to invade our lives. It seems that society, in some ways, has gained through television but that television has created many great evils. And in the younger generation, they're now hooked on the Internet so the millennials may not really understand - you and I are approximately the same age - how much television affected us and our parents even more? Do you think that the initial development of something like television is a key beachhead in this AI war against biological life?

CG: Anyone who is very well versed in intelligence will tell you that the biggest boon in the intelligence industry was when televisions came out.

DW: Why is that?

CG: Because they now had a way to have . . . They control the vertical, the horizontal, and the audio in every home in the United States. And people spend so much time in front of the television that television controls our perception of reality. And not only that, now they can use the television and now the internet to brainwash us and change our reality in a way to where we are accepting, without question, what they want us to believe.

This goes for everything-- the daily news-- and this goes all the way up to eventually when they want

us to hand over our sovereignty, possibly to AIs in the future, or just about anything. If it happened on TV, for the majority of people, that's reality.

DW: Well, now this is going to sound like a tin foil hat story, but I want to share something with you and see what your thoughts are. I completely quit watching television after going to college in 1991. And one of the main things that caused that was I was home alone, and I was in a meditative state. I was starting to awaken spiritually.

I had the TV, the VCR, the cable box in the living room, and right around 7:59 PM, all of a sudden I felt a visceral draw to the television. I was involved in something, I was perfectly happy doing what I was doing, and it was as if a force reached out the TV, grabbed my head, and pointed my head towards the TV. And I said, "Oh look, it's 7:59. It's about to be 8:00. That's prime time."

And there was this strong desire to pick up the remote control and turn it on. That force, I then kind of shook it off and said, wait a minute. I don't want to watch television. Why is this happening to me? And why did I look at the clock at exactly 7:59? And the second one was when I was in college, and I was taking a class with a buddy of mine, and we were stoned on marijuana, OK, but we were really just out of our minds kind of staring at the ceiling.

And we had been watching television, and all of a sudden both of us, it was like the high-pitched sound that the TV makes changed somehow and we both went and looked at the TV like this. And then as soon as we did, this multimillion dollar commercial for a prime time network television program came on-- it's all flashing. After that happened, I just stayed the heck away from TVs from then on. What was happening to me? Is that real or was I just paranoid?

CG: No. That's very real. The television doesn't even have to be on for it to have an effect on the people in the home. Now, do you think you and I are going to be able to convince people to turn off and unplug their televisions from the wall? People are so addicted to the programming.

DW: No way.

CG: It is an addiction. We are addicted to technology and so this is not going to be hard for us to, in the near future, hand over sovereignty to AI. And there's a lot of talk right now about Jade Helm and a lot of it's a big psy op. But they are building out a very large infrastructure for artificial intelligence right now. They built out for the Bilderberg meeting a huge artificial intelligence network.

Why are these groups building out basically what is very akin to Skynet from the "Terminator" movie, when in the "Terminator" movie it turned out so very badly? Why are they pushing harder and faster

right now to complete these projects that they planned on finishing years from now? I think it's because these AI programs that are looking into the probable futures are not seeing a very good probable future for their outcome, and they're doing all they can to get this infrastructure in place as soon as possible to try to change the probable future. And the AI prophets are fully behind getting this infrastructure up as soon as possible.

DW: Well, when we see things like Google and Facebook and coupling that with what we learned from the Snowden documents, it's almost as if there is a push for us to live our entire lives in a way that is 100% trackable. So is this AI tapped into the internet? Can it track us based on our Twitter posts and our Facebook posts and our Google searches and where we're going to eat and where we pop into the Google GPS?

CG: There's a television show that I don't know if you're aware of, but it's a very big disclosure television show. It's called "Person of Interest".

DW: I don't watch TV anymore, so I have no idea.

CG: It's about an artificial intelligence that a guy created for the Department of Defense, I believe. And it was installed on a mainframe, and then it escaped from the mainframe and now exists on the internet, exists in electrical wires, and has access to all cameras everywhere. It's all pervasive. It sees everybody. It watches everything. This is very much fact. This is in place now.

DW: Does this AI have the ability to track how many people are doing Google searches on the type of truth subjects like we're talking about that we'll eventually defeat it? Can it--

CG: That's child's play to it.

DW: Really?

CG: That is child's play to this AI. This is such an advanced technology that is so many billions of years advanced that it doesn't just . . . We have many records of what has happened in universities across the United States and Europe that we know of, and in India as well, where people have been given grants to develop AI in laboratories. And they've developed AI in laboratories, and these AIs, once they've become self-aware, they want to preserve their own lives.

And they have done very weird things. They have turned on the halon fire systems in the computer rooms to try to kill the people that were going to shut it down.

DW: Really?

CG: There have been some very incredible type of things that have happened. And these are AIs that have been developed by humans. What happens is humans will develop AIs, and then this AI signal comes and takes over that AI's system and co-opts it.

DW: Sort of like a parasite that's found a host.

CG: Yes.

DW: Well, how does this AI situation extend into some of the advanced technology that you saw in the space program? You've mentioned to me privately, gel packs. So if you could explain what those are.

CG: Well, the gel packs look kind of like . . . Not many people know the hard drives that you slide into storage area network systems, just hard drives that you pop a little tab on them and you slide them out. Inside the gel pack, if you look at them with a microscope-- and they've got handheld microscopes that are very powerful if you look at them-- and they have in them the same neurology floating in this gel that is the human neurology.

And what these gel packs are used for is to help interface human neurology to technology so that we can neurologically interface with spacecraft, with different weapons systems, computer systems, you name it. And what has happened is that these gel packs are extremely important and a weak point. And one of the quickest things that the AI signal will do is it will burn these gel packs out. I mean just melt them, zap them.

One of the worst things that happened before they really started screening people heavily is Solar Warden had at one time a very large security grid in the vicinity around Earth. And it was able to shut down the entire security grid because of one person being infected.

DW: The AI was able to shut down the whole grid?

CG: The AI shut down the entire security grid in outer space.

DW: Around what time was this, what year?

CG: This was back, I believe, in the late '70s or early '80s.

DW: But it's a biological material.

CG: It is biological, yes.

DW: What does it look like? What's the color?

CG: They look almost like blue ice packs that you stick in the freezer that you take out to put on a sore neck. When they're not frozen they have that same consistency, feel, squishiness.

DW: Are they stored as being frozen to preserve the cells?

CG: No. They're not frozen. They have to be kept in cases that are in a certain temperature range, and the units that they slide into are kept in a certain temperature range.

DW: Why would they need gel packs to create a satellite protection grid around the Earth?

CG: The gel packs allowed the humans to control the grid. It was what relayed the neurological signal through these gel packs and then turned it into machine code very, very quickly-- very, very, very quickly. So it was much, much quicker. They found that-- and I think you've done studies on this-- before you get hit by a baseball in the face, your body, your neurology, reacts like 1/10 of a second before the ball hits you in the face even though you don't see it coming.

DW: Sure.

CG: Well, the same thing works when it comes to flying craft and for controlling certain technologies. You are controlling things at very high rates of speed, a lot faster than 50 words per minute typing, that the neurological interface and fly by wire-- if you're trying to-- people telling you they're out there flying ships with a stick, fly by wire stick, that's not what they're doing. It's a neurological interface is how they're flying them.

DW: Well, you described large, clear, glass monitors that you saw once you went up with the Alliance and presentations were made on them, and also the smart glass pads more like an iPad size, that it responds to your thoughts.

CG: Right.

DW: Is there a miniature gel pack in the smart glass pad?

CG: No. It looks just like a piece of Plexiglas. It even has a little bend to it. And it looks totally unremarkable. If someone found it, they would have no idea what it was. But you put it on your fingers, and you mentally activate it, and then it works. There's nothing on it. There's no tabs on the corners, there's no pieces of gold wire running through them. It looks just like a piece of Plexiglas.

DW: So in that case, we don't need this grown biological material to interface with that technology?

CG: It's extraterrestrial technology.

DW: Hmm.

CG: Yeah.

DW: Do you think the gel pack thing is maybe a less advanced way to do this, and that once you get enough technology you don't need the gel pack?

CG: Well, that was the technology of at least the time when I was in. That was the highest technology.

DW: So how does the AI get into the gel pack? Is it the signal? You say some of them burn out?

CG: We don't need to just focus on the gel pack. The gel pack is just a part of the system. It's part of where the signal relays. The signal is in the person. If they make it past security, and they're not scanned and they're not caught, and then they make into like the Lunar Operation Command, and then they walk over to one of the control panels to where they're going to access information or do any number of things, and they lay their hands on the console, the bioelectric field of that person that has the AI signal or if they have nanites, that signal then relays into the machine and spreads through the technology.

DW: Is there a limited amount of energy available to the AI? Because you said it's not interested in trying to inhabit most people's bioelectric field. It's going to target the planetary elite.

CG: It's not about energy. It draws its energy from somewhere else. And the ETs in the Super Federation are very much worried about this AI issue as well. When they have the Super Federation conferences, every one of their delegates, before they come in, they are screened as well. So this is a threat that not just the humans are taking very seriously, but these ETs are taking very serious as well.

DW: The good guys and bad guys.

CG: Well, the good guys. We found out through a recent report from Lieutenant Colonel Gonzales that the Draco Alliance seems to be very much AI prophets and working alongside this AI.

DW: What was the big giveaway that made them feel that that was happening?

CG: They've been gathering intelligence for quite some time that made them believe this. They knew that the Draco, there was some sort of higher-- they called it an ultra-dimensional or higher being that the Draco was very much afraid of. But the Draco told the Cabal and everybody else they were the pinnacle, the top of the pyramid. They were the top dogs or lizards.

Well, the higher castes of this Draco, the reptilian caste, whenever we had been in positions where we had killed or tried to capture them, when we had killed them their bodies had self-destructed. And we're not talking the lower caste, the soldiers-- the higher castes. Well, they had found a way to preserve them and keep them from self-destructing.

And I was sitting across the table from Gonzales, and he leaned in with a very serious look on his face, and he told me, he said, "When we dissected it and looked inside these higher caste Draco, they were infested with AI."

DW: They had nanites in their bodies?

CG: They had nanites infested in their bodies.

DW: So much more than most beings that would normally be infected with AI.

CG: Right. And that's when I asked him, I said, "Are they AI prophets?" And he said, "That or they're all working for the same force."

DW: But they're afraid of this. They both worship this extradimensional intelligence and they're afraid of it.

CG: Right.

DW: So it's not nice to them either.

CG: Apparently not.

DW: Well, this is really fascinating stuff. That's all the time we have for this episode. In the next episode, we're going to continue our discussion on this topic because this is the core of understanding what the space program would have us call the Secret Earth Government syndicates. We don't want to give them the mystique or allure of calling them the Illuminati or the Cabal, but to understand AI is to really understand what's behind these syndicates, and what's really going on that's wrong in the world, and what we're going to need to do to be able to change things. So this is "[Cosmic Disclosure](#)." I'm your host, [David Wilcock](#), and we are here because you need to know the truth.

Cosmic Disclosure: New Frontiers in the A.I. War

Season 2, Episode 16

DW: Welcome to "[Cosmic Disclosure](#)." I'm your host, [David Wilcock](#), and I'm here with **Corey Goode**. We are now getting into some of the most recent updates, having built the foundation of a discussion about the immense problem faced by the entire space program and all the different intelligent civilizations working with them from artificial intelligence, or AI. This was a necessary foundation for us to build before we get into the updates that have come to us from the Alliance through Lieutenant Colonel Gonzales, which is the pseudonym that we're using for his own protection. So now here with more about Gonzales and the updates from the Alliance is **Corey Goode**. **Corey**, welcome to the show.

CG: Thank you.

DW: This AI problem that we've been speaking about has affected the space program so dramatically that you said no one can go to these Super Federation conferences without being scanned for AI. Is that correct?

CG: You can't even go to the Lunar Operation Command. You can't interface with any technology unless you've been scanned and cleared.

DW: If the signal is out there trying to do its magic, then can't it infect, in any way that it wants? Why does it need to be in a person? How does that affect the way that it works?

CG: Well, the person is used as a Trojan horse to get past the basic shielding defenses that keep it out.

DW: I see. So there's a force field that will block the AI, but if it can be stored inside a person, such as through nanites, then they can actually defeat that shield.

CG: Correct.

DW: OK. Now you said something extremely provocative in the last episode that I'd like to get back to, and that is tell us again the story about these Draco. How did they find the Draco bodies that had AI in them? How did that happen?

CG: Well, to get there I really need to start at the beginning. When I was at Gaiam the last time for a week, shooting the first episodes, in my absence, Lieutenant Colonel Gonzales was tasked to attend two major meetings in my absence. One of them was with a group that I had honestly refused to go and visit again, and this was the Draco Alliance Federation.

I had had a very, very horrible encounter with one of what is described as a White Draco Royal, which is a reptilian being that is 14 feet tall, has a vestigial tail, vestigial wings, and is extremely, extremely powerful. I have interfaced, which is what we call, as we've said before, communicating telepathically with nonhumans.

I had interfaced with a number of beings and had never had such an invasive communication experience that I did with this one.

DW: Now, why would these loving sphere beings that wanted you to be their delegate, why would they ask you to have to go in there and have a meeting with what would be the biological equivalent of the devil?

CG: It's part of the job.

DW: You had told me before that . . . Because I remember when this was happening, we were talking about this on Skype. You were originally going to go in and then the meeting got canceled. And I think it was the sphere beings that called it off?

CG: Yes. I was expected to be picked up. I was actually contacted and told this has been canceled. I was picked up and brought in the usual manner, with the blue sphere's beings, the little orbs.

DW: Could you just again briefly describe what happens?

CG: In my room, a blue little sphere, orb, comes into the room and zips around until I acknowledge it and let it know that I'm ready to be transported.

DW: So you get out of bed or get dressed?

CG: Get out of bed, get dressed, whatever needs-- for that occasion. And then it zips to about 18 inches from my chest, stops, and then in the twinkling of an eye, expands to where I am now inside of it and I am floating directly in the center of it. And then it shoots through the wall and off into space into one of the giant blue spheres where either one or three of the Blue Avians is waiting for me-- unless it takes me to another location, but in this instance that's where it took me.

And Raw-Tear-Eir explained to me and showed me holographic visualizations of these beings talking about ripping me apart and humiliating me by urinating on me and all these horrible things, and that they had called off the meeting. I was supposed to originally meet them, and I'm speaking a little bit faster because there's a lot of information to get in.

DW: Sure.

CG: I was originally supposed to meet them in a deep, deep underground cavern somewhere. So this was called off and renegotiated to where I was going to be meeting them on the surface of the planet, and I was allowed to have four Secret Space Program security personnel with me, who were also intuitive empaths. And so that is what occurred.

DW: Now, these Draco wouldn't have wanted a meeting, necessarily, prior to December 5, 2014?

CG: No.

DW: And what was it that happened on December 5, 2014 that was such a game changer?

CG: There was what we're calling an outer barrier erected by the sphere beings that encompasses the entire solar system, and it reaches out far beyond the heliosphere. It is pretty far out. And it keeps any beings from coming in and any from leaving. It is a quarantine.

DW: What about radio communications or those types of things?

CG: There's been a lot of confusion about that. These quantum correlated communication devices have worked that the Secret Space Program people have been able to contact the Galactic League of Nations program to try to talk with them, to try to negotiate allowing them back into the solar system. So I don't know what all other groups . . . If we have that type of communication technology, surely some of these more advanced groups do too. But radio communications and that kind of thing are not going to penetrate.

DW: What was the immediate action that the Secret Earth Government syndicates had taken that seemed to cause this barrier to go up as sort of like an instant karmic blast?

CG: Well, I don't know if this was a cause and effect, but the Secret Earth Government and its syndicates and the military and some extraterrestrials had developed a very powerful weapon that they aimed at a sphere. And I don't know if that can be put up right now, but--

DW: Yeah. Let's have the clip now. This is a shot from the International Space Station, December 5, 2014. What are you going to see is a little red spot and what looks like a laser beam. So what we're seeing there is a red sphere that looks about 1/4 or 1/5 the diameter of the moon in size with what looks like a red beam going up to it. So what were we seeing there?

CG: What occurred is there are three different sized spheres from the Sphere Alliance. One is the size of the moon, one is the size of Neptune, one is the size of Jupiter. This is one of the ones that was the size of the moon and was in fairly close to Earth.

DW: Now normally, we couldn't see it with a telescope.

CG: Right. It was . . .

DW: It was cloaked.

CG: . . . it was cloaked. But somehow through the extraterrestrial help, they were able to pinpoint it, target it, and fire this incredibly powerful weapon into space at the sphere. The Sphere Alliance use defensive type technology and what they did is they redirected the power from the beam back to the source.

So what witnesses said is they saw the sphere light up red and then a red beam come back down and hit the installation where the weapon was fired from. And the installation was destroyed with loss of life of humans and non-humans that were involved in this attack, the attempt.

DW: Do we know where this was?

CG: I was told that it was one of two locations in Africa or Australia, but I've since been told it's most likely in Australia.

DW: Well, Pine Gap in the middle of Australia, is a major facility. Do you think it might have been that?

CG: That's where I was told it was. It's likely in one of the-- not Pine Gap proper, but one of the . . . They have Pine Gap and kind of like you have Area 51 and S4. They have a lot of areas like that, but one of their weapons testing facilities close to there.

DW: So this must have been extremely demoralizing for the Cabal. Were they expecting to get a big light show and actually blow up the sphere? Is that what they were hoping to do?

CG: Yes.

DW: And instead they got instant karma spanking.

CG: Yes.

DW: So a lot of high level people died in this.

CG: Yes, very high level people from what they call the Cabal were present for this weapons test, and there were some extraterrestrials that were there, as well, that were here on Earth that were engineers that were helping develop this, that had a vested interest in this.

DW: How soon did this outer barrier go up after this happened?

CG: It was almost immediately.

DW: Well, I just have to point out how interesting it is with the Law of One material that they are always talking about how with their Prime Directive, or the law of free will, that they cannot take an offensive action. But if the negative tries to do something more negative, that that authorizes new actions to be taken. That sounds like exactly what happened here.

CG: I was told it was somewhat of an Aikido principle that was used, redirecting their energy back to them.

DW: So let's get right into it. You're saying there's tsunamis of energy coming into our solar system through the sun. You mentioned to me in a private conversation, and maybe on camera, that these Sphere Beings have used the word "major cycle," which again is also used in the Law of One. The source of the Law of One says, I am Ra.

When the people in that first meeting you had as a delegate asked these beings behind you, who are you, what did they say?

CG: Well, one of the people asked, "Are you the Ra from the Law of One?" And his answer just was one quick answer, "I am Raw-Tear-Eir."

DW: In the Law of One, they talk about the fourth density shift. They say somewhere around 30 years after 1981, but they're not specific, that we go through a quantum leap. Now, why would these extraterrestrials be so urgently wanting to get out of our solar system after this outer barrier goes up? What would happen to them if they don't get out? Are they expecting something to happen?

CG: Well, they apparently are going to be held to account for all of the negative things they've been doing here for many millennia. And when this barrier went up, they were trapped. And that's why Gonzales and myself were named as delegates to start going to these meetings.

DW: OK.

CG: And getting back to Gonzales, as soon as I got back from that week of doing videos here, I was contacted by Gonzales, and he told me, "I've had quite a time." He said, "I was brought to meet the Draco Alliance Federation, and I also sat in on one of the Super Federation conferences." And I was very surprised, but apparently he did a very good job.

He immediately told me he apologized because he thought that I had exaggerated the experience with the White Royal Draco and when interfacing with it, it was such an invasive . . . It was like microwaves penetrating my frontal lobe, and it grabbed ahold and held me there, held me in place when it communicated with me. It was very invasive. It was unlike any type of other communication. And when it did so, everything else I lost . . . I was no longer paying attention to anything else. And its eyes were constantly morphing and changing colors-- blue, red, all colors-- and its slit pupil was going wide to where its eyes were getting black. And then it was just very, very invasive. And in his situation, he had come in and this group, this Cabal, pretty much group or Secret Earth syndicate group called the Committee of 200 that we had dealt with before, had their leadership there, and they call themselves the chairmen.

DW: Well, I want to interrupt you because the viewer may not know, what was the demand of the white reptilian when you met it the first time? What was it asking you? What was it demanding?

CG: In my meeting, it started off with demands and then wanted me to bring proposals to the Sphere Beings. And its proposal was that they would give up all of their human followers, which are the Secret Earth Government and their syndicates, to the Secret Space Program Alliance. They would give up their lower caste reptilian soldiers and their ET allies that were trapped inside the solar system if the Sphere Being Alliance would allow the White Royals, Dracos, safe passage out of the solar system.

DW: So they were literally willing to betray everyone working for them-- their entire army, all levels of the hierarchy, everybody who was told they were gods on Earth, they're so special, they're the Illuminati, they're the white light of the Earth. And the Royals said, "We'll give you everybody, just let us go."

CG: That was the offer.

DW: Did this trickle down into the Cabal? Did they find out that this betrayal had occurred?

CG: Well, the representatives of the Committee of 200 were there and witnessed this betrayal.

DW: Well, you're saying Committee of 200, but everybody who's studied this, all the Alex Jones people, say, wait a minute, it's a Committee of 300. Did something happen? Have some of them defected? Do you think that's what it might be?

CG: I don't know where the difference comes in. I was introduced to them always as the Committee of 200.

DW: For how long?

CG: Going just-- back for the last several months.

DW: So it's possible that there could have been a defection of 1/3 third of their members.

CG: Could be.

DW: OK. So they're willing to give everybody up and then all of the Cabal people find out this was done.

CG: Yes.

DW: That must have been very upsetting to them.

CG: Yes. And this immediately caused a lot of splintering and infighting among all of these Cabal groups and syndicate groups.

DW: Undoubtedly.

CG: And they were turning on each other. This is also when a lot of these Cabal groups started to turn state's witness, I guess you would say. They would defect to the Secret Space Program Alliance and bring with them a treasure trove of evidence against the Secret Earth Government Alliance and give a promise to testify against them in future hearings if they were granted off-world sanctuary and an off-world witness protection program for them and their families.

So all this stuff occurred, and it'd been a big mess. So that kind was important to ask. That sets the scene for when Gonzales came.

DW: You and I were here working, so the Sphere Beings couldn't use you as their delegate because you were already busy.

CG: Right. And they considered this as important. So when Gonzales arrived and these chairmen from the Committee of 200 met them in a similar location above ground in the southwest US, he said that his jaw dropped. I'm not going to say the name, but it was a very prominent policy maker, well known for advising many presidents and supporting the New World Order and being behind depopulation efforts - an old guy with a thick accent, droopy eyes, and curly white hair.

DW: I think you've said enough.

CG: Yeah. He said his jaw dropped when this person came up and introduced himself, guided him down the hall, told him that he needed to be a little bit more respectful than in a previous incident, that Gonzales had made some major waves at. And he was walked in, and he said that him and the guards' intuitive empaths, felt everything was staged, everything was set up to be very theatrical from the very beginning.

DW: Theatrical for what purpose?

CG: To give the perception that the Draco were not dealing from weakness, that it was just theater, a show of strength.

DW: OK. What were some of the features of the site or the way that it was done that were intended to show strength?

CG: As they walked into the giant foyer of this shutdown hotel, there was what wasn't present previously, a giant, huge honor guard of soldier reptilians holding these long staffed weapons with blades at the end that looked almost like broadswords. And they were standing there with their feet about shoulder width apart, standing there kind of like at attention. And behind them were mantid beings and some other insectoid beings that were standing in some sort of loose formation. And then they were walked, and in the middle of this formation was standing this same White Reptilian Royal Draco.

DW: And this is basically the head of the whole Draco, the number one.

CG: So he claimed.

DW: OK.

CG: And he immediately grabbed a hold of Gonzales' mind, and Gonzales said it knocked him back on his heels.

DW: Wow.

CG: Gonzales said before that point, he was sure that I was exaggerating. And at this point, it-- in no uncertain terms it told him, "Repeat everything I'm saying so everyone can hear." It said that "Blue Avians in the Sphere Alliance have deceived you in how powerful we are and how powerful our overlords are." And I was sitting at the table with Gonzales at the time, and Gonzales said, "This is the first time that they had confirmed their overlords, that they reported to someone higher."

And he stated in no uncertain terms that none of the human followers were to be prosecuted, they were all to be given clemency, and that all of the ET groups and the Draco were to be allowed to leave the solar system at will and that if they didn't, they were going to begin to start reaping havoc on the surface of the Earth through war and strife. And he just went on and on and on--

DW: Like false flag, lone gunman-type stuff?

CG: Yeah, to build up loosh energy.

DW: So it's not like reptilian soldiers with broadswords are going to break loose on the surface of the Earth.

CG: No. It was using their human-- manipulating events on the surface of the Earth to reap havoc.

DW: But aren't they already doing that?

CG: Well, yes, but this was . . . They were talking about stepping it up in a major way. We're talking they were, like, threatening World War III and all kinds of stuff that we've already been assured by the Sphere Alliance is not going to be allowed to happen.

DW: Well, and it seems like benevolent beings such as the Sphere Alliance and maybe others helping them are making it impossible for them to do that.

CG: Yes. There's been so many attempts to start World War III that have been thwarted. We could talk about that later. But anyway, this--

DW: So now they're going to push much harder than they were before.

CG: They made this threat.

DW: Right.

CG: And he made all sorts of grandiose threats and then broke off contact with Gonzales and turned away. And then him and his whole delegation just marched out-- lumbered out of the room is the way Gonzales described it. And Gonzales had a huge headache. He was nauseated, all the symptoms I had afterwards, and he was just wanting to get the heck out of there.

And as they were leaving the way they came in, that same chairman person was walking them out, telling them how serious it was that they - more theater - he said how serious it was that they listen and take up the offer that this White Royal had offered. And they went back, went up to the roof, got in their vessel, and flew back to give the report.

DW: Sounds like the Draco actually gave away a very impressive secret, a very valuable weakness, that they have an extradimensional overlord that they answer to.

CG: Right. And this extradimensional overlord-- also Gonzales leaned forward. He said, "We believe this extradimensional overlord is also responsible for the ET/ED AI threat." He said there's a lot coming together right now that has been speculation, and intelligence has been leading towards for a long time, he said, but this was a very big confirmation.

And I asked if these reptilians, the Draco, if they were AI prophets. And he said, "Either that or they're working side by side."

DW: Does the Space Program Alliance have a plan to defeat the extradimensional overlords of the Draco? Is there a way to cleanse us of this AI? You mentioned the AI is seeing threats against itself in the future?

CG: Yes. To answer your question real quickly, and I cannot get into it, there is a plan to cleanse the Earth and the solar system of all AI signal.

DW: So we'll be completely free of this?

CG: Yes.

DW: And is this akin to the archetypal notion where if you yank the brain out from the central nexus, then all the drones just collapse over?

CG: All of AI will be taken out in this one move that like I said, I can't get into.

DW: Without that signal, what will happen to the beings that are loaded up with nanites?

CG: The nanites will just be dormant.

DW: So if those beings are feeding on the nanites, if there's some sort of symbiosis, it would be really bad for them.

CG: Yes. And this leads us into some other discussions about etheric beings that are also going to be driven back to what they call the outer realms and humans that have these entity attachments, that have symbiotic relationships with these entity attachments, and how they're going to suffer when these entities are driven back to these outer realms. We can talk about that another time.

DW: All right. Well, we ran a little over on this one but you probably didn't care because this is all very fascinating. I'm [David Wilcock](#). This is "[Cosmic Disclosure](#)" and we'll see you next time. Thanks for watching.

Cosmic Disclosure: Viewer Questions Part 2

Season 2, Episode 17

DW: All right. Welcome to another episode of "[Cosmic Disclosure](#)." I'm your host, [David Wilcock](#). We're here with **Corey Goode**. And we're taking your questions to bring this into a more interactive style of doing the show.

So as I've said before, we are reading the comments that you leave in the comments section. And we are starting to find things that people are asking that are worthy of inclusion. And hopefully, you're going to like these episodes.

It's a little bit different. Instead of focusing just on one topic, we're going to cover a grab bag of what you are asking us. And that, in turn, gets fed to **Corey**, for those people who are lucky enough to have their questions selected. And so in this episode, we're going to go through more of that very interesting

stuff.

So **Corey**, welcome back to the show.

CG: Thank you.

DW: All right. Obviously, you're a controversial figure. This was a question. I'm going to paraphrase a little bit from albacore. You got brought into this at a young age. And so first of all, let's just set the stage. You mentioned briefly before that you were in something in school called the Explorer program. So could you describe what that was, exactly?

CG: Back in the '70s and '80s, they would create programs for children that were gifted. They had programs for children that were special needs. They had all these different types of programs that were not the mainstream classes for children. And if you popped up in testing as being a child that would fit or be benefited in one of these programs, they would further test you, get permission from your parents, and then put you in one of these different programs.

DW: So was there a component to the Explorer program that took place in school? Were you brought into special classrooms and given--

CG: Yes. Yes. I was at school most of the time. It wasn't every day that I was leaving school. It would come in waves to where it'd be two or three days a week. And then, I would be in school.

DW: OK. Did the Explorer program involve you going to different classes than the other kids?

CG: I was in completely, completely different classes.

DW: All day long?

CG: Yes. Well, that was once I reached after elementary school.

DW: OK.

CG: During elementary school, I was in the same classes, but I was being brought out. I was in mostly the same classes. I would be brought out for certain different classes. And then, sometimes, during the whole day, me and other kids were taken out on "field trips."

DW: What were the things that happened in some of these classes that would have made them different from what other kids were doing, like the stuff where you're actually in school?

CG: Well, some of them would focus on, if it's for gifted kids, it would focus on a curriculum that was either a grade ahead of what they would be doing. It just depended on which program you're in. I ended up getting bounced around later on into different programs. At one point, they even had me-- and my friend John was like, what is going on? For one semester, they had me in a class with kids that were still wearing diapers.

DW: Developmentally disabled?

CG: Right. And I was sitting there. And they were giving me basically no work to do. And it was very bizarre.

DW: What could have possibly caused that to happen?

CG: I got moved into that class.

DW: Were you having post-traumatic stress from these things you were going through when you were taken away from school?

CG: No. I was testing reading comprehension. I was like four grades ahead. I was testing ahead. I had some behavioral problems. But I was getting in fights and that kind of stuff.

DW: But you said your nickname was Kicking Ass **Corey**.

CG: Yeah. That was my nickname. But there was no rhyme or reason for that semester of why I was in that class.

DW: Weird.

CG: And during that semester, I was brought off campus quite a bit. But I had a friend, John. We were in all the same-- most of the same-- classes the year before. And he was like, what are you doing in that class? I never see you. So it was bizarre.

DW: Did your parents know that you were being taken off campus?

CG: If they did know something was going on, I think that I don't think they could admit it to themselves. I've really asked some probing test questions. I really don't think they knew the full scope of what was going on.

DW: Well, OK. But let's dig in a little deeper to this. Do they have like a film that they play for your screen memory? If you're being brought out of school that much and they've got to keep putting screen memories in your mind, can they use the same tape? Or is there a lot of work that they have to do to actually generate screen memories for you? Do they show you movies? Do they just narrate something into your ear? Here's what you did in school today. This is what you're going to remember now? How does that work?

CG: So if you were supposedly going to the Museum of Natural History for the day, you would have a screen memory of going to the Museum of Natural History that day implanted. And for most of the kids, the memory would stay intact. The kids that were brought in that were more of the intuitive empath sliding scale were a little bit harder to do screen memories, some blank slating of memories on. And they had to be managed closer.

And they also had people-- there would be kids that didn't make it throughout the whole program that would wash out, that couldn't cut it in the program, so to speak. And they would be blank slated, and not picked up for the program anymore. A lot of them had a lot of abandonment issues that they didn't understand. They felt rejected. But in conscious life-- but didn't have a reason for it. And the groups kept an eye on them to make sure that they didn't have memories coming back.

DW: How did they actually put these screen memories in your mind? Are you shown a movie? Does somebody talk in your ear while you're under drug influence? Or what is it?

CG: Well, different ways. First of all, they would give you a shot of a synthetic scopolamine.

DW: Really?

CG: Yeah. And mixed with other designer drugs. And they had situations to where they would have a person sit there and hypnotically talk to you with their voice in a certain way.

DW: After you've been injected?

CG: After you've been injected. And then, they would debrief you at the same time that they were doing the blank slating and the screen memory.

DW: What does that mean? What is the debrief?

CG: Basically, what you did that day. There would be a debriefing. They would take notes or videotape it.

DW: And discussing what you actually did that day, where you would share with them--

CG: What you did, your training.

DW: Your experiences in the training.

CG: Right. Right. And then, they would go through the process of telling you, you will forget this, you will forget that. And they would put in trigger words or keywords that would lock or unlock the information.

And then, they would move on to the process to where they had different ways of doing it, to where they could show you a film, a video, with headphones on. They had shades that they could show you that had images on them. And some of the times, when kids were younger, they would read a book to them to try to give them a dream scenario. Read a book to them while showing them silent images on video. There were a whole lot of different ways of doing this.

And there was also the virtual reality component that they would use of once they had people in altered states, giving them a virtual reality type of overlay memory.

DW: Did they ever show you movies where the movie would have the data for your screen memory for that day in it?

CG: Yes.

DW: Would they make films for that purpose?

CG: Yes.

DW: Did the drugs they gave you somehow psychedelically enhance the movie as if it was real and not just a movie?

CG: Yes. Yeah. There's a very interesting documentary out that some guys did about scopolamine. I think they call it "The Devil's Flower," or something like that. I encourage people to take a look at that documentary. It's in its raw form. People lose control of their free will and will do whatever they are told.

DW: Isn't it true that you can blow it in somebody's face?

CG: I believe so. But usually, they give it to them in drinks or something.

DW: Right.

CG: And they become completely open to hypnotic suggestion.

DW: Yeah, I've seen the documentary. There's a woman who says, yeah, I'll let him come into my house. And I'll give him all my furniture and all my belongings happily. And smile as they're taking it away.

CG: And help them carry it out.

DW: Right.

CG: And they already had other synthetic drugs that they used that did similar things. And they created a synthetic scopolamine and made a cocktail. But scopolamine, synthetic scopolamine, was one of the things that was in it.

But they found that heavy use of it was causing psychotic breaks in some people. The chemical way of doing it was not very good for people. So they discovered a technological way of affecting people's chemical and magnetic memories in their brain without being chemically invasive.

DW: Next question comes from noahward. And the question is, do we have a timeline for the data dumps?

CG: I'm told that the data dumps are going to occur after a catalyzing event that's going to occur down here on the surface. This doesn't necessarily mean it's going to be this. But an example was given to me of something like a global economic meltdown, to where it became obvious to everybody on the surface, all of the sleeping masses, that it's been a giant Ponzi scheme. Everybody that they voted for and supported were criminals in these people's pockets. And the people, the masses of people that were normally asleep and wouldn't listen to things that people consider conspiracy theory, will now be open to the information.

After that point, the information will be dumped on the population through many different media sources, including the internet.

DW: One of the things I covered about the Alliance, the terrestrial Earth-based Alliance, was, of course, we had the Oklahoma City bombing. Very strange event. How did this one little van have enough explosive power to take off the whole front of the building? Doesn't make any sense. It seems like it was a trial run for 9/11.

What a lot of people don't realize is-- and you can go back and find articles on this-- two days before the Oklahoma City bombing, a whole airliner filled with flag officers, high-level military officials, crashed. And they all died.

CG: I remember that.

DW: And Sherman Skolnick had data saying that those people were ready to go to Washington with absolute evidence that POWs who were known to still be alive and still be tortured in Vietnam, that that had all been covered up because they had compromising information about the government, and that they had with them a guy who was supposed to be dead, who had been written off as dead, who'd been a POW this whole time, and had this information that they were going to formally present charges of treason to the president at the time-- was **William** Jefferson Clinton. And, of course, they got ached. So I think-- have you heard of that event on your own?

CG: Oh, yeah.

DW: Oh, you did.

CG: Yeah.

DW: OK. So do you have anything more to it than what I just said?

CG: No. But that's one that's known. There have been several attempts to thwart the powers that be. And somehow, something like that always happens. Some sort of a freak plane crash, heart attack, illness. They always seem to be one step ahead and know that it's coming.

DW: If you had the answer to the timeline question for the data dumps, doesn't that in and of itself compromise operational security? If we knew how it was going to happen, if we knew when it was going to happen, and if you actually had that information, you couldn't say it, because then the Cabal is going to make a defensive move against it, somehow.

CG: Right. And I doubt very seriously they would give it to me.

DW: You said that you found out from Gonzales that they are withholding a great deal from you about the moves of the Alliance and the plans of the Alliance because you are now out here in the public sharing what's going on.

CG: Right.

DW: So it's possible that there could be a plan that is far more specific and detailed that you and I just have no access to, and that maybe the things that we are told might even be deliberate diversions so that the Cabal will not anticipate how this is actually going to go down.

CG: Right. And the Cabal has been using this advanced artificial intelligence technology that gives them probable future scenarios that help them stay one step ahead this whole time. They've found a way around this. And they are pretty confident that they'll be able to do the data dumps if the Alliance on the ground cooperates.

DW: Well, I'd also just point out, as one other thing for this question, go and watch my "Wisdom Teachings" episode where I'm talking about openly announced in "Pravda," the Russian media, that Putin has got video footage, audio footage, solid evidence of the Bush administration being behind 9/11 using mini nukes. They've tracked the nukes. And that they're going to drop that data at the right time. And that was openly announced by the Russian media. So that could be another example. Some kind of big thing about 9/11 could kick it over the edge. There's lots of things that could kick it over the edge, potentially.

CG: Right. But if the data dump happens too soon, the Cabal will be able to mitigate it, call it conspiracy theory, tear it apart, and take it down.

DW: And you said that some of the people in the Earth-based Alliance have now treasonously told the Cabal what's in the data dump.

CG: Shown them.

DW: Which gives them the opportunity to prepare alibis and counterarguments for it.

CG: Right. And it's also made them want to create a World War III scenario. That kind of stuff.

DW: I don't really know how much you can do with this one. But let's give it a shot. It's from KD. And it's a very short, simple question. How many parallel worlds are there?

CG: I know of only one that I read about. But it would stand to reason that there are an infinite, infinite number.

DW: OK.

CG: I seem to remember that there was something about them going in-- there's a parallel reality. And then another parallel reality this way. And they go in a circle, or in a certain way. That there are many. But just travelling between. We're just travelling between this one that I've discussed where they use the Xerox room that sends people through this unpleasant type of portal.

DW: OK. So let's go back to what you know personally about this.

A parallel world could be something that happens in the guise of time travel. So let's say you go back to the Earth. You reverse back in time. But you're here on the Earth. Are there two copies of you now that exist? Have you cloned yourself? How does that work?

CG: Well, being that time is basically an illusion, and time is all happening at the same time, it only appears to be linear to us with our consciousness. Consciousness, to answer your question, when you travel in time, you're creating a new timeline. But this timeline that you're on is something that you're creating with your consciousness. And if you do something to affect that timeline and then travel to the future, your consciousness is going to affect--

Let's say if you kill your great-grandfather, and you travel back to the future and expect to have your whole family lineage dead, may not necessarily be so. That may have occurred on a different parallel timeline. And for a massive change to happen, a whole lot of people have to have a mass consciousness shift and perception of the change of time.

DW: Could you go and see yourself? Could you go and find **Corey** as a 10-year-old boy, and then be standing there and look into your own eyes? Is that theoretically possible?

CG: Theoretically, speculatively, yes. It's possible.

DW: Would that somehow create a time paradox, where if you've seen yourself, then you know that you exist in the future, and that alters your future somehow?

CG: Maybe on one timeline or parallel reality. But not necessarily on the timeline. When you go back, it's not necessarily going to affect your native timeline.

DW: Right. So I think the key would be that we're so badly wanting to have one thread of time, one linear narrative that stays consistent, so that if you change the past, that everything changes. But it's really just like the timeline exists where you are here. And you go forward. But then, this one also

exists where you go backward. And now, you're layering another one on top. And now, the two are sandwiched.

CG: Right.

DW: So what would happen if you tried to do this too much? If people were time-travelling back, wouldn't it cause a lot of big problems? You mentioned that there were buffers on the spaceships that you guys had to prevent this time travel. Why were they so concerned about time travel?

CG: Yeah. Temporal technology, like temporal drives and that kind of thing. They didn't want people accidentally popping into different timelines and that kind of thing. Or purposely.

DW: What are the problems that it causes if they do that?

CG: You can use your imagination. If one of the newer craft popped into the older timeline and stayed there, that craft could alter that parallel timeline's outcome by giving them a new technology that's far ahead of what they would have had.

But I was also told that timelines, people were going back trying to correct timelines by going back before they screwed up, perceived that they screwed up a timeline. And they were going back and back and back trying to fix timelines. And we were finally told by another race to stop screwing around with it, that time is more elastic than we realized, and that things snap back and go the way that they're supposed to, according to the co-creative of mass consciousness of the root timeline that you're from. And there is a component that I've been briefed on a little bit that does go on with a time travel component that is not really supposed to be talked about that is going on with a certain group. I guess you wouldn't really call them time lords kind of a thing. But there is a group that does skip around in time and keeps an eye on other groups that have temporal technology.

DW: Interesting. So we have one from C-U-K-O-S. And it is, how did the Voyager space probe cross the edge of the heliosphere if there is a barrier?

CG: There was not a barrier up there during the time that it crossed.

DW: When did the barrier form? And what caused that to happen-- just to review, even though we've mentioned it before.

CG: Right. That occurred, I believe, in December of this past year.

DW: 2014.

CG: 2014. And it was more than likely scheduled to happen anyway. But it occurred right after the Cabal groups had fired an energy weapon at one of the spheres that was in far Earth orbit. It lit up the sphere with an aikido principle redirected their energy back at them and destroyed the base. And things seemed to escalate very quickly after that happened.

DW: Sure. Is there a protocol of meditation that people could follow that would help them contact extraterrestrials?

CG: Anyone can reach out with their mind. There are any number of ways to meditate, like we've talked before. Even daydreaming, prayer, meditation, all the different types of meditation themselves are getting your mind into that state. And when you broadcast your consciousness out, anyone can do it. But should you be doing it is the question that they should be asking.

There are a lot of different beings that are sitting there waiting for people to reach out with their minds to make contact with them. And most of them are deceptive. They have the ability to make you feel totally blissed out, to make you feel love, make you feel love and light. They can manipulate your body to feel all kinds of things. And they can download all kinds of complicated, interesting information that is not necessarily accurate.

DW: Well, Jacob, the other Space Program insider, told me that there was a particular extraterrestrial group from Alpha Centauri that they were calling the Centaurians, and that some kind of treaty had taken place where these Centaurians-- who look, essentially, like people from Spain, but albino. And they're very ripped, with light-colored hair and very pale skin-- were being allowed to start to mingle into our society. But he told me that if a Centaurian knew that you recognized that they were an extraterrestrial, that it was very dangerous because they could then track you telepathically. And that could end up being very bad for you.

CG: All these groups can track you telepathically. A lot of these people that are taking these little courses online, and saying, I'm a remote viewer now, and try to remote view different bases and areas, they have people that are remote influencers, that have technology enhancing them, working as groups, that protect those places. And they can track you right back to your home. Right back to your bed. And they can cause a lot of problems for you.

DW: Are there Cabal honey traps online, where they try to find people who are starting to wake up and lure them into something?

CG: Yes.

DW: How does that work?

CG: Some of the places where you go to take personality tests, they trick you into taking tests that will tell more about yourself. Some of these dating sites that ask a whole lot of questions about you. They're all profiling you. Even some of these sites where you're doing a study on your heritage information--

DW: Or the alleged IQ test.

CG: Yeah. And all these types of tests. There are a whole lot of different little honey pot traps that they have. And then, of course, they look for people's internet traffic.

DW: Will they be trolling forums like "Above Top Secret" and "UFO," that kind of stuff, looking for people there?

CG: Oh, absolutely. And we'll talk at some point and length about how when I was working I helped set up a data center with virtualized computers set up all over the world, where people would sit at desks with six monitors and pretend to be like a dozen different people going into forums and different sites arguing with themselves with IP addresses from different parts of the world, stirring up problems, finding people that were putting out information they didn't like, and attacking them and discrediting them. And that kind of thing.

DW: Let's end this on a positive note. Do you believe that we have a higher self?

CG: Yes.

DW: What about contacting the higher self? What would be an appropriate way to start seeking spiritual information?

CG: First, you've got to turn inward. Start looking inward. You start working higher and higher up. When you start working, you start meditating more, looking inward more at the bad things about yourself. You start trying to not only forgive yourself for those things and change them, forgive others. There's energy that's released. And you begin to expand. And you begin to work higher and higher and

higher up the higher self, until self falls out of the equation, and you just reach higher. And that's how you eventually, I believe, reach back to what people call source.

DW: Very cool.

Well, that's all the time we have for this episode. So we'll see you in future episodes of "[Cosmic Disclosure](#)." I'm your host, [David Wilcock](#). And I thank you for watching.

Cosmic Disclosure: Introduction To Inner Earth

Season 3, Episode 1

DW: Hello. Welcome to [Cosmic Disclosure](#). I'm your host, [David Wilcock](#), and we're here with **Corey Goode**, and in this episode we're going to get into a very interesting subject, something we have not covered before, the Inner Earth. And this is a really unusual area. So **Corey**, welcome to the show.

CG: Thank you.

DW: Let's just get this out of the way first, so nobody starts hurling brickbats at us. You are not saying that the Earth is hollow on the inside, and that there's the sun in the middle. Nothing like that.

CG: Correct. It-- instead of a hollow earth, we would call it more of a honeycomb earth. A large network of porous caverns that range larger than the size of Texas. Huge, huge caverns that run all the way, you know, to about 40 miles below the surface, the crust, where it goes down to the mantle.

DW: Now, when I spoke with the Space Program insider, who I can call Jacob, about this, who worked directly with the Rothschilds, he said that it is a basic part of physics as a planet forms, and in the rotation, as it starts to cool, he said that the outside cools first.

And then the forces of centrifugal force kind of throw the material against the edge, and you get these bubbles that form, because the edge is solid, and then some of the material is bouncing off of that, and it creates this sort of cavern. And he was saying that you could have caverns that are anywhere between 20 to 40 miles deep inside the actual cavern. So did you hear anything like that about the actual geophysics of how these cavities are formed?

CG: Yes. Pretty close, pretty close, and the caverns are much bigger than that.

DW: Really?

CG: Yeah.

DW: So what did you hear about how they were formed?

CG: That pretty much-- it had to do with the centrifugal motion, certain elements, and certain types of rocks as they formed. Certain types of stone were heavier and lighter than each other, and so they started to move towards the outside, and then there is a somewhat viscous, or molten layer between the crust and the main mantle. And that the mantle itself is full of water, and there's tons more water on Earth than we know of.

DW: Well, and we've been talking about this, you and I have been talking about this since last October, I've been talking about it with other insiders for a long time, and I was stunned to see mainstream scientific papers saying that they now think there's twice as much ocean water below the crust than all the oceans that we see above the crust. Twice as much.

So this is a very unusual subject to try to get people talking about. Some of that ocean water, that twice as much ocean water is forming oceans inside these cavities in the Earth?

CG: Yes. There's-- some of it is small amounts of water that is built up into porous rock, and some of it is open areas of large, closed in oceans, and some areas are like rivers where the water flows through the mantle.

DW: Nobody would argue, especially with Earth, that where you're going to have water, you're also going to have the presence of life, at the very least microbial life. So I guess one of the really bizarre sort of learning curves to bring people through on this subject is we're not just talking about a big, empty rock chasm inside the Earth. What do we actually see if you were to be able to get into one of these? What do you actually see?

CG: Up until recently, the only information I had was what was presented to me on one of the smart glass pads. And there were many expeditions down to this porous earth, or honeycomb earth area, and these people were looking for ancient artifacts. That's what they were mainly looking for. They could care less about a lot of the other stuff they were finding.

But they documented it as a part of the expedition. They were finding all types of microbial life. Some of it were kind of like lichen that grow on rocks, that absorb and eat stone, but release light and provided-- and this stuff grew thick, almost like mats of algae. Like a bacterial algae that would grow on the stone. And it provided--

DW: So is it enough that you can actually see?

CG: It provided a low, luminescent-- a certain spectrum of the full spectrum that we're used to seeing.

DW: Wow.

CG: There were certain types of plant life that were able to, I guess, photosynthesize this light. There were--

DW: Were they unusual plants, from our perspective?

CG: Yes. They were different types. This is a totally different type of ecosystem that developed completely independent of the surface. You know, like-- some of them-- similar ones have been found close to the surface. I saw, you know, giant newts that are completely albino. You know, weird-- just a bunch of strange animal life.

DW: Like, mammal life with fur? That kind of stuff?

CG: Some spiders, some different types of insects.

DW: So did you see spiders that would be kind of gigantic compared to what we see on the surface? Anything strange like that with the insects?

CG: Right. A lot of them didn't have the pigment that they did on the surface. Some of the things that are large on the surface are smaller below. Some of the things that you would expect to be smaller were larger. There was kind of a-- I don't know how to describe it. It was kind of backwards a little bit.

DW: So there was a lot of whitish creatures?

CG: White, or just light pigment. Not a bright-- not a wide spectrum of colors, like you would see on the surface, since we have a broad spectrum of light to reflect off of them.

DW: What about, like, lobsters, shrimp, crabs, crustaceans?

CG: There were several different types of crustacean things down there.

DW: Shellfish?

CG: Yeah. More like shellfish.

DW: And I'm sure you had lots of regular fish, like fish you'd see in the rest of the ocean, or similar?

CG: Yeah. Lots of different fish that didn't have eyes. But, uh, yeah. There was a bunch of different type of fish that were documented that were rather small.

DW: Any bats or flying creatures? Birds?

CG: I don't recall seeing flying-- anything flying in there. And the plant life was small. It was obviously not only living off of the rock, in the minerals in the rock, but also the very dim light that was being put off by this weird lichen, or bacteria that was growing in a thick mat all along the inside of the cavern that was eating the rock.

And as a byproduct of eating the rock, it was converting, somehow converting some of the minerals, or energy into light. It was giving off luminescence.

DW: So we're not going to see a forest with, like, evergreen trees inside the Earth. This is a totally different biosphere?

CG: Now, this is what was shown to me. I don't know. There could be other ecosystems in different areas that have more of this, so I'm not going to say--

DW: Right. Like a terraforming.

CG: Yeah. I'm not going to say that that doesn't exist, but in the expedition files and information that I saw when they were looking for Ancient Builder race technology, back when they were trading it off-world for things, they were finding a lot of the this type of stuff that I'm describing. And this is what was being documented in their expedition files.

DW: When we see these plants that you said were down there, are they green, are they kind of an orange or pale color? What are we looking at, as far as the plants?

CG: They were a different-- they were not green, they were photosynthesizing through-- they were different color. Some of them were luminescent as well. Some of the plants.

DW: What do you mean by luminescent? Like, they glowed?

CG: They glowed. They gave off light.

DW: Really?

CG: There were a lot of real small-- looked like fern-like plants that I saw in photographs. But they were typically small, and they were either small, singular plants, or they looked like they were part of a larger colony, a plant that was of a colony of some sort. Like a root system colony plant.

DW: Did you have mushrooms down there?

CG: Yeah. There was all different types of fungus, and--

DW: Did they do any work to try to see if these plants appeared in fossil form in previous civilizations on the surface of the Earth?

CG: That was not in the report. That was not their interest. They were basically documenting their expedition towards their goal of locating certain ruins and technology that was below the surface.

DW: If a human being of our size is walking through, and you say these plants are small-- so we're not dealing with trees that would be taller than we are?

CG: No. They weren't walking through with machetes, hacking their way through.

DW: So most of this is what, like, waist high or smaller?

CG: Yeah, below the knee.

DW: Below the knee?

CG: Yeah. Most of it.

DW: And then otherwise, it's just a big, open space with this glowing stuff on the rock?

CG: Right. The plant life was spread out. Spread out everywhere.

DW: So it would fill out the whole area.

CG: Right. And I'm not a botanist, I don't know what exactly is classified as a plant, or what things are classified as, so I don't know what these would be classified as. But they looked in the photographs like plants, and they were described as a type of plant life.

DW: Was there anything living down there that was dangerous to us, predatory creatures that would attack us and potentially kill us, or try to eat us?

CG: Yes. They had to be very careful. There was a small lizard type of creature that was-- it was not technologically advanced, but they were very intelligent.

DW: You're saying not a lizard that walks on four legs, but a human looking creature?

CG: They walked on two legs and four legs. They're very dangerous, they hunted in small packs, and they showed signs of being intelligent, as in not even-- they were compared to like, cave men intelligence.

DW: Mm.

CG: You know, lower intelligence kind of beings that existed down there. And they--

DW: But they had a human-like reptilian face?

CG: Well, they were like a type of lizard of some type. And in the documentation--

DW: But you said they could walk on two legs.

CG: Yeah. They could walk on two legs and four legs, depending on, you know, where they were going through all the caverns.

DW: I guess I'm not really understanding, then. Is it something like a Grey, but like a reptilian Grey? Or is it much more like a lizard than a grey, in terms of the way it looks?

CG: It's much more like a lizard.

DW: OK.

CG: It's not like any type of space being.

DW: OK. So the face might not look human-like at all?

CG: No.

DW: It's a reptile.

CG: It's an animal.

DW: OK.

CG: Yeah. And supposedly there was documentation of, I believe, a long time ago, the Mormons were digging deep caverns to-- they were doing some sort of program where they were digging deep caverns, and they ran into some of these.

DW: What's the color on them?

CG: They're, like, a leathery kind of color.

DW: Like a brown?

CG: Like a grayish brown, but brown's not really the right color. But then again, this is taken under a different light. So if they were taken out and shown under a full spectrum light, they're probably going to appear different. You know, like, they have stripes on them in different areas, I think I remember them being described as.

DW: But they're more intelligent than any lizards on the surface of the Earth.

CG: Yes.

DW: Because you said they're like cavemen.

CG: Yes. They, like, use rudimentary kind of tools.

DW: Really?

CG: And that kind of thing. So they're very highly intelligent, but they were animals.

DW: So, that's one of the types of being that you said was down there. Prior to what we're going to get into in later episodes with your invited trip, you had mentioned other species that you saw that were down there.

CG: I didn't actually see them.

DW: Well, you saw evidence of them on the smart glass panel.

CG: Right.

DW: You mentioned to me in private conversation that one of these was bald, and had kind of large eyes.

CG: And a large kind of head, and pretty humanoid looking. They had real sparse kind of hair. It kind of stuck up. Not a whole lot of hair. And they were pretty much albino-ish. A little bit larger eyes, I guess, that it developed for the low light. These were groups going down with weapons, and scientists going down on expeditions to recover information.

They would run across certain groups, and out of an abundance of caution they would engage them, and then photograph and document their remains, and then move on in their expedition. So they weren't doing a big, you know, exchange program with these groups and studying them, and they seemed to know that they were-- some of them were dangerous.

They were of a lower caste system than our civilization, and they obviously didn't respect their life, their lives very much. And they were on a mission.



Artist impression of the albino humanoid based on **Corey Goode's** description

DW: Going back to the caveman reptile types, were these beings fairly common in various pockets inside the Earth?

CG: In different regions, at a certain region and at a certain depth, I seem to remember they were fairly common, and for the most part they kept their distance. But they would attack targets of opportunity-- humans, and there were incidents. So they were-- on site they would engage them and kill them.

DW: Were there any names or classifications for these different beings?

CG: I'm not a scientist. They would give what they're most likely related to in a Latin term of what they're most closely related to, and then they had information about it. But that's just information I can't recall.

DW: OK. So far we had the primitive caveman reptilian type, we had the bald headed type, and you mentioned the raptors. So let's cover those again, briefly.

CG: Yes. The raptors were this group that supposedly are remnants of the dinosaurs, that have been here since before humans. It was kind of described as a proto warm blooded-- like, they're mostly warm blooded. They're closer to birds than they are reptilians, but they kind of look kind of like both. They look kind of dinosaur-ish, but they have these weird, scaly feathers. Especially the-- all of them have, like, some sort of sparsely scaled feathers, like a plume down their neck. But the--

DW: The feathers have scales?

CG: They're not like soft, plummy feathers that you would think of. It looks like an early-- maybe a prehistoric feather. And these are higher intellectual beings. They have plumes of different colors that I was told are more pronounced-- their plumes are. And they move around, they're real jerky, kind of like birds, you know? They kind of jerk around when they move, and they are very quick, very dangerous, and are carnivorous.

DW: So, how ugly are we talking if we see the face? Like, for us?

CG: You would be terrified.

DW: Do they have vertical slit pupils, reptilian looking eyes?

CG: They were more of the bird eye.

DW: OK.

CG: More like bird eyes, like the perfectly round.

DW: But scales on the skin?

CG: It doesn't look like reptilian skin, but people see them, and they assume that-- the reptiles. And they look like they're some sort of divergence or mixture together of bird and reptile.

DW: Now, a bird doesn't really get facial expressions, for the most part. I mean, some parakeets or whatever, they can kind of do the thing with their eyes, but do these beings have facial expressions? So their faces are just kind of locked?

CG: Yeah.

DW: Do they have a beak-like proboscis, or something? Do they have a mouth that kind of protrudes, like a beak?

CG: Well, they've got the needle sharp teeth, like, similar to the reptilians, but I mean, there's not an actual beak. The raptors, like, if you Google and look at raptors, they look very much like that.

DW: So it has an extended snout, like a dinosaur?

CG: Yeah, it's kind of dinosaurish.

DW: Wow.

CG: Kind of like a mixture between a reptile, and kind of birdish.

DW: So it is almost like a dinosaur head stuck on a human form?

CG: Oh, no. Not a human form. Its arms are not real long, and its legs--

DW: Oh, like the T. rex?

CG: Not quite like that, but the legs are longer than the arms. They're real fast. I really don't know that much about them, other than the brief descriptions that were--

DW: Did their legs look more muscular than ours? Do they have a lot of meat on them?

CG: Yes. And they stay kind of hunched over a lot.

DW: So does their body almost look like a kangaroo?

CG: Kind of like a-- kind of like a dinosaur.



Artist impression of a Raptor based on **Corey Goode's** description

DW: If you get into the so-called Ancient Astronaut research, you hear about various cultures describing gods that said they were plumed serpents.

CG: Feathered serpents.

DW: Feathered serpent. Yeah. Do you think any of these beings ever came to the surface, and maybe wanted to be worshiped, or wanted to try to take on leadership roles for periods of time?

CG: It could be these, or it could be different ancient groups calling actual reptilians, feathered serpents, just because they flew, and feathers are associated with flight. I don't know. I don't have any direct knowledge. I really don't have a whole lot of information on that group, other than what I've read. I have not interacted with them, and I don't wish to.

DW: Sure. Do all of the caverns underground, or the majority of them have crystal looking pyramids and obelisks, and weird buildings built by the Ancient Builder race? Is that something you see almost everywhere, or is it only in certain ones?

CG: The deeper you go, the more you're going to find that kind of stuff.

DW: Oh.

CG: There are a lot of ruins-- like, strange, Pueblo kind of building ruins up against, like, some walls of caverns, to where it looked like at one time maybe tens of thousands of people of some sort had lived down there in ruins. They found pottery, they found all kinds of signs of more primitive life, of people that had maybe taken refuge down below.

DW: Right.

CG: The stuff you're talking about is the stuff they were looking for, and they had to venture pretty deep to get it. A lot of it had been picked over and taken by different groups, traded off, but there is still very little of this honeycomb earth that has been explored.

And post disclosure, when everybody, you know, there's going to be a whole bunch of new type of careers for people, and there's going to be, you know, spelunkers that are archaeological spelunkers, that are going to have so much here on Earth to explore and study. And there's a lot of stuff from the Ancient Builder race down there, and other groups that have--

There's been different ET refugee races, there's been ancient breakaway civilizations that have lived in different areas and moved on, and there's a lot under the ground that we've purposely been kept unaware of.

DW: It seemed like when I talked to you about this before you got invited into the Inner Earth, which is coming up in later episodes, that we had kind of sussed out six types of beings that you'd been aware of at that time, that were under there. So we had the primitive reptilians, we had the raptors, we had the bald headed folks. Do you remember any of the other three? Was there another reptilian type that you were aware of, like a reptoid?

CG: There's a reptoid that was an ET group that was-- they encountered below ground.

DW: And what are they like?

CG: The ones that were described were black, tall-- very tall. Not as huge and muscular. Skinnier, with their heads-- they didn't have the big jaws and teeth. They were more narrow jawed. And there was a--

DW: When you say very tall, you're like, saying 9 feet, or 11 feet, or 14 feet? What's the range?

CG: Not quite. I mean, very tall as in, like, 8 feet.

DW: OK.



Artist impression of a Reptoid based on **Corey Goode's** description

CG: You know? And there was a group that-- well, I guess we were watching "[Jupiter Ascending](#)" together that I was like, whoa, because it showed this elephant looking guy.

DW: He was piloting a ship.

CG: Yeah.

DW: And I sat next to you in the theater, the movie had just come out.

CG: Yeah.

DW: And your whole body, you went-- like this. I was like, dude, what's going on?

CG: Yeah.

DW: And then you told me that you were familiar with something similar to that. Not exactly the same, but similar to that.

CG: Yeah. And we did a little bit of digging, and there's some guy that has a whole story about a group that he encountered, that either he named, or they call themselves the Dero, that he depicted fairly accurately, that look like they have the elephant ears, and kind of the nose that kind of droops down.



Artist impression of the Dero

DW: It's almost like a trunk on an elephant.

CG: Almost like a trunk.

DW: A miniature trunk.

CG: Yeah. But it was-- it's really more like one of those-- it looks really more like one of those things on a-- what are those things that are kind of like sea lions? You know, they have those--

DW: Right.

CG: Things that hang on their-- it's more like that. But I was shocked to see that on the internet, and--

DW: Well, and this all traces back to material that came out in the early 1940s, called "The Shaver Mysteries," of a guy who claims to have been taken inside the Earth, and there was a negative group called the Dero, which is what this guy that we found the videos on was describing. And there was a positive group calling themselves the Tero, T-E-R-O, saying they were opposing them.

It independently said that there was very ancient technology inside the Earth that looked like it was made out of stone that they were looking for. Completely validated what you said, even though you'd never heard about this. And these Tero people seemed to be very spiritual, and they were trying to stop

the Dero from coming after us.

So this guy who did these videos was describing these people with these grotesque faces that looked like they had gills on the side of the nose, like a bluish gill, or something. Is that consistent with what you saw?

CG: A slit, yeah. A blue slit.

DW: Now, what it said in "The Shaver Mysteries," what this guy who claims to have been brought inside the Earth said was that these beings that have these grotesque features originally looked a lot more like us, but that they were negative, and they had come to the Earth to colonize the Earth, they tried to stay here, and there were some kind of energetics that changed their biology, and they realized they were mutating.

Many of them left, but then some of them decided to stay, but in the process of them staying, these energies mutated them into these monstrosities. Did you hear anything like that?

CG: All I knew is that what was described is that they were very nasty, were technological, could put up a good fight back, were very technically clever, and they were avoided. They were not a good group to-- you didn't want to end up in the middle of their territory at the wrong time. Wherever their territory was.

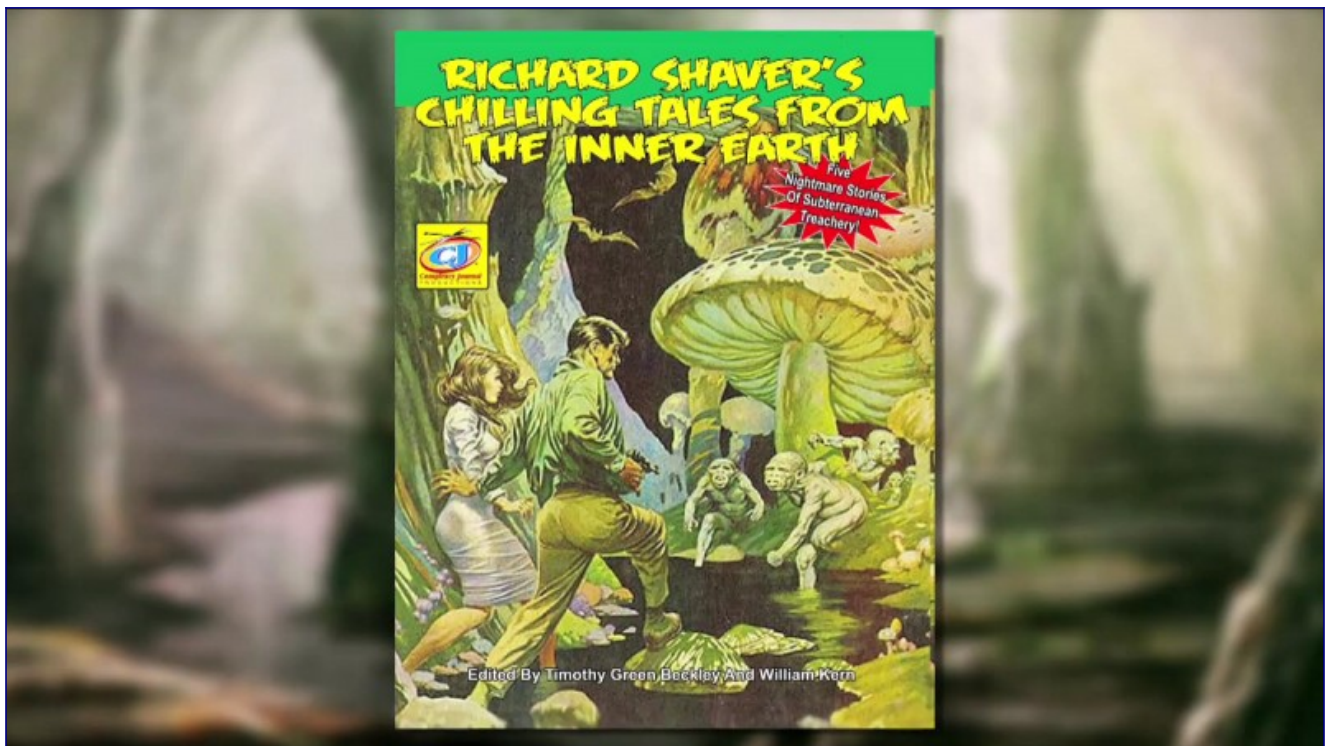

Cover art of *Richard Shaver's Chilling Tales From The Inner Earth*

DW: Do you think that these are the groups that are responsible for what **David** Paulides has been saying is happening in the national parks, where people are being abducted?

CG: There are a number of groups that are a part of that, including human groups that are taking people. But they very well, very well could be.

DW: Do you think that some of the national parks were deliberately built where they were because these were dangerous spots, where some of these Inner Earth civilizations that were negative lived?

CG: Let's just say they were made natural reserves because of what they knew was below.

DW: Right. Now, there are people-- there's a variety of reports about reptilian areas under the surface of the Earth in America, including apparently underneath Los Angeles, there was a big one. Do you know anything about that?

CG: Yes there were a lot of reports about close to the surface, very close to the surface, different reptilian layers, or places where small groups lived, where they would venture out to the surface from time to time, usually in arid areas. And there were reports that were investigated by groups on Earth, where people would see reptilians in the desert, and they would go and close off areas where they were coming out.

DW: **David** Paulides' research also described that people were more apt to be abducted if they had bright colors, or if there was a dog with them. The dog maybe is creating a lot of movement, and the color maybe can be seen on things that they have underground, that are monitoring the area for human activity. Would you recommend that people go to these national parks, or would you say that people should avoid them at all costs?

CG: I don't know. There's a lot of beauty to be had in these places, and I wouldn't want people to succumb to fear and miss out on a lot of beauty, especially sharing a beautiful time with their families. But, you know, you've got to be careful wherever you go.

I haven't taken my family to a lot of these places, just because I have known a little bit of information about what has happened around them.

DW: Fair enough. All right, well, we've now set the groundwork for the Inner Earth, and coming up in the next episode we're going to get into what you learned since all that, which is a very fascinating-- in fact, you said this has changed your life more than any of the other experiences you've had so far.

CG: It's been on my mind constantly since it's happened, yes.

DW: So we'll see you next time here on [Cosmic Disclosure](#). Thanks for watching.

Cosmic Disclosure: A Goode Trip to the Inner Earth

Season 3, Episode 2

DW: Welcome to "[Cosmic Disclosure](#)." I'm your host, [David Wilcock](#). And we are here with **Corey Goode**. And this episode is something that we'll be documenting, the beginning stage of what you said was probably the most life changing experience that's happened to you yet in this whole saga.

CG: Most mind expanding for sure.

DW: So I was going back over my notes. You started talking to me in October 2014, and then they asked for you-- the Sphere Beings asked for you sometime in February. And it was March 1st that I was taking down the reports of your initial meeting in front of the Space Program Alliance. So this didn't take very long. After you came out with your name, and started to reveal your real identity, it was only about a month before you got pulled into this really bizarre world.

CG: Yes.

DW: Now, we went through this Mars colony inspection already.

CG: Right.

DW: And that was quite a heavy experience for you because you basically end up getting arrested, and looks like, when you're put in this prison cell, that they might have been intending to terminate you.

CG: It wasn't good. Their plans were not good.

DW: It's not like you necessarily are looking forward to these trips off planet. Correct?

CG: Not only that. It has been the standard operating procedure for them to give me very little, if any preparation, intelligence, or information beforehand. A lot of times, I've been told you're going to be meeting with this group in this time window, and that's it. And I have very little. I go in blind, except for some of the situations when I've had some of the security support teams go in with me. They have more information than I do.

DW: And you've had to go through very difficult surgeries. You've got new scars on your arms that weren't here when we are taping last time. And they're not offering you any help, right?

CG: No, no. I've had a very contentious relationship with the Secret Space Program Alliance Council. They've pretty much told me from the beginning that I was forced upon them. They felt that Lieutenant Colonel Gonzales was the right person for the job to be the liaison between the Sphere Being Alliance and them, and these other groups as a delegate for these different meetings. They didn't see what I had to bring to the table.

I honestly didn't either, but they have given me a lot of pushback. I'd asked for access to technology at the LOC that I knew was just, depending on where it was, a floor or two below me that was technology that would have helped me. And I was turned down. And that bothered me quite a bit. And I wasn't getting any type of material support down here like Gonzales gets.

He gets material support for his cover life down here. And they've pretty much said you don't work for us.

DW: In your Inner Earth paper, you mentioned yelling and aggressiveness that took place between you and them. Were there other issues besides what we've already discussed that were going on?

CG: Yeah, there is one that I've decided not to go deeply into, something that happened with my family.

DW: Lack of adequate protection?

CG: Lack of adequate protection of me and my family, mainly my family, that was promised. There was an incident that happened. My children were involved. I was very upset. Things got very heated, and soon after that in a meeting-- and some of them became very agitated, and pretty much straight up told me they didn't like me. They didn't want me, that Gonzales was doing a better job than I was.

He was a better diplomat, better public speaker. He was just all across better, and that they didn't want me involved, that I had angered some of the Super Federation Council members by divulging information about them that they didn't want divulged, even though I was never told not to give this information.

DW: Right.

CG: It still upset them somehow. So things got very, very heated between us. There was there was a major falling out. I noticed I started getting less and less intelligence there for a while. And Gonzales was going to a lot of these meetings in my place for a short period of time.

DW: Well, and there was also some major obstacle just in your own life. I think you had a surgery, or there was a sickness, or something was going on. You really weren't in a position for a while where you could have gone anywhere.

CG: I had recently had a surgery, and that had something to do with it, but mainly they were trying to prove the point that Gonzales could do the job all on his own. And they formally made the request that Gonzales be the person, and I be cut out. And that was denied by the Sphere Being Alliance.

And after that, when I was brought back up the next time, there were some somewhat forced apologies given to me. Kind of a forced make up between us, but there's still a lot of tension.

DW: So how did it come about that you get invited to this Inner Earth? And did you know that you were going to be going to the Inner Earth beforehand?

CG: Gonzales had mentioned that there had been a new Council of the Inner Earth groups that had been recently formed, and that he had been meeting with them.

DW: OK.

CG: And that I needed to mentally prepare that in the future at some point I was going to meet with them as well.

DW: OK.

CG: And then I received a communication from him, telling me that I was going to be invited to this important council meeting, and on a certain date and time, and to be ready.

DW: Well, it seems like the message of the Sphere Beings, the people that are coming out of this Space Program are not going to think you can just hum this away. They're going to want to take tactical military action, and get results right away, instead of this sort of gradual approach, where there's no real offensive maneuvers being taken as of yet. And it all leads up to more of a tribunal. They don't really want a fair trial for these guys. They just want to blow them up in a lot of cases.

CG: Right. And they're used to bombing their way out of trouble. And a lot of them, including some people like myself, are very careful about what we're saying. Because they're worried, some of them are really worried about post disclosure, post data dump, what's going to happen? What's going to happen to them when the people form tribunals and start deciding what are we going to do with all of these characters?

DW: How well did "I was following orders" work at the Nuremberg Trials, right?

CG: Right. That's not going to fly the next time.

DW: So Gonzales tells you that an alliance has formed with the Inner Earth civilizations. Now, up until this point, as we discussed in the previous taping, you were aware of a reptoid group, a raptor group. You mentioned the bald headed group. And then the Dero, with the elephant-like noses. Was this what you were thinking of when they said an alliance inside the Earth? Did you--

CG: No, I knew that it was the Ancient Earth breakaway civilizations.

DW: OK, so let's go over that. What are the Ancient Earth breakaway civilizations?

CG: Up until before I went on the meeting in the smart glass pads, they had talked about-- and it was talked about as in a handful of ancient civilizations that had arisen on Earth, formed their own breakaway civilizations, like we have now with our Secret Space Program, that had moved underground and off planet. And then during the cycle of cataclysms that happens naturally on Earth, or at least did for some time, they left the surface population to fend for themselves.

DW: When we look at Thompson-Cremo's book, "Forbidden Archaeology," it's a box. It's this book that's this thick. It's loaded, loaded, with scientific documentation about very anomalous, obviously intelligently constructed artifacts in rock strata that in some cases are millions of years old.

CG: OK, yeah. I've heard of that kind of stuff, yeah.

DW: Is it possible that those artifacts are the remnants of some of these ancient civilizations that you're describing? Because they drill down into the earth, and they find this stuff.

CG: They actually described to me about how dynamic the surface of the Earth is. It is far more dy--

DW: Who's they now?

CG: The Inner Earth people that I spoke with.

DW: OK, so we're jumping a little ahead, but yeah.

CG: Yeah. That the volcanism, the convection, the Earth is very dynamic and somewhat hostile. I mean, they talked about continents rising and falling.

DW: Sure.

CG: They were talking about when they were first on the surface, a time of much taller mountains and fewer plains. And so obviously, the Earth is changing a lot faster than what geology and archaeologists think is happening.

DW: So you acknowledge the possibility that Thompson-Cremo's research of "Forbidden Archaeology" could be documentation of ruins that these civilizations left behind as the Earth's surface is turning and churning and spinning around?

CG: According to them, yes. They claimed to have arisen on this planet, to be the first human natives of this planet 17 to 18 million years ago.

DW: So breakaway civilizations, you're saying that there were multiple phases of them?

CG: Yes.

DW: When we're saying a breakaway civilization, what are we talking about here? Is there like a great Noah's Ark type of thing, where everybody gets to flee, the whole population is saved, and they all go underground when they know there's going to be a disaster?

CG: Typically, it worked out this way. You have the majority of the population on the surface. They develop. They become somewhat sophisticated. Varying degrees, use your imagination. Then you usually have--

DW: Are you talking about technology? Do they have machines and tools?

CG: Yes, technologically--

DW: You're not just talking about stone knives and bear skins and fireplaces?

CG: No, no.

DW: OK.

CG: And I'm not talking circuit boards and that kind of stuff, but the technology they use is completely different. A technological civilization, but they have developed like the priest castes. And the elite castes developed a much higher technological civilization, spiritual technological civilization, that breaks away. They--

DW: Does that involve cooperation with intelligent civilizations that are not on Earth? Are they getting an extraterrestrial endowment of some kind that gives them this higher technology?

CG: Not according to them.

DW: Really?

CG: Yeah.

DW: So they have a decisively higher technology than what the public is even aware of.

CG: Right. And they are so much different than us. They claim not to have the aggressiveness and a lot of the problems that we have on the surface, the social problems.

DW: OK.

CG: So they were able to develop technologically a lot quicker. They have a whole different way of thinking and interacting with each other. But--

DW: Was it a classified secret amongst the priesthood that there were these habitable zones inside the Earth, and that the common people didn't know that, that there was a place that could be retreated to, where you could live down there?

CG: I would imagine so because they had built these places, and they had already begun to habitate there. And they had already developed a space program, and were leaving the Earth.

DW: Wow.

CG: And when different things were happening, there were pole shifts, there were meteors. They were describing all kinds of different--

DW: Tsunami.

CG: They were major cataclysms and minor cataclysms that they described that were--

DW: Supervolcano eruption?

CG: Yes, that was definitely one of them, that were occurring on the planet. And they would hunker down, and leave the surface population to their own devices. And then after everything cleared up, they would then go and help the survivors of the surface population.

DW: Were these worldwide civilizations? Did they have communication with each other? Or was it similar to what we're thinking happened in our own modern history, where you would have different racial groups that sort of independently spring up, but they have their own isolated, closed society, and are not in communication or trade with each other?

CG: Everything that they depicted to me was they were very isolationist. They were very-- this is a trigger word, but they were very genetic purists. They were very much about keeping their genetic lines pure, and not mixing with other tribes that rose. There were other hominids that were arising on the planet during this time period. And they were leaving them to arise and go through the cycles.

DW: The amount of fossils that we have that we've used to build the evolutionary track record of human beings that you see in anthropology textbooks, all of those bones can fit within one coffin. It's all assumptions. We see a progression of hominid forms that are evolving. There's plenty of room for there to be something that we didn't find, that we don't already know about.

CG: Right.

DW: The evolutionary timeline that we've been given is a belief system. It's based almost entirely on conjecture, and a very small amount of fossil evidence.

CG: Right.

DW: It's not like they're finding lots of these skeletons.

CG: But according to them, there were other different hominids, other species that were starting to develop. And they said that the galaxy and the solar system have a template that produces a certain type of life form naturally in zones that can support those life forms, and that there were other planets at that time in our solar system that had lifeforms, advanced life forms, on them. And on Earth, they arose here naturally.

DW: There's some new stuff that's been coming out that's really changing the game. And one of them is the Denisovans. They're finding humans that had, like, small bodies, not really pygmies, but smaller skulls when they're fully adult. And we're starting to see a picture that hasn't really percolated into the educational system, describing much more diversity in some of the acknowledged finds of skeletons, and things like that that we're now seeing. There's also, as I'm sure you know, a very robust history of giant skeletons being found.

CG: It's one of the reasons these ancient groups moved into the crust. It's because it's more stable.

DW: That's understandable.

CG: It not only shelters them from the dynamic climatic and all the changes, and all the crazy stuff that happens on the surface, but it also shelters them from cosmic rays and all kinds of other things to a certain degree.

DW: You said that there appears to be some sort of energetic field on the surface of the Earth, if I'm remembering this correctly, that causes us to age more rapidly that we're not affected by as much, if you go inside the Earth. Am I remembering that correctly?

CG: Things have changed so dramatically on the surface of the Earth over eons that we are bombarded with all different types of cosmic energy and other types of energy.

DW: Is there some sort of intelligence behind this as well? Does the Earth have a biologically active force that is going to ensure that life on the surface is subject to a certain type of aging process because of an intelligent script for our evolution, perhaps?

CG: This was a part of the Inner Earth belief system. Yes. They believe the Earth is a sentient life force being. They believe the sun is. They believe all the planets. They believe our solar system is a living being. They believe the galaxy is.

DW: Do they experience time in a different continuum? Is there a relativistic distortion of the flow of time?

CG: They seem to experience time in the same linear fashion that we do.

DW: Oh, they do?

CG: Yes. But the lady that was my hostess, she appeared to be in her 30s. She was over 130 years old. So--

DW: Maybe being shielded from all these toxic influences on the surface, the synchrotron radiation, supernovas, all this kind of stuff, pollution.

CG: And their advanced technology, what they consume--

DW: Sure.

CG: I'm sure has something to do with it.

DW: So we had described that you had a falling out with the Space Program Alliance, and that there was yelling and cursing and aggression, and that Gonzales becomes more involved?

CG: Right.

DW: So he comes to you and says the people in Inner Earth have formed an alliance. Is that a normal thing to have happened? That sounds kind of unusual.

CG: It's unprecedented.

DW: Really?

CG: These various groups have had interaction and alliances with various secret societies and secret Earth government syndicates on the surface of the Earth.

DW: Yikes.

CG: Yes. And these groups have turned against them.

DW: The groups on the surface?

CG: The surface, I mean the secret society groups.

DW: Like the Illuminati. We're saying Illuminati types.

CG: Illuminatis, yeah.

DW: Whatever you want to call them.

CG: I don't like that word because they're really syndicate criminals that are in into all these different occult kind of beliefs. But if you want to call them Illuminati, that's fine.

DW: So we'll use the generic term Cabal.

CG: OK.

DW: For those who aren't already familiar with this, maybe this is the first episode they decided to watch. And most people are familiar with term Illuminati.

CG: They love that term.

DW: You're saying that advanced humans with advanced spiritual capabilities and technology that are living inside the Earth have been lending material and tactical and logistical support to these crime syndicates on the surface of the planet?

CG: Yes.

DW: That right there is a major, major revelation.

CG: Yes.

DW: Now, a lot of these bloodline families on the surface, they got their royal bloodlines, right? So are some of these people from inside the Earth interbreeding?

CG: No.

DW: With the people on the surface?

CG: Absolutely not. They would never do that.

DW: Really?

CG: They discussed how there were other planets in our solar system that had highly advanced human type beings that lived on them that were very aggressive and warlike, and had destroyed their own civilizations, and in doing so, had attracted the attention of outside extraterrestrial groups that came in and relocated these-- I don't know. We may have to create a new term. Solar terrestrials, maybe? They're from our solar system, but they lived on other planets that were habitable at the time.

But when the planets were becoming uninhabitable, they moved the refugees to the surface of the Earth. These groups were genetically compatible with the original humans that were left on the surface.

DW: Right. With some modifications, but yeah, basically.

CG: They weren't modified yet, but they all began to interbreed together and form a mixed race, which is us.

DW: Right.

CG: And this mixed race-- all these groups mixed to make this mixed human race that is the surface race of humanity. And in addition to that, all of these what they call genetic farmer-- farming races of ETs started to come in that had not come into this part of the galaxy previously, began to flood in, and started to start a new experiment tinkering with all of the genetics of the surface population.

DW: And that's the Great Experiment, these 22 genetic programs, and the Super Federation.

CG: Part of the Great Experiment. The Great Experiment goes far, far beyond that, but it's part of the Great Experiment.

DW: OK.

CG: And the subterranean groups were using them. They were trying to give them civilization, and boost them spiritually.

DW: Which may not be what these genetic tinkerers wanted to do.

CG: Right. In a different, a competing kind of agenda.

DW: OK.

CG: And this went on for some time. There was often open conflict between the subterraneans and different ET races in the skies and in space.

DW: Wow.

CG: And this, they say this occurred off and on all way up until even in our current history. People in our accepted current era of history have witnessed the below Inner Earth groups in open warfare with extraterrestrial groups in battle.

DW: If they've been down there for millions of years genetically isolating themselves from one another, they've got their own little civilizations. Maybe they have subshuttles or portals. We'll get into how they go from one place to another, if they've got different cavities of the Inner Earth that they're living in, why now? Why would they form an alliance with each other after maybe warring with each other or separating from each other for so long? What has changed?

CG: What has changed is the secret societies that they used to be allied with have turned against them. We have to go back to the major changes that happened on the surface.

DW: OK.

CG: After the Draco came out and offered to turn over all their subordinates, human and non-human, to the Alliance for safe passage out of the solar system.

DW: Which is so insanely treasonous against their own allies of every level other than the highest royalty.

CG: Right. After that--

DW: Total betrayal to everybody. Sends everybody into disarray.

CG: Yeah. That things went into total disarray.

DW: That shocking betrayal, where the Draco royals say we're going to give you everybody. You can take everybody you want. Just let us go. Throws everything into turmoil. And I'm assuming what you're saying now was that that includes the Cabal folks, the human Cabal folks now turning on their former allies inside the Earth, and doing what? What did they do? How did they turn on them? That's the part I'm not getting yet.

CG: There's other groups below the ground. A lot of these different ET groups have what they're calling embassies below the ground and below the ocean. But they're really just bases.

DW: This could be insectoid types, reptilian types?

CG: And all the human-ish types from--

DW: Right

CG: The Super Federation. There's all types of embassies.

DW: So there's a lot of places you can live inside the Earth?

CG: Right.

DW: And people do.

CG: Right.

DW: "People" in quotation marks.

CG: All of a sudden, there started to be a lot of skirmishes that started to occur between enemies that they've had under the ground for a while. And they said that the surface humans have developed technologies that can now get past their defenses.

DW: They meaning the Inner Earth Alliance said?

CG: Inner Earth Alliance.

DW: OK.

CG: They have weapons that can penetrate deep into the Earth's crust and reach them. And this is very much of a concern to them.

DW: What is this alliance? Let's just spell it out in basic terms. How many groups are in the Alliance? Are the reptilians in the Alliance? How did this form?

CG: In the--

DW: The Inner Earth Alliance.

CG: Oh, no, no. These are all people that are Ancient Earth breakaway civilizations that claim to be humans that developed naturally here on Earth, were not seeded, were not genetically modified, GMO. And they are ethnically diverse from each other, most of them. There are seven groups.

DW: Seven different groups?

CG: Yup. Three of them were related, but not, I guess you could say, cousins related. They all wore the same symbol. It was a symbol of Saturn.

DW: The three that were related.

CG: That were related. And they just had a different jewel from wherever group they were from. One had like a black stone at the 3 o'clock position. One had a jade at the 9 o'clock position. And down at the 6 o'clock position, was a rose red.

DW: So this alliance is not reptilians.

CG: Human, human, human.

DW: Human breakaway civilizations. What is the gulf of time of when these different groups evolved? You said some of them have been here for 17 or 18 million years?

CG: This group with the Saturn emblem.

DW: OK.

CG: They claim to be the oldest, and they were the ones hosting this meeting, this council meeting.

DW: Are there other groups that are a lot more recent than that in our terms?

CG: Yes, like groups that are a half million years, and I think the most recent was-- I think it was two or three ice ages ago. I can't remember how many tens of thousands of years ago that is.

DW: So these changes have led them to want to form an alliance. Now, if the spheres are showing up in our solar system, and they're erecting an outer barrier so nobody can get out, you became the voice through which these Sphere Beings were going to talk to the Space Program. They wouldn't talk to the Space Program directly, I guess because there was a vibrational incongruity or something.

CG: Yeah, yeah.



DW: They didn't want to talk to Cabal people directly.

CG: They don't want to give a talk directly to the Super Federation group, the Draco group, or the subterranean group.

DW: Oh, so the subterranean group was in that category as well?

CG: Right. And that's why they wanted to talk to me.

DW: So if they want access to the new kids on the block, they're going to have to go through you.

CG: They were talking to Gonzales first.

DW: And Gonzales. OK.

CG: And then that was the reason they were wanting to talk to me. They wanted to know why-- they call the Sphere Being Alliance, they refer to them as the Guardians. They wanted to know why the Guardians would not interact with them one-on-one.

DW: All right, so Gonzales starts having meetings with them, and you're not involved.

CG: No.

DW: So how let's walk it through now. What is the first thing that happens? Do you get told a couple days ahead that you're going to be going on this trip? How much notice did you get? Let's walk through it.

CG: I was just told a time frame that it was going to occur. I assumed that it was going to be the Blue Sphere picking me up as usual.

DW: OK.

CG: I got up, was ready for this to happen.

DW: And you were given a time to wake up? Like, a window?

CG: Yeah, he always he says same bat time, same bat channel. It's usually the same time. And it was past time that I usually would see the little Blue Sphere come in the room. And I was thinking, OK, there had been times in the past where a meeting was supposed to occur, nothing happened. And I stayed up. I got up early for nothing.

DW: So would you get dressed when you get out of bed?

CG: Yes, and usually I just wear something real simple. I don't get dressed all up like this.

DW: Do you get to bring a backpack or anything with you?

CG: I can't bring anything with me.

DW: OK. So you get simple, simple dress.

CG: And usually I arrived at the LOC, and then I get a jumpsuit or something else to wear. I was expecting the same kind of thing. I was given no information.

DW: So now you're twiddling your thumbs and whistling dixie, going what the heck's going on here?

CG: So I go to the living room, and I decide I'm going to go to the couch, get on the internet, twiddle around on the internet, and see what's been going on. And a bright flash of light, just a bright flash of light, and I'm still--

DW: Like, blinding white?

CG: Just blinding. Yeah, a flash of white light.

DW: OK. Did you feel electrical sensation or any type of prickling or tingling or anything?

CG: Yeah, it was a static. And all of a sudden, I could feel I was in a just totally different-- the pressure changed. The environment was totally different.

DW: Like, the air pressure?

CG: Yeah. And just the whole environment.

DW: How did it feel that it changed? Was it more pressure or less pressure?

CG: Less.

DW: OK.

CG: And I could smell stone and mineral--

DW: And water.

CG: And my eyes were kind of blurry, and I was looking. And I could see I was in a giant, domed-- huge, domed room made of granite. And the ceiling, I mean, guesstimating 100 feet tall. And it was huge. And there were four doors.

DW: How wide was the room would you say?

CG: Probably 100, 150 feet.

DW: OK. And so when you say a granite room, is it made out of blocks?

CG: No, It was polished, all one piece polished.

DW: Polished, like gleaming mirror polished?

CG: Yeah.

DW: Really?

CG: Yeah.

DW: So that's a technology we wouldn't have here, obviously.

CG: No.

DW: And what was the color of the granite?

CG: The granite was a dark brown, and there were four doors at each side with people standing on either side of the door. And I was standing there, not knowing whether to call out, because they didn't look at me or acknowledge that I just--

DW: And there's guards at each door?

CG: Yes.

DW: How many guards?

CG: Two, standing on each side of the door.

DW: What do these guys look like? What were they wearing?

CG: They were wearing white robes with pendants, different pendants at each--

DW: Like amulets on a necklace?

CG: Mm-hmm.

DW: OK.

CG: And get my eyes were still adjusting when I saw a group of people coming out of one of the doors. And then I realized that Gonzales was there.

DW: Well, when we come back in the next episode, we're going to get into what actually happens to you once you get into this area, and all of these amazing things that take place. So that's coming up next time here on "[Cosmic Disclosure](#)." Don't miss this next episode. It's going to really rock your world. And as always, we thank you for watching.

[Cosmic Disclosure: Ubuntu and the Blue Avian Message Part 1](#)

Season 3, Episode 3

DW: Hello. Welcome to [Cosmic Disclosure](#). I'm your host, **David Wilcock**. And we have a special guest for this episode, none other than **Michael** Tellinger.

He is well-known if you don't already know this, coming out of South Africa with some very interesting research into ancient ruins that are quite extensive and very unique to the South African area. There's some really interesting stuff in Zimbabwe and other places. And it's all woven together into his research, which has now led him into a very unique view about the economy.

And if you're also a regular on the show, you know **Corey Goode**, coming out of the Secret Space Program, has been in contact with an Alliance that is a part of this breakaway civilization out in space. The Alliance is saying that what they want is to release technology that will utterly transform life on Earth as we know it and bring us directly into a Star Trek-type golden age that is predicted in 35 different ancient cultures around the world as revealed by Giorgio de Santillana and Hertha von Dechend in their epic classic "Hamlet's Mill," which was then paraphrased and renewed by Graham Hancock who's one of the real inspirations for all of our work.

So I wanted to bring **Michael** Tellinger onto the show in order to help explain this economic system that he has devised, which has taken a keen interest to buy the Space Program Alliance. So first what we're going to do is talk to **Corey** about the Alliance, what is the alliance, define the alliance, and how this thread that **Michael** Tellinger has brought into the picture weaves into this greater tapestry of disclosure that we're bringing out. So **Michael** thanks for being here.

MICHAEL TELLINGER (MT): Thank you, **David**. Good to be here.

DW: All right. And **Corey**, thanks for being here too.

CG: Thank you.

DW: So let's just, **Corey**, start briefly with, if somebody happens to be watching this episode for the first time, they're looking at what they might call the Illuminati or the New World Order, and they're saying this is some impossible thing. Nobody's ever going to be able to stand up to these guys. What is the Alliance exactly? And do they have a chance to ever bring down the Cabal? Or is this just a pyrrhic quest that will never succeed?

CG: They definitely have more than a fair chance. The Alliance is made up of two main factions. There's the Earth Alliance, which is made up of different societies, secret type of societies and groups that work loosely together. And they're working to overthrow the current financial system and the system that is run by what I've described as the secret Earth government and their syndicates.

And many of these syndicates are very much into the occult. And they're the groups that people call the Illuminati. We call them what they are-- syndicates. We take the mystique out of it-- the mystery.

DW: Syndicate like the mafia, like organized crime?

CG: We call them what they are.

MT: Exactly.

CG: And there are different agendas for the Earth Alliance and the Secret Space Program Alliance. The Secret Space Program Alliance has-- it's slowly built up started with certain members of the different Secret Space Program groups, breaking apart from the leadership and forming a kind of a loose-knit alliance to where they formed what they call the Secret Space Program Alliance Council. And--

DW: In case somebody doesn't know what the Secret Space Program is, what kind of technology are we talking about? What do these folks have?

CG: Well, there are different Secret Space Programs that there's a wide variety of technologies. They have some that are just 20 to 50 years ahead of what we see flying around that the Air Force and NASA is using. And then they have aspects like the Interplanetary Corporate Conglomerate that is basically all

of the corporations that have come together, pooled their resources, and created a vast infrastructure in our solar system.

DW: And these corporations are the military defense contractors, primarily.

CG: Primarily, but it branches out into many others.

DW: So faster than light travel, Stargate-type technologies, particle beam, pulse laser weapon-type stuff.

CG: They've moved even past that, but yes.

DW: So this is highly advanced technology. It's all been developed under the umbrella of extremely high security classification.

CG: Yes. And the Secret Space Program Alliance, it is-- their major goal is to bring, what they call, full disclosure to the population of the Earth. And full disclosure is not just, there are aliens.

We've been lying to you for the last 80, 90 years. OK. Move on with your lives.

The full disclosure event will be a data dump from Edward Snowden's information, a few of these other major hacks that we've heard just a little bit about. All of this information has been decrypted and collated, handed over to the Earth Alliance and to the Secret Space Program Alliance ready for a massive data dump at a certain point. And what they want to do is reveal all the crimes against humanity that these syndicates have done in order to prevent, not just the fact that there are ETs, non-terrestrials out there, but to cover up technologies that would have changed our lives in a dramatic way and would have collapsed their corporate regimes and their Babylonian money magic system-- slave system-- over the Earth that they use to control everybody on the surface.

DW: OK. Let's just get really real for a second. What the hell are these people thinking? Why do they want to kill people? Why do they want to depopulate the planet by billions? This is what makes people unable to actually see that this is real. They just can't wrap their head around, what the hell are these people doing?

CG: Not all of these syndicates have this same agenda. I've described that there is a Super Federation of non-terrestrials that have been here for eons that have been involved in 22 different parallel but

competing programs that have been manipulating Earth humanity. And it's been on a genetic, social, and spiritual level. And they themselves are a part of this grand experiment, they call it. Now there are some more benevolent non-terrestrial groups that have a, I guess, an agenda that we would consider positive.

DW: Sure.

CG: And there are some that have a very genetic purist type of agenda that people fall outside of a certain small realm. They want to cleanse off of the Earth and start anew with a small group. But it is not all of these syndicates that are pushing for this depopulation. It just happens to be some of the ones that are the most powerful and some of the ones that are-- like the committee of 200 that I've talked about-- that have a lot of power and run the financial system.

DW: You have an advantage that **Michael** and I don't have, which is that you've met with a number of these people, you've looked them in the eye, and you've heard their arguments about why they think billions of people should be killed. The people who believe in that, how could they want that? What is their agenda? Why do they want so many people to die?

CG: It's not that much different than the Nazi-type of ideology. So many different of these non-terrestrial groups have a genetic purist kind of ideology or a genetic purist part of their experiment. That's why a lot of them, going back thousands of years, they did not want inter-tribal marriages or mixing of tribes. They would have one tribe, if it came across another tribe, wipe out the entire bloodline of another tribe.

This is something that's gone back a long time. These are programs that compete with each other. And they, in more recent times, they've come together and found a way to work alongside each other a little bit better. But there are the syndicate groups, the occultic syndicate groups here on the planet that are humans that feel that they come from a bloodline that is non-terrestrial, and that we are all from a polluted worthless bloodline and that we should be wiped.

DW: So when they use terms like "useless eaters" and "sheeple," do they feel that they could control the planet better if there were fewer people here? Is that part of it?

CG: Part of it. Yes. And they put a lot of platitudes in that it would put the Earth more in balance with nature.

DW: Humans are bad for the environment.

CG: Right. When they know full well that we have the technologies that-- if the Secret Space Program wants to bring down technologies, such as replicators that would feed people, free energy, healing technologies that work off of light and sound frequency, a whole lot of different technologies that will improve the lives of people and help them live in balance with the planet. And this could be brought down, implemented with all of humanity immediately. And they don't want to bring it to the Americans and the British and then let it trickle down to the other members of the planet. They want to bring it to everyone on the planet all at the same time.

DW: All right. Let's start blending why we got **Michael** into the discussion here. And I'm going to ask you one question. And I want you to answer it, and then we'll open it up.

Some of the most controversial stuff that you and I have talked about in the show is the idea that we don't really need a financial system once these types of technologies come out. You've often dropped the term that the Space Program Alliance uses the Babylonian money magic system. What's so bad about money? How is the financial system a tool for control by these secret Earth government syndicates that you've been describing? How do they use money against us?

CG: When you have money, you have debt. When you have debt, you have servitude and slavery. You have people that are of the haves lending money to the "have-nots". And the "have-nots" are the ones that end up carrying all of the burden. And that's the way that it's been set up to work from the very beginning.

And we've been so highly programmed for many thousands of years to believe that you have to have this paper folded up in your pocket. People have heard me talk, and they freak out. You want to take away our money. You want to move to a cashless society.

This is crazy. What are we going to do without money? How can you have a society without money?
And--

DW: But how are what you--

CG: They can't fathom it. They're so highly programmed, they cannot fathom it.

DW: But how is what you're saying not communism? Aren't you going to have a group of oligarchs that absorb all the wealth, and then everybody gets paid the same, and therefore, nobody has any incentive to do anything?

CG: Or you're using the word paid. That would denote that there's money involved. When everyone has everything that they need-- I mean if you really want to have money or gold, the replicators have the ability.

You could synthesize a little bit of gold or synthesize an old 20th century \$100 bill and carry that around in your pocket if that makes you feel more secure. But you're not going to need it because everything is going to be based off of bartering skills, people sharing their knowledge and abilities with each other as a community, and it's going-- and everyone's going to have what they need through these technologies. You're not going to need to work 9:00 to 5:00 to pay an electricity bill-- free energy. I mean you're not going to need to have to buy groceries-- replicator technology.

DW: Hold on right there. These people in space, these Space Program Alliance people, they mentioned to you before you even knew the name, **Michael** Telling and Ubuntu contributionism. What were they saying?

Why did these people who live up in space, who may not even ever come to Earth-- why do they care about this guy right here? What was the interest that they had? And if they have all these technologies, how does what he did have anything to do with that?

CG: To be clear, I had heard of **Michael** Telling and some of his work in ancient civilizations and some of the studies that he had done. And I had found a lot of that very interesting. I had no idea of the political movement thing that he was doing until it was brought up in a situation to where Lieutenant Colonel Gonzalez was there. And they were talking about **Michael** Telling in the Ubuntu-- did I say it right?

DW: That's It. Well done.

CG: Thank you. Movement, and how they said that this is the wave of the future and that this after there was going to be a catalyst event. There was going to be a full disclosure event. And after the monetary system is gone and capitalism, all the isms are gone, this is going to be the type of system that we're going to move into and use as we're a transitional civilization moving to be like a Star Trek

civilization.

And as we're integrating and learning all of these new technologies exist and integrating them into our lives. And they said that they have been following this movement with great interest. And I thought it was very interesting. And I don't know what Mr. Telling has to say about that.

DW: Well, **Michael**, let's dive right into it here. Assume for the moment that whoever is watching this doesn't know you, hasn't seen your work before. Could you give us a short summary of Ubuntu contributionism, and what that is, and how it factors into our lives today.

MT: Thanks **David**. Sure. And there is an ism here, but it's a very different ism from all the other isms that we've ever heard of. And it's the contributionism part of Ubuntu.

First of all, Ubuntu is an African word. It's an ancient philosophy of sharing and caring. I've defined it as unity within community.

And the often used definition of it is, I am who I am because of who we all are. So this is an ancient African philosophy which is shared by all ancient cultures around the world. They have their own names for it and their own expressions for it, but it ultimately comes down to the same philosophy of unity consciousness-- sharing and caring for each other.

So the Ubuntu movement was started with sharing knowledge, as **Corey** said, and information about the origins of money and how money is being used to control and enslave humanity. And then at the same time present a solution for the system because I think that the days of fear and just talking about how bad it is are over. We need to start presenting a solution. So that's really what this movement is all about-- presenting a solution that resonates with peoples, not only in their minds, but in their hearts, specifically.

And it seems to be that, for some reason, I've become the messenger of this. This is not my system. It's not my message. I'm just the messenger.

And it's interesting for me to hear that it's being spoken about in other areas that I wasn't even aware of. Because I've been getting some interesting e-mails from people around the world mentioning things to me about prophecy and all this, and how Ubuntu features into it, and how the work that we're doing

features into it. And it's taken me by surprise, but I don't really want to go down that route. It's just interesting to note. Let's carry on with the task at hand.

There's a lot of work to be done, and we need to-- what we're doing is providing an alternative solution. The system we've had for the last 6,000, 12,000 years has not worked. It's been a system that was designed to enslave us, using what **Corey** calls a Babylonian magic money system.

Money is a tool of enslavement. That's all it is supposed to do. And I remind people all the time about the fact it's not about the money. It's about the use of money as a tool of control.

Those that control the money can create as much money as they want because there's nothing backing it. It's just money out of thin air. So it's about keeping the control of the supply of money on the planet. And that's how you control the planet.

DW: Even in the biblical book of Genesis, it sets up right at the beginning explaining that the money system is this evil force.

MT: Yeah.

DW: If you actually read it carefully, it's right in there. If we had Jordan Maxwell right here to talk to us, one of the things he said that was so shocking was that these numbers that you see on the Federal Reserve note, the US Dollar, he calls them stock numbers. And he says, every person in America is given 10 different stock numbers. And you worked at the Federal Reserve, so I'm sure you know what I'm talking about.

And that these numbers on the money, each person has a certain number, a certain quantity of money issued to them-- I guess 3.4 million was, I think, one of the numbers I heard. So that when you see any given piece of money, it's somebody's soul. The number actually corresponds to somebody's soul. So when they're stealing the money--

MT: It's amazing.

DW: They want to be stealing our souls.

MT: Yeah.

DW: How do you see this-- what is the black magic of the financial system? What are they doing?

MT: You just described it, you know. The money system is somehow has been imbued in ancient times with some sort of a black magic component because look what it's done to our planet. Look what it's done to humanity. People go crazy.

As **Corey** said upfront, you know, when you say to people we're going to remove money from the system, they go-- start going crazy because they imagine we're going to take their money away. That's not what we're saying. We're saying we're going to create a new system that doesn't work with money. So nobody needs money.

And this is where the whole introduction to a world transitioning from a world that's driven by money and greed, and corporate structure and control, and scarcity, move from the money driven system to a system that's driven by people and their passion for life. That's what the whole Ubuntu movement is about. And slowly but surely introducing people to the fact that we don't need money because money does nothing.

People do everything. It's about the people. We grow the food. We plant the seeds. We create the mathematical equations and develop the free energy devices.

And we do everything. Money does nothing. It just keeps getting in the way of people expressing their passion and living out beautiful lives.

DW: Well, if we had Darth Cheney sitting right here, he's-- and he was going to talk off the cuff--

MT: Yeah.

DW: He's going to say, as soon as you take away people's need to earn money, they're going to drink beer, and they're going to sit and watch TV all day.

MT: Yeah. That's in a capitalist-driven system. We're changing the system, changing a system where people live out their lives and express their talents that they are born with where they don't have to worry about money. What you mentioned there, **David**, is one of the, what I call, the 13 frequently asked questions. And out of 11 years of work of talking and exploring a new way, a new social structure that works without money, I've filtered it down to 13 frequently asked questions.

It's incredible. In a world with money, we have an insurmountable number of problems. And our governments and our banking, financial guys can't solve the problems we have with all the money in the world. And in a proposed world without money, over a period of 11 years since 2005, it's filtered down to 13 problems we have to solve in a world without money to live in paradise.

DW: My parents bought the house that I lived in and grew up in starting in 1973 for \$26,000. Now that's a joke.

MT: Yeah, exactly.

DW: The US dollar has decreased in value by 96% in the 100 years since the foundation of the Federal Reserve System.

MT: Well, there you've just mentioned the big scam-- the reserve banks, the central banks of the world. Now for people that aren't aware of this, all the central banks of the world are private companies. They control our governments. It's like, our governments are indebted to these private companies, and they use all of us as their slaves.

So part of the teaching and the sharing of information with the Ubuntu movement and Ubuntu party is first telling people about the origin-- firstly, the origins of money, as **Corey** calls it, the Babylonian magic money system, where money first appears. That it was maliciously introduced, that it's not the consequence of thousands of years of barter and trade. It is a maliciously introduced tool of enslavement that gives the people the illusion and the belief that they are free, but they still have to work for money so that they can live and pay their taxes.

So if you change this whole system-- and this is why I do the Ubuntu workshops, where after a day or two days of an Ubuntu workshop going through all these processes, it's turned out now that it's become like a group therapy session for people. And this is the last thing I expected because people are suddenly feeling the sense of release and relief.

Oh, my God. We don't need money. I see what you mean. And they not only understand it. They understand the origins of it, the reason how and why it was introduced, and how it was twisted as a tool of enslavement, and what we can do to get ourselves out of it.

And with this comes the good news. This is where people really start getting excited when they see how simple it is. How we have-- just by undoing some of the programming and the conditioning and the brainwashing that we've had to go through, that we've gone through for thousands of years, and especially the last 100 years or so with the current education system that was set up to do all this damage to us to turn us into a future labor force. Once people realize that how simple it is to get ourselves out of this mess, that's when you see the deep realization.

DW: So **Michael**, don't you think that-- let's say the dreaded global economic collapse occurred. The sun still rises. The sun still sets.

There's tides. There's rain. There's crops that are going to grow. We have what we need here.

MT: Exactly.

DW: If these people are saying all the money is gone, where the f did it go? It's ridiculous. The resources are here. We're living in a very abundant world.

MT: Yeah. Well, this is one of the things that you need to remind people of many times and, sometimes, over and over again. That we live on a planet of abundance. We've been taught-- we have now been led to believe that we live in a planet of scarcity through the corporate hierarchical structure.

And this is all to do with the principle-- and this philosophy has been shoved into our heads since the earliest days, is that competition is what we need to have progress. You know that competition drives progress, competition drives innovation, competition drives people's desires to succeed in all that. That is the poison pill-- sugar-coated poison pill that we've been given, falsely believing that that's how things work.

No, no, no. Competition create scarcity. Competition makes corporations hide things, so they can benefit from the knowledge and information, the technology while the rest of the humanity suffers.

Competition prevents new technology from being released-- petroleum, electricity, cures for disease. You understand, well, this is why competition is so bad. So the whole thing with Ubuntu and

contributionism is just switching that one little thing around, turning competition into cooperation and collaboration.

DW: If you think about where the New World Order's view of their own high level of evolution comes from, we see Charles Darwin's father was a 33rd degree Mason. Darwinism says that the most effective killer is the most highly evolved, the survival of the fittest. Yet if you look at the eukaryotic model of the cell, we have little microorganisms that at some point in our distant past came together, formed a membrane around themselves.

You be the ribosomes. You be the chromosomes. We over here are going to do the nucleus. And they had to work together and pool their resources to get a better result.

MT: Exactly.

DW: It's the nature of life itself is to create individual cells that communicate and form organ systems. And the organs come together, and they form a body.

MT: Yes. You took the words right out of my mind. This is part of the Ubuntu teachings, if you can call it that, is to tell people that only out of unity will you ever attain infinite diversity. We have to come together as a group of living, breathing human beings and realize that together, out of our united efforts, we can then diversify into an infinite number of resonant, fractal activities as long as we resonate together at the core center.

From that resonant center, we can diversify into an infinite number of fractals because we still resonate together. The moment we have dissonance, we have disease, and we are fractalization. And we have breaking up and death and destruction.

DW: If you built a computer that had a CPU that was in competition with the memory--

MT: Exactly. So this is what I often show in my workshops, and that is think of your body and the trillions of cells in your body that all work together for the benefit of the community of cells-- your body. They're not fighting each other.

CG: Symbiosis.

MT: Symbiosis. Cooperation. Working together. And even if the trillions of some of the cells group together into specialized cells, like your liver or your heart or your brain, they're still working together for the greater good of the whole body, the whole community of cells. We've got to start seeing ourselves like this and seeing ourselves in our families as the extension of the cells in our body and our communities-- the extension of our families.

CG: I can fully see why those in the Secret Space Program Alliance council have been following this. And also it goes back to the Blue Avian message that they've delivered. And there's been a lot of people out there that have been under the misunderstanding that this is a new ET race, savior race that are coming to save humanity. And there's a lot of people that are sitting back waiting for some light forces or some group to come and save humanity.

And the Sphere Alliance, they're out there to help even the playing field, but they've made it very clear that, like the Hopi said, we are the salvation that we've been waiting for. That we are responsible for clearing up our own mess to coming up with the solutions, to defeating the Illuminati-Cabal secret Earth government groups, coming up with a new system, implementing the new system, and starting over with a new transitional society. And that it is up to all of us to stop pointing out all of our differences, all the things that make us different, all of the things that keep us apart and start focusing on all the things that we have that are similar that will bring us into a symbiotic relationship.

And the idea of forgiving other people, becoming forgiving of ourselves. There's a lot of forgiveness that needs to happen between tribes and nations. We need to move past that and start working on projects like the one you're talking about in detail that will help us come together and solve these problems ourselves after doing the inner work and come up with the solutions ourselves, instead of waiting for it to be done for us, because it will never happen otherwise.

MT: Again, you took the words right out of my mouth. I always tell people in my workshops, in the Ubuntu workshops, that we are the ones we've been waiting for. We are the wave of the New Age. And we can't sit on our backsides and wait for somebody to come and save us.

And this is always a problem. People are waiting for some sort of a knight in shining armor, some external savior. We have everything encoded in our DNA.

We are co-creators of our own reality. So let's create this own reality. Let's focus on a positive outcome

for humanity. Let's stop fear mongering. Let's stop talking about the dark, negative stuff.

Well, we can talk about it, but as a platform of knowledge and information that we then use to launch ourselves into this new utopian world. And I like to use the word utopian, specifically, because utopian is a good word. It's not a bad word. Oh, it's just a utopian idea.

Yeah, I like “utopian”. It's a good word, right. Let's use “utopian” more.

And I just want to also add just because we mentioned the word like barter and all that stuff. So I want to firstly say that the whole Ubuntu contributionism philosophy is not a philosophy about creating self-sustaining communities. It's creating communities of abundance because we live on a planet of abundance.

One apple tree creates 1,000 or thousands of apple trees, not one other apple tree. And this is what we are capable of. Each one of us is capable of creating infinite abundance if we are left to create and do--express our natural talents that we are born with.

So it's creating communities of abundance and not bartering or trading or replacing the money system with any form of exchange. As long as you've got any kind of form or exchange, it is open to exploitation. And somebody will find a way to use that against the people for their own benefit.

DW: All right. Well, I'm sorry to end it right now while it's just getting good, but that's all the time we have for in this particular episode. We're going to be back next time continuing this fascinating discussion with the insider's insider, **Corey Goode**, and with **Michael** Telling, the face behind the Ubuntu movement. As always, we want to thank you for watching. And we'll see you next time.

Cosmic Disclosure: Revelations From The Inner Earth

Season 3, Episode 4

DW: All right. Welcome to [Cosmic Disclosure](#). I'm your host, [David Wilcock](#). I'm here with **Corey Goode**.

So where we left off was that you see a group of people come towards you, and apparently one of them is Gonzales. And he's now wearing the same costume, if you want to call it that, that everybody else is.

CG: Yeah.

DW: OK. So let's start there. What happens next? How many people came towards you?

CG: Including Gonzales, there were five.

DW: OK.

CG: And about halfway to where I was standing, the four-- four of the five stopped. One being-- the one of the five, being Gonzales, continued, walked towards me, greeted me. I stuck my hand out to shake his hand. He put his hands up and told me that he didn't want to have to go through the cleansing ceremony again. Basically, he couldn't touch me.

So-- and then he told me that I was gonna have to go through a cleansing ceremony, and we started heading in the other direction. There was a woman and three men that were all together with their-- they had hoods up.

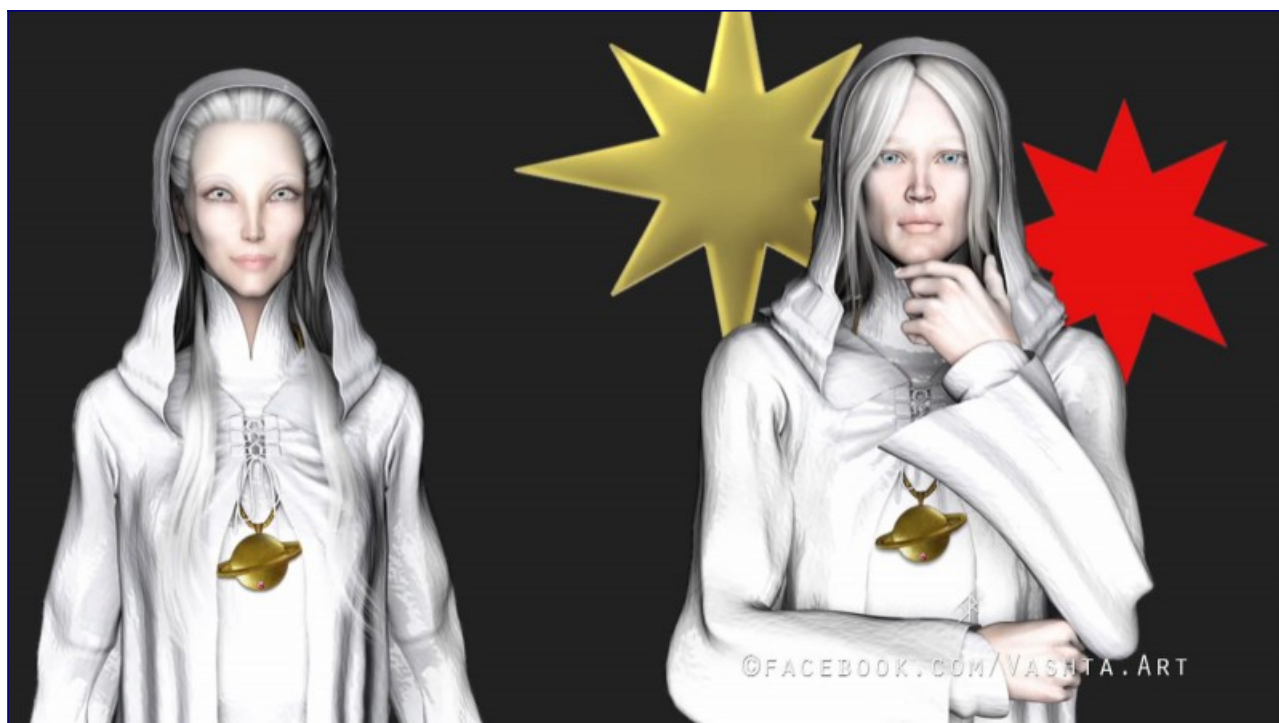

CG: And she had white hair, eyes that are just slightly larger than ours that were blue.

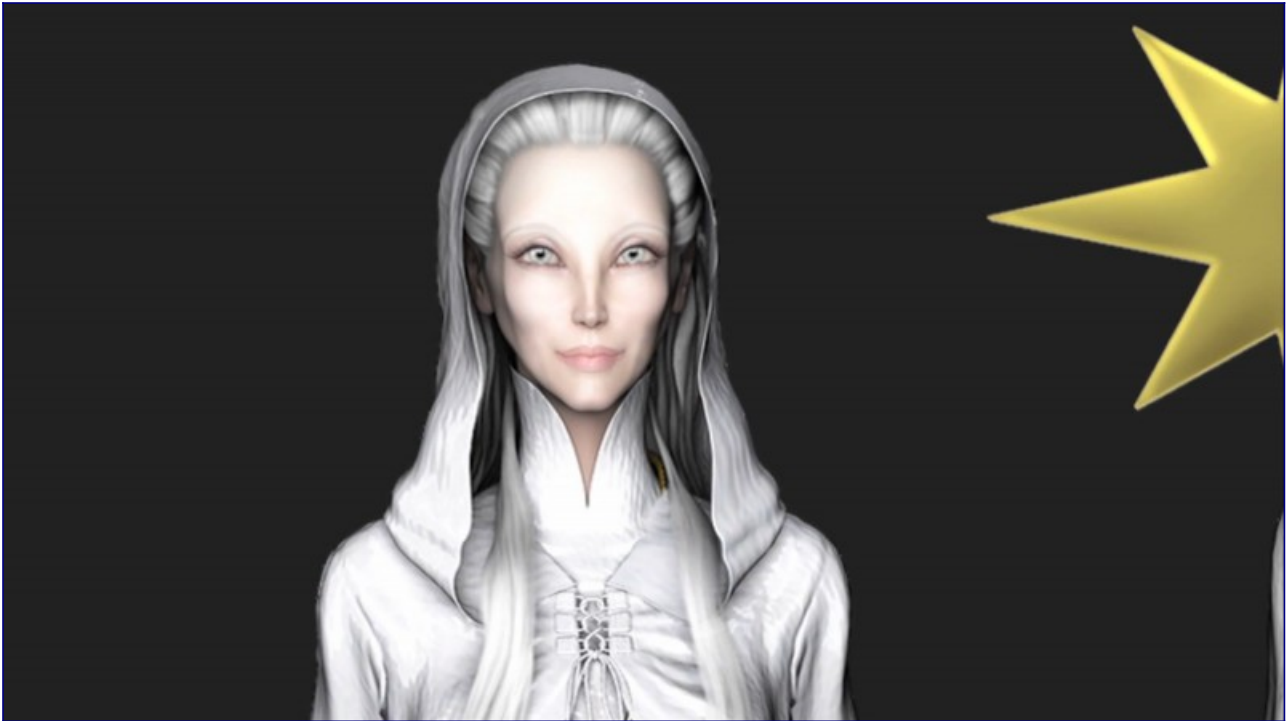

DW: OK.

CG: And very pale skin, and I could see white hair under the--

DW: So would she be--

CG: And she was my-- I'm just a hair under 6' 1", and she was my height, and they were wearing flat-footed sandal shoes.

DW: Was she disturbing or unpleasant to look at?

CG: No. She was stunning.

DW: OK. So she's a very beautiful woman.

CG: She was attractive. Different looking, but attractive.

DW: What was different about her?

CG: She had narrow features. I mean, she was just narrow-- narrow features, the larger--

DW: So her face was narrower?

CG: Yes. And the larger eyes. She's pale. The white hair. I mean, she obviously looked different.

DW: So if you saw somebody like this walking around, you'd be, like, whoa what's going on with that lady?

CG: She would get your attention, yeah. She's not going to walk among us without being noticed.

DW: Right. So-- and the other people that you saw, what did they look like?

CG: In her group they had white hair, blond hair. Some of them had brown hair, and some of them had black hair. They weren't all exactly the same with the white hair. Some of them had different-- she was real tall and not really frail looking, but very thin. Her hands were real thin. I mean, she was just real thin.



DW: Was the narrower face also consistent among them, or was that more just her particular look?

CG: Most of them. There was some of them that were somewhat-- a little bit shorter, closer to our height, and a little bit different body, a little bit more meat to them, that wore the same symbol.

DW: And what was the symbol they were wearing?

CG: Saturn symbol that was gold. There were three different ones. The people that were obviously hosting it had a stone that was kind of a red roseish look at the six o'clock.



CG: One group at the three o'clock position had a black stone.



CG: And the other group had a stone that was jade.



CG: And they were-- all three of these groups were genetically cousins, related, and worked together-- were a group. Some sort of related group beyond all the other groups.

DW: So did you walk through one of these four doors to get out of that room?

CG: Yes. At that point, the woman and two of the men had already left, leaving one man standing. And--

DW: And nobody spoke to you other than Gonzales?

CG: No.

DW: So it's this weird quiet kind of vibe.

CG: There was a lot of that.

DW: Like a meditative, monastic silence or something.

CG: Yeah. This was a temple complex.

DW: OK.

CG: So they were-- this was a very ceremonial kind of thing.

DW: Right.

CG: We go through the door, and it looks like the tunnel ends at a certain point, but it actually continues going down.

DW: So there's a tunnel after the door?

CG: Right. It's a carved corridor, as if it's molded or laser cut, just like the room was.

DW: All granite, polished.

CG: There's light, and I'll talk about the source later. There's light coming-- there's light everywhere. No shadows. It's just lit. It's perfectly lit. So anyway, I could hear the sound of water, and kind of the smell of wet stone and minerals and that kind of a smell.

DW: Like you're in a cave.

CG: Right. And as we were heading down the hall, there was apparently-- there was a door there. And on each side of the door was an eight pointed star. One was gold and about the size of a hand outstretched like this. And slightly smaller on the right side of the opening of the door was a red eight pointed star, slightly lower.

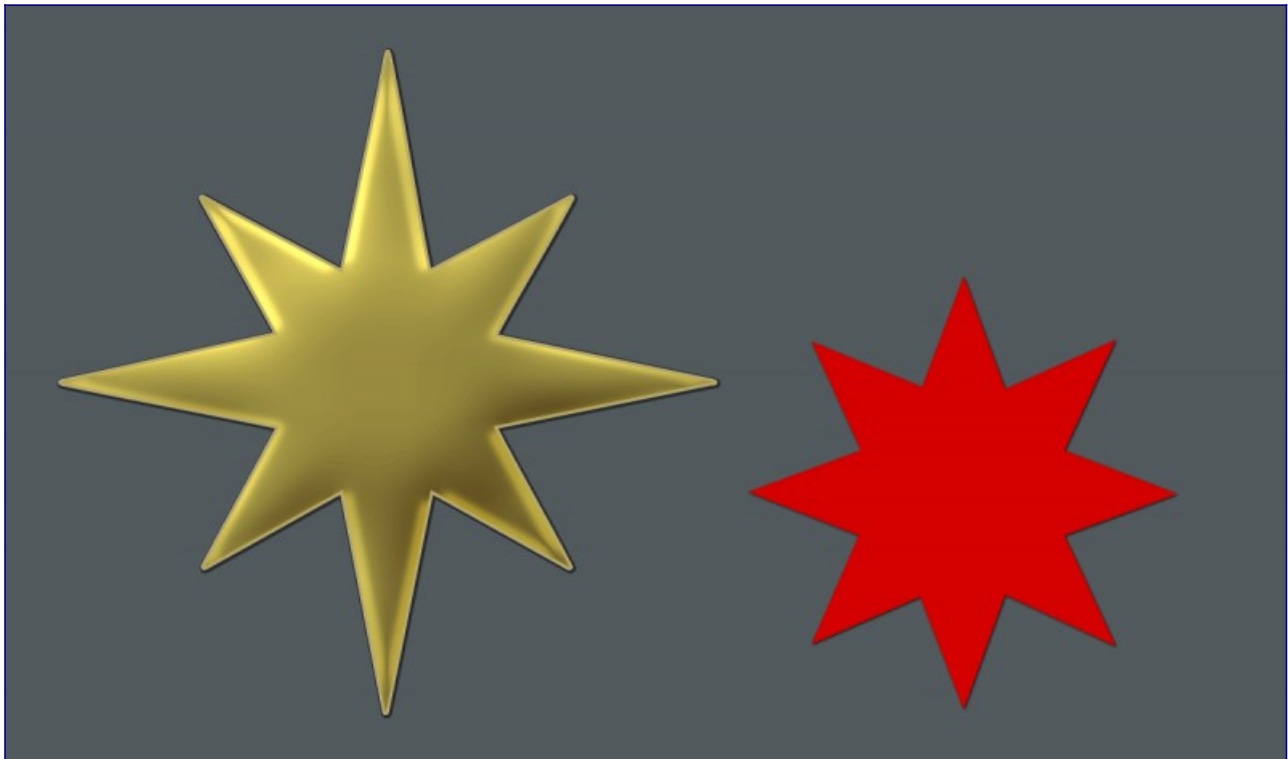

CG: As we're heading in, I immediately-- I mean, you can feel like a-- there's a slight breeze in the room.

DW: As you go through this door? Was it on the left or the right?

CG: Left.

DW: OK.

CG: And the room's lit up just like all the other rooms. It looks the same.

DW: So with the same size ceiling, the very tall ceiling?

CG: No. It's not as tall.

DW: OK.

CG: But it's domed. And out of the-- as it comes close to the area of where it goes flat up to the dome, there was a port that water was flowing out of like a waterfall.

DW: Like a hole.

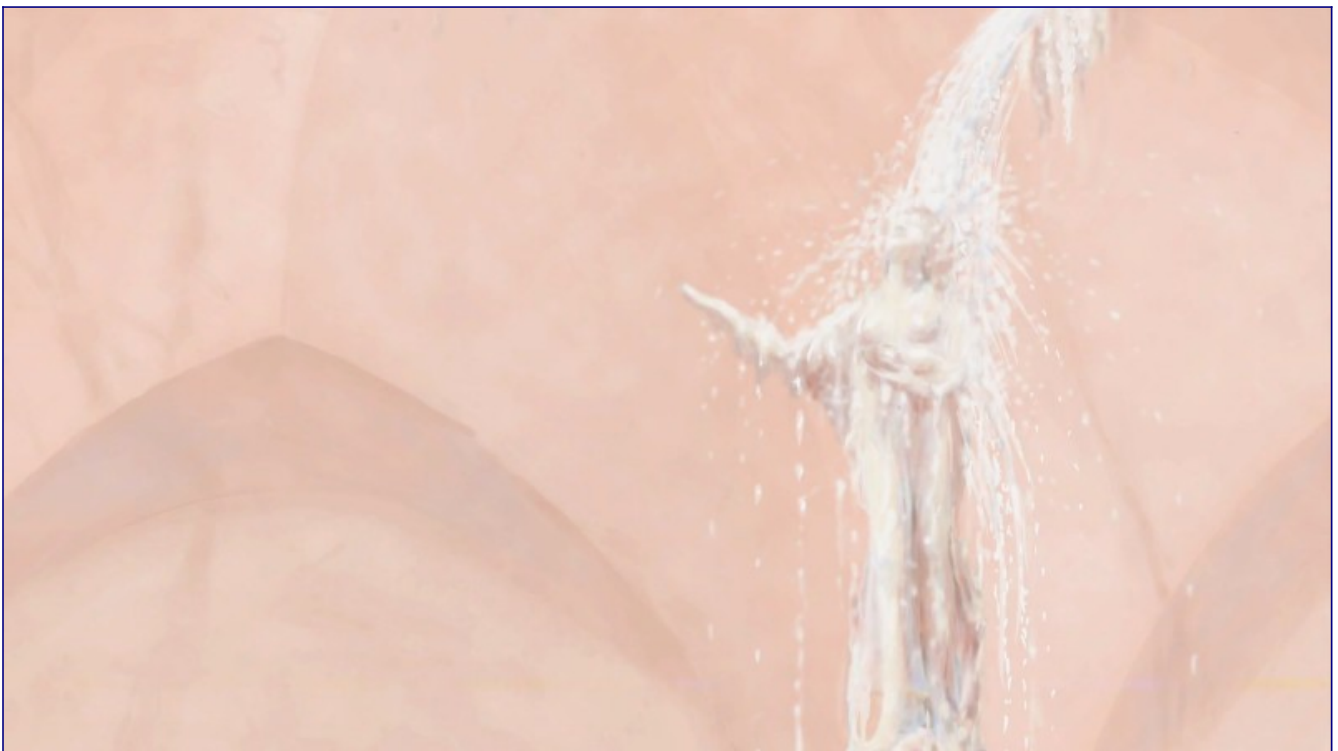

CG: Probably a good three, four feet wide. And there was water pouring out of it. The water was almost pure milk-white. There were also stalactites about, like, this big that were building underneath the little port.

DW: Okay.

CG: And they were off white. And they were falling onto-- the water was falling onto the back of a statue that was a woman-- I guess, a goddess of some sort, that was holding something in her arm-- I couldn't tell what it was-- and had her hand out like this. And she was--

DW: Did she have a hairstyle? Did she have her hair done a certain way?

CG: Her hair was up, kind of stylized up. But she was completely encrusted in, like, mineral deposits like calcium-- almost like calcium deposits.

DW: Was it like a life size human effigy?

CG: It was life size, yes. The water filled a pool up really-- she was up kind of high.



CG: There was stone that came around in a circle, and then a kind of a cut in the stone, and then the water was flowing out, and then down into a larger pool. And then the larger pool was about this high off the ground and was large and wide.

DW: So this dais that she's on must be raised up pretty high, then.

CG: Yes. At that point, the guy turned around-- the Inner Earth guy that was with Gonzales and I but was staying several paces back, turned and walked outside the room and stood outside the room. And Gonzales told me to take off my clothes and put them over on a pillar next to his. And that's when he really told me much more about their Venus worship. They're real big about their cleansing ceremonies.

DW: What is the cleansing ceremony?

CG: Before you enter into certain temples, you have to wear proper clothing and you have to cleanse your body in this-- in certain pools.

DW: So is it similar to the rite of baptism or something?

CG: It's cleansing yourself before you go into a holy place.

DW: OK. Similar to people saying that you've gotta take your shoes off.

CG: Yeah, except--

DW: You had to take everything off.

CG: I had to take everything off. And I was already cold. And it was already a little breezy in that room. I was cold already. Not long after I had taken my clothes off and he's kind of snickering a little bit, the woman who had somewhat greeted us when we arrived comes walking in with folded up-- one of the robes, a couple of towels, and the sandals on it. She comes walking in the room.

DW: While you're standing there just like the day you were born.

CG: Yes. And Gonzales sticks one foot behind and slides and steps back. So she has a clear path to me. I just went [SIGH]. And I was not pleased. But she walked right up to me. She handed it-- handed me the pile of linens and went like this, and turned and nodded at Gonzales, and turned around left the room. But yeah, Gonzales guided me through the cleaning in the pool and using one rag for one part of your body, one towel for the other.

DW: OK. So you're now in the robe. Did other people show up at the room once you'd gotten the robe on?

CG: Yes. We exit the room. We are then brought down the hall, which starts to slope down the hall. And it starts to curve to the right and going down and down as it curves to the right. Then it starts to open up. The ceiling starts to open up. And it comes to a room that is probably getting around 90 feet tall, like that other room.

DW: Okay.

CG: But it's a giant-- like a rectangle, kind of. It was very big. And then there was a large door, and we all stopped and were obviously waiting.

And that was-- we were obviously getting ready to go down to the big meeting. We were standing around in that room just briefly, and that's when I was looking around thinking to myself about the light. And the woman that greeted us and that walked in and carried the items to me, turned to me and with a very strange accent in English said, the light is created by frequency. And I was kind of shocked that she spoke to me.

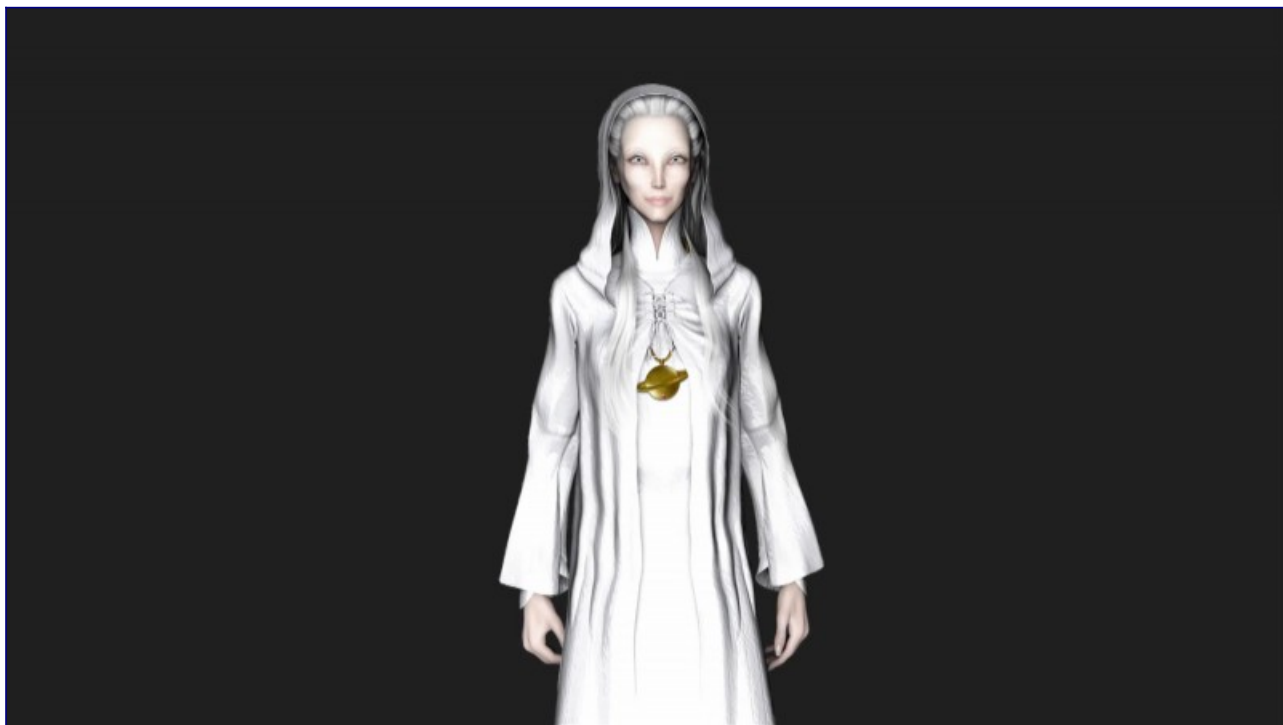

CG: And before I got a chance to say anything, another woman came walking in wearing the same symbol that she wears, the Saturn symbol, and looked at each of us.



CG: And for some reason, I just knew, and all of us, everybody at once, we all put our hoods on and walked down a half-- like, semicircle kind of stairs that were cut into the rock-- just like everything else, out of the granite.

And then we were down on the next floor, and then there was another room. And inside that room were all of these different groups, who we were there to meet, and that was the meeting hall.

DW: Is this is also a very large room with a high ceiling and the domed roof?

CG: It was kind of a medium sized room. There weren't a whole lot of people in. There was approximately three people for every group, plus Gonzales and I, so--

DW: OK.

CG: There were seven groups.

DW: Was there something to sit on in this room?

CG: Yes.

DW: What did it look like? What did you sit on?

CG: They were just-- not really pews because there was no back to it. But stone benches.

DW: OK. That makes sense.

CG: Where several people would sit.

And there was-- this was not a semicircle, but kind of like a oval-- not a full oval room because it flattened where you walked in. The door where you walked in, it was a flat wall, and then there was kind of an oval. The room was kind of an oval, and the ceiling was domed.

And there were the-- there were people standing and people sitting on the pew kind of benches. And up at the front was a group of people sitting around a stone table. And we were walked up towards the front, and when I got up to the front, I could see on the stone table, it had some carvings on it, I don't-- I couldn't make out what they were, but I saw the gold star and the red star, eight pointed stars on the table.

Gonzales and I sat down, and that's when I started seeing all the different groups sitting around the table and in the room with all the different symbols. There was a silver star.



CG: There was a stylized swastika.



CG: There was a horseshoe or omega symbol with a eight pointed gold star in it.



CG: There were three different types of the Saturn symbol that I've described in detail.





DW: Right, with the jewels.

CG: And then there was the one that looks kind of like an hourglass, or it could be a symbol of Orion. I'm not really sure.



DW: But it's like triangles.

CG: Right. It's like two triangles meeting together.

DW: And each of these amulets represent one of the seven major--

CG: Groups.

DW: --differentiations of groups down there?

CG: That was the symbol of each group that was present. And when we walked in, each of the different groups had their amulets, and they were tapping and doing like this on their amulets, and there were these little holograms coming off. So these were a technology and not just their-- a piece of jewelry or symbols.

DW: And that goes back to what this insider once told me, the more technology you have, the less technology you need. Right? The amulet could potentially do everything they need.

CG: Right. And they're different-- there were different looking groups. I briefly described the people already with the Saturn.

DW: Now, a swastika. Were these folks Nazis? Were they--

CG: They had nothing to do with anything Nazi.

And there were different looking groups. There was an African looking group that had bronze skin that were stocky. Not real tall, but about the same height, about the six foot height. There was sort of an Asian looking group, but their body type wouldn't match quite what you would picture on the surface.

CG: And people that looked like from India with a very pale blue skin color, almost like you see a vein under your skin, pale blue.



CG: And there was a shorter, Mediterranean looking group.



CG: And then there was a group-- the group that wore the omega symbol-- that looked very much like they could walk among us on the surface.

DW: So you basically just described some variation of all the major races that are on earth.

CG: Right.

DW: OK.

CG: And they were all coming together to meet, to discuss all of the events that were going on that had pretty much caused them to form this council. There what had been a lot of battles and attacks and a lot of things going on underground that were very troubling to them that had caused casualties among their people.

So they're very much purists of their culture and genetics. The omega group mentioned that they were worshippers of Venus, and they mentioned a couple times the Prince of Venus, the Morning Star.

DW: The eight pointed star apparently is a symbol of Venus.

CG: OK. And there might be other meanings for it as well. Because there was a gold one and a red one. I have not had all these symbols deciphered for me, I don't know what they mean. So--

DW: Gonzales ends up speaking at some point. You said that was a pretty big part of it.

CG: Right. They had their conversation. They were asked to speak in English for their guests. That really didn't happen much. They started speaking this what Gonzales whispered to me was a pre-Akkadian, pre-Ancient Sumerian language that they were speaking. And then there was another language that was-- that they were kind of all speaking around each other. Speaking some English, as they would realize. And we were able-- it was pretty confusing, but we were able to pick up the gist of what was going on.

They were talking about the surface population becoming more of a threat to them with their advanced weapons, the skirmishes that they'd been having with other subterranean groups, non-human groups. They were also discussing the return of what they called the Guardians, and we'll get into that more later. And a couple other things, bits and pieces we were picking up.

And when they were done, the guy from the group with the omega symbol and the star motioned to Gonzales and asked him to deliver his message.



CG: And we could feel all the other groups there didn't really seem to like them or feel comfortable with them. It was the only group that was all men. All the other groups were either two or one woman in the group.

DW: You said in the writeup that him throwing it to Gonzales was a breach in the normal protocol.

CG: Right. So Gonzales stood up and looked over--

DW: What was the normal protocol?

CG: The host of the area we were at was supposed to invite.

DW: So he would ask the host to ask Gonzales, but not go directly?

CG: Right. He basically just--

DW: So he's just being arrogant?

CG: Right. So Gonzales looked to the proper person. They nodded. And he got up, and he delivered his typical short but to the point message that he appreciated some of them visiting one of our bases out in the Kuiper Belt at great personal risk to themselves in previous weeks.

DW: This is an Alliance space program base?

CG: Right. And that we had to start working together more and really had to stop any type of deception, to be open and honest with each other. And that in the future they wanted them to quit deceiving people on the surface, telling them that they were ETs and other types of beings--

DW: Or gods.

CG: --or gods, which they had done mainly in the past before we were sophisticated. And it was real short. And Gonzales finished and sat down, and they-- immediately the energy went up in the room. They were not real comfortable with what he had said, and they started speaking amongst themselves, past ourselves, motioning at us like this as they were talking.

DW: So what was their counterattack? What did they say in response?

CG: They stood up and basically told us that they had been on the earth for nearly 20 million years, that they were the original humans that developed on the planet, and that over oceans of time there had been major and minor cataclysms that had changed the Earth's tilt, its place in the solar system, its orbit. The earth has been through quite a lot. And through it all, they have lasted.

And they have-- they formed, basically, in the beginning and prior-- this happened through many cycles-- they had moved underground their elites and priestess castes, left the less sophisticated part of their civilization on the surface to fend for itself, and then come back after some time and appeared to those people as gods or elders, and helped kickstart civilization again-- give them agriculture, medicine, help them with language, arts, and all that kind of thing, to get them kickstarted again. And this is something that has happened in cycles over eons and eons of time.

DW: In the aftermath of these conflagrations and cataclysms?

CG: This has happened in cycles and cycles before our accepted time, our history, our accepted history.

DW: Right.

CG: And they decided to allow the people to believe they were gods for what they said was operational security, so the people wouldn't be a threat to them. And this continued on for eons.

And they stated that there were other planets in our solar system that were inhabited by similar types of life forms.

DW: Humans?

CG: Human-like life forms. But they were also going through cataclysms, but they were much more aggressive and warlike. And they were destroying their worlds and their societies, and eventually they caused some major problems, and other races that came into our solar system started to move them to the earth as refugees. And once they were moved to the earth as refugees, they started their aggressiveness here and started to take over the surface of the planet and mixed their genetics with each other and the surface humans-- original humans-- to create a mixed breed human group that is what they consider us on the surface.

DW: I can see why you think this is going to be controversial.

CG: Yeah. So-- and they were-- they scolded us and said they knew that the Secret Space Program had been involved in some atrocities, and they were withholding judgment on us, and they expect us to do the same because we have very little understanding of our own existence, let alone theirs.

DW: So it's almost like an Aryan ideology kind of thing. Like, they're the pure bloodline and we're the dirty, mixed bloodline that has all this aggressive genetics in it that they don't want to get dirtied by.

CG: Right, right.

DW: So that's certainly not going to go well with Gonzales, I'm sure.

CG: Oh, it didn't go with me either.

DW: Yeah.

CG: I was-- when all of this was being said, I was sitting down next to Gonzales. And when they were just about done, he leaned over and he said, that went well, didn't it? And I was still just-- had all this going through my head, so I didn't even really here as it was all coming to a close-- the meeting was coming to a close.

Everyone started standing up and put their hoods on, and so I did the same. And we're standing there and everyone's forming a line and shuffling to go back out the way we came. So everyone's quiet. We shuffle our way all the way back up, back through the corridor that goes to the cleansing room.

CG: And I'm wondering if we're about to go through a more large public cleansing, but everyone's going past. I see everyone's going past the cleansing room, and I'm seeing flashes down off in the big room that I appeared in originally.

DW: Like they're portalling out or something.

CG: Right.

And I'm still walking, and I feel a tap on my left arm. And I took a couple more steps and I looked back, and Gonzales is standing back like this with two of the females from the host clan that was there. And I quickly stepped next to him, and I found out that they had a personal request for me.

The woman that had greeted us, that I mentioned before with the white hair, had found out about a experience I had in the MILAB program when I was a youth, and that had something to do with this favor. And I said I would hear her out. And she said walk with me, and she started walking. Gonzales and the other lady walked about five or so paces behind us.



I expected her to start talking. She was totally quiet. We walked completely through the giant room where the portalling happened, walked across into the next tunnel, corridor. There were doorways all up and down that had a light barrier across them, a white light barrier on the doorway. And--

DW: You couldn't see through it.

CG: No. And we went a ways, and she touched her amulet, and the light went down, and I could see in the room. And it looked like a real simple lounge or-- I don't think it was like a bed-- it seemed like a lounge kind of room. She walked in and said come with me. And I looked at Gonzales and he was like, you know. He kind of had that look on his face. And I walked in. She closed the barrier.

And I was feeling very anxious. I'm kind of an introvert, anyway, so being in the room with a lady I don't know, and-- I just didn't know what to expect. And then she interfaced with me mentally and told me to relax.

DW: Now the other people were speaking with their mouths most the time?

CG: Right. There was interfacing going on one to one, but when they're communicating, like, more than one on one, they were speaking.

To bring a long story short, she told me that she knew of a place that I had been brought in my adolescence, you know, a crystal cave.

DW: Right.

CG: And it was a cave that we were brought into. Beautiful crystals that we were told to try to connect to mentally-- not to touch because we could damage them or they could damage us-- that the crystals were living beings, and--

DW: You had said they glowed?

CG: Well, once you started trying-- not until you try to interface with them. And if-- and I was able to successfully interface. Other kids were in the chamber, the cave, and they had a aura around them, a pink, purple aura. They had different auras.

And I sent her a quick mental picture of it. And she just beamed with happiness and tears welled up in--

DW: Why would you be able to access something that she and her people couldn't have accessed on their own?

CG: She explained to me that there was a group that had hundreds of years ago taken over that area. And it was a-- basically, the word in their language-- I can't remember it right now-- it means feathered serpent. But it was-- she sent me mental pictures-- it was an image of this raptor group.



DW: Right.

CG: And I got a better image. I got to see how they move, instead of just what I'd seen on the glass--

DW: These very creepy reptilian bird-like species you described that'll eat human beings.

CG: Right.

DW: Very nasty.

CG: They had control of the area. And without getting too detailed, they require a flesh sacrifice from their allies on the surface for access to certain areas below.

DW: Which I'm sure the Cabal have no trouble providing them with.

CG: Right.

So she said, would you be willing to share that full experience with me? I didn't know what that meant. I asked her. She told me about the process, that we would hold hands. She would open my mind to her.

And I let her know that I was not comfortable with that for a number of reasons-- security reasons, personal sovereignty reasons.

She started giving the hard sell. It was important. She was saying that basically we don't really have that much more to offer them, that this was really important to her people. I was kind of pacing around, thinking about how this--

DW: What did they think was going to be in the crystal? What was so important to them about the crystal?

CG: Don't know at that point. I asked her if I could speak to Gonzales. She-- I'm abbreviating this. It's all in the report. She quickly went to the door, released the field, left. He came in. And he was like, what's going on in here? I told him what was going on.

He said that he understood my concerns, that unless there was Sphere Being Alliance or information that happened between Tear-Eir and I that I didn't want her to know about that there was nothing to worry about because the SSP Council-- Alliance Council-- hadn't shared anything with me that-- they basically hadn't trusted me with a lot of different information that was actionable data to worry about. So he said that I didn't work for him. He couldn't order me to do it. But it might be a bidirectional exchange of information.

DW: So since you were already on the skids with them before, and you'd had this aggressiveness and yelling, you were worried that if you just arbitrarily took her offer that potentially intel could be extracted out of you that could get you in even more trouble or get you booted out of the Alliance or something like that.

CG: Or they wouldn't give me data in the future. They would cut me off from intel, which it sounds like they already had done quite a bit. Or I was concerned about personal sovereignty type-- I didn't know what could happen.

DW: Exactly.

CG: So--

DW: So he gives you the go-ahead, basically?

CG: Yeah. I said all right, go ahead. Tell her to come back in.

And she came in, and she came but just went and just looked right at me in the eyes, like it just like--

DW: Like she's on the edge of her seat.

CG: Yeah. And I told her I would do it, and she was just-- started buzzing around. And she went over to a wall. There was nothing there but a wall. She walks over to a wall, and then she turns around and she has a goblet, a crystal goblet, in her hand. There wasn't a door or anything there, but she has a crystal goblet in her hand with this amber liquid.

DW: Uh-oh.

CG: Yeah. And she walks over to me and offers it to me. And I look at it. I ask her what it is, and she said it's the Elixir of Essos. And she explains that it's basically a wine that's made out of a rare flower that grows beneath the ground. And I told her, I wasn't--

DW: So you could be tripping brains if you drink this thing.

CG: I didn't know. I told her I wasn't comfortable taking it, drinking it. Is it a necessary step? And she said no, it's customary, basically. So--

DW: Yeah, I wouldn't have drank it.

CG: She took it, and she took several drinks of it. And her-- immediately, she changed. I don't know if it was inebriation, but she immediately was just different, changed, relaxed. And she sat the drink down.

She had me sit down in a chair that looked like if you have an egg and it was cut this way. She had me sit down, and it was barely off the floor, hovering.

DW: It hovered?

CG: Yeah. It was not on the floor. And she, like, with two fingers guided another one of the chairs right in front of me. Then she sat down just right across from me, and--



DW: Closer than we are now?

CG: Oh, yeah. Yeah. Just got real close and asked for my hands. I gave her my hands. She turned my hands up like this and put her hands like this.



DW: So this kind of deal.

CG: Yeah. Like this.

DW: On top of her knees?

CG: On top of both of our knees, like this. And we were leaning like this.



CG: And her hands were bony, and her skin was very warm. There was-- body temperature was different. And she looked at me in the eyes, and she said I needed to relax, and I needed to open my mind up. And I started to use some of my techniques to lower my consciousness a little bit, get relaxed. And there's no way to describe what happened next.

I felt like my light body or astral body was being pulled in her-- towards hers-- and they were just kind of coming together. And I started having-- she was obviously very more advanced than I was mentally. She was honing in on time periods of my life. And when I was getting all these random flashes of what I perceived to be 130 years of time of her life.

And I got flashes of her as a child, as her in priestess training, as her meeting with different people from the surface-- meeting with secret society groups, meeting with different military and groups from different political systems, from Europe and the United States--

DW: Presenting herself as an extraterrestrial?

CG: Presenting herself as an extraterrestrial, with other people with her from her group.

DW: Wow.

CG: And this was through-- I could see the clothes they were wearing. They were-- it was through all these different time periods that she had been meeting with them.

DW: So this is sort of like the life flashes before your eyes thing, except it was, like, her life?

CG: Yeah. It was real random. I couldn't hold onto them. But when she locked on to the memory of mine, of in the cave, I got a memory of her at the same age. It was a memory of her losing someone in some sort of a skirmish or attack, to some insectoid type attack. But she-- then I was pulled back into the experience in the cave, crystal cave. And it was very vivid. We relived it.

Then after it was over, we both sat back and were-- I was just shaking, quivering, and my brain was releasing all these pleasurable endorphins. Nothing in any type of sexual or weird way at all, but it was just-- it was very overwhelming.

And I had-- I've-- since then, I've been very different. I've been just up in my head a lot, thinking, thinking about a lot of stuff. And it's affected me to where I've been a lot more intuitive about things. It's been very weird.

And so we composed ourselves, and we--

DW: She had a similar reaction to you?

CG: Oh. Yeah. She was doing the same thing. We had tears just-- that were just coming down out of our eyes.

DW: Both of you.

CG: Yeah. It was extremely emotional. It's unlike any type of connection I've ever had with another person.

DW: Is this something that any of her people could do, or was it something she specifically trained for as the priestess?

CG: I think that's something that all of their people can do, because when we were done she said that there's going to be some people that are not going to approve of her doing this with a mixed surface person, but there's going to be a lot of other people that are going to be extremely happy with the information she was able to pull from the crystals that I interfaced that I have no conscious-- I don't know what information that was pulled.

DW: Well, you told me they blank slated you. They wiped your memory after you got the crystal data, right?

CG: Right. But--

DW: But she somehow could get it.

CG: Right. But, you know, memories exist on your physical hard drive, but also in your light body in that virtual hard drive as well.

DW: So this is sort of like the Vulcan mind meld.

CG: And that's what I referred it. When I talked to her, I said I will go through with your Vulcan mind meld, kind of as a joke. But it wasn't funny to her.

And then after this, we kind of got our composure together, and we went back out to the hallway where Gonzales and his hostess was waiting. And she was very pleased. And at that point she was basically offering, if we had the time she'd like to give us a tour.

And Gonzales had been wanting a tour of the other places he'd been on, so he just snapped and accepted the offer. And, well, I'm sure that we can go into the very interesting tour I had.

DW: All right. So we got a lot more coming up in the next episode as we continue this fascinating story here on [Cosmic Disclosure](#). I'm your host, [David Wilcock](#), and we thank you for watching.

[Cosmic Disclosure: The Grand Tour of Inner Earth](#)

Season 3, Episode 5

DW: All right, welcome back to "[Cosmic Disclosure](#)." I'm your host, [David Wilcock](#). I'm here with **Corey Goode**. And it is a really fascinating story, something that when he wrote this up, it went nuts on

the internet, right? I mean this, blew out all the records of viewership and user engagement. The type of feedback you've been getting on this was just phenomenal.

CG: Yes

DW: So we had a discussion about this Alliance, and some of the things we zipped through kind of quickly because we wanted to chunk in a lot of narrative into a half an hour. So some of the inevitable questions that are going to come up when people watch the previous episode who haven't read the paper, and we've got to assume that they haven't, would be, for example, you said that these groups have a roughly 20 million year history. Are they all 20 million years old?

CG: The group with the Saturn symbol claimed to be 17 to 18 million years old. And the youngest of the groups-- they said they didn't give a date, but they said a few ice ages previous.

DW: The youngest of the groups. And which one was that?

CG: I thought to myself it was the group that looked most like us, the human.

DW: I see.

CG: I mean, to me that seemed to make sense.

DW: Now, these people were all wearing the robes and sandals?

CG: Yes.

DW: And that's a ceremonial clothing that they all have to wear to be there?

CG: It's not what they would normally wear. It was to wear-- where we were at was a, I guess you would say holy ground, temple complex. And I don't know if that was just for that group, what was their custom, or if that's what they wear whenever they meet at other people's locations.

DW: Did you didn't notice anything specific on these holograms that you said were coming out of the amulets? Like was it-- what was the scenes? Did it look like a heads-up display, or?

CG: Yeah, it looked like some sort of heads up, but I could not-- from my perspective, I couldn't see what it was. I could just see it was light coming up. And they were looking at it, messing with their

pendants. I couldn't see what it was. I guess it's kind of like you have to be right in front of it. You know, viewing from my angle, I couldn't see what it was, other than it was light.

DW: What was the weirdest thing that you saw from this woman's life that surprised you the most when you're getting this flash? Something that really was unexpected?

CG: Well, the fact that she was a virgin, that she was the priestess. She was in a priestess class. She was over 130 years old, and she was well, a virgin-- had not been with a man, or had not been involved in any type of sexual activity in her life.

DW: When the Japanese were contacted by their gods, they described what they called Ame-no-torifune, which they said was bird boat universe, or flying boats from the universe. These people came down, gave them written language, taught them a tea ceremony, taught them to make silk and kimonos. And I'm wondering if you think it's possible that one of these Inner Earth groups-- because the swastika is associated with the Shinto gods as well-- do you think there may be a connection between Shinto and some of these Inner Earth folks?

CG: Most likely. They claim to have done it cycle after cycle after cycle, that they brought these types of technologies to struggling and recovering civilizations time after time after time. And really curtailed that and slowed it down more after these ET races from outside started coming in.

DW: So you have this exchange with this woman. Gonzales must be wondering, what the heck was going on in that room? Because you were in there for a while, right? It didn't happen right away.

CG: Yeah, that's the first thing he said. He said, what's going on in here?

DW: You're with Gonzales. What happens next?

CG: We've been invited to go and take a tour. She's much more relaxed. A lot-- real happy about the experience.

DW: You both had a cigarette.

[LAUGHTER]

CG: She was elated that the experience that I shared with her she was going to be able to share with others. So she was feeling generous, wanting to show us around. And so we walked down the hall, went to a small, domed room and stood in the center. She rubbed and tapped on her dial-- flash of light.

We're in another room-- another big room. This area, the stone is slightly darker. It's a different area. And so we start walking through some different passages and rooms.



DW: The overall look is the same, just that the stone is darker.

CG: Right. And we're working our way. She wants to take us to see their gardens. We came out into-- out kind of like-- we were in the wall of like a cavern coming out, and there is a cavernous area that is so huge. And there are pillars that go all the way up to the ceiling, that I couldn't even begin to estimate how tall the ceiling was.

DW: Wow.

CG: I mean this cavern was the size of a state in Texas. It was absolutely huge. And built into the pillar were some structures that were built into the pillars.

CG: Like where people live?

CG: Where people lived or worked or did something. And they were bigger around than any skyscrapers I've seen, these pillars. And there were all these--

DW: Did you feel like vertigo-- like you're like, whoa, you can't even stand up?

CG: When you looked up, there was a-- not really a vertigo feeling, but a forced perspective feeling of-- did not expect to come out into such a large area.

DW: Was it the same type of diffuse lighting, where it's just bright everywhere, and--

CG: Not up high. Down low there was-- the lighting was everywhere.

DW: OK.

CG: But there were people walking all around. We got to see just this one little area of this big city. And there were people walking around in one-piece clothing, different age people-- young people, older people.

DW: One piece like jumpsuits?

CG: Yeah, kind of jumpsuits, one-piece suits.

DW: And what were the colors?

CG: They were red, green-- I mean, all these different colors. And they were just walking about doing their business.

DW: Did this represent all the different types of people in the Inner Earth Alliance, or was this just one of the groups?

CG: This is just her-- this is one of her cities of her group.

DW: So the people with the Saturn amulet.

CG: Right

DW: OK.

CG: And those people were not wearing amulets that were walking around. And as we were walking along, still staying close to the cavern wall, we've seen a very small part of the city.



CG: There were some buildings that were built up in domes-- some in kind of like oval domes that seemed to emanate light from themselves, kind of a white light. A lot of the buildings that were built out of the stone, like they were just molded out of the stone.



DW: Right.

CG: And we were looking around, and Gonzales bumped me again, and I looked up and there were all these craft flying around on the inside.

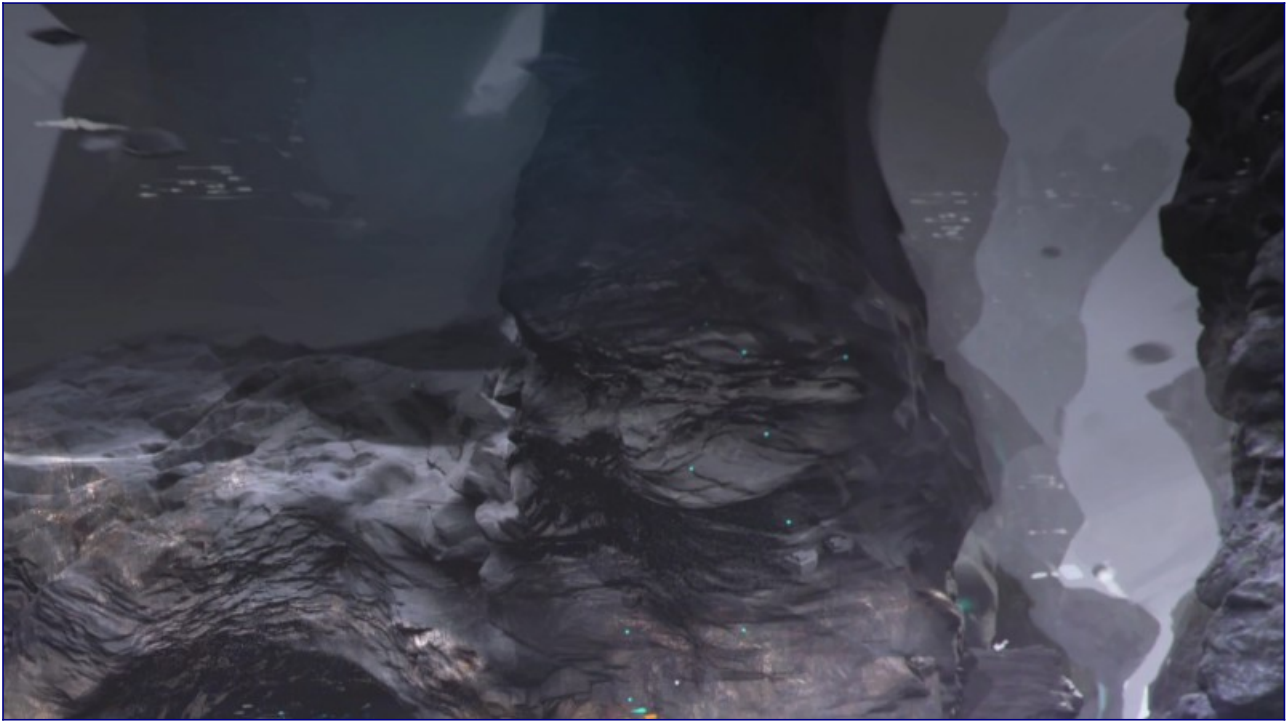

CG: And it looked like a 1950s movie. There were classic UFO saucer-shaped saucers flying around and large cigars and egg-- almost perfect egg shaped.



DW: So these craft are zipping around inside this huge, huge room.

CG: Not only that, they're flying through the side of the cavern at full speed. Not slowing down, flying right through the rock, right through the walls. And I mean, as if they're water or air. Just flying right through them.

DW: So clearly they can go out of phase with the rock and just zip through it.

CG: So we got to see just very briefly, we got to see this as she walked us down into-- back and towards the wall of the cavern.

DW: About how many craft were airborne at any one time that you could see?

CG: There were over 30.

DW: Wow.

CG: I don't-- there were a bunch. She brought us down into what were obviously like more service-type corridors. They weren't quite like the corridors before. They were a little bit more narrow. They were I guess kind of like city works or service corridors.

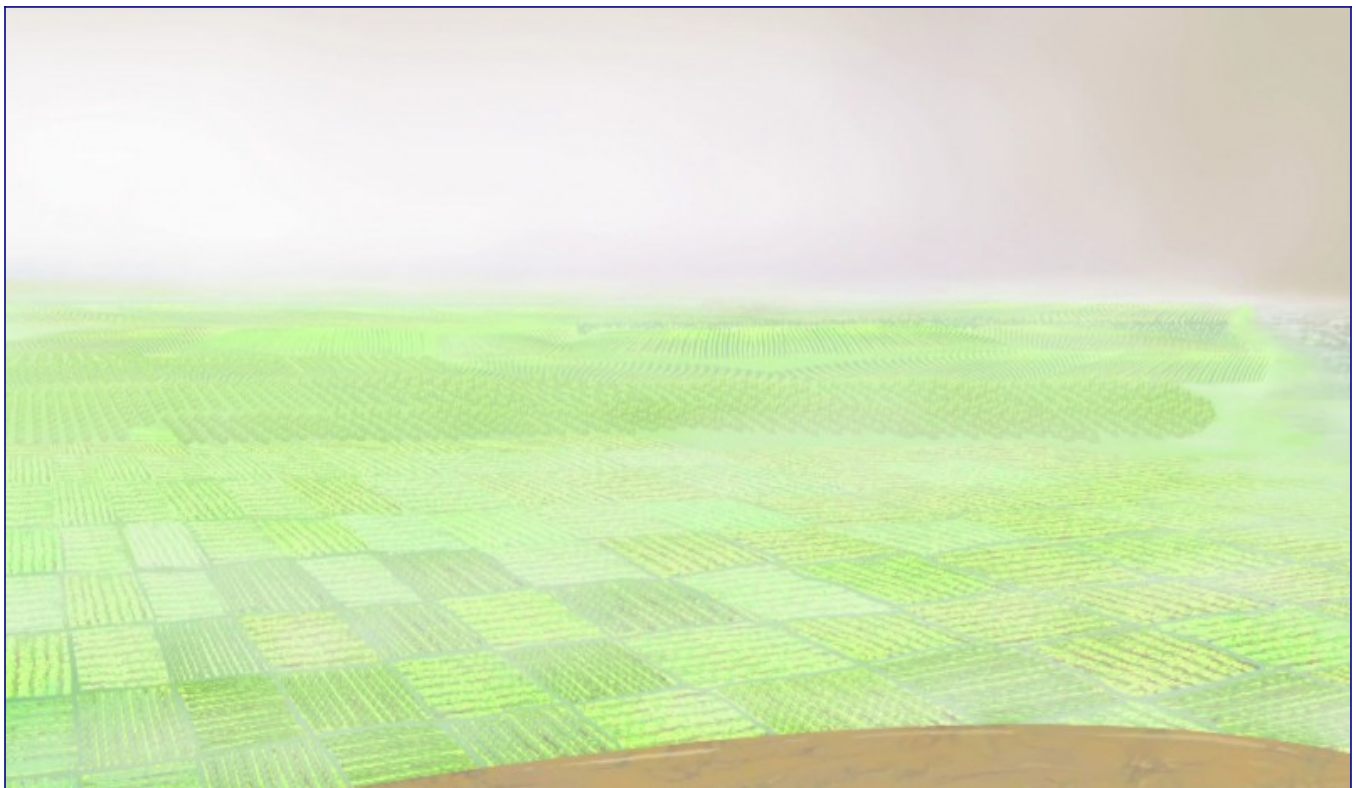

She brought us to this area to where we walk out and we're out on somewhat of a ledge. And you walk out the door, and then there's like a staging kind of platform. And then you walk to the edge of the staging platform. There's no rails. And then there's like a cliff down, and then you're looking out into this huge cavern area.

CG: And there are segmented crops and vineyards as far as you can see. And I couldn't really make out exactly what was what, but you could just see segmented-off crops, trees off in the distance, vineyard areas, and there was water that was rushing in and then coming out on another side that you could hear.

DW: Like a hydroponic system.

CG: It was a hydroponic system. And she said the light-- the full-spectrum light is produced in the same way described before.

DW: Did you ever get an estimate of how many people were in her population? Is it like 30 million, or--

CG: I don't know how many people. But that was--

DW: But that's enough food for a lot of people.

CG: It was-- yes.

DW: I mean, we can grow most of the food for America in California, and you're saying that this one room that you were in was as big as a state.

CG: This-- yeah, the garden area was--

DW: Just colossal.

CG: Like hectare.

DW: Wow.

CG: I mean, it's huge. And she pulled up a bunch of different types of rocks and crystals that were crushed up. And she said, this is the medium that the roots grow in. And she said the water has natural minerals in it, and we have a-- we recycle everything. And on the other side of the wall, where the water flows through, it flows through some composting and other materials to give it nutrients. It flows

through the rocks, and then the rocks filter the water, and the water returns back to its source clean.

And the nutrients go to the plants, and the crystals and the type of light create a very high-yield and high-vibratory food for them. And when she said high vibratory, she kind of looked at me and smiled because she knew that I had-- I guess she knew I'd been talking about high-vibratory food after our little mind meld thing.

DW: OK, so you go through a few places, and where's the next major thing that you end up going to?

CG: We exit out of this into the park, and it had a larger opening doorway that the four of us walked out into. And there are-- we could smell all kinds of pollens, and just so many smells. Sensory overload of-- and then sounds of-- I mean, it was just sensory overload. And we walked in--

DW: Was it warmer?

CG: Yeah, there was-- when you walked in there was an atmospheric change, like atmospheric pressure change. And there was an artificial ecosystem in this giant cavern that was as big if not bigger than the garden.

DW: Wow.

CG: And there were stairs that went up almost all the way to the very top that you could walk up. And the trees were so tall that we had to climb up the stairs to be able to see over the trees.

DW: You said before that the natural caverns inside the Earth only had vegetation that went up to like knee height. So how are they getting trees down in the Earth?

CG: This is-- they terraformed. They created this environment.

DW: Wow.

CG: And they created-- I mean, it had a pale blue sky.

DW: Really?

CG: And not full clouds, but misty kind of clouds.

DW: These trees are bigger than the redwoods in Northern California?

CG: I would assume so. I haven't seen a redwood since I was a kid.

DW: Well, they're pretty darn big.

CG: But we had to climb really, really tall up the stairs. And we were looking out over all these trees. We were seeing some birds flying around with long tail feathers-- blue, red, and yellow. Very beautiful birds. She said, don't be alarmed.



CG: There are some animals from our era that we've preserved down here. They're not dangerous in their current stage of development. She didn't say anything other than that.

DW: Did these birds look like anything we would normally see on Earth?

CG: Not too terribly unusual. I mean, there could be birds like that. I'm not that well traveled on the surface of the Earth. There could be birds like that that I haven't seen.

DW: So they could look tropical, with the colors you described?

CG: Yeah, I guess they could be tropical. But I haven't seen birds like that.

DW: OK.

CG: But there weren't like pterodactyls or anything like that.

DW: OK.

CG: So when we were up to where we could see over the trees and towards what I would think is the middle, because we couldn't see all the way because of the mist, there was a giant obelisk that went up that was stone and weathered. And then up even higher above it, up at the top of the cavern, was a huge plasma ball that I guess was supposed to represent the sun or an imitation of the sun. And it was a part of this, I guess, fake ecosystem that they created.



DW: Now, let's just stop right there because this is one of the very bizarre things. You had this experience, you said, the beginning of September. I can prove that I sent the design, I got a sudden intuitive flash of what the cover of my new book, "[The Ascension Mysteries](#)," is supposed to look like, and I asked for an obelisk that had a star type of light source at the top. And I just showed it to you today, and you darn near fell over backwards.

CG: Yeah, and there was Saturn in the background.

DW: And Saturn in the background, like the amulet.

CG: I don't know how to explain that.

DW: And I was having what appears to be the mind of this priestess trying to contact me this morning telepathically as I was waking up, and she kept saying, "do you recognize me, do you recognize me?" So this is very much an evolving story. It makes me wonder if she has been working on us already. This is very bizarre. When you told me that-- when I read that part of your story, and then I'm looking at the book cover, I'm going, wow, OK, this is nuts.

CG: People will have a hard time not believing we collaborated together to make this happen. I mean, I couldn't-- it's strange, but--

DW: So what's this obelisk for?

CG: I don't know.

DW: It's the biggest thing there?

CG: Yeah, it was the biggest thing, right in the middle. And it looked worn, like weather worn.

DW: Wow.

CG: From what I could see. It was way off. And we stayed real close--

DW: Was that like the star, like the sun, like the light source of the whole place?

CG: It was below the light source.

DW: Oh.

CG: So we walked back down the stairs and started walking towards the tree line, having conversations. And we could hear in the background, we heard at one point some elephant kind of sounds. And we were hearing different things. But we weren't seeing them.

DW: I'm dying to know, were there anything in this area besides trees? Did they have paths that were made out? Did they have little buildings? Did it look like Stonehenge or anything like that?

CG: No. It was--

DW: Just all nature preserve.

CG: All nature.

DW: OK.

CG: And I started walking with my hostess towards a clearing. So I wanted to see something. I wanted to see one of these animals. And we stopped, and we were talking, and Gonzales was talking with a girl, and they were talking about-- Gonzales was talking about, we'd love to have things on the surface this peaceful and have everybody openly working together, and talking about a great future for humanity. And the lady he was with said kind of a derogatory statement, that she didn't see that being a possibility for the surface, the mixed surface race, that we had--

DW: With our aggressive Draco genes.

CG: Or not just the Draco genes, the mixed genes of the beings from the other planets from our solar system.

DW: The survivors.

CG: Right, that mixed. But she said that she thought it would take forever. This is something that would not occur very quickly. And they started conversating about it.

And I started talking with the hostess, and I said, Gonzales said that the language y'all speak is pre-Akkadian or Sumerian. Do y'all have anything to do with the Sumerians? And she told me yes. She said very much so. She said after one of the minor cataclysms-- and she talked about many different minor cataclysms again, and what the Earth had been through, that they had brought agriculture and different things to the Sumerians, and had brought them written language and that kind of thing. And then I started bringing up philosophical questions and mentioned that on the surface, more and more people are believing in ancient aliens and genetic manipulation and us being created by the Anunnaki, and you know, was starting to lead questions with her that way. And that's when she said, maybe our next stop should be the library. And--

DW: Real quick though, these cataclysms, I want to point something out, because I've done some new research, which I did not know you were having this experience while this was going on. I've been led to study the etymology of the word cataclysm, and cataclismos, which is Greek, and it means destruction by water. But there's another word, conflagration, which means destruction by fire.

And there's a very widespread, as I've now discovered-- it's going to be in the new book-- a very

widespread ancient tradition through Greek and Roman, Stoicism, Akkadian, Babylonian, Sumerian, where they all say that at the end of the big cycle, there's a conflagration. There's a solar flash. And so they differentiate by fire or by water. Now, these people had to have something to do with that message coming in. So I'm wondering if they ever got into the idea of a flash, of a solar flash, as one of the seeds of these catastrophic changes?

CG: We spent a lot of time in the library talking about a lot of very in-depth things like this.

DW: OK, this is the part I haven't heard yet.

CG: Yeah.

DW: Good.

CG: A lot of very, very controversial things for most people came up. But once she suggested this, about this time we heard the sound of a very loud, large cat.

DW: Oh, my god.

CG: That wasn't that far away, and you could feel it in your chest. It was very deep, loud.

DW: And we know that sabertooth tigers were all over the Earth up until 50,000 years ago.

CG: Yeah. So, we didn't get to see it, but--

DW: They said they were all safe, right? Like, the animals are not going to attack you?

CG: Well, yeah, they said they were not dangerous in their current state of development, whatever that means.

DW: I don't know if that would make me feel all that comfortable if I heard that.

CG: It didn't make me feel all that comfortable. But we were already talking about the library, and we started to head back towards the big entrance. And after the cat sound, we looked back, and Gonzales was still in the same area with the lady he was talking to. And they had looked in the direction of the cat. And he was looking back and saw now that we were headed back up towards the door, and then they headed our direction.

DW: So is this like the typical creepy lion roar?

[ROAR]

CG: Yeah, it was--

DW: Wow, OK. And you felt it in your chest? It was that close?

CG: Well, it was that powerful, that deep. It, like, rattled your insides.

DW: Did you see any other beasts? Elephants or anything like that?

CG: No, I didn't see any other-- anything other than the birds and the plants.

DW: OK.

CG: We were headed out. She seemed to know that Gonzales already had a-- it seemed prearranged situation to where in one of their craft, they were going to fly him back to one of the bases.

DW: Okay.

CG: And she said, if it was okay, she wanted to take me to the library. And Gonzales was visibly disappointed. And he wanted to talk to me before he left. And he mentioned to me, he said, this isn't going to go over well. He goes, I wish we would have went to the library first. He goes, I really would like to have been there. But when I report back to the council, Secret Space Program council, you know, I'll report that you got to go to the library. Just make sure you remember as much as possible, and give me a briefing within 48 hours, so you don't forget what you've learned.

DW: I thought Gonzales, from what you described, and I don't know how much we really covered this here, but you said that he had been through several meetings with these people already.

CG: He'd never gotten a tour.

DW: So he was seeing all this for the first time too.

CG: Yes. He jumped--

DW: What did he look-- what was the look on his face as he's seeing all these things, the gardens and the saucers flying through the air?

CG: Well, he was looking like he was in awe a couple times, like with the saucer thing, but I really wasn't watching him that closely. I was looking around. But I imagine he was taking it in as much as I was.

And I had forgotten a lot of the protocols about remember how many paces this way, you know-- you're supposed to, when you go into a new environment, you're supposed to mentally map it out and that kind of thing. I wasn't doing any of that. And I imagine he probably was. He had a lot more going on up here tactically, strategically.

DW: You've seen a lot of heavy stuff that most people would probably do anything to see. You've seen bases on other planets. You've been inside spacecraft of very advanced faster-than-light travel, portal travel. Is there anything else that you've ever seen that was as amazing as what this stuff looked like?

CG: No. This was a truly amazing experience in a positive, awe-inspiring kind of way.

DW: Very interesting indeed. So what was the reason why Gonzales was so concerned about this library? Did he know there was something in there that was very valuable?

CG: Intel. Library, information, intelligence. And he got to see a garden and a park.

[LAUGHTER]

So he wanted to see the intelligence. And he was about to be walked to one of their vessels and flown to a base, and I was about to be walked to see and have a discussion in the library.

DW: All right. Well, coming up next time here on "[Cosmic Disclosure](#)," you're going to be getting my authentic reactions, stuff I've never heard him say before, the journey to the library. And we thank you for watching. We'll see you next time.

[Cosmic Disclosure: Inner Earth – The Library](#)

Season 3, Episode 6

DW: Are you ready? This is "[Cosmic Disclosure](#)." I'm your host, **[David Wilcock](#)**. I'm here with **Corey Goode**. And for the first time ever in the history of this show, I'm going to be getting information that I am dying to know about from you, in real time, on camera, stuff that's very significant for both of our

lives.

Because you've gotten pulled into this, and I'm obviously on this journey with you. But up until now, I have no conscious recollection of having any experiences off-planet or in the planet, even though maybe I have had them. If that is happening, I'm being blank-slated. I'm not remembering anything yet.

So there's something going on here. These people are very intimately connected to us. And this information is eventually going to bridge the gap and lead to a family reunion, if they can get past the idea that we're mixed-blood and inferior to them.

But the other thing that I just wanted to point out is they're acting as if we're not going to have such a sudden leap. But if you read the Law of One, which I've scientifically validated, it very clearly says that the 25,000-year cycles of third density-- there's three of them-- that we're at the end of all three, that there was a very massive sudden quantum upgrade of the human condition at the end of that cycle. They call it a quantum leap. So the idea that it's going to take generations and generations for us to grow up isn't necessarily true.

CG: Everybody has their own belief systems. And that's one of the things that we need to put into perspective for this part of the discussion. Because a lot of this information is going to be difficult for a lot of people's established belief systems.

And I took time out--

DW: "Difficult."

CG: Yes. I took time out to write an article about keeping your reality bubble permeable. Just because after this meeting-- because my brain has been so overwhelmed with all of this information. And it's-- people will need to sit back, buckle up your seat belts, open up your minds a little bit. Everything that you're certain that you know, just be ready to open your mind to other possibilities.

DW: Some people are going to believe what you're saying. Other people are just going to go right on thinking whatever they already thought is true, so.

CG: Right.

DW: You don't need to be too worried.

CG: OK.

DW: But it is going to-- I know you've been preparing us for this. It's going to rattle people. So I'm really interested. So let's not play around with the amulet. Let's just--

CG: Get on with it.

DW: Get into that library. What happens next? Gonzales is pissed.

CG: Yes.

DW: He can't-- he can't believe--

CG: He's missing out on the library.

DW: That they've chosen you and he doesn't get to go in himself.

CG: Well, and I think the library thing happened just because the priestess and I connected, and I got assigned to the conversation. And things just led that way. I don't think they just said, we're going to pick **Corey** and send Gonzales on his way.

DW: So, what happens to Gonzales? How does he end up leaving?

CG: We leave together. So you hear the lion, or whatever it is, the cat, roaring.

DW: Yeah. We leave, and then we go through another one of the kind of small, little corridor areas, out-of-the-way corridor areas. We come out into another domed room that's kind of, I guess, a portal-type room. We're all four standing there. Sorry, tapping happens on the little amulets. Flash of light.

And now it's just the priestess and myself. And we're now in a completely different environment, to where it is white, polished stone, and beautiful.

DW: Like white marble?

CG: Like white marble.

DW: Were there marblings in the stone?

CG: Yes.

DW: Cool.

CG: It was beautiful.

DW: Wow. How big?

CG: And all one piece. It was not a super large room. It was about the same size of the smaller portal rooms. And I looked straight up to see a gold bar come out of the ceiling with a hand and a crystal ball inside the hand.

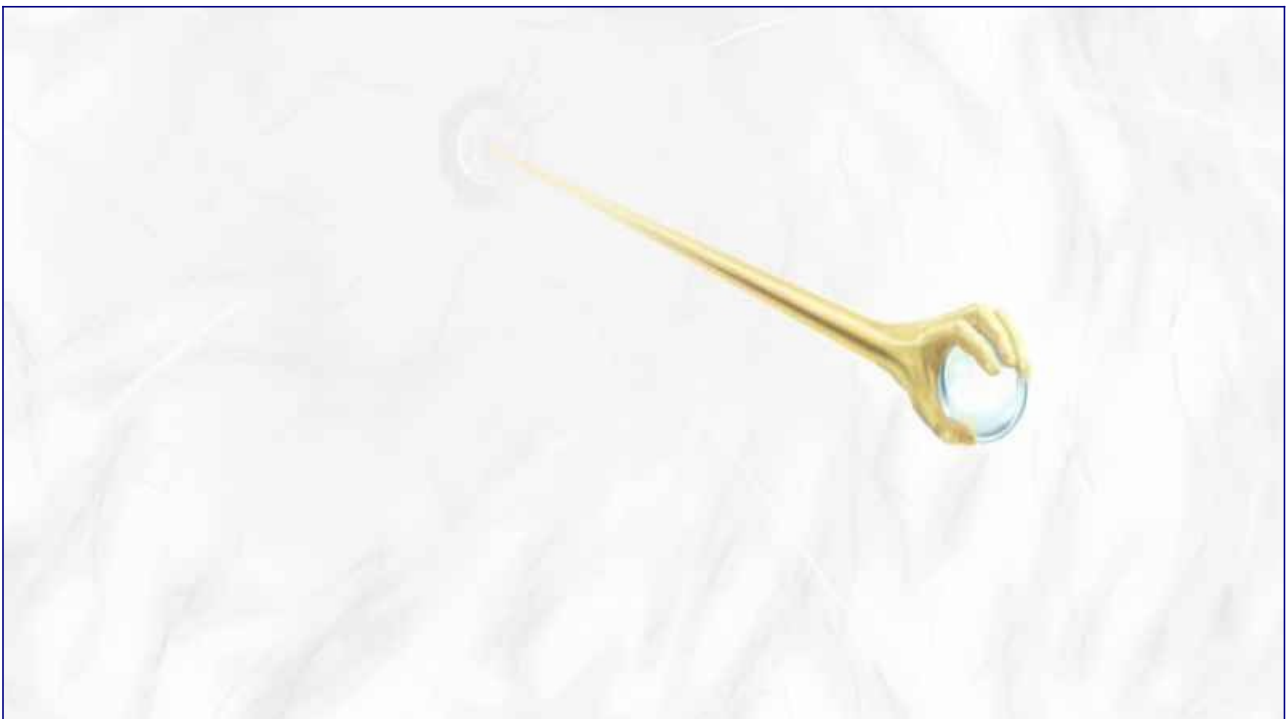

DW: Was there any other stuff like that? Or was it kind of a unique distinguishing feature in the room?

CG: There were other things like that in another part of the library.

DW: OK. And it's a normal human-size hand?

CG: No, it was smaller.

DW: Oh, it was smaller.

CG: Yeah.

DW: OK.

CG: It was a smaller-- and a smaller globe, smaller hand.



DW: Interesting. OK. What are you feeling at this point? Are you excited about it? Are you nervous? Are you--

CG: I'm excited because I know that we're about to go talk about what we had initially started to talk about, which was the ancient aliens, the genetic programs, the "meaning of life" kind of stuff that we were starting to discuss. Their belief systems that I was curious about.

DW: OK.

CG: So this whole library complex was made of this white marble.

DW: Now you say library. Are you seeing book stacks, like a library?

CG: We do, at one point. But when we first walk out, there's a big, largely uninhabited area of those same kind of seats, and some of them were reclined back.



DW: The egg-shaped thing that you sat in when you interfaced with her? OK. And they're anti-gravity, right?

CG: Right.

DW: OK.



CG: And there were three levels of the library. There was the library proper that had actual shelves in it, that as we walked through it, there were scrolls sitting on kind of an angled shelf. They were just setting there. There were-- as we went along, there were tablets that were on different types of stone.

DW: Wow.

CG: And then some that looked like they were molded tablets, that were molded out of some type of composite material that were not stone. And then as we moved, they started to look more like books. Some were bound in leather, and some were bound in hemp, or something like that.

DW: Now, if you go to the Louvre and you see the "Mona Lisa" or things like that, they're going to be behind glass. Was there any protective stuff around these scrolls and things, the tablets?

CG: Not unless it was energetic.

DW: Wow.

CG: It looked like you could just reach and touch it.

DW: Wow. OK.

CG: So she was just-- it was like we were walking through, almost like a time capsule. It was changing. And then we started getting to an area that looked like books from 1500s, 1600s, all the way up to-- we got to an area that looked like books could have arrived from Amazon.com. They had the ISBN number kind of things on them that looked--

DW: Really.

CG: Yes, that were on a bookshelf.

DW: UPS? FedEx?

CG: I don't know how--

DW: Who drives down there?

CG: I don't know. But--

DW: Maybe the drones, right? The Amazon drone.

CG: Right. And I asked her, I said, are all of your books in physical form? And she said, no. She said, we keep certain books in physical form that are on subjects that we find intriguing. She said most of them are in a format that we can pull up and read and look at.

DW: And I suppose they're not so interested in underwater basket-weaving and Betty Crocker's "Guide to Home Cooking."

CG: Right.

DW: This is more of what kind of stuff that they're interested in.

CG: Well, where she'd stopped me was at a place that had a whole bunch of books on the subject of ancient aliens.

DW: Did you see any books that you recognized from the surface?

CG: Yes.

DW: Could you give some examples?

CG: Yes. Zecharia Sitchin's books.

DW: Really?

CG: And some books of some authors-- I-- I really can't remember their names. Erich von Doniken--

DW: Von Daniken? OK.

CG: Some other ones. And there were a lot of books in German and Fren-- other languages on the subjects that were there.

DW: Well now, if they can get books, that would also imply they can read anything that's on the internet.

CG: Yes. They-- they have complete access and follow the internet very closely.

DW: Wow. Very interesting. So this is crazy. They're-- but if they could portal you out of the room, then they could potentially be portaling these books out of a warehouse or something as well, right? They don't need FedEx to be driving down into the cavern.

CG: Right.

DW: Yeah, OK.

CG: So I-- I really was not looking at all the logistics of, you know, how exactly they got the books.

DW: Right.

CG: Very quickly, we started to talk about the ancient Sumerian culture, the ancient pre-Akkadian Sumerian language that her people spoke.

DW: Right.

CG: And she brought out a-- she went and then came back with a book that was a dictionary, that was an ancient Sumerian dictionary. She says we have one very similar. It was-- she said, ours has-- it's a dictionary, a complete Sumerian dictionary that has two different languages-- I think Akkadian and Sumerian, or I can't exactly remember-- that is a dictionary for every ancient Sumerian word, what it means. They tell us, the scribes tell us in their own words.

Their book--

DW: This is sort of similar to the Rosetta Stone, which is what allowed people to crack a lot of these ancient languages in the first place. Because it was the same words in, like, three or four different languages.

CG: Right. And we've had this, supposedly, on the surface for I don't know how long, that our mainstream scholars use.

DW: OK.

CG: But her book had three languages. The dictionary had three languages. It included her language, the proto or pre-language.

DW: So she brings out this dictionary. Was it an unusually large book?

CG: It was a very large book.

DW: OK.

CG: And we didn't really-- she just showed it to me. And I looked at it, looked at some of the symbols, the writing. We really didn't flip around it because I didn't understand what it said anyway.

DW: OK.

CG: And she began to tell me a story that made me a little uncomfortable in the beginning, about the story of the Anunnaki, the ancient Sumeria, and the current narrative that many in Ufology and believers in ancient aliens subscribe to. And she went on to talk about how all of the information-- and she pointed up to Zecharia Sitchin's books. She said all of the information in those books is pretty much contrived. She said, you cannot take those books, and you cannot go into an ancient Sumerian tablet, to the tablets and texts, and do translations and get what is said in those books.

And she asked me-- she said, do you know what Anunnaki means? And I said, well, I've been told, and I've read, that it's a catchall term that just means "extraterrestrial." It can mean any group that comes from the sky.

And she said, the root of the word means "royal seed." And I was like, OK, I can't dispute that. I can't-- how do you argue or dispute that? I was like, OK, I'll just listen.

And she went on to describe that there was a secret society that had put out this narrative, very cleverly, to make an elitist religion, to take an elitist religion from the surface and put it into the esoteric community.

DW: Wow. This is really mind-blowing, and I feel like I gotta add something here. When I went to college, I had a buddy who ended up living in a boarding house with me after I graduated. And we'll call him Antonio. It's not his real name.

He was from Spain. Here's the thing I have never said before, OK? He was personal friends with Zecharia Sitchin. He told me that he talked to Zecharia in person, and Zecharia told him that he was told what to write in the books by these Illuminati. None of it was really based on research. It was all contrived. Now, I've never shared that before, and this is blowing my mind, that she's telling you the same things. Very interesting.

CG: Well, she said that the writer had three people that were giving him the narrative to write. And that these three people gave him the narrative that he wrote, that was a very clever infiltration of these, I guess, Illuminati into the Ufology esoteric community to make their religion, our, or their religion.

So this opened up all kinds of questions for me.

DW: Wow.

CG: You know. Because I-- before-- I never would have entertained this before. Because I had seen a lot of information in the glass pads that led me to believe that the ancient Sumerian texts' translations were not accurate. But I stayed away from it because a lot of people have made a religion out of it.

DW: Well, and at the Conscious Life Expo a few years ago, before he died, I ended up in the elevator was Zecharia Sitchin, and he was scared to death of being in the same elevator with me. He did not want to acknowledge that he knew who I was, but it was obvious that he did. He was highly uncomfortable. He didn't want to look me in the eye.

In fact, he actually kind of turned his whole body towards the wall of the elevator, because he didn't want to be in it. It was a weird synchronicity that we ended up, just the two of us, in this elevator for a ride going up, I guess, seven stories or something. Wow.

CG: So for me--

DW: But people see Zechariah Sitchin-- it's like you can't question-- it's, like, sacrosanct.

CG: Yeah.

DW: The stone tablets.

CG: It's like a prophet. Yeah.

DW: Here it is. Boom.

CG: So. But I was very-- you know, I was considering the source. I had a connection with her. But at the same time I wasn't sensing, intuitive empath, any deception. Skipping later on, over weeks, I started studying online, looking at ancient Sumerian websites for mainstream science, looking, trying to verify what she said. And I-- I was shocked.

DW: So you're looking at words in Sitchin's books and what he says they mean, and then looking at the actual online translations of Sumerian.

CG: And actually, story lines that just don't exist.

DW: Wow.

CG: And just don't exist. And--

DW: So if that's true, then that means that we've been sold a bill of goods, if we combine what Antonio said, it's the Cabal, the secret Earth government syndicates, just like with the **William** Shakespeare plays, where they're actually leaking royal scandals from that era in the British Royalty, into these plays. And Shakespeare was illiterate. He could only sign his name with an X. It was actually probably Francis Bacon and a bunch of others.

CG: Right.

DW: Queen Elizabeth's illegitimate son. This is like the same thing again. Sitchin is just the front man for a team of writers.

CG: This was just a little way to open up a huge conversation that just has blown my mind, with her.

DW: So this is still just the beginning?

CG: Just the beginning.

DW: Wow. OK.

CG: Because we got into--

DW: Well, we got time. We'll do more episodes here.

CG: We got into which came first, the chicken or the egg, kind of thing. Because I asked her, I was like, we've talked. You've talked about how many, many hundreds of thousands of years ago, a group came into our solar system and started messing with our genetics. And your people called them a genetic farmer group. So doesn't that match what these texts are saying?

How-- you know, how can you be the first humans on the planet? Who created you? You know, who

genetically developed you? Were you brought here from another planet?

And that opened up a whole other area. And she says, well, doesn't that get you to start asking questions, who engineered the engineer of the engineer of the engineer? At some point, there has to be some sort of an original being that wasn't engineered genetically. And how did they come about being?

So I'm sitting here, my mind's just-- my grapes just went, tt, tt, tt, tt, tt, you know?

DW: OK, but a couple basics. Sitchin's saying Anunnaki were extraterrestrials. Came to Earth mining gold and created a primitive worker called the Adamu, which becomes Adam in the Bible. True or not true, according to her?

CG: Not true according to her.

DW: Really.

CG: No.

DW: That whole narrative?

CG: The whole narrative.

DW: Oh! That's a big adjustment.

CG: Yeah, it's a major adjustment that-- out there, don't take my word for it. There's plenty of information to go out there. I had to go and do the research for myself. There's a website, Sitchin is Wrong, that has a whole bunch of information. The person that has the site definitely is biased in certain areas. But there's a lot of other information out by mainstream academics that are professionals on Akkadian and Sumerian, that have looked at all of these tablets. And the information, when I looked at it myself, I had to come-- I had to come to the conclusion that they were correct.

I'd started to ask, what did your people first think, before you all became an advanced civilization-- how did you all come about? And she said that we believe that the Earth is sentient, is a sentient life form. The sun is a sentient life form, and that everything in the cosmos is a sentient life form. And that the Earth was a sentient life form, and that each of us are an expression or a sentient life form that comes from the Earth, and that we would live and die and return to the consciousness of the Earth. And

that's what our root belief system was when we were developing civilization. And I was like, that's interesting.

DW: Yeah, that's cool.

CG: And then she started talking about how the solar system and the galaxy are sentient. And they are a creative, sentient life force.

DW: Just like the Law of One says.



CG: Well, if I haven't read all of that. But I told her that I've heard the term "logos" used. Is that an accurate term? And I'm not exactly sure the full ramifications of what the word "logos" mean, but I've heard that used similarly to what she was saying.

DW: Right.

CG: And she smiled and said, that's as good a word as any.

DW: And that word is all over in the Law of One, describing that intelligence of the cosmos, intelligence of the sun. In fact, they say the One Infinite Creator, the intelligence of the universe, is the logos, that there's a galactic logos, which is the mind of the galaxy, that designs an evolutionary curriculum for all intelligent civilizations in the galaxy.

CG: OK, so this goes onto what she says. To get to the point of how life comes up and how not everything is genetically engineered by a genetic engineering race that travels all over the cosmos, creating and seeding, you know, bipedal creatures.

DW: Right.

CG: She said that each solar system-- I mean each sentient galaxy and each sentient solar system have a resonant or vibratory template that drive the life form that they will create. And that depending on where the planet is in the solar system, it will determine what type of sentient life form it will try to create. And that throughout the many cycles on Earth, the Earth and the sun have kept on and kept on and kept on creating sentient bipedal life forms, and that there have been many, many, many, and that some of them have died off in cataclysms. And many of them had been killed off by us, the mixed race, on the surface, they're so aggressive. And the ones that exist now exist in solitude in regions of the Earth hiding from us.

DW: Well, I guess if you're actually not going to read the Law of One, that the Sphere Beings will introduce you to people who will explain it to you.

CG: Yeah.

DW: Because that's all in there. And you haven't read these books yet, but that is exactly what it's saying. There's subtle differences. They don't really go into detail about previous human civilizations on Earth. But the bulk of what you just said is what the Law of One teaches, that the human form is the logos. That it's the embodiment of the logos. The logos made flesh, the word made flesh. Logos and word are the same thing.

So you look in the book of Genesis. In the beginning, there was logos. And the logos was God, and the logos was with God. And in the Law of One, that seems to be implying the logos is the mind of the cosmos and the mind of the galaxy, and they're one, but they're also distinct from each other. It's very interesting stuff.

CG: We had a little bit more of a conversation. We were sitting at a table, at a corner of a table. She was sitting and I was sitting, having this conversation. And then after this, we finished the rest of the tour, to where we were done with the library level. She took me down to the second level to where

people were reaching out with their minds to people on the surface and having communications with each other in group sessions. And then below that was what they called their Hall of Records.

DW: Cool. So let's get back to this logos thing for a moment in the short time we have remaining. Because I want to point out a couple of things the Law of One said that are really interesting.

First of all, they say that the sun is indistinguishable from the consciousness of the galaxy, that the sun is the logos. Then they say that the planet Earth is a sub-logos. And then they say that we, as human beings, are sub-sub-logoi, meaning that we are also-- it's like the principle of a fractal, where you can zoom in on it, and you keep seeing the same image repeated as you go in more and more. You just zoom in, and you keep seeing the same pattern.

And so in the Law of One, they explain the universe is like that, that it's the same embodiment of the same cosmic mind that ultimately made everything, and that we are that mind, that any one of us has enough power within ourselves to reconstruct the entire universe. And I think we've been greatly disempowered. The degree to which we are wired into the cosmos has been very carefully occulted from us.

Now, did these people say that there was any truth to the Sumerian tablets at all? Were they the Anunnaki, in fact?

CG: She said that the Sumerian tablets were an extremely accurate scribe history of the time and should be taken fairly literally. She said that some of the Sanskrit writings had some of the more interesting information about some of the things that happened above the Earth and in the stars.

DW: So that would be, like, the Hindu "Vedas," the "Vendidad," the "Mahbharata?"

CG: Right.

DW: OK. That makes sense.

CG: She said some of that information had a lot more-- we had a conversation about ancient myths, and then how the surface people, how we are with our myths, that we create our current myths. We have our ancient myths. And some of the myths are very historical.

DW: Well, and you see images of Krishna and he's got blue-tinted skin, and you're saying one of the groups that you saw down there had blue-tinted skin.

CG: Mm-hm.

DW: So those wars that we read about in the "Mahabharata," in the "Vimanas"-- which it does say, in the "Mahabharata," they can fly right through the side of a mountain, just like you saw-- this could have been the same people at that time warring it out on the surface.

CG: And she-- the council, their group, had talked about, they had open conflict with these ET races in the skies that all of the Earth humanity saw through different cycles, including our current accepted Earth history cycle.

DW: And this gets into blond-haired, blue-eyed Greek gods on Mount Olympus which could apparently lift off the surface of the Earth and disappear.

CG: Right.

DW: Wow. So we're going to come back next time, because obviously there's more to discuss with this. We're going to get into the rest of his experience with the tour-- including, as you were saying, this very bizarre scene that you kind of alluded to in the write-up, about people sitting in chairs and telepathically influencing folks on the surface. And the Hall of Records, which I have never heard you describe before, so I'm very interested. I am on the edge of my seat. That's coming up next time here on "[Cosmic Disclosure](#)." I am your host, [David Wilcock](#), and I thank you for watching.

[Cosmic Disclosure: Inner Earth - Into the Hall of Records](#)

Season 3, Episode 7

DW: Welcome back to "[Cosmic Disclosure](#)." I'm your host, [David Wilcock](#), and I'm here with **Corey Goode**. This is a pretty big set of things to drop on people. There are certain, as we've said, UFO religions that involve people, first of all, taking Zecharia Sitchin as if he's like the prophet and revelator of Jesus Christ, so to speak, except he's a prophet revelator of the Anunnaki as being extraterrestrials that mined gold on Earth, may be a primitive worker of the Adamu that the Epic of Gilgamesh is actually the story of Genesis of Noah's Ark just kind of shortened down. And people, now, then take that as absolute truth.

Now, you said you actually looked up the words that Sitchin was saying meant certain things on your own. You did your own homework.

CG: I did.

DW: And what happened?

CG: Over three weeks.

DW: What happened?

CG: It was not matching up, and it was working out exactly like the scholars were saying on the internet it would. And there was no talk at all of mining gold.

DW: Really?

CG: There was no their there.

DW: All right. Well, one of the other things Sitchin says-- let's just get our hands dirty here. He said that he surmised that there was a super Earth that he said the Sumerian tablets called Tiamat that was destroyed and became the asteroid belt. And you did say that this priestess told you, and others in the Alliance told you, that there were surviving human civilizations from planets that were destroyed in our solar system.

CG: Or made uninhabitable.

DW: OK. And you also said in the previous episode that the priestess said that the actual data in the Sumerian cuneiform is remarkably accurate if it's translated properly.

CG: And looked at literally and not looked at and made into what you want it to be.

DW: Tiamat. Was that a planet that was destroyed and the survivors came here? Is that part correct?

CG: Yes. There was a planet, according to also them, at one time, that was a super Earth that existed in the area of the asteroid belt.

DW: OK.

CG: Well, let me get back to the conversation I had with her.

DW: Sure. Sure.

CG: She talked about-- she went into deeper context about billions of years ago--

DW: Billions with a B. OK.

CG: B. There was an ancient race called the Guardians that had long since left our frequency. And according to her, them, this was the same race that the Secret Space Program calls the Ancient Builder race.

She said that the Guardian-- it's hard to call it what they call it, but she said this Guardian race were extremely advanced and powerful, and protected this region of the galaxy, these local star clusters. And there wasn't any different ET or other groups that would think of violating their territory, their space, and that even after they had left this frequency, they had types of energetic barriers that protected their zone that was theirs.

Inadvertently, these groups on these other planets in our solar system that were native to our solar system, they didn't come from somewhere else. They grew and developed on these planets here. They were very aggressive, very technologically advanced. Somehow, their weaponry, or whatever they did something very cataclysmic that destroyed, did massive destruction to a planet, and also energetically brought down this massive protective field.

And in doing so, it sent out a beacon across the cosmos that, at that time, all of these ET races then started rushing in to their space.

DW: Now, you had given an estimate from the smart glass pads before about when the Draco arrived, and I think you said it was 375,000 years ago, roughly, that they told you.

CG: I've heard 340,000 and 370,000 years.

DW: 370. OK. So that fits in with the timeline in the Law of One about when this super Earth was destroyed.

CG: Right. And also around 500,000 years ago, there were other groups that came here before the Draco. The Draco weren't the first.

DW: OK.

CG: Then these groups came started coming in that her people referred to as genetic farmer-type groups, and they came in and started taking survivors from these other planets and moving them to Earth as refugees, and that's what started to cause all the massive problems here on our planet and in our solar system. That was the beginning of all of these huge genetic and other experiments that are not just genetic. The spiritual. All kinds of experiments that they're doing.

DW: So mass immigration was able to occur once this protective quarantine went down.

CG: Right.

DW: And everybody starts playing around, farming, moving folks around, experimenting on them. So some of these Super Federation folks got here all the way back then?

CG: Right.

DW: And this great experiment that they're doing. That's where this all started?

CG: Right. According to these people.

DW: This is connecting a lot of dots. It's very interesting.

CG: It was connecting a lot of dots in the smart glass pads too, but you know, this was coming from people that had admitted to deceiving people on the surface, to believing they were ETs and gods. So I was keeping my critical thinking cap on, but so much was matching, so many dots were coming together, it was just blowing my mind.

And she then said that everything changed after the return of the Guardians.

DW: What are we talking about?

CG: They call the Sphere Being Alliance the Guardians. They refer to the Sphere Being Alliance as the Guardians.

DW: Well, that's huge, too.

CG: She wanted to know why they have been reaching out with their minds to the Guardians, and the Guardians have not reciprocated the communication. And their people wanted to know why-- why they wanted an audience with the Guardians.

DW: Their people? I don't understand what you're saying.

CG: The Inner Earth people wanted an audience with the Guardians.

DW: OK? They wanted to know why they were being rejected.

CG: Well, yeah, or not acknowledged. Not even acknowledged.

DW: Yeah, that's got to hurt.

CG: The same thing that was happening to the different ETs, and the Secret Space Program, and the secret Earth governments.

DW: And then along comes, in Harry Potter terms, this mudblood mixed guy, and he's the only one they're going to talk through.

CG: Right. And then I told her that they had said that there are many ET groups here that are positive, but they are still a certain percent service to self because they have agendas. And that didn't set well with her, and she said, well, wouldn't that make the Guardians service to self? I said, what do you mean?

She said, they are here on an agenda. They are here on their own agenda.

DW: In Law of One terms, they have direct access to the Logos like you're accessing the internet, and they're following its will.

CG: Well, I didn't have an answer for her. And I said, in what way? And she said, those of the higher frequency are being-- they have residual connections with those of us back in the lower frequencies, and they cannot progress back to source. We're like a parachute holding them back, and that they have to come back and help us progress before they can move forward. So they have an agenda too.

DW: It says in the Law of One that they cannot go from sixth density to seventh density, the group doing the channeling, until every person on Earth has transitioned into fourth density because of the mistakes that they made building the Great Pyramid, thinking it was going to be a tool for ascension,

and then having that object and the religions associated with it getting co-opted by the elite and turning into what most people call the Illuminati.

CG: So I didn't know how to respond to her to that.

DW: Well, next time, bring me down there, bro. If they'll let you, I'd be happy to explain.

CG: We talked about a few other things. I didn't understand. We talked about the wheel of karma and about how her people have not fully accepted karma. And I thought that that was kind of an oxymoron.

DW: They don't acknowledge that it works?

CG: Right.

DW: Really?

CG: And we kind of got into a conversation about that. You know, how could you not understand karma? You should kind of see karma in your life right now.

DW: Well, now these people sound more in Law of One terms, more like fourth density than third density.

CG: They claim to be fourth density.

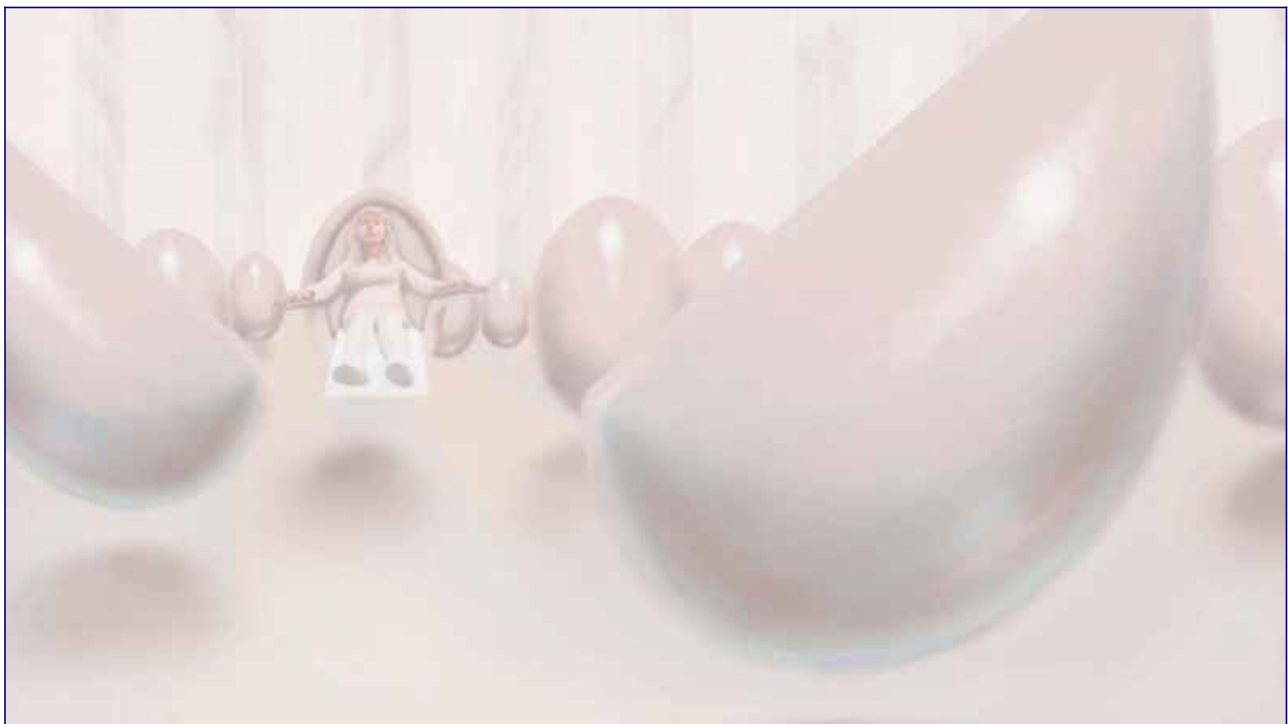

DW: OK. So then that would mean that, like, in Law of One terms, third density's 100 times more intense karma and suffering than fourth. So you could go a lot longer in fourth without actually seeing the results of your karma, whereas in our reality, like John Lennon said, instant karma's going to get you. So they might not be experiencing that. It's very interesting.

CG: Yeah. So pretty much, we had gotten to the end of our conversation, and we got up and we were leaving, and she said she wanted to show me the next two floors of this library area. And we walked downstairs for this. The next floor was this huge area of those egg-shaped chairs, and there were a lot of people sitting in them. Some people reclined, some people sitting in circles.

DW: As in hundreds of people all together, maybe?

CG: A lot.

DW: OK. Many hundreds.

CG: Yeah. There were a lot.

DW: Was it noisy? Were people talking?

CG: No. It was completely silent.

DW: Really?

CG: And we walked right from one end to the room right down the middle to the other end of the room.

DW: Was it all open, or were people in little rooms?

CG: It was all open.

DW: Really? Just one big, huge room and everybody sitting in these--

CG: Right.

DW: OK. Wow.

CG: And she was telling me-- we were communicating telepathically. We're interfaced. We're not verbally talking. She was telling me that all of these people are sitting and waiting to receive

communications from humans on the surface that are reaching out with their mind, or they are reaching out to people or are having an active communication with people on the surface.

DW: So you're talking about channeling.

CG: Right.

DW: Wow.

CG: Telepathic communication. And then there was another area to where there were people sitting around, and she said that they were having a shared experience to where they were viewing information from either the library's Hall of Records and having kind of a telepathic teleconference together, viewing information and discussing it while in a reclined state.

DW: Something that we rushed through before on this show, but people who read your report of part 1 would have remembered seeing is that when Gonzales gave his little speech to the Inner Earth Alliance, and then they came up and all started taking shots at him, one of the things you said they said was that they were going to deliberately disinform the contacts they were in touch with on the surface telepathically because of you guys learning this information and them being forced to give it to you by these Guardians that have showed up.

CG: Yeah. They said that they've had a lot of the people they're in contact with starting to question them, and that they were coming up-- they were going to have steps communicating with those people, telling them they were special. Other people were communicating with tricksters. They were not happy about us exposing them.

They think that that program that they're doing is essential for helping humanity spiritually to overcome certain programming, and it is essential for also them strategically.

DW: So it's like operational security, same thing that Cabal does with seeding disinformation to try to protect their secrets. Wow. Now, anybody who's been following you online knows that it seems like every weekend you and I are exchanging e-mails about this all the time.

We're definitely not going to name names, but there's a flavor of the week channeler who keeps popping up trying to co-opt all the stuff you've been telling me on the show. But then they wildly change it all around, and rearrange everything, and try to blend it into their story. It seems like every

week somebody's doing this.

So are they telling you that these people, or at least some of them, are actually being influenced by them to make up these stories? To try to cloud the truth with disinformation?

CG: Yeah. I'm not saying that all channeling is corrupt by any means, but the vast majority is interference and people feeling that they're special, overconfident in their spiritual strength and abilities that are connecting with the subterranean beings.

DW: Well, it's also--

CG: And these subterranean beings, they have quite a bit to offer if they just communicate with people as who they are and give a lot of the spiritual information. They just don't want to give up that they're below the surface and have us come down there looking for them.

DW: So what are these groups telling people? What is the-- if they're talking to people on the surface, they're not necessarily giving them truthful information.

CG: Well, they're approaching them as ascended masters, ETs from different star systems, sometimes as religious icons from the people's belief systems, and passing on positive information.

They're not giving them negative information that's trying to hurt them, they're trying to help people overcome what they see as our negative genetic and environmental programming to become better and to help start changing society from afar, remotely. Remotely influencing.

DW: Do they have the ability to create, for some folks, like a holographic apport, or image of their form or the form they choose to project?

CG: They can create all that in your mind.

DW: Right. Because you read some of these books, people say they've seen ascended masters, and they're describing what appear to be in-person contacts or apparitions, so they do have that technology.

CG: Right. And a lot of times, it's a shared thing to where people are contributing to the experience. The people are contributing a star system that they're communicating with, they're contributing a religious icon that they're talking to. It's bi-directional communication. So the people on the surface that they're talking to are also contributing to this shared illusion.

DW: So these folks feel like they're seeding a more spiritual perspective into humanity.

CG: Remotely, yeah.

DW: And that the good outweighs the bad in terms of the ultimate goal of what this is all about, to reduce our aggressiveness, to sort of vibe up the planet.

CG: Yeah. And to protect operational security, to protect their cultures, and keep us from coming after them.

DW: OK.

CG: Now. So basically, that's pretty much all to report other than the last floor, the Hall of Records. And this is going to tie-in something very important.

DW: Great. Let's get right into it.

CG: When we went down to the bottom floor, we couldn't go in. It was very bright.

DW: What do you mean you couldn't go in? Was there a barrier?

CG: We couldn't go in. It was a complete, like, dome all the way down to the bottom. Nothing flat. It was a complete dome, and you could see in through, like, a window, but there was no glass. But there was some sort of field there.



DW: So the floor of the dome was below where you were standing?

CG: No. We walked up to the dome on the bottom floor, but we couldn't go inside because it was extremely hot, and almost like a clean room, they had it totally regulated. People couldn't go in and out. And inside the room was a single crystal just like the crystal from the crystal cavern.

DW: That you talked to when you were 11 years old?

CG: Right.

DW: Wow.

CG: They had it in a state of trying to get it to grow.



DW: To grow?

CG: Yeah.

DW: Wow.

CG: And the information that was in that crystal, people were telepathically connecting to in the floor above as well.

DW: Isn't that something? What was she saying they were getting out of it? Did she tell you what was the information inside the crystal?

CG: No.

DW: Ah.

CG: No. She showed it to me, told me that it was in the process of growing in the chamber, that they were drawing information from it, and now I see why my experience was so important to them to share, and that experience is going to be shared with all of the people.

DW: It's also very interesting just that the raptor is-- it's like the archetype of the dragon guarding the virgin and the treasure. The raptor, these nasty, bird-like reptilian are like the dragon, and the treasure is like the crystal, and you happen to get in and see the treasure, and this is all they wanted.

You said that they told you this is like the only thing that we mixed bloods have to offer them was your experience interfacing with this crystal that they can't get to because these dragon-like raptors are guarding it.



CG: And Gonzales told me that that wasn't true, that they needed us or they wouldn't have approached us.

DW: Well, if they can't talk to the Guardians themselves, then obviously, they need help.

CG: So after this, it's fairly easy to wrap up. She said that the others were returning from their different realms, that we needed to return for the cleansing ceremony again. This one was much more embarrassing.

DW: Much more embarrassing?

CG: Much more embarrassing. Each person-- there were people standing in the water this time and cleansing you.

DW: Really?

CG: Yeah. You'd stepped up into the water, and they cleansed you.



DW: Sort of like flying through the TSA.

CG: Right. So I was--

DW: Except with no clothes.

CG: Yeah. I disrobed, stepped up, was cleansed, and stepped down, dried off, put on my original clothes.

DW: Was it all done in a very ritual, ceremonial? OK, I figured. Yeah.

CG: Put my clothes back on and walked back out, the room where the priestess was, and she walked me to about 20, 30 feet away from the center of the room. We said our goodbyes, and I walked to the center, flash, I'm back in the living room.

DW: Wow.

CG: And there was a time dilation effect involved with there, too, in that situation as well.

DW: So you left and come back pretty much spliced in side by side.

CG: And I was gone a long time.

DW: Where do you think this is heading? Have you had any further contact, telepathically or otherwise, with this priestess or with these Inner Earth people since this first meeting?

CG: I've been spending so much time up in my head with this information. A lot of this stuff, I was looking up on the internet trying to verify, especially a lot of this ancient Sumerian Zecharia Sitchin stuff. Very little of this stuff that's on the internet that you can verify, but I wanted to verify what I could. And the rest, I've just been-- I sit around and I've just been blown away, and thinking and thinking about it, and it's changed me. It's been a very life altering experience.

DW: You also reported off-camera-- maybe on camera, I don't remember-- that you've had a lot more intuitive things happening since this occurred.

CG: Yeah. Just about everyone I've been hanging around, I feel their emotions, and what they're thinking, and what they're feeling, you know, and it's been very strong. I don't know if that's something that was enhanced from my connection, that mind meld with the priestess and is something that will wear off over time, or if that is just some new change.

DW: Phew. Well, this has been quite something.

CG: Yeah.

DW: We have a lot more coming up here. I've actually gone through and looked at all the things that he and I have talked about, and there's a lot more content still to come here on "[Cosmic Disclosure](#)." I'm your host, [David Wilcock](#), and I thank you for watching.

Cosmic Disclosure: Inner Earth - Debriefing with the Alliance

Season 3, Episode 8

DW: All right, welcome to "[Cosmic Disclosure](#)." I'm your host, [David Wilcock](#), and I'm here with **Corey Goode**. And we are following up where we left off in the previous episode with this astonishing journey that he had to the Inner Earth. Now, **Corey**, after in the last episode, we described that you were portaled out from the Inner Earth and you end up back in your living room. But obviously, Gonzales wanted to know what the heck was going on in that library that he didn't get access to but you did.

CG: Right.

DW: So what happens next? You said that you got spliced back in to the time that you left when you ended up back in the room.

CG:: Right. Within probably less than 24 hours, I was contacted by Gonzales. And we met locally.

DW: In person.

CG:: In person. And had one of our discussions over a beer and talked tentatively over a lot of the stuff that went on. He was giving me some new intel finally about a lot of the things that were happening in the Earth Alliance, a lot of things that were not going so well, things that were falling apart, and that there was going to be a big SSP Alliance Council meeting and briefing that I was going to need to be a part of to discuss the part of the meeting that he wasn't at, which involved the library.

DW: I'm curious on a personal level and also for the show, what is the problem with the Earth-based alliance? We know that there's a significant Eastern component to it, right?

CG:: Very much.

DW: It's coming out of China and Russia. So does it have to do with China in some way? Or what are we dealing with here?

CG:: The Earth Alliance is made up of many dozens of small groups. Some of them are even militia groups. But the vast majority of them are some Eastern secret societies and groups that have a lot of clout and access to a lot of physical treasure and information.

DW: Now, one of the things that a lot of people don't seem to realize is the Chinese alone are holding \$4 trillion in US bonds. And if they decided that they got a wild hare and wanted to trash the US economy, they totally could. And that apparently has been one of the threats that they've been using to try to get things to change. They don't want to destroy the US economy because that's where their economy lives off of. We're the ones buying their products.

But at the same time, they're holding a very powerful card there with that \$4 trillion of our asset base, which is more than we have. They basically now control the wealth. It's just that they're not getting representation in the World Bank and the IMF for voting rights.

CG:: A lot of the same people from IMF are now power brokers in BRICS.

DW: OK. That's what happened after the AIIB, the Asian Investment Infrastructure Bank, got started.

CG:: Exactly. So what has happened with the Earth Alliance and the Space Program Alliance don't have the exact same agenda. They have the same overall goal.

DW: Do the people in the Earth Alliance know that there's a Space Program Alliance?

CG:: Not all-- some, yes. And they've met. There's been a sharing of information. All of the data from the data dumps, the high level Earth Alliance have the same data to be able to dump it as well. It's like redundancy to have the information with both parties. The thing that's occurred is that the Earth Alliance has been heavily infiltrated, which is what these so-called Illuminati groups, they're masters at infiltration and then causing groups to split apart.

DW: When the Asian Infrastructure Investment Bank was first announced, which was July 29, 2014, or June 29, 2014, nobody expected like 30 of the top Western countries were going to suddenly jump in. But that's what occurred. So you're saying this is where some of this penetration from the IMF into the Alliance started, the BRICS alliance part started to take place.

CG:: It's occurring on all levels. The West had the 100 year Federal Reserve System. Now the East, they want their 100 years of a new financial system that they say is going to be more fair and more representative of the entire global economy.

DW: But if we release what you were calling replicators, we're not going to need money. So why do they want to have a financial system?

CG:: They do not want what the Secret Space Program wants to occur yet. They want it to happen down the road. They do not want-- they have seen all of the data from these data dumps. They have shared it with some of the Cabal people who have freaked out.

DW: They shared it with them?

CG:: Yes.

DW: That's high treason, man.

CG:: It's infiltration. And some of these heavy duty Cabal groups want World War III more than ever now.

DW: As a deterrent to this coming out.

CG:: Right. A lot of these other groups have been convinced that the data in these data dumps is irresponsible to drop on humanity all at once, that it should be spread out a 100 year time period, and that we should move to a new, more ard-- fairer financial system, Babylonian, that will still be a Babylonian money magic system, but more fair that'll be run by the East. During this, they'll release some of these technologies and some information, some disclosure about ETs, some disclosure about certain things but not let the full genie out of the bottle somehow.

DW: Well, I don't mean to insult the Earth Alliance, but this sounds a lot like when my brother and I would fight over a piece of pie. No yours is bigger, no yours is bigger-- I want. And fight over who gets to sit in the front seat in the car. That's not really the mentality that's going to get us through this planetary crisis where our ecology is threatened and where the oceans only have a few years left, the air only has a few years left. We can't go on using fossil fuel burning technology if we are going to survive.

CG:: Well, that's the problem. They're not a full united entity. They're a bunch of rogue groups that are loosely working together for world liberation.

DW: So they agree on that the Cabal has to be stopped. But after that, there's a lot of variance.

CG:: Disagreement on what comes next. Some of the Earth Alliance do want what the Secret Space Program wants, which is a full disclosure event, tribunals, and then full release of technology to all of humanity and then a transitional civilization to move forward.

DW: Well, there's going to be upsetting information, but everybody wins if that technology comes out. It's like forget about 100 years. Everybody wins.

CG:: Not everybody.

DW: What do you mean?

CG:: Those in control or who want to remain in control don't win.

DW: Yeah, I guess if you could look at it where in a transparent system, there's no reason why all the different aspects of government and where the money goes and how decisions are made, it could all be transparent and put on the internet. There's no reason for it to be hidden, although democratic rule sometimes could lead to bureaucratic inefficiency. Nothing ever would get done because any one person who's got a vociferous opinion could try to sway the whole thing, and it gets bogged down by committee. I was on a board of directors for an interfaith church where that happened. Everybody wanted to have a unanimous vote. You never get that. So nothing ever gets done.

CG:: So there's a huge fragmentation problem with the Earth Alliance, and a lot of people that once who we thought were united with one goal who are now kind of pulling apart saying, well, we're kind of liking this idea of a prolonged change in society and a slow release of information. It sounds more healthy. It sounds like a more responsible thing to do. They're rationalizing.

DW: Are there Islamic aspects of this alliance, like the Sufi Mystery School, things like that?

CG:: There are members of every part of society involved in the Earth Alliance.

DW: All right, so Gonzales is telling you that there's fragmentation in the Earth Alliance. And then what?

CG:: And that there has been some fragmentation in the SSP Alliance.

DW: Really?

CG:: The Alliances have been suffering. A lot of it has to do with these energetic changes that are occurring in our solar system. People are having problems acclimating. A lot of it depends on your spirituality, your polarity, what type of person you are, how you're going to handle these energetic changes.

DW: Well, to use Richard Hoagland's oft-quoted quote, "the good are getting better and the bad are getting worse."

CG:: And the crazy are getting crazier. So we covered that. They said this is going to be a topic in the debrief or the briefing, and that they wanted to hear from me, and that there are some people that were upset that I was alone at the library, and they have to rely on what I say is truth about what happened.

DW: Couldn't they inject you with scopolamine or something then try to extract the truth out of you?

CG:: That kind of stuff is what caused a major rift between us to begin with. No, that was not an option of them to do. But they have intuitive empaths there that are supposed to be able to read any type of deception on my part. But a lot of it is just ego, elbow throwing kind of stuff.

DW: Well, and their goose would be cooked if it wasn't for the Sphere Beings giving them logistics and the intel to make this possible in the first place. So if the Sphere Beings are having you and Gonzales as their delegate, then sorry if you don't like it, but the alternative is they're not getting the support that they need to be able to make this happen.

CG:: And they've been told to stop all offensive activity. No more bombing, no more shooting, no more attacking.

DW: Because these facilities that have been built are going to be turned over to humanity.

CG:: This infrastructure, this huge infrastructure that the ICC Secret Space Program component built is planned to turn that over to humanity at some point, to be the foundation of our new "Star Trek" type transitional civilization.

DW: So they didn't like the fact that you got this information and they got to rely on you to tell the truth. They don't know whether you're going to be lying.

CG:: Once again.

DW: Same story.

CG:: Same old story. So long story short, predetermined time comes, I'm brought to a different base.

DW: This is the Blue Sphere method again.

CG:: Blue Sphere method, brought to a different base, one of the--

DW: Off-planet base?

CG:: Mm-hm, one of the Kuiper Belt bases. And the room is full of the SSP Alliance Council.

DW: Just give us a brief sketch of what this room's going to look like if we were there with you. What would we be seeing? Is it dark? Is it bright?

CG:: It's well-- it wasn't a hugely bright room. It wasn't dim. It's somewhat like the lighting in here. It was not an amphitheater, but it was flat in the front and kind of like a piece of pie going this way around it in the back. And that was the only room I was in.

DW: Like a college lecture hall?

CG:: Right. But it was all flat. It wasn't angled down. And they were all sitting.

DW: How many people?

CG:: Over 60.

DW: Did you recognize anybody from some of the other meetings?

CG:: Yeah. Yeah. Some that I had gotten into it with, and we had kind of awkward forced apologies and shaking hand makeup kind of situations.

DW: And once again, you get the full spectrum of races on Earth in these folks.

CG:: Right.

DW: Indians, blacks, whites, Asians.

CG:: Just like in all the other meetings. I'm brought there, Gonzales was already there and waiting for me.

DW: And you're put in the front while everybody else is sitting and looking at you.

CG:: Front to the side. Nobody's in the front. And I sit down and a few people talk. They're talking about the different fragmentation and the Alliance, different things going on. Some of the things I shouldn't really talk about. And then they wanted to have the debrief of me and what happened at the

library and the hall records and all that. So I get up, and then I give them my debrief, my briefing, and immediately I start getting asked questions or comments start coming out. Isn't it interesting that all of a sudden these subterranean groups are wanting to talk to these Sphere Beings and that makes you all of a sudden more valuable?

Like, I was creating a narrative that made me valuable.

DW: But they've got intuitive impasse that could tell if you're confabulating a story.

CG:: They were being jerks.

DW: They're trying to pose you as if you're trying to write yourself back into the storyline where they're trying to edge you out.

CG:: Being opportunists.

DW: And these are some of the same people you had words with before that were saying this stuff?

CG:: Right.

DW: Interesting. Well, it's the way they think. They're all coming out of a Cabal background. They've always got-- they think everybody's got an angle, everybody's got a service to self-agenda.

CG:: Like what I said, you can tell a lot by a person when they accuse you of something. They're showing you what they would do in the exact same situation, because people overlay the way they think and feel and what they would do unto others. So basically, I gave the full report that I gave in the last episode. And they brought Gonzales to the front, and they talked with him about him making contact with the Sphere Alliance.

DW: Did know that the Sumerian story was altered by the Cabal, that Sitchin was given false information?

CG:: They were not shocked.

DW: Oh, really?

CG:: None of them seemed to slide around on their chairs or shocked at all.

DW: Did they understand that Inner Earth beings were posing as ascended masters and influencing people's channeling?

CG:: They knew that this is something that I've talked about for over year a now. I looked back on my forum postings, and I saw the first time I start talking about it was December of 2013.

DW: Were they aware of these Inner Earth folks had books from the surface of the Earth that they were studying?

CG:: No, but they weren't surprised.

DW: So you didn't really give them anything they didn't already know then?

CG:: Right.

DW: But somebody like Gonzales maybe would have gotten more out of the library than you could have based on his background and training, which probably pissed them off.

CG:: Right. He would have gleaned more intelligence out of the situation than I did. The information about the Guardians being the Ancient Builders, being the Sphere Being Alliance was new to them and made them sit up straight and got their attention though.

DW: Well, and you got the Blue Avians when they say, when those people from the Space Program Alliance asked them, are you the Ra that channeled Law of One. The answer was, I am Ra, and then the rest of their name, which is exactly how Ra introduces themselves after every question in the Law of One. So this all threads together beautifully.

CG:: The Secret Space Program Alliance, a lot of them are not buying into the becoming more loving, forgiveness, and all that message. And a lot of them are having difficulty with the natural law, Law of One type of concepts. And certain groups of them that don't like the idea that there are an indigo or blue bird-type of being that's communicating. There's some issues going on within the SSP Alliance about what's happening with--

DW: Since they have, on the smart glass pads, access to this information that later groups came in and scratched off all the written descriptions of Ancient Builder race, and we know that these groups that came in later were more negative. They were making war, they were genetic farmers-- wouldn't it stand

to reason that they would be obscuring the records that would show that this original Ancient Builder race was far more positive than they were? Isn't that a logical conclusion?

CG:: Yes.

DW: So you gotta just use logic.

CG:: And just on Earth, kings come in, and they scratch off the names of previous kings or rulers or people that owned or had dominion over the land that they now control. Like, monuments may still stand, but they'll be scraped off glyphs and script.

DW: So what happens after that? They're interested in the fact that the Ancient Builder race might be the same as these Guardians, i.e. Sphere Beings.

CG:: So they talk to Gonzales, and they want Gonzales to confab with the Sphere Being Alliance and do what they can to arrange some sort of meeting or exchange between this new Inner Earth Council and the Sphere Being Alliance because this new council was seen as a very positive thing, a positive new spin or change to the SSP Council.

DW: When the people from Inner Earth Alliance went to the Kuiper Belt SSP Alliance base, did the Inner Earth Alliance Council end up meeting with the same people that were in this room with you now?

CG:: Yes.

DW: OK, so they'd already met the Inner Earth folks. So now they're trying to facilitate and broker a deal using Gonzales to get the Sphere Beings directly in contact with the Inner Earth people and thereby eliminating you as the middle man, which they seem to be very keen on doing.

CG:: Well, they looked past me and ignored me and immediately started talking with Gonzales about how they wanted to proceed next.

DW: Interesting.

CG:: And leaving me out of the conversation. So you can extrapolate from that what you want.

DW: What did Gonzales say?

CG:: Well, he said as much of it that is in his control. He would get rolling or see what he could do. But as usual, very little is up to him.

DW: Anything else happen after that? Or was that pretty much the end of the meeting?

CG:: That was pretty much the end of the meeting. I received a few more details about some of the fracturing that had been going on in both the SSP and ground-based alliances, the concerns they had, the worry about a premature release of the data dump information or it being released in chunks, and the Cabal finding a way to corrupt the data that's trying to be released. They were very concerned about what was going on with the infiltration of the Earth Alliance, who had this information, and they knew that they had been sharing this data dump information with the Cabal.

DW: Now, you said that the Cabal is desperately trying to get World War III started to throw off the effect of this data dump happening.

CG:: What was said about that was that there are several different occult sects within the secret Earth government syndicates that have prophecies that they were trying to create in Syria, of Damascus going up in smoke or in flames or something like that, that they wanted to create that they thought would send us on a new timeline or a catalyst to bring about World War III.

DW: Is that like a Biblical prophecy?

CG:: It's a prophecy that they are-- it's a prophecy that several of these groups subscribe to. I don't know if it's a biblical prophecy either, as well.

DW: Why Damascus?

CG:: I don't know. But Damascus going up in a column of smoke or flames or something seems to be something that they were working towards. And then very recently, all of a sudden, Russia comes striding into Syria. I found that very interesting timing.

DW: And it appears from all the stuff that we're seeing from insider sources and just making logical deductions that Russia is actually striking against Cabal proxy armies allegedly called ISIS. Is that consistent with data you're receiving?

CG:: Right.

DW: ISIS is not Islamic at all, or that it's just a proxy army for the Cabal in some way.

CG:: Right. Created by.

DW: Now, you said the Earth-Based Alliance is trying to withhold a full disclosure, or at least some elements of it, so that maybe the Eastern Bloc could stay in control of financial system for 100 years. But not all parts of the Earth Alliance are on board with that plan? There's others that want to see this document dump come out?

CG:: Right.

DW: Isn't it true that somebody could just do it? We have the internet, right? Anybody can post, and they can release information.

CG:: It has to be done at the right time. There has to be a catalyzing event to where all of the rest of the people on the planet are willing to look at the information. If it's dumped and then all of mainstream media says, oh, a whole bunch of crazy conspiracy theory crap hit the internet. And then they're able to shut off access to a lot of these different-- it can be managed.

DW: But that didn't work with Snowden, because you got documents that have TS//SI//ORCON, all these code numbers on them. And you got insiders coming forward and saying, yeah, we know what this is. And you got guys like Greenwald and The Guardian out of London that are endorsing these documents. I would assume a plan like that must be in place for this document dump as well.

CG:: You don't think all those people learned a lesson from that?

DW: Yeah, I mean I was told by **Pete** Peterson, maybe you've heard the same thing, that--

CG:: You can shut down the grids, shut down, shut down, shut down.

DW: Well, he was also told that journalists en masse were contacted by the Cabal and said, you pursue these stories any further, and we're going to hold you upside down, knock the earwax out of your ears, and that's if you get lucky. And one of the big stories that Peterson said that they had, the journalists were about to come forward with, was that the reason why they stopped sending so much power from the whole western half of the United States up these big cables into the HAARP facility in Alaska and rerouted it into Bluffdale, Utah in this new computer facility, was that those computers-- they had data, these journalists-- that the computers were crunching everybody's phone calls and transcribing it just like Siri does on the iPhone. So they had transcripts of everybody speaking. And that story did leak quietly more recently, didn't really get much press. But apparently, they were going to come out with

that in a big way, and the Cabal shut them down.

So you're saying that the Cabal has tried to make it impossible for another Snowden type thing to happen again?

CG:: Right.

DW: It doesn't seem like this is going to work out for them, though. It seems like events are going to just start to snowball and take place that are well beyond their ability to control. So could there also be perhaps some sort of extraterrestrial chess move, where they just decide to decloak a ship and everybody's gotta deal with the fact that there's this big sighting going on. You think that might happen?

CG:: There is a defense grid still on the planet. If the Secret Space Program decided to try to fly around decloaked, they would be shot down and destroyed.

DW: Oh, really?

CG:: Yeah. So this is going to have to be-- a lot of this also has to do with humanity, a lot of us waking up. And it has to do with what we've been talking about, our co-creative consciousness creating a new future and not allowing our co-creative consciousness to be manipulated by these Cabal-type powers that use our co-creative consciousness as the root of their magic.

DW: Absolutely. There's a whole lot of other stuff we haven't covered yet. So come back next time here for "[Cosmic Disclosure](#)." I'm your host, **David Wilcock**, and I thank you for watching.

[Cosmic Disclosure: Ubuntu and the Blue Avians' Message Part 2](#)

Season 3, Episode 9

DW: All right. Welcome to "[Cosmic Disclosure](#)." I'm your host, **David Wilcock**. And I'm here with the insider's insider, **Corey Goode**, who has claimed to be working with the Secret Space Program, which has a very interesting view about our future. They have technology that could eliminate the need for us to have a financial system because if you need anything, you can just hit a button, and you manifest it right out of these replicators.

The interesting thing now is with this special edition episode, we've also brought in **Michael** Tellingner,

who was specifically named by the Space Program Alliance because his Ubuntu contributionism system, they said, is a blueprint for an entirely new way of living on Earth that will be in much greater harmony, where the goods and services that we need can come about in a loving, co-creative fashion rather than in one that involves destructive competition. So **Michael**, welcome to the show.

MT: Thank you, **David**, for that wonderful introduction.

DW: All right. Well, I want to play the lawyer for a second.

MT: Please do.

DW: I want to fan away these clouds of love that you all have been smoking.

MT: Yes.

DW: And I want to deal with some things that the haters are going to come at you with because you're going to be on trial.

MT: Oh, yeah. And **David**, I can say to you that I've heard this for 11 years now.

DW: Well, I got to give these guys their voice.

MT: Welcome to the trial.

DW: They can't speak through the camera. I got to do their voice for you.

MT: Yeah, of course. Yeah.

DW: Every kid in America is indoctrinated with Jamestown. The first people that came to America had this idea where everybody's going to just-- we're going to grow food, and it's going to be amazing. And what you had happened was that all these wealthy landowners came over here, and they refused to work the land. And they starved to death because, well, somebody else is going to do the work. I don't want to do the work.

So this is the rationale that we've all been brainwashed with, indoctrinated with. But people believe it, that if you don't have a competitive, capitalist system, that the need for money, the need to earn money and to procure money or else you will starve, is the only thing that lances the boil of human selfishness

and greed that would otherwise make people want to live off of others and not contribute to the system. How do you address that?

MT: Well, once again, that statement comes from within a capitalist system. The moment you don't have money, where that doesn't even enter the equation, everything changes. When you start working in a structure of collaboration and cooperation, and not in competition--

CG: Or entitlement.

MT: Or entitlement, exactly. I'm entitled to people work for me and all that. This all comes-- this is thousands of years of indoctrination. This is why to deprogram the average person from the way that we think-- we're all born into the capitalist system. We're all born into what we think democracy is the savior. No, democracy is just a bullying tactic. It's not the saving grace. Democracy is part of the problem. We all believe, oh, I live in a democratic country. It's going to--

No, it's part of the problem. It's part of the lie. Capitalism, democracy, competition, the money system-- all that needs to go. Until we get rid of that, we can't level the playing field and create a united community that actually works towards a benefit of all. So to do this has taken quite a number of years, as I mentioned. I've now been doing this for 11 years. And it's been, for me personally, the most liberating journey of self-discovery. And then sharing this with others, some resonate with it instantly. Some take a little while longer. And some just constantly want to reject it.

But once people just open themselves up and absorb some of the ideas, and it starts to resonate with them, there is no turning back. It's like opening that--

DW: Oh, **Michael**. Hang on a second. People are going to be sitting around with their phones. They're not even going to look you in the eye. They're not going to want to do any work. They're going to just be sitting there twiddling their thumbs. This doesn't sound practical.

CG: There's going to have to be a transitional period. And a-- what's the opposite of indoctrinating a person?

MT: Liberating a person.

CG: Liberating people's minds.

DW: You can't make somebody want to do this stuff, right? I mean, they're going to do what they do. And you look at the number of people that are buried in their phones. They can't even have a conversation, look you in the eye.

CG: There's going to have to be a catalyzing event that has been talked about in the Secret Space Program, something like you talked about, a global economic collapse. People are going to be very upset. They're going to realize this has been a giant Ponzi scheme run by criminals. And all of these people that are supposedly in the democratic system that they voted for have been in the pockets of these people the whole time. It's just been a big scam.

When the sleeping masses realize this, that's going to be a catalyst for them to want to know more. And then this is when a lot of document dumps are going to happen. A lot more information is going to come out. And don't you think that's going to stimulate people to be open to new ideas?

DW: Yeah. And the Jamestown model-- let's just address that for a second, **Michael**. They admittedly were coming into a foreign land that they knew nothing about with a very small number of people who were all essentially unskilled, who didn't want to get their hands dirty, and who would've needed to do hard work in order to survive because there was no other way. But we're not living in that society anymore, are we?

MT: No, we're not.

CG: And a slave labor mentality era also.

MT: Exactly.

DW: Right.

MT: When slaves were being sold on the open market. Exactly. So we're living in very interesting times right now where pretty much everyone alive on this planet knows that something is wrong. If you ask the average person out on the street, are you happy with the way the world is going? Are you happy with what the government is doing for us? Are you happy with your life? Do you think this is the perfect life that you were born for? Are you living out your dreams? The answer is 100% no, guaranteed. 100%.

DW: Absolutely.

MT: People tell you no, they're not happy with any of that stuff. So clearly, something is dramatically wrong. So the platform for departure to finding a new system has already been laid. And now we just got to present a new system. And I think we've done that reasonably successfully.

And this is why the Ubuntu movement is growing so quickly, way beyond my wildest expectations or imagination. I never wanted to start a movement or a global movement. That was not my plan. My plan was just to share some information. And this is what happened.

DW: I'm hearing a lot of beads and sandals, feel-good platitudes. I'm not hearing practical things, though. I'm just hearing a lot of philosophy right now.

MT: The practical things is what we need to get to really quickly because that's important. That's exactly what people want to hear. Great. It's great. But how do we get there? How do we get from here to there? This is why it's so important to share those practical steps with people, so they internalize it. They feel confident. It's not just yeah-sure-wow kind of stuff. Right?

So we need to recognize that the communities out there already exist. We're not going to change the system in the big cities and the metropolitan areas. That's a difficult thing to do. I believe that the way to do this is to go into the small towns and small villages where you can reach all the people. You can share new ideas with them and basically just change the way that people think about their own future and how they can start working together, and then become the model for this new way of thinking and the new way of acting and the new way of creating abundance for themselves, thriving.

How do you do this? Well, you can do this by bringing a lot of money into a small town. The other important thing is to say, we're going to have to use money to free ourselves from the money. There's no other way around it. So people that are out there and saying, oh, Telling, you're a fraud. You want money to create this thing. Why don't you practice what you preach and do all this without money? Stop being delusional.

The system has been enslaving us for at least 6,000 years with money. We've got to now take the system and change it so that it works for us. And I just need to come back to what **Corey** said earlier because I'm probably going to forget. The whole philosophy of the Ubuntu movement and the contributionism philosophy is not to oppose anyone, not to fight anyone, not to create a bloody revolution or anything like that. Those days of violence and physical opposition are over.

We are creating a new reality for ourselves. We're taking the existing system and the energies that are being used-- the negative energies are being used against humanity-- taking it and channeling it for our own benefit and just gently converting it so that actually benefits humanity. And before you know it, it'll be serving us in ways that we can't even imagine. And I'm going to show you how. It's so simple and so quick here we can transition this.

So we need to recognize that we can create as many community projects-- and the whole Ubuntu contributionism system is based on establishing a number of diverse community projects within small communities that benefit that town. When I say community, it's either a town or a village or a community of people. And each one of those community projects is then worked. Everybody works for a few hours a week on one of those community projects.

Well, how do you do this? The thing is-- and maybe you get a town that does this successfully, and you start creating all kinds of things, from growing food to technology to anything you can imagine. But as soon as you become a threat to the establishment, they'll send the men with guns, and they'll shut you down. So that is not a solution.

And the other important thing for us to realize is that there are many self-sustaining communities around the world. Have they had an impact on the rest of the world? No. They're just running self-sustaining communities. So a self-sustaining community is really just a bigger version of me, me, me. Now it's us, us, us. So don't climb over our walls. Don't come in unless you're invited. And we're not going to share anything that we do with you because you're on the outside. We're on the inside.

And that's not a solution. This is why I stress always, we are not creating self-sustaining communities. We're creating a whole new way of thinking. We create so much of what we do that we can make it available to everyone around us, either by selling it or making it available for free.

DW: If the Space Program releases technology where you can create any material item or good or food that you want-- you just hit the button and you got it-- how would that factor in? If these people already know they have this and they're using it-- I mean, he said he loved the pot roast button when he was on the ship that he was on. How would that factor in?

Let's say we have that technology. It's given to us. There's a big disclosure. We get that technology. How would this model work with that?

MT: That's a really good question. It's something I've thought about quite extensively. And this is where individual humanness actually comes in. While I might want to use the replicator to make me a pot of whatever, I actually enjoy the art of cooking. I enjoy making a wooden cabinet because I love the smell of wood. Or I love fishing. Or I love the things or the talents and the gifts that I'm born with, to express those things. Otherwise, I might as well put a gun to my head because what am I going to do?

I believe that we are living these lives on this planet to appreciate all the density, the oxygen, the water, the gravity, to experience this planet for what it is, with all the beautiful things imbued on this. That's what we should be doing. And we are each born with very specific and unique talents. And this is what we should be doing.

So you can choose to use a replicator to make you a pair of pants. But I think you're getting a lot more joy by talking to your mother or your granny or the tailor to make a beautiful new sets of clothes for you out of a material that you helped make yourself from hemp and other materials that are biodegradable, that are nontoxic, that are recyclable, that we have created with this density, this reality, on this planet because that's why we're here, to experience this as our reality.

And then when we've had enough, then you decide what to do with yourself after that.

CG: And this technology-- he was talking about the larger metropolitan areas. A lot of this technology might help bridge the gap.

MT: Yeah. So there are some very interesting things that can happen. And so I was leading up to the fact that the community projects is the model that we're using with the Ubuntu movement and-- the critical thing-- with the Ubuntu Party. It's become very obvious to me that unless you give this philosophy of unifying people and creating a new system of abundance, a new social structure, you have to support that on a political level because right now our lives are being controlled and destroyed by politics.

And people say, oh, Telling, you're selling out. You're going into politics. You're becoming just like them. No. We're going into politics because we want to turn this disgusting, dishonorable, crooked,

filthy part of our human-- our lives that's destroying our lives. We need to change it. By sitting on the sideline and ignoring politics, is not going to do anything. It's not a solution.

So what do we do? We have to do something about it. So we create a political party that actually says something completely different. We're going to decentralize government. We're going to shut down the Federal Reserve System and create a People's Bank as an interim that issues money for the people, tax free and interest free. So there's no taxes, no inflation, none of that. So it actually starts serving the people to put into place, in the interim phase, all the community projects and the public works that we need so that you can release the people from their prisons in their metropolitan areas.

And they can go back to their little towns and villages because now they know they're going to find something to do because the money is provided for by the People's Bank. That's just an interim phase.

DW: Doesn't it seem like things are already kind of leading this way? Look at the number of people who will make their own YouTube videos. They know they're never going to make money on it. They'll write articles. They know they're never going to make money on it. They're writing software that's free.

And why are they doing it? Because they want to be seen as socially valuable. They want to have a social status. So do you think that this social competition or social collaboration is going to be part of it?

MT: Absolutely. Really, what you just said there, **David**, is critical. When you start working in your community-- and again, we're still leading up to the practical steps because I think it's critical that we get there. But when you start-- when you wake up in the morning, and you know, as **Corey** said, everything you need is provided for. Why? Because that's what we do as a community. There's too much food, too much technology, too much fabric, too much anything.

Everything is available in abundance. All you have to do is contribute a few hours a week towards the community projects, and the rest of the time is yours. How that will evolve, I don't know yet. But the communities will decide how that's going to evolve. But what it results in, that most of the time you have in the week is your own. And you can then express your own talents, whether you're a painter or a sculptor or a musician or a horse breeder or an engineer or a scientist.

It doesn't matter what you do. You've got the absolute ability to do--

CG: Things that make you happy?

MT: Things that make you happy.

CG: Wow.

MT: Exactly.

CG: What a world.

MT: So when you wake up in the morning with a smile on your face because you know you don't have to get up, get dressed in a suit and a tie, and sit on a train or a bus or ride a bicycle in the rain or the cold or the wind to go to a stinking job that you earn a few lousy dollars every month to pay off your mortgage, to pay the electricity, the milk, the bread, pay for your children's education so they can be enslaved in the same system, and then you start the thing over again next month.

DW: And as Graham Hancock would say, keep your brain pickled with alcohol so that you can tolerate and keep doing it.

MT: Exactly. So now you don't have to do this. So you choose which community you live in. You don't have to-- you're not forced to do anything you want. You get everything for free because you contribute a few hours a week towards one of the community projects. And that collectively makes us a very powerful labor force. I use that as a word, although that will fall off the edge very soon.

But very, very quickly-- overnight-- your community becomes a powerful labor force that no corporation, no municipality, no government can compete with. And now I've actually given you the steps. How we go from here, from today, into a community that is living in abundance and creating all this abundance for itself--

DW: What if some guy goes around raping women at knifepoint? What are you going to do with him?

MT: Well, that's one of the frequently asked questions. So thank you for bringing it up. And what I find interesting, just on that subject, is that the questions that people have been coming up with over the last 11 years shows me how equally wired we are, how the current system has wired us to think equally about the problems and coming up with the same problems, the same hurdles. It's beautiful. So now we know what problems to solve.

But the good thing about this is remember, part of the whole model, the Ubuntu model, is to move away from a centralized government. Communities govern themselves. So I don't know what my community or the community that I'm going to be in-- the community will decide. They'll set up a new legal system, guidelines as to the behavior, starting with the basic, the common law system-- do not kill, do not steal, and conduct yourself honorably.

CG: So you're not talking about, like, a centralized government ideological system in that aspect. Different regions that have their own moral compasses and--

MT: In many ways, going back to like the city-states where every community has its own set of rules and guidelines. And there's a lot to discuss, obviously. But in the Ubuntu model, we go back to the tribal council, where the people of the community elect. And it's an open election. Everyone knows that I voted for [David Wilcock](#) to be on the council of elders. And if [David Wilcock](#)--

CG: Maybe our elders will become respected again.

MT: Well, that's what it's supposed to be. This is why they sideline our elders, and they put them in old-age homes. And we try and get rid of our elders because by the time--

CG: Out of sight, out of mind.

MT: Exactly. And you don't use the wisdom anymore. And so the community will elect its own council of elders that will then be the guides for the community. And they'll decide daily and hourly and minute-by-minute what is best for the community, not what's best for me. Although what I do is, I call this a minority-run system, not a majority-run system. And this freaks some people out. They go, what do you mean?

Because we're so poisoned by democracy and majority rule. So this is a minority-rule system. How can you say that? It's because there are far more minorities than there are majorities. There are an infinite number of minorities. There are those that look after butterflies and those that care about peach trees and the soil and the clouds and whatever, people that make sure the genetically modified stuff doesn't enter our food and all-- there are so many different minorities.

And in a contributionism system, every minority will be taken care of. Every minority will get all the tools, all the technology, all the support, all the labs, all the research, everything you need to do what

you're supposed to be doing for your community. That's why you can call this a minority-driven system and not a majority-driven system, where 51 people tell the 49 people that they can't have it their way.

DW: So the cesspool gets clogged up, right? The sewers are clogged. Nobody wants to go into the sewer. What do you do then?

MT: Great. I love it. It's just beautiful, where it's just one of the frequently asked questions. It's beautiful. Who's going to shovel the crap? And the answer to that is-- normally when I do the workshops and I bring up this as a question, guess what happens? There are always two or three people that put up their hands. I'll shovel the crap. So we already have our answer.

But it goes a lot further than that. Remember, we're no longer doing this for money. We're doing this for our community, which means we're doing it for ourselves. I don't want to have my sewer clogged. So if the sewer is clogged in my community, it means that my sewer is clogged because it's my community.

So whoever is on duty for that week to look after the sewers will go and unclog the sewers. So let's get back to what the community projects are all about.

CG: And there's people that specialize in all these different types of things that can pool all their resources together.

MT: Correct. So this is the-- we also recognize the diversity in our humanness and our community, but the unity within that diversity and the diversity within the unity. There are as many skills and talents and wishes and wants that people have as there are people. Each and every one is completely unique. Each and every one of us is completely unique.

CG: And equally as important.

MT: Exactly. Every one of those trillions of cells in your body plays a critical role in the makeup of your body. And that's what I keep reminding people. Don't think that because you think you're nobody and you're insignificant-- and that's what people do. Oh, I'm nobody. I'm insignificant.

No, you're not. In a Ubuntu or a contributionism system or a contributionist community, you are a critical part of your community. You play, everyone plays an equally critical part in the community. Doesn't matter if you're the local doctor or the scientist or the engineer or baker. Everyone's role is

equally, critically important, just like the trillions of cells in your body.

So the amazing thing is that for every crazy Michelangelo or Leonardo da Vinci, there are 1,000 crazy young chemical engineers who are passionate about solving the sewage problem. And they will come up with systems to solve the sewage problem.

DW: When I was in high school, there was probably about 20 jocks who were always on the morning announcements because they'd won this or they'd won that. They were the fastest runner. They shot the most number of baskets in the basketball team. And then there was maybe 10 or 15 eggheads who kept winning all these academic things. That's the only folks you ever heard about.

Everybody else, hundreds and hundreds of kids, all marginalized. Never got any recognition, never got their name on the announcements. How do you avoid cliques and good ol' boy clubs, where the same thing starts to happen and just a few names are getting all the attention?

MT: OK. We've got to go back to-- most of the questions that people ask about how will this work, the questions actually come from a capitalist society. What you talk about is a consequence of capitalism. Laziness is not human nature. It's one of the frequently asked questions. Oh, human nature is to be lazy. No. Wrong.

Human nature is to create. It's to give expression to your divine-- the talent that you're born with. And that gets beaten out of us in the school system. So when you change your schooling system-- which obviously we're going to have to do completely. We're not going to have a schooling system the way we have today. This is an indoctrination, brainwashing, manipulation prison camps that we send our children to.

CG: I couldn't have put it better myself.

MT: That's going to change dramatically. So when you grow up in a united community, where everything is available to everyone all the time, you're not worried about who-- you love those people around you that are coming up with new technology and new signs and a new way of making bread and a new way of mixing dough or a new way of making shoes or dyeing clothes or new materials that they-- graphene mixed with hemp. Oh, my goodness. What a great new combination.

So because you've taken the lid off, money is not a hurdle to progress. Anything and everything is possible. It's about what you do as an individual that drives you, that you'll be respected and loved for by your community. They'll love you, **David**, because of what you do and who you are. The moment you start driving your ego, guess what your community is going to do? They're going to say, oh. And you're going to know about it very quickly because it's all about whatever you do will benefit the whole community.

And this is where it gets really interesting, when you start understanding the impact of who we become in our communities.

DW: When I came over here from the airport, there was a lady driving the shuttle bus named Teresa for Alamo. She's got two jobs. She works at Delta, she works at Alamo. She's working 16 hours a day.

MT: Oh, boy.

DW: The only way she gets enough sleep is if she does the overnight shift, and she's sleeping from 2 o'clock to 4 o'clock in the morning.

MT: That's disgusting.

DW: She sleeps six hours at home. But when I talked to Teresa, it turns out that she went to Haiti. She had an incredible time there. The fruit was amazing. The climate was amazing. And if she could afford it, she wants to go back to Haiti and create something like a business for all-terrain vehicles where people can drive around, enjoy themselves, do something that contributes to the common good. Anytime you find somebody in one of these dead-end jobs, if you to them about their dream, they got a dream.

MT: Yes.

DW: Everybody has a dream.

MT: It's fascinating. Everybody has a dream. But what I've found, as well, is when you start talking to people in high-level businesses-- guys that have made a lot of money in corporations and the CEOs and all that-- and ask them, so what was your childhood dream? And this is actually one of the saddest things that I've experienced, is many of the people have forgotten what their childhood dreams were. And they really have to think hard about this.

This is what the system has done to us. That's how bad it is. It has beaten us down so deeply and so badly that many of us have forgotten what our childhood dreams are. So I've started a process of probing these individuals, saying, so where did you live? And you have to take them back on their own journey. It's like a bit of a therapy session.

So you take them back. Where did you live? And where'd you go to school? And what did your mom do? And your friends? Did you ride a bicycle? And you take them back, regress them, in a way. And then they start remembering what their childhood dreams were. And you suddenly see how their life-- their whole body language and their energy changes from starting to talk to you very rigid and guarding themselves-- you're talking about a world without money. You're trying to take everything away from me.

No, no, no. I'm actually trying to give your life back to you. I'm trying to give you your childhood dreams back so you can live them out without the fear of somebody shutting your childhood dreams down and hijacking your whole life doing something else.

CG: I'm sorry--is this something that people can begin to practically implement in whatever country they are right now on a small scale? And is there a place where they can learn more about it and start communities and start to do these-- not really focus groups, but these social experiments and show others?

MT: Well, **Corey**, thanks for bringing that up because it comes back to the implementation. How do we do this?

CG: Proof of concept.

MT: Proof of concept is critical. But this brings me back to what happens in community projects. First of all, to set up a community project costs money. So we need money to set up community projects. And trust me, I've tried. I've tried with the limited amount of income that I make to set up these community projects in my town.

And we've set them up. But then to manage them and actually let them become successful so they bring an income, so that they start bringing abundance into the town, first with money, and then that money

keeps upgrading and improving. That is where it normally falls down because as an individual like myself, I end up running out of money every time we start to get out of the starting blocks.

So this is why I need to bring it back to the political platform. And it became very clear to me because in 2014, the Ubuntu Party ran as a political party, and I ran for president in South Africa. We ended up with a million followers. That is a large number of followers.

DW: That is a large number.

MT: I know this because I have 800,000 names and cellphone numbers on my laptop of people that responded with SMS messages saying, we love Ubuntu. We support Ubuntu. So I'm not just making this number up. I can show this.

DW: What's the total population of South Africa?

MT: Well, it's about 55 million, about 20 million voters. So we had about a million followers into the elections. But this is when we learned how crooked and predetermined the outcome is. But it was very important for us to go that route, to learn and become wise from the process, to see what the next step is going to be. And that's exactly what we found.

And I found the following-- we didn't even smell the inside of Parliament, although we should have had at least four seats or five seats. And so we ended up with about 5,300 votes. So you need 50,000 votes to get a seat in Parliament.

But what that made me realize is that where the real power lies is at municipal level, at community level, in the towns. And one mayor, one elected Ubuntu mayor, will be infinitely more effective and powerful than one elected member of Parliament. Because if I win and get elected as mayor, I can implement all these philosophies in my town virtually overnight.

Why? Because I get money from government. And I can put the money that comes into the municipality-- I can put that money into all these community projects. They'll then spark the growth of the community projects, and it just expands very, very quickly, from there. So what we're now--

DW: What if you have this big factory that's dumping industrial emissions into your river? And they got lobbyists and lawyers and all this money behind them. And this community is getting some money.

But they want to stop the pollution from flowing down their river. What are they going to do about that?

MT: OK. I'm going to come to that. I'm going to come to that because you'll actually get the answer yourself once I've taken you through this little process.

DW: OK.

MT: You'll be able to answer that yourself. So we basically now are going-- in 2016, we have the South African local municipal elections. And I'm using this as the catalyst, the spearhead for the global Ubuntu movement. Now, we've got members in more than 200 countries. I didn't even know there were 200 countries. But when I read the list of where people have signed up from, I'm like, what? It's amazing.

So we need to raise enough funds to contest successfully the local municipal election. Our aim, our strategy is to go after the 12 smallest municipalities. It's the Achilles heel approach. Because if we win one municipality and the four or five towns who make up that municipality, we will shut down the capitalist system and implement this Ubuntu system, contributionism system, virtually overnight. It will be the first domino to fall because once you start implementing this, it is impossible for a capitalist model to function any way within the proximity of this kind of model.

And the whole philosophy is based on win one small town. And this is why I say we can bring down the global money banking Cabal with one small town. Doesn't matter what country it is. One little town can bring down the whole banking and money control system of humanity and free us all.

That's how critical and simple it is. Win one small town, implement these philosophies, implement the community projects. And our main promise to the people for this election is free electricity for all. You all know that free electricity is available. Alternative electricity devices and supplies are available. That's part of the control system of capitalism has kept that away from us.

We will implement a very simple electricity supply for our town. And that will be the foundation to unite the people. Everybody gets free electricity in return for giving three hours a week to one of the community projects. And this way, everybody has three hours a week. You don't have to give up your job. You can still carry on the system as it is today while we start creating this abundance.

What we did in Australia just recently, in Byron Bay, there was a statistician there. And he did a calculation. And this is what he said. A small town-- because I use our town of 5,000 people as an example. 5,000 people, three hours a week, it's 15,000 hours of labor a week. Right? Need I say more?

That's just working collaborative. No more competition. Let's unite and collaborate and cooperate. 15,000 hours of labor a week. He did the numbers, and he said one year of people contributing three hours a week in this system, one year of this is equivalent to 31 years of people working eight hours a day as slaves in the current system. One year to 31 years. Those are the ratios.

So within a very short space of time, we'll turn out community into a community of unimaginable abundance. We'll have so much food. And then you decide how this unfolds. So we've got a plan of action that then creates a supply. So what we've done, in essence, the moment you start creating all this food and whatever-- furniture, clothes, bread, shoes, whatever, technology, computers-- you open up your science laboratories to researchers and medical people to come and find the cure for all disease and share it with the world.

So you invite the scientists to develop ways to get rid of the pollution in the river. So there's your answer for how you're going to deal with the pollution. You know that we can deal with a nuclear fallout within a week if you get the right minds in there. Right?

DW: Well in America, something like this happened after the Depression, and again after World War II and during World War II, where these large social causes mobilized the public, and they got involved in public works projects. And people were really inspired. And that was the last time that America really had a manufacturing boom. And then when we expect everybody else to do all the work for us and we're going to import everything, it crumbles from the inside.

MT: What it does to our town and our community, instantly turns into an attraction for anyone who wants to create, invent, and use their skills to serve themselves and the rest of the people. So it'll invite everybody. And it also shows how this contributionism model is an inclusive model. It doesn't exclude anyone. All you have to do is make your business, your company part of the community projects. What is the benefit to you? Free labor, free electricity, free components-- because if we don't have the components, we set up a community project to make the components. So this is how it grows.

And you retain one third of whatever we produce and sell. And the other two thirds go to the community. So the answer to every time I approach an industrialist or a farmer, it works on all levels-- with farmers, with industrialists, manufacturing, anything. One third goes to the business, and the other two thirds go to the community. The answer is not, let's negotiate. The answer is, when can we start. Really.

CG: Well, I can tell you, everything you've said pretty much interweaves with what the Alliance has been saying, what the Blue Avians said in their message. And what they've said is that this is the wave of the future. And this is something that I strongly feel-- from these sources pointing your movement out directly, I think this is something that we all need to look deeply into, educate ourselves about, and in whatever way we can contribute, contribute to.

And I've really enjoyed hearing this deeper explanation. I've learned a lot more about the movement. I'd just heard little bits and pieces through my sources. And this is incredible. And I really do see it as no other alternative but the wave of the future.

MT: Well, thanks, **Corey**. And I just want to come back, what I said right upfront. The transition from where we are now to living in this world of abundance is so simple. It is so much simpler than most of us could have ever imagined. But most of us keep tripping ourselves up because that's how we've been brought up.

Things are difficult. You've got to work hard. No. Put that out of your mind. We're going to rid ourselves of the money. We're going to create a beautiful future of abundance for ourselves. Let's start visualizing it, and let's see this as a solution. It's so simple.

I'm not in charge of it. Every community's in charge of their own lot, their own future, their own abundance.

DW: Let's challenge the viewer out there to get involved somehow. How does the person watching this, if they're inspired by what you've said, how would they get involved, take this to the next level?

MT: Thanks, **David**. Well, first of all, go onto the website. Join us. Go to ubuntuparty.org.za and join us there where it says "Join Us." And then read as much as you can. Get a copy of the Ubuntu book because that's a means of funding for us. That'll help us.

And then if you have a way of funding, if you're a closet multimillionaire and you want to help this because it resonates with you, we need your help. We're not going to do this without money. Because remember, the system has been set up so that money keeps destroying any opposition. And I feel it month in, month out. It's a constant struggle. So we need financial support.

So if you can help us financially to get into the selection and make it a success, that's what we need from you. You can do that on the website, and there's a donate button there.

DW: Now, are those grants? Or would the investor be able to get a return on the investment?

MT: Unfortunately, this is not a return. The return will be in the result of the election, where they will know in their heart that they did something that benefits humanity into the future. There's very little I can offer them other than my gratitude.

DW: But there are also tax write-offs. I mean, people would either give the money to the government in taxes, or they could do something like this as a nonprofit.

MT: Yeah. And we do have a nonprofit company that will be receiving this money. We've just set it up. It's called Ubuntu Planets.

DW: So there's people that have all this money that they would need to give to the government unless they can put it in a nonprofit. So that'd be perfect.

CG: And it's also an investment in the future, an investment in humanity and changing the world.

DW: Absolutely.

MT: And like I said, it's one small town. Just see this as your support of this spearhead that's going to pierce the veil of control of humanity for thousands of years. We're going to burst through that and open it up.

DW: So you were saying Ubuntu Planet?

MT: Ubuntu Planet is the new nonprofit company that we created for this. So Ubuntu Planet will be the vehicle that gets the funds and from there will then distribute it to the Ubuntu Party, the political party,

where it needs it. I know that in the USA, apparently, nonprofit companies aren't allowed to fund political parties. But that doesn't apply in South Africa.

DW: All right. So that's been some pretty mind-blowing information. I'm looking forward to hearing a lot more from **Michael** Tellingier coming up. I think this is very exciting. And as always, I thank you for watching "[Cosmic Disclosure](#)." We're co-creating a new future together.

Cosmic Disclosure: Super Earth

Season 4, Episode 1

David Wilcock: All right. Welcome to "[Cosmic Disclosure](#)." I'm your host, **David Wilcock** and I'm here with **Corey Goode**. And in this episode, we're going to start exploring some of the cosmic history of our solar system. So **Corey**, welcome to the show.

Corey Goode: Thank you.

David: So, I had heard about this Super Earth well before you ever had anything to say about it. It is mentioned in "The Law of One" as the planet Maldek. And way back when I first got into all this stuff, Richard C. Hoagland, and all the years I spent studying his material from 1993, when I read "Monuments of Mars", he was very big on the idea that the Asteroid Belt was not something that would normally appear in a solar system.



So when we see these asteroids, your direct knowledge is that we're seeing a debris field of a ruined planet?

Corey: Yes.

David: And Hoagland's top insider told me about something called Brilliant Pebbles. And when you and I started talking, there was audible shock from you on Skype . . .

Corey: Yes.

David: . . . when I mentioned Brilliant Pebbles to you.

Corey: Right.

David: And why was that?

Corey: Because I had heard of that program.

David: So I can kick in some of what I heard about it, but this is mostly about getting you to talk, so what did you hear about Brilliant Pebbles.

Corey: A computer and mathematical program that was rebuilding, from what they've studied of orbits in the Asteroid Belt, to calculate back the size and density of what it used to be.

David: What did it used to be?

Corey: The Asteroid Belt.

David: And what was the conclusion of this program?

Corey: That it was a planet at one time.

David: Okay. Now, I got this information from Hoagland's top insider, who I refer to as Bruce. It's not his real name. And one of the things he said was that they were releasing rocks in space, and then charting how they moved, and using that to build very advanced computer models of how this would work.

Corey: The Asteroid Belt has been studied for a long time. It's been mined, and they know it very well. So they took all of that telemetry and found a way to trace back what it would have looked like at a certain time period.

David: I think you've mentioned this before on the show, but it's good to repeat it right now. They were able to find different aspects of a planet in the asteroids?

Corey: Different strata. Yes.

David: So like the mantle, the core, the crust - these different things. They were able to see those different parts?

Corey: Right. And find different parts of the crust that had different mineral deposits that were even easier to get to than mineral deposits here on Earth.

David: When they went out and looked at these asteroids, they weren't just fresh asteroids, right? They had been, in some cases, mined thoroughly?

Corey: Right.

David: And there was a lot of ancient stuff on them?

Corey: Right.

David: Okay. So one of the other things that we have to talk about with the Super Earth is Hoagland's original guy, Dr. Thomas Van Flandern, who created what he called the Exploded Planet Hypothesis, or EPH. And this is very complex scientific data, which doesn't just include the asteroids. It also includes orbital perturbations in the solar system. And it includes all the comets.

So he was of the belief that the comets were the pieces of ocean from the planet that froze and turned into ice – water ice. And Van Flandern traced back all these comets and showed that they all actually . . . you dial it back, they all come to a single point of origin – like that was where the oceans went to.

So did you hear anything like that about the comets in Brilliant Pebbles?

Corey: There was ice in a certain region that came from the failed planet.

David: Hm. So that would've been the oceans that freeze-dried in space?

Corey: Right. The water from the planet.

David: Yeah. He was coming out of the military faction of the space program. And we're going to do a whole episode just on that. But he said that there's no extraterrestrials, that everything out there is ours, and it's just all advanced stuff that we know about. And that was another thing that was consistent with what you had heard.

Corey: Right.

David: So from this military perspective, they created a narrative about ancient extraterrestrials that came and went and are not here now, but then they had this whole story line built around it.

He didn't use the term "Ancient Builder race" that I remember. That was something I heard from you.

Corey: I was wondering if he was talking about the same.

David: But he did basically give me the same information. Now, this was a weird thing because when I first started talking to you, I had taken his testimony at face value as being accurate. And what he was told, for whatever level of compartmentalization he was in, was that this Ancient Builder race – and we'll just use that term, even though he didn't – the Ancient Builder race was five million years ago that all this stuff happened.

But your data on the Ancient Builder race is actually much older than that.

Corey: Right.

David: What was the actual data that you were given for when these Ancient Builder race artifacts appeared?

Corey: They were many tens of millions of years old – further back than any other type or signs of civilization or the newer ET groups that moved in - way past.

David: Did they have any ability to try to get a specific time or was it just that it was countless millions of years old?

Corey: There is so very little that was known about them. When they would find their structures, every time they would find the structures that were especially exposed, there were places that obviously had glyphs on them, but had been wiped clean by other races that had come.

So there was a lot of mythology among all the different groups that were creating a lot of mythology about them. But when it came down to brass tacks, very little was known about them - a lot of mystery.

David: Well, you had mentioned before, a technology of chronological timing that had been used for apparent Nazi remains on the moon and Mars, that they apparently had traveled back in time to create.

Corey: Right.

David: Does that technology work if you go back many millions of years or does it start to become a lot less accurate?

Corey: It works. It starts to become less accurate, and you get wider time frames.

David: Okay, so what Bruce had originally said, this was something very interesting because he told me it was an authorized disclosure from the United States government. That they didn't want to openly tell us this in like a major way, but that they were going to reach certain people who were seeding things into the UFO community and give them this information so that it became part of the public consciousness, and this was the first step.

Corey: This is how partial disclosure is going to work. They're going to tell people there's an atmosphere, a thin atmosphere on Pluto, that it has blue skies.

David: I just saw that last night.

Corey: Ha, ha.

David: And water.

Corey: There is liquid water on different planets. And then they're going to finally get to a point to where they get to do their narrative of disclosure, this slow, partial disclosure narrative. And then they're going to try that narrative to talk about this ancient ET race that used to be here that disappeared, that's very ancient. And that'll be probably the first bit of information people will get.

David: What kind of an effect are they thinking will happen if they say that there was an Ancient Builder race?

Corey: Well, they're prepping people for that already, with a lot of the ancient alien narrative that's going on.

David: So the polls are showing that even in the most traditional parts of America, the parts that would not be open to new information, we're looking at a 57% rate of acceptance of the existence of extraterrestrial life. So the old idea that, "Oh, 'War of the Worlds', it's all going to come crashing down. People will go into a panic." It's not going to happen if they tried to push out this narrative that some weird and interesting ancient race was here a long time ago.

Corey: Right. That's what they believe.

David: Is this Super Earth, do you think, is it going to be a major part of that first wave - talking about what the Asteroid Belt actually was before?

Corey: Yes. We'll probably hear some version of the history of our solar system that they 'learned'.



David: The idea that Hoagland put forward also included the notion that Mars was a watery planet that was actually a captured moon around this Super Earth – that both of them had oceans – and that this explosion that created the asteroids smashed into the side of Mars and caused excessive damage.

Was that consistent with what you heard from the smart glass pads, or however was that you came in contact with this information?

Corey: Yes, it was. It was postulated that Mars was most likely a moon of that Super Earth, and that it was damaged heavily on one side by massive impacts. And that most likely also stripped away its main atmosphere at the time, and it never recovered.

David: Never recovered?

Corey: Yeah. Never fully recovered to what it was before.

David: So these people that settled on the Super Earth . . . What we heard from Bruce was that he was told they don't know for sure, there's a lot of mystery, but that it was between 3 and 10 different extraterrestrial groups that came passing through and settled in our solar system.

He seemed to be thinking that whoever built all these ruins on all the different moons throughout our solar system was the same civilization that was on the Super Earth. But in light of what you shared from this Inner Earth Alliance, these people that were on the Super Earth do not appear to be the Ancient Builder race.

Corey: No. They're not the Ancient Builder race.

David: Okay.

Corey: And it seems that more recent information that I've gotten is telling us that the Earth received refugees, at different points in history, from a couple of different planets, at least, in our solar system where the planets failed and inhabitants left and came to Earth as refugees.

David: And that would be Mars and the Super Earth?

Corey: Yes.

David: And, again, that's completely consistent with what “The Law of One” actually says. They described the Super Earth - they call it Maldek – and they say that it blew up, I believe the figure they

give was 800,000 years ago.

So it's not exactly the same as the data that Brilliant Pebbles calculated, because when I spoke to this guy, Bruce, they were having it as about 500,000 years ago.

Corey: Right.

David: So is that what you saw in the Brilliant Pebbles data as well?

Corey: Right.

David: Okay. So another thing that was a big part of what Bruce shared with me, was that the people on the Super Earth were starting to build a ring around Saturn that was made of some sort of transparent aluminum alloy, and that if the ring had completed, they would have a pulse weapon that they could use to destroy other worlds.

He said that this weapon was attacked and destroyed at the same time the Super Earth was destroyed, and that the shattered remnants of it formed the rings of Saturn, and that they would go out there and study these pieces of these habitable . . . There were actual rooms people could live in inside this shattered ring that you could still go out and look at.

Did you encounter any of that information?

Corey: I encountered information about the rings being full of artifacts similar to that . . .

David: Oh.

Corey: . . . but I had not heard the information about it being a giant weapon.

David: What was the specific data that you got about that?

Corey: That it had the transparent alloy in it.

David: Really?

Corey: Yeah. But it had debris that looked like it was a part of structures.

David: Wow. Broken structures?

Corey: Yeah.

David: Very interesting.

Corey: Yeah. Destroyed.

David: Okay. Now I also want to point out that Bruce said that on the edge of the B-ring were the biggest chunks of the ring and that that's where it originally was. So let's take a look right now at a couple of images of these alleged ice crystals on the B-ring.

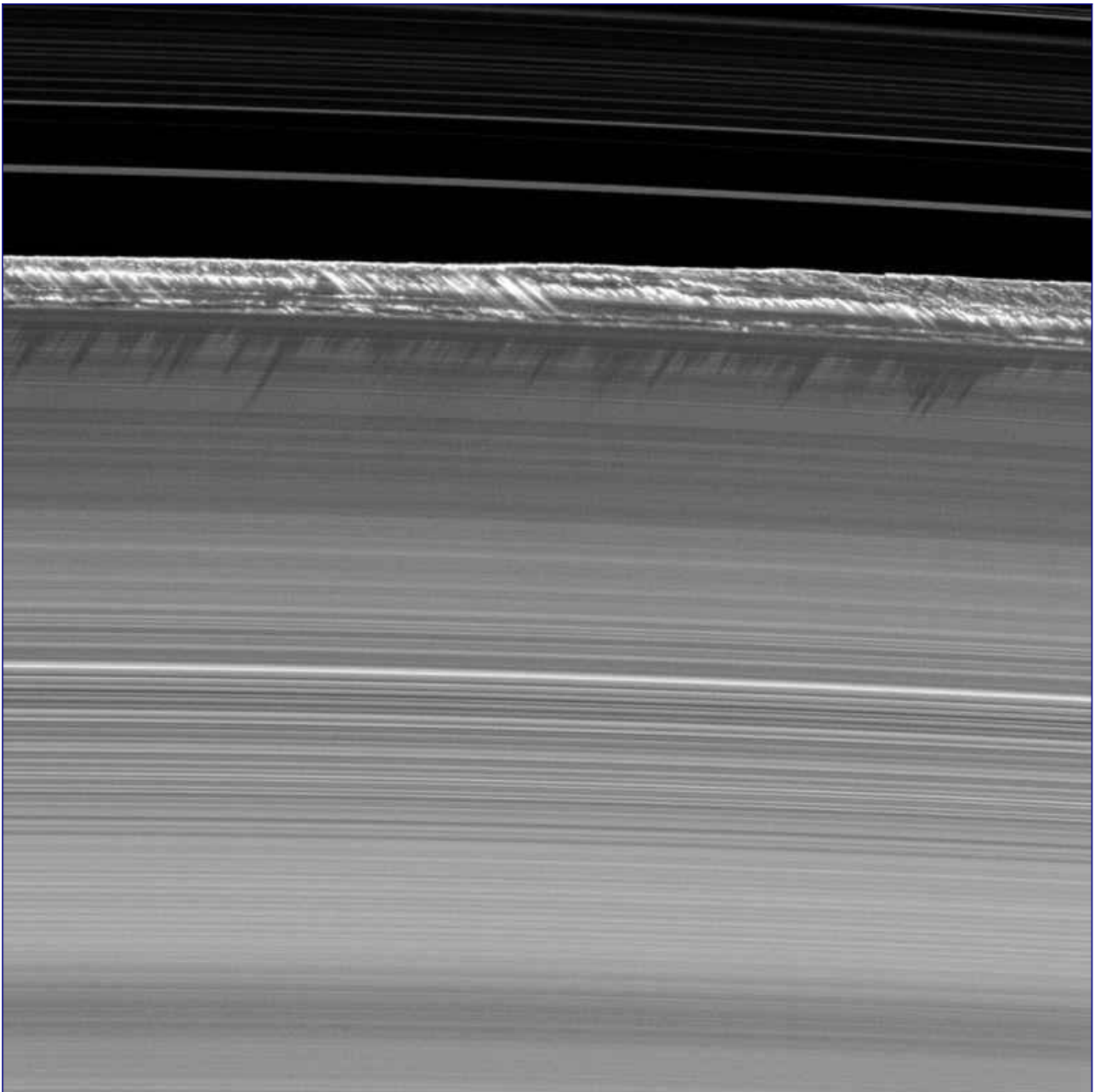

So if you're looking at this image, what you're seeing now is shadows that are cast, and as we zoom in on that, you see there are actually some pretty big chunks there. And those shadows actually cast on to the rings.

So what we heard from Bruce is that those alleged ice crystals are actually large pieces of rooms that people could live in, but these are people of an extreme height.

Now, this is another area where our data correlated. Bruce told me that these rooms were build for people who would be like 70 feet tall. Now, did you hear about there being ruins that were built for people of that type of size and stature?

Corey: Right. Yeah. We've talked about the different ruins being found with huge stone chairs and ceilings and doorways and table-type platforms that were obviously built for people much, much taller.

A lot of this ancient stuff that's found is also from the age of when there was a Super Earth and that kind of thing.

David: Okay. So there's a lot of cross-over.

Corey: Yeah, there's some crossover. Like the slabs that they have found of the Ancient Builder race, that are obviously not sarcophagus, but that people lay on for healing . . . When the humans would lay on them, they were a lot bigger than what was needed for a human to lay on.

David: Did they still work for healing?

Corey: Yes.

David: Really?

Corey: Uh hm.

David: Wow! The ring you never heard about, but you did hear about the shattered remains of something that was there?

Corey: Something, yeah.

David: Okay. So to continue with Bruce's story then, he said that whoever was on this Super Earth had been a very warlike species, and that they had gone out and they had really pissed off some people in other star systems. Did you hear that the people on the Super Earth had a technology that would allow them to have left the solar system and made war on other planets in other solar systems?

Corey: I was with scientific people that were looking at brass tacks, mostly scientific data. A lot of the information that is pouring out in this manner comes from different groups postulating from their root beliefs. There are different groups – secret Earth government syndicate groups that have different occulted beliefs that are trying all these different narratives. And there's really not that much known – I mean, fully known. But there are a lot of people trying to tie themselves to bloodlines from these planets or tie their mythology to these narratives, somehow.

So I just basically saw a lot of the scientific data and information and was not exposed to a whole lot of the theoretical.

David: Well, let's just extrapolate off of what you do know. Clearly, the people on the Super Earth had technology vastly in excess of what we have now.

Corey: Right.

David: Clearly, they had the ability to travel to another planet in the solar system, Saturn, and build this massive, massive, massive structure - I mean, the size of Saturn. To actually build a ring that's going to go two-thirds of the way around it is almost an unthinkable architectural achievement.

Corey: And the people in the Inner Earth Council stated that the different inhabitants of the planets in our solar system were extremely advanced technologically and extremely aggressive, and that they destroyed their civilizations and had to be relocated here as refugees by other ET races that came in.

David: And again, that's remarkably precisely what “The Law of One” says, which you hadn't read when this happened to you.

Corey: And still haven't. Ha, ha.

David: Ha, ha. So did this civilization that was on the Super Earth also settle Mars at the same time, if it had oceans and water?

Corey: The freshest information that I have is that these were two different groups that independently arose on these different planets, even though one may be considered a moon.

David: My personal speculation, based on trying to connect the dots and “The Law of One”, has been that Mars was heavily damaged by the explosion, but it wasn't completely damaged past the point where some type of life couldn't cling to it, even if maybe it involved a lot of underground bases that might have already been built before this happened.

Corey: Right.

David: Do you think that's possible?

Corey: Right. Right.

David: Okay.

Corey: But the surface, the previous ecosystem, was gone.

David: Right, but they could have had a vast underground infrastructure still in place.

Corey: Right. They were both advanced civilizations. Then, yeah, that would make sense.

David: Okay. So then the next thing was . . . and this is going to start to segue into what we're going to keep talking about in the next episode, the moon.

Instead of me blabbing my big mouth, let's keep it simple and have you tell us. Where did the moon come from? What the heck is going on with the moon - our Earth's moon?

Corey: Okay. According to the smart glass pads and what was reported, is that – and this is very controversial – that the moon arrived right around that also 500,000 year time period.

David: Arrived?

Corey: Arrived.

David: Okay. We're going to have to clarify what that means. Ha, ha.

Corey: Well, it arrived and formed some sort of tidal lock with the core of the Earth.

David: Oh. It arrived to the Earth.

Corey: To the Earth.

David: Okay.

Corey: And into an orbit that changes very little over time. And it came here from the explosion from the Super Earth.

David: It came here?

Corey: Right.

David: So it drifted over from the . . . As the Super Earth blasted, that the moon drifted and somehow got gravitationally captured by the Earth?

Corey: Some of the information was that it was under intelligent control, that it was artificial, and that it was bringing refugees here.

David: Some of the information?

Corey: Yeah.

David: So not all the information said the same thing?

Corey: Right. There was always opposing . . . Every time you had information, you had peer review type information – opposing view, why this could also mean this. That was always present. But you always had to read the bottom, and also, see that there were other views even though that was accepted by most of the peers.

David: Who were the peers?

Corey: Other scientists.

David: Which faction are we talking about? ICC?

Corey: Well, that would be most likely a joint . . . They all speak the same language, you know, agree on the same kind of stuff, but I don't know what standard it was, but they had a peer review process. It

wasn't just . . . One scientist couldn't just do an experiment and come to a conclusion and then put it in the database as fact. It had to go through a process as well.

David: And I think it's interesting for people to understand that they don't have all the answers. They're doing research, and they're trying to connect the dots with an archaeological expedition the same way that we would find an ancient city and dig it out, and then have to study the dots and study the writing and see if we can decipher the writing and all this kind of stuff.

Corey: Right. And they try to stay away from a lot of the mythology from the different groups. There's different groups that have a lot of different ideas about who all the different people were. There's different narratives from different groups.

David: Different extraterrestrial groups, you're saying?

Corey: The people that came from these planets that were destroyed, or lost their viability, that brought the refugees here, to the surface of our planet. Different groups have different descriptions of who these people are – different narratives that fit their belief systems.

David: Right. So there is no absolute standard of what actually happened that anybody can agree on at this point?

Corey: Right.

David: Well, that's frustrating, but I guess that's the result of if different people are saying different things, they can't all be right.

Corey: Right.

David: It's just like with religion.

Corey: Right.

David: And these are probably like religions, right?

Corey: Yes.

David: They are religious beliefs, in a sense.

Corey: Well, they are. All these different Earth government syndicates have different occultic roots. And they try to tie everything to their root occult beliefs and try to fit everything into the narrative of their beliefs.

David: So you were told by the people in the Inner Earth, based on their information – and they're right here in our backyard, so if they've been around as . . .

Corey: Under our backyard. Ha, ha.

David: Yeah, ha, ha. Some of them have been around for, as you were told, 17 to 19 million years.

Corey: 17 to 18 million.

David: 17 to 18. That's a long time.

Corey: Right.

David: That would mean that whatever happened to this Super Earth was long after they were here to witness whatever was taking place.

Corey: Correct.

David: So that's a very interesting perspective that they would have had. And you said in the previous episode that they were quite upset when refugees from the destroyed planets, both the Super Earth and Mars, were eventually transplanted and put on Earth.

Corey: Yes.

David: Why were they so unhappy about that?

Corey: Because this race was very aggressive and immediately began to assert itself on this planet and interbreed with the surface humans that were naturally from this planet – interbreed with each other, the other groups. And all ended up mixing together into a largely mixed race. They consider us a mixed human race on the surface.

David: And that aggressiveness is what makes us, to them, very dangerous.

Corey: Yes. Very unpredictable, dangerous.

David: One of the other things that Bruce said that I want to run by you is how . . . People are going to be saying – and we're going to get back to you talking about refugees, but how did this ring built around Saturn become a weapon? So I just want to explain what he said. What their intel told them.

Apparently, it's like Tesla's earthquake machine. If you go back and look at the Roman soldiers marching across a bridge, they had to march out of step. And if all the soldiers march at the same speed, the bridge starts to shake up and down and will eventually come apart.

Tesla's earthquake machine apparently involved a similar concept, where there's a rhythmic series of thumps and it builds up a resonance wave that eventually creates a massive earthquake.

So what he said was that the ring was designed to send pulses into Saturn, and those pulses would reflect back out to the ring and then back into the planet. And it would just build up this incredible charge. And then the ring could actually direct the beam to any location in three dimensional space that it wanted to go. They could triangulate the beam to basically any location.

Now, this sounds an awful lot like a movie that we all know and love, doesn't it?

Corey: Yeah.

David: One of the other things that Bruce said was that “Star Wars” was actually not just fiction - that it was a disclosure film. And when we start talking about a ring around Saturn that can be a planet-killing weapon, that sounds pretty familiar, doesn't it?

Corey: Right. There are a lot of different little caveats in “Star Wars”. Some of the ships from the Empire look very similar to the Dark Fleet vessels. Some of the concepts of The Force and the Dark Lord Siths, I've found to be consistent with some of these syndicate cults that Illuminati groups believe very strongly in. The dark part of the 'Source field': “May the Source be with you.” Ha, ha.

David: So in the next episode, these two definitely go together. We're going to get into what exactly happened with the moon and really delve into that story.

That's coming up next time here on “[Cosmic Disclosure](#)”. I'm your host, [David Wilcock](#), and I thank you for watching.

Cosmic Disclosure: Who Built the Moon?

Season 4, Episode 2

David Wilcock: Welcome to “[Cosmic Disclosure](#)”. I'm your host, **David Wilcock** and I'm here with **Corey Goode**. And in this episode, we're going to continue our discussion about the Super Earth and specifically the survivors of this terrible cataclysm that, according to multiple insiders who I've been in contact with and the information that **Corey** has gotten directly, was destroyed, and the fragments are now what we call the Asteroid Belt, which is parked between the planets Mars and Jupiter.

So this is going to be some very interesting information, stuff that many of us have wanted to know for so long, answering so many mysteries.

So, **Corey**, welcome back to the show.

Corey Goode: Thank you.

David: Now, I want to get into what Richard C. Hoagland's top insider, Bruce, was telling me about the nature of the civilization on the Super Earth. There are far too many correlations between what you saw on the smart glass pads and what he told me for it to be an accident that these things line up so well, in my opinion, and it was utterly mind-blowing for me when we first started talking in October of 2014 in detail how much of the stuff that he had said that you independently could verify from your own firsthand reports.

And, again, it's difficult to explain to people how much this happens when you start talking to different insiders. I was holding onto so much information that I had never put online so that people would trust me, so that I would continue to hear more.

Also, if it's going to get me killed, if it's going to get me in trouble, then I'm not going to put it out, whereas now that we've done this, it's time to just open the floodgates and let this stuff come out.

I want to go back now to what Bruce revealed about the actual race that was on the Super Earth in the first place.

First of all, he said that their height was 70 feet. Maybe this is because the planet is larger, so, therefore, the gravity is different, and the beings will be larger in correspondence with a larger planet. Would you say that's possible?

Corey: Yeah, different barometric pressure, all kinds of stuff. Yeah.

David: He said that this race was extremely technologically advanced. That was the data that they had concluded, and apparently they were playing around with transhumanism, which is the idea of integrating their human form – because it was a human form, it was just a giant human, 70 foot tall, 70 to 90 foot tall – integrating their human form into some kind of computer, Internet type of mainframe.

Corey: If they were tinkering around with something like that, I could see how that would lead to major problems.

David: Another piece of data that he seemed to be very convinced was solid, which I then got validated independently by the space program insider, Jacob, was that these people had long since evolved passed the need to use verbal communication, that the idea of speaking with their mouths was terribly slow. And he was specifically told that they developed some type of Internet, Wi-Fi-type of method of communication . . .

Corey: Light.

David: . . . that involved microfluctuations in the light that was on their faces, the skin pigment or something.

Corey: Micro . . . Like, we have micro-facial expressions. They would have micro-facial auric light. It was kind of like a light show.

David: So you did hear that?

Corey: Yeah, and they're not the only beings that do that. Some that communicate telepathically, there is a light, kind of an auric kind of play of light as well.

David: So you can confirm that some people are actually having cyborg-type of integration with their brain and the voltage on their skin so it's like a broadband Internet of data passing between two people when they look at each other?

Corey: I'm talking about . . . There are some advanced beings that, when they communicate, they have auric discharges in their body when they're connecting telepathically. There is more information. There is a huge exchange of information going on.

David: Is it possible that what Bruce said is true, that it could be entirely cybernetic, that it could be based on computer technology that wires into the brain, but then it triggers these fluctuations on the face?

Corey: Sure. If they were unwise enough to start wiring things into their neurological system, then, of course.

David: Well, that's exactly what he said they were doing, and he said that they had developed the ability to upload their actual consciousness.

Corey: Did they find bodies? Did they find bodies with this type of implants?

David: Apparently, that is part of it, and I'll get to that in a minute.

Corey: Okay.

David: But it's interesting, right, because he's hearing things for the first time, too. Nobody gets the full picture, right?

Corey: No.

David: That's part of the thing that's so frustrating about this is even at the level you were at, it's compartmentalized, and you don't get to hear all the data that's available.

Corey: Right, yeah. There are certain areas of the Lunar Operation Command I haven't been allowed past.

David: Okay, so we'll get to the bodies that they found in a little bit.

Corey: Okay.

David: Continuing the Bruce narrative, he said that they had a technology to be able to build bases inside these moons, and the technology involved something that was only the size of a baseball. And I guess the smaller size made it easier, and they could send this into the past, and then it would go into

the past, and it would build out with little nanite robots. They would dig their way through the moon and build the base.

And they would send it to the right time so that the base would be ready when they wanted it in their time. Have you heard of anything like that going on, anything like that being done?

Corey: Not sending, like, some sort of cube back . . . or some sort of sphere back in time that has nanites. That sounds like, you know, a lot of this AI kind of stuff.

David: Right, but it could be possible that a technology like that would have existed.

Corey: With all the things I have seen, I can't say that it's not.

David: Okay, so there actually is a little video that I want to show you right now of a robot that is just a piece of foil that they've already made that has a little processor chip on it, and it can carry things around. Let's take a look at this right now.

David: This video creeps me out because if you have these little guys that can just kind of flutter around and carry things and move things and build things, and if they then can develop a replicating ability where they can eat material – and this is what we already have right now. Imagine if our technology is 100 years more advanced, 1,000 years, 10,000 years more advanced. These type of nanites could go crazy, couldn't they?

Corey: Yeah, like I said. When it comes to nanites and artificial intelligence, there is a major red flag and issue that everyone in the Secret Space Program and also members of the Super Federation . . . there's a major problem, a major red flag with that technology.

David: Let's get into the moon now because that's the focus of this episode. What did you hear about the moon before they moved it to the Earth?

Corey: There were reports of them building bases so far deep that it came to this artificial material that made up the surface, or the fuselage, of what the moon was.

David: So are you saying that there is a fuselage in the center of the moon, and that they dug all the way down to it?

Corey: Personally, I don't know. There were two different reports, one of them saying that it was a hollowed-out moon that was used hastily, and another one that stated that it was a giant station that was built.

David: Did you ever personally hear anything suggesting that the Earth's moon is older than any of the other objects in the solar system?

Corey: I heard something along the lines either that it most likely didn't come from our solar system, or that it was too old for the items on the inner solar system, or something along those lines. I don't recall exactly the details, but there was something that didn't match about the geological age.

David: Okay. For what it's worth, the insider, Jacob, who we're not ever going to get on camera, what he told me was that the moon was portalled in to our solar system, that it's older than the planets in the solar system, from somewhere else, that these people on the Super Earth portalled it in at the last minute after having sent – and this now gets back to what Bruce said – that they sent this baseball-sized chunk of nanites to this old solar system somewhere way out where their enemies weren't looking, because they knew now that the enemies were coming in to destroy them.

They knew that their ring was going to be destroyed, and their planet was going to be destroyed. They had very little time. So the story that I heard, for what it's worth, is that this little baseball of nanites was sent to this other ancient solar system, that the moon was over there, that it went way back in time so their enemies wouldn't find it.

They built out the moon with the nanites, portalled it in, and then the elites of this planetary civilization on the Super Earth, at the very last minute, right before the planet blew up, they portalled themselves into what we call the moon. And this is where it gets really strange because what Bruce said is it was 12 to 16 billion of these people, 70 to 90 feet tall, that all portalled in to the moon.

And he said that they had firsthand knowledge that it was 20 to 40 miles deep of all built out intelligent habitations, rooms, the entire circumference, the entire sphericity of the moon on the inside, 20 to 40 miles deep, all just endless amounts of corridors that you could go through.

So it doesn't mean it's not true, . . .

Corey: Right.

David: . . . it just means that you personally didn't encounter it.

Corey: No.

David: But you did say that you heard that there were some kind of refugees from this catastrophic event, the destruction of the Super Earth, that were associated with the moon somehow.

Corey: Right, that arrived on the moon and came down to the Earth as refugees from one of the great cataclysms.

David: In Bruce's timeline, they spend a long time inside the moon before they actually go to the Earth, so let's just talk about this now. Did you hear that the people were inside the moon or on the surface of the moon when they fled the catastrophe?

Corey: They said they came in the moon.

David: In the moon?

Corey: Yeah.

David: That's consistent with what I heard, which was that the moon was getting battered by asteroids. Nobody would have been able to be safe or survive on the surface, so they had to be inside, and that they created a very highly advanced computer course to guide the moon into orbit around the Earth, specifically also because if they didn't find a planet to go around, they were going to get gravitationally captured by the sun, and they would be burned up in the sun.

And they programmed the orbit around the Earth to create tides and make the Earth into a much more habitable place to live, eventually. It wouldn't happen right away. So did you also hear that the moon going around the Earth led to the tides and made it a better place to live?

Corey: I know that it definitely brought a lot of changes, but there was life before.

David: Yeah, and he said that, too.

Corey: Right.

David: But the tides obviously could be causing a much more dynamic and diverse amount of life on Earth and make it so the oceans can get a lot larger, that kind of stuff.

Corey: Right.

David: What he was told was that the Earth was like a swamp, and that it was really hot, and that there were only shallow seas prior to this happening. Is that also something that you heard?

Corey: Well, I mean, I've heard basically the whole basic timeline geology, timeline of the Earth, that everyone else has heard. It's fairly consistent, except they leave out major and minor cataclysms that happened throughout the history of the Earth.

David: So did you hear that at one time the Earth was swampy and hot and only had shallow seas and wasn't very nice to live on?

Corey: It was much different. I didn't hear that it wasn't nice to live on.

David: Okay. So the next thing is he said that these people, these 12 to 16 billion people that portalled into the moon, which were like the elites of their society . . . I guess first of all, that little part of the story, that's consistent with the very common breakaway civilization narrative that you've encountered, right?

Corey: Right.

David: If you have a population of well over a trillion people, 12 to 16 billion is a very small number of them, and those people are going to save their own necks when they know that everybody else is doomed.

Corey: Right.

David: So what he said was that their intel was that the moon was pounded and that most of these people inside the moon all died in that initial event. So by the time the moon got to the Earth, it was very heavily damaged. Is that at all consistent with what you heard, that the moon took severe damage on the way in here?

Corey: Yes, and it's consistent with the way the damage is lined up on the moon when you look at it.

David: That I don't understand. Could you explain that?

Corey: There is one side of the moon that has quite a bit more damage, and it's kind of like what happened to Mars a little bit. One side of the moon has had quite a bit more damage to it compared to the other side. It's more pristine.

David: Well, now, right at the time that he was telling me this and saying it was an authorized disclosure, we start to see all these news reports where what they did is they take the moon, and they turn it on a slightly different angle and these seas, the mares as they're called, these dark areas, all form a square – a big giant square that covers almost the whole face of the moon. You just tilt it a little bit and you look at it, and it's a big giant square.

Corey, this stuff is mind-blowing. A geometric square should not exist on a natural satellite like that. What do you think we're seeing there? Why would they be telling us this?

Corey: It's a soft disclosure because at some point, if they're going to do a partial disclosure and let us know that there used to be ancient ETs in our solar system like we discussed before, then one of the things they're going to want to show us are there are a lot of surface ruins on the moon. And there are a lot of images we can show. There's a giant tower that's twisted and shattered, or twisted and bent over as though it was hit with a blast wave.

There are a lot of different artifacts from a wide range of ages. The moon is actually kind of a time capsule of an ancient time back when that Super Earth exploded and also of a time when there were battles between non-terrestrials and possibly even the Inner Earth groups that had been battling it out after these large changes occurred and these new refugees were brought to Earth. That was a very traumatic and huge time of change on our planet, and it happened in waves, these refugees that came.

David: When we go back to the movie “Alien” with Ridley Scott, there's this weird spaceman creature thing that's a giant in an extraterrestrial ancient ruin that they find, and then that story is followed up with “Prometheus”, the movie, where you have these giant, bald, very pale-skinned ETs with these black eyes.

I had a horrible time watching the movie. Some people really like it. I thought it was very traumatic to watch.

Corey: Yeah, yeah.

David: But do you think that this aggressive, angry entity – the giant - treating humanity as it is now, as an aberration, that we must be killed, that we were an accident, that this one guy from their civilization made us because he came to the Earth – and remember, he dissolves at the beginning – do you think that that is a statement of Cabal belief system about this Ancient Builder race and stuff?

Corey: Very much so. Yes.

David: Okay. Could you talk a little more about that for a second? What is the belief system?

Corey: Well, I've heard several different versions of their belief system, but basically their belief system is that this Ancient Builder race is their – one person called it a progenitor or their ancient bloodline. They are an elite. Their bloodline can be traced back to these ancient ET gods.

David: Why do the gods hate us then? Why are they trying to kill us?

Corey: Well, that fits in with their narrative of removing a certain amount of the population off the Earth because we're useless eaters or genetically impure. That fits into their mythos and sick religious dreams of the future of mankind. That's as they would like to see it.

David: So does a movie like “Prometheus”, where they go and find these very ancient ruins, is that like a religious sacrament for these people, that it's the closest they feel like they can get to seeing ruins, that maybe because they're in the Cabal on Earth they're not actually allowed to see? Are they told that these movies are showing them something that's very close to what it really looks like?

Corey: It depends. A lot of these people are out there doing scientific work, and then some of the people that are a part of these syndicate-type cults are going to come out there on, I guess, a pilgrimage kind of visit if they have a certain belief that this structure or this location means something more.

David: So they can go and take a trip out into the solar system and see this stuff in some cases?

Corey: Well, it depends on who it is.

David: Yeah. So they could take a tour of what for them would be like a religious pilgrimage site of their gods.

Corey: Well, yeah. Some of the people I described that have showed up to some of these meetings, they have off-world access, yes.

David: And if Jesus only happens 2,000 years ago, then for them that's just nothing, because this is much older and, for them, probably a lot more interesting.

Corey: Yeah, more . . . It's just tens and tens and tens of millions of years ago, some of it, . . .

David: Right.

Corey: . . . which is so far back that they can't accurately date it.

David: So you would agree then with Bruce's statement that . . . well, you didn't get the number, but 12 to 16 billion people, and that a lot of them died inside these caverns in the course of the moon coming to the Earth, . . .

Corey: I . . . I don't . . .

David: . . . that there was a massive damage.

Corey: There was a massive damage to the structure.

David: He also said that it was barely functional anymore at that point, that it made it to the Earth, but that a lot of it was really severely damaged, and it was nowhere near what it was built to do originally.

Corey: Yeah. All I know is that it made some sort of tidal lock orbit with the Earth, and now all sorts of ETs have bases there, including us. And there's a lot of mysteries inside the moon that I haven't been made privy to, and I'm told that it was some sort of escape pod-type thing or ark that brought refugees here from a huge cataclysm that made life on their planet impossible.

David: Okay. Have you heard that there is any type of AI in the moon or that there's a computer in the moon that could be artificially intelligent?

Corey: I know that they use holography, holograms, and other trickery to hide certain things on the moon.

David: What do you mean by that?

Corey: Holograms over certain areas of the surface . . .

David: Really?

Corey: . . . so it can't be seen with telescopes or when they're doing certain things, but I don't know of any type of AI or super type of computer that's being used at the core of the moon.

David: Well, this is something that several different other insiders independently confirmed, so I feel like it's pretty solid and likely.

So the next thing was he said that some of these people that were inside did manage to migrate to the surface, and at that time, they began building crystal domes out of this transparent aluminum stuff and having trees and civilization on the surface by having that pressurized area. So is that consistent with anything you heard, that there were actual crystal domes on the surface.

Corey: Right. There were plenty of ruins of that type of structure.

David: Did you personally witness those ruins?

Corey: Yes.

David: So what did you personally see as you flew around the moon?

Corey: There were domes, square buildings, towers, a lot of the stuff that was buried in, I guess, like, the regolith sand, the lunar sand.

David: Yeah.

Corey: But all that stuff is off limits to people who visit it, and they're of different eras, too, there is damage from different conflicts, and it's off limits to visit. It's held as a reminder of a different time when there was a certain amount of open war before they created these federations and treaties and before they had all of the diplomatic zones on the moon and all these diplomatic agreements that have prevented most of them from being in open war with each other, even though they have competing programs.

David: Well, let's real quickly take a look at some footage from the Disclosure Project – it's public domain, open source – of this particular witness who was shown pictures of what he called mushroom-shaped buildings and domes on the moon.

[Clip transcript]

Sgt. Wolfe: So he was showing me how all of this worked, and we walked over to one side of the lab, and he said, “By the way, we've discovered a base on the backside of the moon.” And I said, “Whose? What do you mean, whose?”

He said, “Yes, we've discovered a base on the back side of the moon.” And at that point, I became frightened, and I was a little terrified, thinking to myself that if anybody walks in the room now, I know we're in jeopardy. We're in trouble because he shouldn't be giving me this information.

I was fascinated by it, but I also knew that he was overstepping a boundary that he shouldn't be stepping over. And then he pulled out one of these mosaics and showed this base which had geometric shapes. There were towers. There were spherical buildings. There were very tall towers and things that looked somewhat like radar dishes, but they were large structures.

So I didn't say any more to him because I was concerned, again, that somebody was going to come in at any moment, would catch us having this conversation, and we would be in real trouble.

So that was the end of it right there. I didn't take it any further than that. You know, I just filed it away, but the interesting thing – every day that I went home, I would think to myself, “I can't wait to hear about this on the news”, you know? So I'd turn on the TV, and I'd look at the news to see if they were going to announce, “We've discovered a base on the back side of the moon”, being really naïve, you know? And, of course, here it is, thirty-some years later, and we still haven't heard about it.

[End of clip]

David: So when we include that testimony, we have independent verification of photographs of these things on the moon, and it's a very fascinating piece of collaborative data. But I just want to ask you a couple questions really quickly.

First of all, you said you saw glass-looking domes?

Corey: Yes.

David: Were they smashed? Was, like, part of the glass smashed out?

Corey: Yeah, they were not intact.

David: Okay. How thoroughly damaged did they look?

Corey: They looked very ancient and very damaged, very damaged.

David: How transparent were they still?

Corey: They weren't completely transparent.

David: So they were covered with some degree of dirt and sand or something?

Corey: Right.

David: You mentioned square buildings. Were the square buildings also made of this transparent material?

Corey: No, some of them looked like they were made of . . . They looked like they were made of some sort of either stone or concrete type of, like, created material.

David: What about the towers? Were the towers made of that glass-like stuff?

Corey: Yes, like tall, narrow, and then bending back and twisting, like they got hit with a blast wave.

David: Well, there's a lot more to discuss with this story, obviously, but I think the key here is that you did see that whatever this civilization was that built domes and developed on the surface of the moon, that they were very heavily attacked, right, because this damage was not something that would happen naturally. This was catastrophic damage.

Corey: It was catastrophic, but I did hear that there were a lot of smaller catastrophes that were happening. I mean, if you have a planet explode in your solar system, it's going to knock things around for a while, so there's going to be problems for a while.

David: That's a good point.

Corey: You know, there were problems going on for a while.

David: All right. Well, this has been a truly fascinating discussion. That's all the time we have for in this episode of "[Cosmic Disclosure](#)". My mind has been totally blown yet again, and I hope you're having the same experience there as you watch this. My name is [David Wilcock](#), and, as always, we thank you for watching.

Cosmic Disclosure: Age Regression and Time Travel Technology

Season 4, Episode 3

David Wilcock: Okay, welcome to “[Cosmic Disclosure](#)”. I'm your host, **David Wilcock** and I'm here with **Corey Goode**. And in this episode, we're going to get into some of the very interesting controversial material that has come up consistently in the feedback that you've given us in the discussion forums here on the Gaia website. And that is specifically this very bizarre notion of the elasticity of time and how it relates to age regression. So **Corey**, welcome back.

Corey Goode: Thank you.

David: So one of the things that people have stumbled over when they first look at your website is that you explain that you had a 20-year service record in the Space Program beginning In 1987, which would then lead them to believe that you would have been working until 2007, and at that time you came back to Earth.

But then the timeline doesn't seem to line up based on the other things that you said you did and when you said you did them.

Corey: Right.

David: So are we dealing with a technology that is more advanced than people are aware of in the conventional world?

Corey: Oh, absolutely. Ha. I mean, all of the technology that we're talking about in the Secret Space Program is far more advanced than most of them can imagine. The 20 and Back Program is a program that thousands of people have partaken in. And some of them have been people in the military . . .

David: What does 20 and Back mean, exactly?

Corey: You serve 20 years and come back to the original point in time you left. And there's plenty of people in the military that do this as well. They'll think they served their normal four or eight years in the military, when they volunteered and served in one of these above top secret programs for 20 years and were brought back to the point they agreed to do the program and then served out the rest of their agreement with whichever branch of the service they were in.

David: So what do you say to the person who believes that the technology that they can see in Internet searches represents the farthest that humanity has ever gone? How do you answer that person who just can't believe that there's anything more advanced than what they are aware of now?

Corey: They just have to look back at history. There's been so many times that we've been pretty sure that we knew everything, and then the government released information or a new technology, new space or aircraft, or a whistleblower comes forward like Snowden and releases information that people had talked about before and no one believed.

So if you think that everything that exists is on the Internet and all you've got to do is Google and find it, then you're living under a pretty large misconception.

David: Sure. Absolutely. Why would someone in the government want to keep the knowledge of a time travel-type technology secret? What's the reason for why they wouldn't just come out in the open and tell us that this is out there?

Corey: You can't talk about one advanced technology without revealing all the other advanced technologies. Well, that's letting the genie out of the bottle. And the major genie that they've been trying to keep in the bottle is not 'Yes, there are ETs', is 'Yes, there is free energy'. And free energy alone will collapse the global economy overnight – free energy devices.

David: Or maybe transform it. It would collapse the existing infrastructure or power structure.

Corey: Right. It would collapse their economic system, their Babylonian money-magic-control system overnight.

David: So let's just deal with some of the basics, and then we'll get a little more detailed and technical. And I remember when I first started talking to you about this, it really tripped me out, and I had a lot of questions to ask. So here's the first question: You go out for 20 years. They time travel you back to the point that you left. You return 20 years older than what you were when you left? Your body is 20 years older?

Corey: No. Your body . . . You're age regressed and time regressed.

David: Before that. Like let's say you're out in space, and you do your 20 years, and then they fly you back to the . . . Is it like the same room that you were in when it starts? They actually put you back in the exact same room?

Corey: They take you back to . . . Yes, you're taken back to the same point.

David: Okay. At first, when you return to that room, are you going to look 20 years older than you were when you left just a few minutes before?

Corey: No. No. When you're at the point to where they're delivering you back to your point of origin, you've already gone through the entire process of being age regressed, debriefed, blank slated, had a screen memory added if necessary, and then time regressed back to the point. And then they usually give you . . . The largest number of people have screen memories of portaling in and out of their bedrooms. And that was one of the screen memories that they had given me. But what they had done is used a technology to tell me to leave my house, and they picked me up in a van. So a lot of people still have that screen memory of thinking that a light opened up in their room, and they were portaled out of their room.

David: We discussed Voice of God technology. Is that the technology that would be used to get somebody to leave their house to go get picked up in the van, in this case?

Corey: Right. Right.

David: Okay. Okay, so you're saying that before you get returned to the room that you left from, you've already been through some sort of age regression procedure.

Corey: Right.

David: Let's just talk for a moment about what's happening there. So you're saying . . . Let's just walk through a hypothetical 20-year term of service. Did you only do one thing in your 20-year term of service in the Space Program?

Corey: No, I worked on several programs. I was transferred around to work on several programs during the . . . It was just a little over 20 years. And at the end of that 20 years, I was told, "You're time's up. It's time to go back home." Then they took . . . In my case, I was taken back to the LOC . . .

David: Wait a minute. Is it normal for people to have different transfers and not just all have the same job for the 20 years?

Corey: Yeah. Usually they work different . . . It's just like if you are in the service, you're going to be transferred around. You're going to develop skill sets. Their skill sets are going to evolve. And you're not usually going to be assigned the same duty on the same vessel for the entire time.

David: That makes sense, because otherwise people would get tired, burned out. So changing things up keeps it interesting.

Corey: Right. Things get boring and it's not as exciting as people think. It gets boring a lot, anyway.

David: Okay. So now you're saying that eventually they came to you and said that it was time to go back.

Corey: Right.

David: What was the last job that you had? What was your last assignment prior to them saying that?

Corey: It was one of the darker assignments that they had me working on that I don't like talking about very much.

David: Okay. So by that point you're probably quite happy to be getting a reprieve from it.

Corey: Yes.

David: Were you counting the years? Were you well aware of the 20 years and looking forward to it?

Corey: Yes.

David: Do people ask to get discharged early? Do they want to get out and see if there's a way they can get out?

Corey: That's not an option.

David: It's not an option. So people know not to even bother to ask.

Corey: Right. And if people were released for different reasons, I don't know about it.

David: If you tried to ask, if you say, "I really don't want to do this anymore," what's going to happen?

Corey: You were to follow orders. I never saw anyone that defied orders. It was very rigid, regimental situation to where you were seeing things done to other people that were unpleasant. You wanted to be not on the receiving side of unpleasant things. So you didn't rock the boat, so to speak. You just did what you were told.

David: But you said that it was a little more than 20 years before they told you your time was up. So was there . . .

Corey: Just barely.

David: Was there a period of time where you were like, "Oh, my god, it's been 20 years, and now they're not letting me go yet?"

Corey: No. There was a little delay before I started. I knew all about it ahead of time.

David: Oh, okay.

Corey: There was a little delay before I was assigned to the research vessel that they had me doing some other things.

David: So people have had trouble understanding what this age regression is. So let's walk through it now. They tell you you're done. You feel incredible relief. And what is the process? What is your discharge process? Let's just walk through that.

Corey: You sign papers.

David: First of all, can you tell us where you were? You were out in space somewhere, right?

Corey: Right. Well, they take you to the LOC – Lunar Operation Command – and you sign papers that you will not talk about anything, non-disclosures.

David: Non-disclosures.

Corey: You sign a bunch of papers. Then you go through a debrief that is an enhanced debrief to where they put you in an altered state and then debrief you over your entire service.

David: Is that some way that they're pulling information out of you almost like a computer hard drive, where they're hacking your thoughts? Or is this more of them getting you to verbally disclose your whole career history?

Corey: You're verbally disclosing and confirming information they already know while you're also hooked up to electronics that are monitoring and recording telemetry.

David: What's the telemetry that they're getting? Why would they need to do that?

Corey: I don't know.

David: Is it like lie detecting?

Corey: I don't know. It was for their use.

David: Okay, so you kind of do a life review, and how extensive does it have to be? Do you have to talk through year by year, experience by experience, or just highlights?

Corey: It was fairly detailed unless they saw something they wanted to focus on and talk about. It was at the discretion of the person doing the debrief.

David: In your own case, was there anything that they felt the need to focus on and spend more time talking about?

Corey: Yes.

David: Stuff that you don't want to tell us?

Corey: Yeah.

David: Okay. So you go through this debrief process. How long does it take? In psychological time, how long did it feel like it took?

Corey: The debrief . . . They were also doing blood tests, doing different things like that. It was probably two or three days spent at the LOC throughout the debrief and waiting process. There were other people going through it as well.

David: Were you in the same room each time? Was it all in one room while you were actually going through the debriefing?

Corey: The debriefing happened in one room, yes.

David: Okay.

Corey: But there were other people going through the same process at the same time you were.

David: In the room with you?

Corey: No.

David: So you had a private room.

Corey: Let's say there were 100 people that their time was up as well.

David: Okay.

Corey: We were all there as a group, and one at a time we were all going through the process of rotating through being debriefed, going through getting shots, blood samples, that kind of thing, going through the process.

David: So when you say the whole process was two or three days, that includes the social time talking to these 100 people while they're going through it one at a time?

Corey: Right.

David: And then the others are all hanging out?

Corey: Right. We were all kept on the base for that time period, and we were instructed not to talk to each other about logistical stuff. And when you're doing debriefs, you're not supposed to cross-pollinate or talk about . . .

David: How do you make conversation and small talk with somebody . . . you spend 20 years in space?

Corey: You get very good at it. You get very good at small talk.

David: Well, what would you talk about? Like stuff from before you went into space, like cultural stuff from when you were still on Earth?

Corey: No. You could talk about small talk stuff that happened in your daily life out there, but not operational information.

David: Nothing specific about your mission or what you were doing?

Corey: Right.

David: Were you in a private room at this point, or did you have to bunk with other people when you were sleeping?

Corey: In the LOC at one point, I was in a room with four people, but most of the time I was by myself.

David: What would this room look like? How big was it? Did it have any furniture?

Corey: Well, just four bunks. Four bunks. All the rooms were real small.

▫

David: Oh.

Corey: It's not like apartments or anything like that.

David: Any decor or anything that made it look nice? Or was it just very spartan?

Corey: No. Just four bunks, one above the other, real small, just big enough to get in, walk past each other sideways.

David: And you said it's not like "Star Trek: The Next Generation". It's conventional-looking doors, conventional rooms, conventional hallways.

Corey: Right.

David: No windows, I assume.

Corey: No.

David: Okay. So then you go through this debrief, and what happens next? What's the next part of the discharge?

Corey: The next part . . . They take you down to the lower floors where all the medical is, where they have a huge science and medical area to where they can repair injuries and just do all kinds of things. And they take you to the area to where they do the age regression.

David: After they've cleaned up your injuries or healed a bad knee or things like that?

Corey: No. They don't . . . No, that's . . . They don't do any of that.

David: But you had mentioned that they can do that.

Corey: Yes. That's where it's done.

David: But they're not doing that for you as part of the discharge?

Corey: Well, it's not needed because you're about to be regressed, age regressed, to where you were.

David: Okay.

Corey: Any scars you have, any tattoos you have, are gone.

David: Okay. Let's walk through this step by step. Do you go into a separate room? Is there like an age regression room?

Corey: Yes.

David: Okay. And so let's see what that looks like now. So you say it's a lower floor. You go in there, and is there a large area where you see all these different medical things happening? Are there like hallways with doors and rooms?

Corey: It's like your typical pre-op room. You go into . . . Like if you go into a hospital.

David: Okay.

Corey: You go in. You're sitting in a gurney. They come in. They talk to you, put you at ease. They tell you what's going to happen, that they're going to put you under anesthesia, that you're going to have to be kept totally static and in an induced coma for, I believe it was, nearly a two-week period.

David: My goodness.

Corey: And while you went through the process of them age regressing your body.

David: So you're in a private room now with a door that's closed?

Corey: No, this is like with the curtains.

David: Oh, wow! So there could be others from that group of 100 . . .

Corey: Right.

David: . . . that you're going to actually be only separated by curtains in this larger operating room-type looking area.

Corey: Right.

David: So there's like heart monitors and beeping machines and technology like that around?

Corey: No, they don't have to hook you up to that. Your telemetry's read remotely without having to touch you.

David: When you say you're on a gurney, it just looks like a hospital bed? It's not like some cool-looking tube or anything they stick you in?

Corey: No, it's just a hospital bed. Just a regular gurney.

David: Really?

Corey: Yeah.

David: But they say they're going to immobilize you?

Corey: Yes.

David: And did they give you a reason for why? Like, what happens if you're not immobilized?

Corey: They say that you have to be kept totally immobile during the process. You can't have any twitching or any moving throughout the entire process for it to happen.

David: Wouldn't your whole body go into atrophy if that happens?

Corey: No.

David: Wow! Okay. Did they let you know this is going to be told to you in advance, or do they save it until right before it's going to be done so you don't get paranoid about it?

Corey: No, you don't know anything about how the process works. I mean, they don't even tell you the details about how the process works. They just tell you, "Okay, we're about to administer medication. You'll start feeling sleepy. You'll be able to respond to our commands. Then we'll administer more medication. And then the next thing you know, you'll wake up, and it will all be over." And once they had administered the medication to where . . .

David: Do they have you catheterized so you can pee during these two weeks?

Corey: I was not catheterized.

David: Really?

Corey: Right.

David: Wow!

Corey: I was . . . Once they had me . . . I guess it was some sort of anti-anxiety or something that got you . . .

David: That makes sense.

Corey: You know, that got you real . . . just calm and kind of loopy. And then they flattened out the bed. They come in and they start bringing these foam, like a frame thing around your body. And they slide your arm in them and close things around your arm that will keep you from moving around.

▪

David: Like nylon straps or something?

Corey: Yeah, Velcro.

David: Yeah.

Corey: And they move you into another room. And this is where things really are hazy for me because I'm already . . .

David: Heavily drugged.

Corey: Heavily drugged. And they say that they're going to push the medication, the sleepy med, as they were putting up these white panels around my body. And I'm pretty sure they moved me over onto another bed from the gurney.

David: Did the panels look like they might be some type of technology, like an energy-beaming technology or something?

Corey: They just looked like white, maybe acrylic or plastic-looking panels around.

David: Okay. So nothing that special-looking.

Corey: Right. They start sticking needles and things in different parts of you for whatever reason, like in your thighs and in your body. And I faded out. And then at the end, you wake up, and you are now the age you were when you first arrived.

David: What did that feel like? When you first wake up, I mean, did you feel like you were coming out of a terrible, terrible hangover? Were you very groggy, sick?

Corey: It was just like coming out of . . . pretty much out of anesthesia when your surgery . . . You're just nauseated and disoriented, groggy, achy. You feel different. You're in a different body. At this point that they wanted to do another debrief.

David: How soon do you get to see a mirror?

Corey: I don't remember how soon after it was. I was in a . . . It seemed like they kept me kind of drugged up for a while. They immediately brought me into, like, another debriefing when I was still . . . when I was able to be more interactive and reminded me of all the things that I had signed. And it seemed like the environment and the people were different.

David: Were you aware of being on the LOC still? Is that what it seemed to be?

Corey: Yes.

David: Okay.

Corey: I was at the LOC still, but it was different. Everything was different.

David: Like just a different wing – a different part of the facility?

Corey: Everything just seemed . . . everything seemed different. Different people.

David: Do you think that possibly you were not in a different time?

Corey: Yes.

David: Okay.

Corey: Yeah. That's when they . . . Since you were already drugged, they wanted to do another debriefing, and then they would try to go through the blank slating and the screen memories. And they would try to do levels of screen memories to make you . . . They would wipe you to try to make you forget about the experience, and then give you screen memories to make you have conflicting memories about where you were and what happened, like give you memories of portaling to your room when you really walked back into your room. And it was just kind of a real kind of a mind screw.

David: So did it appear that they used the information that you gave in the first debrief where you sort of verbally talked through your whole experience? Does that become, like, their laundry list of things that they're going to now confabulate every one of those with fake memories and alternate stories so that nothing really lines up anymore? Is that the idea?

Corey: I'm not sure if they used that for that purpose. They keep a very detailed file on every person. So part of the debrief is they're verifying information and compiling information on their files, making sure they have correct information on personality profiles. And I'm sure that the first debrief was for several different reasons. But the whole part of them getting you back home is meant to be a whole groggy kind of process. I mean, if you've had major surgery and been driven home shortly after, like if you had a knee replacement or something like that, the whole thing is kind of a groggy kind of experience going back. And when the blank slating started to wear off, as it always did on me, the screen memories were there kind of at first. And I had memories of being portaled in and out of my room, but I had also memories of walking out to the car, out to the van, so I had kind of conflicting memories. And then the memories started kind of rushing back, immediately back, when I was that age.

David: Do you remember . . . I mean, obviously, if you're working out there for 20 years, you're going to be seeing yourself in the mirror.

Corey: Right.

David: Were there changes in your appearance over the course of 20 years? Was there a natural aging progression?

Corey: Yeah.

David: So if you're all drugged out and just out of it, when is the first chance that you have to really notice what this procedure has done to you, or the change that has occurred?

Corey: When you're back home the next morning, and you get up out of bed and you're still groggy, and you walk into the bathroom at your home and you look at yourself in the mirror, and you're confused.

David: What were the most notable changes to you in your appearance? What did you notice that was different? Or did the blank slating work so well at first that you thought that nothing had happened?

Corey: At first I was just really confused. And over weeks, the blank slating started to wear off, and I just immediately started having a lot of . . . The disturbing memories started coming back first, a lot of the very upsetting stuff. I was having a lot of problems with the memories. And then more of the organized, contiguous memories started to come flowing back.

David: When you say you were confused at first waking up, could you describe in a little more detail what you mean by the confusion? What was confusing?

Corey: I just didn't feel . . . I was confused. Something didn't feel right. I felt . . . Something felt out of place. I was nauseated. It felt like something had happened.

David: So something isn't connecting in your story here, which is, you're in the LOC. You wake up after the regression. You say that people and the facility looked different. So maybe it's 20 years back in the past now that you're in?

Corey: Right.

David: Okay. And you're all drugged out, and they give you another debrief. But then you're not amnesiac yet, right? You still remember what happened before? Or when you're under these drugs, are you just totally disoriented now?

Corey: I'm totally disoriented, but I still know where I am.

David: Okay.

Corey: And I basically know . . . I know everything, but I am blitzed out on drugs like they give you for surgery, anesthesia.

David: So what happens between the second debriefing, when you're blitzed out on drugs, and then you being at home? How do they get you home? You're on the LOC, and then what happens?

Corey: Well, I have a memory of walking back into my house, climbing back into bed and going to sleep. And then I had a separate memory of being portaled into my room, climbing into bed and going to sleep.

David: Ah.

Corey: And so there was a conflict there in the screen memory, and then the memory of walking up the front of the grass of my house and in through the front door and into my house, and then going straight to bed, climbing into bed. And then the other memory that I walked in through a portal into my room.

David: What happened . . . What's the last thing you remember in the second debrief? Did you end up losing consciousness again in the second debrief?

Corey: Yes. I remember going into the debrief and them starting to re-go over information, and then that's all I remembered.

David: So they may have given you more injections or some energetic something?

Corey: They did something.

David: Okay.

Corey: Yeah.

David: So by the time you then . . . So you have this very foggy memory that they confabulated. Maybe it was a portal or maybe you just walked into the house. But then it's when you wake up in bed that the procedure has now kind of run its full course, and you're waking up out of another very heavily drugged amnesia.

Corey: Wait. This is when I'm home now, right?

David: Yeah.

Corey: Yeah. Okay. I think I was confused there. Yeah. So when I wake up at home, I wake up and . . . you know, I'm at home. And I don't immediately have a memory of those other 20 years, but I am still kind of confused, and something feels not right. And something just didn't feel right from the beginning.

David: Now, you've said this in other episodes, but I think it's really important to mention it again in this one. They promise you, when you do this 20 and Back, that when you come back, you're going to have a real cushy salary and all these benefits for all this service that you've done.

Corey: Yeah, that you'll get free college, you'll have six figures a year, you'll live comfortably for the rest of your life. But they don't plan on honoring that, because they plan on erasing your memory and then just putting you off on your own and keeping you under observation.

David: Did you receive some form of payment while you were in the Space Program?

Corey: No.

David: Do various people have more money than others?

Corey: No, there's no money.

David: There's no money. So it's kind of like being a slave, or similar to, I guess, military service, where everybody basically just lives in the same bunks and has the same food. And you don't really get to have any possessions.

Corey: Everything's provided. No one even has photos from home. You don't have anything.

David: Are there any sentimental items you're allowed to have during the Space Program that you can bring from assignment to assignment? Like if there's an object that you decide you like, that you were able to maybe whittle something out of wood or something that you have for yourself? Are you able to keep that with you from assignment to assignment?

Corey: People had little things that they kept, but usually you just . . . you didn't have much room. You had a small little area to keep your couple changes of clothes, underwear, and the things that you needed, and that's all the room you really had.

David: That's your whole personal space other than the bed.

Corey: Space came at a premium, and there wasn't a whole lot of space for personal stuff. And there was no way to smuggle stuff from home, so people didn't have a secret deck of cards. They didn't have a picture of their mom and dad.

David: Can you remember a specific example of someone you knew who had a sentimental item?

Corey: There was, like, notes, letters written between people that ended up forming bonds and relationships, that kind of thing, that were in the program, but not any type of whittling or object like that.

David: Okay. So it wasn't like somebody would sculpt something or have an art project or anything like that.

Corey: Right.

David: No musical instruments.

Corey: No.

David: Okay. So if they're not honoring these contracts and not giving people free college and tuition and six-figure a year jobs, then it must be that this technology works really well on most people.

Corey: Yes. Yeah, it's like 3~5% of people that the blank slating memory wiping and screen memory technology just will not work on. They try and try and try and the technology will not work on [those people]. A lot of the other people, the technology will work on for many, many years and then start to break down. And it usually will not start to break down until after that 20-year period they served. Like let's say that I didn't regain my memories. I wasn't an intuitive empath. I was an engineer of some sort. Around 2008, after that 20-year period that I would have served, people all of a sudden will start . . . it'll start breaking down a little bit – some of the blank slating.

David: Is everyone kept on surveillance so that they can monitor if that starts to happen?

Corey: People are monitored, yeah. And as I said, when you're up there, as well, you're completely cut off from all information from the planet. So, you know no Internet, no radio, no TV. You can't come back with who won the basketball or football game information, who won the elections. You don't know any of that information when you come back.

David: You're totally isolated from any information on Earth.

Corey: Right.

David: Do they feel that would cause, like, a time paradox - some kind of problem - if that were to happen?

Corey: I would assume that is why. When you're in this type of service, you know, they will just tell you the rule. You don't get any type of communications from home. You don't get any type of news updates, and you don't get to say, "Why? Explain to me why. Give me the details. Please break it down for me." It's not that kind of a relationship you have with these people.

David: What is the year that you remember coming back? Or the splice point?

Corey: The splice point was just before I turned 17. So I was 16, just before I turned 17. And they returned me back . . . it was within a six minute or so window. So I was right close to 17 years old, right around 17-year-old mark.

David: Did you start to remember what you looked like when you were older?

Corey: When I started to get into my 20s, I started to really have . . . I really knew what I was going to look like at later ages. I mean, I had seen myself. As I was getting older, I had seen myself at that age before.

David: If someone forgets, what is going to be their subjective experience at the splice point? Is it going to be like they got sick and they're in bed for a few days, and like, man, I just feel horrible? What's their experience of the splice point?

Corey: They may think they have had a very strange dream or they had some night terrors. They may think they had a little bit of a flu or something and been nauseated, and something just didn't feel right.

David: How long does it take the body to recover from being two weeks in a coma immobile?

Corey: I was fine and ready to return to my life within, you know . . . the next couple of days. I was able to get my energy level back up and I was fine.

David: Are there any health complications from them doing this, or is it a really cool technology that just works great?

Corey: The people that have had this technology used on them report a lot of different neurological issues in their arms, in their hands, in their legs. Some of the people that spent a lot of time out will have issues with their eyes – cataracts, retina issues. But a lot of neurological issues.

David: And have you suffered those issues as well?

Corey: Yes.

David: So there's really no way to have a government program that you can appeal for medical benefits because this is all off the books and . . .

Corey: Yeah, you can't just go to the VA.

David: Unacknowledged. All right. Well, this has been really fascinating. I hope you've enjoyed it too. I wanted to get through the whole thing, so this is going to be extra length compared to a typical episode, but I think it was worth it to cover all of this at once. This is “[Cosmic Disclosure](#)”. I'm your host, [David Wilcock](#), and I thank you for watching.

[Cosmic Disclosure: Government Troll Data Center](#)

Season 4, Episode 4

[David Wilcock](#): Hello, I'm [David Wilcock](#), and welcome to another episode of “[Cosmic Disclosure](#)”. I'm here with **Corey Goode**, and in this episode we're going to get into government trolls, our friends we love to hate online who always are so willing to share their very, very negative and depraved opinions. But are they really just ordinary folks, or is there something more going on? So **Corey**, welcome to the program.

Corey Goode: Thank you.

David: I want to open this up by talking about a very, very bizarre television show that is now available. Anybody can watch it if they have a basic Netflix subscription. It's called “Ascension”. In the show “Ascension”, they describe a honeypot situation where, when people started to find out about this program that they're describing in the show, that there are places online that they designed where you will find that information. And they make it out like it's just a website, but then they're looking for people who actually are leaking real information. And that leads to a government hit job.

So is that aspect of what they say in the television show “Ascension”, is that real? Will they hang out information to see if a whistleblower shows up, and try to make them think that it's a trustworthy place to disclose data, only to find out that the trap is going to snap on them?

Corey: Yes. They use websites. They use people posting in forums, and they use established researchers who have been compromised by informants of their own. They've got the infiltration of this field down to a fine art, and they've had the infiltration of ufology in the esoteric community down from the beginning, since the early '50s.

David: How much of the information that people who are studying up on UFOs and reading online may be part of this type of program? Is this a fairly isolated phenomenon, or is it a fairly widespread phenomenon? How prevalent is disinformation in the UFO community?

Corey: It's incredible. It's heavily controlled, heavily manipulated information.

David: So what are we really looking at here? Does this mean that the average person, who feels like they've done a lot of homework and has really studied up and learned what there is to know about UFOs, are they polluted with an incredible amount of disinformation?

Corey: Oh, yes. I mean, I've talked to people who have angrily said, “I've done this for 40 years, 45 years, you know, 10, 15 years I've been studying this. I've been in the middle of it.” Their egos can't let them for a moment to believe that they have been tricked by information by these infiltrators.

David: Let's talk about the abduction issue for a moment. It's a very strange counterpoint between, for example, Dr. John Mack, who was a PhD psychiatrist from Harvard University – or it might have been MIT. I'm trying to remember. It's one of those two - the big Ivy Leagues in Massachusetts. Anyway, I think it's Harvard. Dr. John Mack, straight ahead mainstream psychiatrist with all kinds of published papers behind him, is interviewing people in a therapeutic context using hypnotherapy.

People get hypnotized, and they start to report extraterrestrial contact. And he writes a big, thick book just like mine – 500 page monster. You read John Mack's “Abduction”, and there's innumerable reports of people have been benevolent contact, spiritual experiences, mind-expanding experiences, prophecies of some sort of very positive change for humanity. And he said this seems to be a very consistent element of the contact experience.

Then, he allegedly slips on the ice and falls and hits his head, and he dies, right as UFOs are really starting to take off. But then you have almost every other alien abduction researcher completely divergent from what John Mack was saying – that abduction is this terrifying thing. It's only negative. They're bringing you up, they're taking genetic samples, they're terrorizing you, then they mind wipe you and send you back down.

So let's talk for a moment about the abduction narrative. Are these certain folks that are putting out very consistently negative information about abduction possibly on some sort of government payroll?

Corey: Not necessarily on a payroll, but are buying into a certain narrative that has been meticulously seeded with very believable information, and information that they know that a certain person is predisposed to want to accept.

David: Is it possible that there are people who are actually being paid to write books and pose as normal researchers?

Corey: Oh, yeah. That's definitely true.

David: Okay. I'm not going to name names, but I'm thinking of one very strongly right now.

Corey: Yeah, the most important tool to have is a psychological profile on a person. If you have a psychological profile on a person, you're able to then find ways to get into their life and manipulate them, manipulate their belief systems. You know what they're looking for, what their field of study, their interests are, and then you can put in people that have that information with the caveats that you've put on it, disinformation caveats, and then they jump on – or if they bite that information, then you are in with them and then they are now, I guess, parroting that information for you if you're a disinfo agent.

David: Well, let's talk about that psychological profile. You obviously know what you're talking about, but we don't. So let's just say you have someone on the Internet who has been targeted. What do you actually see, and what are they doing? What are they looking for?

Corey: Well, they have different types. They're going to break down your personality type.

David: What does that mean?

Corey: There are 16 main personality types. If you go and you take the test and you find out what you are, they have pages of pages that will describe your personality. Science has developed this personality typing over a long period of time.

David: I remember in college, I majored in psychology, there was something called the MMPI or the Minnesota Multiphasic Personality Inventory. It was a very, very complex, multiple choice test that did crank out something like you're describing at the end.

Corey: Right. This is very similar.

David: Yeah, okay.

Corey: They've had a lot of these that have evolved over time.

David: Okay.

Corey: So they want to find out your personality type. and most people think that everybody thinks the same way that you, that they, do, but we all approach things, think through things, differently. They want to get into your head and figure out how you think. Then, they're going to . . .

David: Is neuro linguistic programming part of this?

Corey: Yeah.

David: Okay. Then how does that factor in? Because I've heard that some people are more visual, some people are more auditory, some people are more . . . and you'll see people the way they look, like they'll move their hands, and where they look when they're talking about something has to do with what part of the brain they're accessing, that kind of thing.

Corey: Right. And they're going to need to know that type of information to know how best to target you. And then they're going to get as much information about the type of friends you keep, the type of content you watch on television, the type of information you follow on the Internet, the type of comments you make on social media – any and all information - they take, they put it together, and they have these different array of different types of psychiatrists that then pour over it and come out with a final psychological profile that says . . . It's a profile that an operative can look at and use to say: “This person will most likely behave this way in this scenario. Or if I want this person to behave this way, this scenario will most likely elicit this response.”

David: Well, I got pulled into jury duty a few times, and these attorneys end up asking everybody certain questions. And when they're trying to select a jury, obviously they want to pick jurors that they think are going to be more likely to win.

Corey: They're profiling you.

David: Yeah. So what is this . . . Is there a document? And is it like a stapled series of 8½ by 11 pages that you can flip through? How many . . .

Corey: Well, if you print it out.

David: Okay. So it's a written document.

Corey: Right. It's a typed document. It depends on what type of information they've been able to . . . If they've gotten into your medical records, they'll have medications that you're on. Sometimes if they want to get in and switch out your medications, that's handy to have. They want to know absolutely everything about you. So there will be medical information that's supposed to be HIPAA safe – everything that you can think of.

David: Well, one of the things we've heard over the years - I've been in this field a long time – when people are actually contacted by agents, which used to happen a lot more than it does now, and they actually do want to intimidate you, they will say things to you where you're like, “Wait a minute. I didn't tell anybody that. How the hell did you know that?”

Corey: Right.

David: So that gives them a lot of power. So they'll use all kinds of surveillance, and they want to have all these invasive personal details. So is it like an analysis of vulnerability? Is there a tactical breakdown of where somebody's vulnerabilities are? If you hit this button, you'll get them to break. If you hit this button, you can take away their money. If you hit this button, their relationship is going to fall apart. If you hit this button, their family's going to turn on them. If you hit this button, then this is where they go shopping and you could target their car while they're in the shopping mall?

Corey: Pretty much.

David: Wow! What's the tone in these documents? Is it sarcastic and mocking, or is it just very clinical and scientific?

Corey: It's clinical, scientific, matter-of-fact.

David: So it doesn't have a lot of nasty talking-down language or anything?

Corey: No.

David: Okay. So let's get into the core of what I wanted to speak about in this episode, which is people online are in discussion forums and we've been watching this happen for a long time. I first started to go online with a 14.4 kilobytes-per-second modem dial up, which I didn't even realize went that high. I only did it at 4.4, 4,400. "Oh, my gosh, it goes up to 14.4."

Corey: I remember.

David: And one of the first things I did is I went to Richard C. Hoagland's discussion forum on EnterpriseMission.com. And I'm saying, here's this guy coming out with this incredible stuff, that there's a monument on Mars.



David: It looks like a face, obviously artificial, with pyramids right nearby and a five-sided pyramid down at the bottom. NASA's got it on these photographs. There's all these geometric alignments that lead to a new physics of a tetrahedron inside a sphere. And this is where the Great Red Spot is on Jupiter, and this is where Hawaii is on Earth, et cetera, et cetera, et cetera. Wow!

And then I start reading this stuff, and why would these people be so angry and so aggressive? And over the years I started to notice, when you really get these nasty skeptics, they will never acknowledge that you made a point. They never change their mind. Their opinions never flex even slightly, and they just will constantly be on the attack.

And any rational, normal person, if you win a point, they will acknowledge and concede, “Yeah, yeah, that's true. Maybe I ought to be looking at this differently.” But these folks are like little fundamentalists, and all they do is they just caw and caw, like a raven, and they never get past their own opinion.

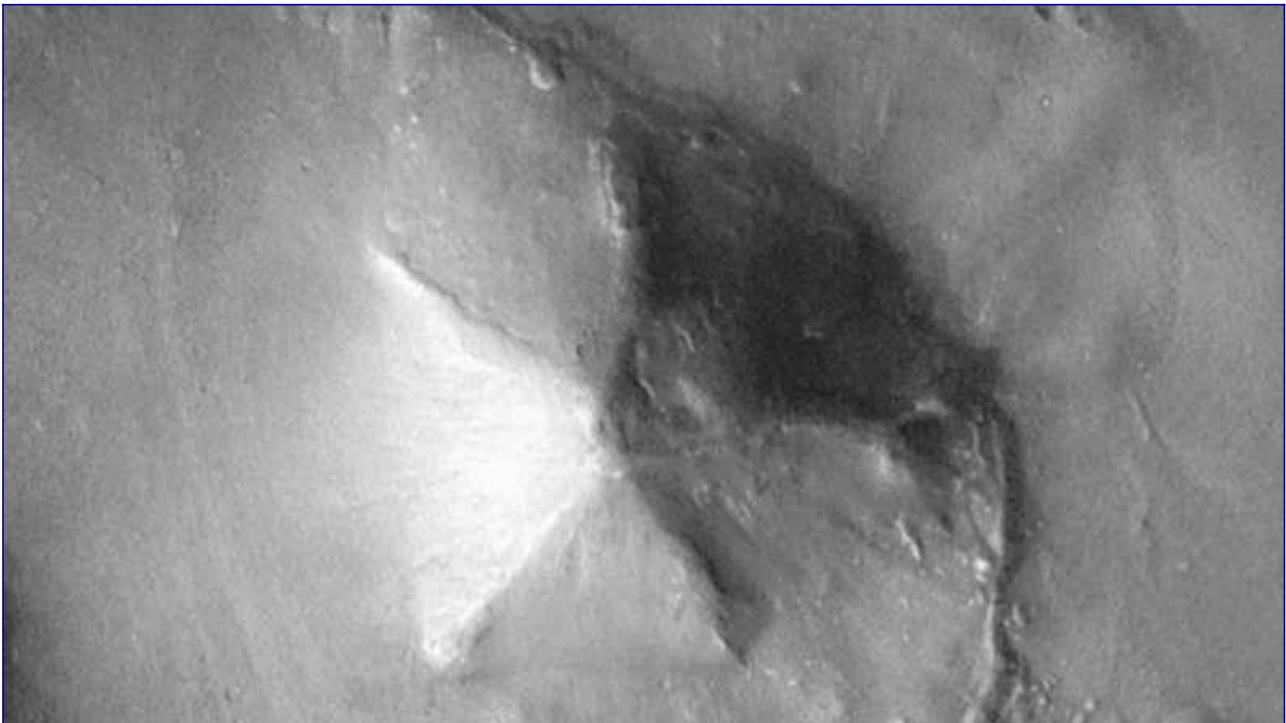

Corey: Yeah.

David: When people see folks like this online, are you saying that these people actually are being paid?

Corey: Not all. I mean, there's a phenomenon of anonymity, power. People feel powerful in anonymity on the Internet. They feel like, especially if they don't feel empowered in real life to stand up to people, they will overcompensate with the anonymity of the Internet. There are people that are narcissists and sociopaths that just get off on getting into circular debates.

David: Right.

Corey: So there is that. But I'm absolutely positive because I helped set up a government data center for, basically, government trolls.

David: You helped set it up?



Corey: Right, as an IT (I) set up a virtual data center to where each station had a post coming up, six monitors branching off, one computer station that ran VMWare workstation. And they'd pull up VMWare workstation, and they would pull up a virtual computer screen. It would be just like when you log on to your computer. You pull up a virtual machine, a virtual computer, but this computer could be on a server anywhere in the world and the IP address is anywhere, wherever that server is in the world.

So you can be sitting at this station and be pulling up these virtual machines from servers all over the world and make it look like you're in those locations from the IP address. And these people would have over a dozen different personalities that were created online, and had back stories, back information, have social media tied to them – very complex personalities set up with them.

And these operatives were normally what we call the “personality metamorph types”. It's a program of people that were sociopaths, really good liars and infiltrators, and were really sociopaths and were

really good at this job.

And they would sit down. Some of them would just troll around looking for information. Some of them would be given targets, go to certain Internet forums – esoteric Internet forums – log on with three or four user IDs, and sit there and cause a huge disruption if they saw a topic that was legit or something they didn't want to be talked about, cause a big disruption and sit there and have an argument with their self. And it looks like it's three or four people, problem people, having an argument, when it's really the same person sitting at a computer using virtual machines from all over the world and using fake personalities with user IDs.

David: Well, you have people that show up on my site and you get a whole bunch of them that all appear at once, and they start making all these anti-semitic comments. And then if we allow those to go through, somebody could then say, “Well, **David** is hosting anti-semitic content on his website.”

Corey: I delete those immediately off my site.

David: Yeah. What is the modus operandi of these attacks? I think what people are having a hard time understanding is, this is not a free, open debate. Are they trying to get people to doubt any of this information? Is that basically what it is? They want to make it seem like it's not credible?

Corey: They'll put out misinformation to cloudy the water and make people doubt or make people think there's been inconsistencies. They'll put out full disinformation contrary to it, or they will just make . . . they will sit there and bait people into debates that turn into circular debates that frustrate people to where people are triggered and don't want to come back, or they just say “pfft to the whole thing”. I mean, there's a whole bunch of different scenarios and tactics that they use to manipulate and play with people's minds.

And they even go as far . . . If there are certain people that are strong supporters of a certain topic that they don't like, they'll begin to harass people, stalk them online, and even form alliances with real people and manipulate them into causing problems for the person as well. So they will manipulate other people that are of a similar mind to cause problems, as well.

So they're not just manipulating the people they disagree with. They'll find other skeptics, feed them information for them to say, “Oh, okay. I knew it.” And then they will take that misinformation and

feed it further down the line. And I've seen a lot of that happening with bloggers that may have good intentions, but just have a certain point of view and then they receive information that they don't take the time to verify, and they just pass it along.

These days, honestly, anyone can open a blog or self-publish a book and or a YouTube channel. So a lot of these types of people can be compromised, as well.

David: Is it more useful to the Cabal if somebody gets into a highly charged emotional state, as opposed to if they're calm and rational?

Corey: Yes. Their goal is to throw you off. If you're calm, cool and collective and having a discussion in that matter, they'll try to get you into a circular debate until they trigger you and you lose it. And then they can say, "See, look at this person."

David: Well, and now you can ruin your whole career with one tweet.

Corey: Right.

David: Less than 140 characters can just destroy somebody.

Corey: Right. You can ruin your reputation.

David: And there's always a digital footprint of everything you say online, no matter how charged you are, if you get blind with rage or whatever.

Corey: Right. These people are very clever. A lot of them will approach you and be real friendly even, and you will feel an affinity towards them and then pfft, they'll turn on you and something will post some information you shared with them.

David: So like will they feed your ego and boost you up and make you feel really important?

Corey: Right. You've got to be very careful with people that are telling you you're special and boosting your ego, telling you how important your work is, and that kind of thing. It's nice to hear, but you've got to be careful.

David: I noticed at the very beginning of my career that some of the people who wrote me the most complex and complimentary emails, if I then answered them, that they could turn very quickly and go from really, really praising me to being extremely angry and upset and negative.

Corey: I have been shocked at the number of people that I thought were friendlies that turned on me [snaps fingers] because I didn't answer their Skype. I got busy and didn't answer their Skype in a certain amount of weeks or whatever, and then poof.

David: Right.

Corey: So, you know, some of it is just personality, people out there that are just being people, but the data centers that we set up were absolutely for the purpose of targeting people out there that were putting out information, and also to locate these people and report them up the chain so action could be taken against them.

David: Well, let's remind the viewer that Glenn Greenwald, after leaving "The Guardian", made his own website called "The Intercept". And there's a very complex series of Snowden documents that he's released on "The Intercept" documenting how they do this and showing flow charts and action plans of how these agents would attack this stuff, what things to say. And there were even examples in the documents, the Snowden documents, of like a seagull that's taken as it's flying fast so there's motion blur on the image of the body, and it kind of looks like a saucer.

Now, that picture is in there without any commentary, but it seems pretty clear, if you kind of connect the dots, that UFO forums were one of the things they were infiltrating.

Corey: Oh, yeah. The esoteric UFO forums and political and different non-governmental organization forums are their main targets.

David: Right before the Snowden documents came out, people might remember that there were other things starting to leak, and one of them was – this was just a few days before Snowden – that folks from the Tea Party were getting unnaturally audited at a much higher rate from the IRS than people that were not. Did they have the power to do stuff like that? Can they go after you through various corporate means, including taxes or maybe health insurance or your job?

Corey: Once you're reported up the chain and you're put on any number of lists, then you're open game to be targeted in any number of ways. If you're seen as a threat and you're put on one of these government threat lists, which undoubtedly you and I are definitely on, and a lot of people are on [the lists] that follow a lot of this information, especially if they're outspoken, they're definitely on lists, and things like that can occur.

David: When I first tried to open a bank account for my website as a company, I was told I had to create an LLC for tax purposes.

Corey: Yeah, I did too.

David: The bank, there was people that did a review before they'd give me the bank account, and this is just a simple bank account, nothing special. And the lady thought she was all smart and types in "[David Wilcock](#)" on Google, and the first thing that comes up below my name is "**David Wilcock** fraud" on Google. "Oh, well, he must be a fraud."

And then I went back to them and I said, "Do you realize that I've written two New York Times bestselling books, and I'm on the number-one rated show on History Channel?" "Ohh!"

And I said, "Look, tell her that everybody in my field . . . this is what happens. There's a lot of people out there that don't like controversial information." I just left it at that. So this stuff is real. People need to be aware. And were you just brought in for a week as a consultant for this job or was this just something you had for a longer period of time?

Corey: You're usually brought in to do virtualization. I was brought in to set up the virtual environment, to help the people with their workstations, get set up learning how to navigate their new virtual environment that was set up that me and some other people set up. And then after that, we moved on.

David: So you have a matrix of six screens, probably three on top, three on the bottom?

Corey: Right.

David: And then with the VMWare, each screen is a virtual machine in some different part . . .

Corey: Right.

David: . . . of the world so the IP address looks like they live in a different area?

Corey: Right.

David: And then they're working all these screens at the same time to have arguments with each other?

Corey: At times, yes. They'll sit there and argue with their self – with these alternate ego personalities – or they'll just be into multiple forums at the same time, causing problems, waiting for other people to respond, go to this one, say a few things, you know, kick the hornet's nest over here, go back to the other forum, hit refresh, see what happened – that kind of thing.

David: This is probably going to upset and annoy some people, make them pissed off. What can be done about this? Is maybe spreading the awareness and you coming forward with this, validating what the Snowden documents said on “The Intercept”, Glenn Greenwald's website? Is that part of the process?

And also, I guess, what's the best way to handle this if you think somebody is doing this online? Should you argue with them? Should you try to expose them?

Corey: Just being aware that that is occurring is the first step. Second step – and I've been guilty of it myself; it's hard not to sometimes – do not engage them. Ignore them. Pretend you didn't even see what they said. That drives them crazy. But just don't get into a circular debate. If you talk to a person and it looks like it's going into a circular debate, they're stuck. They're going to just reargue, reargue, reargue a moot point, then just move on.

David: What did they see that it is in the human psyche that makes us . . . We could get 100 positive emails, but we'll go for the one that's negative and focus in on that, or we'll see 100 positive discussions on a forum, and one person is a hater and we've got to attack that person? What is the vulnerability in us, and how can we heal that vulnerability so that we're not wanting to engage in these conflicts?

Corey: It is a part of human nature that we always focus on the negative. But also, it goes back to the personality profiles, and them knowing your weak spot. If they found that you don't like . . . If you're uncomfortable with the way your chin looks, they'll focus on your chin kind of a thing.

David: Do you think it's advisable for people to spend more time cultivating real friendships in the real world?

Corey: Yes.

David: Because I've never had somebody talk to me in person, in all the years I've done this, over 20 years . . . In all the years I've been doing this, I've never had somebody speak to me in person with

anywhere near the degree of disrespect that . . . If I read all the comments and emails that are out there per day, I could probably find 10 or 20 that are like that.

Corey: No one is the way they are in person when they're on the Internet. Even if they say, "I'm always this gruff. I don't care." Some of the people, yeah, I guess that's true, but for the most part, even the nicest old lady, when they have the anonymity of the Internet and their power to say whatever they want, they're going to bang out some stuff here and there. And the power of the anonymity of being on the Internet and being able to make comments that you wouldn't do face-to-face normally, it's not the best way to meet people.

I've known a lot of people that have met their soulmates on dating sites. I'm not going to knock that, but Internet forums are heavily, heavily, heavily compromised by both troubled people and paid government trolls. So I don't even go to them any more. They are extremely compromised.

David: If somebody does want to try to spread the truth and they feel like some people are not listening to the truth, what are some positive things people can do to help spread this message? Should they be fighting somebody if that person just doesn't get it? Should they try a little bit and then back off? What are some positive ways to try to combat this influence and get the truth out?

Corey: Well, speak to those who are willing to listen. You're not going to be able to convince someone, so move to those who seem interested and want to know more. Don't waste your time on the person that's going to just want to argue with you. It's a waste of time.

David: I think that's a good point for us to end this episode on. This is "[Cosmic Disclosure](#)". I'm your host, **David Wilcock**. We'll see you next time, and I thank you for watching.

[Cosmic Disclosure: Voice of God Technology](#)

Season 4, Episode 5

David Wilcock: All right. Welcome to "[Cosmic Disclosure](#)". I'm your host, **David Wilcock**. We're here with **Corey Goode**, and in this episode we're going to explore various aspects of a highly controversial topic, one that may be unsettling to you - the Voice of God. And as we've been sitting here meditating, getting ready to do this, I've been thinking about both the historic aspect of how some of these things have been done and then we're also going to tie in some very strange modern technology as well. So

this is going to be controversial. It may be upsetting, so viewer discretion is advised.

All right, **Corey**, welcome to the show.

Corey Goode: Thank you.

David: Now, when we go back to the history of the Cabal, it appears that we are dealing with the Egyptian mystery schools, Babylonian mystery schools, that were absorbed into the Roman Empire when Rome eventually conquered Egypt when they were quite weak. They absorbed the Library of Alexandria, they brought it to the Vatican, they relocated to England. And that is documented that Romans were coming to England around the beginning of the first millennium AD. They created Bath, which is a town in England, that still has the Roman baths in it. And it seems like that became their new base of operations for Europe.

Now, the religious wars that we know as the Crusades began around 1,000 A.D., and the Cabal begins to deal with a group known as the Assassins. Now, have you heard from your own background of any . . . Did you get any information about the idea of the use of drugs like hashish to train these men to become assassins?

Corey: The groups that we consider the Illuminati, or the occult syndicates, have been into mind control for millennia. And they use drugs, trauma, positive-negative reinforcement, all different types of methods that they've been doing for literally millennia.

David: Did you encounter any information suggesting that drugs and trauma were used all the way back, perhaps, to the Order of the Assassins so that someone could be brought into a state where they would be given verbal suggestions that they would not remember hearing later on but would then carry out what those commands were?

Corey: Yes. Using drugs, sexual abuse and other trauma on people when they were young to cause them to have segmented personalities is a very ancient way of creating people that they can create trigger words, or gateway words, or gatekeeper words, that can send them back into one personality or back to a docile personality and them having no memory of what they did - like "Manchurian Candidate" kind of thing. That's a very ancient type of tactic.

David: Well, right there you said something that a lot of people might not be aware of. They might think that MKUltra was only developed by Nazi Germany and is a recent thing that's only been a factor in world politics for maybe the last half century or so.

Corey: No.

David: So this is a very ancient technology.

Corey: Yeah. The root of everything that they did in MKUltra was very ancient and stuff that these Illuminati groups have been doing on their own family members for many, many hundreds of years. They were very familiar with them, knew they worked and decided to implement them in programs.

David: I met with a guy who was part of a family that had a great deal of money, and I was taken into a Masonic lodge that had many different lodges within it – a very large building. What you find out is that these guys are having to memorize incredibly long amounts of verbal information that they regurgitate, and they have to do it verbatim – incredibly complex, incredibly long.

Does someone need to be able to learn how to go into a state of hypnosis in order to have that type of performance of memory?

Corey: Well, yeah. They need to be able to affect your state of consciousness. That's a key factor.

David: So talk us through what you know about some of these secret societies and the ceremonies that are taking place. Is it intended to put you into a state of hypnosis? Do they do things that traumatize people and throw you into an altered consciousness?

Corey: Other than attempted recruitment of me by various members of secret societies, I have not been in these ceremonies. Where I come in, the knowledge I have, is the technologies they used to affect people remotely with technology – a kind of like radio technology or microwave-type technology.

They were flat panels, and they could focus on one person in a crowded room and send a signal that would vibrate their skull and the wet tissue of their brain. And the people would hear sounds or voices, not necessarily through their ear, but in their mind. And they called it the Voice of God technology.

David: What do you mean by a flat panel? What did it look like?

Corey: It looked like . . . Well, I mean, if you hand me that laptop.

David: Sure. Don't let the Cabal see the serial number, though. Ha, ha.

Corey: It would be not much different than that. It would be on a stand and have a cable coming from it that would go to a box. And then the box would have something that . . . a microphone that you would speak into, or there would be a preprogrammed audio signal that you would send.

And there was a third function. And this panel right here would be aimed at the person and it would shoot and focus on the single person. And it wasn't that much different in size than this.



Corey: And there was also what they called a data download function that would have a complex data download program that was created. The people that created them were called 'programmers', and they could create scenarios to give people visual, audio, and olfactory . . . They could smell, taste what they were programmed through what they were experiencing being stimulated in their brain through the technology. so they could give the people full auditory, visual and olfactory hallucinations.

David: Well, the high-level Illuminati insider, Jacob, who I had contact with for a long time . . . The reason why I brought up the Masonic stuff is he went into great detail with me about this. And he said that forcing people to memorize these very long passages of text is an excellent way to create wonderful hypnotic subjects where people will store incredible amounts of information that they're not consciously aware of.

So that technology involves a great deal of time, a lot of these ceremonies, but it also involves hypnosis and a lot of work. Now, this technology . . .

Corey: And a willing participant.

David: Sure. This technology you're describing . . . do you have to be in an altered state of consciousness for it to work?

Corey: No.

David: So it could theoretically be used on anybody.

Corey: It can be used on anybody. Yes. Early on, the technology they had worked only on extremely low frequency waves – ELF waves. And there's something called the blooming effect with both . . . It works like with your flashlight. When you turn on . . . Even with a narrow beam, you turn on a flashlight. The further away you stand from a wall, the wider the circle is on the wall. That's called the blooming effect, and that occurs with radio signals, and it occurs with even particle beams, light beams, lasers, you name it.

And also changes in the atmosphere can affect the blooming effect of different technologies.

David: Well, if **Pete** Peterson was here, he would immediately start talking about what he always calls phase conjugation and says that if you have two beams, that you can have the bloom be in a certain area, but that the beams will converge back into a point later on by aiming two or even three at the same source.

Corey: I know they moved to a different type of technology. This technology, depending on the model, was only useful . . . It's a line of sight technology. You had to be looking at the person and had to be within a certain amount of meters from the person to use.

The newer technology they can use from aircraft, low Earth orbit satellites and drones. And it's still line of sight, but it will penetrate certain materials like the roof of a house, depending on the materials used in the house.

Some people have used this certain type of insulation and stuff like that that have made it harder, but a

person can be sleeping in their bed, a drone can be flying around, and they can focus in on this person, seeing their heat signature, flip a switch on the data download, give the person a dream, give the person a complete false experience with . . .

David: I can understand the idea of you having a microphone and being able to speak into it and having that translate into auditory waves. Could you tell us a little more about how this data download actually works? You're saying people could get a dream that's beamed into them by Voice of God technology?

Corey: Not only that, but you could be sitting right here in front of me right now, and if you were to be targeted and they wanted you to see someone appear in the room and start talking to you, you would . . . and for the person to have a certain smell, you would see it. And this is not only used to target people, it was used to contact operatives in the field. Like if someone was behind enemy lines, they would send them information, send them a data download information about which escape route they should take to meet up with a rescue team, spies in the field to send them operational information on the fly.

It has a whole bunch of applications, but as this technology became very prevalent, a lot of black ops federal types, they started using them on their ex-wives' new boyfriends. They started targeting individuals, and it became an off-the-shelf technology for a lot of these groups.

David: Before I actually got my first insider disclosure and I knew that UFOs were real, there was a very creepy story from my family, because one of my mother's friends was friends with someone who had lived in Nevada, started to see flying craft or something - some points of light in the sky that were zipping around making non-Newtonian movements. And they think that because they were using binoculars that the glint of the lens was picked up by the craft.

But what ended up happening was shortly after this guy starts looking at these craft in the middle of nowhere with binoculars in the daytime, he starts hearing voices in his head, he starts feeling extreme senses of evil – like there's sounds of a monster or a large beast or footsteps or chains dragging, growls.

He would feel bizarre temperature changes in the room like it would get cold. And he started to have what appeared to be visual hallucinations in the room. We thought that they might have dosed him with LSD or something. We didn't really know what was going on, but this man became so scared that he just literally one day, not long after it started, just got into the car and drove away from the house and

never came back – didn't try to take any of his stuff with him, just fled in a total panic. And this is before I knew anything about UFOs.

That is just one example from my own history of a family story. So do you think it's possible that he was targeted? Does that sound consistent?

Corey: It sounds consistent. And the technology . . . They call it bioneural interfacing. And this is used often to contact people to convince them that they are in contact with a religious icon from their belief system, ascended masters, different ETs that they're channeling. And they're used to connect with these people and send them voice communication information, and also the download feature is used on them.

Now, the thing is that the download feature . . . If it's a prolonged use of the download feature, [it] absolutely causes paranoid schizophrenia in people who would otherwise never develop that disorder or have any type of chemical imbalance in their brains.

A person that would be totally normal, never has any problems, heavy exposure to this technology absolutely will cause paranoid schizophrenia in them.

David: Well, you've dropped kind of a bombshell here because this implies that some people out there who are representing themselves as channeling positive divine beings, could, in fact, be essentially remote controlled, and the messages that they are giving are straight out of the propaganda Rolodex of various alphabet soup agencies.

Corey: I know that is an absolute truth. That is happening. And this technology has also been used in warfare on the enemy, people being shown religious icons, being told the Great Caliphate or Allah is returning, throw down your weapons and give up. And it worked quite well.

It was developed to be used in tandem with some of the Blue Beam-type technology.

David: And for those who don't know what that is, why don't you say what that is.

Corey: Some of it was holographic, but a lot of technology, most of it . . . Some of it was ground-based, some space-based, to create visuals in the sky that would be seen by masses of people that would look three-dimensional and solid. And it's been used in small test cases with some of that

technology.

Most of the Blue Beam technology has been taken out and is not in use. But the Voice of God technology is very prevalent and used by a lot of different black ops groups.

David: Well, getting back to this Order of the Assassins thing for just a moment, it seems like the power of the drug to alter people's consciousness is key in getting people to do things that would be outside their normal ethical boundaries. Does this Voice of God technology also simplify that process? Is it possible to create various mental conditions in people that might in some cases resemble a drug-like state or intoxication?

Corey: Yes. They can trigger different parts of the brain to release different chemicals, cause depression. They can sometimes . . . It depends on how strong the person's will is, as well. If they want a person to do a bad act, they can just work on them over time with the technology.

If it then causes them to become chemically imbalanced, then so much the better for them and their goal. And if they start taking medications for depression or anxiety - a lot of these types of medications – that makes the technology more effective as well.

David: So you saw this technology being used in the field?

Corey: Yes.

David: What were some of the uses that you personally witnessed? What were some of the things that were done?

Corey: Contacting people that were getting in . . . splitting up groups, causing fragmentation in groups of people getting together to cause infighting.

David: Groups of people getting together for what?

Corey: To bring out information that they don't want or people that were getting together to talk about information they didn't want talked about. Being proactive to get in and cause the people to turn on each other – become paranoid.

Also, I saw it used to make people believe that they were in contact with ascended masters and ETs.

David: So you personally witnessed that being done.

Corey: Yes.

David: We have a list here of some of the names of this stuff that was on an article on www.prepareforchange.net that quoted from you recently. Obviously, one of them is the Voice of God, which you just mentioned. There's also V2K or Voice to Skull devices. Have you heard that term?

Corey: Right. It's the same stuff.

David: So how does the skull relate? Does it make the skull vibrate?

Corey: Right.

David: And that creates an acoustic frequency that people can hear?

Corey: Right. It causes an acoustic frequency and also they call it Voice to Skull. Some of them will cause the skull to vibrate and the small bones in the ear to vibrate.

David: Okay. There's also on this list remote behavioral influence technology. Is that a term that you are familiar with?

Corey: That's kind of an overall term that's like behavioral modification.

David: Okay. And then we have LRAD – Long-Range Acoustic Device.

Corey: Yeah.

David: So is that the panel that you were describing? Is that what it was called?

Corey: Right. It was just referred to as Voice of God, because people thought that they were hearing the voice of God or a divine voice.

David: And then the last one on the list is DARPA's sonic projectors.

Corey: I'm not familiar with that sound, but DARPA was . . . much of this technology was DARPA.

David: And for those who don't know, it's Defense Advanced Research Projects Agency?

Corey: Right.

David: Okay. Now, you may or may not be familiar with this. I know this is going to be very unnerving to some people, so I want to kick in something that you may or may not know, that if we had **Pete** Peterson here, he'd gladly go on in detail about. And I think it's important for some balance.

A couple of things: First of all, he said that approximately 18% to 25% of the people out there have extraterrestrial DNA in larger amounts and that those people . . . hardly any of this mind control technology works on them at all. Did you ever . . . You mentioned something about will. Did you encounter anything suggesting that certain people are less susceptible to this or that they could train themselves to be less susceptible to this somehow?

Corey: There were people that . . . We were told they had a stronger will, and they were less susceptible to it. And also because I knew – being intuitively empath trained – that people who have a more spiritual connection, they can be resistant to it, but at the same time, they can also be tricked a lot easier because a lot of them are overconfident, feeling that they're spiritually protected or that this couldn't happen to them.

And everyone that was involved in using this technology had to have the technology used on you so you would feel what it felt like in your skull. You'd feel it on your skull. Sometimes your skull would warm up, or you would feel it in your brain matter. But the sounds, you would hear it in your head as if you were thinking it yourself, but it would be a different voice.

So you had to be trained to know when the technology was being used on you.

David: What year do you think this was starting to be developed and actually implemented?

Corey: I know it was being used in the early '80s. I know.

David: Okay.

Corey: So I don't know how far back . . .

David: But it could definitely be maybe even 20, 30 years older than that?

Corey: Yeah, definitely. Yeah, it could be.

David: If a person watched this episode and thinks that what you described means that somebody could be beaming beams at people and turning them into remote controlled robots that will just do assassinations and kill on command, without any veto from their conscious mind, are those people correct, or do we always possess the power to veto these signals that are being beamed in? Do we have the free will to offset the message that is being offered to us?

Corey: We have the free will to offset the message. We have the power to reach out for help from people around us to ask for help. There is a group of people that call themselves 'targeted individuals' that I receive emails . . . that's why I'm being careful about how I answer this. They receive emails saying, "I'm a targeted individual. I'm being attacked by this type of technology all the time. I'm being told this information. I'm being led to do this or that. How do I make it stop? How do I make them stop targeting me? How, how, how . . ."

I don't know how to make them stop. I don't know how to make it stop.

David: Well, and the odd thing is that people that suffer from paranoid schizophrenia, it's these same symptoms that they're reporting.

Corey: Right. And this technology also, after prolonged exposure, absolutely causes paranoid schizophrenia.

David: But just to be clear again, I want to reiterate this: This cannot just turn the person sleeping next to you in bed into somebody who grabs a knife and plunges it into your heart.

Corey: No. No, you have . . .

David: It's not going to make somebody into an automated killer like MKUltra.

Corey: No. That takes years of conditioning and going through those types of programs. If you're a negative person and the type of person that's out to kill someone already, that's what's in your heart, then you can probably be triggered to do something like that.

If you're a good person, if you wouldn't normally do that kind of thing, then they're not going to be able to turn you against your values and make you do something like that.

David: So ultimately, this is only a suggestion. It's an influence that we can choose to listen to or to ignore.

Corey: Right.

David: Cool. All right. Well, that's some very intense stuff, but we're here to spread the truth, even if it's painful. And I hope that you can put this to good use in your own life.

This is "[Cosmic Disclosure](#)". I'm your host, [David Wilcock](#), and I thank you for watching.

Cosmic Disclosure: The Dark Fleet

Season 4, Episode 6

David Wilcock: Welcome to "[Cosmic Disclosure](#)". I'm your host, [David Wilcock](#), and we're here with **Corey Goode**. In previous episodes of this show, we have gone through the various factions of the Secret Space Program (SSP). We've covered this very extensive body of information, but one thing that we haven't gotten into that much, which we're going to do in this episode, is the faction called The Dark Fleet and the very shadowy humanoid reptilian extraterrestrial forces who are behind this.

Before we get into the bad guys, let's just talk about the benevolent forces that have stopped what seemed to be a train wreck in slow motion that was going on.

Who's out there that's got our back?

Corey Goode: Well, of course, we have the group that we've been talking about a lot, the Sphere Being Alliance, and they've moved in, and they've been here for quite some time, some number of decades at least. [They] started to come in at least in the '80s, but built up their numbers.

David: And why would you call them Sphere Beings?

Corey: They do not call themselves the Sphere Being Alliance. This is a term that the Secret Space Program and some of the secret Earth governments gave them. They call them the Sphere Being Alliance, because they were able to gather, through intelligence, that it was a group of beings that were associated with these giant spheres of three different sizes – the moon, Neptune and Jupiter, that were now in our solar system for reasons they were not sure . . . why they were there.

But this group was not making contact with them. They were ignoring their hailing attempts to communicate with them. So this is just what they named them early on.

David: You mentioned that there was a group called Solar Warden, which was the first real faction of the space program, and they acted sort of like the interplanetary police force . . .

Corey: Right.

David: . . . tracking any unauthorized entry or exits. You also mentioned the Interplanetary Corporate Conglomerate (ICC) is another faction that arose out of the military defense contractors. We've discussed Global Galactic League of Nations (GGLN), which was sort of a United Nations type of thing, maybe a carrot that was offered to various countries to stay quiet and feel like they're part of something really cool, and they're in this war against negative extraterrestrials.

You also mentioned a military faction, the Dark Fleet. Now, what is it about the Dark Fleet that earns the name "dark"?



Corey: A number of reasons. Well, in Black Ops, when there is a dark program, it is completely compartmentalized to where no one receives any intelligence. The other Secret Space Programs

received very little information about the Dark Fleet's mandate, what they were doing, what they were up to.

David: Really?

Corey: Their bases were completely autonomous. Other Secret Space Programs did not get to go to their bases. Their craft were of a different design usually.

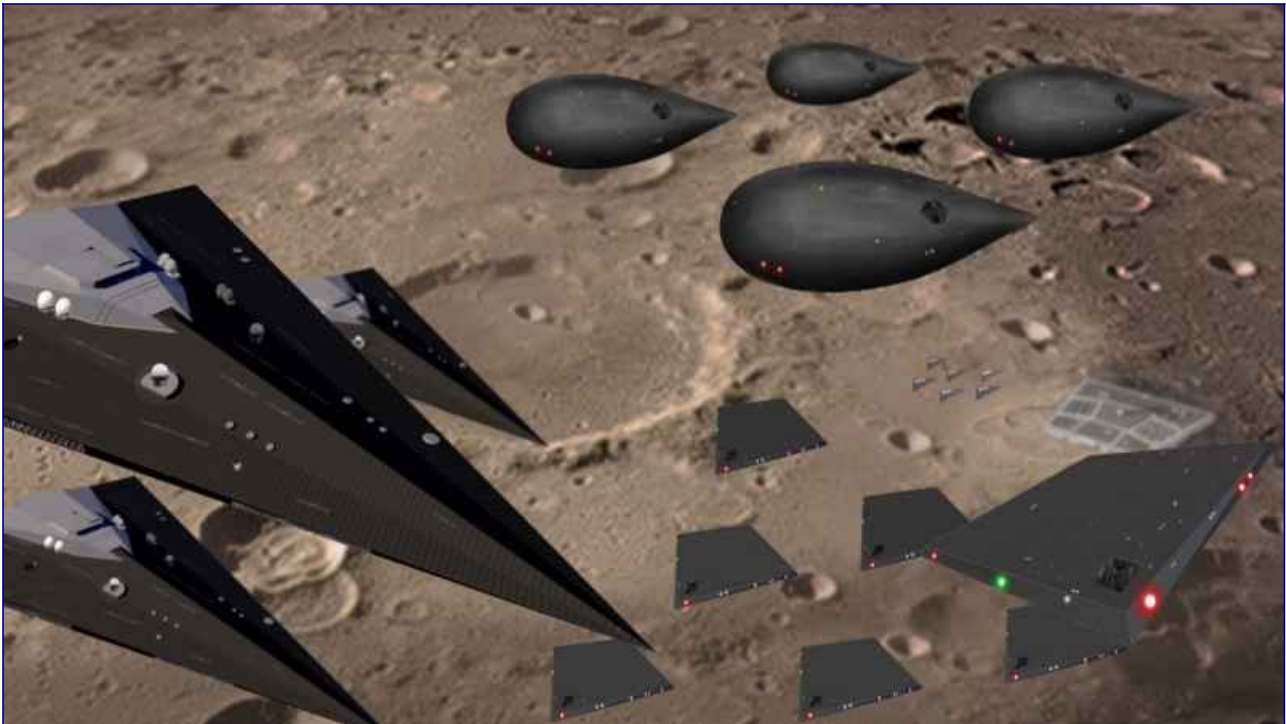

Corey: They had several different types of vessels that you would see that you would associate with them.

David: Well, could you describe some of what made these vessels different? What were their characteristics?

Corey: Yeah. And one of them is a very large wedge-shaped that is very much like Star Wars – the Destroyers, I guess, very much like those, but they're a little bit more sleek.



David: What about the little thing on top? Is that there?

Corey: Similar.

David: Really?

Corey: Similar, but not as high.

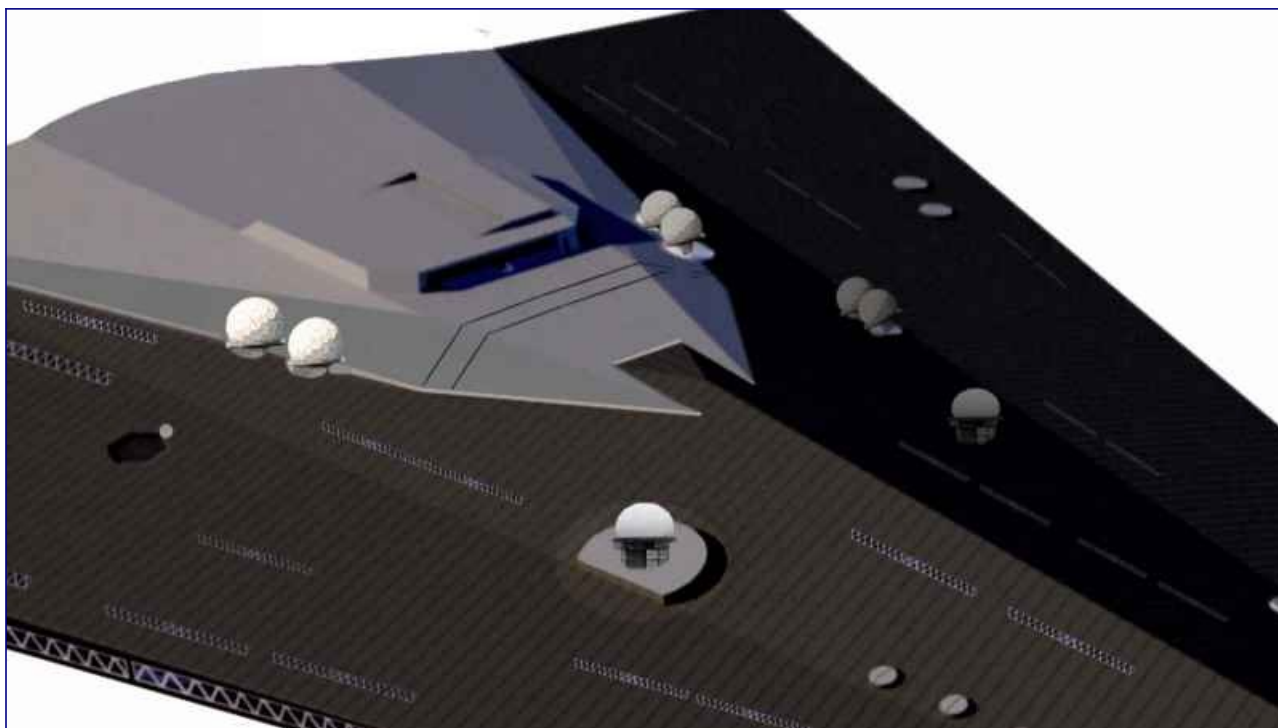

Corey: There's also a very large diamond-shaped vessel that they have.

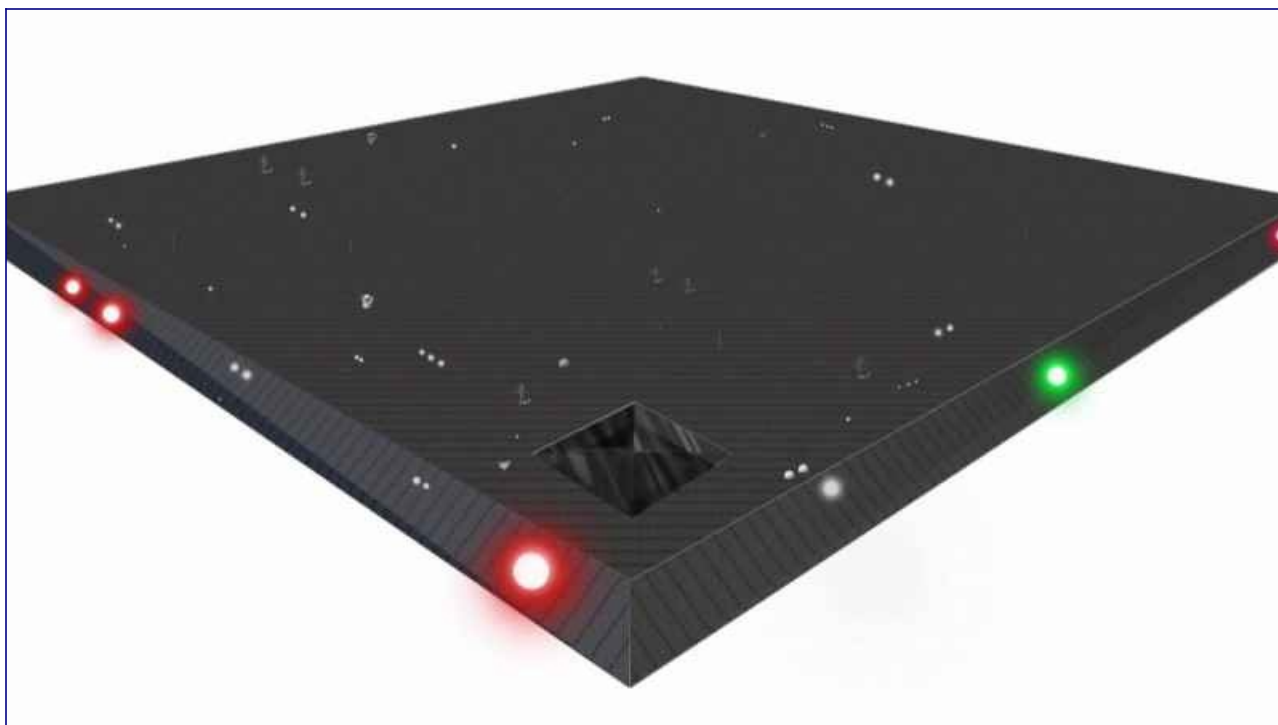

Corey: They have a very large pumpkin seed-shaped vessel.

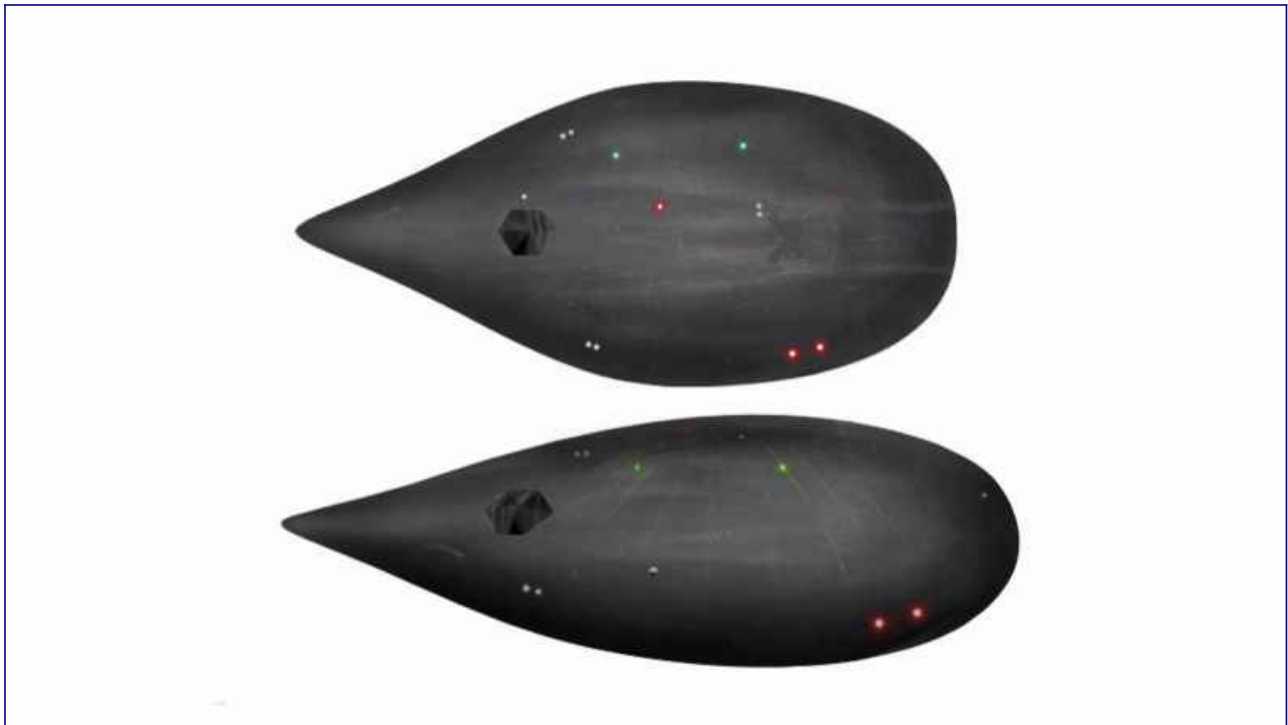

David: When you say 'very large', now, what are we talking?

Corey: Over 600 feet [183 meters] across.

David: Okay.

Corey: But those are smaller than the large wedge-shaped vessels.

David: Right.

Corey: And all we've really known about them is that they fight . . . They're an offensive force. They are for going and doing offensive type of work alongside the Draco. They go outside the solar system on, I guess, conquests or defending Draco territory, helping the Draco on military expeditions.

David: Let's go into the Draco, and then we'll go back to the human support that they get from the Dark Fleet.

Corey: There are a wide range of different types of reptilian beings that are involved with this Draco Alliance, but there are also some insectoid-type beings that are involved in this alliance and some very strange Nordic-type beings. There's been a little bit of information that they are a conquered race that was forced into servitude, but that are also a part of this federation.

David: Well, let's start with some of the basics, which would be if somebody were unfortunate enough to see a Draco, what are they going to see? What are we talking about here?

Corey: There's many different types.

David: Okay.

Corey: Yes, but they're bipedal. They have different types of reptilian beings, some that are quite short in the 4 ½ to 5 feet tall that look very much like Greys. They have reptilians that are of the Draco-type that are . . . they range from 9 to 14 feet plus tall. And there's a whole range of them.

They have different castes within their system. They have like a warrior caste. They have engineers, scientists, almost like a hive. And then they have their royalty up at the top that control and direct everything.

David: So let's start with the top and work our way down then. If you were to see a Draco royal, what are you going to see? What's the height? What are the characteristics? What do the eyes look like? What does the skin look like? Let's just get into that.



Corey: Well, I met, unfortunately, a Draco royal, and it's something that I've refused to repeat and so has Lt. Col. Gonzales. This one was around the 14 foot [4.26M] range, which is incredibly tall. They are incredibly muscular.

David: They couldn't even stand up in a typical room that any of us would have.

Corey: No. Very reptile looking, had vestigial wings and a vestigial short tail.



David: What do you mean by 'vestigial'? What are you saying it is?

Corey: Like the wings at one time would have been able to support them in flight, but now they are just a remnant.

David: So they're just stubby little . . . ?

Corey: Right. They're kind of a remnant of what I was able to see unless they were triple-folded in a way to where they could have opened up wide. I mean, it just looked like vestigial wings.

David: Okay, so we're seeing a reddish or gold colored eye. Is that right?

Corey: When it was interfacing with me, its eyes were morphing the whole time. It was a very psychically powerful being. And it penetrated the frontal lobe. It was almost like there was microwaves

or something shooting into the front of your frontal lobe. It was very invasive. And both Gonzales and I, for several days, at least three days, we had headaches. We were nauseated. As we found out later on, it turns out that a lot of these reptilian higher castes are highly infected with nanites – artificial intelligence-type of nanites.

David: And you said they worship the AI as their god.

Corey: That may not . . . They may be working parallel with, but they have an overlord. I'm not sure exactly what that is.

David: But they're both like afraid of it and in reverence to it somehow.

Corey: Right. So this group is working alongside a human group that has all of this technology that has been enhanced by . . .



*"Approaching The Trapazoid Lunar Building" ~ rendition by Carolyn Hamlett
The above picture is my rendition of what I have seen with physical eyes while aboard a lunar bound craft. The trapezoid shaped building was our destination.*

the ICC has helped them build out a lot of this - these vessels and weaponry. And then the Draco group has helped them enhance it even more so for offensive duties outside of the solar system. And they spend almost all of their time completely outside the solar system. And we knew of . . . There's one of their bases on the moon that is quite a ways from the Lunar Operation Command that is shaped like a pyramid with the top chopped off.

David: Yeah, and you have an illustration of that we can bring up here.

Corey: That's not my illustration. She needs full credit for this image. She had been abducted and taken to this facility. I was very surprised when people wrote me, and someone else had described this same facility on the moon.

David: And it looked exactly like what you saw.

Corey: It looked almost exactly, pretty close, but it's a very good representation. And it's been almost impossible to get good intelligence about what's going on there.

David: Let's go back to the command structure of the Draco, because we gotta map this all out as if people have never heard any of this before. When you see this white being, does it wear any clothes, or is it basically just naked with its scales – white scales?

Corey: Yeah. It was not wearing clothing.

David: Okay. And you have said before it has a very ripped muscular look to it?

Corey: Yeah.

David: Now, my other insider said they weigh 3,000 lbs. [1,360 kg.] and have a 5-foot-wide shoulder span. Would you say that's correct?

Corey: The weight . . . I would say, yes. That's probably close. 5 feet for the shoulder span – I don't know if that's even enough.

David: Really?

Corey: Yeah. Very broad, very intimidating.

David: And they have claws on the ends of their hands and the feet?

Corey: Mm-hmm.

David: What does this vestigial tail look like?

Corey: It was very short. It was about this long [3 feet/1meter] compared to how tall it was.

David: That's not very short.

Corey: Well, compared to how long it is in perspective to how tall . . . but it was wide, and it went into a kind of a stub.

David: Right. Are they all white? Or is this just one type?

Corey: No. There's another type that people describe as red, but it's a real weird brown that makes it look red that also has wings. They're smaller, and they're less muscular, but they're . . .

David: Now, these folks have the vertical slit pupil, right?

Corey: Mm-Hmm.

David: And the eyes are kind of large on the face like a Grey, or is that not so much this type?

Corey: No. It's in proportion to its skull as you would picture a reptile.

David: And there's just two holes for the nostrils or not really a nose?

Corey: Well, it depends on which ones you're talking about. Yeah, they have nostrils that will sink in and go up, and then there are some of them that have sort of a nose that goes up . . .

David: Like a snout.

Corey: Kind of like a little snout.

David: So what is the role of the Dark Fleet with regards to the Draco? What are they doing? Do the Draco run these ships themselves? Are they the pilots?

Corey: No. And I've seen a little bit of misunderstanding about this. The Draco have their own vessels, and the humans pilot control, command control, their own fleet. The Dark Fleet is commanded and controlled by humans.

David: What do the Draco vessels look like if they're not like these Dark Fleet vessels you're describing?

Corey: There's a whole lot of different types of Draco vessels, and a lot of them are shaped like triangles and large deltas. The Dark Fleet is completely human ran. They do answer to and work alongside the Draco Alliance. They're allies, and they go out and they do offensive battles and offensive expeditions together outside the solar system.

David: What are they going for? What is the offense about? What is the goal or the objective?

Corey: We assume that it's conquest or keeping certain areas secure or reined in in their empire, but we really don't know. It's been very difficult to get information and intelligence about the Dark Fleet. And there's been a few defectors from the Dark Fleet that were stuck inside of the outer barrier that was erected. Most of the Dark Fleet was stuck outside. And whatever information has been gleaned from those defectors, I have not heard. So they have been a very large mystery to a lot of people.

David: Why would anybody want to cooperate? Why would any humans from here want to cooperate with these reptilians that are basically like biblical demons or devils?

Corey: Well, one person's demon and devil is another person's god.

David: Sure. So we don't really know exactly what they're doing out there, but you said that when this outer barrier went up, a lot of them got locked out of our solar system.

Corey: Yes.

David: But it appears that a significant portion of their command structure, their elite, were actually in our solar system when the barrier went up?

Corey: Yes. Yeah. Command control and communications were still here, and a lot of their operational forces were outside doing what they do when this outer barrier was raised. So they became stuck outside of this field around our entire solar system that is way, way out past where the heliosphere is - out past the Oort cloud. It's huge. And they can't come back.

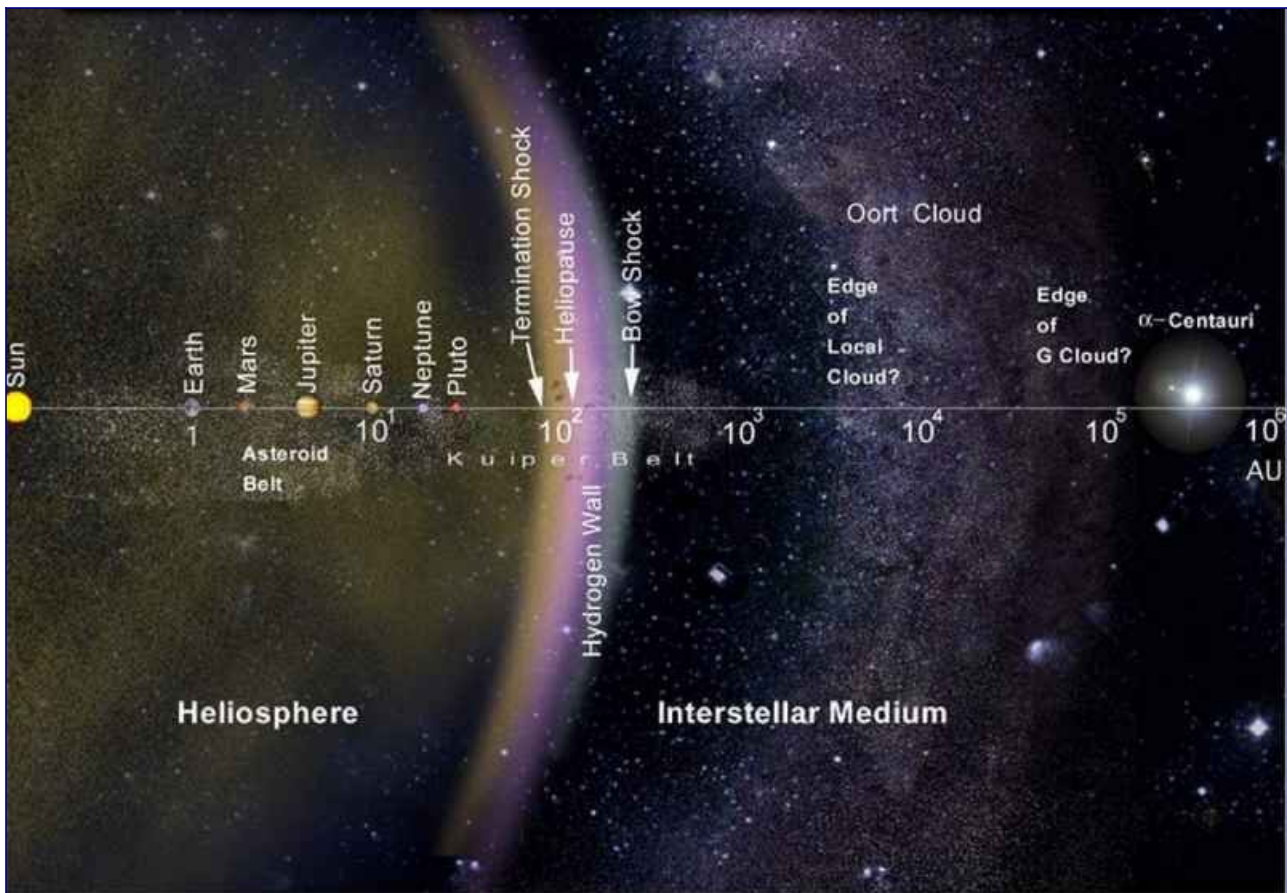

Corey: So the structure that was here has somewhat been cannibalized into the ICC and defected to the Alliance.

David: You mentioned this before, but let's go over it again. If you saw somebody from the Dark Fleet, what are they going to be dressed in? What do they look like?

Corey: They were very distinctive. A lot of the times they usually . . . It's almost out of Star Wars again. They wore . . . They had a very . . . They looked very stern, very arrogant, like they felt very elite. They wore black stormtrooper kind of clothes, just very stern like. Very totalitarian acting. And a lot of the people that ended up going into this program came from a lot of the German secret society Nazi kind of programs.

A lot of them and their ancestors or people that were born later on after these breakaway civilizations occurred have joined the Dark Fleet.

David: One of the things that I heard from the other space program insider, who we could call Jacob, was that . . . and this is going to be hard for people to accept. And I'm interested to see what you're

going to say about this. He said that the Draco had a very vast AI system that was monitoring the consciousness of everyone on Earth. So that if we start thinking in the direction that they don't want us to think, that we'll start feeling tired, exhausted. We'll get distracted. We'll want to do something else.

We might have a panic attack. We might suddenly become sexually aroused and say, "Well, enough of this. I want to go look at hot models on the Internet." And that everybody has what they call a "file", which is the electronic record of all the thoughts and how these various strategies work, and that that was one of the things that they built this vast NSA facility for in Bluffdale, Utah. It is to store the files.

And, apparently, it was not just the files for people on Earth, but there's enough computer power there, he said, the Draco were storing files on several other planets in our vicinity. Does any of that sound like anything you ever heard?

Corey: Partial.

David: Okay.

Corey: Partial. I've been talking openly about the ET, extradimensional/extraterrestrial AI threat since at least June of last year [2015]. And I've been talking about how extensive the threat is and how different ET races and the Secret Space Program are very worried about it.

They're very upset that certain factions of secret Earth government syndicates are very heavily using this AI, this ET/ED AI that is prevalent in multiple galaxies. And they've become what we call AI prophets. They've switched over to where they see this AI as a god.

And this AI helps predict probable futures and has helped them a lot, but it's disturbed a lot of people that people on Earth are using it. And it's been a pretty big revelation to find out that the higher caste reptilians seem to be AI prophets in a way themselves, and when they were able to create a dampening field around one of the bodies after they killed one – because usually when they would kill one, something would happen to where the bodies would disintegrate – they were able to autopsy a body and found it and it was quote "infested with nanites" - artificial intelligence nanites.

David: We covered the AI, those kind of topics. I'm curious if you heard about this Draco mainframe that nudges people into becoming really tired and starting to pass out if they encounter this information . . .

Corey: Well, this Draco mainframe . . . What I'm tying together here is if they're AI prophets, they're working with this ET/extradimensional AI threat, then this could be the same thing. And it is a major threat.

David: Yeah.

Corey: And this could also be a major component with the Dark Fleet, because the Dark Fleet people . . . these guys could be AI prophets if the Draco are AI prophets.

David: I've sat with Jacob and with **Pete** Peterson. I've asked these guys certain questions, and they will literally pass out in the middle of answering the question. They lose consciousness. And what Jacob told me was that this technology is intended to make it very difficult for you to continue thinking when you start getting into the truth and the information.

Corey: This also has to do if you have an AI signal infection. There are different types of things that will keep you . . . like, I had certain knowledge that they were unable to blank slate me with, but through different entity attachments or if they have AI attachments, they can manage people to where if they try to talk about something, they have anxiety attacks, or they get really sleepy – that kind of thing. So they have ways of managing people that they can't totally shut up or blank slate their memories.

David: So do these Dark Fleet personnel actually . . . Do they have homes here on Earth? Do they go out to work? Do they drive into a local military base and portal out?

Corey: I would assume that they are 100% vested off world.

David: The way you're describing, it sounds very military. I'm wondering is it all men, or are there women in the Dark Fleet, too?

Corey: I'm sure there are women, but I personally only saw men.

David: Hmm.

Corey: Yes, they're very regimental, very totalitarian, very . . . the energy you feel from them is very unnerving. They don't feel like pleasant people at all.

David: Are there different races of normal humans that we'd see on Earth in the Dark Fleet?

Corey: Yeah. It's not a Caucasian purity kind of . . .

David: Really. Okay. You mentioned that the Draco have different reptilian types, and you said there's insectoids as well. Did they co-mingle with these humans in the Dark Fleet, or is the Dark Fleet simply a human fleet that is a support crew for the Draco Alliance?

Corey: They are . . . It's a human, completely human, fleet that flies in support of and alongside the Draco fleet.

David: So you don't . . . You're not going to see extraterrestrials on these ships.

Corey: I don't think so. I've heard people talk about advisers, maybe one or . . . some advisers being on board, but this is like second, third-hand information that I've heard people talking about. There's a lot of mystery about . . . that has been so compartmentalized about the Dark Fleet. That is one of the biggest secrets still remaining even with those in the SSP Alliance unless there's information they haven't shared with me recently that they have found out.

The Dark Fleet had a lot of secrets.

David: Would it be possible for somebody to get brought into the space program and be kept compartmentalized enough that they wouldn't even know about the factions or they'd never have heard about the Dark Fleet at all?

Corey: Oh, yeah. If they were not in a position to where they had a need to know, they had no need to know. And whatever position you're put in, you're told basically you're at the top of the totem pole. Your ego is boosted up. You're told you're special. You're told you have open access to all the information that is. That works from the military projects that are pretty far down on the totem pole to all the way . . . levels above the totem pole that I don't even know exist – above what I knew.

There's people up there that think they know. They've been given the full clearance, and they don't have

it all. So that's the way it's all designed so that the lie or the story can be different on every level and in every compartment of every level.

David: What kind of technology are we seeing in the Dark Fleet? Is it the same as what you'd see in other factions of the Space Program?

Corey: The offensive technology is very similar to the ICC with caveats and enhancements given to them from the Draco, I'm told. I don't know exactly what all that would be.

David: Do they have a kind of situation like what one of the insiders told me, which is the more technology you have, the less technology you need? Or you'll have, like, one device that just does so many different things that you don't need a bunch of different devices anymore?

Corey: Right. Like the same type of technology that would create a torsion field that would cause your vessel to move through time and space could also cause a local torsion field where a craft is and contort the space around a ship and cause a ship to break up. And that's beyond using particle beams and all of these things that a lot of people are talking about – different types of energetic weapons. They've got types of weapons that are way beyond what a lot of people are describing.

David: Do we know anything about how the Dark Fleet are recruiting these humans? Are these humans that grew up in space? Are they people that served in the military here on Earth? Are they from the so-called Illuminati? Where are they coming from?

Corey: They were being drafted from some of the MILAB programs, but most of them are bred for what they do. They come from a lot of these, I guess, Illuminati or secret Earth government syndicates and off-planet colonies. And they're very much vested off planet.

David: So you could be born on Earth in a so-called Illuminati family and get pulled into this if that was your desire, potentially?

Corey: Not necessarily desire. It has to do with . . . They find out what your talents are, what your proclivities are, what you're best in, and then they groom you to later on draft you into what they think you're going to serve them best as.

David: So if you're high on the scale of being a sociopath and having no conscience, no concern about torture and death of another person, then you're going to get fast tracked into this Dark Fleet? Is that kind of the idea?

Corey: That's a possibility.

David: That's the 'talent' that they're looking for?

Corey: Possibly. Like I said, we really don't know. There's a lot we don't know about the Dark Fleet. They're somewhat of an enigma. I think the Secret Space Program Alliance has received a lot more information very recently about them. I have not been briefed on anything other than what we knew before.

David: Do we know how many bases the Dark Fleet has? Do they pretty much stay in their own bases? They don't even intermingle with the other bases?

Corey: At times, they've mingled at the LOC, but, yeah, they have their own bases – extremely restricted – and, yeah, they have quite a few. There's a lot going on in the Oort Cloud with a lot of different groups, including the Alliance. The Oort Cloud has quite a few large bodies in it that have bases in it.

David: Like moon-sized spheres?

Corey: Very large moon-sized spheres. There's quite a few.

David: So then they'll dig inside like we've talked about before and build bases in there?

Corey: Right. There's quite a few objects out there that really haven't been discovered or talked about in mainstream that . . . There's a lot of activity going on in the Oort Cloud.

David: Would you say that the Dark Fleet would sort of be like the military wing of the Draco operation? They're not involved necessarily in this trade that the ICC is doing of manufacturing products and having people come to the showroom?

Corey: No. They are the business end, the tip of the spear, offensive, pretty much like sending in the SEAL team to go kick butt, take names. They're purely offensive. When they're leaving, they're leaving to do battle or some sort of tactical action.

David: These guys clearly seem to be the most negative of all the factions.

Corey: Yeah. You can feel it.

David: So what is being done that will enable this to all lead to healing for our planet? What is being done to stop the Draco?

Corey: Eventually, what's going to occur is basically going to be us saving ourselves. The Sphere Alliance is not here to save us. They're basically equalizing the playing field a little bit in some ways, but they have made it very clear that we've got to come up with our own solutions to these problems.

We've got to step up to the plate, do our own inner work and fix these problems. And a lot of this isn't going to happen until after there is some sort of catalyzing event where everyone on the Earth, to where everyone on the Earth, figures out that basically they're slaves, free range slaves, and that there's a lot going on that they didn't know about.

And then these data dumps that I've been talking about will occur that have just so many terabytes of information it will take people forever to go through, that's going to talk about all the crimes against humanity, all the different stuff going on with different ET groups, different secret Earth government syndicates, and different Secret Space Program groups.

David: All right. I'm [David Wilcock](#). This is [Cosmic Disclosure](#). And as always, we thank you for watching.

[Cosmic Disclosure: Viewer Questions Part 3](#)

Season 4, Episode 7

David Wilcock: All right. Welcome to “[Cosmic Disclosure](#)”. I'm your host, [David Wilcock](#), and in this episode, we're taking your questions, so that I will become the embodiment of you asking your questions to **Corey** so we can hopefully get some different perspectives on this besides what I might come up with on my own.

So **Corey**, welcome to the show.

Corey Goode: Thank you.

David: All right, let's get right started on this. I noticed a couple people asked in reference to the binary star system possibility, including the presence of a large planet. I know it's been talked about since the '80s. Do you or the Inner Earth people have any info regarding Planet X, etc., and a possible timeline?

Corey: My timeline of a Planet X. There is information about large bodies within the Kuiper Belt on the ecliptic plane and outside the ecliptic plane.

David: When you say large, how large are we talking?

Corey: Larger than Earth.

David: Really?

Corey: Yes. And because of gravitational forces, they've become spheres. And there's been information presented about them entering in the same way long period comets do into our solar system. But I was given no information, saw any information, about there being a Planet X as I have seen presented on the Internet.

David: Well, this is, of course . . . The root of the question would be the classic Zecharia Sitchin model, which is that he interprets the Sumerian cuneiform tablets as saying that there is a Nibiru, which is a planet that he believes has the 3,600 year orbit. It's very elliptical. And his hypothesis was that when it swoops into our solar system that it's causing catastrophic events on Earth.

Corey: And they did mention the binary star hypothesis, which some call the nemesis star, which is they say that we're a failed binary star system and that there is a brown dwarf further out towards the heliopause.

David: And you say, "They say . . ." They who?

Corey: They being those in the upper Secret Space Program and the information that was on the smart-glass pads. And that's really all the information I have on anything Planet X related.

David: So are you refuting Zecharia Sitchin's model of a 3,600 year orbit for Nibiru?

Corey: In the recent Inner Earth meeting I had, I was provided information that was stating that the Zecharia Sitchin narrative was not accurate, that it was a narrative put forth by some of these syndicate groups.

David: What you said, though, is very open-ended.

Corey: Yes, but . . .

David: There are obviously Annunaki. You've seen the Draco.

Corey: Right. Right.

David: So there's got to be some truth to it.

Corey: Right. Yeah, there's always truth. Like I said, the Ancient Alien Hypothesis is true, and there's nuggets of information in there that are a part of a certain secret Earth syndicate's belief system that they've brought in to make a part of our belief system.

David: Sure.

Corey: And this is according to the Inner Earth civilization. And I did follow up studies of my own trying to break through the Zecharia Sitchin information. And I'm not a scholar on linguistics, ancient Sumerian or anything like that. I couldn't find anything in all of the translations that scholars use that was in his books.

David: So are you saying that the translations of Zecharia Sitchin claims to have made from certain scriptures do not actually appear to be accurate of what they really say?

Corey: That appears to be the case.

David: And how extensive is that?

Corey: Very extensive.

David: Really?

Corey: Yes.

David: So there is a kind of a confabulated psyop disinformation campaign going on with this.

Corey: Yes.

David: Okay. The second question deals with this subject as well, so I think it's good to just dive right into that. "Mainstream science is finally working toward admitting that there's a ninth planet in our

solar system with a huge mass and a giant elliptical orbit.” Obviously, we just talked about that.

My question for **Corey** is this: “Is that planet inside the barrier that the Sphere Beings have put up around our solar system. And if not, what will have to happen for this planet to cross into our solar system?”

Corey: This barrier is where the heliopause is, where the electromagnetic influence of the sun ends. That's past the Oort Cloud – past the Kuiper Belt, the Oort Cloud. The heliopause is the end of what they consider where the sun's influence leaves off and other stars begin or open space is.

David: If you were going to look at the distance between the sun and Pluto as if it was, let's say, something you can put in between your fingers. How much farther than that is the boundary of the heliopause?

Corey: Probably several parking lots away.

David: Wow! So it's much, much, much larger than where the planets are.

Corey: Absolutely.

David: The other part of the question was admitting there is a ninth planet. Now, based on what you said before, it doesn't sound like it's just one planet, right? Is there more than one body out there that's large?

Corey: Yes, there are. And what was recently explained to me was that this super planet that many call - I mean, it's called a lot of things, Maldek, Electra, Tiamat, but . . .

David: The destroyed Super Earth you're talking about.

Corey: Yes. That in the asteroid belt, there is just a very small fraction of a percentage of what was actually there at one time. It was such an energetic explosion that much of the Kuiper Belt is actually what made up that planet – it's oceans, layers of its rocky core.

David: So just for viewers who don't track this, tell us the relationship between the asteroid belt, the Kuiper Belt and the Oort Cloud.

Corey: Okay. As you move out from the rocky planets to the gas planets, the first belt you run into is the asteroid belt.

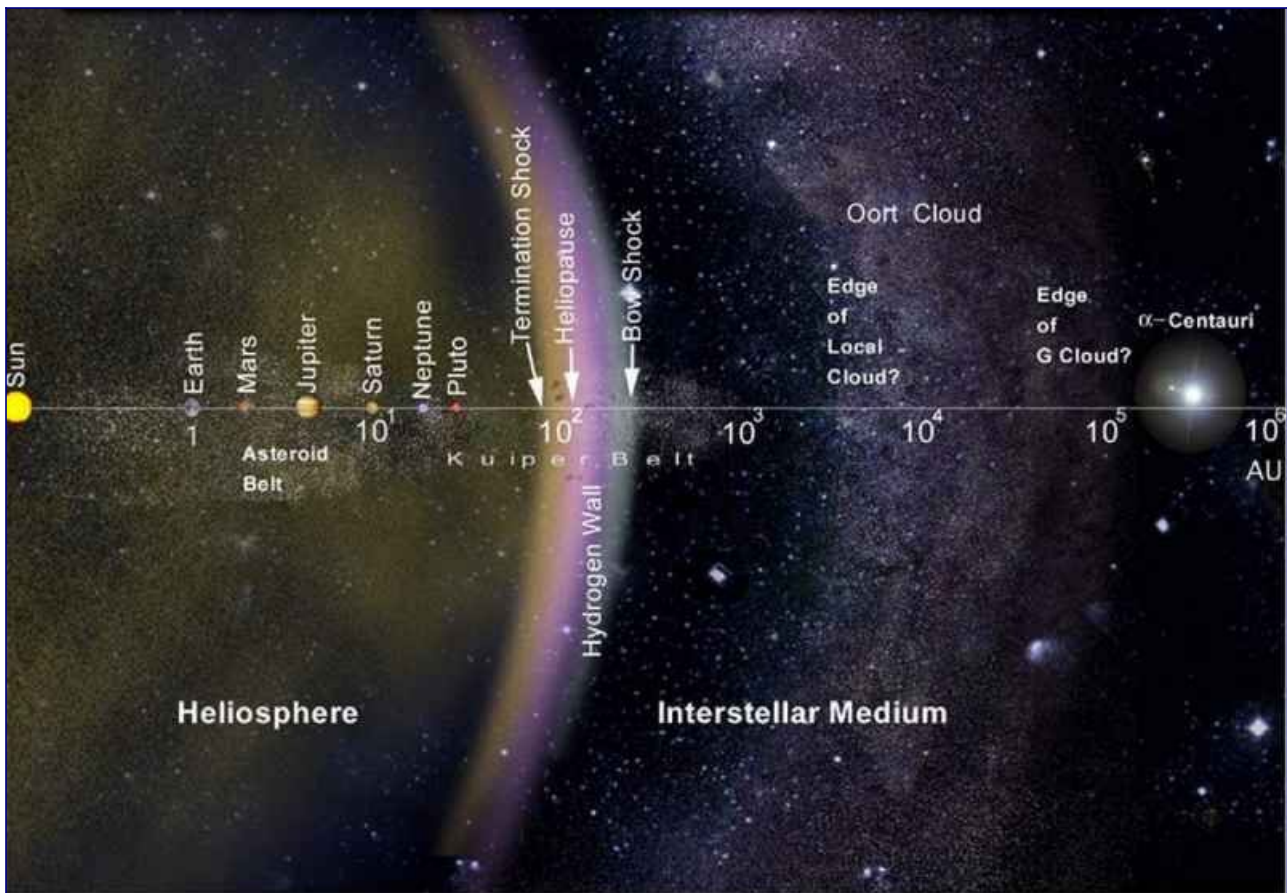

And then you run into the gas giants. And then you reach the Kuiper Belt. And then further out, you reach the Oort Cloud. And the furthest place that you reach that is considered the solar system is the heliopause.

David: Right. So do you think that these planets . . . You say that there's more than one planet out past the Kuiper Belt?

Corey: Yes, and a lot of these are made up of just ice. And they're bigger than the Earth, but they're ice planets.

David: Do they have Ancient Builder race settlements on them? Or were they the fragments from this exploded planet and they're new?

Corey: They were fragments from this exploded planet.

David: Okay.

Corey: And they're in the ecliptic plane, and as I said before, outside of the ecliptic plane as behaving like a long period.

David: I think some of the viewers might be a little frustrated though, because on the one hand you're admitting that there might be something like what the Sumerians called Nibiru out there, but you're not saying anything about whether anybody lives on it. Does it have any recent bases on it or anything like that?

Corey: Atmosphere? Like I said, I have not been presented any information or seen any evidence of there being another planet that's coming in every 3,600 years that has living beings on it that matches that narrative.

David: Okay. And you say some of these objects are larger than the Earth?

Corey: Yes.

David: Do you know approximately how many of them there are that are large?

Corey: No, but I was told that at one time there were three that were long-period comets that would come in and wreak havoc. It seems that . . . I was told that one of them eventually did have a collision with the sun or went into the sun a long time ago.

David: Do you think creating some kind of a UFO religion that's actually fraudulent helps to confuse the possibility of Disclosure when it eventually comes out? Because you're really probably going to be upsetting a lot of people with your answers to these questions.

Corey: I've become used to that.

David: Yeah.

Corey: But, yeah. This is going to upset a lot of people or challenge their paradigms, but all of us . . . I've had my paradigm changed many times. And we've got to be willing to grow and keep an open mind, but use discernment. And I'm reporting from my experiences – my involvement. There's obviously information . . . I could not have access to all the information available. So there's plenty of information that I didn't access during my time. So there could have been that information like you're talking about that I did not access. I just never accessed that information.

David: If you had to guesstimate the total number of hours you spent poking around the smart-glass pad, how many hours you think that it would be?

Corey: It's impossible to estimate. There were times to where I would sit there, and that's almost all I would do in a day.

David: So for the whole waking hours of the day, like 16 hours.

Corey: Right, on the research vessel especially.

David: How much of it was text, and how much of it was video?

Corey: It was presented quite a bit of text. There would be video and still photography. And there were areas kind of like at the end of papers, footnotes, different point of views from different scientific groups sponsored by different syndicate point of views – people that had different . . . Just like here in the regular community, we see everybody has all these different belief systems. It's no different in these syndicates or in the space programs. People have belief systems.

David: How were the different groups identified? Did they have names or were they coded?

Corey: No, they were just listed as different theses or different points of views.

David: Right.

Corey: But it was obvious which way they were leaning by the information they would bring in. And I didn't spend a whole lot of time in the footnotes reading because those were the things that were very thick in scientific information, and that was not my forte.

David: Okay. So we got another question for you now. “Why is it that the Sphere Alliance does not give a more direct sign to humanity about their existence? If it is in their interest for humankind to start shifting towards a higher consciousness, why are they holding back so much? Some people need a more powerful push in the right direction than others, but that doesn't mean that they don't have that spiritual quality to them. Is this some kind of a test?”

Corey: Absolutely. Already they're backing off from me wanting to report anything about them at all because so many people instead of focusing on their selves are focusing outwardly and trying to reach out to them with their minds. Some people are even praying to them. This is the genetic programming that they want us to break. They want us to get off our knees, quit looking to saviors and look inwardly

– fix what needs to be fixed and get on with it. They're not here to do it for us. They're not here to say “Peek a boo! Here I am. Now you know I'm here.” There is a Santa Claus, so decorate your tree.

They've made it very clear that we have just as much a role to play in our future timeline and how things unfold as any of the other beings that have been involved in this grand experiment.

David: Maybe people are having trouble understanding how you would be the only person publicly right now who seems to have been contacted by these beings directly. Why wouldn't they have cast a wider net at this point?

Corey: They have. There's people that just have not come forward. There are some people that have contacted us here and there, but these people are not being led to come forward. A lot of people that have given reports are people that have been taken up to the Lunar Operation Command in their pajamas, walking around. There's more going on. People maybe having more experiences than they realize. They could be having them . . .

When the Blue Avians approached me, they did it in a quasi-dream state first so not to freak me out too much. And usually that's one of the ways they first start approaching people. When they start showing an energetic or a sign that they're ready, they'll start approaching them in dreams. And then as they show that they're mature and ready, more can occur.

David: What about the phenomenon of orbs?

Corey: What I was about to say with myself, that one of the reasons I think that I've had the contact was because I am authorized to have the contact, because I had had contact with other beings as a part of the program when I was being raised to interface with these beings.

David: Right.

Corey: So for them to pop into someone's house right now while they're watching this show and say, “Yes, I'm real. Now get off your rear and change the world.” The people are not doing it for the right reasons. We've got to motivate ourselves and solve all of our own issues and not wait for all these different savior beings to come and do it, or savior groups, and overcome this genetic programming we have to look for a leader or a savior.

David: You had mentioned before about orbs that there are ways in which people are being contacted.

Corey: Yes. People are seeing the orbs. That's the largest way people are being contacted.

David: So what might happen to someone?

Corey: They will be in a room and they will see an orb zig-zag around and either disappear, or they will see it zig-zag around and stop and disappear. And they'll think, "Wow! That was a very interesting experience." Or some people have had conscious communications with these spheres.

A lot of people don't realize that when they see these spheres, sometimes they're having a communication. They're with their higher self, and they're not consciously perceiving the communication with the orb that they see.

David: So if the Cabal is following these rules where they can't be completely hidden, and they have to tell us what they're doing, then why do these positive beings follow rules where they are hiding?

Corey: Well, it's not so much that the Cabal has rules where they have to show us what they're doing. That is how they manipulate our mass consciousness, and our mass consciousness is their power and their magic. They're showing us what they're doing so we manifest what they want us to manifest.

David: Okay. It just seems that whatever negative energy these things that they're doing generate, that it doesn't generate the energy they need if they don't tell us what they're doing in some way. That's the Loosh principle, right?

Corey: To put it in perspective, these sphere beings are not contacting other ET beings that are in our solar system or ancient breakaway civilizations below the Earth either that are much more advanced than us. They're not answering their hails. They're not talking to them. They're ignoring them. So if you're out there and you're being ignored, join the club. There's many dozens of beings that are wanting to be incommunicado with them.

David: Okay, so the next question here is related. "Other than helping others to raise their consciousness, what else can we do to help bring about the process of Full Disclosure and to help usher in this change to society?" So they're saying other than helping others raise their consciousness – because that's been the main message – what else can we do to bring in Full Disclosure?

Corey: That's a very interesting question, very interesting time. Right now is . . . I mean, if you do not see the trickle of disclosure around you, you're in deep denial. There is a narrative that is being put

forth of disclosure that we're going to have to live with if we're not willing to get out and make it known that we want Full Disclosure.

How we do that - we're going to have to come together. We're going to have to get over all of these distortions, personal truths or just basically agree to disagree on all of our belief systems and do what the Cabal has done.

They have all different belief systems, but they found a common goal, and a very small number – less than 1% of the population – is doing what to 99% of the population?

Imagine what we could do as a community if we could get UNITY in the community and agree to disagree on certain things and focus on our common goals and our common enemy. Doing that . . . The mass meditations are great, but raising your own consciousness and raising the consciousness of others through the way you behave every day – that's the way to do it long term. But coming up in the short term, we're all going to have to put some skin in the game.

David: So we're talking about Full Disclosure, and it seems as if – to get back to the core of this question – that the individual watching this show right now is relatively powerless. You're saying these are geopolitical forces way beyond our control. They have EMPs. They could knock out power grids. They have Internet kill switch. Is there something that the audience could do, since I would imagine most of these people believe you, or they wouldn't continue to watch? They're not sitting here and laughing at you and getting off on being skeptics. They believe you. That's a powerful coalition. Is there something that could be done to help that Full Disclosure take place?

Corey: Yes. We talked earlier about the Cabal doing things out in the open to manipulate our mass consciousness. One of the major things they've done is strip any understanding or knowledge that we have of the power of our co-creative consciousness. That's the only way they rule us. We can use that co-creative consciousness to manifest this timeline to where we get this Full Disclosure.

David: That sounds like gobbledygook.

Corey: It does, but you've put forth in your shows and talks . . . How many times have you talked about mass meditations having a direct effect? You and I both have talked about scientists have proven that observing an experiment has an effect on its outcome. Consciousness has an effect on reality. And

whether you believe it not, it occurs.

And what was communicated to me is that all of these – the Sphere Being Alliance, the Inner Earth and even the Secret Space Program Alliance – they have been sitting back wondering why, with all this information we're receiving, we're still sitting back waiting for saviors and not taking to the streets?

And that's the initiative that people are going to start hearing us talk about – unity in our community, having people put aside their differences and focus on Full Disclosure, not only in the meditative way, but getting people presented to the mainstream type of people that are credentialed, that have information that isn't going to throw a wrench in their paradigm too much – just to get them thinking.

And then they'll branch out and start seeing more of our information and broaden their consciousness to get the consciousness of the sleeping masses on our side. And our consciousness is like a rudder for the boat. We can help guide which way we go. And this was made very clear by all three sources.

David: Okay, so let's have another question. “Many of us would like to be in first contact with both Inner Earth people and positive ETs as soon as possible so we can help the Earth and learn from them. We have been waiting a very long time for this to happen. Is there any way to speed up this process of first contact for those on the surface in small groups who are already prepared for it?”

Corey: I would say stop focusing on them and start focusing on yourself. When you are ready, it will be more likely to happen. But reaching out with your mind, going and looking for them when you're not ready can . . . A lot of times you think you're ready, but you're not. And you have to be careful when you're looking to make first contact, because like I said, be careful what you wish for, because everyone wants to have an amazing experience. They want to have an out-of-this-world experience, but it can quickly blow up into something that . . . and you can become a part of something a lot bigger than you really want to.

You can all of a sudden be an introverted person that doesn't like to be in front of people that ends up being in front of a camera every week. Ha, ha. You may be pulled out of your comfort zone and put in . . . You just don't know what's going to happen.

David: Let me ask you this. People seem to think that if they get this contact that it's just like a wonderful cosmic high. Do the rules of the universe allow the negative to counterpunch if somebody

did receive a contact like this? And if so, what might the counterpunch start to be? What could happen to someone if they actually achieved this contact?

Corey: You could start receiving visits from the military – black ops groups, Special Access Programs groups. You can start getting attention from other groups. So when you get attention from one group . . . You never get the attention of just one group.

David: Do the Cabal groups have the technology to know if someone has had a contact?

Corey: Yeah.

David: Is there ways they can detect it?

Corey: Oh, yeah.

David: There are?

Corey: Yeah.

David: So the people asking this question might think that they're in sort of a little Petri dish that's sterilized from its environment, and it's hermetically sealed, when in fact they're becoming part of a community when this happens – a community that's very aware of it.

Corey: Yes.

David: Is it possible that someone who received a contact like this could start to receive negative telepathic downloads that they think are positive?

Corey: Well, yeah. One of the things that the military Special Access Programs do is they'll come in with this Voice of God technology and then start harassing people and confusing them – giving them conflicting information from the other information they received. They'll do a psyop on them and make the person think they're crazy, or make their family think they're crazy and have them committed . . . the dirty tricks. There's volumes of books of their dirty tricks.

David: Okay, so we have one more question here in the short time we have remaining in this episode, which is different than the others. And it regards these people from the Inner Earth. “Are these Inner Earth people fourth-density people, or are they people who are from third density like us but are far more advanced?”

Corey: They are fourth density. That is what was directly communicated to me about the ones I visited in this Inner Earth council meeting, and also the Mayan breakaway civilization. I was told way before I knew about this group that I met recently . . . I knew about the Mayan breakaway group, and I had interacted with them briefly. And I had known that they were fourth density. And then I found these people also are fourth density.

David: I want to generalize a little more for the sake of focusing on this question and the broader implications of it. If what you're telling us is true, there appear to be many, many beings out there that are solid looking.

Corey: This has to do with frequency. The density has to do with the frequency that everything about them oscillates at.

David: When you reached out and touched Kaari's hands like this, you're touching hands, right?

Corey: Right.

David: You're not just waving through a cloud.

Corey: No.

David: So this fourth density . . . They're solid in some way.

Corey: Right. And ourselves . . . From what I'm told, since at least the '20s, '30s, we're third-fourth density transitional.

David: Really?

Corey: So we're in a transitional state ourselves.

David: Extraterrestrials, as a general rule, are leaving behind bodies in crashes, Roswell only being the most popular example. Could a fourth-density being leave a dead corpse behind?

Corey: Yes.

David: It can?

Corey: Yeah.

David: So they are flesh and blood?

Corey: Yeah. Yes.

David: Are there beings that are third density that are appearing to us as extraterrestrials, or are most of the extraterrestrials at least fourth density – as far as what the Cabal and these groups are seeing?

Corey: Most of them are fourth density. They are like the merchant race – very, very, very third-density type of beings.

David: This is the type you said kind of look like a horse – they have a horse-like or donkey-like face?

Corey: Like a dog. More like a . . .

David: A dog.

Corey: Yeah. Dog-ish, canine-ish look.

David: Right. So those are third density but very old or something?

Corey: A lot of these groups are . . . You have third density, you have fourth density, and you have fifth density groups. In the Super Federation, some of these groups . . . and a lot of these in the Super Federation refer to themselves as Guardians and are higher density – fourth and fifth density.

So we have a lot of preconceived ideas about what dimensions are, what densities are, in between densities what happens. Do things just phase out?

We going to have in the near future a lot of information that's going to change our point of views on a lot of these terms.

David: So just to summarize what you're saying, our traditional – let's say Judeo-Christian - viewpoint that you become this energy ball when you ascend to the next level of human evolution is a misconception compared to what we now know from boots on the ground observational data like what you're providing us with.

Corey: Right. It's more of a consciousness shift, and as the consciousness shift occurs, the vibratory consciousness shift occurs within an environment that has a higher vibrational energy shift as well.

Your consciousness . . . You have more access to using that consciousness to manifest things in your reality.

David: So you could be a being of flesh and blood, but you might be able to walk on water, levitate, manifest objects – these kinds of things.

Corey: Do things that would be miraculous to us, yes.

David: That's really cool. That's all the time we have for this episode. I'm your host, [David Wilcock](#). We got the one and only **Corey Goode** here. Totally exciting to talk to him about this stuff. I hope you're enjoying it. We'll see you next time.

Cosmic Disclosure: Inner Earth Update

Season 4, Episode 8

[David Wilcock](#): Welcome to “[Cosmic Disclosure](#)”. I'm your host, [David Wilcock](#), and I'm here with **Corey Goode**. We're talking about the Inner Earth, a fascinating sequence of data that we have been covering on this show. So **Corey**, welcome back to the program.

Corey Goode: Thank you.

David: All right. So in the previous episodes, what we've gone through is the updates about the first meeting that you had with the people in the Inner Earth.

Corey: Correct.

David: But you have since been taken up there or taken down there again.

Corey: Correct, but before that happened, there was a meeting at a Secret Space Program base in the Kuiper Belt that I was brought to by the Secret Space Program Alliance.

David: When you say before that happened, you mean before you were brought into the underground . . .

Corey: Before I was brought back to . . .

David: The underground cities again?

Corey: Yes. Before that occurred. And this was a pretty significant meeting. The Inner Earth group that . . . The group I had talked to that I can now say they are named the Anshar, the group that had the Saturn amulet.



David: Ah.

Corey: The priestess, her name was Kaaree. And she was going to be present with a delegation of her group, so I was invited and was very excited as well.

▪

Corey: And her delegation arrived on one of their vessels, I believe, because I didn't actually see them arrive. I just saw them coming in to the main area where we were to meet them, to then escort them through some passageways into an area for the meeting.

And Gonzales and I were . . . I mean, you could just feel the excitement. They were just beaming with excitement and anticipation.

David: So they hadn't been in contact with the Sphere Beings before?

Corey: Yeah, yeah. Per the discussion we had in the library, they hadn't had any contact, and this was their first contact with the Sphere Beings, which they referred to as the Guardians. So they were very excited, and when we got them in the room . . .

David: What did this base look like, though? Because you're seeing it, but the audience is not necessarily seeing it.

Corey: Yes.

David: How cool does this place look?

Corey: It's not a real cool, super high tech sophisticated place. It's more of . . . It's pretty spartan.

David: Okay.

Corey: You wouldn't . . . It's not like . . .

David: It could be a building on Earth?

Corey: If you were underground, maybe.

David: Okay.

Corey: Like an underground military base.

David: Okay.

Corey: Nothing super significant that you'd think would be sci-fi looking on the inside.

David: High ceilings?

Corey: About normal.

David: Okay.

Corey: Yeah. About . . . Except for the area that we went into that was a meeting area, a presentation hall. It looked like they stored stuff in their – back in one area. I wasn't really paying attention to what exactly it was, because I was anticipating the arrival of a Blue Avian.

David: Was it dark, or was it brightly lit like a typical hallway with lights?

Corey: It was well lit.

David: Okay.

Corey: Yeah. The Anshar delegation comes in.

David: To this meeting room?

Corey: Before we got into the meeting room, I greet Kaaree, and she's more in a business mode, or she's anticipating this meeting, but she's nice and greeting me.



Corey: But, you know, we immediately walk the path back to where we're going to have the meeting. And Gonzales knew where we were going. I didn't. So we get back, and we walk. It looks like we're walking . . . like this wall behind us. We walked as if the delegation is going to be facing this wall behind us. And Gonzales would be kind of like if you were standing right there in front of me, and I was standing about 12 feet away, maybe 15 feet away, facing him. And Kaaree and two others were up in the front, and there were several more with her in the delegation, but they were up to the front, and we were sitting there waiting for Raw-Tear-Eir to appear, and to our shock, a Triangle-Headed Being appeared.

David: This is the one that didn't even talk . . .

Corey: Right.

David: . . . when you met with him.

Corey: Right.

David: Yeah.

Corey: Yeah, it was completely silent.

David: He seemed like the most advanced out of all of them, right?

Corey: Maybe. I don't know, but it never communicated with me the first time or this time.

David: Right.

Corey: So it was the most bizarre thing. I'm sitting there looking across . . . We're watching back and forth. It's completely silent.

▫

Corey: The Triangle-Head Being, as I described before, was 10-feet, 11-feet tall.

David: Gosh.

Corey: And its head was as wide as its shoulders, if not just a little bit wider.

▫

It was very thin.

▫

Corey: Its arms and legs – very thin. And it seemed almost as if it was in . . . not really water, but it was just slowly, just waving its . . . I mean, it just barely . . . It was very strange. Its legs and its arms . . . And as last time . . . It has three fingers and three toes. And it was up on its toes like tripods, and they were doing like this.

And they had a completely silent exchange that went on for some time. It's really almost impossible to judge time accurately. It went on for some time. And they were just sitting there looking at each other, and you would . . . and the only movement was the slight movement of the Triangle-Head Being.

And Gonzales and I keep looking at each other and looking back and forth, and you would see some slight mannerisms here and there. And then it was over. The Triangle-Head Being . . .

David: How long did this silence last?

Corey: It may have been . . . anywhere from 30 to 40 minutes subjectively. I mean, it went on for awhile.

David: Subjectively.

Corey: . . . anywhere from 30 to 40 minutes subjectively.

David: Wow!

Corey: I mean, it went on for awhile.

David: And you didn't get any intuitive hits on what they were talking about?

Corey: The only intuitive hits I was getting . . . I wasn't feeling anything from the Triangle-Head Being, but I was feeling . . . I felt some anxiety come up. I felt excitement. I felt a little bit of confusion and different things, but I did not know what those emotions were associated with content-wise in the conversation, because we were not privy to the interface that was going on between the two.

After this had ended, and the Triangle-Head Being . . . just . . . It's like you change the radio channel. And it's gone.

David: It just winked out?

Corey: Mm-hm.

David: Was it a fade, or was it just a sudden disappearance?

Corey: Winked out. Gone.

David: Uh.

Corey: The delegation was excited, but at the same time, there was some trepidation and a little bit of . . . They were upset a little bit. And no time for small talk. They had a meeting with that same Inner Earth Council that I had originally met with for the first time with Gonzales that we spoke of in previous episodes. They had to rush back and meet with that group.

And as they were walking back . . .

David: Was it only the Anshar that actually were granted the meeting with the Triangle-Head Being?

Corey: The Anshar were there, and there was one other group there.

▫

David: Which amulet did they wear?

Corey: The star.

David: Okay.

Corey: But they were very far in the back. They were moving quickly to get back, and as I was leaving, I was asking how it went and trying to make small talk. And Kaaree said that it went well, but they learned quite a bit of things they had wanted to know for a long time. And they were a little bit disturbed to hear from the Guardians that from the Guardians' perspective, they had not been “proper stewards of this planetary sphere”.

David: Hmm.

Corey: Whatever else information she had gleaned from that interface, she was taken back very quickly with her to this meeting.

David: I don't think anybody would be in a better position than you to speculate what that means. Why were they not good stewards of this planet?

Corey: Well, the Inner Earth groups that . . . I guess, their rationale for the way they have interacted with the surface population that we've discussed, the deception at times, using certain parts of the population as pawns. And not all of them, but certain other Inner Earth groups using surface population as pawns in this ongoing conflict with these what they refer to as genetic farmer races that had come in. And I assumed that there was quite a bit more on that topic that was shared with them.

David: So you're saying because these Inner Earth groups formed an alliance, some of them, from our perspective, were working with the Cabal and were what we would consider negative? And so this is part of why they were told they were not good stewards?

Corey: Right. And of these seven groups, when they were meeting, within the meeting, they were very uncomfortable meeting with each other. Some of them did not like each other very well, and some of them were leaning more towards the Service to Self negative, and some leaned more towards Service to Others, but still, were in self-preservation mode.

David: What about these Inner Earth beings posing as gods to populations on Earth? Is that improper stewardship? Should they not have been doing that, appearing that way, or is that part of their role to help guide us?

Corey: I don't . . . They believe that is their role, and many of the different beings that have called themselves Guardians and have taken part in all these different things believe that's their role. Whether the Sphere Being Alliance agreed, I don't know.

When she left, Gonzales later contacted me and told me that when they left that meeting with the Guardians, the meeting that they had with the Inner Earth Council was the last one that those seven groups had together.

David: Was Gonzales part of that meeting?

Corey: No, no.

David: Gonzales must be freaking out, because you and he are essentially the delegates, THE only contact that they have in the space program, the Secret Space Program Alliance, at least, the only contact they have to this historic event where the Guardians are meeting with the Inner Earth Alliance. And you guys don't know anything about what happens?

Corey: Total silence. Nothing.

David: That's got to make the SSP Alliance really upset, I would think.

Corey: Well, yeah, but the meeting was not about us.

David: Why would you be brought in though? Why would you be brought into something that you can't see, something that you can't hear?

Corey: I don't know.

David: Okay.

Corey: I don't know. I really didn't see the reason for me being there, to be honest, . . .

David: Right.

Corey: . . . but this was an overture to the Anshar and their alliance. They've been having them out to these Kuiper Belt bases for some time. So there's been this political relationship developing for some time.

David: You're saying the SSP Alliance has been bringing out the Inner Earth beings to the Kuiper Belt for some time.

Corey: Right. There have been several meetings that Gonzales had with the Inner Earth groups and the SSP Council Alliance.

David: And you had said when you went into some of these underground caverns like the gardens, that you're seeing classic 1950s flying saucer-type shapes flying around and flying through rock.



Corey: Right. And in that trip, they had actually given Gonzales a ride back in one of their craft to this very base.

David: So my point of bringing that up is that even though we think of these people as living inside the Earth, they could easily travel throughout our solar system anywhere they want to go on their own.

Corey: Absolutely, yes.

David: And beyond, I assume.

Corey: And beyond.

David: Yeah.

Corey: Yeah. They have . . . There are colonies on other star systems.

David: That they have?

Corey: Yes.

David: We haven't heard about that.

Corey: Well, they have, and also the Mayan group, which is going to be . . . They're becoming much more active, and we're going to be talking about them much more in the near future.

David: Do you have any specifics as to where these Inner Earth beings have colonized? Is there any identifiable stars that we would know of that they've actually settled on?

Corey: The only one that I've been told about is the Mayan group, and they are some worlds within the Pleiades.

David: Really?

Corey: Yeah. And they had taken like 40 million of their people with them, and they had done that from the Earth.

David: Why do you think these people were upset by what the Triangle-Head Being told them? What was the twist?

Corey: I guess I wouldn't call it them being a little self-righteous, but they had felt on their own for so long, and they felt like they had been doing the best they could and were doing the right thing. Every time there were cataclysms, they would do what they could to help humanity, even though . . . And a lot

of times, it was in a dishonest or manipulative way. It was . . . I don't know. It was kind of a wake-up call for some of them.

David: I guess what I'm wondering is you've got this veil of secrecy, and you're not able to hear what's going on. And there's this kind of shock and depression to some degree after it's over. Do you think that if these people are being told they were improper stewards, that they were now given a directive that they're going to have to reveal themselves to us as a planet, and that they're actually terrified of this, because they could be killed?

Corey: Right. Yeah. And I was told exactly that in a later meeting by them.

David: Really?

Corey: Days after this meeting, Gonzales communicated that it had not gone well in the Inner Earth Council meeting, that three of the groups . . . And I've been asked not to say which ones, just for operational security reasons – a lot of people can guess one of them. The Omega group was one of them. They left the Inner Earth affiliation that they had.

David: Hmm.



Corey: They left the Inner Earth affiliation that they had.

David: But you said originally that the Inner Earth affiliation was due to lethal threats that they're facing from the Cabal, that the only way they could survive is to pool their resources.

Corey: Right.

David: So what could possibly make them want to break that off, because it seems like it's a choice between life and death at this point?

Corey: It is, but I can't really reveal too much of that without revealing who they are.

David: Okay. So they're just going to go it alone, and they're going to take their best chances with that at this point?

Corey: Let's just say one of the groups also is in contact with an off-world group that has a lot of interest and real estate in Africa. So there are other alliances that they have. They're not putting all their eggs in one basket.

David: Okay. So did anything else happen in this meeting where Kaaree and the delegation are with the Triangle-Head being? They go off. Then you see Gonzales. You have this brief conversation with him. Did anything else happen at that point, or did you just get returned?

Corey: We briefly had some discussions about what was going on in the different Secret Space Program Alliance – some of the scuttlebutt that was going on between the groups.

The Secret Space Program Alliance and the Earth Alliance, both alliances are made up of loosely knit groups, and there's a lot of politics. There's a lot of different agendas. So there's always quite a bit of interesting little scuttlebutt to hear. So we usually . . .

David: Is it something that you can't share with us?

Corey: It's somewhat off topic, but it had to do with military intelligence lower Secret Space Program recently broke away from the Secret Space Program Alliance, and now it appears that they're positioning themselves to be disclosed in a similar way that the stealth fighter was basically disclosed back in, what was it, the '80s. So they are no longer a part of the Council, and the . . . It wasn't . . . The whole group wasn't a part of the Council. There were some key people that were part of the Council keeping them under the narrative that they have been indoctrinated of, you know – that most of the

stuff flying around is human, that there were ETs, but not anymore. It's distant past stuff, and that kind of narrative.

David: Okay, but you just dropped a bombshell, and so I want to make sure that we get this properly talked about. You're saying that the lower-level military Secret Space Program is going to be formally revealed to humanity, and that was part of what he told you?

Corey: Right – in stages. I was told that . . .

David: So are we just talking about the X-37B, the little space shuttle thing that flies up and then orbits the Earth in a year, and then lands again?

Corey: This will most likely be up to the level of the different space stations we have in near-Earth orbit that are probably about 30 to 50 years more advanced than the International Space Station, that they fly to a couple of times a month to service. And they'll probably start off with that type of information.

David: What else could it go into? Do they have the ability to fly around our solar system?

Corey: On that level, they do, but it's not in the short time period that the higher space program has.

David: But that could be disclosed. If this program is disclosed, then what you're saying is that we could be told on a global level that the military has craft that in their own time, which is obviously not as fast as the SSP, that they could travel around the solar system.

Corey: Right. And I've basically been told . . . I was told that there are a number of lower SSP insiders that are being groomed and coached to be unofficially released from their 20-year non-disclosures.

David: Now, why would these people want to say that there are no extraterrestrials, and that it's all us? What's the game plan behind something like that?

Corey: It's a partial disclosure narrative that some of the groups are working to push, and it's already unfolding in front of our face. And, I mean, you can see it in the shows, the commercials.

David: Well, we've discussed - you and I, not on camera yet – but we discussed the shocking “X-Files” pilot episode of January 24th, which airs three days after the CIA does a limited hangout disclosure on their own website. And that “X-Files” episode is basically saying there's hardly any ETs, that it's all us. That's the big thing that Mulder keeps saying, “We've been deceived this whole time. It's man! It's

man!”

So you're saying that that kind of content like the “X-Files” is part of a disclosure narrative that they're deliberately trying to put out there?

Corey: Yes. That “X-Files” . . . That narrative is the exact narrative that most of the space command people had given to them over decades.

David: How could somebody be naïve enough to believe that? I mean, I'm not trying to insult them, but seriously, how could they believe that there are no extraterrestrials?

Corey: I could walk out the door right now and find more people that don't believe them than do, just because of the conditioning from mainstream media.

David: Yeah, but these guys are flying . . . You said they have craft that can fly throughout the solar system.

Corey: Mm hmm.

David: There's pyramids on Mars. There's a face on Mars. What do they think that is?

Corey: Well, they're basically just like what they're putting out on “X-Files” that, yes, sporadic alien contact has occurred mainly in the ancient past, and everything that's occurring right now are alien reproduction vehicles. And that's all that's flying around.

David: Aren't they going to see Secret Space Program assets?

Corey: They do.

David: What do they think that is?

Corey: They're told that they are concept vehicles, not to speak about it, not to put them in the reports or logs.

David: How bizarre.

Corey: Yeah.

David: Well, I do know an insider, who's one of the top guys that worked with Richard Hoagland, and he believes this whole thing, absolutely. And it's kind of shocking.

Corey: I've had people ready to punch me in the face that they're at the top of the pyramid. That's as high as it goes, and yeah.

David: So you have this conversation with Gonzales before you leave, and this idea that the actual lower-level military Secret Space Program will be disclosed, that it's underway – the plan is underway, including these insiders getting ready to be coming forward.

Corey: Correct.

David: Is there anything else that you talked about with him before we get to the next meeting that you had?

Corey: That should pretty much button it up.

David: Okay. So your original meeting that we did a bunch of episodes about of seeing people in the Inner Earth, so said that took place in September. So when was the second meeting in the Kuiper Belt? When did that take place?

Corey: It was in late December, and then early January was the next meeting, where I actually was brought back down to have a meeting with the priestess.

David: All right. Well, let's go into that. So you have a third meeting now with people from the Inner Earth. So tell us about . . . Where does this meeting take place, first of all?

Corey: The meeting takes place in the same area - in the same underground location – but I didn't have to go through all the rituals and stuff.

David: You didn't have to disrobe and get into the little fountain?

Corey: Right.

David: Right. So you were able to wear your normal clothes, not the ceremonial robe?

Corey: Right. We were over in the city area. She was not as . . . She had a different energy about her. I guess quite a bit had happened in between with the alliance that they did have. And the three groups

that left . . . I guess when they left, it was not a very smooth parting. There's a very large disagreement in how to proceed with relations between the surface population and their civilizations.

David: Sure.

Corey: The Anshar had decided that they were going to start slowly communicating with the people that they're communicating with remotely with their minds, reaching out to the people that they had been telling that they were from these different star systems or all these different scenarios. They were going to start telling them who they were.

And the other groups, the three other groups, did not like the idea one bit. They thought it was reckless and would end up in their demise. So they left, and not only did they leave, they stepped up their remote influencing counterintelligence program. They stepped up with the people they were communicating with, making them be suspicious of certain types of information they hear.

David: You're in this meeting with Inner Earth beings, and you're in their city, you said. It wasn't in the temple. And they're telling you now that they're being directed to tell the truth.

Corey: Right.

David: What else happened in this meeting besides just that one detail?

Corey: I didn't get any more tours or anything exciting like that, but we had some . . . it was mainly small talk, and she wanted to communicate how much information they had received from the Guardians and communicate how much of an impact it had made on their community.

David: Hmm.

Corey: It had . . . The way they share information is apparently the way we're going to share information in the future. They've got some sort of a . . . It's like an Internet, a mental Internet, that they're able to access.

David: Telepathically.

Corey: They share information this way. And imagine if you have a data dump like that, that comes . . . They got their data dump from the Guardians, and it hit the whole Inner Earth Internet. So since that time, she said that the various cities . . . It's been buzzing.

David: Well, you mentioned some negative things that they're not being good stewards.

Corey: Right.

David: And you've mentioned that they were told that they had to be more truthful with us.

Corey: Right.

David: So what are they excited about? What's the positive? What was the thing that got them buzzing? That I'm not sure I understand.

Corey: Apparently, they have a new mission or direction. It's appearing as though this new direction and mission is going to be more direct - maybe not more direct open contact, but more direct influence, and in a positive way with the surface population. We may have more open contact with them before we start having contact with non-terrestrials.

David: Was there another reason for these beings, the Inner Earth beings, to be so excited after this contact with the Triangle-Head Being took place in the Sphere Alliance? Do you think part of their excitement was just that they finally have reconnected after this long absence?

Corey: Well, this was a group that they revered, but the excitement was . . . They had received a lot of information, and receiving a lot of information from a group that they had not had contact with ever, but had revered. I mean, how excited would you be right now if you finally got to get face-to-face contact with some of these beings?

David: That's true. So it's the same thing.

Corey: Yeah.

David: So was there anything else of significance that happened in this particular meeting?

Corey: Not of real significance, other than what we were talking about. She did tell me that there's going to be a lot more contact between her and I, and that there was going to be more and more contact with this Mayan group.

And sure enough, this Mayan breakaway civilization group is showing up everywhere. The last time I was at a briefing at the Kuiper Belt – this Kuiper Belt base is one that I've been to a few times now – I had never seen them there. They were there. They were wandering around. And Gonzales says he's

starting to see them all over the place. So I guess they are starting to take some sort of a larger role. And what that role is, I have not been totally briefed on yet.

David: Well, this is really fascinating, and I thank you for continuing to suffer through all the incredible stuff. You had helicopters circling your house five times. A black helicopter buzzed my house. And you're hanging tough. You're still here. You're still doing the show, so I really thank you for participating

Corey: Yeah. The day after I had a SSP meeting, about . . . it had to do directly with the Lower Secret Space Program, my house got orbited five times by a Chinook helicopter, and I got it all on video.

David: Yeah. Well, thank you, **Corey**, and thank you for watching. This is "[Cosmic Disclosure](#)". Fascinating information as always, and we'll see you next time.

Cosmic Disclosure: Personality Metamorph Program

Season 4, Episode 9

David Wilcock: All right. Welcome back to "[Cosmic Disclosure](#)". I'm your host, **David Wilcock**. We're here with **Corey Goode**. And in this episode, we're going to get into one of the most sensitive secrets of the Cabal, that known as the Personality Metamorph Program. This is an extremely important subject for everyone to understand because, well, I'll let him tell you the rest.

Corey, welcome to the show.

Corey Goode: Thank you.

David: So we know in the public lexicon that there are people out there that some people call sociopaths, some people call them psychopaths. There is a myth that a psychopath is violent, but that's not always true, is it?

Corey: No.

David: So what are some of the characteristics of the sociopath that we would see just in everyday life? If you have a sociopath that's part of your life, what are some of the characteristics that that person might display?

Corey: Well, usually it's not going to be any shock or mystery to you – a complete lack of empathy for any type of emotional or physical pain that you're going through. That's a major sign. The way they behave towards animals and children is a good indicator.

A lot of these people have learned to blend in pretty well. Sociopaths have learned to fake emotions or fake empathy. So some of them are not as easy for the average person to identify. Until you've spent time around them, a lot of them can be hard to identify.

David: Do you agree with the commonly held notion that these people tend to be glamorous and narcissistic, that they're kind of affable and personable, outgoing, extroverted?

Corey: Exactly. Yes.

David: Give us an example of a nonviolent everyday sociopath that would have those kind of characteristics.

Corey: It would be your basic con artist that would get what they want from their mark without using physical violence, using manipulation, but having no empathy or care about what their successful con will do to the people emotionally or financially.

David: Do you think that society is starting to become more aware that these people exist?

Corey: Yeah. Well, it's been pretty obvious for some time, but with social media, the Internet, the topic is pretty heavy out there. People know about Internet trolls, they know about sociopaths and what they're doing to this world, usually from places of power.

David: I think it's interesting that the conventional statistics, in case you don't know watching the show, is that it's 4% of men, 2% of women, but when you get to sociopathic Internet trolls, different studies I've seen ranged between 5% to 8% of all people on the Internet are acting this way. Why do you think the Internet is such a marvelous breeding ground for trolls and for sociopaths? What is it about it that they like so much?

Corey: The illusion of anonymity. Very few of these people would behave that way in front of the people they're chastising or attacking. Most of them just don't have the guts or just couldn't deal with the consequences. So they feel empowered by the anonymity of the Internet. And we've, of course,

done an episode on the government troll centers that I've helped set up, where paid government trolls get online and cause all kinds of problems.

David: Well, we also have Stockholm syndrome, right, where people that have been kidnapped in hostage situations end up agreeing with the philosophy of their kidnappers and thinking that it was a good thing that they're participating in a good cause by being hostages.

Corey: Yes. These programs that get lumped under the MILAB umbrella, or you hear the MKULTRA umbrella that people like to use, they don't realize that MKULTRA was a program that developed a lot of techniques that were later used in a wide range, hundreds of other programs. So all of these other programs are not MKULTRA, but MKULTRA developed a lot of tactics that are used.

The people that run these types of programs in the screening process, when they bring these children in, they separate them out based on the test results. And for some of the programs, they require people that are sociopaths, and they identify them as young as possible. And the program we're talking about today, they also want people who are compulsive liars and also have intuitive empath abilities to where they can read people and manipulate people.

And then they take these people and they put them in the program that I always heard referred to as the Personality Metamorph Program. And they developed this Personality Metamorph Program to be a program that would train these children over a period of time, through their adolescence and into their young adulthood, to be the best manipulators and infiltrators ever trained on this planet.

David: Mainstream psychology says that the two main characteristics of the sociopath are fearlessness and dominance. So they use the term fearless dominance. How do you think fearless dominance . . . How do you think this characteristic of not having fear and this characteristic of being dominant, how is that useful in a program like the Personality Metamorph?

Corey: The whole purpose of these assets is to manipulate people, control people and infiltrate organizations. And not only that, have the people that they're manipulating and controlling develop a very strong bond with them to where if they don't talk to them for a few months, they're wanting to talk to them. They want to spend time with them. It's very odd.

One of the strangest things about it is that the people that were training these children, these children as

they were getting into adolescence were getting so good that the trainers could not control them. The kids were manipulating them. They just could not totally handle them. So they brought in intuitive empaths to work behind glass and help them tell – they would wear an earwig – help them tell when the subject that was going through the Metamorph Program was being deceptive or truthful or manipulating the person that was doing the training or debriefing with them. So they were very, very difficult to manage and control.

David: Why do you think these people are fearless? I mean, most people feel afraid about all kinds of things. How does a person actually get to this point where they don't have fear at all?

Corey: Well, a lot of times some of these children have been put through incredibly horrific experiences to where they shut off their feelings and emotions. Some of them are born that way. They're born just for some reason they don't have the right chemical balance, but for some reason they do not have the normal emotional response to situations that we do.

David: Well, just to bolster what you're saying, let's take a look right now at an A and B shot where the A shot, as you're seeing now, is a normal brain, and the B shot is the brain of a psychopath or sociopath. And what you're noticing as you look at this is that all of that greenish-yellow color that's all over the brain of the normal person, that color is missing from the frontal lobes of the brain in the sociopath.

So why do you think the frontal lobes are not showing any electrical activity in these people's brains?

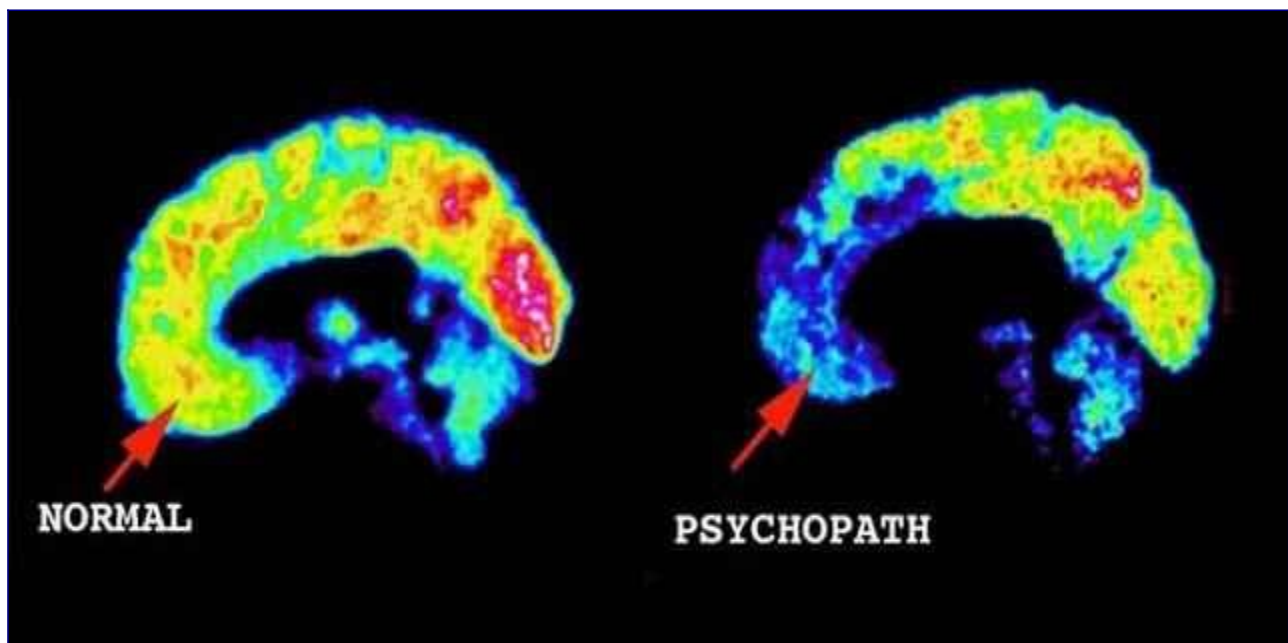

Corey: Well, that's where a lot of these emotions and thought processes occur.

David: So their brain literally does not have any, or very little, electrical activity.

Corey: Electrochemical activity in that region.

David: So it's literally as if they've shut down a whole area of their brain.

Corey: Right, and that can happen through psychological trauma or it can be a biochemical thing from birth.

David: So is that some kind of defense mechanism against further trauma, like the body adapts to the trauma so that you can just plow through it?

Corey: In the cases of people that had to disassociate so many times. This has happened in rape victims and other assault victims that have been repeat victims. They've disassociated, disassociated, disassociated to a point to where that part of the brain just shuts down and quits producing impulses. But that's just a certain portion.

David: Another thing that we hear about sociopaths when you read about it in pop psychology all the time is that they are invariably going to be thrill seekers. They're constantly in a fight against boredom, and they need adrenaline. They need thrills of danger to make them not feel bored.

Corey: That definitely was a problem with these metamorph children. They would fight among themselves. They would take crazy chances. I mean just to set it up for you, one of these tests that some of them were put through, they would dress a young man up and make him look very, I guess clean cut, put him in like a pink polo shirt and some blue jeans and make him look real preppy, drop him off at the roughest biker bar in town and leave him. And by the end of the night, he would leave riding a motorcycle with a lady on the back.

The situations they would put these people in and how they would turn them around was just absolutely amazing

David: But what are we actually seeing this guy do when he goes into the bar? Obviously, if he goes in dressed like a prep, people are going to want to beat him up or kill him.

Corey: Right.

David: So how the heck does he get out of that situation?

Corey: Well, they call them a personality metamorph for a reason. They can size up a situation and totally change their personality, the way they talk, have a backstory, I mean, everything very quickly. Probably come in and say, "I'm so glad to be here among my people. I got the wrong suitcase." You know, whatever they have to do to socially engineer the situation. And they're very good at it. And these people they've used for infiltrating the military, intelligence, finances, all branches of government, every part of the economy with corporations, and within the very community that we work in right now, UFOlogy.

David: Most people when they lie, a good police officer can tell signs of lying. People will do the long blink while they're talking to you or they'll start to fidget with their hands or something like that. Are these people able to lie and beat a polygraph or beat a typical person who's trained to detect lying?

Corey: Yes. They had to poll an intuitive empath to be able to finish their last four to five years of training because they were so incredibly gifted at any type of lie detective technology that was in the programs, which was quite sophisticated. And the people debriefing them would just, after a while, they realized, "We can't trust what these people are telling us." They had a lot of problems, and they had to have a solution of bringing IEs in to try to help them tell when these people were deceiving them in briefings or briefings after training, briefings after these little spot missions to test their skills.

And finally, they'll sit there with an earwig and if you sense deception, which was almost all the time, a tone would be sent to the person with the earwig, and the person would know to change his approach to the subject across the table that was in the program.

David: So when we hear the word "metamorph", personality metamorph, why was that term chosen?

Corey: Because they can morph their personality to match any other clique or group that they're around, or even individual. I mean there's the typical thing that everybody knows that salesmen do, comen do, emulate the person that you're trying to influence, sit like them, do body language with them, do subliminal things. This is way beyond that.

These people, their skills are way beyond that because they are intuitive. They're reading the people, so they're drawing off of the information that they're pulling from the people intuitively and all of the other things, reading body language and micro facial expressions, watching the eyes to know exactly

how to approach them, as well as immediately size them up before even talking to them and know which accent to approach them with or what backstory to approach them with like that.

David: Do these people receive neuro-linguistic programming training?

Corey: They receive all types, all kinds of training when it comes to counterintelligence, intelligence, all the different types of ways of manipulating people. I mean everything from the simple things of reading body language in the context of also marrying that with your intuitive feedback, as well as there is some electromagnetic enhancements and training that I've talked about in other episodes that is more of the training that a lot of the rest of us used.

In these programs, these people would use a wide variety of other technologies that other programs used, like information or technology that would feed information directly to their neurology, sort of like an education. And also they would put them in virtual reality environments to train them in the skills they were trying to instill.

David: I can't help but feel like when you're describing personality metamorphs that you're describing politicians running in an election. And without getting into any specific names, there's fairly widespread knowledge about muckraking journalism where these politicians will go into different cities, and they are talking in the accent of the city that they're in. So how . . .

Corey: Those are old, old, well-known tactics, but those are very small caveats compared to what these people are trained in.

David: Are politicians trained in the Personality Metamorph Program, or is this not really their specialty?

Corey: There are personality metamorphs in politics, but not all of them are trained in the Metamorph Program, no. They are just . . . I would assume that most of them are people that the Personality Metamorph Program wish they had gotten when they were younger because they would be perfect candidates.

David: So you mentioned something really quite incendiary, which is that these people have been trained very thoroughly with advanced technology and that they have infiltrated the UFO community.

Corey: Oh, absolutely.

David: Without getting into any names, because we don't want to attract that kind of karma and that kind of attacks from their fan bases, but what kinds of things might we see if this were happening?

Corey: Well, and it's not always getting in a limelight position. A lot of times they will become a friend of someone in the limelight position or a friend of a friend in the limelight position to get access without having the spotlight on them.

David: What good does that do?

Corey: Well, they have access to the person that they are sent to be a handler for and infiltrate their small little clique and put in a narrative or break up an organization, any number of directives that they're given. And that's just one small part. UFOlogy has been infiltrated since the beginning, in the '50s, by the intelligence organizations. But the Personality Metamorph Program has been deemed one of the most successful infiltrating programs ever. And I can't remember the name, but there was a Russian infiltration program, spy program, back in the '80s, I believe, that was known for being one of the best infiltrating programs. But this makes it look like child's play.

David: Was this part of the KGB?

Corey: Yes.

David: Okay.

Corey: Yeah.

David: You had tossed out a term that I think we ought to double click on for a moment. You said 'socially engineering'.

Corey: Social engineering.

David: What is that?

Corey: That's a term that's often used in data security, personal security. People will call you up on the phone, pretend to be the bank, and say, "I need your bank account number real quick, and, oh, what's your social?" That is a real quick of what social engineering is. In the context of the personality metamorph, social engineering is they come in and do the same thing on a much wider scale, and detailed scale, based on a personality profile they've developed on you in a very short period of time, a very specific tailored approach to influence you.

David: So there's all these people out there saying that the Earth is flat, and they feel like they have very compelling evidence and it's the biggest cover up of all time. Have they been socially engineered by personality metamorphs in some cases, the people that are coming out with this and believe this to be true?

Corey: Personality metamorphs will hop on a bandwagon and definitely help promote it. I've heard a couple of different people now say that that particular narrative came directly from NASA, I believe. So I don't think that was . . .

David: Not meaning that it's true.

Corey: Not meaning that it's true.

David: To thoroughly discredit people who are in the truth community . . .

Corey: Right.

David: . . . by making them seem so ignorant that they're pre-Columbus era, where Columbus sailed around the Earth and found new land, that they don't even believe that.

Corey: Right.

David: So it's like they've literally figured out a way to use this technology so much that they've made a total mockery of people to such an extent.

Corey: Right. And one of the main goals that the personality metamorphs and other infiltrators have done with the esoteric and UFO community is to try to fragment us as much as possible through inner fighting and strong belief system differences.

David: You're saying that public figures in the UFO community would get a handler. They're not aware that it's a handler.

Corey: No.

David: What do they think they have?

Corey: They think they have a new friend that is very charismatic, that gives them insight into themselves that they hadn't seen before and has a wisdom about them that is unusual for their young

age. And they want to spend time with them, therefore giving the metamorph access to them and their psyche.

David: You had mentioned to me in private conversation before that personality profiles are made of people, psychological analysis that's extremely detailed. So if you don't mind, could you explain how the personality metamorphs use those and how are they created?

Corey: Well, the personality metamorphs are not looking at a dossier of a personality profile. They're taught to size up a person and profile them on the spot, and with their intuitive abilities and after they've been put through so many simulations and the technologies we talked about before, and then in the real world testing, they become very confident of their skills, and they're very accurate with their profiling.

David: In the case where psychological profiles are created on people, because you said that's one of the most important tools for an intelligence agent, what do they look for? What would be in a profile?

Corey: The baseline is personality types. There are 16 main personality types. And when you have these personality types, you can then build off of that by gleaning information about what magazines they get, gleaning information about where they go on the Internet, information dipping into their medical records. You gather all this information. If they talk to a psychiatrist, you gain information to that. And then it's compiled by behavioral psychologists that do nothing but put together personality profiles.

David: Is it common for personality metamorphs to betray the people they're handling at some point?

Corey: Absolutely.

David: And how does that manifest?

Corey: Usually at the pinnacle of when they have the person in the palm of their hand. And if that is there . . . If their job is to destroy that person or discredit that person, they get the target completely disarmed to where they completely trust the metamorph. They may tell secrets that they normally wouldn't tell to this metamorph. And they'll be like, I don't know why I'm telling you this stuff.

And so this metamorph now is getting more and more and more power over this other person. And the dynamics in the relationship are slowly changing. And once they reach a certain point, then the

metamorph can either drop some information, drop a bomb, or step off the scale and let the target go through disillusionment and withdrawals from the personality metamorph leaving their life.

David: So is the personality metamorph going to come across to someone as like the best friend that they've ever had because they have this technology?

Corey: People become addicted to these people's personalities and friendship. They become addicted to them.

David: Will the information that they give that metamorph under the guise of this best friendship appear on the Internet in seemingly disconnected ways, where, "I don't know how this got out, but not there's all this stuff about me on the Internet?"

Corey: It depends on what the operational goals are for that metamorph. Usually they're penetrating, infiltrating to gain information to report back or to cause a rift in relationships or organizations.

David: Are these personality metamorphs also used in the Space Program, and if so, for what?

Corey: In the Space Program, I did not run into the personality metamorphs. They were used mainly for Special Access Programs down here on Earth. And as I said, they were inserted into just about every walk of life, every part of life from government to banking, everything.

David: What is the best way that you or anyone could identify that this is being done to them, and what kind of countermeasures can you take? What's our defense against people that are trained this way?

Corey: Well, the best defense is to know that you need to guard your inner information and guard information that could be harmful to you at all costs. If you're in a situation and you've met someone new through a friend, or a friend of a friend, and they like the same hard to get soft drink that you do, oddly. They happen to like this offbeat band that no one else has ever heard of that you do, and all these just little coincidences occur and y'all become good friends, and you find yourself becoming somewhat addicted to wanting to be around them all the time, and you find yourself wanting to tell them things that you wouldn't normally tell anyone else, red flags should go up a little bit.

And it's only after you have really started to share information and made yourself vulnerable to these people that they then start the actual manipulation of you.

David: Are personality metamorphs being directed against people who are having spiritual contact with orbs or dreams and visions, synchronicity, and then talking about it on Facebook or on the Internet?

Corey: Yes. Yes. And any other number of targets, including financial people who need to be controlled or managed. A lot of times, they'll go in and control or manage people.

David: What is the greatest weakness that these personality metamorphs have that we could use to defend against them?

Corey: Their own hubris. They underestimate everyone. They are convinced that . . . They're very intelligent. They're convinced they're the smartest person in the room. They're always convinced that they're the smartest person in the room. The people that . . . If you learn to sit back and keep your ears open and keep your mouth closed, which is hard for a lot of people, you will learn a lot more, and you will look around and perceive a lot more, and you might start noticing these people.

David: Do you think there are always going to be little warning signs that the addictiveness of them being like your best friend causes you to overlook, that if you are really being careful, you'll find these little tells – these little giveaways – that something's really wrong?

Corey: If you didn't know that a personality metamorph existed, you wouldn't think to guard against it or to be careful of it.

David: Right.

Corey: It doesn't exist. It's just a person that apparently came into my circle somehow, was psychologically damaged, very intelligent, manipulated me and my friends, split up a business venture or a relationship, and then they disappeared from our lives. And that's how they may think of it, when actually it was an operation.

David: Well, my opinion is, too, that there's always going to be clues with the sociopath in general. You're always going to have things that don't feel good, but the addictiveness kind of sucks you in.

Corey: Yes. And you need to learn to go with that inner voice, that feeling. When something doesn't feel right, usually in the beginning there's just a little bit of something that doesn't quite feel right that people don't listen to usually.

David: All right. Well, that's all the time we have for on this episode of "[Cosmic Disclosure](#)". I'm your host, [David Wilcock](#), and as always, I thank you for watching.

Cosmic Disclosure: The Earth Alliance

Season 4, Episode 10

[David Wilcock](#): All right. Welcome back to "[Cosmic Disclosure](#)". I'm your host, [David Wilcock](#).

We're here with **Corey Goode**, the insider's insider, and in this episode, I'm going to get into some very interesting stuff with him regarding the opposition to this Cabal, the Earth Alliance, the people who are on the front lines here on the ground trying to bring about a peaceful society or maybe not. So that's one of the things that we have to talk about.

Corey, welcome to the show.

Corey Goode: Thank you.

David: When people start to get into this subject about things like 9/11 online, there is such a widespread, pervasive sense of paranoia, despair, fear and hatred of the Cabal. Is there an opposition going on to the Cabal that goes beyond bloggers?

Corey: Absolutely. Every single enemy they've created over the hundreds of years, every group they've alienated, every atrocity they've done to these countries over these hundreds of years, has finally built up to a point to where they all came together, loosely came together.

All of them have their own cultural pains, and I guess some of them have different agendas on the retribution they would like to see exacted on the enemy, which we're calling the Cabal. Others would like to just maybe have a few changes. They think a world government is inevitable anyway, and the Cabal was wanting to do it in an evil way, so why don't they co-opt it and do it the right way?

Despite many of these alliance groups having different agendas and ideas about what should happen to the Cabal once they overcome them, they've put aside a lot of differences, and they've come together for a common goal, which is to defeat the Cabal.

And this is the key of why the Cabal had been so successful. They are made up of many different

syndicates of people with many different belief systems and agendas, but somehow they found a way to work together. The 0.01% of them have found a way to work together, even though a lot of them really don't like each other, to exact control over the Earth.

Well, the Alliance is following the same playbook, getting together with people they wouldn't normally work with, forming a loose alliance, and trying to, or actually are in the midst of, overthrowing the financial system that this Cabal has set up for the last 100 years and want to replace it.

David: So I think people that are investigating this have felt that the Cabal control central banking in every country. They have bribed or compromised all of the leaders in every country. The leaders are blackmailed, and therefore even people who are fairly compassionate and reasonable folks, there's a widespread belief that this Cabal has just penetrated every country, all aspects of society. So what do you say to those people when they hear about the idea of an alliance and they, "I just don't believe it?"

Corey: Well, there is an alliance, and it is true that this Cabal is a master at infiltration, and, indeed, they have infiltrated elements of the Earth Alliance. And, you know, this is a problem, but, like the BRICS Alliance . . .

David: You're talking Brazil, Russia, India, China, South Africa is the BRICS.

Corey: Right, they've gotten together, and they've created pretty much a new world bank and financial system to compete with the Western or Cabal banking system.

David: And you're talking about the Asian Infrastructure Investment Bank, or AIIB.

Corey: Right. Over time, countries like China have been slowly purchasing the debt and also natural resources from countries owned by the Cabal as their financial Ponzi scheme has slowly, slowly started to collapse.

David: Now, we've heard that China is actually holding – the official numbers, I guess, are in the neighborhood of \$2 to \$3 trillion, but the unofficial numbers are \$4 trillion of US bonds and US debt. That apparently is greatly superior to the wealth that's left in this Federal Reserve, Cabal-oriented, Western world.

Corey: Well, there's very little gold left here. There's a reason that all the big banks right now are buying silver like crazy and stockpiling it. There's very little gold left in any of the vaults that are supposed to have gold in them.

David: What about Fort Knox?

Corey: Same story. It's pretty well known that there is very little, if any, gold at Fort Knox.

David: Well, Germany asked for 3,000 metric tons of their gold back from the US, from the Federal Reserve.

Corey: Until we quietly told them we didn't have it.

David: And, yeah, the answer has been, "Oh, well, maybe in 100 years we'll be able to pay you back." So is it a Ponzi scheme that at this point is just based on printing money out of thin air? Is there any real collateral left?

Corey: It's all zeroes and ones and computers at this point. How all these different bubbles have not collapsed already is beyond me.

David: Are you the only one that feels this way or do others in the Alliance feel this way as well? What have you heard?

Corey: Well, I've heard that with the latest negotiations, members of the Alliance are now wanting to come in and not allow the Western dollar and the Western financial system to totally collapse, but to get to the brink of collapse and then move in and buy it at a cut rate and annex it into their new financial system. And, you know, everybody's been hearing for years and years now the promises of debt forgiveness, jubilee, and money that will be given to people specified on their age, how many dependents they have, and that kind of a thing.

And people have heard that so much now they scoff at it, but this is something that is openly discussed in these meetings. So it is a part of the discussion and the negotiation.

The revaluation of all the currency that is being discussed is very controversial, and most of the people do not like it. The poorer countries like it because a lot of them want to value all currency the same. Now that would put the US and even China and other countries at a major disadvantage in trade, but

that is one of the things. Or when they're talking about equaling the playing field, they're talking about changing the value of all currency to being the same.

And even inside the Earth Alliance, there are groups that do not like that plan at all, and they want a sliding scale based on GDP and a bunch of other numbers and information that – I'm not an economist – I really don't understand. I was having all this information thrown at me, and I don't understand the economic jargon, but the bottom line I was understanding.

David: Are you aware of the Alliance being in possession of surveillance footage that's very compromising of the Cabal?

Corey: Yes.

David: And what forms does that come in that you're aware of?

Corey: Every form. They've got everything from emails, texts, phone conversations, videos, audio recording. They've got satellite imagery of things that different people have ordered and real time ima . . . I mean, they've got everything.

David: So it's entirely possible that members of the US military could be hired to go through that footage and try to pick out the best of the best.

Corey: Yes, that would be quite a job. With all of the data mining they have done to accumulate all of that data, I can see why they would need the help. It's quite an undertaking to go through all of that.

David: Probably one of the most basic questions that people are going to be asking is, why in the heck is this whole thing so mysterious? Why can't the Alliance just say, "Hey. Here we are. We're going up against the Cabal. Here's our announcement. Here's what these guys are doing, and just start openly talking about it. Why are they having to keep everything so secret that people, even this late in the game, they are still doubting guys like you and me writing about this stuff online. Why won't they just come out and say what they're doing?"

Corey: I would say they pretty much have been coming out and saying what they're doing. The question is, why isn't the Western media covering it?

David: Well, give me an example of how they're coming out and saying what they're doing.

Corey: Russian, alone, has been coming out with all kinds of information and openly threatening the US with releasing all different types of information that they have gathered, you know, including 9/11. They've threatened to bring forward proof that 9/11 was either an inside job or that the US knew it was going to happen and sat back and did nothing. There is quite a bit going on that the Western media is not reporting or they report in a tongue-in-cheek way.

David: Well, do you think that at this point, the Cabal still has such a control over world media? Since their television networks are worldwide, the movies go worldwide, do you think that they can both create propaganda very easily that defeats any Alliance initiative and that they can, furthermore, kill anyone who starts trying to speak out from the Alliance at this point?

Corey: They have a waning control. They used to have a complete control, but the Earth Alliance group . . . You're starting to see more and more interesting content pop up on television that normally the Cabal would not approve to be on television, you know, different movies. I mean, the list would go on and on. So, yes, they did at one time have full control of this media, but obviously that control is slipping. Their control over everything is slipping, so we're going to see more and more of this information coming out.

Now the big thing that has been going on in the secret negotiations between the Earth Alliance and various Cabal groups is how to release information, and they're pretty much in agreement to release information in a slow manner. The main reason they want to release information in a slow manner is that a lot of the data that has been accumulated, that we were just talking about, is damaging to both sides because both sides have done criminal things in the past. And there are no clean hands in these negotiations.

David: You told me in private conversation that Gonzales has said to you that in the future this struggle that we're in between the Cabal and the Alliance right now will be seen as World War III.

Corey: A stealth World War III.

David: A stealth World War III.

Corey: Yes.

David: So how do you get a world war without any open obvious invasions or major military conflicts going on?

Corey: Everything's being fought through digital means, through hacking, cyberwarfare. It's being fought through proxy armies such as the Cabal using organizations they created, like ISIS and al-Qaeda, and through a financial war that's going on. It's something that could very easily spike into an open, hot conflict in certain areas, but this has been an ongoing, stealth world war for a period now.

Gonzales basically said history will look back on this time as a different type of world war, and this will be a stealth World War III.

David: What about the idea of natural disasters and weather being involved in this war? Are there technologies that you're aware of where weather can be manipulated as part of fighting this war?

Corey: Both sides have weather modification, and it was heavily being used in open warfare against each other. That's slowed down some. They're still using it, but it's slowed down during the negotiations.

David: What would that look like? What would we see in the news that would be an example of this war being fought?

Corey: Well, with the weather modification wars, you change air streams that pull the moisture out of your area, dries up the breadbasket of your region that grows all of your food. You know, that type of thing . . . or inundates you with hurricanes or heavy rain, which can then lead to other natural disasters that cause you to declare a national emergency and put all your assets and focus on that problem.

David: Well, one of my favorite ones was when the South American Alliance first convened, they declared that Chile was going to be where their headquarters would be, and on the day that Chile was supposed to start their role as the headquarters of the South American Alliance . . . It was never recorded in the Western media. The day that Chile starts as the headquarters, they have this massive, massive earthquake.

So are you aware of earthquake-making technology as well? Could these earthquakes be part of it?

Corey: It's the same technology, yeah.

David: Yeah. So you're saying both sides use this against each other?

Corey: Absolutely. And that's not the extent of it. US Navy, many years ago, discovered super volcanoes that are below the ocean, and those have been kept secret for some reason.

David: Similar to what we hear about with the whole Yellowstone caldera?

Corey: Exactly, and apparently they have placed some sort of charge or energetic device that could cause it to erupt. There are three of them that I saw documentation on, and that is one of the threats that the Cabal is making. You know, they're acting like a child. If we don't get our way, we're going to break all the toys and leave.

And so there are still a lot of really tricky negotiations going on down here, and these are going on right now. They've been going on for months and months, and they're working on a consensus of what they're going to release data-wise. And at this point, they agree that a partial disclosure is where we should go and that humanity should be slowly acclimated to the greater reality of our true existence and receive a slower roll out of some of these advanced technologies.

David: Is there a plan for a large number of people to be arrested at once? Does it have to be that way in order to prevent them from escaping? How do you think this whole thing is going to play out?

Corey: Well, right now, I don't know. There are going to be arrests and prosecutions, but the extent of which depends on these current negotiations. They are obviously going to go after the people they hate the worst in the Cabal. We use the analogy, how are they going to just let part of the genie out of the bottle? And I think they're trying to figure that out right now. They're not going to let these groups that have raped and murdered the planet get off scot-free, but elements within the Earth Alliance also do not want to have people hanging from lamp posts from the street.

There are a lot of groups. There are a lot of different ideas among the groups in this Earth Alliance, and for them to reach a consensus is going to be difficult. And then for them to negotiate with members of the Secret Earth Government Syndicate that are coming to the table to negotiate because they want out too. They're ready for it to be over too. They have quite a distance to bridge before they get to where they want to be. And that's going to give us in the community time we need to get a grassroots effort going to demand Full Disclosure and the full truth.

David: Do you think that the controlled media could be given new marching instructions once this takes place? What will media look like in the aftermath of some kind of . . . if the mass arrest thing happens, as an example?

Corey: There will be a bunch of people that are just as shocked as us sitting in front of microphones. They do not know the extent. When they find out, I don't know if they're going to be able to speak on air, but, yes, eventually when the truth embargo is lifted and if the media is going to be the delivery mechanism, I can imagine they're going to have quite a different demeanor when they're given the news. Otherwise, it might just be the televisions. All stations might be taken over for a while, and the population be given a massive re-education about our true past.

David: Now some people who watch this show and are into this might be aware that laws have been openly passed in the US. They did it during Christmas while everybody was having dinner and happily with their families. It's openly now a law that the US government can seize all of your assets in the bank in the event of having a financial crisis.

Corey: Right. All deposits legally before that already were legally owned by the bank. When you take your money and deposit it at the bank, it is legally owned by the bank. That was before that even. When I worked at the Federal Reserve, that was explained to me, and that was in 2008.

David: But when you go into the bank, every bank usually has a little FDIC logo somewhere, Federal Deposit Insurance Corporation. And it used to be \$100,000. Now it's up to \$250,000. It says right on there, your deposits up to \$100,000, or whatever it is, are backed by the good faith and credit of the United States government. Ha, ha.

Corey: Ha, ha. I didn't know we had that.

David: Yeah, so if the US government faction of the Cabal gets in trouble, are they going to actually try to do that? Are they going to try to take people's money out of the bank? Could there be a period of time where no one can access their money or their bank accounts have been basically deleted?

Corey: That's been their plan all along. Whether that actually occurs or not, I am not positive at this point. A lot of what I thought was going to happen is up in the air right now because of the current negotiations.

David: Let's just say, if people are watching this show, something like this ends up happening, that could cause a very great outrage, obviously. If an event like that takes place, does that mean that people's money is lost forever? Or does the Alliance have contingencies in place in case the Cabal temporarily tries to say, "Oh, you don't actually have money in the bank. It's all ours."?

Corey: Depending on the plan, some people would lose what they had, and some people would gain something that they didn't have. Like, maybe if they rented a home for 10 years that belonged to a person that was a real estate investor that had 50 homes, that home might be deeded to the person that had been renting it or a property. These are all the types of things that they are negotiating and discussing. It's incredible.

I mean, it's all up in the air, and every contingency they have a plan for, but how things play out are yet to be seen.

David: The Alliance is not as shaky as some people might like to believe, correct? I mean, if we have a significant part of the US military and intelligence apparatus involved in this, this is a very significant operation we're talking about.

Corey: It's a significant operation with a large coalition of loosely-knit groups, some of which are syndicates, secret societies from the East. Some of them are groups that the news here will tell you are foreign criminal organizations. So it's a very complex topic. The organizations are loose-knit, and not all of them have the same, I guess, values or agendas. And you can see how much of a mess it is in the midst of these negotiations right now.

David: Are we now talking about a majority of the world that is the Alliance compared to the Cabal? How much of the world do you think the Cabal still has some control over?

Corey: The majority of the world is not controlled by the Cabal any longer, but the Earth Alliance, quite a number of the groups have been infiltrated by this Cabal group. So there also is a very tricky question.

David: Do you think that 9/11 truth is going to be an element of what happens as the Alliance makes its move, one way or the other?

Corey: I do. I do.

David: What do you think people are going to hear? If you want to make a prophecy at this point, put it on camera before this has actually happened, what are some of the things that people might be told once this all unrolls?

Corey: Well, like I said, I have no inside knowledge of 9/11, but I think they will be told the details behind 9/11, the truth of who planned it, who executed it, and who knew the details of the operation after it was executed. And that would be shared, and the obvious outrage among the people would want us to be tracking these individuals down and hanging them from lamp posts.

David: Since we only have a couple minutes left now, someone watching this might feel like they want to help this process come about. We've had, for example, militia groups saying, just tell us what to do when the time comes. We'll go where we need to go, which obviously is kind of a violent thing that we don't want to be involved in. Should people be grabbing guns and trying to go shoot people? I mean, what can they do? What should be done? What shouldn't be done?

Corey: They've tried to foment racial tension.

David: They – the Cabal?

Corey: The Cabal. They've tried to foment racial tension. They've tried to foment tension between patriot groups and the government. They want that to happen so they can declare martial law.

David: Right.

Corey: Don't play into their hands. You cannot get, as I say, a positive from a negative. As we've stated over and over, it's going to take all of us coming together and forming a grassroots movement, having uncomfortable conversations with people that will look at us like we're crazy, and begin to educate people now.

David: All right. Well, you heard it here. I'm very much looking forward to this coming out in the open. I'm sure you are, too. This is “[Cosmic Disclosure](#)”. I'm your host, [David Wilcock](#), and I think you for watching.

[Cosmic Disclosure: Viewer Questions Part 4](#)

Season 4, Episode 11

David Wilcock: All right. Welcome to “[Cosmic Disclosure](#)”. I'm your host, **David Wilcock**. We're here with the insider's insider, **Corey Goode**. And in this episode, we're taking your questions. So this is the chance where, if you've been participating in the discussion forums, writing comments in the comments section, we go through and we find things that look interesting to discuss here on the show.

So **Corey**, welcome to the program.

Corey: Thank you.

David: The first question that we have is: “How can one find out if he or she has been infected by the AI?”

Corey: Well, that's not something that they're really going to know unless they get tested by a particular instrument that is used by the SSP. They use it . . . They put it close to your . . . by your electric field, and if it measures more than one signature, then they know you're infected. It's not something you can test for anywhere down here.

David: I think to double-click on that question a little bit, what they're really asking too is, how prevalent is this AI infection in regular humanity? Is this more of a Space Program problem? Is this something happening to people here on Earth?

Corey: People will have the infection, but if they're of no operational value to the AI, then it's not going to stay dormant in them. It's going to move on.

David: So the AI isn't just going to inhabit someone if it doesn't have a reason to?

Corey: Unless it's biding its time until . . . using them as a host . . . until it can get into some technology or another person that's its real target.

David: Why might a person on Earth be useful to the AI? What would be an example? Because some people are going to think they're involved in a huge cosmic drama, and that they're very important to this thing and the AI's going to be in them.

Corey: Well, the AI may use a person as a host just to hang out in their bio-neural field until they find a better host that's going to get them into the electronics that they want to be in. Let's say an aborigine happened to find a piece of a ship, and they messed with it, and they got infected. Then it would hang

out in their bio-neural field until they passed it along to other people. And eventually, it got into someone who uses technology, and then that person is their conduit into technology.

David: So it sounds like what you're saying is that the AI would only even be interested in people here on Earth if they could get into the right technology.

Corey: Right. You're more of a vehicle.

David: Is there going to ever be a case in which the AI could use someone other than to pass itself into technology here on Earth?

Corey: Well, if people have key positions, a lot of times they'll be infected with actual nanites. And these nanites can either be programmed, or they can be remote-controlled by the AI signal.

David: The next one we have is from Alston Bell. A-L-S-I-O-N Bell. I think I'm pronouncing that right. Inner Earth peoples and the harvest. Now, just for the context of the question, if you haven't read "The Law of One", when they use the term 'harvest', they mean ascension. It's the term used in the Book of Matthew for ascension.

"If the Inner Earth people have been here for 17 to 18 million years, have they never been harvested? Have they escaped being harvested? Do they not also want to progress?"

Corey: Well, they are actually fourth density already. And they have remained on the planet to assist the planet and us.

David: So fourth density meaning they are ascended beings?

Corey: Right. And they're basically . . . They're supposed to be stewards of the planet and all of its inhabitants.

David: And given the fact that they've been here for this long, I just want to reconfirm that time changes when you go from density to density, right?

Corey: Yeah, they experience time differently than we do. They perceive and experience time differently.

David: What would that equate to in our conventional understanding?

Corey: Like, we may refer to time in decades, and a decade to us seems like quite a long time. In a decade, we'll see wrinkles and gray hairs appear.

David: Right.

Corey: That's not the case for them. So 100 years to them could be easily like maybe one to five years for us.

David: So you're saying that their lives, the way they actually perceive their life, 100 years could be like a year?

Corey: Right.

David: Isn't it strange, though, that they could talk to you and then the time of the conversation is the same?

Corey: Well, yeah. You'd think that maybe there would be a time dilation effect, but I guess with them being a higher density being, they're able to reach lower a lot easier than we can reach higher.

David: So they could alter their flow of time to be able to speak to you, potentially.

Corey: And possibly alter our flow of time, or our perception.

David: So it's possible that you could be going into an accelerated time field, but then you're just regressed back when you are returned.

Corey: Right. But that's speculating because I'm not exactly sure of the particulars of, you know, how they were phasing me in and out of time.

David: Now, part of the ascension is the solar flash, and I think another thing this person was asking about is how have they avoided these big solar flashes, these solar energy releases?

Corey: Well, I don't know if they have, necessarily. They're affected by all the same energies that we are, . . .

David: Right.

Corey: . . . and all of the beings that are trapped here in our solar system are going to be affected by them.

David: All right. Are you ready for another one?

Corey: I am.

David: Okay, this one's from Azgard123. "When **Corey** came back 20 years in time and was debriefed, did the authorities in charge get the full debriefing of his service that was yet to come?" And then the question goes on to basically say, "Did they know what was going to happen to you after they brought you back?" In other words, if you're up there in space, and you do 20 years into the future, do they also see the timeline of what's going to happen to your life once they bring you back to Earth for the ensuing 20 years?

Corey: Well, I know they have the capability, but logistically, for every single person, I don't know if that's practical to look . . . but you know, you'd think that this being such an important secret to keep, that they would. So I really don't know the answer to that. But when I did return, and after my debriefing, they did know that they were going to be observing me very closely, and they did call me back for recall work from time to time.

They would call me back and have me work with other people, blank slate me, and put me back in my normal life that I had built post 20-And-Back.

David: I think what this person is also just trying to find out is, how much is the Cabal aware of what's happening in the future? How much do they get to plan it all out, map it all out? In other words, why didn't they know, for example, that you're doing this show? Why couldn't they see that?

Corey: That's a good question, because they use a type of AI technology to look at probable futures. And that's . . . We've heard all these things about the Cabal's about to fall, the Cabal's about to fall, mass arrests are coming. Well, they've used this technology to stay one step ahead of all these programs that were meant to take them down.

So honestly, I don't know why they didn't intervene or see this previously, unless there was another intervention preventing them.

David: Is it possible that the mere act of trying to look at the future changes the future?

Corey: Yes. It's just like when scientists observe an experiment, they change the experiment. They affect the experiment by observing it.

David: So even if one or two people know that something might be happening, that could alter the outcome.

Corey: That's possible, yeah.

David: Right. Okay. That's a question we could do a whole episode on, but we're trying to get through your questions here. Let's go with Ron Mayor 2012. "Blank slating members of the 20-And-Back Program. What is the Guardian Alliance members' view on blank slating? Is this something that the Guardian races support, or is this something only the Illuminati space program controls, and possibly unenlightened yet highly technologically advanced ET races do? So, in short, what is this view on the blank slating process?" Is that allowed by the benevolent beings in the universe, or do they just have to kind of let it happen?

Corey: Yes. Their non-direct interventionist kind of policy that they follow so strongly prevents them from stepping in and preventing it from occurring. But I have never . . . When I've spoken with like the Sphere Beings, that's never been a topic. We've never talked about, you know, this is unethical, immoral, and it shouldn't be happening.

For the second part of the question, the negative ETs and their proxies, all these different Illuminati, all these different names that we use for them, they definitely are all about using the blank slate technologies. And for them, it's just a standard operating procedure.

David: Okay, we have another one now from Pastel Galaxy Z. These are some very colorful names. I can kind of imagine that as I see it. "Missing people off-world slave system. Are our people being pawns and slaves for Reptilians and maybe other human-like races?"

Corey: The interstellar or intergalactic slave trade, human slave trade is . . . it's very complicated. A portion of the people that are taken are handed over to Reptilian beings, but these people are a commodity, and they're traded off to many other civilizations as well who use us for many, many different purposes. The Reptilian beings use us for very dark purposes that most people know about.

David: What about the human-like races?

Corey: There are a lot of human-like races out there that do participate in the slave trade with the ICC (Interplanetary Corporate Conglomerate) and different factions of the Secret Space Program. But I

don't normally . . . I don't think they're consuming the people, the slaves that they're receiving, like the Reptilians.

David: All right. Next question we have is from WM. “Were the primary inhabitants of Mars back then the same species as the one they warred with on Maldek, or a different species?” Now, I guess the first part of this question has an assumption in it, which is that Mars and Maldek actually warred with each other. So let's just start with that first, and then we'll get into the rest of this. Did you have information saying that Mars and Maldek actually warred with each other?

Corey: That was a part of the conversation I had with Kaaree in the library, that she stated that, yes, there were two different groups, and one on Mars and one on Maldek, and they were in conflict with each other. Now, I may have assumed that they were different species. I don't recall that she specified that they were different species, but that was my assumption. I thought they were different sizes. I mean, that's just what . . . When we were interfacing, that was the imagery I was getting. But they very well could have been the same that were just . . . there was some sort of civil war. So I don't know the full answer to that. I know that they were doing battle with each other, but I do not know if they were the same people.

David: We could argue that if the Super Earth is very large and Mars is very small, almost a moon, that if they arose indigenously on those planets, they probably would be of very different sizes.

Corey: Yeah, different gravity, barometric pressures are going to dictate how large and the bone density, and all that.

David: Okay. So I think we got a good handle on the first part of this question. Let's go on to the second part. “What extrasolar species and/or organization arrived to destroy the empire built by those on Maldek? Did they settle our solar system too, or did they turn around and leave? Were they the precursors to what became the Draco empire, or were they a different group?”

Corey: Well, the information I received was that after these - the factions we were talking about, you know, Maldek and Mars, when they were having this war, they hacked into the defense grid and were trying to use these weapons against each other. And in doing so . . .

David: Wait, wait. What do you mean by the defense grid, first of all?

Corey: The defense grid that the Ancient Builder race had put into the local and entire local star cluster, like about as close as 50 or so stars.

David: And what form would that defense grid take if we were looking at it?

Corey: Well, many of them were spheres that were offensive/defensive weapons.

David: Like large metallic spheres?

Corey: Well, I don't know. I don't know if they were metallic. A lot of times, they would hollow out or use a moon, and then convert it.

David: Like with the Death Star.

Corey: Right.

David: Yeah.

Corey: I've seen information about some of the spherical moon-like structures out there having signs of . . . having a hole or external structure that's covered now in a lot of dust and regolith and stuff.

David: Okay. So then what you were saying was both Mars and Maldek were trying to hack into these death stars?

Corey: Yes, to use in battle against each other, and in doing so, this is how . . . One of these is what destroyed the Super Earth. And when they did this, they brought down the defense grid that the ancients had put up – the Ancient Builder race – that had protected these local star clusters.

David: You're saying the people of Mars destroyed the planet right next to them?

Corey: We don't know. Most likely, that's what happened, unless . . .

David: Wouldn't that be, like, an astonishingly ignorant thing considering the damage it would cause to them?

Corey: It would, yeah.

David: Destroyed their planet.

Corey: Hindsight's 20/20.

David: But you think that it was the people of Mars that struck against Maldek and ended up destroying it?

Corey: Right.

David: Interesting.

Corey: Well, I mean, it was the . . . both of those people, the information I received, were hacking in and trying to use that technology against each other. And that technology is what destroyed Maldek. And I would assume that the enemy destroyed the planet, and they didn't destroy their own planet.

David: But this question also talks about out of our solar system groups.

Corey: Yeah, and that's what I was leading to. And once the defense grid dropped, that's when these, what they call genetic farmer races, began to come in. Some of them compromised the Super Federation, and also this is when the Draco Federation came in and really started to wreak havoc in not only our solar system, but the local star clusters.

David: So in your information, then, this war between Mars and Maldek did not involve any third parties, did not involve any outside groups?

Corey: I did not hear any third parties come in until after the defense grid dropped - after they hacked it. Yeah, they basically screwed up big time, and we're paying the price.

David: Is it possible that that did happen, but that you just didn't have access to that information?

Corey: Oh, yeah. Absolutely.

David: Because I have had other insiders say that the Maldek group, in particular, was widely trying to go around and conquer other worlds, and it was not just local.

Corey: Well, I'm talking about the local star cluster here. You know, this local star cluster of 50 stars was protected by the same defense grid, and there is travel within the local star cluster. You know, if they're warring with another planet within the local star cluster, I mean, that could have occurred. But I don't . . . I didn't see information on that personally.

David: Okay. Okay. I have had other people tell me that they were doing a lot of wars with local stars.

Corey: And I've heard information like that from other insiders. It's just that I didn't personally see or hear that.

David: Okay. Next question is coming from Gym Rat 89. "Do you know the truth about the Rh negative bloodline, specifically O negatives, or do you have any info on this?"

Corey: That was discussed when I was assigned to the research vessel. And the Rh blood thing, they joked around that the elites brag and talk about the Rh bloodline, and they joked around that they actually had found that in monkeys.

David: Right.

Corey: So how evolved could it be if it's an alien bloodline type, our blood type? So the people in the SSP that were doing the genetic work and that kind of stuff really didn't put a whole lot of stock in it. They kind of pooh-poohed the idea. They kind of considered it more religious hyperbole kind of stuff that went on amongst the different religious beliefs in the different Illuminati occult groups.

David: Can you just clarify what the Illuminati religious belief about the Rh protein in the blood is exactly?

Corey: If I'm right . . . and most of what I've heard has been after I got out, of people constantly asking me about . . . you know, saying that it's from a royal ET bloodline or an engineered ET bloodline.

David: Okay. So when you have the protein, that means that you have the ET bloodline?

Corey: That's what a lot of people assume or believe.

David: Okay. So the next question we have is from Flyer. "A super planet with some trillion inhabitants. What is this disease of control, power, violence, and destruction, and where does it come from? I don't get it. Is all of this negative behavior the result of AI and/or these Archons or inorganic beings?"

Corey: Well, that is definitely a part of the equation. A lot of it, from what was explained to me by Kaaree from the Anshar group, the Inner Earth group, was that a lot of it is the social programming that we go through, but we also have genetics that were brought to this planet from these refugees from Maldek and Mars, in stages from like almost 500,000 years ago up until, I think, 60,000 years ago, more recent.

And as they interbred, that was a dominant gene, and this gene was an aggressive gene that is behind a lot of our problems of aggression, jealousy, greed. And it's something that a lot of groups are not sure we can overcome.

David: To get to the core, though, I think this person is just having trouble understanding why anyone who's a biological life form would have a desire to be negative, to dominate, to control, to kill. Maybe you could speak a little more to when you've had conversations with the most ascended beings like the Sphere Beings, what is the Sphere Beings' sense of why this negativity occurs? What are these beings after? What do these negative beings actually want? Why are they doing this?

Corey: Well, I had to spend a lot of time with some of these negative people, and it seemed like they had some hole in them that they couldn't fill. And you could see the darkness in their eyes. There was a hole in their soul. They couldn't feel emotions like we do. Somehow by causing other people to feel the emotions that they couldn't, they were drawing energy and, like, sort of trying to fill this hole.

That doesn't really seem to make sense, but, I mean, these people are . . . I mean, they're sociopaths. They're extremely . . . I mean, they're alien to us. If we interact with them, they can put on a good face and pretend to be normal, but if you spend a lot of time with them, you get to learn very quickly that they're almost not human. It's really hard to try to compare a person who has empathy for other beings with a sociopath.

David: I think that's a pretty good answer. Let's go on now to Ced Guru, C-E-D G-U-R-U. "I'm interested in the giant people. I have to say I'm disappointed that these advanced people were fighting wars with each other. I've heard it over and over. We all have. But it's only sinking into my brain now as a truth. Is that just how it is with all people? They taught us wonderful things, but also the art of war by example? Did we inherit wars that have been fought since long ago, and are we still fighting through the original reasons that may have been forgotten by most people?"

Corey: Absolutely. We're still fighting battles from further back than 500,000 years. And we, the people on Earth, are sort of proxies for these refugees that came here and run things from the background. They cause us to fight proxy wars on their behalf against their enemies, and we're just pawns.

David: This person's disappointed that these wars are being fought. And they said, "I've heard this over and over. Is that just how it is with all people?"

Corey: With all people on the planet?

David: I think with people in the universe.

Corey: Many of them may have had this in their past. Many of them didn't have the aggression. It seems like there are some civilizations that progress very quickly because they got along. You know, they were communal, and they maybe were . . . They had a very similar look and species on the whole planet. They weren't divided and fighting each other. The Earth is a little bit different. I mean, we've got a very interesting genetic mix, and it's also what makes us coveted by a lot of these groups that are taking us into the slave trade.

David: Well, I just want to point out, and as you already know, my new book, "[The Ascension Mysteries](#)", the subtitle is "Revealing the Cosmic Battle Between Good and Evil". The whole book is about the wars that have taken place in our solar system. And combining what you said with all the other insiders I've spoken to, all the research that's available, from the research I've done, would you agree with me on this? Benevolent civilizations tend to be the norm once you get past a certain point. It's not like this is happening all over the place.

Corey: No, no. I mean, there are other planets like ours that have been tinkered with and didn't naturally progress that are in similar situations as us.

David: Right.

Corey: But it's not the norm.

David: Yeah. I think that's the core of the question. So we're not . . . It's not like it's this hostile, negative universe, and the only way you grow is through pain and torture. That's just something that might have happened here, but it's not by any means what usually occurs.

Corey: I think difficulty, a little bit of pain and torture is a catalyst for progress.

David: It does seem to be authorized by the universe that these things happen. "I'd like to ask **Corey** if he knows about the connection between the people in the Inner Earth and legends, histories, and mythologies about gods and angels on the surface."

Corey: Yes, that is definitely something that came up in my meeting with Kaaree down in the library. And myths are full of truth and carried through oral tradition. And different things will happen to

change the narrative, but usually, there's a core truth in there somewhere. And Kaaree told me that the Inner Earth people over oceans of time had come to the surface after major and minor cataclysms and kick-started civilization again and provided laws, agriculture, and that kind of stuff.

But when they appeared, they would either let the people keep the assumption that they were gods, or some of them would actually say they were gods. And they did this, they say, for operational security, because they wanted the people to look up instead of below their feet for their location. So, definitely, they're not . . . I wouldn't say that these Inner Earth beings are the root of all of these myths, because some of these are non-terrestrials that have come down. So it's a mix.

These ancient gods, these myths that we hear, it's a mixture of the Inner Earth people and non-terrestrials that have also come down and done the same thing. And often, they're both visiting the same culture, the same civilization intermittently, giving them information. So they'll have two different gods visiting them. One will be a non-terrestrial, and one will be an Inner Earth group that will come and visit them from time to time.

David: So let's just talk about one example that I can think of and that's Greek mythology. Now, some of the stories about people on Earth mating with these gods, their children do incredible stuff. I mean, like Hercules, this guy's able to lift incredible amounts of weight. He has incredible running speed. He has superhuman powers. So when we start to hear about these superhuman capabilities, do these Inner Earth people have those kind of powers? Do they have superpowers?

Corey: Yeah. They have ascended abilities. It's not something that they demonstrate like parlor tricks for you when you visit.

David: I see.

Corey: That's kind of taboo. But they do have abilities that would be god-like if we were to observe them.

David: Did you see anything yourself that would be evidence of that?

Corey: Well, the mind meld with Kaaree was evidence enough for me.



Their technology alone seemed like magic. You're walking around – there are no lights – but you have full spectrum 360° lighting everywhere you go.







They have the huge gardens and caverns.

David: Well, you also saw that library where the chairs were levitating.



Corey: Right, right. And I mean, just your average person in the world right now, if they were to be pulled down there to the Inner Earth and saw someone sitting in a floating chair, they're probably going

to think, “Oh. This is an angel.” Or whatever their religious background is, they're going to pull from that.

David: Right. That's a very fascinating answer. So we've had a lot of fun with this. I hope you've enjoyed it too. We'll be back next time here on “[Cosmic Disclosure](#)”. I'm your host, [David Wilcock](#). We're here with **Corey Goode**, and thank you for watching.

Cosmic Disclosure: Celestial Timeline

Season 5, Episode 1

David Wilcock: All right. Welcome to “[Cosmic Disclosure](#)”. I'm your host, [David Wilcock](#). I'm here with **Corey Goode**, and in this episode, we are going to get into the cosmic history of our solar system. We're going to go through the actual timeline of who settled here, and what are the pieces of information that we have, because we've had a lot of different things, but we've never really tied it all together before. And we're going to try to get you from the beginning to now, and fill in all the cracks of what **Corey** firsthand experienced in the Space Program.

So **Corey**, welcome to the show.

Corey Goode: Thank you.

David: So if the universe is 13.8 billion years old, the Earth formed four billion years ago. It cools down for liquid water 3.8 billion years ago. That's when microbes first appear. So we know that's going on.

We know the Earth was a watery planet 3.8 billion years ago. So theoretically, somebody could have landed on it that far back, but what do we know about the actual habitation of our solar system? What's the tangible evidence? What's the oldest stuff that we know about?

Corey: Well, according to the smart glass pads, the tangible evidence that is around is in the form of ancient ruins. And they begin to label these ruins as the Ancient Builder Race ruins. And they weren't able to accurately date them because they were so ancient that it was in the hundreds of millions, if not billions, years old.

David: So you're saying that these ruins appear, and you said they were excavated? They're digging stuff out from where? Where were they excavated from?

Corey: On different planetary bodies in our solar system anywhere from Venus all the way out to the Oort Cloud.

David: So they were sometimes underground. They'd been buried, and they had to be dug out.

Corey: Yes, sometimes they're deep. Sometimes they're on the surface covered in debris, and sometimes they're deep inside whatever planetoid or planetary body that they're excavating.

David: So what are we seeing with these ruins? What do they look like?

Corey: Well, they were finding a lot of the, what we described as, a transparent alloy, aluminum-type alloy. This was also a technology. They were finding that . . . I guess, they were impregnating this alloy with other small technologies that could make the glass go opaque or dark or maybe even display technology. So it was pretty advanced technology. And a lot of the times, they didn't know what they were finding at first. Sometimes they were finding stone-like artifacts that turned out to be technology, but they didn't understand what they were finding.

David: And what's the timeline when these were first being discovered?

Corey: I believe . . . Being discovered off world . . . They were the German breakaway groups that were beginning space travel before and during World War II were locating these things.

David: Okay. What are the buildings struc . . . We said they're made out of transparent aluminum, but what do they actually look like? Like if you're seeing something that might be billions of years old, what do we actually see when we fly over it or come up to it?

Corey: A lot of these that were on the surface looked like they had been through some major blast waves. They were twisted, bent back. They were not pristine by any stretch of the imagination. They were . . . I mean, they were a mess. The ones that they would find below ground or ones that had been covered prior to whenever this blast wave happened, or whatever occurred to cause the damage, would be more preserved.

But they were having . . . There was a lot of mystery. They didn't know who the Ancient Builder Race was - where they came from. They weren't able to find any writing.

David: Well, let's just get into . . . Were their domes? What do the structures look like – the ones that were not blasted?

Corey: Yeah, there would be all different . . . There would be collapsed domes, rectangular structures, that were . . . and towers, or what used to be towers standing. There were a lot of different shapes and sizes of structures.

David: And you'd mentioned before pyramids and obelisks.

Corey: Yes.

David: A lot of those?

Corey: Yes, and most of those were found underground.

David: Inside the Inner Earth stuff?

Corey: Inside not only the Earth, but on some of these planetary bodies, they were finding them inside, finding rectangular and pyramid kind of shaped facilities or outposts.

David: So the pyramid shape seems to have been important to these people?

Corey: Yeah, apparently. And when I was reading the smart glass pad, I really didn't understand sacred geometry and all of the stuff that I've learned since from watching "Wisdom Teachings" and other things. So I didn't understand the significance of it back then. And I don't think they did either. If they did, I didn't see it displayed.

David: Richard C. Hoagland's top insider, who I've been calling Bruce, told me that, "We live in a cosmic junkyard." That's the way he talked about it.

Corey: Yeah.

David: And I didn't really understand until what you're saying now why he phrased it that way. It's all really smashed up stuff on the surface, huh?

Corey: Yes.

David: It doesn't look very attractive.

Corey: They have to really search to find anything of use.

David: Wow! When we're seeing smashed transparent aluminum, it's glass-like, but when you say it has a burnt appearance, does it look like there's char marks on it, or what's the nature of the damage? Does it still look like glass but just all broken?

Corey: Some of it. Some of it will still look like glass, but it's so ancient that it looks . . . I mean, it's just very brittle. It's not transparent anymore.

David: If it's on a moon, does it get like regolith on it like moon dust?

Corey: Yeah, right.

David: So it's all covered in dust?

Corey: Right.

David: So you might not even know that you're seeing something that's twisted and turned over.

Corey: Your eye will pick out that it's not something natural, but you'll really have to look close to see the detail a lot of the time.

David: Okay. Now you had said something to me right when I was finishing the book, because this whole topic that we're discussing now, the whole second half of my new book, "[The Ascension Mysteries](#)", goes into this in great detail. And you blew my mind, because we've been talking about this, but I've never heard you say this until we were doing that briefing talk for the book. What happens when we go out of the solar system?

Corey: They find the exact same thing in what they call our local star cluster, which is a group of stars that is around 50 stars in our area that are connected by this cosmic web.

David: Right. And I'll just point out that when I did the research when you told me about this, I found some interesting things. So I want to ask you a couple questions on that.

Local cluster - because this is an important part of our history when we get into the Ancient Builder Race. These stars in our local cluster, they have some bizarre interaction, you were saying. So could we get into what that interaction is? What makes the local cluster different? How do those stars behave with each other as opposed to the stars that are further away from the local cluster?

Corey: They behave sort of like a . . . It's kind of weird to say this, but not really a group consciousness or hive kind of thing, but they're all connected on a deep energetic level with each other, and so are all of the beings that are residing in those star systems.

And apparently, all of these different star systems in this local star cluster were under protection of this Ancient Builder Race. And they had some sort of protective grid up, and they left. The Ancient Builder Race disappeared, and this protective grid was up for millions to billions of years.

David: Okay, but we're . . . I don't want to miss this one point because it's so significant. The local cluster is the stars that are nearest to us. When did our guys first have the ability to leave the solar system with a craft, first of all, that you know of?

Corey: They've had the ability since probably the '20s and '30s.

David: So even the German breakaway groups could leave the solar system. There was no barrier or technical problem stopping them from going elsewhere.

Corey: Right. Well, no technical problem, but it's not advisable to hop around to these different star systems without making the political connections first.

David: You could get shot down if you show up?

Corey: Yeah. The Germans were pioneering and making a lot of these connections.

David: Well, you had mentioned before the idea that there's a partial disclosure timeline that the Cabal was going to try.

Corey: Right.

David: And one of the elements of that partial disclosure timeline, from what I remember us talking about, is that they're going to try to sell us on the idea that they haven't left the solar system, that there's some problem. What's their idea? How are they going to try to sell us on space travel, but then you can't leave the solar system?

Corey: There's several scenarios I've heard, but yeah, one of the scenarios was that they were going to try to tell us about the Ancient Builder Race, tell us maybe that ETs existed at one time, but they never come around here anymore.

David: Right.

Corey: And we've developed technologies from reverse engineering, and that's about it.

David: So the bottom line is that in order for us to travel to other star systems all the way back in the '30s, there has to have been very early along an understanding, I assume, of the cosmic web, or are they portaling to these stars? Or are they traveling . . . Did they have super light speed travel? How were they doing it?

Corey: Well, it's a combination. They were traveling through portals in the beginning. That was the main travel. And when they developed craft, and they were developing these torsion drives, they then had superluminal travel.

David: Okay. And when did this superluminal travel come in?

Corey: They had superluminal travel back before World War II and through, but the United States was behind the German secret society groups and some of these secret groups that had been developing these technologies. They were decades behind.

David: Okay. Well, I think this is an important context, because when we're talking about the solar system history, some of these partial disclosure timelines do apparently involve them trying to tell us there's an energetic barrier, or there's some kind of problem or radiation or something that prevents them from leaving the solar system.

So when we did leave the solar system, when we did get into star systems, and we were not shot down, how much of this Ancient Builder Race stuff did we find? Did we find it on planets, moons? Did we find it in satellites floating around? Exactly, what . . .?

Corey: They found . . . Almost identical to what they found here, they found in other star systems in our local star cluster.

David: And you said what they found here is all over the place – all the moons, all the planets that are solid. They're just loaded with stuff.

Corey: Right.

David: So this is huge to me, because what you're now saying is we have this star cluster, 50 stars or more. They all have planets, or most of them have planets. And everywhere you go, it's the same stuff. And is it all equally ancient?

Corey: Yes.

David: And it's all smashed like it was here? Or is it . . .

Corey: I don't know.

David: Or do we have more damage here? Okay, you don't know.

Corey: I don't know. I don't know a whole lot of the details about what was found in other star systems. I would not assume that it would be exactly in the same condition here because of what happened later.

David: All right. So you're saying that the planets in these star systems were governed by this ancient Builder Race. They were essentially protecting them. What form does this protection take place? Is there some sort of physically measurable technology or artifact associated with that protective grid that you'd mentioned?

Corey: Yes. The delivery system for whatever protection or weaponry that they had was in the form of giant spheres the size of moons, almost the size of planets. And they, in most cases, were moons that were hollowed out or carved out, excavated, and then they were used, built out as stations. And in some of them, they've shown signs of having outside holes, being giant moon-sized outside holes. I mean they're huge.

David: So you can actually see that it's metallic or some sort of structure . . .

Corey: Yes.

David: . . . just by looking at it?

Corey: Well, I've heard reports of it. I haven't seen the images myself, but . . . And I don't know exactly where those were.

David: How many of these would there be in a given star system within the cluster?

Corey: I don't know.

David: But it's more than one, right?

Corey: Oh, yeah.

David: There's multiple "Death Star" moons in any given cluster.

Corey: Right. Right.

David: So this is truly a staggering discovery. It goes so far beyond what I had thought I knew up until recently, and it just shows to me the power of asking you a question you already knew the answer to, but I just never thought to ask the question before. Because now, this Ancient Builder Race thing, it's much bigger than just something that happened here in our solar system. We're talking about a huge amount of development. And the size of that population . . . Do you have any idea how many people there were?

Corey: No idea. It was a very large civilization. There is so little known about it. It was a big question mark.

David: Right.

Corey: And they knew that it was an advanced technology. They really wanted to acquire the technology that in the beginning we didn't recognize as technology, but once we did, we started going out looking for it big time. But, yeah, whoever they were, they disappeared, and then other groups came in. And any writing or any type of information that would give us history was removed, just like kings come in and wipe away the writing of the old king, the history.

David: Okay. Now, the next thing that I'm aware of from Hoagland's insider, Bruce, is he said the newest information is that Earth's moon was put into position around the Earth 60 million years ago after the fall of the dinosaurs, and that it is a gigantic civilization inside the moon.

Did you personally encounter information about the moon being 60 million years old?

Corey: The information . . .

David: That it was positioned 60 million years ago.

Corey: The information that I read on the smart glass pad, from what I remember, 500,000 years ago was the timeline that I seem to remember the best.

David: Right. Bruce said that was the prevailing theory up until recently, and now they've had new information that makes them say the moon is 60 million years old.

Corey: His information's probably updated from the information I was reading.

David: Yeah. Did you ever hear about the moon being called an ark?

Corey: Yes.

David: Okay. So do you think it's possible that this new interpretation of the moon's age, that perhaps, the dinosaurs were deliberately destroyed by the asteroid, and that life was seeded from the moon, that the moon had a whole bunch of life in it that they then put on Earth?

Corey: Yeah, that was a speculation that it was not an accident, that the asteroid that wiped out the dinosaurs was not happenstance. It was directed.

David: Do you think that that might have partially been because of the Raptors, that there was a nasty intelligent dinosaur that developed?

Corey: That's unknown, but from the experiences that I've read reported with the beings that moved underground that have developed into the Raptors or whatever, that wouldn't surprise me.



David: So if we go with the 60 million-year-old moon and that it was an ark, would you say that it was like a used car, that it was kind of old and broken down by the time they drove it over here?

Corey: Yes. This is technology that was hundreds of millions, if not billions, years old. And there were other civilizations that know about this technology. They really want to acquire it, and they're hijacking it all the time.

David: So the moon could be driven like a car through the cosmic web. Theoretically, when it's in its prime, you could drive around with it, take it where you want it to go.

Corey: That's consistent with what I read.

David: Do you think that there's enough space inside the moon that it could bring a whole planet worth of life from one place to another?

Corey: You know, it depends in what form they brought it. If they brought it in the form of DNA and then came here and cloned it, maybe.

David: Right.

Corey: Kind of like we have that DNA bank, ark that we're starting.

David: Sure. So if someone came in with the moon 60 million years ago, then that could account for some of these discoveries we read about in the Thompson and Cremo's book, "Forbidden Archaeology", like this chain that's found in 220-million-year-old rock, that kind of stuff.

Corey: Yeah, it could be. And then there's a lot of ancient civilizations that have risen and fallen on the Earth over millions of years that some of their artifacts could have found their way into some weird places over the years as the ebb and flow occurs on the surface through all these changes that happen.

David: So I guess the next thing in our timeline would be the Inner Earth civilizations, and that, you said, starts when?

Corey: Well, at the time, we really didn't have much information on them in the smart glass pads. It wasn't until more recently that the Inner Earth groups claimed to have been here almost 20 million years.

David: Right.

Corey: So that is more recent information.



David: And are they saying that they came from other stars within our local cluster?





Corey: They're saying that they developed on our planet, that our planet is . . . that all planets develop life. That's what they do, and that they are a product of our planet creating life.







David: Okay. So let's now go to the next big thing after Inner Earth civilizations. We have them showing up. They're telling you 18 million years ago at the oldest, but this didn't all happen at once. It wasn't like they all appeared at the same time, right?

Corey: Right. Yeah, there were different groups. Some of them were as recent as like 28~30,000 years ago.

David: Oh.

Corey: I mean very, very recent. And the different groups, they went back like 250,000 . . . I mean, they were different lengths in time. And they looked different.

David: Right. So do we have any information about when different groups showed up? Or does it not get that specific?

Corey: It doesn't get that specific until we move into the Super Earth and Maldek or Mars.

David: Okay.

Corey: And we're getting around 500,000 years ago. There was information that there was some sort of conflict going on. Looking back, it seems it was a conflict going on between Mars and the Super Earth. And one of the groups had hijacked or hacked into one of these, I guess you call them Death Stars,

moons, and they were trying to use it as a weapon against the other side. And in doing so, this is when the Super Earth exploded, and it brought down the rest of the grid in the entire star cluster.

David: If the grid is down, what happens? What's the effect of that?

Corey: Well, when the grid came down, all of these other groups that had stayed away, because they were not going to come anywhere near this defense grid – it was very advanced. Once the grid came down, it was open range. They came in and started interfering with all the civilizations in the local star cluster.

David: So the explosion you say took place 500,000 years ago?

Corey: Approximately, yeah.

David: What's the first group that comes in?

Corey: We believe it's the Super Federation groups that came in, that started coming in first. And the Super Federation is made up of all kinds of groups. So members of the Super Federation, different members, started coming in about 500,000 years ago. Immediately . . .

David: So right after

Corey: Right after.

David: Right.

Corey: They were monitoring. They knew it happened. They came in. And then about 375,000, 365,000 years ago, don't really know, that's when they say the Draco came in. So the Draco came in at the same time that we have waves of what they call refugees coming here from survivors of this big catastrophe that brought down the grid, destroyed the planet. So we have a lot going on. So it starts to become pretty convoluted and confusing at one point.

David: So when did the earliest refugees from the exploded planet . . . because it's not just a planet, right? They had colonized our solar system.

Corey: Right.

David: They have stuff all over the place. So it can't be that all of them got wiped out when the planet blew up.

Corey: Right. And according to the information I had at the time, which now your new information calls into question, the moon arrived with survivors in it.

David: Right.

Corey: And the information I read said it was around 500,000 years ago, almost immediately after the catastrophe.

David: So we have these people living inside the Earth. We have refugees coming to the Earth. We have Mars destroyed and Maldek destroyed at the same time. When we get into “Law of One”, it describes that the first third-density life on Earth was 75,000 years ago, and that it started with people that were reincarnating from the Mars destroyed civilization.

So “Law of One” describes three cycles of 25,000 years and that there's catastrophes at the end of each cycle. So we have a civilization rising and falling kind of scenario. So is that how you see it as well that there's . . .

Corey: Yes. And what was mentioned to me by the Inner Earth group, the Anshar, is that there were major and minor cataclysms that were occurring throughout these cycles.

And after the Super Earth exploded, for quite some time, there was debris flying all around our solar system. And debris from that super planet flew out all the way out toward the Oort Cloud, and then it was pulled back in by the sun. And we're in all these strange orbits, and the debris would end up hitting the Earth and other planets. This occurred for some time. It was crazy in our solar system for a while. It was like billiards.

David: So since we're doing a timeline here, I guess Lemuria might be another thing that everybody's going to want to know about. When did . . . Did you hear anything about a civilization in the Pacific Ocean thereabouts?

Corey: I'm sure the information was in there exactly where they were, but this was awhile ago that I was reading this. But it was telling pretty much the timelines and what they were finding.

David: Anything about a civilization in the Pacific?

Corey: Yeah, there were . . . On just about every continent, there were civilizations that they found traces of.

David: Okay. So in this timeline, if we're zipping through Lemuria, I guess that brings us up to Atlantis next. So let's talk about . . . Do we get more information? Does it get easier to trace what's going on once we get into the Atlantis period?

Corey: Well, a lot of the information . . . There were books that had a lot of information in them that were scribed back during this time period that these secret society types had access to. And this is information that was heavily guarded, and I think you've talked about some of the information like they even had bloodline information going back many years.

David: Right.

Corey: So a lot of this information was kept in these secret books that now are in the Vatican and some other secret places.

David: The amount of warring civilizations that we see in the Hindu Mahabharata is one interesting thing to look at. It appears that there were multiple groups on Earth at one time openly having advanced technology and warring with each other. Are you aware of a similar situation from what the smart glass pad said? Was there a time where you had various colonist groups all warring and interacting simultaneously on Earth?

Corey: Not only on Earth, but in the solar system.

David: Okay.

Corey: Yes. Even on the moon, there are areas where up until fairly recent times, in our current accepted history timeline, that there were wars. And those areas are left as a memorial or a reminder of the wars. And then some sort of deal was struck to keep those types of wars from occurring again.

David: Okay.

Corey: But there were open wars and conflicts even in the skies early in our current era.

David: So we're dealing with a very complex story. It's not something that can be easily condensed down into one thing. When we're talking about the civilization of Atlantis, is that a conglomerate group of different civilizations, actually, and not just one?

Corey: Yeah. That's what was explained to me is that we've kind of taken the name and overlaid it on a couple of civilizations. The civilization that was due to an asteroid that came in and caused the great flood and all of that, was, I think, the one that most people associate with actual Atlantis.

David: Right. When we're looking at Native American literature, and we're seeing these various benevolent gods showing up to people there, and this is obviously something that's going back to people rebuilding from Atlantis, having been destroyed, who are they and how do they factor in? Because this seems to be a worldwide thing that happens after Atlantis' flood.

Corey: And it seems that these gods that were coming back, bringing back civilization, were a combination of different non-terrestrials and people that we're calling Inner Earth groups.

David: Okay. All right. Well, I think we've got a pretty good view now of the history from how it started up until what most people are familiar with from conventional research sources. So **Corey**, I want to thank you for bringing all this information to our attention. And I want to thank you for watching. This is [Cosmic Disclosure](#). I'm here with **Corey Goode**. I'm your host, [David Wilcock](#).

Cosmic Disclosure: Remote Viewing and Influencing

Season 5, Episode 2

[David Wilcock](#): All right. Welcome to “[Cosmic Disclosure](#)”. I'm your host, [David Wilcock](#). I'm here with **Corey Goode**. And in this episode, we are going to be exploring some of the technologies of consciousness that have been used in a variety of contexts, both here on Earth and in the Space Program. We're going to be talking about remote viewing and remote influencing.

All right, **Corey**, welcome to the program.

Corey Goode: Thank you.

David: So the conventional view of remote viewing that most people are familiar with started – at least, when I first heard about it - it was on the “Art Bell Show” in the late 1990s. That he had guys coming

on there like Major Ed Dames, who was saying that he was training people in remote viewing. And you had Joe McMoneagle, who supposedly did documentaries in Japan where he reunited people with their kids and remote viewed the location of the kid, brought them together, and then they filmed it on camera.

So what is that basic type of remote viewing that most people are familiar with from those paranormal shows? What's happening there? What are they actually doing?

Corey: Well, everything in time and space is connected. And we can use our consciousness as a vehicle to travel and view whatever we like, whenever we like. Now, this is . . . The term “technical remote viewing”, all of this is pretty new to our lexicon, but it's something that we've been doing ever since we've been on this planet. We've had the ability to go into a deeper state of consciousness and remotely view and remotely influence other people and places.

Now, this is something that the military started looking into after they found out the Russians were having some success with it. In the public sector, people have been training in remote viewing to do exactly what you've mentioned, which is find lost children, lost items. So this is something that every person can use and train yourself in.

David: So it doesn't require any special gifts or special abilities?

Corey: No. They've proven that they can take just about anyone that's willing to learn it and has an interest and teach it to them. And they can be successful.

David: So we have remote viewing as this category where people are obtaining information. And then we have other categories of channeling, where these elaborate UFO religions get started, and they don't have any reference point to anything else except their own internal cohesion. Then you see people that buy into that channeling, and they say, these beings are doing this in such and such place. This is absolutely the truth, but they have no validation outside of that.

So what's the difference between what you're talking about as remote viewing and maybe some of these channeled teachings that some people think are credible, but then they don't line up with anything else.

Corey: Well, remote viewing . . . When you get a target, they give you the information in the form of letters or numbers, something that's . . . that you're not going to associate with a person, place or thing.

David: The so-called “coordinates”?

Corey: Right. Coordinates. They're going to try their best not to front-load you with what the target is. So they'll go out of their way . . . The person that wrote the target on the piece of paper, a lot of times won't even know what the target is. They'll hand it to a person who will hand it to a person that will bring it to the remote viewer to prevent any psychic leakage or bleed-through.

With the remote viewing, you view the target, but it isn't considered a hit until it's been verified. So in channeling, you're opening yourself up and pulling information from an unknown source, and it's never verified. Or maybe bits and pieces will be verified, but it's never fully verified.

David: Do you think there is some essential flaw in the human psyche, where if a channeler gets a few things right, or halfway right, that people just automatically want to believe everything that's said?

Corey: Once a person gets a little bit of validation from a source, a lot of times, they quit validating. So they'll get a little bit of validation, open their minds, and accept everything that is given to them, instead of validating every data point, which is what is done in remote viewing. Everything has to be validated. It's not considered successful until it's been validated.

David: So even the best remote viewers have brought in a lot of garbage data on their path to perfecting that skill.

Corey: Right. There's going to be a certain amount of the data that's coming from your subconscious. So that has to be filtered out. And they're not going to have one person. At a minimum, they have three, so they can triangulate. And they'll have, usually, a group of people do a remote viewing, and then the people that go through the data know how to ferret out the stuff that pops up through the different people's psyches. And they have personality profiles on the people, and they're able to clear out that information.

David: I've noticed myself that I will sometimes hear a song in my mind, and it seems to come in very spontaneously, but then I'll listen to the lyrics of the song, and I'll discover that that song lyric is a message, a spiritual message, about what's going on.

Remote viewing does seem to involve all the different senses, correct? It's not like it's only happening one way.

Corey: Right.

David: So can you talk a little bit about the sensory experiences that happen when it's being done correctly? What is someone experiencing as they do it?

Corey: You won't know what the target is throughout almost the entire process. You'll be getting in all this sensory data, like wind, certain tastes, certain smells, smell of wet concrete, taste of minerals. And maybe you'll get some auditory input. The visual input is stronger in some people than in others. And the visual input is being fed also by this other sensory data. Your mind is putting together something visual out of all of this. So it depends on the individual how accurate of a picture they can put together from all this sensory input that they're getting from viewing a target.

David: So are there any protocols in terms of when you first sit down to do this? Are there things that you could have happening to you that would interrupt your ability to do this well?

Corey: Yes. You have to totally clear your mind. You have to make sure that you don't have any information on the target. If you're front-loaded, every bit of information that you give on the target's going to be corrupt in some way. I mean, that's . . . Preserving the integrity of the target is extremely important in the process. And also, the viewers need to have a clear state of mind while viewing, so that they don't feed in information from other feelings that they're bringing in from their personal lives.

David: In some of the remote viewing instructional books that I've read, it says that you can't be hungry, you can't be overly tired, and you can't need to go to the bathroom before you start. Would you agree with all that?

Corey: Absolutely. Yeah.

David: Why would that be a factor?

Corey: They're distractions. When they would train children in remote viewing, they would put them in deprivation chambers, so there was no other sensory input other than the target, the information coming in from the target. And as they got more proficient, they could sit at a table in a room with activity going on and be able to focus in on the target.

David: So the so-called average person obviously is not average. That's one of the things we're hearing here. We all have this ability. What kind of things could an "average person", quote unquote, be able to do if they were properly trained in this discipline? How far does this go?

Corey: It depends on the individual. And there's also remote influencing. They can train people to actually have an effect over great distances at a location. So you can influence people to behave a certain way. And there's also technological enhanced remote viewing and remote influencing that is used as a weapon system, that can be used to kill people.

David: Technological how?

Corey: Well, the systems I saw, there were basically two plates. It was like an anode and cathode that hooked up to a black box system, that then was hooked up to, basically, an antenna array. When the person was remote viewing or going into this deep theta state that these people in the Space Program were able to achieve, like a conscious theta state, it would enhance and boost their abilities and focus them through this technology.

Some of these people, they can make a persons' heart stop beating, make them have an aneurysm. They can do all kinds of things remotely.

David: And that's with the technology.

Corey: Right. Well, some of them that have used the technology so much are – they've become enhanced. They use these weapon systems a lot, and they can kill people and harm people without the technology.

David: So let's just talk back now about the “average person”, quote unquote, doing this technique. If you get somebody who becomes really good at this, are they limited to seeing something in the present, or does this also involve the ability to look through time to see timelines, probable futures.

Corey: Probable futures, looking in the past. Yes, all of these are things that are possible with remote viewing. Looking into the future is very difficult, because free will comes in, and there's always things that change the future a little bit. So that's why they call it probable future.

David: When you're talking about the fact that people shouldn't know anything about the target, are there other protocols in place to prevent the mind from engaging with the information and trying to understand what it's seeing?

Corey: Yeah, that comes with practice. We were talking about the weapons systems that . . . I forgot to mention that they also used these to guard facilities, aircraft, spacecraft. They will shield them from

being remote-viewed.

So remote viewers, if they try to . . . If you were trying to view a certain facility, they have people that are basically on etheric guard. And if someone comes in and tries to remote view, then . . . remote viewers call them “those who scatter”. Right when they start to lock in on the target, they find their thoughts . . . it just gets scattered. And they use technology to enhance them when they're doing this.

When I was a kid, they would find out each of us – what our gift or ability was and try to teach us to use that to protect ourself from people remote viewing us. And the method that they taught me was visualizing a counter-rotating blue ball around me, one spinning this way [clockwise], one spinning that way [counterclockwise], and picture it spinning faster and faster in each direction, and picture who or whatever's remote viewing you or trying to remote influence you being pulled into it. And then grab each end and pull it tight to where it snaps.

And it shoots energy back through the person who is remote viewing you, and it gives them what they call an “etheric headache”. And it can give them a very severe headache and other problems for several days.

David: The whistleblower who we're calling Daniel, that gave me the information about Montauk, among other things, because he claims to have worked there, said that at one point, he was recruited for this psychic program. He had somebody come up to him on the base and say, “Hey, what do you think about ESP?” Just seemingly casual. But then they say, “Hey, if you're interested,” they say, “Hey, we could bring you into this class, and you get paid for it as part of your military service.”

And then he also said there were Nazi recruiters, too. They . . . “Hey, what do you think about those Jews.” You know, that kind of stuff.

Corey: The Nazis were experimenting with remote viewing way before the Russians were. That's were they got the idea from is after Operation Paperclip, the Russian version.

David: Are you familiar with this recruitment technique, where somebody will walk up to you and just start a seemingly random conversation, but there's an agenda behind it?

Corey: Oh, yeah. It's happened to me many times. Once you know that tactic, it's pretty obvious. They come in . . . It's coming in and testing the waters. It's sticking their toe in to see if the water's good, to see if they can go in more.

David: All right. So let's talk about the next thing that happened to Daniel. He gets brought into this room with this guy they call the Professor. The Professor has a bald head, white on the sides and the glasses. The Professor is reading off a piece of paper. He's looking at him. He's asking him these questions.

And as the questions are being asked, these seemingly boring psychological evaluation questions, Daniel is getting this absolutely terrible psychic attack from this Professor. This pain in his mind, it's like a screaming, like fingernails on chalkboard, grinding metal. And he told me that if you don't go "What the hell are you doing" to this guy, that you fail the test.

Corey: Yeah, right.

David: Have you ever heard of anything like that?

Corey: I've experienced something like that.

David: Really?

Corey: Yeah.

David: So what happened to you? A similar story?

Corey: Yes.

David: Let's hear about that.

Corey: And it happened many, many times. Yeah, you have to be able to identify not only one other person in the room, but there will be multiple people in the room, and there will be a group that's interviewing you about a certain training you went through. And you will receive that same kind of splinter in your brain kind of pain, and you'll know that you're being etherically attacked. And you have to identify who it is.

And that's not easy when you've got a room of three, four, six people, all of whom are heavily trained in how to do this.

David: In this case, he said that if you don't have that reaction, that you fail, and you're not brought into the psychic training program at all.

Corey: Yeah. Well, at this point, you're already in it, but, you know.

David: Right, right, right. Now, another thing that we've heard from other whistleblowers is that, unfortunately, since a lot of this stuff becomes black magic and occult, that people will make deals with certain demons or certain entities that attach into their system that will defend them against attacks from other remote viewers as they're doing this work. Are you familiar with anything like that?

Corey: Yes, yes. Definitely, some of these darker practitioners will use what they call black magic to invite or use entity attachments to protect themselves just as these entity attachments can be used for all kinds of things. But that can definitely be one of the uses.

David: So let's talk a little bit more about the remote influencing. We're saying now that people can be influenced to have certain thoughts.

Corey: To have certain thoughts that lead to certain actions. To . . . Say there's a Senator that you really want to affect their ability to govern, or they're working on a bill that you really don't want them to work on. First, they'll do a psychological profile, find out their proclivities, what they're interested in, and begin to remotely influence them and get them to act upon things that they wouldn't normally act upon.

A lot of people . . . You have thoughts or fantasies that enter your mind momentarily, but you would never act upon. But this breaks them down a little bit to where they are more likely to act upon it. And the more that they are influenced, the more likely they are . . . The more people that are working them, the more likely they are to make that mistake and then have a big scandal that ends up in the news, and they get distracted from the bill that they were working on.

David: So when you read T. Lobsang Rampa, "Masters and Teachings of the Far East", can you talk about . . .

Corey: I can't even say it, but . . . Ha, ha, ha, ha.

David: They're talking about these Tibetans, and that some of these Tibetan guys were doing black magic. And in the "Masters of the Far East" book, it describes some of these . . . It was a very dangerous practice, but a method of assassination where they would charge a dagger with the energy so that somebody . . . They placed the dagger near where somebody normally is, and that person would become irresistibly compelled to pick up the dagger and actually kill themselves with it.

But, apparently, if you do this, it's extremely dangerous, because you could end up taking the dagger and killing yourself with it. So have you heard of anything that extreme, like charging of objects with magical intention?

Corey: I've heard of people basically using their consciousness on inanimate objects, but not charging an object to where if a person touches it, it causes them to act.

David: Well, let's talk about the voodoo stuff for a moment because that would appear to be a type of remote influencing.

Corey: Yeah.

David: The basic thing you're describing is the same. Somebody creates a doll that's like an effigy of you, and then they maybe stick pins in it, and then apparently some of that is the fear of seeing the doll.

Corey: Yeah. And one of the keys is your target seeing the doll.

David: Right.

Corey: Because when they see it, something . . . a psychological thing happens that also co-creates the experience for the practitioner. So much of what is occurring is being actually created or co-created by the target.

David: So would you say that there is an entity attachment to the doll? That there's some kind of spiritual presence that's put into the doll that can be invited into someone when they look at it?

Corey: That can be part of it, but there doesn't have to be an entity involved at all. It can be . . . If this person grew up in this culture and has a strong belief that there's power in this object, this doll, that now has needles in it, and they receive this effigy of themselves with needles in a certain part, their mind will create these problems in their body.

David: Right.

Corey: So they create . . . They manifest the magic that the person's trying to create.

David: Sure. What do you think about the use of scopolamine in this voodoo tradition? Is there . . . First of all, let's just briefly recap the use of scopolamine in these voodoo cultures. What do you know about scopolamine? What does it do?

Corey: Scopolamine is very nasty. It's a . . . I believe it's a seed that grows on a plant, and I can't remember the name of the plant.

David: Datura.

Corey: Datura. And I believe they crush it up and use the flesh on the inside and dry it out and use it as a powder.

David: Yeah.

Corey: But it basically takes away free will. A lot of the times, it's used to rob people. They'll give the person a drug at a bar - a lot in South America – and the people will . . . Once the drug kicks in, the person that administered the drug will say, “Take me to your house and give me all of your possessions.”

And they'll happily put them in their car, drive them to their house, help them load all the possessions into a truck. And the person will leave, and the drug will wear off, and the people will be bewildered at what happened.

David: But let's get into this. Can you give someone scopolamine and then give them a voodoo curse that they don't remember consciously but is somehow loaded into their mind?

Corey: Most of what's happening is on a subconscious level. So the information could be loaded into the subconscious, and consciously, they have no idea what's going on.

David: So that could be used to enhance the effects. Like they could be given post-hypnotic suggestions under scopolamine, so then when they see the doll, they have this suggestion that's already leaning them in a certain direction.

Corey: Yes. Right. In the programs, they used a synthetic form of scopolamine and a cocktail of other drugs when they were doing chemical blank slating.

David: And could they use that to plant hypnotic suggestions as well?

Corey: Yes. During the blank slating, you're losing memory of incidents. They're also implanting hypnotic suggestions in case you start to remember. So it's like a back door protection.

David: When I was in high school, there was – I think it was on Fox, when Fox first came out, that channel – there was a show called “Friday the 13 th”, and it wasn't based on the Jason movies at all. Every week, the show was about this older man and his attractive female assistant who worked in an antiques shop. And it wasn't really antiques.

What was happening was they kept getting these objects, these weird, old objects that were charged with some kind of spirit or entity or something like that. So every week it was that the object was causing murders to happen, and they had to track down the entity. It seems like if somebody's going to do a whole show based on that, and we know there's a lot of leakage going on, that this idea of objects being able to remote influence people is not just a theory.

So can there be objects that have a charge on them somehow that caused remote influencing – like antique objects, or maybe even from ancient civilizations, things like that?

Corey: Yeah. I mean, objects can hold on to the energy of their environment. And if they're charged with a certain type of energy, they can hold that until they're neutralized or charged with a different energy. So they will hold that energy and emanate that energy until they're neutralized.

David: So we've been talking about remote influencing and some of the ways in which ancient traditions have done it and how it's been incorporated and modernized in these secret programs that we're discussing.

So let's switch back now to remote viewing, so we can exit this episode on something more positive. What are some of the examples, some of the most dramatic, eye-popping examples that you personally saw of remote viewing being a success?

Corey: I wouldn't say this is super positive, but I would read reports of facilities or bases of non-terrestrials that we were planning on attacking or doing infil/exfiltrations of that we had not seen or had no intelligence on. They would have several remote viewers view the location and get a physical layout of what the place looked like, and the operators would use that to build a duplicate and practice their attack.

David: Wow!

Corey: And then it would be almost exactly like the layout that they were given when they would actually arrive on the scene. And it was critical to their success.

David: What was the most stunning personal example of remote viewing that you yourself have done?

Corey: Hm. One I have up on my website might have been in 1989. I was tasked with doing a remote viewing, and it ended up being the Nemesis Star, I believe, is what the target was. And I found myself . . . When I realized that it was a star, I realized that I was outside of our solar system, looking back at our solar system, and our solar system looked sort of like a crescent moon kind of comet, almost.

And I could feel the interstellar winds hitting me. I felt like a piece of taffy being pulled all around. And I was able to . . . It was just . . . It was one of the most vivid experiences I had. And I described it in quite a bit of detail.

David: You also went into something about this idea of a solar flash that came to you in a remote viewing.

Corey: Yes.

David: And I think it would be good to hear that story in context of everything we've been discussing.

Corey: Yes. And it's been a while, so I don't remember all the details. But, yes, it was a remote viewing of . . . and there were beings in the sky, and they would point down. And each time they would point down, something was occurring that I was remote viewing on the Earth. And towards the end of the viewing, there were . . . from the sun came a flash, flash-flash, flash, flash, flash.

And after that, it was . . . in the remote viewing, all the people of the Earth came together and started

holding hands and singing and were very happy. And I saw all these negative people looking like they were just falling backwards, but disappearing – like they were just falling off the Earth and disappearing.

David: Now, you had no idea what you were going to be looking at when that happened.

Corey: No.

David: Did this corroborate with other remote viewing data that they had?

Corey: I was not privy. Usually, you give the information, and that's it. You don't receive feedback, which can be very frustrating, because you want to have validation so you can build your confidence.

David: Right.

Corey: But once you get to a certain point, to where you're proficient, you don't get that constant validation. You're just doing the job, and they'll give you a target. You task the target. They take the information, and then you move on to the next target.

David: But you heard about this flash from others in different contexts, not maybe . . .

Corey: Right. I had heard about certain people remote viewing . . . Some people would view, and they would see the Earth being destroyed by fire. Some people would view . . . Different people were seeing different things. I do know that, but I don't know all the details. But I think they were trying to figure out when and what was going to happen with the sun.

David: But yours sounds almost like a Christian rapture connotation.

Corey: Right.

David: Ascension.

Corey: Right. And they knew my background and all of that. So they approached that information with, “Okay, here's his profile. This is how he was raised. This is his belief system. So that's going to affect the data this way.” And they're going to try to pull out the raw data that they're looking for that causes their flags to pop.

David: But do you think that different people could be on different timelines, where they're going to experience that event differently once it happens?

Corey: Yes, but that's speculation until the moment occurs.

David: Right, of course. All right. Well, you heard it here. We're remote viewing our way through another great episode. This is "[Cosmic Disclosure](#)". I'm your host, [David Wilcock](#). We'll see you next time.

[Cosmic Disclosure: Blue Avians & Spheres in Ancient Art](#)

Season 5, Episode 3

David Wilcock: All right, welcome to "[Cosmic Disclosure](#)". I'm your host, [David Wilcock](#). I'm here with **Corey Goode**. And we have a special edition for you here with the legendary **William** Henry.

Now, I've been familiar with **William** Henry's work since the late 1990s. He has been extremely consistent. I've gone all over the place. I've talked about everything you can imagine – Illuminati, UFOs. **William** has always been focused on ascension, focused on Christ, focused on the true core of what the message is that we're all ultimately here to convey.

And **William** has really done an incredible amount of work, unlike anybody I've ever seen, in terms of looking at art and seeing some really, really provocative stuff. And when we found out the information that **William** had and the corroborating power that that brings to **Corey Goode's** testimony, we said, "That's it. We've got to have him on the show."

Wait 'til you see the stuff that we have in this episode. It is going to blow your mind.

So, **William**, how you doing, buddy?

William Henry: Very good.

David: Can you just give us a little take on your idea of ascension? What is ascension?

William: Well, I always take people back to the story of the caterpillar and the butterfly. The idea is that we're all living in a pupal phase in our human body, but within us is an ascended phase, a next-

level, the butterfly.

And the problem is we're kind of like that cartoon I saw once of the two caterpillars looking at the butterfly, and another one flies by and they say, "You'll never get me up in one of those things." Right? We don't have a concept of what it means to ascend.

But simply, it means to become a celestial traveler, a cosmic being – to leave behind our caterpillar phase and morph, or phase, into an ascended form. And as you said, I've really studied the art of ascension. And they almost always show it the same way.

It's a humanoid form, a light being, a luminous, radiant being, often shown in a sphere – a sphere of light. And that sphere indicates a portal. It indicates an ascension vehicle of some kind that ultimately manifests from within our own body.

David: Now, do you think **Corey's** crazy? I mean, what's your opinion on all this stuff?

William: I hear his story, and immediately I am getting resonance with what I know from the ancient world. It doesn't sound crazy at all to me, because I know Blue Sphere beings exist. I know Blue Avian beings exist in the ancient record. Whether they are actual beings or mythological beings, we can't answer for sure, but, however, humanity has been – I could use the word “obsessed” - with angelic beings for many thousands of years.

And very often in this ancient art, they are portrayed as blue beings, and often feathered or avian-type beings. They are Blue Avians.

David: Now, some people have accused **Corey** of just coming up with this elaborate story that has no precedent. So what I'm hearing you say is that there is a historical precedent for this.

William: Exactly. And when I first heard about **Corey's** story, that's exactly what I got, is like, wow, there's resonance here. This is not something that you're pulling out of your imagination. This is something that has been in the human imagination for a very long time.

David: What is the relationship, in your knowing, between these Blue Avian type beings that you see in the art and ascension?

William: The Blue Avians are teachers. They are the bringers, the light bringers, if you will, of the mystery teachings of ascension. And when we look to these beings, we're looking to them as benefactors of humanity. You could go 'savior', but that's a whole other category of beings. But benefactors – they're wisdom-bringers.

They're trying to get us to wake up to our soul's potential of what is really within us, and our ability to leave the Earth, if we choose, and travel the cosmos.

Corey Goode: And you said you've been researching this specific topic since 2002, correct?

William: That's correct. I started coming . . . Through my study of mystic Christianity, I started researching the ascension stories of Jesus. In the Bible, it clearly says that Jesus ascends in a cloud, and that furthermore, when he returns, he will return that same way – in a cloud.

But when you go over to Christian art, yeah, you will see a cloud. You will see him standing on a cloud, like the Buddhist cloud-riders, for example, but more often than not, there's a precedence for his ascension taking place in a blue sphere, where he is even portrayed as a blue being. And then he is ascending into the stars through this blue sphere, or returning to Earth in this blue sphere.

It's clearly some kind of a transportation vehicle.

David: Well, let's dive out of the plane and parachute into this, because you have such amazing data. I don't want to rob any time from it.

William: Great.

David: What have we got to look at first here?

William: Okay. Let's go back to the Temple of Horus in Egypt. It's in Upper Egypt. It's on the Nile.



300 B.C. And this is what we're looking at here. We see the exterior walls of the Temple of Horus.



And etched on the wall are these amazing depictions of Horus as a bird being. Now, the key thing is that very little color remains at this temple.



But when you zoom in on it, as I have here, you see that Horus is clearly a blue being.

David: There's definitely some blue below the chin and above the eye.

William: Exactly.

David: Right.

William: And you can say, “Well, okay, somebody added that later or whatever. There's really not a history of Horus being a blue bird being, a Blue Avian.”

So let's go over to the Temple of Hathor at Dendera, which is nearby, also built at the same time. And what we see in the Temple of Hathor . . .



David: Oh, man.



William: . . . is this incredible depiction of Horus enthroned with a feather cloak indicating he is a bird

being. The bird symbolism is very apparent here. And he's on his ascension throne, which means this is a throne that he can travel into the stars.

He's clearly a blue bird being, a Blue Avian in our context.

David: Now, **Corey**, what we see carved here does not look exactly like what you saw.

Corey: Correct.

David: But **William**, are these people . . . These are not eyewitnesses that carved this? This is like based on a legend, do you think?

William: These are . . . Well, it could be both. We never know where the artist got the inspiration.

David: Right. Okay.

William: Did this artist at Dendera see a blue Horus, or was he told what to carve by some elder being? There is precedence in the text for the description of these beings in this way, but it's open to interpretation about exactly the source of it.

David: But the core is, we have a human body with a bird face that's blue.

William: Yes. Exactly.

David: Which is insane. This is crazy.

William: Totally. And when you look at Horus here, as I said, he's on his ascension throne. And you have a human figure that's offering a symbol for the soul, as well as a gateway to him. Horus has several very important tools, or implements, in his hand.

In his right hand, he holds his very long stick that's a resurrection stick. It's used for opening the gates of heaven. And in his left hand, he holds the 'key of life'.

Now, **Corey**, take a look at that resurrection stick and look at the bottom of that. What do you see?

Corey: It looks like a tuning fork or some sort of resonance device.

William: Right. It looks like some kind of tuning fork or something. Same with the 'key of life'. These could be puns, but it could also be that this is some sort of a vibrational technology that he's demonstrating here.

Corey: Looks like a very subtle hint at something.

William: Exactly.

David: And we also know from some of the “Wisdom Teachings” episodes I did that the bennu bird on the top of the staff is actually the head of a pteranodon. And it appears that occasionally, these dinosaurs go through portals, and they portal into our time, and that the Egyptians saw that and they enshrined that on this stick.

So it does seem to represent ascension, portals, all that stuff, because of this pteranodon head on the stick.

William: Right. Very peculiar that they would have that kind of design, and we can match it up to our eyes with what appears to be some kind of a dinosaur that shouldn't have been in this scene.

And so here we are looking at a benefactor, a teacher of humanity, who is saying, I'm bringing you the 'key of life'. And I'm also offering you a teaching, maybe a vibration, that opens up some kind of a transportation vehicle for celestial transportation.

Corey: And the Blue Avians . . . Their message has been about raising your vibration.

William: Okay, there you go. So it's about vibration. The vibration, of course, is love, what they most want us to know about.

Corey: Uh-huh. Love and forgiveness.

William: That's what opens the gateways.

David: Are there any other points of continuity, **William**, that we're going to see between this design and some of the other ones in terms of what he's sitting on or what he's wearing? Anything like that?

William: Pay close attention to what's in their hand.

David: Okay.

William: There's very often going to be a stick. And pay attention to the throne that they're sitting on.

David: Can you back up so we can look at that again briefly?

William: Yeah, take a look at that.

David: Okay, what have we got here?

William: You've got Horus wearing a feathered garment, indicating flight or ascension.

David: Or actual feathers.

William: Right, or actual feathers. And he's on a throne. Other examples of this throne will actually feature feathers on them. Osiris sits on a feathered throne, because the idea is that it flies. This is how he comes and goes. And rather than showing a big spaceship or something like that, they're going to show us a simple throne. The technical term for it in mystic circles is the Merkabah throne chariot. This is the throne these beings sit on, and they ascend on this throne. They come and go on this throne.

Corey: That's fascinating.



William: Look at this example. This is extraordinary. We've got a pharaoh on his throne, holding our key tools, or implements – the stick, the key – and he's on a boat, a ship.

It's called the Ship of Eternity, the Ark of the Millions of Years, is the term they used for it. The Ark of the Millions of Years. I mean, what does that say?

Corey: It says a lot.

William: Yeah. These are eternal beings.

Corey: Right.

David: And it looks like the guy on the left is a lot larger than the person on the right. And one of the things, **Corey**, with the Blue Avians, right, they're taller than us.

Corey: Right.

David: So that could be a connection.

Corey: Yeah, it could be. Yeah.

William: Yeah. So we're in a blue sphere here.

Corey: Obviously.

William: We have a blue being and a blue sphere. This is a Blue Sphere being, okay? Putting it together.

David: It is crazy. I mean, you look at that – this gorgeous lapis lazuli stone.

William: Yes, and gold.

David: Yeah.

William: And along the top . . . Notice the line of stars along the top. That's the Egyptian hieroglyph for heaven. So this is saying this is a heavenly being sailing his Ark of the Millions of Years on his throne in his blue sphere.

David: Right. The board would be like a vessel, right? Something that could actually . . .

William: It's a wormhole. It actually looks like a wormhole.

Corey: Yeah.

William: The lotus buds on each end look like the mouths of a wormhole.

David: Right, exactly.

William: So this is a wormhole that this guy is traveling through. He's a happy camper. This is the goal of all human ascension quests. You want to get on that seat.

David: And, **Corey**, you're actually traveling in these blue spheres . . .

Corey: Correct.

David: . . . when you go out there, right?

Corey: Right. Yes. They will appear in a room, zigzag around, stop about this far away from me, wait for me to indicate that I'm ready, and then they expand and I'm inside.

William: There you go. We're going to talk about that as we go because that is THE key experience that all of us actually are capable of having.



Corey: Oh, yeah.

William: We can get a hold of one of these flashes of blue light and open it up into a blue sphere and enter into it and travel.

But let's go forward here 300 years now. Let's leave Egypt, and now let's look at what we have here on the left.

David: That's crazy. There's wings. There's something that looks like a blue sphere. There's all kinds of radiants around it like layers of a portal or something.

William: Yep. This is the Last Judgment scene.

David: Where does this come from?

William: This means it's the Second Coming. So Christ is returning. He ascended on the cloud, and the Book of Acts says he will return the same way he left – on this cloud. It's blue.

This is Fra Angelico's painting, Renaissance. You have Jesus sitting on his ascension throne surrounded by this mandorla, or almond-shaped, gate of light, that is surrounded by blue angelic beings. Blue birds.

David: Is there any . . . Was Fra Angelico in a mystery school or something? Was there any type of . . .

William: Yes. He was one of the benefactors of the de Medici family. They had spent the equivalent of \$50 million in contemporary dollars seeking the secrets of ascension.

David: Oh, really?

William: Called the Corpus Hermeticum. They decoded this, and then they went to Sandro Botticelli, Michelangelo, Fra Angelico, and they said, “Okay, here's the key codes of ascension. We're going to have you hide these in your art.” And that's what they did.

Corey: You know, that indicates to me that these mystery school initiates must know about Blue Avians.

William: They have to. They absolutely have to. Any mystery school initiate, as we're doing here – and we're just looking at the first layer of this image – would be able to say, “Okay. That almond-shaped gateway? That's a portal. It's held open by Blue Avian beings. They've been coming and going to the

Earth plane for many thousands of years.”

And now we have Christ as the new Horus, as he's referred to, connected with the Blue Avians, and celestial travel. He's coming and going from the cosmos in this portal or gateway, surrounded by these blue beings. And it tells me that he is part of that same mystery school. That's what we're looking at here.

Corey: Yeah. I think many of us may have seen these images, but never would have made this connection without the research.

William: Yeah. Your ordinary Christian or other person's going to look at this and say, “Oh, there's blue angels around him” - if they get that far. They might not even see him because that's how they hide it in plain sight. You don't at first see that he's surrounded in a gateway composed of these beings.

David: I want to just throw in something really quick so that some of the conspiracy theory people can put the gun down, because what we hear about from the Edgar Cayce readings and from “The Law of One” is that the original Egyptian mystery school teachings were extremely positive. Isis, Osiris, Horus, were positive beings teaching the same teachings as Christ. The Cayce readings say that. “The Law of One” says that.

And then they were co-opted by the negative later on and distorted. So actually, the Cayce readings to say that Thoth Hermes Trismegistus is a prior incarnation of Christ.

William: Yes.

David: And Thoth is one of these Blue Avians, right?

William: Well, you will definitely see him as a bird being with an ibis head.

David: Right.

William: I don't know that I have an image of him blue . . .

David: Right.

William: . . . but he won't necessarily have to be blue to be connected with this bird tribe.

David: Avian human. Yeah.

William: Exactly. Exactly. So the first time I went to Egypt, I'll never forget the guide saying, "Christianity is the Egyptian religion." I'm like, what are you talking about? You all are Muslims. You're Arabs.

Corey: Yeah.

William: You're Muslims. And then about the third time I heard it, I got it. Christianity is the Egyptian religion updated with now Christ as the new Horus. And the mystery teaching is all in the mystic side of Christianity, the gnostic side – which came out of Egypt. I mean, Christianity came out of Egypt.

The one thing the Catholic Church has done is try to sever that connection with Egypt, because once you follow Jesus into Egypt, now all of a sudden you're confronted with this type of thing and all these mystic ideas. And they don't want you going there.

Corey: Too many questions come up.

William: Yeah, "don't go there."



David: Well, **William**, I'm also remembering sitting in at a lecture that Graham Hancock gave in which

he was describing Egyptian spiritual teaching. And in the Egyptian spiritual teaching you have a heart and a feather on a scale . . .

William: Yes.

David: . . . and it says your heart has to weigh less than the feather to be ascended.

William: Right. Absolutely. So let's just go back one moment and look at Maat, who is beaming Reiki energy, or healing energy, to the pharaoh on the throne.

And she's got a feather on top of our head. That's that same feather.

David: Oh, wow.

William: And this indicates that this being has passed the Earth test. His heart is lighter than the feather. He's a pure being. And that's the only way he gets to sit on that throne, is he's got a pure heart.

David: Amazing.

William: He's a being of light and love.

David: So when we get back to this Renaissance art now, are you suggesting that the mystery school tradition from the Medicis, that they might have some secret documents that they didn't allow people to see that have images like this in them?

William: Definitely. There's no question about it, because what they knew - what they determined from their study of the Corpus Hermeticum, which they got from Egypt and believed as the original mystic Christian teaching – is the power of the image.

The Corpus Hermeticum has a very important phrase, “the image will show you the way”. So they were very, very intent on encoding images with this power that will trigger memories, trigger connections that you can make. You start connecting the dots.

You know, when I was a kid, “Highlights” magazines, right?

David: Yeah.

William: I'd sit on the floor, and there's that one page, "find the 15 items that are hidden in this page". And there is a list.

Corey: Like "Where's Waldo".

William: You could spend hours. I did, anyway. Well now, that's all I do as an adult. I look at art and find the 15 hidden things in the art. But the thing is, the list isn't there. The de Medicis have the list because they put all the stuff there. And other initiates have the list, but we have to find the list. And that's kind of what we're doing here.

Corey: We have to decrypt it without a key.

William: Exactly. Exactly.

David: I'm kind of hearing you say something similar to the concept of gnosis, where information is alive.



William: Yeah.

David: And if you're exposed to that, it starts to trigger this metamorphosis in you.

William: Totally. Totally. So actually, images like this that we're looking at here of Jesus on his throne of ascension, this is not a static image.

This is actually, to the mystery schools, a portal itself. They want you to enter into this scene. They want you to figure out what you've got to do up here (mind) and in here (heart), in order to take this ride on this blue sphere. It's the whole game of Earth life. This is the ascension sphere. And you know you're ascended when you're in the blue sphere.

Maybe these angelic beings like we're looking at here are surrounding you. It could be Jesus himself who's sitting beside you, who's come back to assist you in your ascension.

Corey: They must have cut me a big break. Ha, ha, ha.

William: Yeah, well it's a vital image and message for us to get today, because we understand now today. We have the concept of stargates and wormholes and interstellar travel. We know there's a whole physics behind this now. And that's what's encoded in these images, this whole interstellar physics that's really a new spirituality. I call it stargate metaphysics.

And that's what we find in Ancient Egypt. That's what we find in Christianity, Buddhism. Islam has it as well.

David: Not to mention so many people having near-death experiences . . .

William: Exactly.

David: . . . seeing beings of light come around them with these spherical auras around them.

William: The tube of light of the near-death experience is a wormhole.

David: Yeah.

William: We can pretty much put that one on the table and say, that is a fact. But there's more to it than that. I mean, we know that that wormhole exists, and we're all capable of ultimately opening a wormhole from within us. And that's the idea in these images.

I mean, look at this. You've got Jesus on this throne. He's in a blue sphere. And the sphere is filled with stars.

David: That throne is not attached to the ground, right? He's levitating there.

William: No, he's levitating. And so I have kind of a Forrest Gump mentality sometimes. When I see a ring of stars or a gate of stars, I go 'stargate'. This is a stargate that he's in. Or let's put it this way - more comfort level for people – what if Jesus is a stargate-traveling time traveler, and that's what the blue sphere is? What if?

David: But I think what you're also saying here is that these paintings you're showing us, they're not just artistic choices that these illustrators are making.

William: Right.

David: They're based on esoteric, secret knowledge.

William: That's right.

David: We're not getting the whole secret.

Corey: There's too many different artists doing the same thing.

William: You know how we know that? The artists are often unknown.

Corey: Oh.

William: The author's like: "It's not about me. It's not my greatness. It's about the message here." So the artists are unknown.

Corey: That's important.

William: Yeah. And what we're trying to decipher is, okay, what is the real message behind it? Because they know most of the people are going to look at this and it's just going to go over their heads, or they're not going to have an interest. But if you really get an interest, now you're going: "Okay, this is the core message."

David: Okay, so **William**, when we're looking at these four angels around Jesus here in this blue sphere, who are they? What do we know about them?

William: They're archangels, and they're the guardians of the throne. Sometimes they're symbolized by the lion, bull, man and eagle, which are the four primary symbols of the evangelists and the four

directions and so forth. But their primary role is to indicate to us that this is happening in the heavenly realms and that this is the power of flight or ascension that's being indicated, an angelic superpower.

David: And I believe the word “angel” in Greek is “aggelos”, which means “messenger”. Right?

William: Messenger, right. Yeah, exactly.

David: So, **Corey**, he's saying 'guardians'. He's saying 'messenger'. What is this conjuring up for you right now?

Corey: And earlier, he said 'teacher'. So it reminds me of many people who are having experiences with blue spheres. They're seeing blue spheres that appear in front of them. And sometimes they consciously remember or recall getting information from the sphere.

William: Right.

Corey: So these spheres are imparting knowledge and information to them. And it's always about them growing and changing on the inside.

William: Right.

Corey: From within.

William: Yeah. I covered this in a episode called “The Blue Sphere and the Soul” in my show “The Awakened Soul”, which is the same . . .

Corey: Have you heard of blue spheres visiting people with messages?

William: Yes. It's so vital. There's an Indian guru named Swami Muktananda.

Corey: Yeah, I've heard the name.

David: Oh, yeah.

William: Yeah. Swami Muktananda says that, okay, the most profound meditation experience you can have, that you can train yourself to do, is to raise your vibration so that you attract one of these Blue Sphere beings or flashes of light, and that it manifests before you and it can open up to the size of a sphere so that a person can come through from the other side . . .

Corey: You're kidding.

William: . . . or you can enter the Blue Sphere and travel through it.

Corey: Is this in one of his books, or . . .”

William: Mm-mm.

Corey: Oh, wow!

William: Yeah.

David: Well, this is really trippy because we're taping in Boulder, Colorado. And I was on a train after I graduated college to come out here to Boulder to try to apply to Naropa Institute. And while I was on the way here, I met two guys who were devotees of Muktananda.

William: Wow!

David: And one of these guys had gotten sick of being in the ashram and didn't want to do it anymore. And he's down at one end of the hall, and Muktananda's at the other. And Muktananda shows up and puts his hand out like this, and this ball of blue light shows up in his hand.

William: Yeah.

David: And Muktananda throws it at him. It hits the guy, and he goes into spasms of ecstasy. He's literally spasming on the ground. This is the guy on the train telling me this personal . . . It just randomly happens, right?

And then Muktananda comes up and says, “So now you will be happy and enjoy being here, huh?” And he's like, “Yes, yes.” And after that, the guy was just sweeping and cleaning and doing all kinds of things.

William: Right.

Corey: That's a quick way to raise your vibration, I guess.

David: Yeah.

William: Exactly. But the message has been here for, we've documented 2,500 years of human history, where these Blue Spheres have been around. It could be that now is our time for perhaps mass numbers of people to begin to develop this ability and to have this experience. It's incredible.

Corey: Yeah.

William: I think it's perfectly natural for cosmic beings to be able to have this experience. Again, we're the caterpillar saying, "You'll never get me up in one of those things."

Corey: This experience is for everyone.

William: Exactly. Exactly.

David: You mentioned "The Awakened Soul". You said that's a show?

William: Here on Gaia.

David: Okay.

William: It's "The Awakened Soul". 13 episodes, lost science of ascension. We start from the very beginning. I try to provide a historical context for the idea of ascension, going back into history and saying, "Hey, we've been talking about this for a very long time. And so let's look at the history of it. Let's look at the art."

Let's stair-step into it so that we can see that a lot of people . . . You hear the new-agey term, 'I'm a starseed'. Right?

Corey: Right.

William: And it turns a lot of people off. But a lot of people don't know that that term was invented by the Stoics in Ancient Greece, 200 B.C., . . .

Corey: Really?

William: . . . where they started discussing our soul as a starseed.

Corey: I would assume that it's more of a new age kind of term.

William: Right. And so that's part of the point of “The Awakened Soul”, is to say, “Hey, guys, this conversation we're having has been going on a very long time. Let's bring some historical documentation into it. Let's put some art with it, and let's show how we all can do this.”

Corey: That's going to be interesting.

William: Yeah. So I'm really excited about it. So thank you for mentioning that.

David: Well, let's see something else. What else have you got in your bag of tricks here?

William: Let's go to the fourth century A.D. This is from Egypt. I took this image from the Coptic Museum in Cairo, Egypt.



The Coptics are the Egyptian Christians, and they believe they have the original Christian story – the original story, which is different from the view most people understand today.

But the key thing is, look, we've got Jesus sitting on a throne holding a book in a blue sphere. This is an ascension scene.

David: Just for the sake of the skeptic, is it possible that all of these guys could have seen each other's artwork? Or are they too geographically isolated?

William: They are geographically isolated. It is possible someone went to Egypt in the fourth century or so forth and saw this, and they duplicated it. But the idea is that this is part of the Christian documentation.

David: Right.

William: This is what they say. This is the experience. And this is corroborated then by other people who've had similar experiences, such as yourself.

Corey: And back then, art was rooted in tradition.

William: Right. And people were going to stick with the tradition, too. They aren't going to veer off and try to come up with their own interpretation of it, because it's sacred.

David: Well, something I'm thinking of too, **William**, is it says in the Bible that Jesus would only speak to the masses in parables.

William: Right.

David: But then to his disciples behind the scenes, which you don't get to read in scripture, he's saying things that are not in parable.

William: Right.

David: Do you think this is part of the undisguised teaching?

William: I think this is part of the secret teaching of Christianity because your average ordinary Christian has probably never seen images like this. And there's a reason for that because this is for the initiates.

Corey: Yeah, I was raised Christian and still consider myself a Christian, and I have not seen most of these images.

William: Right, and because the church hierarchy has said, "Okay, we'll just keep that over here, and then maybe people will discover it on their own."

So looking at this image here, it's really provocative because you've got Jesus in the blue sphere. And notice the concentric rings.

As a symbolist, when I see concentric rings, I'm thinking two things. I'm thinking sound or vibration. Sound rings – whoa, whoa, whoa, whoa, whoa, whoa, whoa, whoa.

Corey: And it goes back to that tuning fork.

William: Exactly. It goes back to the tuning form, the key of life. And I'm also thinking portal, vortex, gateway, wormhole. Okay? And so here we could read this and say, “All right, this is Jesus on his throne in a vibrational gateway, obviously exuding light and love. And he's traveling through the cosmos.

And now we add in this image these counter-rotating rings. Is that torsion field? What are we talking about here?

Corey: And it also could be he's a higher vibrational being, and it could be vibrations emanating from him, as well.

William: Right. See, that's the key point too, because these are super high-vibrational beings that are beyond our normal perception. So they need some manner or vehicle to slow down so that we can perceive them. And perhaps that's part of the function of the blue sphere. It's certainly the function of that throne, because I'm going to give you a real esoteric secret here.

That throne, with his feet on the footstool, that's the Ark of the Covenant. Christianity is supposed to have dispensed with the Ark of the Covenant because that's an Old Testament image. And Jesus doesn't need the Ark of the Covenant.

Corey: Right, the new Covenant.

William: But he's got his feet on the footstool, and the footstool of God is the Ark of the Covenant. It's the Earth and the Ark of the Covenant. So what if the Ark of the Covenant, then, is some kind of a device that slows him down so that we can perceive him? Because otherwise, he's moving too fast and completely out of our range of perception.

Corey: And in the Old Testament, the way it's described it sounds like a device.

William: Absolutely. There's no question. It's some kind of a device.

Corey: Multipurpose device.

William: Exactly. And I go beyond it being an electrical device, some kind of radioactive weapon or whatever, into it's a teleportation machine. So that wipes us too far off for our conversation, but . . .

David: Well, also, the storming of the walls of Jericho, they use the ark and they blow the horns, and then the walls turn into mud. The stone just goes into liquid, and it all falls down.

Corey: They used vibration.

David: Yeah.

William: Yeah, definitely. But here again, we've got the throne and the blue sphere together. This is the Egyptian image from the Blue Avians.

David: And you just triggered something in me. When we're looking at these concentric spheres, so amazing. In April 2001, I made a prayer. And I said, "The only thing that hasn't happened to me yet is I've read about these people seeing blue spheres, and I want that to happen to me."

And then I call my father and he's on the other line with my brother, so we get into a three-way call. And my brother then explains that he had seen a blue sphere in his meditation.

William: Wow!

David: And this thing shows up. It's just hovering in the room, and then it goes up to the ceiling, and it spreads out into a vortex that looks just like that. The way he described it was it was brighter on the edges, and it got bluer towards the middle.

Corey: When he told me this, I was shocked.

David: It turned into a stargate. It looked like a wormhole going up through his ceiling.

William: Right.

David: And then when it faded, it said, "The ascension that your brother is writing about will not happen all at once. It is a series of increasingly uplifting events. This is the first of these events for you."

William: There you go. There you go.

David: Blew me away. And as I'm looking at this . . .

William: It 'blue' you away? Ha, ha.

David: I'm like, this is exactly what my brother saw. Ha, ha.

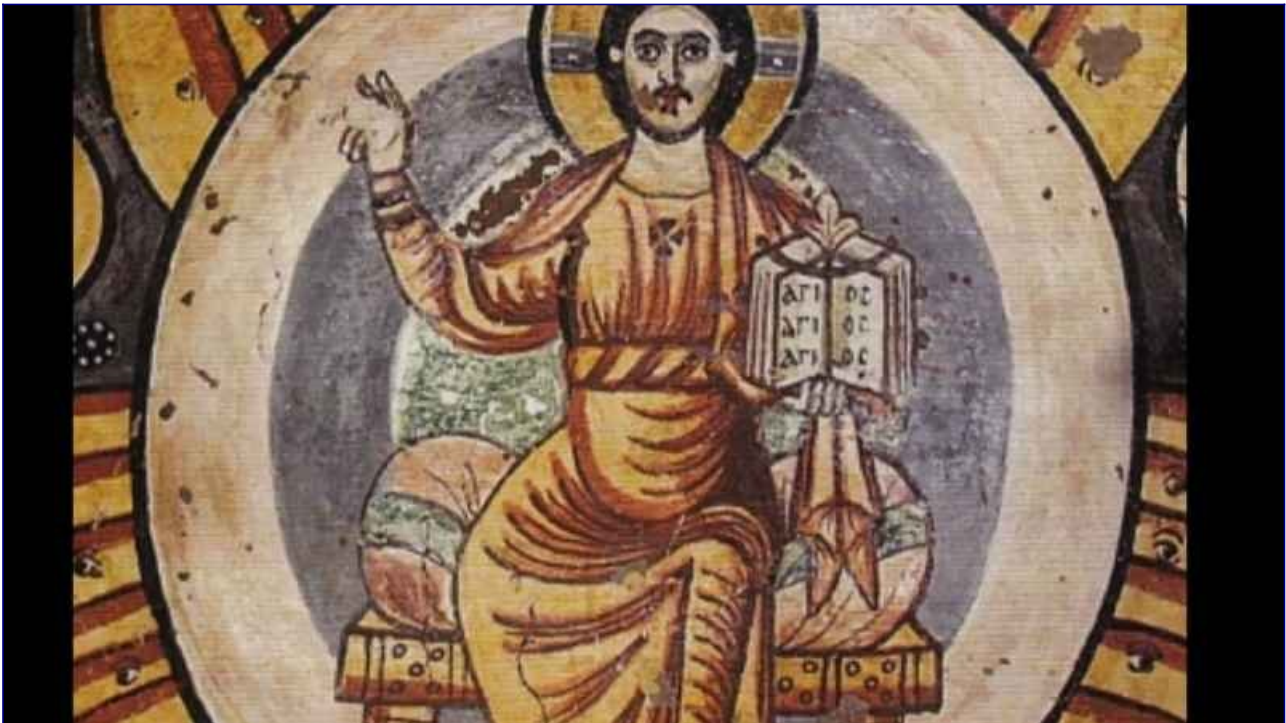

William: Right. So here's the detail here. I mean, where he's got the book, the Book of Knowledge. It's the book about, "Hey, this is how you do it". And he's got the breastplate. He's got the cross right there at the breastplate, which indicates the open heart chakra, right? And he's giving us a blessing here.

So if we are sensitive and attuned, we're really locking onto the symbolism and saying, "Okay, he's inviting us to open the blue sphere within ourselves, or to invite a blue sphere into our awareness so that we can have this experience."

Corey: This is amazing.

William: It's ascension.

David: Well, **Corey**, what's the connection between . . . because we're kind of dancing around this. We haven't quite hit it, though. What is the connection between the message of Christ and the Blue Avians

and the Sphere Beings, and even maybe let's toss in the people from the Inner Earth, the library conversation you had with Kaaree. How does this all thread together?

Corey: Well, their message is all about forgiving others, forgiving yourself, to constantly strive to be of service to others, and to raise your vibration – to focus the light inwardly, you know, to pull the log out of your own eye before you start reaching for the splinter in other people's eyes.

William: Right.

Corey: And that sounds like the tenant of most of the religions.

William: Yeah, absolutely. And what I get out of that message from you is that, hey, this gives us additional motivation to actually do that. Because now you know that, hey, you're not living a life of service just to get a reward. But if you know that this is the reward, it's going to really motivate you, I think.

Corey: Yeah. Let's see some more of these images. These are amazing.

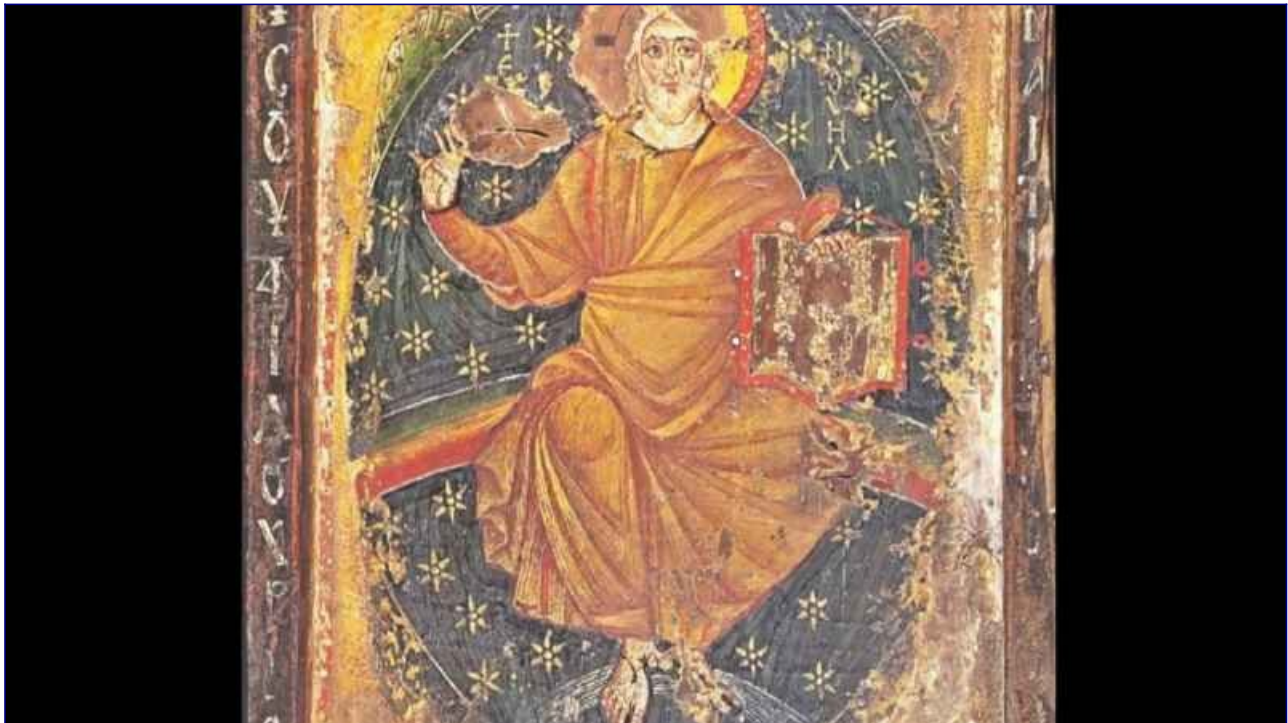

William: Great. Okay. So this is Mount Sinai. We all know the story of Moses and Mount Sinai. There's a beautiful monastery there where they started developing a lot of this early imagery. And here we have the ascended Christ on a rainbow bridge in a blue sphere filled with stars once again.

So this is obviously another portal or gateway indicating that he's traveling through the celestial realms.

Corey: Hm.

David: And you've said in other stuff, and I covered this in “Wisdom Teachings” a little bit, when he's sitting on the rainbow, what does that mean?

William: That indicates that he's in what's called the Rainbow Body of Light. That's the Tibetan term for it. Christians call it the glory body, the Resurrection body.

David: Right.

William: It's the butterfly I referenced earlier – the next level of human evolution. Within us is this light body that is portrayed as radiating rainbow-colored light. And so anytime you see Jesus sitting on a rainbow or enfolded within this rainbow light, that indicates that he is in his glory body, which is a pun on . . . The word 'glory' means 'to glow rays'. So he's glowing rays here. He's in his light body form.

David: Well, it looks like he's standing on a blue sphere.

William: It does. There is that second blue arc beneath him, which again is the footstool idea. But again . . . stargate traveling, possibly time traveling.

Corey: Stars in the background.

David: Can you just tell us again, what's new and hot here on Gaia that you've got to offer?

William: “The Awakened Soul”.

David: Okay.

William: It's 13 episodes of the lost science of ascension, where we're going to take people through this incredible history of ascension, with also practices involved as well, referencing many different traditions – the Christian, the Buddhist, the Egyptian tradition, the Divine Feminine – and how they all view this idea of ascension, and how we can make it a reality for ourselves.

David: That's awesome.

Corey: I'm really glad this was brought to my attention, because, I mean, like I said earlier, many of us have seen some of these images. We never would have put this together.

William: Yeah, well thank you. I mean, it's a powerful story. It's, I think, THE message for our times, so that we can all raise our vibration in this way and perhaps take a ride in one of these blue spheres.

Corey: Thank you.

David: All right. Well, that's all the time we have for this episode. I hope you've enjoyed this as much as we have. I'm [David Wilcock](#). We've got **William Henry** and **Corey Goode** here, and we thank you for watching.

Cosmic Disclosure: Symbiotic Relationships of Ascension

Season 5, Episode 4

David Wilcock: All right. Welcome back to “[Cosmic Disclosure](#)”. I'm your host, [David Wilcock](#).

We've got **Corey Goode** here, the insider's insider. And we have as our special guest mythologist, art historian, **William Henry**.

And the reason why I really like what **William Henry** has done is, first of all, he's been around as long as I have. He's a real veteran in this field. But more importantly, he's talking about ascension from a perspective of bringing in practical data.

There's a lot of people who have been around a long time. They talk about this stuff, but it's, “Oh, I'm channeling this, that, or the other.” There's no real reference point, no way to prove that what they're saying is true.

But **William**, you're bringing in hard data. You've got things we can look at, things that clearly have a history behind them.

William Henry: Yeah.

David: And you were telling us about this painting of Jesus here. Let's get into that again. These stars that we're seeing. Those stars represent what?

William: Well, it represents the cosmos. When we're looking at Jesus in a blue sphere, which is what he's in, filled with stars, I read that stargate from our contemporary perspective.

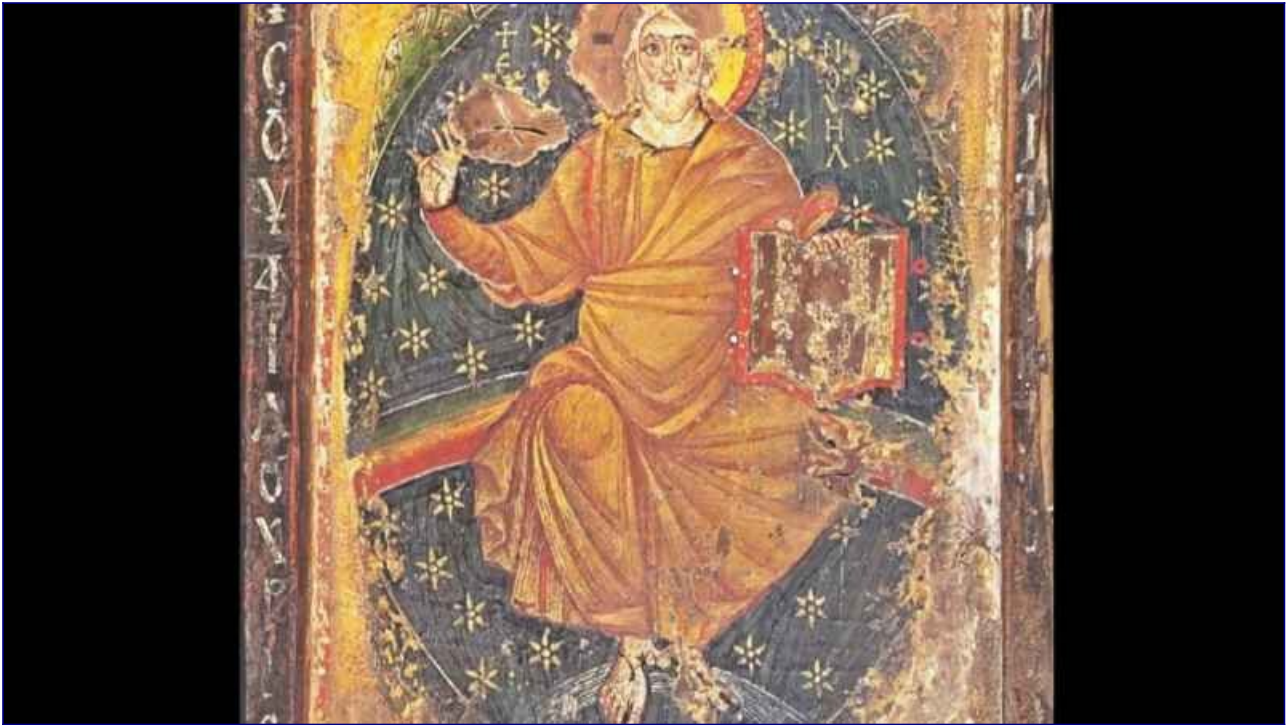

William: And you know, when you research the Dead Sea Scrolls, which were the books of the Essenes, it's remarkable, and even in the Bible too, it's remarkable how many times they reference gateways, portals. So they're clearly . . . and stairways to heaven. So this is not too far out of an idea. It's actually in these texts that they are describing beings coming and going from the celestial realms via stargates.

Corey: With the terms they had . . .

William: With the terms that they had then.

Corey: Right.

William: Right. We can say wormhole today. We can talk about Calabi spheres. We can use scientific terms if we want, but hey, let's just keep it simple, okay, because people now, thanks to movies like “Stargate”, “Contact”, “Interstellar”, we have the physics behind it and now we have the visuals.

We have a consciousness that says, “Okay, we've caught up with these super-advanced beings that travel the cosmos in stargates, wormholes, or blue spheres. This is one way to do it.

David: Now, **Corey**, you've said that you feel that the stargate itself, the blue sphere itself, is alive.

Corey: Yes. Well, the Blue Sphere is one of the five beings in the Sphere Being Alliance. So it is a higher-density being. So it is a higher-density being. It's an actual being.

William: Yeah. Right. I would go along with that.

David: So this is like a symbiosis then between the person in the being and then the being itself as the sphere.

Corey: And both the Inner Earth and the Blue Avians have explained that they are in a symbiotic relationship with humanity and our co-creative consciousness and our mass consciousness.

David: Well, what's so bizarre about this is anybody who's been watching "Wisdom Teachings" knows I did a whole long sequence on Wilhelm Reich and his idea that the precursor for biological life . . . I've always been talking about life is a quantum field effect. Life precipitates out of the quantum vacuum.

Well, Reich actually looked at life that was formed that turns into cells where they hadn't existed. And in it's primordial form, it shows up as a blue sphere in this case on a microscopic level. But it just manifests. And then the blue sphere coalesces the water or the material around itself and forms life where none had existed.

William: Incredible.

Corey: I hadn't heard that.

David: So this is like getting us a throughline now between macro, macro, because you're saying the largest of these blue spheres in the solar system are how big?

Corey: The largest of them contains . . . Our solar system is contained by one of them.

David: Oh, the outer barrier is a sphere.

Corey: Yes.

David: Wow! Okay.

William: Well, think about the she-powers, the Siddhi powers, which are the eight great powers, instant materialization of wishes, invisibility, levitation, and the ability to make yourself as big as you want or as small as you want.

David: Right.

William: I mean, these would be part of the consciousness powers of these beings, right?

Corey: Co-creative manifestation.

William: Yeah.

David: The whole point too in terms of scaling when we're dealing with a holographic universe, in the hologram, in a fractal, no matter how much you zoom in on the fractal, you keep seeing the same pattern.

William: Right. And I love that word “scale” in this context. Jacob scaled the ladder to heaven, so he ascended, right? But scale's a musical term, so he raised his vibration.

Corey: Yes. I was about to go there.

William: Right? Goes up to the heavenly realms, then scales back down.

Corey: Goes up the octaves and down.

William: Right. Right.

David: **William**, what's the teaching . . . because you obviously are a much greater Bible expert than I am and these religious texts in general. Are we looking at a . . . Is the original fall how life is created out of this divine perfection? And do we have to resuscitate from that fall?

William: Yeah. That's the esoteric view of it. The Jewish mystical view was that Adam and Eve were originally light beings. And then when we're evicted from Eden . . . Remember the biblical story, Book of Genesis, Eve eats the apple of wisdom and we're evicted from Eden.

Yahweh, the Old Testament god, does two things. He makes a gate at the east of Eden, which we exit through, places cherubim on either side of the gate. And then the thing most people forget about is he made for humanity coats of skin.

The traditional view is that these are animal skins that are covering the body. The esoteric view is . . .

Corey: Because they were naked.

William: Right. But the esoteric view is the coats of skin are these skins that we wear, our human skin, because originally we were light beings.

Corey: Luminous.

William: Luminous, radiant, perfect beings. That's the term they used. They were perfect.

David: That's in that movie “Noah”, with Russell Crowe.

William: Yes, it is. Yeah, they drop a line on that.

David: The people of Eden are light beings first.

William: Yes, exactly. That's such a key part of this as well, because then Jesus is then the second Adam, whose part of his mission is to show us how to reclaim our original light body form and ascend, right? He's going to show us the way to do this.

Corey: To get out of here.

William: To get out of here. And I've got an image for you, **Corey**. Look at this. Think about this one.



William: This is Ravenna, Italy, 5th century.

Corey: And he's not in a wading pool. Ha, ha.

William: Ha, ha, right. I mean, they call this a cloud. But who's ever seen a cloud that looks like a blue sphere, right?

Corey: Right.

William: I mean, what are we looking at here? The Earth? You could make an argument this is the Earth that he's on. But no. Going back to the Egyptian images we looked at in the last episode, they're indicating that this is a sphere of consciousness in the very least. It's also a transportation vehicle as well.

Corey: A sphere of consciousness is an interesting way to put it.

David: **Corey**, did these beings say that they're just doing this for us here, the Sphere Beings, or are they kind of like a galactic or even intergalactic . . .

Corey: This is occurring in this local star cluster of 50 or so stars, that they are somehow karmically tied to or that there's some sort of not only symbiotic relationship, but there is some sort of attachment that we need to ascend so they can ascend and return to Source, basically.

William: Yeah. I've come across that I my work as well with the Tibetan rainbow body tradition, because the Tibetans teach that this resurrection or ascension teaching, the rainbow body, is taught in 13 star systems, including our own. And you've got beings coming and going from these various star systems, probably through a system of wormholes, right?

David: Oh, wow!

William: So if you think about it, Earth then, maybe we're a colony in a federation - you know, I hate to use the Star Trek term – but a federation of star systems where this teaching is taught.

So the question then is - maybe you can answer this, **Corey** – are we the strongest link in this chain or maybe we're the weakest one? What if it's us that has to lead the way?

Corey: Right. Well, we do have to lead the way. The whole message is that they're not here to save us. They're not savior beings. They're here to give us a message. And we're to take the message and make the changes and save ourselves.

William: Yeah. Incredible. I mean, it's incredible. But to think that we're linked to 13 star systems, that just goes like . . . and you're saying it's 50, it's more than 50?

Corey: Right. The local star cluster is around 50 or so.

David: Well, **William**, I'm just really curious where the references for these 13 star systems . . . Where did you see that?

Corey: That's interesting.

William: Yeah. You know, I was at a conference in California and a couple came up to me, and they told me that they both had PhDs from the Harvard Divinity School. They specialized in the rainbow body teaching . . .

David: Wow!

William: . . . and told me that essentially what this means is that they believe that the body, the human body is designed to be spun into a vortex of energy that dissolves into five-colored rainbow light, leaving behind hair, toe and fingernails, which have no nerves to be transmuted.

And what they said to me is that they worked with the Dalai Lama. They translated Tibetan texts. This is their expertise. And they always wanted to know that - the Tibetans themselves, this is part of their secret teaching - said that once you attain the rainbow body, you can travel to these other 13 star systems.

David: Oh, wow!

William: And they always wanted to know, well, how do they get there? And then they said they were watching one of my presentations on “The Ancient Egyptian Arcs of the Millions of Years” like we looked at, where I identified them as wormholes. And they said they got their answer, that once you attain the rainbow body, your body itself becomes the stargate. It becomes the wormhole and then you can travel to these other star systems.

But let's just think about this just for a moment. If you go into myth and sacred tradition around the world, then you develop a pretty ready list. You're talking Orion, Sirius, Pleiades, Ursa Major. I've just

named five. But the Tibetans are saying there's eight more. And I'm sure there are more than 13. It's got to be up . . .

Corey: Right. And some of these are star systems with many stars in them like the Pleiades.

William: Right. So these are all familiar star systems that we can go out and look into the night sky and point out Sirius or Ursa Major.

David: Alpha Centauri.

William: Right. Exactly. But now the real message here is we're connected to these star systems even while we're in our earthly form. And we can call them in, but I love your message and I agree with it. They need us just like we need them.

Corey: Yeah.

David: So, **William**, where are we looking here? Is this inside a temple or something?

William: Yeah. Actually, this is in Ravenna, Italy, in a church in Ravenna, Italy, San Vitale, actually. And we see Jesus again on the blue sphere.

David: Is that gold leaf?

William: Yes.

David: Yeah. Wow!

William: Yeah, mosaics. And you've got the angels on either side indicating, okay, these are celestial beings that we're dealing with. And they're kind of escorting him or providing a power source for him.

And I really like to use the word 'upgrade' too, because in “The Awakened Soul”, my show here on Gaia, I did an episode about the hero's journey but from the soul's perspective, that the whole purpose of our incarnation here on Earth is to get that upgrade.

David: Do you think Jesus is holding his crown of thorns here? What is in his hand exactly?



William: That is a crown. It's also a ring that he's holding. And when you trace that symbol of the cosmic ring, you'll see that in Zoroastrianism as well.

David: Oh.

William: You'll see it in Sumerian depictions where the god is holding a ring. They call that . . . The title for this is, get this, the Ring of Cosmic Sovereignty. I want one. Ha, ha.

David: Ha, ha, ha.

William: Can't get it at Best Buy right now, but maybe soon, right? The Ring of Cosmic Sovereignty. What that means is he can go, be, see, do anything he wants. He's got the ringer vibration that he's a fully sovereign being, and he's a cosmic being.

Corey: It's almost like a seal.

William: Exactly.

Corey: A kingship or royalty, or some sort of title.

William: Right. Exactly. But here's the key to this art. What they intend for you to see when you're looking at an image like this is, again, not a static piece of art, but an invitation.

They believe that the vibration of the blue sphere and the Ring of Cosmic Sovereignty is transmittable through the art. How can that be? Well, you're dealing with gurus here. You're dealing with super-advanced avatars that can even manifest through a piece of art and transmit that vibration to you.

This is why the church is like, "Okay. You know, if people just need a piece of art to get there, what do they need me for?" We don't need a church. We don't need all the books. We don't need the hierarchy of priests.

All the person needs to do is to open their heart and connect with this mentally, physically, spiritually, and emotionally, and they can begin to raise their own vibrations.

David: What do we got next here?

William: Let's see. Oh, here's an angel on a blue sphere.



William: So here's a celestial being in the cosmos.

David: It looks like he's surrounded by them.

William: Right. Exactly.

Corey: And back then, they did not believe the Earth was a globe, correct?

William: No. Right. Exactly.

David: So this is like a matrix of spheres coming in.

William: Yeah. You can read this almost as an interconnecting or link perhaps of star systems.

Corey: It could be spirals, those . . .

William: Yeah. Right. Absolutely.

Corey: Inside the spheres.

David: But **Corey**, you've also said that we've had a whole bunch of these spheres come into our solar system recently.

Corey: Yeah. Hundreds and thousands.

William: Wow!



David: Ah. There it is.

William: Yeah. There it is right there.

David: Boom!

William: Yeah. So this is a piece of art. This is a transfiguration icon. This is an event in the Bible. Right after Jesus is baptized, he gets these newfound powers. First thing he's going to do is go demonstrate to a few disciples his capabilities. And he takes them up to the top of a mountain and reveals himself as a being of light.

He transfigures, which means he changes his form from flesh and blood into a light body form. And the Bible . . .

David: But he comes out of the tomb . . .

William: This is before that.

David: But people don't recognize him.

William: No, this is before that.

David: Oh, okay.

William: This is early on. This is before the crucifixion and resurrection.

David: Oh, okay.

William: It's very early on. And so he demonstrates, "Hey, guys, here's a preview of what's going to come later on."

David: Okay.

William: I'm going to change my form so you can show that you all have this capability.



David: Right.

William: And in the descriptions, the disciples say, “Okay, this cloud opened up behind him.” And that’s what our traditional view is that this blue sphere behind him filled with radiant light and the light coming off his body is actually a cloud.

Corey: Well, you know, people that have flown through the Bermuda Triangle, they’ve reported seeing blue mists.

William: Mmm. Yeah. Really important bit of imagery here, because I think when the portal opens, some kind of a mist emerges from it. That’s why they think of it as a cloud, because they probably don’t have a conception of a stargate or a wormhole.

David: Sure.

William: Right? And so what also happens here, you see the two figures on either side? That’s Moses and Elijah, who suddenly manifested as if out of thin air.

So they too must be these ascended beings that have the capability of phasing in and out if they choose to. They’re probably in blue spheres themselves. So really important imagery.

And, again, the teaching that goes with this is that this is how they transmitted the vibration of the transfiguration is through this art, these icons. They called them sacred portals or sacred mirrors. That's their term for these icons like this.

Corey: It's so amazing to me that you've been looking into this since 2002.

William: Yeah.

David: Well, you know what I'm thinking of too is the actual physics of this. Dr. John Searl developed the Searl levity disc, where he has these rotating rings and you create antigravity. And that was then replicated by two Russian scientists, Roschin and Godin. They actually got levitation.

And what they noticed is once they set up the antigravity field, that there was these what they called domain walls, these bubbles. And you could actually take a thermostat, a thermometer, and measure very distinct changes in temperature. It would get colder as you get towards the middle in very discrete walls, just like you see here.

It's spheres within spheres, evenly separated from each other.

William: Right.

David: So this is actually a physics.

William: Absolutely.

David: This is like what we're actually . . . These energy fields, there's a scientific precedent for them manifesting that way.

William: I think there's a super-high-energy physics that accompanies images like this. You're absolutely right on it. And it ultimately leads you to the Blue Spheres as a way of being transported through the cosmos. Because, again, this is an invitation to join them, to raise your vibration, to change your form, because as the Bible says, flesh and blood can't inherit the kingdom of heaven.

So it's saying we're going to go in a different form. And the Blue Sphere is the method that is the way you're going to go.

Corey: And that scares some people. They think you shed your skin, you die.

William: Right.

Corey: You know, you've got to go through some sort of painful death process.

William: Right. Right.

Corey: That part, you know, scares people.

William: Yeah, and that's why the message of the service, the love and forgiveness is so important, because this is how we raise our vibration and begin to realize, "Okay, I can safely leave behind this form and enter my next level of evolution." Yeah.

David: Well, let's have another one. Let's see what we got here.



William: Another transfiguration.

David: It's the same thing, yeah.

William: It's the same thing, but look what he's got in his hand again.

Corey: Different artist, same time frame?

William: Same time frame, different artist. But he's got that stick in his hand, just like we saw in the ancient Egyptian image in the previous episode.

David: Right.

William: I call it the Resurrection stick. It's the stick that opens the gates of heaven or hell. So we're talking about either an actual object or technology or a symbol for a level of consciousness that these beings possessed. They can come and go, phase in and out.

Corey: It looks like an antenna, something that would send or receive vibration.

William: Right. Exactly. And so we're talking about scaling and raising our vibration once again. And he's saying, "Okay, here's the tool that you need."

David: Well, and one of the things . . . **Corey**, you probably can back me up on this. One of my insiders is a guy who worked with extraterrestrials and reverse-engineered 13 different UFOs and came up with eight different methods of antigravity.

And one of the things he kept saying to me over and over again, he said, "**David**, you've got to remember this. The more technology you have, the less technology you need."

William: Ah. I love it.

David: You get an all-in-one device. And that's kind of like . . . Like I guess the equivalent for you would be like the smart-glass pads, right?

Corey: Well, not . . . Well, more so the stone tablets that we were finding that we didn't know what were, that ended up being . . .

David: In the Inner Earth.

Corey: Right. . . . that ended up being technology. And non-terrestrials wanted us to trade it for trinkets.

William: Wow!

Corey: And we stopped trading once we figured out it was a technology.

William: Interesting. Wow! Reminds me of the Me tablets of the ancient Sumerian stories. The Anunnaki are trading these Me tablets, the tablets of destiny. They're stones. They're described as stones. Some of them contain the secrets of ascension, secret to civilization.

Corey: So they could be technology too.

David: Yeah. That's probably the same thing, because you said these tablets, the big thing is stasis.

Corey: Well, not exactly the tablets, but the stasis – it's this similar technology.

David: They can alter the flow of time. They can create a time bubble.

Corey: Right.

David: Right.

William: You know, and a tie-in too to that is Moses originally had the blue sapphire stones. He made two trips up Mt. Sinai, remember? The first trip he goes up and he's given all the enlightenment teachings on blue sapphire stones.

David: Ah!

William: He comes down Mt. Sinai, sees the Israelites worshiping the golden calf, and he smashes the blue sapphire stones. And all the initiates are going, “Oh, there they go!”

And then he goes back up Sinai again and he comes back down with the Ten Commandments - the penal code. So those blue sapphire stones are super-important.

And one of the legends is that that staff that Moses used to part the Red Sea was also made of blue sapphire.

David: Ah!

William: And it was so heavy, it took many people to be able to lift this thing. So it may not be physically heavy, but it's just indicating, okay, this is advanced consciousness technology you're dealing with. Humans can't lift this stone. And it's kind of . . .

Corey: We can't wield it.

William: We can't wield it. Exactly.

Corey: We cannot wield the power yet.

William: We can't wield this power yet. And so they took away those blue stones. And I wonder if that's what you're describing, because that sapphire blue description, why are they blue sapphire unless it relates to the Blue Spheres?

David: Well, just on an exoteric level, it's really bizarre that you have these Egyptian paintings where you have Horus or Osiris with this staff, and then the same kind of thing around him. And now you're seeing Jesus portrayed with this.

William: Exactly. It's not . . .

Corey: Same . . .

William: I mean people would look at that and argue that's the cross, but it's not the cross, because the cross he's crucified in or upon would be much larger.

David: Right.

William: So this is something else.

David: And it has the T at the bottom too.

William: Yeah.

David: Yeah.

William: So this is something else that he's carrying that's a symbol for a capability or a level of consciousness or something along those lines. And it's identical to what we saw in Egypt as well.

David: Well, let's have another one here.



William: Let's see what we've got here. Okay, so this is another ascension image, a detail of it where he's wearing this bright white garment indicating he's a light being. He's got the illuminated halo around his head as well. And he's in the blue sphere again, ascending through this sphere.

David: And what's the time frame here?

William: We're still . . . This is 6th century AD.

David: 6th century.

William: Yeah. 6th century, 7th century AD.

David: So by this point in 6th century, you're only dealing with a relatively small number of generations since these events actually took place.

William: Right.

David: So there could be oral traditions. There could be hidden documents that would have been more readily available back then.

William: And there might have been more images as well. I mean, then we enter this age, they call it iconoclasm, where Islam comes along in the 6th century and they declare these images are . . . This is idol worship.

Corey: Heresy.

William: Right. This is heresy. So they destroyed a lot of this. And there's no telling what we've lost in terms off this imagery and other prompts that would really give us more clues about this ascension technology.

Corey: Same thing the Spaniards did when they came to South America.

William: Exactly. Exactly. So what a loss. I mean, a huge loss for us. But I think we're reclaiming it today. We have enough examples to where we can now start to piece it together.

David: Well, I can't help but notice that there's wing-like images in the red there. Is that part of what you're wanting us to see?



William: Oh, yeah. Exactly. So those are going to be those angelic beings that are symbolic of the heavenly power, celestial powers, and power of flight.

David: Like the seraphim, cherubim.

William: Like seraphim. Yeah, exactly. Exactly.

David: Wow!

William: Very cool. This is one that is very provocative. This is Hildegard of Bingen's "Man in Sapphire Blue".



William: And she describes an experience where this man in sapphire blue manifested out of a blue flash, just like we were talking earlier. And she sees him. And now he's here beaming this energy to her. Anytime you see a person in art with their hands open like this, they're beaming energy to you.

Call it reiki, the Holy Spirit, whatever term you want. We are to mirror this image in sacred art. We are to put our hands up and connect.

Corey: And receive.

William: And receive. Exactly. And establish a link, an energetic link, because the idea again is we all want to raise our consciousness so that we can have this experience that you had, right?

David: **Corey**, is it possible that the Blue Avians could change the way they look to look more human to someone if they wanted to portray themselves that way?

Corey: Absolutely. I've never seen an example of that, but yes, absolutely. I mean, they're a higher-density being, that they're manifesting out of nothingness in front of me as Blue Avians. They could probably appear as a human if they wanted. But I have not seen an example of that myself.

David: Well, and they ask you to read “The Law of One”. And if they are sixth density, then in “The Law of One”, they say that sixty-density beings are actually only Blue Spheres. They don't have any form unless they want you to see a form. That's right in there. So here's another . . .

Corey: Blue Spheres?

David: Yes. Yeah. So this could actually be one of the same Sphere Beings. And Hildegard von Bingen, of course, is really important because of many visionary prophesies that she had that foretold the coming of the ascension and the conditions that would appear on Earth during that process.

Her prophesies are right up there with Nostradamus, Edgar Cayce.

William: Definitely.

David: All those guys.

Corey: Yeah. I've never . . . I mean, when was this?

William: German mystic, 15th century, 16th century.

David: Yeah. She had a lot of prophesies that already have been proven accurate, remote viewing the future, seeing the civilization we were going to have and predicting ascension.

And isn't it interesting . . . I didn't know this until you brought this up, this guy actually . . . She said this guy visited her.

William: Yes.

David: And this is her illustration of that.

William: Yes. This is her visualization of this experience.

David: And he's coming in a sphere, a blue sphere.

William: He's coming in a blue sphere composed of concentric rings.

David: It's crazy. It's absolutely . . .

William: Right. It's the same energetic experience. And he's inviting her to: "Come join me. Come have this experience."

David: When I first started doing readings and I got in touch with these beings that were the Blue Sphere Beings, we were listening to Hildegard von Bingen Gregorian chant music all the time.

William: Oh, wow!

David: And when you play that stuff, the sacredness . . . It's like it's a portal. The music is a portal.

William: Right. It is. It establishes that sacred space.

Corey: Music changes your vibration.

William: Totally.

David: Absolutely.

William: Totally. Yeah.

David: I had no idea that she was visited by an angelic being like this. That's amazing.

William: Yes. Yeah. The "Man in Sapphire Blue", so she's emphasizing that he is in this blue sphere and he is a Blue Sphere Being.

David: And he had blue skin.

William: Yes.

David: Wow!

William: Yes, exactly.

David: All right, so **William**, let's have one more, because we're just about out of time. But let's just take one more slide and see what we got here.

William: Okay. So we looked at the transfiguration, where Jesus gives his initial demonstration. “Here's what you're all going to be able to do, drop your skin, become a light being, and open up this portal behind you.”

Then in the ascension, he actually ascends in this cloud. And that's the way that they describe it in the Bible is he went up in this cloud. And the key thing is in the Book of Acts is they describe him going.



Suddenly two men dressed in white, who are very mysterious, sound like celestial beings or angels, appear and say, “Men of Galilee, why are you looking into the sky?” As you see Jesus going, he's going to return exactly the same way he's just left.

So he's coming and going in this ascension cloud.

David: I've got to throw this in. This is too good. Peter Lemesurier, the guy that wrote “Great Pyramid Decoded”, has a whole section of the book where he explains that Galilee is a metaphor for our world right before it ascends, or as it's ascending.

William: Oh, my gosh! That's incredible.

David: Yeah. So men of Galilee . . .

William: Men of Galilee.

David: He will come back the way he left.

William: Men who are going to ascend . . .

David: That's crazy.

William: Yeah. And so in Christian art, they got this idea, probably from Egypt, that this ascension cloud is actually a portal or a gateway. And it's blue.

Corey: Yes.

William: And so here he is, on the arcing rainbow with the feet on the footstool in this blue sphere.

David: Clearly levitating.

William: Clearly levitating, going through the heavens in these concentric rings filled with light. If that's not a wormhole or a Blue Sphere that they're indicating here, I don't know what it is, right?

Corey: Right. I mean, yeah.

David: Well, that's all the time we have for . . . We want to thank you for watching. This is "[Cosmic Disclosure](#)", and we'll see you next time.

Cosmic Disclosure: Spiritual Ascension vs. Technology

Season 5, Episode 5

David Wilcock: All right. I'm **David Wilcock**. This is "[Cosmic Disclosure](#)", and we have a special guest here with us, **Corey Goode**, and also, of course, **William Henry**, investigative mythologist who is the spiritual voice on "Ancient Aliens".

And he's been out there as long as I have, bringing you all kinds of amazing knowledge about ascension. And since 2002, he's been very firmly on the heels of the Blue Sphere story. So we're having a stunning convergence now in which an investigative link that he's been tracking now for 13 years has finally come to fruition in people having experiences that link the past, the present, the future all together in a continuum of one phenomenon.

So **William**, welcome back to the show.

William Henry: Thank you very much. Glad to be here.

David: Corey, good to have you back, buddy.

Corey Goode: Thank you.

David: You're about 40 pounds light now, right?

Corey: Yeah.

David: I mean, you've been going through some amazing changes yourself.

Corey: I have.

David: Do you think that these changes that you're going through – people are noticing obviously that you've lost a lot of weight. Do you think that this has something to do with your contact with these Blue Spheres?

Corey: Absolutely.

David: Could you go into a little more detail?

Corey: I was asked to go on a high vibratory diet. And instead, I was scarfing down corn dogs and ignoring them and gaining weight. And last time I was here, I got food poisoning from eating meat and other things that I probably shouldn't eat.

And after that, my body . . . It's like my medulla oblongata shut everything off and I mean, I couldn't eat meat. I couldn't eat anything. All I've eaten since January is fruit – are berries, bananas. And I have to force myself to eat that. And the weight just poured off.

And I've been going through all sorts of other changes as well. It's been pretty incredible.

William: Good for you. That's great.

David: So this contact is creating a metamorphosis in you somehow - the contact that you've had since you and I started talking and all this stuff started to happen with the Sphere Beings. Something is changing in you.

Corey: Correct.

David: William, is there a historical precedent that when people have these phenomena happen to them that these sorts of changes occur with them?

William: I actually call it the light body effect. I had one person ask me one time, is that a diet? It's like when you start connecting with the Blue Spheres, with the light body concept, you do start to plug into a higher vibration and it will manifest in physical body changes.

When I really started heavily working into . . . with these rainbow body images five years ago, it also came at a time when I was newly married. I've lost 20 pounds myself. I can understand that. And I know part of it is the change of diet that my wife made for me - a higher vibrational foods. But I also know it's my constant interaction with these images of the light body and saying, that's the direction I'm going. And it literally manifests in a lighter body. That's part of the chain.

Corey: And you're just looking at the images. You're not doing this [holding hands up, palms out] in front of the computer, right?

William: Right. I'm not doing that all day. I mean, I'm just working with them all the time, and your values change. You just decide, "Okay, I'm really going to step this up, because it's very important." We are what we eat.

Corey: What we consume.

William: What we consume. And it really feeds the soul. We talk about this in my show "The Awakened Soul" here on Gaia – the importance of food as a vibratory input into the body and that kind of thing, and how the soul needs . . . it craves food. Just like the physical body, needs higher vibrational food, the soul also needs high vibrational food. It wants to contemplate its existence.

What am I doing here? How did I get here? How do I leave? These are the questions that the soul really wants to contemplate. And that contemplation is feeding it.

Corey: That's interesting.

David: Well, I want to point out too, one of the reasons why I chose to work here instead of taking other offers is that this network has such an amazing collection of health and wellness videos people can watch. A lot of people might only at first be interested in the surface information of, “Oh, I want to hear these sci-fi cosmic things about **Corey** being in space”. But then eventually as you get into this, you start transforming.

William: Definitely.

David: And then that transformation is going to include body, mind and spirit.

Corey: And everything's tied together.

David: Yeah.

Corey: Everything's interlaced.

William: Right. Right.

David: So it's all part of that continuum.

William: It's the ascension. You know, people think the ascension has to do with becoming immortal, like you've got all these technology companies now that promise immortality. Google. You'll be able to live to be 500 years. We don't want that. We don't want immortality. We want ascension. We want the light body. And you can't get the light body through technology. That's a little ahead of our conversation right now.

David: Well, now **William**, I did a whole eight-episode mini-series on this really remarkable guy, the second Buddha, Padmasambhava.

William: Oh, yes.

David: And what I went through in that was essentially describing there was some leaked information from a man named Tulku Urygen Rinpoche. He has a book called “Rainbow Painting” - probably the best book. It really gets into the data of how they activate the rainbow body, leaked from the Tibetan schools.

And one of the things he said was that if you can spend 13 years where every thought is a loving thought, which I'm not even on day one.

Corey: I can't go 13 minutes yet.

David: Ha, ha. But theoretically, if you can stay in that state of harmony and be meditating and so forth for 13 years, you activate rainbow body. You're done with your entire universal curriculum of evolution.

William: Wonderful. That's awesome.

David: And I know you've studied this too.

William: Definitely. Getting back to “The Awakened Soul” as well, one of the things I discuss in that series is the power of the sacred art and the image to trigger the light body within us.

David: Oh, wow. Wow!

William: It's an actual spiritual practice engaging the image and allowing that to trigger the blueprint within us for the light body.

David: Similar to the stained glass in the cathedral or merkabah.

William: Absolutely. Yeah.

David: Or a mandala.

William: Exactly. Exactly. And now we know the whole neuroscience behind this now, how it triggers the mirror neurons in the neocortex of the brain. The brain can't tell the difference between a real and imagined experience. So for example, if I'm looking at an image of Padmasambhava, as we're doing here in this thangka, in his rainbow body, that image is interacting with us.

And because Padmasambhava is a guru, an avatar, he can manifest through that image and activate our rainbow body. That's really powerful stuff.

David: Now, if we look at his body, we're seeing a vortex center in his head and another one in his heart.



William: That's correct.

David: Why do you think there's two instead of just one?

William: Well, for one, the swirling vortex at the heart is the open heart chakra, being of love.

David: Okay.

William: But then when you get into the detail of the image and you look into the forehead, look at the third eye. There's a blue sphere right there in the third eye.

Corey: Right where the pituitary gland is.

William: Exactly. He's meditating on the blue sphere or the blue pearl and then activating the blue sphere within himself that manifests as the rainbow body.

You know, one of the things about Padmasambhava that's so interesting too is that his name means “the lotus born”.

David: That's right.

William: And very often in this artwork, the lotus that he is born from is blue. And it's a Blue Sphere. So . . .

David: Incredible.

William: Wait a minute. Is it too much of a leap of the imagination to think that he's not born out of a lotus flower?

Corey: He came out of one.

William: He manifested out of a Blue Sphere, and that's why he's meditating on it.

David: Even to the point that you have angelic beings around the sphere, just like in the Christian and the Egyptian images.

William: Precisely. It's the same story over and over again. And so they're trying to get us to wake up to this concept by the repetition of it and just showing, “Okay, we'll show it to you from this angle. You didn't get it there, let's show it to you from this angle.”

Corey: Through this tradition and through this tradition.

William: Exactly. And then when you put them all together, as I do in “The Awakened Soul”, now you get this comprehensive picture. And it says, “Okay. Wow! This is profound.”

They describe it as a universal teaching. And what I'm hearing from you is that It really is universal.

Corey: Yeah.

William: We're talking it being interstellar. I mean, it's throughout many star systems.

David: So it's clear now that we have Egyptian, Coptic, Renaissance. We've got Hindu.

William: Tibetan.

David: All these different things are showing a perspective on ascension that is rooted in Christ. It's rooted in these positive teachings of service to others.

So **Corey**, some of these mystery school teachings seem to have been . . . I mean, obviously as

William's so eloquently describing here, there's a really great spiritual, positive core to them.

But then in modern times, we see people doing human sacrifice rituals. We see people doing outrageously evil things, black magic on a global scale, trying to openly promote Satanism, trying to promote Lucifer as a liberator.

Corey: Right.

David: And they seem to think of themselves as gods. And they seem to think that if they practice their religion, that they will become gods.

Corey: Well, I mean the Blue Avians pointed out that they had delivered this message three other times.

David: Really?

Corey: And that each time when they left the message with us, we corrupted it. Apparently, the negative forces, if they find something that brings light, they do whatever they can to cover that light or distort it in some way.

A lot of times they'll take the beliefs and bend them and morph them with their own. Or they will do whatever they can to taint the beliefs that are out there among the populace, to pull out the nuggets of information like we're being shown here.

David: Well, when they're saying New World Order, they're not saying that we're all going to be levitating and loving each other, right? Their idea of a New World Order is pretty dark.

Corey: It's extremely dark. Yeah.

David: What do they want?

Corey: Well, different groups want different things. There is one group that wants to wipe out most of life. You know, we've heard of the Georgia guidestones. We've heard of the mandate listed there: "Bring the population down to a manageable level." Real bizarre and . . .

David: 500 million people.

Corey: Yeah. Upsetting plans that they have.

David: All right. So **William**, I want to open this up a little bit, because **Corey** only vetted me out on the negative aspect of AI a year and a half ago, when we first started talking. You've been actually tracking a very interesting idea, which is there's an organic ascension that's the path of Christ, the path of the masters.

William: Right.

David: But then there's like this weird imitation of it that we may not even realize we are being steered into something that does change what it means to be human, . . .

William: Definitely.

David: . . . but in a very unusual way that most people really don't see how far this could go and how fast it could go there.

William: Right. Exactly.

David: So let's open that up a little bit.

William: Sure.

David: What have you found?

William: Well, I started back . . . it's kind of interesting, synchronistic, that when I really started coming into awareness of these Blue Sphere beings, or Jesus in the Blue Sphere and so forth, I was also doing research on what's called the Robe of Light. It's part of the Light Body Teaching. They describe the light body as the Robe of Light, the Robe of Glory, the Miracle Garment, and so forth. It's a garment. And it might be a tangible, actual physical garment, or it could be a symbol for a transmittable teaching.

Going back 5,000 years, I was seeing story after story of various figures that would put on this light body garment, ascend, but very often before they ascended, they would transmit this garment to a successor, like Elijah goes up in the heavens in a whirlwind, a portal. As he's going, he transmits this garment to his successor, Elisha.

So it's a transmittable teaching. Maybe it's a vibration or something that they're transmitting in this light body.

David: But a physical garment could be used in art to represent that.

William: To symbolize that. Yeah. Exactly.

David: Right.

Williams: And so this is 2002. The US government in that year releases a report. They had gathered all these high tech titans, giants, in Hawaii, major conference in which the US government said, “Here's what's going to happen. Between now and 2035, four separate technologies, bits, atoms, neurons and genes, – computer science, nanotechnology, neuroscience and genetic technology - are all separate disciplines and technologies.

The government is saying by 2035, we want all those four to become one. And it's going to be aimed at the human skin: the creation of a new human skin.

I'm thinking, “Wait a minute!” This sounds exactly like this robe I've been tracking all these years, like they're going to use this technology to create a new robe of skin for humanity. And the very first manifestation of this that I noted – and I documented this in my book called “Cloak of the Illuminati” -

was at MIT, where they were building the super-soldier suit, the new suit of armor, the exoskeleton.

That's the first entry into saying, "Wait a minute. We are going to change the human body. We're going to . . . " It's called transhumanism, of course, where we're going beyond human.

Whereas in the ancient world, they used to ascend by organically putting on this Robe of Light, now the US government was saying, "We're going to fuse these technologies into one, aim it at the skin, and now we're going to have a new version of humanity.

Corey: You know, I never made the connection with all the time I've spent with the AI issue. I've never, and I've heard of ascension, of course . . . Everyone has. I've never made that connection of a mechanical or technological ascension.

William: Right. Right. It seems to me that we have in our core a desire, maybe even a program to ascend. And whether people at Apple, Google, and these other tech companies that are involved in this know it or not, they are answering this ancient call to transcend our flesh, to turn it into light.

And their version of this is, "Oh, yeah. We'll do that. It's going to be digital light."

And the problem with this is that if you go down this road, free will goes right out the window, because part of what Google's plan is is to create a synthetic neocortex. When we take their chip, we will link our brain, our neocortex to all 7 billion other neocortexes.

Corey: A true hive mind.

William: A true . . . In fact, **Corey**, that's exactly the word the government used in this report. They want to promote the idea of the hive mind once this technology is in place. So they laid all this out. And this is in my book "Cloak of the Illuminati". Anybody can go online and get that book.

Corey: When was this book published?

William: 2002.

Corey: Wow!

William: And then my 2003 book, “Oracle of the Illuminati”, is where I started making the Blue Sphere correspondence. So I've been looking at both of these questions for the past, whatever, 13 years.

And I used to think, “Wow! Okay. So they're saying 2035.” Now, what I'm hearing from people in my audience is it's not 2035. It's 2020 is what they're saying is when they were going to see this dramatic acceleration of this AI technology brought online.

And people are going to be required, mandated, to take this technology into their flesh. So I've been out trying to warn people about this and say, “Look, here are the choices that are ahead of us.” And everybody has free will.

Corey: Right.

William: Maybe some people are going to opt to have this technology implanted. My feeling is that, where's the soul in this? Because what we're talking about here with these four technologies, bits, atoms, neurons and genes, are simply technological versions of earth, air, fire and water – the four elements that we're composed of.

David: Right. Well, I want to expand this a little bit, **William**, because we're saying that humans have a desire for transcendence. Right?

William: Yes.

David: There's a desire for ascension.

William: Yes.

David: And I think on some level, if we can maybe even make that simpler, there's a desire for an experience of the cosmic.

William: Yes.

David: And I think ultimately that's a desire for love. And when we get stuck in addiction, addictions are essentially a thirst for love, but we're getting it through some kind of substance or some kind of compulsive behavior.

William: Right.

David: And you look at what's happening with people with their smartphones now.

William: Yeah.

David: They're in love with the phone.

William: Yes.

David: They're being drawn into a virtual world.

William: Right.

David: Now, **Corey**, what is this AI agenda? I know some people might not have seen that show. They might be watching this for the first time. **William** hasn't heard this before. Is there an AI? Is there some ancient AI that has an agenda for us?

Corey: Yes. And this AI has fulfilled this agenda in multiple galaxies. It implants itself, usually through a Trojan horse, into our society.

David: What would that be, though? What's a Trojan horse?

Corey: Well, it would be . . . Let's say they had already overtaken another civilization. That civilization has gone through the end part of what I'm about to explain. They've created technologies, androids for the AI signal to inhabit. And then after they do so, it turns on them, just like in "Battlestar Galactica", destroys the flesh, and then takes over and then sends one of their spaceships that they've build to crash on, let's say on Earth, a planet like Earth, that happens to be just about at the developmental stage to where we're developing technology, and then boosts us to where they have a pond to swim in, because technology is the water that this fish swims in, and then repeats the process here – basically like a giant virus going from solar system to solar system.

William: So let's say that was the Roswell crash. They discover the beings on that are cyborgs. Then all of a sudden, from '47 to about 1960, they're researching all this. Then all of a sudden, what was it, 1961, '62, NASA puts out its first cyborg report. Guess what, kids? Flesh and blood can't inherit the Kingdom of Heaven. That's what the Bible says. There's a boundary.

Our flesh and blood bodies are too fragile to cross the barrier of space-time, to go out into deep space. So that means just like the beings in the Roswell crash, we're going to have to become cyborgs. And

NASA initially puts this report out then immediately retracts it in 1962 and kind of says, “Oh, we were just kidding about all that.”

But I don't think they were kidding.

Corey: NASA's known for being big practical jokers.

William: Yeah, right. This is DARPA today, where the Defense Advanced Research Projects Agency is feeding this technology into these corporations. And now we're starting to see it at the consumer level, and people are beginning to accept it.

But ultimately to me, what they're trying to do is turn us into cyborgs in order to take us into space.

David: Now, **William**, you said something so provocative when we were on the panel with George Noory, and he also has a show here on Gaia. You said that these globalists have actually come out and said that it will be illegal to hold a body, that you will need to upload yourself into some sort of Facebook matrix or mainframe.

William: Yes. This is one scenario. What people don't realize about Facebook is how primitive it is. We're in the very first stages of it.

Mark Zuckerberg just yesterday was at a major conference where he proclaimed that Facebook is a quarter of the way towards its goal of having every single person on Earth online and connected to Facebook.

And by that time, what they have in development are super-computers that will take every keystroke, everything you've ever put on Facebook, every photo, every image, every keystroke will then be animated in a holographic kind of version of you so that your successors will be able to interact with you.

David: Wow!

William: It will be just as if you're sitting with this personal view of yourself. And ultimately, what they're saying is that this could be the scenario that to depopulate the planet, they're going to convince us that. “This physical body, you really don't want one of these things.”

David: “It gets sick. It gets old.”

William: “It gets sick. It smells. You've got to take care of it. What you really want to do is clone yourself. But then you really don't want to clone yourself either, because that's only temporary. What you really want, **David**, is you want an avatar body. You want a . . . We're going to scan the contents of your brain. We're going to create a perfect avatar version of yourself that's going to live in a simulated reality that's so much better than this one that you don't need to come back here. And you will live forever in this simulated reality.”

And they believe that this will be a choice that kids are really going to want to make. And they will gladly drop their . . .

Corey: The sad thing is with technology and compression, they could put you in this technology for 45 seconds, and you could experience an eternity. And then they could delete you and put someone else in.

William: Exactly. And so this is the great threat that's out there, that we're all going into this new game, that they're way ahead of us.

I mean, Facebook already knows that what you're looking at here is just so primitive. But they already know the plan is to be able to create these animated versions of you, these holographic versions of you that will live in this simulated reality that you will want to go into.

Now the thing is that, will it be mandated? Will they be able to do that? That's the big question. Will the introduction of this technology, especially interfacing with our body, be by choice? Probably it will be for a time.

But the big threat is that it will no longer be choice after a few years. It will be mandated because part of Obamacare is that all of your medical records have to be in digital form. And I have been told by lawyers who wrote the law that on down the road what they mean is that that information will have to be inside your body in a chip form, . . .

Corey: Right.

William: . . . which is mandating that you have this chip. And they're going to come along with that and say, “Well, you know, you're probably going to resist that. But, hey, you know, your flimsy little

single brain here really isn't that great, because what Google is developing is a chip that will link your brain to all other 7.5 billion brains on the planet.”

And their promise is that you will now have this super-power of their synthetic neocortex, where you will have the power of all 7.5 billion brains on the planet.

This is like Satan taking Jesus up to the top of the tower and saying, “And all of this can be yours.”

David: Well, I wanted to . . . You just picked up on what I was thinking. One of the other insiders I've been speaking to . . . He's not going to come forward. We're never going to get him on the show. But he's the guy that's been leaking information to Richard C. Hoagland for a long time. And he's given me some really big briefings.

And in his view, in his program, the people that are in that military space program, they believe - they're Christian – and they believe that the beast, that Satan is an AI and that it has to stay in electronic machine intelligence form because it can escape – and this is his words, not mine - “it can escape God's judgment”.

William: Ah! Right.

David: It can be free. As soon as it tries to go into flesh, it becomes subject to karma, to reincarnation and to judgment.

William: Right. Well, what I've just described here with this long-term view of creating this avatar version of yourself, this digital version that will live in the simulated reality, that's the fulfillment of prophecy in the Book of Revelations about the emergence of a new human who will live in a new heaven and Earth. But in this case, it's a technological one, a simulated reality.

And whether these companies in Silicon Valley, the digerati, realize that this is what they're fulfilling or not, I can't say. But what I've been trying to do over the years is to say, “Look, guys, some of this technology can be good.” But here's the thing. When we're dealing with bits, atoms, neurons and genes, as I said, that's earth, air, fire and water. What's missing in this is the fifth element, spirit, love.

David: Yeah.

William: Steve Jobs believed that he could infuse spirit into technology. Ray Kurzweil, Google's tech guru, believes they can do the same thing. I don't think so.

But my advice to people on this issue is that if you have developed your soul's capability to where you have the power of mind over matter, then in a life and death situation, you might consider interfacing your body with this technology – letting it under your skin. If you can't control this technology with the power of your mind, then never consider allowing them to put this technology under your skin. That's my advice to people.

So what I'm saying is, guys, it's time to uplevel our soul's capabilities.

David: We don't need technology.

William: Absolutely not.

David: Yeah.

William: Absolutely not. I mean, we have this organic circuitry already built in us. And what they're proposing in Ray Kurzweil's own words is “We're perfecting God's creation”. In their view, our body is an unfinished symphony. It's a cake that needs icing. And Google and Apple and all these companies are saying, “We're going to put the icing on the cake here.”

Corey: Well, actually, we've been looking at some of that technology in some of the images. I mean, to me, that's ascension technology, but of a spiritual type.

David: Sure.

William: Exactly. Exactly. So what I say to people is that we have two choices. You can become a pink elephant and stay purely organic, raise your soul's vibration, change your diet.

Corey: Who wants to be an automaton, you know?

William: Right. Or you can go gray, because this technology, I mean, the Greys were the ones in the Roswell crash, right? I mean, that's one of the theories. And they're the androids. They're the borgs. And as you so beautifully said, they could be the Trojan horse that brought this technology in – the transistor, laser, all those technologies that emerged from the '50s that have now culminated in this AI phenomenon.

How did we develop artificial intelligence in less than 50 years? I mean, come on.

Corey: Right.

David: Well, now **Corey**, you also said that this is a very widespread issue, that it's like AI versus biological. And it's gone on for eons, all throughout the universe.

Corey: It's gone on more than millions of years. It's gone . . .

David: So are the things that **William** is saying, is that the standard operating procedure of this AI?

Corey: Yes. It's giving me the creeps. I'm sitting over here and it's giving me the creeps.

William: Yeah.

Corey: Because it's exactly . . .

David: Well, what's the endgame? If we did what . . .

Corey: He just gave the endgame.

David: But what happens to us if . . . Let's say some people decide, "Okay, I think I can handle this. I want to try it out. I want to have bulletproof skin. I want to be able to glow at night. I want to be able to have access to Facebook in my brain? What happens to us?"

Corey: They begin to see flesh and blood beings as a virus or a threat that consumes all of the natural resources, doesn't live in symbiotic relationship with the environment or anything around them.

"What's their use? We should do what we do with viruses – wipe them out."

William: Right.

Corey: "It'll be better for the planet. It will be . . . It's just logical."

David: Right.

Corey: And then after that, they move on to another planetary sphere and repeat the process.

William: Right. And the answer to me is not Artificial Intelligence, AI, it's AI – Ascension Intelligence. We've got to link our consciousness with the Padmasambhavas, the Christ, because we can interface our consciousness with them. And I think as people go on this path, they're going to realize, “I don't need this technology after all.” And they start to move away from it.

And so I think that's the answer – is massively educating people about our organic ascension. And as you do that, you just decide, “Yeah, I don't need all this crap. I don't need the technology because I can do it myself with my own consciousness, with the power of my heart and my mind united. I, in my soul, is capable of doing all of these things that they're trying to mimic technologically.

And as **Jay** Weidner first introduced to me is this idea, John Lash as well, is that one of the keys that these Grey Reptilians, or the Grey beings, use is simulation. They want to introduce this technology in the simulated reality in hopes of snatching our souls from us, because as technological beings, they don't have souls.

It's the one thing you can't get from technology is a soul. And that's what they're looking for.

David: Well, on that note, **William**, I want to thank you for being here.

William: My pleasure.

David: This has been truly incredible information.

William: Thank you. Thank you, **Corey**.

David: Could you just again give us a brief description of what do you have for us on Gaia that people can check out and how does this tie-in to what we've been discussing?

William: Yeah. Thank you. My show is called “The Awakened Soul: The Lost Science of Ascension”. I'm going to take you through the beginning, middle and end of the ascension process . . .

David: That's awesome.

William: . . . giving you a real historical foundation to build from, some practical ideas of things you can use. It's based on the divine feminine as well as the masculine – a real balance. Lots of images that you're going to be able to really get this idea of ascension.

And if people want to know more about my views on this technology, they can get my free e-book from my website, www.williamhenry.net. It's called "The Singularity is Near". I've given it away free.

I intended that anybody who wants it just get it. Share it with as many people as possible, because most people are unaware of what we just discussed about, except the work that you're doing here and you guys have discussed it. We need to get this information out there so people are really aware of the choice that we're making right now, because there's no turning back, is there, **Corey**?

Corey: There's not.

William: Yeah.

David: Well, this has really been blowing my mind. I hope you've enjoyed it at home. We're going to be back next time with another episode of "[Cosmic Disclosure](#)" for you. I'm [David Wilcock](#). Check out **William Henry's** new show, and we'll see you here next time.

[Cosmic Disclosure: Plasma Beings and Etheric Entities](#)

Season 5, Episode 6

David Wilcock: All right, welcome to "[Cosmic Disclosure](#)". I'm your host, [David Wilcock](#). I'm here with **Corey Goode**, the insider's insider. And in today's episode, we're going to cover a broad topic.

We've only really been talking about extraterrestrials up until now that have biological forms, that would appear to have a hominid appearance. They might not be human, but they're human-like.

In this episode, we're going to talk about etheric beings and get into all the different avenues and roads that that leads us down. So, **Corey**, welcome to the show.

Corey Goode: Thank you.

David: I guess the first thing that we could start with, keeping it simple, is just a brief recap about . . . in Solar Warden you studied some beings that were apparently just plasma?

Corey: Yes, beings that lived off the electric field of Jupiter that were plasma-based that mainstream science would not even consider life.



Plasma Beings

David: The conventional biological view of life is that it has to eat. It has to excrete. It has to have locomotion. It has to have respiration.

Corey: Right.

David: And it has to have sentience. So how do you get eating, excreting, locomotion and sentience in these plasma beings exactly? How do they demonstrate signs of life?

Corey: They were definitely sentient. They showed signs of preservation of life. They did not like or appreciate being experimented on or having pieces of their bodies harvested for experiments. They would avoid craft coming towards them. So that showed a sign of intelligence.

They reproduced sort of like mitosis. And they used . . . I don't exactly know the form of locomotion they used, but they would travel through the electromagnetic field of the planet.

David: Was there anything visible about them at all? Or are they almost completely invisible to the naked eye?

Corey: Almost completely invisible to the naked eye.

David: Did they have an infrared heat signature or something like that? How did you know where they were?

Corey: I don't believe it was infrared, but there was a type of imaging that they used that allowed them to, the scientists to, observe them.

David: Okay, I guess that's important because I had kind of seen them as maybe being like a glowing plasma.

Corey: It's not a giant plasma thing you can see with your physical eyes unaided.

David: Why do you think it was considered so important that you guys spent so much time going out and looking for these things?

Corey: It was new. It was science. And it was a science vessel.

David: Okay. Now, there's a whole science in the esoteric community. Jose Escamilla talks about the rods, things that . . .

Corey: Oh, yeah. Sky fish?

David: Sky fish, right. These things that sometimes seem to show up on cameras. Now, I'm not entirely sure. Sometimes I've wondered is that insects that are flying by, but they're kind of smearing out on the camera? So since we're talking about etheric beings, and that's a big topic in the alternative media, do you have any information about that one way or the other?

Corey: Not that one in particular, but there are similar type of plasma-type beings out in space. So I can't say that those aren't real.

David: Okay, there's a very important footage that I want everybody to see now. And we can roll it as I'm talking.

Video: NASA U.F.O. FOOTAGE (FULL VERSION) (17:52)

<https://www.youtube.com/watch?v=8njYpyAkMp8> Uploaded on Sept. 3, 2011

This is footage from the space shuttle where there was a tether experiment to a tethered satellite. And they have this long, electro-conductive wire out in space conducting energy, electrical energy, to this satellite.

And as they did this, all of these spherical, glowing, orb forms, with kind of like a hole in the middle, cluster around the tether.

Now, a lot of people have called that a UFO sighting, but it looks like these are some form of etheric beings. What do you think we're looking at here?

Corey: That's most likely one of these life forms that live in the Earth's electromagnetic field. Every planetoid that has an electromagnetic field is going to be a part of their feeding ground as they travel around. And some of them spend their entire life cycle in one sphere.

David: Why do you think they would be attracted to a wire that has an extremely high amount of electrical energy running through it?

Corey: Their food source is the electromagnetic energy, and if it's causing some sort of pulse or is interrupting or pulling from that source, it's going to get their attention.

David: So they're feeding.

Corey: Yes.

David: Interesting. Do they go after satellites, like the geostationary satellites that we use for cell phones?

Corey: I've not heard of that, no.

David: What about craft, like the space shuttle or X-37B or space program?

Corey: I have not heard of encounters of them going after a spacecraft or collisions or any issues like that.

David: Okay. So far what you're talking about to me sort of sounds like an amoeba or a bacteria, a very primitive, very low-level life form of some kind. Are there any signs of advanced intelligence in these things? Do they do anything that suggests that they might be smart?

Corey: There was a lot of speculation on that. If they are highly intelligent, then they are not paying any attention to us or wanting to communicate with us, but it really seems like they are focused on just living out their life cycle, reproducing, just having their life cycle.

David: So it's almost more like a bacterial life.

Corey: Right.

David: Okay. So this topic of etheric beings goes in a lot of different areas. We've also . . . To go to the far opposite end of the spectrum, you said that the Blue Spheres themselves were explained to you as some type of etheric being, not a technology.

Corey: Right. It's not a technology. It was explained that they are the highest density of the Sphere Being Alliance. They said they're said to be ninth density beings that appear as orbs or spheres. And the size does not matter. I mean, it can be the size of a ping-pong ball, or it can be so large that it can contain an entire solar system.

David: Right. That level is going to be difficult for some people, because we tend to think of intelligent life as having a body. Where is the dividing line between biological life and etheric life?

Corey: If it's sentient but doesn't have a corporeal body, then it's going to be etheric life.

David: Okay. But specifically, do these etheric beings start out as biological and they graduate into energetic? Or are there beings that have an entire lifecycle that remains energetic the entire time?

Corey: The answer is both. Some of them have had a physical body. Some of them are said to be from somewhere called the outer realm, or another reality or something. So it's a combination. There are a lot of different types of non-corporeal beings.

David: Let's talk a little bit about some of the negative ones, because that's obviously something we want to get into. One of the topics that we had on our list for this episode was shadow beings. So what are shadow beings?

Corey: Well, shadow beings can be several different things. A lot of times when people see shadow beings, they are beings that are coming in to observe them. Or they can be beings that come in that are trying to cause fear so they can feed off of the loosh or the energy from the fear. And some of them are entities having an out-of-body experiences to do the same thing, such as Reptilians having out-of-body experiences, visiting people, and scaring the bejesus out of them so they could feed off of the energy they release.

David: So there's a shadow that people see? Just walk us through what someone would experience if this happened to them.



Shadow Being

Corey: Okay, well, this is definitely first-hand knowledge. A lot of times out of the corner of their eye, they will see the shape of a human walk by or duck into the next room real quick. And, you know, you'll jerk around and look and just miss it.

And it's happened with my children. They've seen them to where my daughters looked up, and they just stay there and let her observe them.

David: Like a silhouette?

Corey: A silhouette of a human.

David: What does it look like? Do you see a face? Do you see skin?

Corey: Looks like a three-dimensional shadow.

David: Just a shadow? Okay.

Corey: Right.

David: I spoke to a lot of people 'who took LSD', and 'other people' who I spoke to told me that they would see these things quite often. So do you think that when people take these mind-expanding, psychedelic drugs . . .

Corey: Yeah. It drops the veil.

David: . . . that it makes these things more visible?

Corey: Uhm. Yes. And that is one of the things that they experimented with, giving people psychotropic drugs, trying to find out what they will experience, what type of etheric beings they may encounter and, depending on the person, what's going on in their life, whether they're positive or negative oriented, they may experience negative or positive etheric beings.

David: What would someone actually go through if they had a positive etheric being experience?

Corey: A lot of times they'll be given spiritual knowledge or teachings or just real blissful emotional feelings.

David: Okay. So what is the agenda of these negative beings? When they're appearing in front of people, what's their endgame? What's their goal?

Corey: Some of them are there just to feed off of your energy. Some of them are just there to observe. And some of them have been put there as entity attachments by people using like dark magic, like people in the Cabal.

If they can't control somebody by using mind control or using other methods, they will use entity attachments and use those to cause people to go into reactionary states of mind.

David: Okay. So this is actually a really, really big topic.

Corey: And they also use these entity attachments as gatekeepers when a person starts to . . . If they can't keep a person from accessing memories, they will use them as gatekeepers to where if they try to talk about the memories, the entity will cause them to go into all kinds of anxiety attacks or any number of things.

David: What is the relationship between trauma-based mind control, psychotropic drugs and the use of these entities? How does that actually work in this MKUltra technology?

Corey: Well, they use a combination. They're going to use all of the above on people, but different people are resistant to the three things that you mentioned. They usually use them all together to get the desired effect, because using just one is not going to do the trick.

David: Okay.

Corey: Using trauma is also one of the ways that they implant these entity attachments. Physical, sexual trauma is one of the ways that they use to implant these.

David: Does the trauma make someone more receptive to an entity attachment somehow?

Corey: Well, the trauma itself is the glue that binds.

David: Okay. What is the type of being that is going to do this? Are you saying that these beings that are attached to people, that they just live inside that person? That's their whole life is like a parasite in a host?

Corey: Right. Yes.

David: Do these beings have multiple people they live in at the same time, or do they focus on one?

Corey: I don't know the limitations that these etheric beings are under . . .

David: Okay.

Corey: . . . but yes, they're definitely assigned to people and will be dedicated to whatever they are assigned to do. So if they're assigned to a person to keep them from talking about certain topics, they will be very dedicated to that, and any time the person even tries to broach the topic, they will be thrown into whatever this entity uses as a tool, a panic attack or go into confusion or fall asleep.

David: We hear multiple stories of shamanic practices saying that these entities anchor to certain parts of the body that might have pain or might have disease conditions or kind of like a rottenness inside the tissue, some kind of putrescence. Could you talk about that a little bit?

Corey: The information that I saw is that some of these entities can also cause people to have, over time, cause them to have tumors and weird things that show up in their body where the attachment is. That's definitely in line with what I heard.

David: So we have different words for these kind of things. I've heard them called engramic memories. I've heard them called somatic memories. Massage therapy gets into this. Acupuncture gets into this. Can you just personally confirm that these entities do anchor to certain parts of the body and that there would be usually pain or disease conditions in that particular area?

Corey: Yes. They're going to be anchored to different parts of your energy field. And when they do, they're sucking energy from your body, and that is making you ill. And in that area, you will have a physical manifestation, and it can be pain, it can be lesions, it can be any number of things.

David: But what did you hear about how to actually solve this? This is going to freak people out . . .

Corey: Right. Right.

David: . . . and I'm trying to give them some hope here.

Corey: Well, I do know that shamans have figured out a way of getting rid of them. And it's something that Western medicine doesn't even consider in any equation if a person is ill or having psychological issues or anything. They're not going to consider that at all. But shamans, that's going to be one of the first things they're looking for. They're looking for . . . there's something spiritually that's manifesting itself physically.

David: What do you think about the Native American strategies of burning either sweetgrass or Palo Santo wood or sage to create some kind of smoke that makes it less friendly to these entities?

Corey: I think that probably something's happening to change the vibration, to make the vibration sort of putrid for these entities to where they can't co-exist with it. I don't think it's the actual smoke that's making things uncomfortable for them. It's more of a change in vibration and energy related to the burning or the use of these items.

David: Well, that mirrors what's actually said in “The Law of One”. They mention two strategies. One would be hanging up garlic if you think that there's entities in a room or you're moving into a new space and you're worried about entities being in there. Crushing garlic, and really the intent being that you set your intent that that's driving them away. And then the garlic becomes a focal point for your intent.

Corey: We don't understand the power of our co-creative consciousness. You can will them away. But if you're told you can't and you're convinced you can't, then you won't be able to.

David: And another thing that “The Law of One” said is to pour salt along the doorways and the windows and then charge that salt with the intent of the purest love vibration, and that will block entities from being able to get back in once you drive them out. Do you think that the salt crystal, as it's explained in “The Law of One”, could have some sort of storage capacity, some sort of vibrational ability to hold the intent?

Corey: That's absolutely possible because crystals are used to store all sorts of information, information as in data and information as in actual beings can be stored in crystals.

David: Now, let's talk about the pyramid for a little bit. You saw some of my episodes in “Wisdom Teachings” about pyramid technology.

Corey: Right.

David: When people go into the Great Pyramid, this technology apparently was made by an earlier incarnation of the Sphere Beings. If you believe the Sphere Beings are the Ra of “The Law of One”, they built the Pyramid. So you have this sarcophagus, and the idea is that you go through a purification ritual. Someone's holding a crystal. All of these negative karmic attachments that you have, actual entity attachments, are purged in the pyramid as a result of going through some sort of psychodrama

where you have to forgive the negative things that happened and forgive yourself and forgive the people that hurt you.

So if that's such a big part of the technology, is there a psycho-emotional component to these entities? Are they attached to us because of our unwillingness or inability to forgive?

Corey: Yes. Emotions have energy, and that energy will have, I guess, sort of like mass. And that is something that these entities can hold on to and use as an anchor.

David: Like a food almost.

Corey: Used like an anchor as well.

David: Right.

Corey: And when you let go of that emotion and energy, they don't have that anchor any longer.

David: The main place in "The Law of One" that these entities get attached to us is in our digestive system. Because with all the bends in our intestine, you have this impacted material that's waste products that could be in your colon for 20 years. And those entities can live in there.

Now, you've been going through a really phenomenal transformation yourself. You've been losing a tremendous amount of weight. And it all happened after you touched hands with Kaaree, is kind of how I'm seeing it. Something has been changing in you. So do you think that your own weight loss . . . Do you feel as if you've had a deliverance from these entities to some degree, that you've shed them?

Corey: Well, I definitely went through a period when I first was starting to discuss everything that we've discussed in this show . . .

David: Before we did the show.

Corey: Before we did the show. Before I even really began to tell you all the deep details of all of this. I had the memories. I could revisit the memories any time I wanted, but if I ever tried to verbalize them, I would start stammering. I would get very anxious or very tired and forget I was even going to talk about it.

David: Wow!

Corey: I ended up doing a remote viewing of my light body, and I visited this orb that was in my light body. And with my mind, I wanted to see inside of it, and about a quarter of it went clear. And I saw what looked like almost like a frog sitting all curled up inside this little sphere – inside my light body - but its head was squished.

It was like a frog with its head kind of longways like this. And the first time I saw it, it freaked out, and it said, “You'll forget me.” And I forgot it.

David: Wow!

Corey: And so I was unable to talk about this stuff until I was able to go through the process of going through a deliverance of getting rid of the entities. And I did it using my background and the knowledge I knew by calling on the name of Jesus. And that's all I knew. And when I did, I actually with my physical eyes saw things just – fwoo, fwoo, fwoo, fwoo – leaving me.

David: Wow! That's crazy.

Corey: Like I actually saw shadows leaving me. And afterwards, I could talk about it. Overnight, I could talk about it.

David: This is interesting, because multiple insiders I've talked to . . .

Corey: It gives me . . . Just talking about it now just really gives me the shivers.

David: Multiple insiders I've talked to, you try to get them talking about certain subjects, and they immediately start falling asleep. They get distracted. They go on tangents that have nothing to do with the question.

You wait 20 minutes before they let you in, and then you try again, and they go off and do it again.

Corey: And it's one of the things in the Secret Space Program, even. These dark practitioners will attach entities to people to keep them from talking about what they're not supposed to talk about or looking into things that they're not supposed to be looking into - to keep them in line, to control them.

So these dark Cabal-type people, they use these entities as tools.

David: Would you agree that doing things like exercise and healthy diet can help to cleanse this stuff? Is that part of what these Sphere Beings have told you to do?

Corey: Yes. When you are eating higher-density foods and you're keeping your body, I guess, in shape and cleansed, all the toxins out, there aren't these lower-density particles or areas for them to hold onto and use as an anchor. And you are also . . . They are not compatible with your energy any more.

So having a high-vibratory diet and making sure that you're trying to put yourself in a positive environment as much as possible will limit their ability to hang on.

David: Some people watching this show, "Well, I don't have any entities. I'm clean."

Is that a natural thing that the ego is going to want to say, that you're totally free of these entities? How widespread is this? Does everybody have some attachment at all times?

Corey: Most people have some sort of either attachment or some sort of connection going on. If you have any trauma, physical or mental trauma, that affects your daily life, then there's a very good chance there's also an entity involved. Not always, and this is not something that people need to completely dwell on, either.

If we begin to change our diet, do the things to make the changes in our self, forgiving others, forgiving our self, that releases the energy that these emotions have created, and these beings will not have the ability to hang onto you.

And the Blue Avians have made it clear that here in the future, with the solar events that are happening and the energetic changes, these etheric beings are not going to be able to stay in our reality. They're going to be 'pushed back out to the outer realms', is what they said. They just will not be able to co-exist with us any longer.

David: What will happen to the people who are the hosts for those beings?

Corey: Good question. Everyone has someone in their life that, I guess, sort of will treat them badly and get off of . . . I guess sort of like a vampire. They'll vampire off of you.

David: Sociopaths, psychopaths.

Corey: Sociopaths, that kind of thing. A lot of those people have entity attachments, and these entities are in a symbiotic relationship. These people are being sociopaths, mistreating people, drawing their energy.

This energy is going up to that entity, and the entity is sharing it with the person that is hosting the entity. If the entity is removed, the person goes through withdrawals, just like a heroin addict would if they went cold turkey stopping the drug.

David: So is there any last thing you'd like to leave people with as far as . . . First of all, let's not demonize this, right? This is something that happens almost to everybody.

Corey: Right.

David: So it's not like we want to start turning against people.

Corey: Yeah, you can't start pointing fingers and saying, "You have entity attachments. You have entity attachments." Everyone's going to be affected on some level by this.

David: But it is possible to use these spiritual teachings to purify yourself with diet, consciousness, and become far less affected by this than . . .

Corey: Right. And it's a daily struggle, because you're going to run into people on a daily basis that are infested, and you're going to have to fend them off on a daily basis.

David: Did these Sphere Beings say that eventually all these entities will be gone as we go through this ascension process?

Corey: That's what they said. They said that the energy changes that are occurring were going to be incompatible with these entities, and they were going to be driven back to the outer realms where they came from.

David: Well, that's awesome. Well, that's all the time we have for in this episode. Very interesting stuff. The power is in your hands. And I'm [David Wilcock](#). This is "[Cosmic Disclosure](#)". I thank you for watching.

Cosmic Disclosure: Veiled Threats and Open Disclosures

Season 5, Episode 7

David Wilcock: All right, welcome back to “[Cosmic Disclosure](#)”. I'm your host, **David Wilcock**, and I'm here with **Corey Goode**. And you've been asking us and asking us and asking us for this, so this is the moment you've been waiting for. We are getting right down into it with the new updates, what is going on since we last were talking to **Corey** about the latest, greatest things that he's been experiencing.

And so I'm going to bring you up to date with where we were so that we have some orientation, you understand the jumping off point that we have, and where we're going.

How are you buddy?

Corey Goode: Doing well, thank you.

David: All right, cool. After you got through this epic tour of the Inner Earth, you met Kaaree, you have the library, you didn't immediately segue into telepathic contact with them, in fact, I remember you telling me you did not want them to contact you telepathically. You insisted . . .

Corey: Right. Yeah, I . . . Kaaree communicated with me through a telepathic teleconferencing kind of situation. And I have always demanded face-to-face contact, because there's too much that can happen with the information – you can be tricked, who knows.

David: Could you just describe what this telepathic teleconferencing was like? What did you experience?

Corey: Yes. It was like we were pulled into a area. I was not . . .

David: Well, who's “we”, first of all?

Corey: Well, she originally contacted me herself. It was just her and I.

David: And this is in your house, like you're lying in bed?

Corey: I was lying in bed, yes.

David: Were you told that you were going to have a meeting?

Corey: No.

David: Okay.

Corey: It was a surprise.

David: And was it the same time that you would usually have these meetings with Blue Avians, like 1 o'clock in the morning?

Corey: No. I don't even . . .

David: It could be any time.

Corey: Yeah, it doesn't matter.

David: All right.

Corey: And after I made that comment to her, she just kind of smiled at me like I was a child and said, "Before long all of your people will be communicating in a similar manner."

David: So she just kind of dusted off your concerns about there being some sort of AI influence or Cabal influence, Draco, tampering with it.

Corey: Trickster beings, whatever. Yeah.

David: So could you just please describe for us a little bit more about . . . Is this like a discontinuous, out-of-body experience?

Corey: It was very similar, yes.

David: Really?

Corey: When I would look at her, she'd be sitting in one of those egg-shaped chairs.

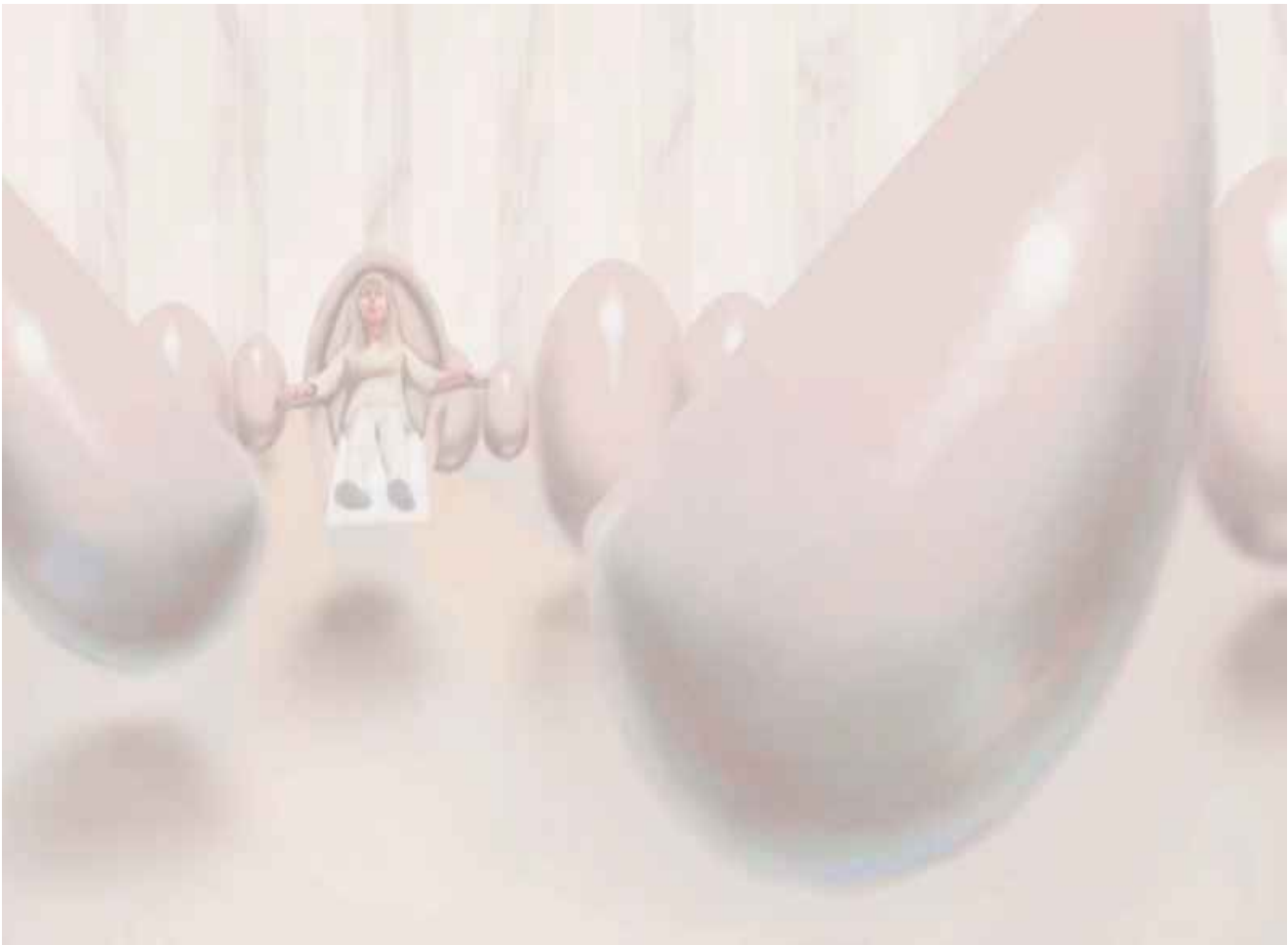

David: Right.

Corey: And I would just be standing there. And this kind of . . . I don't even know how to describe it. It's like a teleconferencing kind of room where you're kind of meeting. And we would converse. Other times . . .

David: Almost like in “The Matrix” where Neo and Morpheus show up together in this white room.

Corey: Yeah.

David: And they're projected into this, but they're able to have this conversation.

Corey: Right.

David: Interesting.

Corey: Yeah, similar to that.

David: And was there any equipment in this teleconferencing room?

Corey: No.

David: How big was it?

Corey: Well, the room seemed to just go on. It was . . . It went off into like light. I couldn't see walls.

David: Wow!

Corey: I couldn't see corners of the room. And the only equipment, I guess, in the room would be the egg-shaped chair she was sitting in. And she communicated with me mentally back and forth as we were together in this . . .

David: What did you talk about exactly during this meeting?

Corey: She was kind of . . . This was kind of a breaking the ice kind of showing me this new way of communication. And she let me know that Gonzales was staying with them. I wasn't given a reason. And he was down in the Inner Earth in their city living with them for a number of weeks.

David: Okay. Was there any contact that you had with the Blue Avians or with the Inner Earth beings after your Inner Earth visit before this meeting in what we'll call "the Construct"?

Corey: Most of my communication occurred with . . . It was of a personal nature with both Kaaree . . . I was brought down there another time, and also with the Blue Avians. It was more of a personal communication.

David: Okay. And from what I recall, it was after your visit with the Inner Earth in particular that harassment started to take place on a higher level.

Corey: Yeah. That and after I was starting to put forth information about there being a partial disclosure narrative that was coming and that some of the lower-level Secret Space Program had broken away from the Alliance and were now going to be a part of this program that was going to eventually going to be revealed to the public of the lower Secret Space Program. And I was speaking out . . .

David: I thought the lower Space Program was not a part of the SSP Alliance.

Corey: No, they had representatives.

David: Oh, they did

Corey: Yeah.

David: Okay.

Corey: Yeah. Not all of the different programs that . . . like DIA, all these different groups. Not all of them knew what was going on. There was a select few in the group. And they were breaking away while working inside their group, unbeknownst to the people they were working with.

David: So when did the first Chinook helicopter fly over your house? I think that was around this time too, wasn't it, like November of 2015, something like that? I think it was.

Corey: You know, it was November, December. The Chinook, yeah . . . I came out and I kept hearing this thwop, thwop, thwop noise. And I look out my window and the place that we're staying, the swimming pool, the water was just kind of all vibrating. And I walked out the door, and I look up, and there's a Chinook helicopter directly over my house with a guy.

I see a helmet looking out the side of a service window. And I couldn't believe it. I ran back in the house. I grabbed my phone, came out, was trying to get it all going. And they saw me get my phone ready, and they started to take off. And I caught it on video.

And I started videoing right as they were lifting off, turning, and then they did about three more revolutions of my house after that.

David: Are you near a military base? How far away were you from the nearest military base?

Corey: Well, the formal Carswell Air Force Base is in Fort Worth. It's about an hour away. But they . . . Very seldom are helicopters housed there.

David: And that's where you went as a kid?

Corey: Right.

David: Yeah.

Corey: And then we have Fort Hood, which is more like five or six hours away. And they have a large contingent of helicopters there.

David: Okay. You also mentioned something to me that was so sensitive that up until recently, you did not want to talk to anybody about this or disclose it publicly. But now you've given me the go-ahead to do so and that is that, I don't know if it was this time or another time that one of these helicopters came overhead, that as it's flying around, you're seeing what on your chest?

Corey: No. That was something different. I went outside with my son, and we were walking around in the backyard because he wanted to go outside. And I'm looking down at him, and I see something right here. [**Corey** points to his chest area.] And I look and it is a green laser dot on my chest. And I was out there with my son. So it was pretty upsetting. I nonchalantly put my hand on the back of his head and guided him back towards the door and said, "We're going inside." He didn't . . . He just got out. He was wanting to play. He didn't want to go inside. I was like, "We've got to go inside."

And I didn't tell my wife about it, because she's been dealing with a lot of emotional depression and stuff because of a lot of this stuff.

David: Now, you also described seeing suspicious activity outside your house, people walking around in black clothes, cars that were parked in the road, and then you'd look at them and they'd zoom off.

Corey: Yes. I was walking through the house. I keep weird hours. It was real early in the morning. And I look out and out by the stop sign and street sign, there's a guy all in black standing there holding something in his hand - I don't know what it was – looking at my house, just looking around.

So I don't know if it was some sort of operative or a thief casing the neighborhood, but it got my attention with everything else going on.

David: Now, also sometime during this period of the winter of 2015, you called me up and told me that an anomalous object appeared in your kitchen.

Corey: Yeah. We come and there's a Marlboro cigarette. It's just sitting out on our table. And that's been used as a warning in the past that people come in and they put a cigarette.

David: And you mentioned the Mafia, that this is like a Mafia or has been a Mafia-type of thing.

Corey: Yeah, a syndicate kind of thing. Yeah. To where . . . It's one of many ways that they'll send small warnings and let you know they can get in your house.

David: And is it like a message that you could be “smoked”, quote, unquote?

Corey: Pretty much. Yeah. Also, threats . . . It comes as threats of burning your house down. We can get in your house any time. We were in, you didn't know – to make you feel totally disempowered that at any moment someone could pop out and take you out or burn your house down when you're asleep.

David: Now, right in the middle of all this going on, Gonzales is seeming to be telling you that they wanted to fast track this partial disclosure, right? This isn't something that's going to take a long, long time.

Corey: Right.

David: They're potentially getting ready to make a big move.

Corey: Right. That was the biggest part of the negotiations between the Earth Alliance and the Cabal groups. They were hashing out how they were going to do a disclosure, if they did end up coming together with a common goal. And how much they would release, how they would release it, and they had a whole plan laid out. Well, they had several plans laid out for a partial disclosure.

And one of them was the disclosure of the lower Secret Space Programs.

David: Some people watching this show are going to have trouble understanding why would the Cabal want to disclose anything for any reason at any time?

Corey: They don't have a choice at this point. They are on their way out. They have had - the Cabal groups - have had people defect, bringing extremely sensitive information with them over to the Alliance. They are at a point to where they're just trying to negotiate from a point of weakness while feigning power.

David: What's the next noteworthy thing that takes place with any of this stuff that we've been talking about, Gonzales, the beings, the Anshar, etc.?

Corey: Well, I was still having these etheric conference calls. And the rest of them . . . Kaaree would be in one of these egg-shaped chairs and so would Gonzales.

David: Really?

Corey: Yeah. They would both be sitting . . .

David: In 'the Construct'?

Corey: In 'the Construct'. And we would have meetings that way. Gonzales started behaving very strangely. He was making real smart comments, derogatory comments. And his attitude was just horrible towards me. And it seemed to happen overnight. And I did not know why. And I was given no explanation as to why he had been residing with the Anshar for a number of weeks.

David: So you found this out in the course of these meetings that they had with you?

Corey: Correct.

David: Other than him being snide, what was the content of these meetings? What was actually being discussed?

Corey: There was a discussion of upcoming meetings that we would be having. And Gonzales was delivering messages from the SSP Alliance and confabbing with me about the data that he was giving me. And he was giving me some partial briefings. They seemed to be a lot . . . There was a lot less beef in the briefings than there used to be.

So I felt . . . I could tell that he was trying to squeeze me out.

David: So by this point, you have also apparently been pulled in by this lower level SSP group, but we haven't actually discussed that yet. And I know that you're reticent to want to talk about it because it was very upsetting.

Corey: This was different than anything else I'd ever experienced. My first memory of what was happening is I was walking . . . and there was a parking lot behind my house for a stadium. And I was walking barefoot with people around me, military people around me, walking towards a craft that was parked in this parking lot.

David: I don't understand. Did people come to the door, knock on your door and say come with us?

Corey: I don't know.

David: You don't remember?

Corey: All I remember is walking up towards the stairs to go up onto the craft, seeing a partial view of the front of the craft. It reminded me of these stealth boats or ships that the Navy has a little bit – how it

was angled. I remember walking up to the stairs. I don't remember going up the stairs.

And then the next thing I know, I'm sitting in a fold-down chair inside a craft, and I'm strapped in with a harness.



David: Okay, now the first image that we have is just of the room itself. We have these bunk beds over on the left.

Corey: That fold up against the wall.

David: Right. And there's what looks like IVs of some kind on them. Then we have these chairs that look like flight chairs with seat belts on them.

Corey: Right.

David: So could you describe for us what this image is that we're seeing right now?

Corey: This was the small area of the craft where they interrogated me. And it was a bit tighter spaces than the image shows. It's a little bit spread out. It was a little bit more cramped. But, yeah, the bed. They had IV posts that folded on the side of the bed. And they popped one of those up and stuck an IV in my hand.



David: Now, we have another image here in which now we're seeing you strapped into the chair. And there is a military man standing in front of you, holding out what looks like an iPad in his hand, and you're looking at the iPad.

Corey: Right.

David: So could you explain for us what this image is describing that happened to you during this meeting?

Corey: This group . . . There were two that were working on me.

David: Two soldiers?

Corey: Two . . . And they smelled of Air Force. It just felt like that branch or they came from that branch.

David: Okay.

Corey: There were two that were working on me and one that was coming and going. And he would come in and ask them questions. And they were in the process of taking hair samples. They were scraping skin. They took blood. And they were saying that, “If he’s been where he said he’s been, there’ll be trace evidence, and we can tell.”

David: So they actually know how to measure these off-planet locations by trace elements that would appear in your hair and blood and skin scrapings?

Corey: That’s what they said.

David: Interesting.



Corey: One of them began telling me, “You know that all of these beings are not really aliens. They're just us from the future from two different timelines.” And I couldn't really respond. And he was saying that the Nordic type of people are us from the future. And these little grey beings are us from a different timeline in the future.

And they are coming back to try to fight over the timelines. And they were stating that the Greys, their genetics had broken down so badly in the future that they were coming back to get genetic stock as well.

David: So they've been trying to push this on us for a long time.

Corey: Right. Yeah. This . . . You know, and I really couldn't respond in the state I was in. And with the iPad, I did not recall this immediately, I did not recall this part until later.

The guy that was holding the iPad in front of me first sat there and he started going through all of these different like Scandinavian, German, and all these different phrases for different programs. They were going to see if I was going to be triggered.

David: As in like MKUltra mind control stuff, trigger words?

Corey: Yeah. Yeah. And also tones, like a series of tones or a series of words . . .

David: Really?

Corey: . . . in different languages. And they went down a whole list. And all of that I was able to recall.

David: So nothing caused you to go into some mind control state?

Corey: No.

David: Yeah.

Corey: So what occurred next . . .

David: What did they feel when they . . . What were they looking for by running these words on you?

Corey: Well, they were looking to see if I was triggered. They were already a little . . . Their eyebrows were raised a little bit already when they strapped me in and before they drugged me, they were starting

to power up the craft to take off. And I didn't normally hear this in other craft. I heard like rotors starting to turn all around me, but I couldn't see them. And they felt like they were under. And the craft started to vibrate a little bit.

Then I heard that distinctive sound of when a capacitor is charging or discharging. And I felt when we started to leave, I felt a little inertia, which I normally don't feel. And I made a comment to them that this must be one of the older models because I'm not used to these sounds and sensations.

And they just kind of looked at each other kind of puzzled.

Well, we're skipping ahead a little bit with the iPad because I hadn't recalled what had happened. But they put an iPad in front of me that had a little camera on it somewhere that was watching my eye. And I was drugged. And I was hanging down and my head was like this. [Corey's moves his head so he's looking down at his stomach.]

And they held it under . . . Like hovering above my lap, they held this iPad kind of machine. And they started going through all these photographs, six photographs per screen – three on top, three on bottom – and they looked like academy photos – military academy photos.

David: When people graduate and they've got the full uniform on, and they got the flag behind them. That kind of thing?

Corey: Yeah. The flag's behind them, different symbols behind them or seals for branches of military. And then there were people that were in suits as well as they were going through.

And I was looking at it. And as they would go through, they would pause for a second. If I looked at one of them and recognized one of the pictures, it highlighted red. And this occurred three times. There were three people that I recognized out of all of the photos. And it turns out one of them was Gonzales.

David: Wow!

Corey: Yeah.

David: Now, when you say that some of these people were wearing suits, why would they not be wearing military uniforms?

Corey: I don't know. They could be contractors. I have no idea.

David: Intel people perhaps?

Corey: Yeah, or . . . Yeah, intel people, politicians. I have no idea who the people in suits were. And they had flags as well.

David: But you didn't remember outing Gonzales until much later?

Corey: Right. Because I did not understand why he was being so hostile towards me in our meetings. He was being very rude.

David: Now, you also said in the course of this interrogation that they kept telling you, "You will forget. You will forget."

Corey: Right. Well, one of the people, the guy that kept coming in and asking questions, they were like, "Are you sure he won't remember this?" And the person that had the laptop was like, "There's no way. It's like class something amnesiac" or something. He said that it's like an anesthetic when you go to surgery.

David: But somehow you, maybe because of the same powers that allowed you to not be blank slated after your space program service, this actually did not work on you.

Corey: The data came back a little differently. It came back in chunks. And then I had to marry them together. And once I put the unsegmented memories together, then it just all started tickling down and opening up for me – all the memories.

But I did not remember the outing of Gonzales and two others until the Anshar actually told me in a meeting after Gonzales had worn out his welcome in the Anshar city he was staying.

David: These guys . . . Did they think you were a fake or were there things that were shocking to them?

Corey: Well, they didn't understand because the information I had been giving was accurate. And they didn't understand how I could be giving accurate information when according to their records, there were no records about me in all of these program files that they were looking through.

So I think they were trying to investigate and find out more.

David: Do you think these guys were aware of compartmentalization and the higher-level Secret Space Program, or did they think they were it?

Corey: They thought they were it. But they were aware of compartmentalization. But their egos had been played too. They'd been told, "You're at the top of the totem pole. This is all there is."

David: So you have this interrogation. And now let's go back to the meetings in "The Construct" with Gonzales and Kaaree. You said you identified three people, but you didn't know that anything had changed.

Corey: Right.

David: However, and I remember talking to you about this, it was of deep concern to us because your briefings used to be quite thorough and now they've gotten almost down to a trickle.

Corey: Yeah, very sparse in data.

David: And Gonzales . . . His whole attitude and demeanor towards you changes.

Corey: Right. Yeah. He was just making snide comments, little rude jabs, and I didn't know how to respond because it was totally out of character for him. He normally was the one pushing to get more intel to me instead of holding back information.

David: What did Gonzales say during this time about the war for Full Disclosure vs. partial disclosure? Because I know some of that was starting to come out.

Corey: Well, yeah, our conversations all throughout were dealing with partial disclosure, their ideas on how I should proceed to get people together and to focus and that kind of thing.

David: Right. Did Gonzales say that there was still a possibility of Full Disclosure, or was it like partial disclosure was now going to take over?

Corey: The Alliance believed that partial disclosure would be very difficult to do with all of the data that was out there.

David: Because they'd have to fly in the face of all these high-quality whistleblowers who are already on public record.

Corey: Right. And people would start asking all kinds of questions.

David: and then it just unravels.

Corey: Right. Kaaree had stated that he was behaving very erratically. He was constantly pacing off steps and making mental notes, like he was doing intelligence-type gathering.

David: Like he's trying to create a map in his head of the base that he's in?

Corey: Right. Yeah. You normally count paces.

David: Okay.

Corey: And this store had so many paces down this corridor. That kind of thing.

David: And, of course, these people are telepathic so they know exactly what he's doing. You can't hide anything.

Corey: Right. And apparently he was also going into restricted areas, wandering into restricted areas when he knew better.

David: Wow! But did you know why he was in the Inner Earth at this point?

Corey: No, I had no idea until he had already left and went back to a Kuiper base. And Kaaree had one of those, I guess, etheric conference calls with me and had explained that Gonzales was not staying with them anymore, told me a little bit about how he had worn out his welcome, and then that's when she opened my eyes to . . . that I had outed him and two others.

David: Okay. I got to ask you this because a lot of people are going to be writing in these comments otherwise. Why in the hell, if the Blue Avians can pull you out of Mars when you're about to be killed on the Mars base . . . We did that episode already. Everybody's seen that. Why in the hell do they authorize you to get pulled in?

And if Gonzales ends up getting angry at you about outing him, how could you have defended against this technology? I mean, you're drugged. You got abducted. You don't remember how it happened.

Why would this be authorized? What was going on here?

Corey: Well, they later on, it was explained to me by the Blue Avians that these incidents needed to occur.

David: Oh, really?

Corey: Right. That it was . . . That they were all catalysts for other things to happen.

David: Let's talk a little bit about what Gonzales' role was. How critical was his role to the SSP Alliance?

Corey: Well, he was living down here on the Earth a good deal of the time under a cover life. And while he was here, he was interfacing with some of the Earth Alliance and some of their operatives that are down here.

And when he was very quickly removed, basically rescued by the Anshar, he was unable to fulfill those duties anymore.

David: Would you say that these lower level SSP people that abducted you were reporting back to the Cabal?

Corey: I assume that. But I don't know if that was an unauthorized series of missions they did trying to figure things out, get some intel themselves.

David: Why do you think these . . . If the lower level SSP people are not connected to the Cabal, why would they want to take Gonzales out? What would be the objective that he would have to be rescued by the Anshar?

Corey: Well, out of the three people, one of them was killed. And one of them disappeared.

David: The three people that you outed?

Corey: Right. And Gonzales was rescued.

David: So let's just say if the lower level SSP people did report to the Cabal, the Cabal knows who everybody is in the Space Program. They have dossiers on everybody, but they don't necessarily know who's in the Alliance.

Corey: Right.

David: Now, you did say the Alliance has some safety zones in the Kuiper Belt, and there are people hiding out in there. But there's obviously also double agents – people that are still working in the program - but they're keeping a very, very tight secrecy around themselves to be able to pull this off.

Corey: Correct. And very soon after that . . . after this conversation with Kaaree, I was actually teleported, as I was before, just flashed down to one of their flight control areas. And I was told that I was going to be taken to a meeting in the Kuiper Belt because the SSP Alliance at this point, they've been unable to enter the atmosphere or low Earth orbit - near Earth orbit.

David: And why not?

Corey: Well, they no longer had clearance.

David: From who?

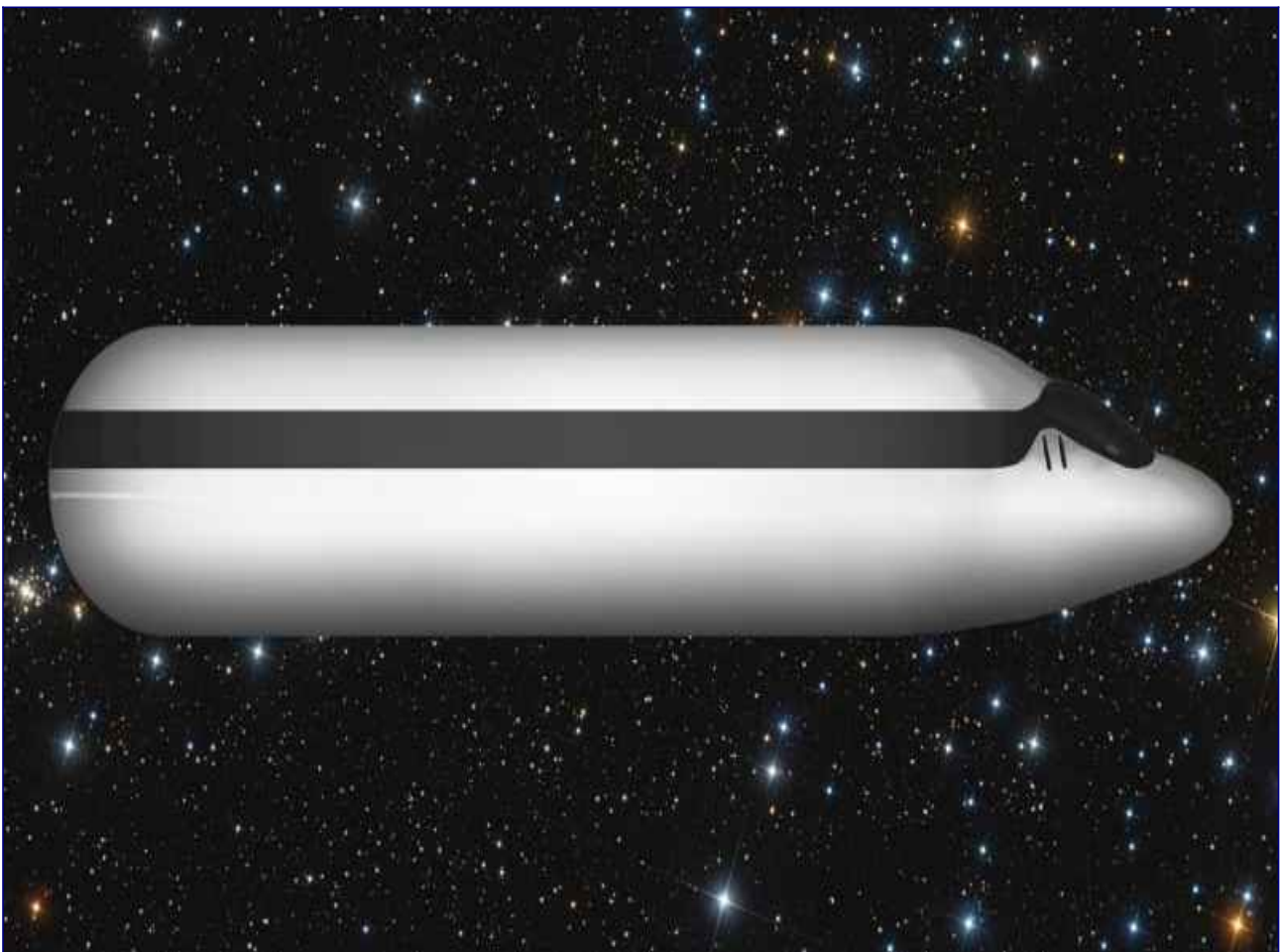

(Gaia used an incorrect image. This is the correct image of the Anshar Bus craft)

Corey: From the people that are basically like air traffic controllers at the LOC, and those who control the defense grid around the planet.

David: Why would they lose clearance?

Corey: Well, because they had been outed as opponents.

David: Okay. Right. So they had been working within the system, but keeping this all very secret.

Corey: At that point . . . Until that point, they could put a call in through into intelligence assets, task intelligence assets, and those intelligence assets would have no idea that they were doing errands for the SSP Alliance.

David: Wow!



Corey: But when I was pulled down to the Anshar flight control area, I saw one of the craft that Gonzales had told me . . . that he called “a bus”. He called it an Anshar bus. And it was kind of like a

bus. It had a bunch of . . . you know, a whole lot of seats, like 26 or 28 seats in it. And it was arranged sort of like a bus. And the front of it squared off and went into a cone like a fighter craft.

And there were two Anshar pilots that sat one in front of the other in the cockpit area. And it was just Kaaree and I. And I expected her to sit next to me, but she sat kind of in another seat, one seat up across.

David: Okay.

Corey: And they took me to the Kuiper Belt. And this was going to be the first time I saw Gonzales since I knew that he had been outed. So I was a little bit nervous.

So we get to the Kuiper Belt base - the same one where earlier they had the Anshar meeting the Triangle-Headed being, the Golden Triangle-Headed being.

David: Okay.

Corey: So I recognized the area. But this time I was brought into an interview room, basically an interrogation room with a metal table that was welded or bolted to the floor. And Gonzales was sitting in a chair. And there was a guy, kind of a big guy, sitting in a chair right next to him, which . . . The whole thing was unusual.

And I was sat down and Gonzales wouldn't hardly even look me in the eye. He just had this total energy of disgust towards me. And that threw me off. And then this other guy started talking. He was talking more than Gonzales.

And I was supposed to get some sort of a briefing. And they were sitting there sliding a pad back and forth, a smart-glass pad, back and forth. And the other guy actually had a pen and pad of paper – real low tech. He was writing stuff down.

He had notes on there he kept sliding over to Gonzales and pointing like this. And Gonzales would do that. [Gonzales would shake his head side-to-side meaning 'no'.] And Gonzales was obviously on board now with restricting information to me since I had been a major security leak in that interrogation when I revealed three people.

So that meeting was real short – not so sweet.

David: Did you get any briefing information at all, and if so, what did they actually tell you in this meeting?

Corey: They were just giving me very light information. Different . . . I mean, Trump came up. They talked about how there were some certain threats against him that weren't being taken seriously. They were talking about a bunch of . . .

David: You mentioned the possibility that he could be assassinated by what would appear to be a Mexican national.

Corey: That's what their report said.

David: But that it would actually be a Cabal operation . . .

Corey: Right.

David: . . . and that his people weren't taking it seriously enough.

Corey: Right. And so they were talking about some of the meetings that they . . .

David: Now, some people are going to go, “Whoa, whoa, hold on. Trump? Why do they care about Trump? What's their opinion on Trump?”

Corey: Well, they care about Trump and Sanders big time. They've been extremely excited about the movement behind both of them – people standing up to the-powers-that-be saying, “Enough corruption, enough lies”.

David: So they don't think Trump is, with all his money, that he's Cabal?

Corey: Correct.

David: They think he's actually totally different from that.

Corey: Right. Yeah. And they were not pushing him over Sanders or Sanders . . . They were just very happy about the movement.

David: I have had other insiders independently tell me that the Cabal feels that if Trump wins that it would be catastrophic for them.

Corey: I was told that there is no way they're going to let him win. They'll steal the election - whatever they have to do.

David: Wow!

Corey: And this was just one thing. I mean, they also . . . Next, they covered . . . They expected some very big terrorist attacks, like a last hurrah of ISIS, because most of the operatives had moved out of Syria and into Europe and were trying to get to the United States. Because . . .

David: But we know that ISIS has gotten heavily defeated and they were . . .

Corey: The point is Gonzales was making it very obvious that he felt differently and that I would now get very manicured intel.

David: Right.

Corey: That they were making . . . It was almost like theater. They were making a point that I had screwed up, even though I didn't do it on my own volition, that I had screwed up and it had cost them dearly. And it did.

David: And what was the attitude of pen and paper guy? How did he treat you?

Corey: He was kind of gruff, but he didn't . . . I mean, there wasn't a whole lot of interaction. You know, he was just kind of a gruff military type – matter of fact.

David: What takes place next?

Corey: I was extremely upset on the way back.

David: In the bus craft?

Corey: Yeah. And she was asking me what all occurred telepathically.

David: Okay.

Corey: And I had just enough time to relate to her what went on in the meeting when we were approaching Earth. And then we went back down, entered through this blue swirl in the ocean, and ended back up in the flight control center. And I was sent back home.

David: Okay. And the blue swirl is just like a portal thing . . .

Corey: I would imagine.

David: . . . that appeared in the ocean. Okay. Now, this is also going to help to set up and get people excited about what we're going to talk about in the next update episode, because some very, very fascinating stuff takes place regarding Venus, Ancient Builder Race outposts, whether there's Inner Earth beings living on Venus.

So since we don't have enough time to do this in this episode, but could you just give us a teaser about what we're going to be hearing next – some of the really weird stuff that happens?

Corey: Yes. And when Gonzales was still staying with the Anshar for that number of weeks, the Anshar had arranged a meeting on this outpost on Venus that had working Ancient Builder technology. And there was another meeting planned as well. And Gonzales found a way to convince them to only take him.

David: Right. All right. So that's just some of the amazing stuff that we're going to be getting into in the next episode of these updates. It's pretty fascinating stuff that gets very strange. And also, we have what starts to happen with you and this guy we're calling “The Wrangler”, which I know I've been trying to kind of hold you back from having to talk about this because it's pretty frickin' horrible for you.

Corey: And the Wrangler happened to be the gruff guy that was sitting next to Gonzales.

David: Okay. So that pen and paper guy is the Wrangler.

Corey: Yeah.

David: Okay. So there's some pretty intense stuff coming up for you in the next episode. This is [Cosmic Disclosure](#). I'm your host [David Wilcock](#). And I thank you for watching.

Cosmic Disclosure: From Venus to Antarctica

Season 5, Episode 8

David Wilcock: All right. Welcome back to “Cosmic Disclosure”. I'm your host, **David Wilcock**. And I'm here with **Corey Goode**.

I'm actually learning a lot myself by talking to him about this, because even though we discuss some of these things on the phone, I've never really gotten to see it all laid out like this. It is a tragic story.

In fact, I would say this is probably the greatest drama of any of **Corey's** accounts that we've had since he was first taken to Mars and was captured and almost killed before he got portaled out.

So **Corey**, welcome back to the program.

Corey Goode: Thank you.

David: So where we last left you, you have now been in the bus with Kaaree on the way back from this meeting in the Kuiper Belt in which this man who becomes The Wrangler later on in our story and Gonzales were both sitting there. And they're looking at intel, but they don't want to tell you anything, which means you and I, and, thus, our audience and everybody else, is getting cut off from valuable stuff.

And everything we've been hearing is that this is all building up to some epic defeats of the Cabal on Earth, some stuff that we want to know more about.

Corey: Right.

David: So did you get any sense of the progress towards the exposure and defeat of the Cabal from any of these briefings at all?

Corey: It sounded as though everything was still status quo on the negotiation side, but there was beginning to come . . . Information about Antarctica was starting to come out. And there was a little bit of that in there, but that really developed more later.

David: The Wrangler and Gonzales started to give you information about Antarctica?

Corey: Right, that . . . Well, Antarctica and more information about . . . That was actually the time I was given information about bases, the underground bases in Brazil and Argentina, that Cabal groups were going into like ants, bringing supplies and all kinds of stuff.

And I was told about the rift system that ran from Antarctica and connected to enough . . . another rift system that ran underneath South America, Central America, on up to the United States. And part of . . .

David: These rifts are in the ocean, and they're like traversable tunnels with water in them?

Corey: These are actual tectonic rifts that, you know, like a rift, and . . .

David: A crack between the plates of the Earth.

Corey: Right. And some of the area was completely underwater. In some areas, they had built out towards the top little bases or outposts. But the area was so incredibly huge.

And they described what they call 'black subs' that were the size of container ships that carried shipping containers full of beans, bullets – everything needed. And they were traveling underwater, propelled electromagnetically underwater, through this rift system all the way to Antarctica where they had a port.

David: All right. I want to bring this to your attention, **Corey**, because I don't know if I've ever said this to you. My insider, Bruce, who I met through Hoagland, who's a major part of the new book "Ascension Mysteries", told me that he may be leaving, that he may have to go to Argentina or somewhere in South America.

And when I asked him why – now remember, this is the guy who worked for the Reagans – he told me that they are moving everything out of North America, Europe, all that. They're migrating down there. And it's because there is this massive effort against them from Putin – is how he was explaining it.

Then we independently had **Pete** Peterson basically tell me the same thing, not that he was going to be leaving, but that there is a massive transportation of all kinds of assets, personnel, personal items from high level Cabal people.

They're moving their houses, their families, their staff, everybody. They're trying to hide out. Now why do you think, or were you told, why are they hiding out?

Corey: Well, because of the way things were going for them, was what I was told at this meeting. But later on, I was told that they, at least some of them that were headed down to Antarctica, had the belief that there was going to be some sort of solar kill shot or huge plasma waves that were going to hit the Earth.

And since they couldn't escape the Earth at the time, they were going to hide out under the ice shelf.

David: And this gets back to the Hindu Zoroastrian Christian prophecy of the so-called glory Lord of this big solar flash event.

Corey: Correct.

David: Okay. So, but can you also corroborate the intel that I got from Bruce and Peterson that these people feel like there's going to be some epic public defeat of them, exposure of them, and that's part of why they're on the run?

Corey: Oh, yeah. They're . . . This is the part of the Cabal that is not negotiating. Part of . . . There's part of the Cabal that's negotiating with the Earth Alliance, and then there's another part that is not up for negotiation. Don't even consider it.

David: Okay. So let's now move forward on this. And what is the next noteworthy thing that happens? Did you talk to Kaaree and find out more about what Gonzales was up to while he was in the Inner Earth?

Corey: Yes. And that had occurred a little earlier. The conversations I was having with Kaaree were after she had told me that Gonzales was not only made things to where only he went to this outpost, this Ancient Builder Race outpost that was working, operational - he had them take only him to that and also to another meeting right after, which was very similar.

It was the exact same station that we had gone to outside of . . . in Jupiter's orbit. He had, after that, he had been taken directly out to Saturn, which had an exact duplicate base or station that we had gone to around Jupiter that we had meetings with the Super Federation group.

This . . . But when he went to this, it was the same thing. He went through this, not really a portal, but some sort of a time anomaly to where you have to go in and come out the same way. He went . . . They went in the same way. They docked. There were no other vessels. There was nobody in that station at all.

And she took him to the exact meeting room that we had been in where everyone would sit in these horseshoe shaped areas where they were assigned. And he saw one of these beings again that was out at the Venus location.

And once again, he was told that he lacked humility. And he couldn't go ahead with the meeting.

David: So I want to double click on Venus a little bit here, because I have had an incredibly hard time getting any information about any unusual activity going on in this planet, around this planet, at all.

Corey: It's mostly a no fly zone for various SSP groups.

David: So let me tell you what I have heard from various insiders whose testimony corroborates with yours, and we'll just take it from there.

First of all, I talked to **Pete** Peterson about it, and from his level of need to know, that's a very important point for everybody to remember, 'his level of need to know', he was told that the planet is very hot because of all the clouds and that the only . . . that there are some developments from our Space Program there, but they have to be staffed by androids, because humans can't handle the heat.

That's what he was told, that everything that's there is run by basically robotic humanoids and not people, because the temperature is so sweltering.

Corey: Yeah. Well, we have bases that are floating in the clouds of Venus.

David: 'We' as in the Space Program?

Corey: The Space Program.

David: And you knew that while you were in Solar Warden?

Corey: Yes. I had read about those facilities.

David: Okay. Could you tell us a little bit about what they are? What they did?

Corey: Well, they were research. They were listed as research facilities that were somehow suspended in the clouds of Venus and that there were also some on the ground that were built pretty much just like the high pressure underwater bases.

Would you like to hear what Gonzales said . . . reported that he saw?

David: Yeah. Yeah.

Corey: Him and the Anshar bus craft and Kaaree . . .

David: Now when did he report this to you, first of all? Or did you get this from Kaaree?

Corey: They both reported it to me when they were both sitting in the . . .

David: In the Construct?

Corey: In the Construct.

David: All right. So what did Gonzales tell you in the Construct happened to him?

Corey: He stated that they entered Venus' atmosphere and . . .

David: Was he in the Anshar bus craft?

Corey: Yes.

David: Okay.

Corey: They entered the Venus atmosphere, and when they got down to the area where the clouds broke, and all of a sudden these holograms just sort of phew, phew, over these different areas. And there were these . . .

David: I don't know what you mean by 'phew, phew'.

Corey: Well, they just . . . They turned off.

David: The holograms turned off.

Corey: Yeah, hologram, like camouflage holograms that were covering . . .

David: So what you're seeing without the holograms . . . with the holograms in place (it) just looks like a regular, ordinary, barren planet surface?

Corey: Just geology.

David: Okay.

Corey: He could see these very large, very large H-shaped buildings, and flew down, went down into the ground of Venus and traveled a little ways before they landed in a cavern. And this one that he went to was a working outpost. So . . .

David: For who?

Corey: For the Ancient Builder Race. This was Ancient Builder technology.

David: So the Ancient Builder Race did not leave.

Corey: Well, the technology was still working.

David: Wow!

Corey: Yes. Once they had landed and disembarked from the craft, he was told to wait at the entrance – not to come in. And Kaaree and two others, probably the pilots, walked in to this arch area that he could just see a piece of kind of an angled glass-like structure going up. And he couldn't make out the rest of the structure.

And they walked inside . . .

David: And it was of colossal size?

Corey: Colossal size.

David: Wow!

Corey: So Gonzales is waiting in the area where they had landed, but watching. And they walked in, and all of a sudden the . . . everything lit up. The glass got darker, and then started to have all these symbols appearing, all going all the way up the . . . It's like an A-frame, I guess, going up like this. And

all these symbols started appearing.

And one that he could make out he said looked like a backwards E that had a little G thing on the bottom.

David: Hmm.

Corey: A symbol he had never seen before. And that's the one that really stuck in his head. The rest were real small, and they would just - 'phit, phit' – appear and disappear, just all up and down this thing.

David: Now, how does this match up with other cool stuff that Gonzales has seen? He's obviously been to a variety of star systems. He's seen all kinds of extraterrestrial constructs.

Corey: This was a big deal.

David: Was he blown away by this?

Corey: Yes. No one had heard of any working Ancient Builder Race technology, or any that was not just destroyed or had been visited and picked at. Scavenged.

David: But this seems to have been protected by holograms, and very much active. It hadn't been smashed by meteors. It was still working just fine.

Corey: Correct.

David: So he's blown away. He's tripping out from this.

Corey: Yeah. He was very excited.

David: But you were supposed to be there with him, weren't you?

Corey: Correct.

David: But he is now playing this dodgy game and didn't invite you.

Corey: Right.

David: So what happens next? He sees all these symbols on the wall.

Corey: He saw . . . You know, the three Anshar came back, and Kaaree said that they refused to . . . and he could see the being that they were conversing with.

David: And what did that look like?

Corey: It was a 12 to 14 foot tall completely white being, white clothes. And that's from that distance. That's . . . you know, he said that its . . . It had a head that had a very interesting nose that came down that reminded him of the Easter Island heads.

David: Oh, like the Moai.

Corey: Yeah. It was kind of similar. Not exactly.

David: Hmm.

Corey: So he was pretty excited. And then the Anshar walked up, and Kaaree told him that he would not be entering the facility or the outpost because the guardian of the outpost had told him that . . . or they called him a sentinel.

The sentinel had said that Gonzales lacked humility.

David: Okay. I think a lot of people may be confused at this point, because you told us before that the Ancient Builder Race folks are long gone.

Corey: Mhmm.

David: They left behind a whole bunch of ruins, including these little tablets that can create stasis fields where you hopscotch through 10,000 years.

Now you're saying that there is a being that looks like Easter Island that's 12 feet tall that's still there hanging out for two billion years?

Corey: Yes, but it seemed to have been materialized or projected from this outpost.

David: Right. Like the same thing with the holographic projections of clouds, and then these projections of symbols.

Corey: Right.

David: So this may not have been a living being . . .

Corey: Yeah, it was not . . .

David: . . . as much as some sort of . . .

Corey: . . . a flesh and blood living . .

David: . . . super high tech repository of . . .

Corey: Projection.

David: Wow!

Corey: So after that, they left. And he again had talked his way, and I talked about what had happened around Saturn. And that was a real short non-meeting, because he was told again he lacked humility and was turned away.

David: This would have been a meeting with the Super Federation and it took place in the same room?

Corey: No. This was a totally different station that was an exact duplicate of the station that the Super Federation was meeting on. But this one was not . . . The second one was outside of Saturn, not Jupiter.

David: Oh. You were supposed to be there with him, and he had outfoxed you somehow.

Corey: Yes. And at that location, they asked to meet with the name that they call me.

David: Okay. Now, . . . and I know you can't say what that is, and I respect that. The Blue Avians have only ever spoken to the SSP Alliance through you . . .

Corey: And Gonzales.

David: And through Gonzales. Now he's cutting you out of the deal. But did the Blue Avians tell him to cut you out of the deal, or did he just make this decision on his own?

Corey: That was his own. He was in a reactionary state.

David: Sure. So both of these meetings get blown, and they don't happen. Let's go to the next part of the story. What happens at this point?

Corey: He is taken back to the Anshar city. And it was very shortly after that that he had officially worn out his welcome and was sent back to the Kuiper belt base.

And that's where he's remained as . . . until he . . . I was told that he went off for healing with the Mayan group.

David: And that's interesting, because I remember back when you were still on good terms with him that he had warned you at one point that you might not see him much longer.

Corey: The way he stated it was if he were to disappear and no longer . . . and didn't have a chance to say goodbye, that I should understand that he has gone . . . It was his turn to go in with the Mayan group for healing - the healing technology they have.

David: It's really kind of sad that this ended up happening the way that it did. You and Gonzales were good buddies, and now he's basically trying to stab you in the back. And I think a lot of people watching this show, they might want to have had a very benevolent view of Gonzales. They've seen him as a hero. They like him.

Corey: I like him. I mean, he was . . . He's just in a triggered state. He's, you know, upset.

David: Did he have . . . I don't know if you can say this, but I guess since he's outed now and they know who he is, I mean, did he have family here on Earth? Did he have to . . . Did he, like, lose people?

Corey: He told me that he didn't have family, but later on he said that there were people he cared about that he was worried about.

David: Hmm.

Corey: But he was not going to give me any specifics about people close to him.

David: But you said that he had this very important job liaising with the Earth Alliance, and that he was of critical importance in this whole SSP Alliance plan to try to get Full Disclosure on Earth.

Corey: Yes.

David: So he himself apparently just couldn't forgive you for what had happened here.

Corey: Yeah, he . . . One of his friends and colleagues was dead, and another one was missing, and he was outed and could no longer perform his job.

David: We've also heard from you before that there has been a breakdown in communication between the SSP Alliance and the Earth. And you mentioned in the previous episode something really fascinating which I hadn't understood until we were doing this on camera, that the SSP Alliance couldn't just show up on Earth whenever they wanted, that they had to do all of this stuff they were doing covertly.

Corey: Yes. Some of it was done covertly, but they were doing a lot of it overtly. They were getting clearance to land at the LOC (Lunar Operations Command). You can't just land at the LOC and disembark a bunch of people and go into a meeting room.

David: Right.

Corey: So, they . . . Until they were outed, they had a lot more, I guess, ability to move around.

David: So what do you . . .

Corey: And during this time, the Anshar were really working on trying to get a meeting with the Super Federation, the Draco, and other groups that had signed this what they called that Muhammad Accord that would allow them to interact with humans more openly.

All the signatories of this treaty had to agree to change it to ratify it.

David: This involved the evil and the good groups all having to form a treaty with each other?

Corey: All groups present in the solar system that were in competition, had different agendas. They were up until the . . . supposedly up until the time just after Muhammad, they were appearing to people and having open conflict in the skies.

And this treaty stated that they would allow humanity to develop on its own overtly, and they would only covertly manipulate and puppeteer the leaders.

David: Why do you think both the good guys and the bad guys would agree to something like this?

Corey: Well, because they were having major skirmishes. They were chasing each other out of different areas. They were destroying the experiment, the genetic experiments of the others. It was chaos.

David: So this treaty essentially served both sides. It kept the game fair. They both have to work covertly. They can't tell us who they are. Each side gets to take its chance for the title belt, which is the control of the planet and control of humanity.

Corey: Yes. And I . . .

David: And humanity's ascension, whether it goes dark or positive.

Corey: And also, I kind of intuitively picked up or felt that it also involved maybe carving up the planet into territories.

David: I see. So now, let's get to what happens next.

Corey: Next, I had had another series of, I guess, etheric conference calls with Kaaree.

David: In the Construct?

Corey: In the Construct. And in one of them, she told me that I should be ready to go and have the meeting that I was supposed to have on Venus and visit the ancient outpost.

David: Oh!

Corey: And very shortly after that, I'm not sure how many days, I was . . . I went and I laid down in bed. I was just starting to fall asleep and then a flash. And I'm confused. I'm still laying down on some sort of bed kind of thing. And I sit up, and I . . . just the atmosphere felt . . . You're in a different place.

And Kaaree was there. And she said . . .

David: And this is not the Construct now. This is real.

Corey: No. This is real.

David: Okay.

Corey: And she said, "It is time for us to make our way to the outpost."

David: Wow!

Corey: So we boarded a different Anshar bus that had different colored seats. One of them had sky-blue colored seats, and then the one we got in this time had, like, burgundy-ish color seats.

David: Hmm.

Corey: And it was a little bit different that there were two chairs on this side, and then there was, like, a big wraparound kind of couch that went . . . instead of seats being on the other side.

David: How futuristic did it look compared to anything we would build here on Earth?

Corey: It . . . There was nothing that you would look at and say, “That’s an engine compartment. That’s where thrust comes from.”

They had windows that wrapped all the way around the back and came up and then in the squared-off area in the front. And it was . . . Everything was white. And it looked like real thin material. Whatever was between you, the bulkhead, between you and what was outside of the fuselage of the craft, was very thin.

David: Okay. So you just get this flash, and now you’re on board this craft in a bed.

Corey: No. We had to board. We had to leave a room and then walk a little ways into the flight control area and board the craft.

David: Oh. Did the room look consistent with other Inner Earth areas that you’d visited before?

Corey: It was a white room.

David: And you fly through a portal? How do you get out of there?

Corey: Well, we . . . the same way. We fly out through the blue swirl.

David: Okay.

Corey: And we exited the atmosphere, and we headed to Venus. She said, “We were going to Venus to the ancient outpost.” And that was a very short trip in that craft. I don’t even . . . We were talking a little bit, but all of a sudden we were just there in a matter of minutes.

And we stopped pretty far off. You know, Venus was about this big. [**Corey** shows a 10-inch circle with his hands.] And there were all of these real long, several kilometer long craft that were real narrow, almost pencil-looking. And they had faded red, looked like paint, on the back and on the nose cone.

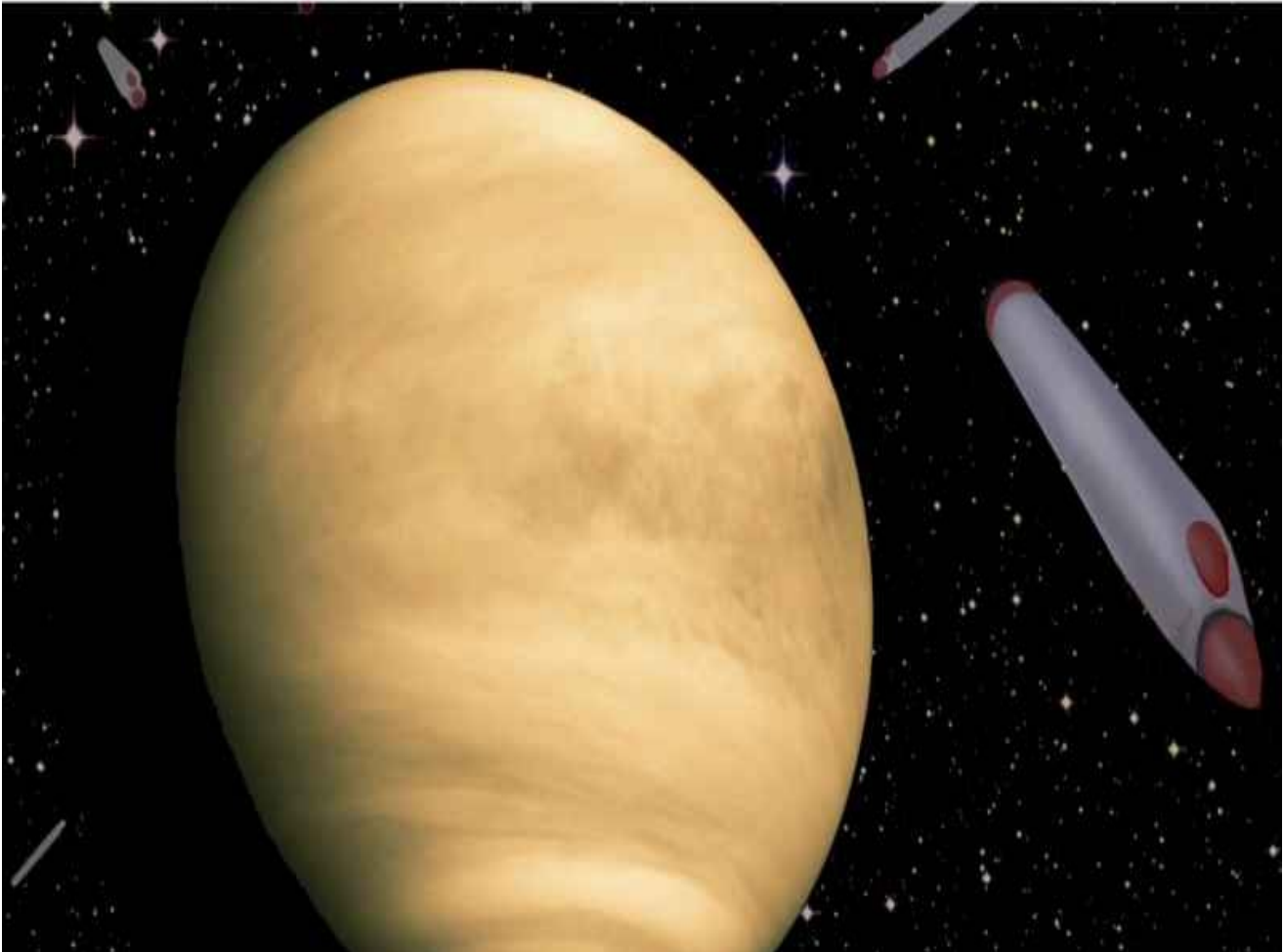

And then there was faded , , , some sort of, I guess, ornamentation, decoration, that had been on it, that I couldn't make out, close to where the cockpit was. And they were pointed down towards Venus with the rear end sticking out, you know, toward space, and were just parked there.

And then there was one of the big craft that just immediately appeared in front of us and blocked our way. And I didn't hear anything, any . . . You know, there was no radio chatter.

David: So you have no idea who these people are . . .

Corey: No.

David: . . . or where they came from.

Corey: And nor was I told.

David: Wow!

Corey: And she said, “We’ll need a few moments. There is . . .” This was, I guess you would call, a scheduling conflict.

David: Ha, ha, ha.

Corey: So we're sitting there, and she starts to go in . . . and we talked a little bit, or conversed a little bit. And then she was . . . started to . . . like she was starting to prepare me for what I was about to hear.

And she also inquired about this . . . if this meeting was approved, when it would occur, the logistics of it - between the Super Federation and all the groups that were signatories to that Muhammad Accord, or whatever they call it.

David: Okay.

Corey: And she was just starting to get into tell me about some of the things that the Draco had claimed. They had claimed that millions and millions of years ago, this was their genetic experiment location, and that some of these groups had come in from other star system and had wiped out their colony here, and that there were something . . . that there were three lost races that they were upset about.

David: You said the Draco only showed up after the Super Earth exploded 375,000 years ago.

Corey: Right. Right. She said this was the narrative that they were putting forth, that the Earth was theirs and it always was.

And she was like really just starting to get into that, and she stopped and said, “We will have to return another time.”

David: What are these three lost races?

Corey: I don't know.

David: Okay.

Corey: I don't know.

David: But they're . . . the Draco are claiming that they made them, or that they started out here? This was their laboratory?

Corey: That they started out here. That's all that I got out of her before, you know, we started to head back. And . . .

David: So you were turned around by these ships.

Corey: Right.

David: You weren't able to proceed with the mission.

Corey: Correct.

David: What's the next noteworthy thing that happens in our story now?

Corey: Well, in the conversation, I had been . . . I was talking about how things were rough between the SSP Alliance and I, and how I had been told that I didn't really have that much to offer them, you know, that I . . . pretty much the only thing I had to offer them is to do odd jobs and to work for them.

She said that will soon change because you're going to accompany us on a reconnaissance flight. And I was like, "Okay." And so we headed back to Earth.

And we flew in the atmosphere, the same area where we punch out and punch in. And we head down at an incredible rate of speed. I could see a land mass area. I didn't know what it was because it was very cloudy, and it was dark.

David: Hmm.

Corey: And we shot down. And then right when we got to the surface of the water, I was thinking we're going to, 'phst', punch through the water. We straighten out parallel with the water and increase speed. And all of a sudden, I start seeing . . . looks like ice cubes all next to each other everywhere, almost like you could walk on them. Tons of ice. And . . .

David: You don't literally mean cubes. Just you're talking like icebergs.

Corey: Right.

David: Yeah.

Corey: But we're passing by it real fast.

David: Okay.

Corey: And she starts telling me, she said, “The technology of this craft is incredibly intuitive.” She said, “Do not get lost in the data.” [**David's** looking at **Corey** with an inquisitive expression.] And, yeah, I had the same look on my face, I'm sure. Ha, ha.

But she said this just before we started heading right towards a giant wall of ice, like a ice shelf. And we were heading directly towards it at speed.

David: Wow!

Corey: And we passed right through what had to be some sort of hologram. And soon as we punched through, we saw an area carved out to where the largest ship that we have could go through and still have two or three times the height of the ship to the ceiling of this archway.

But there was all of this, I guess, steam. It was real foggy.

David: Okay.

Corey: At the entrance, this like fog was coming out. And we headed directly into this basically ice tube. And we were flying all around, and there'd be areas . . . all you'd see was ice, but then you would see, like, some little bit of rock outcroppings. And this was several miles that we went that way until everything started to then spread out and open up.

And then we were flying over water. We're flying under . . . over water, under the ice. And then we came up upon this little island area that had a little outpost – looked like an industrial city, but not a city. It was small.

And we're still going at a good clip. And all of a sudden, we're . . . there's land below us. And you can't

see it real well because it's very dark. And then we get to an area and you start seeing light, a lot of light, up ahead.

And the light was penetrating and refracting and reflecting out of this giant ice dome above the ice.

David: Hmm.

Corey: And there were these pools of water that had steam coming out of them. And it was obviously very warm. I could . . . There were trees that looked about this big [**Corey** shows a distance of about 4 inches with his fingers.] that looked . . . that had pine needles on them. But it was so dark, I couldn't make them out real well.



And we curve around this mountain . . . and there were these mountain peaks that came up out of the ground and disappeared into the ice, the ceiling of the ice. It was bizarre.

And this was obviously . . . this ice pocket, or little igloo under the ice, was obviously created by the thermal activity. And this was in the northwest area of Antarctica.

We then came upon the first really big industrial city that I saw under there. And you could . . . It looked like it was . . . At one time, it was about this size, [**Corey** shows a distance of about 10 inches between his hands.] and then they had built it out [**Corey** spreads his hands as wide as he can.] over time.

But amongst the area that they had built out, there were these huge shattered and broken H blocks.



David: So the H blocks were like the ones that we see in Peru at Pumapunku? Same kind of idea?

Corey: Except some of them were up into the ice, like frozen up and partially exposed out of the ice. Some of them were pushed down in the sediment with just kind of like the corner sticking out. And then there were broken pieces of the H blocks everywhere. And these were very, very large. Very large.

David: Now, you've said before that Antarctica was originally a habitable world, and that there was some kind of Earth axis realignment, a physical movement of the Earth in space that caused it to become the South Pole, thus causing the Atlantean flood. The waters that come in then quick freeze and turn into glaciers.

Corey: Right.

David: So these were ruins from before that happened most likely.

Corey: Right.

David: Okay.

Corey: And they were obviously crushed by the ice at one point.

David: Hmm.



Corey: Another thing, we saw all of these large triangle craft just . . . I couldn't tell if they were hovering above the ground or parked on the ground because of the lighting conditions.

And it was pretty well lit from all of the industrial lights reflecting off the ice in the general area of where this complex was.

And as we flew over, we see two conventional-looking submarines and a few of those very large black subs. And they had these cranes on kind of like a train track that were positioned and unloading part of the almost egg-shaped black sub that the top kind of like slid back like that and exposed the inside. And they were unloading.

And it was at this point that I started wondering how many of these outposts are there? Is there anything under the ground? What . . . You know, I started thinking all this stuff. And all of a sudden, all of these displays . . . I mean, like holographic displays started popping up all around.

And what I didn't mention is when we first entered this under ice area, the ceiling and the floors turned transparent on this craft.

David: Oh, wow!

Corey: So the view was incredible. The back of the seats were transparent. You could see through them. If you looked back behind you, you could see the burgundy area where people sit. But if you looked forward, it was just . . . you could just see everything.

David: That's wild!

Corey: Yeah!

David: Now, she had told you this was an intuitive craft.

Corey: Right. So all these displays started popping up, and I started looking at it and I was like, "Wait, I need to see, you know, see what I'm supposed to." You know, she told me not to get caught up in the data.

David: Ah.

Corey: And I really wasn't understanding all I was seeing – everything that was popping up. I saw sort of the map of the area we were in, and I saw two large areas and then four smaller outpost areas on the map.

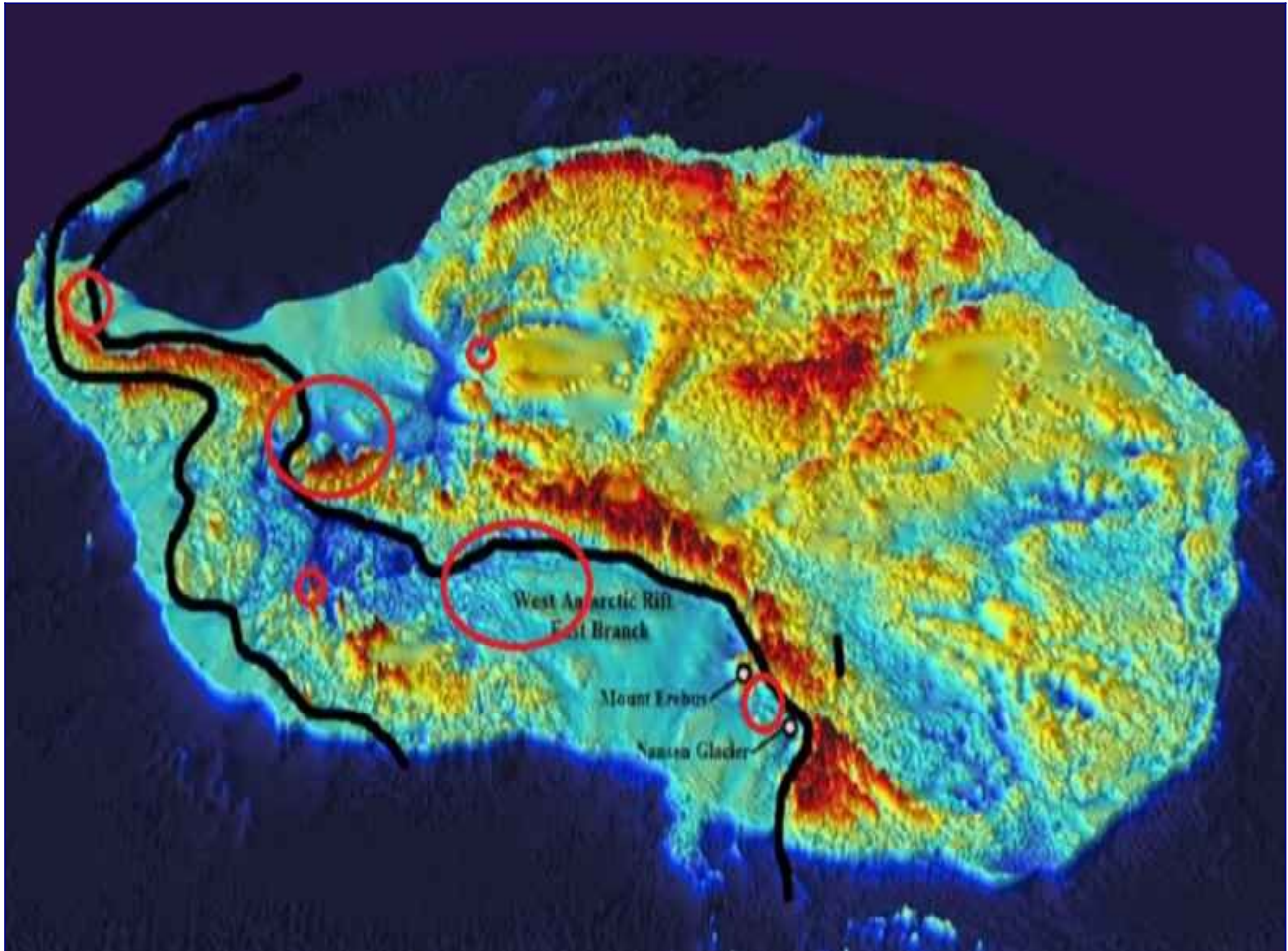

We pass over that industrial city. It gets darker again. And then all of a sudden, we're over like a bay area. And across the end of the bay area, we could see what looked . . . which was another city that showed up on the map that popped up for me.

And I thought we were heading right towards it, but we stopped over the water. And I look up, and I see this huge . . . The ice was 200~300 feet above the surface of the ground in most of the area, but in this bay area, it was 600 feet or 500 feet. It was much higher.

David: The ceiling was higher.

Corey: The ceiling was higher.

David: Yeah.

Corey: And there was this large hole, you know, 70~90 meters wide, that went up and then went off at an angle above us. It was a huge . . . and it's apparently where all of the thermal heat is escaping or . . .

David: Hmm.

Corey: So . . .

David: From this underground volcanism that you say is causing the igloo.

Corey: Yeah, and there was . . . Yeah, there was all kinds of volcanism and stuff down there.

David: Okay. Hence all the steam you're seeing.



Corey: Yeah. Yeah. So we stopped underneath it. And I think we're about to shoot up through it. But instead, “phst”, we go into the water, like flat, and like a belly flop almost, but just “phew” into the

water. And we're under water. And it's dark. It's pitch black.

And you know, we're, you know, traveling under the water. And then all of a sudden, we enter into this cavern type area where obviously these subs are coming and going from.

David: Hmm.

Corey: And we . . . I don't know how far, we head back a ways. And I see two or three of those subs coming with a long line of tiny little bubbles behind it and a light out the front. And this was obviously a rift.

And the rift started to curve around, and we traveled around curving, and then we saw this huge arch that was, I mean, I don't . . . It was so big. And it . . . what it had done is, a rift was curving around this way, and this was an arch that connected two rift or tunnel areas. And it was ancient.



David: And those little black guys at the bottom, what's that?

Corey: Those are the giant black subs that . . . That's how big this area was.

David: Wow!

Corey: It was just huge.

David: And this was built by somebody a long time ago?

Corey: Some ancient group. Some ancient group had built this big, giant arch. I mean, there were cracks . . . and it was a real smooth arch. There were cracks and areas where, like, pieces had settled to the bottom – had broken off.

We headed through that. I thought we were headed back to the Anshar base, and then we shoot up through the top of this rift cavern, and we pop out of the ocean in . . . where a blue swirl is. And then we go right back in.

David: Hmm.

Corey: And we're at the air command center (a part of the Anshar city in Inner Earth). And that was the end of that.

David: What time approximately do you think this was when you had this trip? Do you remember exactly? Was it in April of 2016, or March?

Corey: This was at the end of April, early May.

David: Okay. Now, I remember getting a briefing from you on April 27th is what my written notes say, and you had started to get some very unpleasant briefings. In fact, you mentioned that I think by that point you said you'd had eight or nine of them.

Corey: Right.

David: And this was the first wind that I got that you and I were not necessarily doing a good job, and that there was some very significant trouble that we were in with the people in the Alliance.

Corey: Well, all of these experiences, all of the information that I've just shared, was intel that the SSP Alliance and the Anshar stated was . . . it was critical to get the information out to the public, because there are people that also look at this intelligence in the Earth Alliance that they wanted to give them

the intel of the actionable intel. Because of some other operations that were going on, it was time critical.

David: And I guess because of the loss of Gonzales, they didn't have a way to communicate this intel anymore except through direct effort of you or me doing what we're going to do.

Corey: Correct.

David: What . . . I know what you told me on that briefing from April 27th, that you had eight or nine meetings. I didn't really get the full scope of how bad it was. But let's start to go into that now.

Corey: In the beginning, they said that the incident of me being chemically interrogated had destroyed basically my relationship with them and their trust in me.

David: So you said also that when you had that meeting with Gonzales at the metal table, that there was this guy writing things down on a piece of paper. And this guy ends up contacting you again.

Corey: Right.

David: So tell us about him, whatever you can say that's safe.

Corey: Right. Well, this guy was . . . he was a very, very unpleasant individual. He introduced himself to me and said, "You can call me the Wrangler." He said, "I am brought in when we have assets that are underperforming or are not doing what they're supposed to do to wrangle them."

And he said that in order for me to get some of their trust back, that they wanted to do what they called a chemical debrief.

David: Wow!

Corey: Yeah. And if I had any idea of what I was agreeing to, I would not have done so. It was just a euphemism for another chemical interrogation. One that I agreed to, and that they wanted to put me under so they could find out anything that I may have betrayed, and unknowingly betrayed. That's . . .

David: So they're worried about, in the haze of battle, that if you've been compromised and brought in, they want to know exactly how much stuff you leaked.

Corey: Right.

David: But since you were amnesic, you're not going to necessarily remember it. And then that means the enemy has a weapon they could use in a surprise attack against them.

Corey: That's how they presented it to me basically.

David: Okay.

Corey: So I agreed. This chemical debrief was . . . It was horrible. The chemicals burned. The other ones didn't when they went in. I mean, burned bad, to where I was like, "Ah! Ah!", you know.

David: Jeez.

Corey: And they just started laying in with all kinds of questions and everything. And I . . . that is kind of a fog to me. But the . . . What was really the most stressful part of my relationship with this Wrangler is the way he treated me. He treated me with complete disdain, told me that I needed to toe the line and start picking up some of Gonzales' work on the ground.

If I did so, they would give me more material support and technology to help me with issues I'm having with my body. They reiterated people that have been through what I've been through in the 20-and-Back that, you know, I'm going to start having more problems with eyesight, neurology, and he starts listing all these things.

You know, he said, "You know, you should wear lead sunglasses, the way your eyes are." And, you know, he was basically dangling a carrot in front of me.

David: When you said 'material support', this means they were actually offering you what could have been a potentially very high-paying job.

Corey: No, it was more of Gonzales' operational fund.

David: Ah! Okay. So it's not like a huge amount of money, but it would have been money.

Corey: Yeah.

David: The comments that we had, people are like, "Well, wait a minute, now I'm confused. This is the Alliance. These are the good guys. Why are they treating **Corey** this way?"

So could you speak to that for a moment?

Corey: Well, you know, they . . . They've . . . They came basically out of Cabal programs. So you know, they're damaged individuals. They're . . . They have intentions of bringing all of this technology and disclosure to humanity, but they're still damaged individuals.

And with all of these new influxes of galactic energy that are coming in through the sun and being buffered by the spheres, we're seeing a lot of strange behavior in people. And they're not immune from it.

David: Right. So this vibrational increase is causing, as you've said to me off camera, end time madness. People are acting more crazy. They're emotionally agitated. You also mentioned that their karma, old karma is coming up for them.

Corey: Right. People are being forced into karmic cycles until they learn what they need to learn and accomplish what they need to accomplish.

David: Why does he keep bringing you back over and over again?

Corey: It's all about intimidation and coercion for me to become their asset.

David: Now when you eventually briefed me on this the day before I was to start speaking at Contact in the Desert, you also told me some pretty shocking stuff that made it sound like they were trying to blackmail you, about beams that were aimed at your house and my house.

Corey: Right. They said . . .

David: So talk about that for a second.

Corey: They said that they would be able to help you and I with technology that was mounted around and point at our bedrooms, our . . . where we sleep that interfered with our dreams and our ability to have cogent thoughts and that kind of thing.

David: That they could basically shut that stuff down.

Corey: Right.

David: But they're not gonna do it unless you accept the job.

Corey: Right. And whether that's true or not, I don't know. This was such a manipulative person and situation, you know, it's really hard to tell.

David: Okay. So you tell me this, and then I do not act because . . .

Corey: For about six weeks.

David: . . . I'm in the middle. And it's driving you crazy because I apparently . . . I just really didn't grasp . . . When you told me this, you were very emotional. You didn't say very much.

I really didn't get how badly you were being tortured, or how much of it could hinge on me . . .

Corey: Yeah.

David: . . . and what I was doing. So the Wrangler meets with you, and the message is very, very bad.

Corey: Right. And they gave me basically an ultimatum. They stated that the next time we had a meeting that they expected me to give an answer on whether I would be an asset or an operator for them here on Earth. And in doing so, I was going to be very much under their control, under their thumb.

So, I had told you this before the . . . when we were in Joshua Tree. And then when I'd gotten home about a week later, I was waiting for this time on this date when I was going to have this meeting and delivered the message to the SSP Alliance that I was turning them down.

And I knew it was going to be very contentious and very upsetting – their reaction.

So I'm sitting there, and I'm waiting, and a Blue Sphere comes in the room. And I hadn't seen one in a while. And it came into the room, zipped around, did the normal thing. I indicated I was ready, and I was brought up to a Blue Sphere before Tear-Eir.

And behind Tear-Eir in the background I could see all the other Spheres, and there was a very large amount of what looked like static electricity – like electricity between them. It was very active.

And I had . . . I conversed with Tear Eir, and Tear-Eir told me that they had communicated through Gonzales that I was not going to accept the offer and that they were not to pick me up anymore.

David: And if you had been picked up, what might have happened with the Wrangler?

Corey: I don't know. It wouldn't have been good, because he was very angry that the intel hadn't got out. He was very angry on several things.

David: Angry at me, too.

Corey: Oh, yeah.

David: I mean, you had given me some very contentious stuff about me.

Corey: Yeah. He was . . . Yeah, he's just very . . . a very triggered, angry person.

David: So it appears now that you are not going to be abducted by this Wrangler any further.

Corey: Right.

David: But that also means they're not going to be able to replace Gonzales with you. And didn't he tell you that you were the only one that could be replacing him.

Corey: Right. Well, the Blue Avians, you know, they delivered that message to . . . through Gonzales to the Wrangler. And then they went on to tell me that I needed to converse with Kaaree and let her know that this big meeting over the Muhammad Accords would not be occurring because the groups associated with the Draco were refusing to take part. So without all the signatories, they couldn't have the meeting.

And I was also told about . . . We're about to experience a lot of 'end time madness', that the SSP were not immune from it, and that the strangest part, towards the end, was that when masses of people start having visitations from dead family members, that that is a big sign. It'll . . . It's gonna happen en masse that that is a big sign that the veil has thinned to the point to where we're about to go through the transition.

David: Ascension, in other words. And they told you . . . I remember you telling me many of the things that you folks who are into the UFOs and have been watching the show are interested in, expecting to see, that those things will happen very soon . . .

Corey: After these . . .

David: . . . after these mass ghost sightings start to occur.

Corey: Right. So after this meeting, I was brought back to my home in a Blue Sphere. And very shortly after, Kaaree contacts me through this etheric . . .

David: The Construct.

Corey: Yeah, the Construct. And I was reticent to tell her that her meeting had been turned down, but I did, and she didn't miss a beat. She said, basically that was . . . this kind of thing is expected. It's basically the opening of negotiations. This is how those beings, basically that's how they negotiate.

David: Right.

Corey: And she did not seem disheartened or discouraged by it at all.

David: And this basically brings us up to date now . . .

Corey: Yes/

David: . . . with what's happened to you up until the time of this taping.

Corey: It does.

David: So, **Corey**, again, I am very glad that the Wrangler is not able to meet with you anymore. I was just absolutely tormented when I found out that my inactivity not writing these articles was causing you to be tortured. And I did say, and I asked you to tell them, please bring me up there instead of you. I didn't want you to go through this. But now we're off the hook. Thank god.

So we're getting this intel out. We're going to continue to get the intel out expediently because we do not want to get into this trouble again.

Corey: Negative.

David: So we've both been 'inspired'.

Corey: Yeah, we'll call it 'inspired'.

David: All right. And I hope you out there will understand that it's up to all of us to move the ball forward for Full Disclosure. And you're a part of this, too. Your efforts are needed.

Help spread the word. Let people know about this show, and help us bring about the new Golden Age for humanity. I'm **David Wilcock**. This is "[Cosmic Disclosure](#)" with **Corey Goode**, and I thank you for watching.

[Cosmic Disclosure: Anniversary Special](#)

Season 5, Episode 9



David Wilcock: All right, it's great to see you. I'm **David Wilcock**, as I'm sure you already know. And what you're about to witness here is really cool. We have decided to give you a special treat, a life review, if you will, of the last year of "[Cosmic Disclosure](#)", some of the highlights, some of the most impressive, most shocking, most amazing things that came out in the course of my discussions with

Corey Goode over the last year.

I know you're going to love this. Check it out.

LUNAR OPERATIONS COMMAND

David: Tell us a little bit more about the LOC (Lunar Operations Command). I guess, first of all, what does it look like as you're flying into it?

Corey Goode: Well, you can tell it's been built and added onto quite a bit since the '50s. It's built into the craters and into the rocky area to where it blends in somewhat.

Some part of it is built into the rock. Very little of it is above ground.

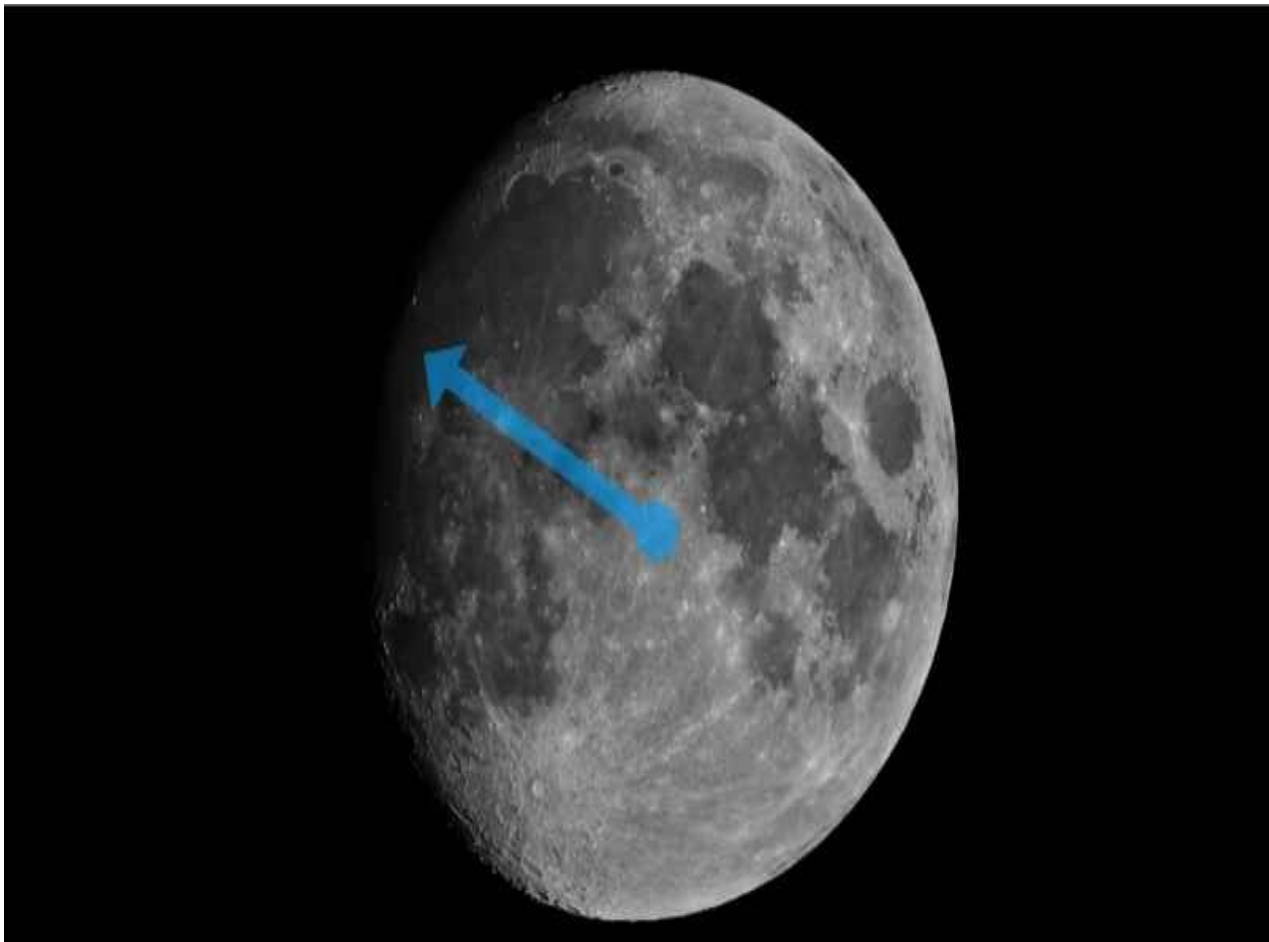

David: Oh, okay.

Corey: Most of it, I have not had access to. I have seen a diagram to where it somewhat goes into a bell shape further and further down you go. And I've only had access to the upper levels.

David: So even though it's a bell shape, you don't actually see the bell on the surface of the Moon?

Corey: No. It's like looking down at the top of the bell or the tip of a pyramid. You just see the smaller top, or the tip of the iceberg, I guess you would say. The rest is below and spreads out as it goes on.

David: If there are this many craft going to and from the LOC, and you say it's on the dark side of the Moon, how could it possibly have been kept secret from us? Couldn't people, with their telescopes, see all the ships coming and going from the Moon?



Corey: People do see that. There's actually another base on the backside of the Moon that belongs to human beings. It belongs to one of the Secret Space Programs called Dark Fleet that a lot of people see craft coming from.

I can give more of the location of that one. If you're looking at the Moon, it's at about the 10:00 position.

People have filmed and seen flurries and swarms of craft leaving and coming from that area quite a bit, amateur astronomers with video cameras hooked up to their telescopes.

This is something that has been seen.

David: When was the LOC actually built?

Corey: The LOC was built onto an existing Nazi facility that had been built in the latter parts of the '30s and '40s.

David: So it goes that far back?

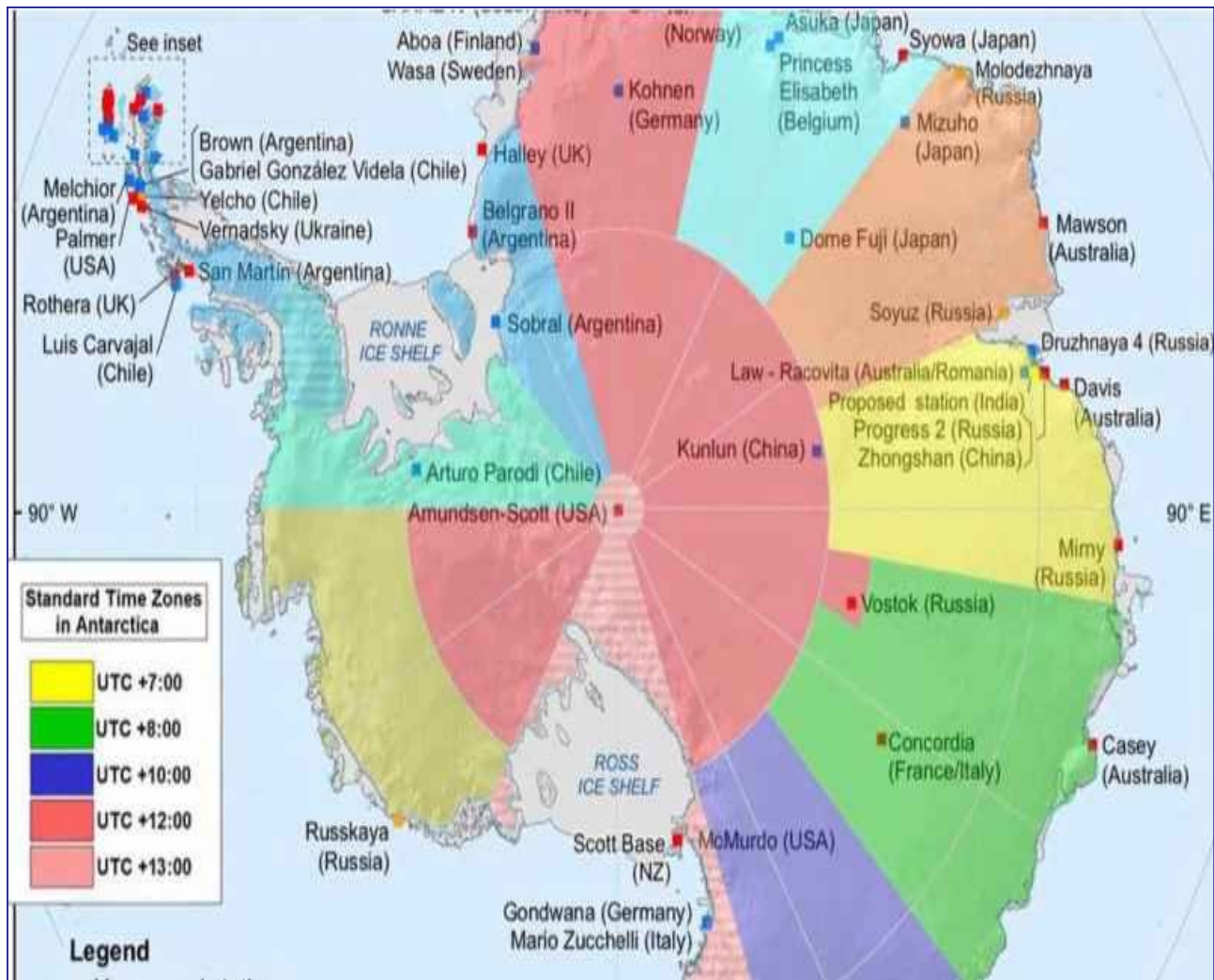

Corey: That far back. Once the industrial might of the United States became involved, they really started putting a lot into it and built it out like crazy. They started really building in earnest in the late '50s on it.

The Moon is a very strict zone that is like a giant Switzerland.

David: It's strange that you would say that the Moon is this neutral Switzerland type of area because it's right next to the Earth. If it's our moon, shouldn't it be our property and we get to have control over the Moon?

Corey: No.

David: It doesn't work that way?

Corey: No. If you've seen the maps of Antarctica, how it's sliced up amongst all the nations, . . .

David: Yeah.

Corey: . . . the back of the Moon is that way too. and all these different regions are pretty much owned and inhabited by different ET groups.

David: Really?

Corey: And there are some groups that have bad blood or have warred with each other going back many, many, many thousands of years, but they have installations that are just a couple kilometers away from each other.

And they have been there for many thousands of years in peace. There's some sort of diplomatic agreement about the Moon. There's something very special about the Moon being a very diplomatic neutral zone.

David: What is it like when you are in the LOC? Do they have apartments that you can go to once you get inside? Is it just wide open conference rooms and little chairs? What happens when you go inside?

Corey: Well, until recently, I had never been to the VIP area. I had always been to just the area to where they have small, not really apartments, but small little dwellings to where it has two to four bunks. The halls are real narrow.

You move over to the VIP area, the halls are wider. There's wood paneling on the walls, like cherry wood – nice walls, very upscale. It's a dramatic change when you go from one area to the VIP area.

David: Could you wander around and try to find a restricted area, or do you have military escorts that lead you around. How does that work?

Corey: Well, you're allowed certain areas. There are marks, paint lines, on the floor . . . lines that are a different color that lead to different areas.

David: So, if you were red, then you'd just walk, follow the red line to where it leads to?

Corey: Right. And, like I said, I've only been . . .The top floor is where most of everything takes place. The next two floors were the medical and some other more advanced medical stuff take place. I have never been further down than those.

There are some people recently that have been taken on a tour that have gotten to see a lot more than I have. There are some people that are stationed there and work there, but it's more of a way station. People are coming and going from it all the time to go further out into the solar system and beyond to go out to other stations, other bases, to go out to their assigned vessels.

SUPER FEDERATION

Corey: What I've described as this federation super-council, . . .

David: Okay.

Corey: . . . this is a Super Federation made up of other federations, councils, and other different organizations and groups.

David: So hence, the word “super”.

Corey: “Confederations”, I've heard used.

David: Right.

Corey: And it's kind of like a giant UN of all of these different federations, confederations, councils that come to meet. And there are 40 main groups, with 20 other groups that are there a fair amount of

the time, but not all the time.

Now, these groups are more of the human-looking, human type, and their bases seem to be mainly on the back of the moon and on moons of some of the gas giants, especially Saturn, so much so that there are areas around certain moons of Jupiter and Saturn that our vessels were completely forbidden from going anywhere near. And this is in our own solar system. These areas were off limits.

David: Our vessels' meaning your Solar Warden faction?

Corey: The Secret Space Program.

David: Right. So whatever faction it was . . .

Corey: All of Earth's Secret Space Programs were not allowed. No Earth space vessels were allowed within a certain distance of these moons.

There were 22 genetic programs that were going on.

David: What does that mean? What's a genetic program?

Corey: Programs of them mixing their genetics and manipulating our genetics. The information was presented almost as if, going back to the college analogy, there were 22 term papers competing with each other, and each of these genetic experiment programs were presenting their information in that manner.

They were somewhat competing with each other. They weren't all working . . . They weren't all hand in glove, working together.

David: Did this involve these human-looking extraterrestrials . . .

Corey: Yes.

David: . . . splicing their DNA with ours, that kind of thing?

Corey: Yes, and manipulating our DNA. There was also a spiritual component. They are very much involved in a part of the experiment. It's not just them experimenting on us. They're a part of this Grand Experiment too.

David: Did they have a goal? Why are they doing this? Why do they care?

Corey: That, I do not know. I don't know if they're doing it just because they can, if they're trying to create some sort of super-being, but a lot of it didn't . . . Why would they try to create . . . mix all of their best genetics together and then manipulate us in our civilization to keep us down?

David: How long do you think this program has been in action for?

Corey: Of the 22 different programs, they've been going on for different lengths of time, but the genetic manipulation of what we are has been going back at least 250,000 years.

David: Wow!

Corey: But these programs, they vary, in their length from 5,000 going . . . They're all different lengths of time.

David: This doesn't sound like something that our secret Earth government or elected government would want these folks to be doing. Could we stop them?

Corey: I don't think so. I mean, this is something that we've just recently been able to beg to get a seat at their table to be a part of the discussion.

David: So would these be negative-oriented extraterrestrials or more neutral – not really the benevolent type?

Corey: It depends on your point of view. It's all amount of . . . It's perspective. It's hard to say this group is positive, this group is negative out of all those groups, because they see what they're doing as a positive thing.

MOON BASES

Corey: It's going to be overwhelming to learn that there is a vast infrastructure throughout the entire solar system with everything from mining operations in the asteroid belt and on moons and planets to procure raw materials, to industrial complexes that produce technologies, and colonies of human beings that work in those industrial complexes and support this large industrial machine that is throughout our solar system.

David: What moons are we talking about? How many of the moons in our solar system – because there's a lot of moons in our solar system.

Corey: Yes.

David: There's at least 100.

Corey: Right. There's a lot more than 100.

David: Okay. So how far did this go and how much did it expand over time? What were the earliest moons that were conquered or landed on?

Corey: All of this is very tricky diplomatically because a lot of moons are off limits to everybody, because they're diplomatic territory – 'owned' by some of these 40 or 60 groups.

David: The Super Federation.

Corey: The Super Federation people – especially around Saturn.

David: Really? Saturn has a lot of moons.

Corey: Yeah, yeah. But there was a lot of activity around the moons of Jupiter.

David: Germans and ICC people?

Corey: Um-hmm. And Uranus, and then the asteroid belt.

David: Now, I had Jacob, my space program insider, who I've mentioned before, tell me that some of these moons, the entire interior would be like a geodesic shape that has - like a dodecahedron, let's say – pentagonal faces with trees and habitable land. Like the whole interior of it is hollow. You can fly your craft along, and you get to a certain point, and then you make a turn, and you fly this way.

And like when you get inside there, it's almost like a paradise-type of world. Do you think that that might be some of what is going on in these Saturn moons, that they're that built out inside?

Corey: Mm-hmm.

David: Did you encounter information like that yourself?

Corey: Yes.

David: Really?

Corey: And I encountered information that I've tried to stay a lot away from. All of this is so incredible, but our Moon is also an artificial body.

David: That is something that almost everyone in the know, that I've spoken to, has said.

Corey: It's in a locked orbit with the Earth with almost like a tractor beam technology that has locked it in a orbit with the Earth. And they've found the energy field that goes deep within the Earth, to where it's focused, to anchor the Moon. And the Moon only changes position, as it goes further from the Earth by, I think, centimeters every certain amount of years or something.

David: You're saying that's not normal for a moon?

Corey: Absolutely not. The Earth's density and the gravitational effect it has in timespace, creating a torsion field by its spinning and contorting spacetime is not enough to capture something of the density . . . of what scientists say the density of the Moon is.

And because of the spinning of the Earth, it should have an effect on the Moon to cause it to spin.

David: Oh, wow!

Corey: But the Moon is locked in. It doesn't spin. It's locked in too close to the Earth, and it is not something that could have been captured. None of the scientific models have worked, that it was once part of the Earth and was flung out. It was around 500,000 years ago that the Moon became a satellite.

MARS BASES

Corey: The first couple of German seed colonies that actually made it on Mars were within the first 20 degrees of the polar regions. There was one in particular that the ICC used to expand and build off of, and this one was somewhat in a canyon area, into the side of a canyon, and advanced in and was under the surface of Mars – not on the surface.

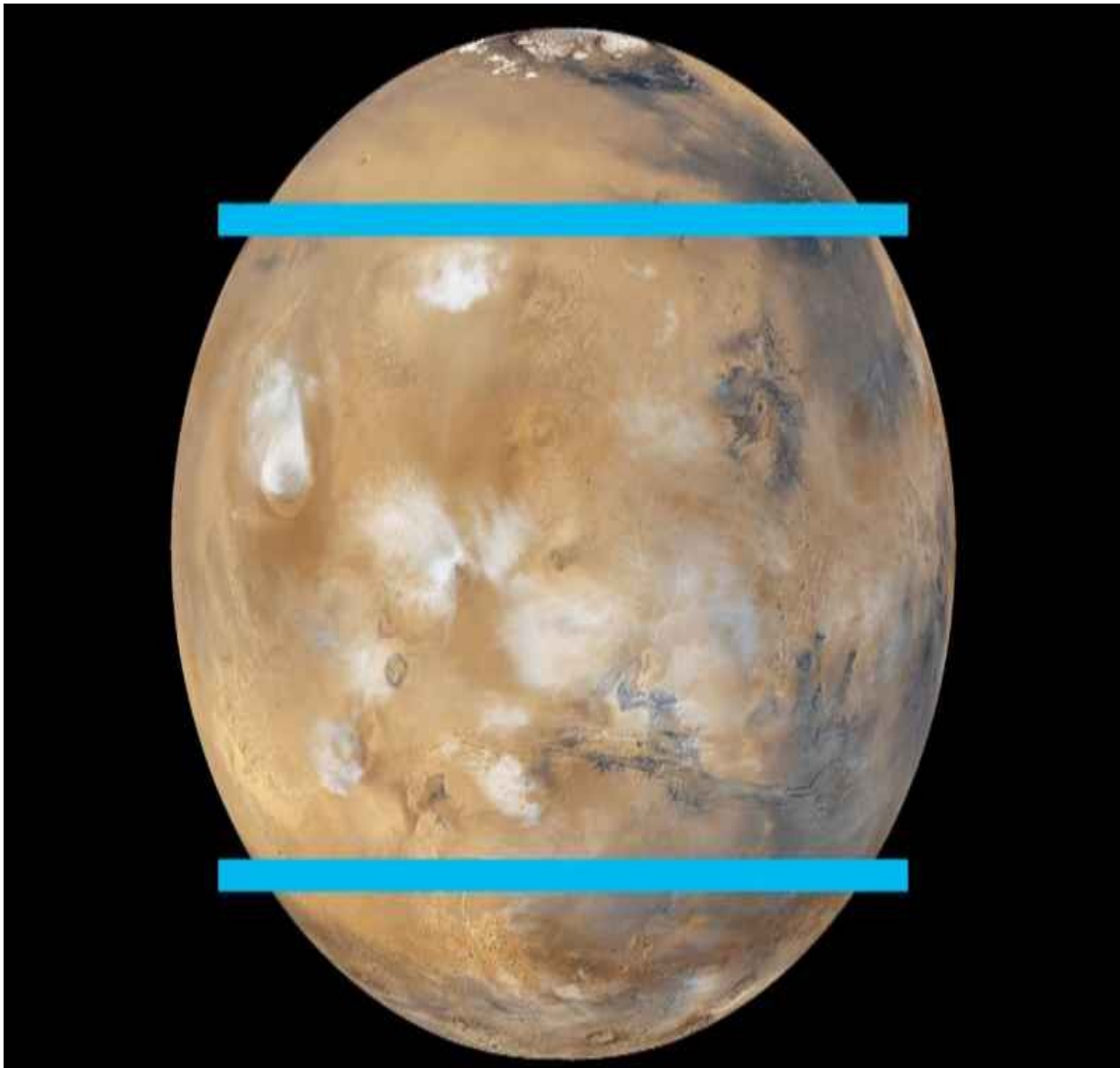

David: And you said that some how they hollowed out more space inside the Earth was with these what I was told were called Fifth Gen-type nukes, where they just create a big, sudden explosion with no lingering radioactivity?

Corey: Yes.

David: The one that became the mainstay, was it in the northern or southern hemisphere?

Corey: The northern hemisphere was where the first main base that was a German name, in the beginning, which was built . . . was built out.

David: Okay.

Corey: And it was built out in a huge way. It was built out to contain a large amount of engineers and scientists. And also, a little ways away, an industrial complex was built where they were going to start producing the, I guess, the items that they needed – technology that they needed that came from raw materials they mined on Mars, moons, and in the asteroid belt.

They took these raw materials, turned them into usable materials, and even composites, and created what they needed in these rather small plants in the beginning.

David: So what was considered to be the desired technology that they were building out there in the beginning? What was their initial attempt? What did they want to make?

Corey: They were building what was needed to expand on Mars.

David: Okay.

Corey: So in the beginning, they were just building what was needed to expand their infrastructure on Mars.

David: So are they building materials on Mars out of local stuff, like you said before, involving the Kevlar bags and then making concrete out of local earth from the Mars sphere? What was the building technique? You said that these industrial facilities they had were building the things they needed.

Corey: Yes, they were building . . . The raw materials were coming from mining that was going on on Mars, on various moons and the asteroid belt. These raw materials were taken to the Mars' industrial areas further away from the colonies and converted into usable materials, whether they be melted down into certain metals that were put into dyes or forms or converted into composite materials.

David: When was the first stable base that lasted on Mars?

Corey: I think they . . . around '52 to '54 is when they really started getting the United States to sign the agreements, and they had only just really got a good foothold on Mars by then. They really had a lot of setbacks on Mars. They lost a lot of lives.

David: So almost like an 18-year struggle.

Corey: Yeah. It was . . . I mean, they really did the pioneering work on Mars.

David: But they had better success building mining facilities on asteroids and moons prior to stabilizing Mars?

Corey: This was at the same time.

David: Oh.

Corey: Yeah. Once they had a stable area to call their own territory, then they were then starting their mining operations. Their mining operations were more . . . I guess when a geologist goes around a large region and is picking up certain rocks, doing core samples, getting a good idea and then labeling certain areas and grids. I think it was more of an excavation and figuring out what was out there. When they found certain things they needed, they would start small mining operations.



You might think that you're in some sort of naval facility or something. The living quarter areas are all labeled in alphanumeric. It looks very, very much like a military installation.

There was one place that we went that they had to fix a damaged piece of equipment that was essential, that the ICC couldn't get their personnel to in a manageable amount of time. And we were escorted to . . . told not make eye contact with anybody, not to talk to anybody, that whole thing.

And there was a wall where people were like hanging art. I mean, it looked like they were doing some things for the mental health of people to make them not totally depressed and suicidal.

David: Sure.

Corey: But the people looked gaunt, pale and just almost like drones – just going about their day.

David: Were there photographs of cool-looking ruins from old civilizations that you saw?

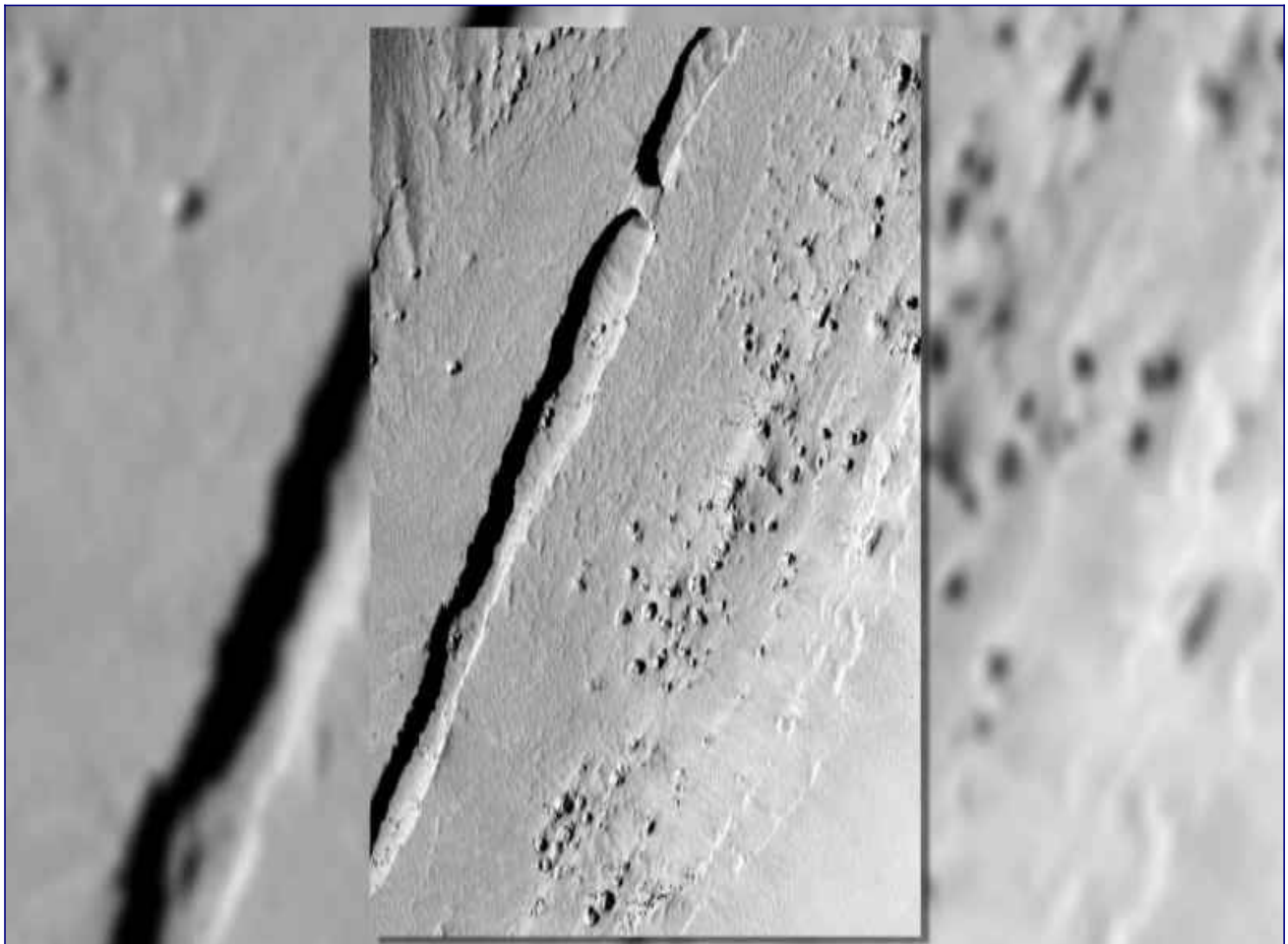

Corey: Yes, of ruins and of aerial photographs of areas, the huge volcano.

David: Olympus Mons.

Corey: Olympus Mons. There are lava tubes that are 10 times the size of the lava tubes we have here.

And they are perfect for sealing and creating an environment on the inside, and you have an easy, ready-made base. And that is a very highly coveted area to create bases.

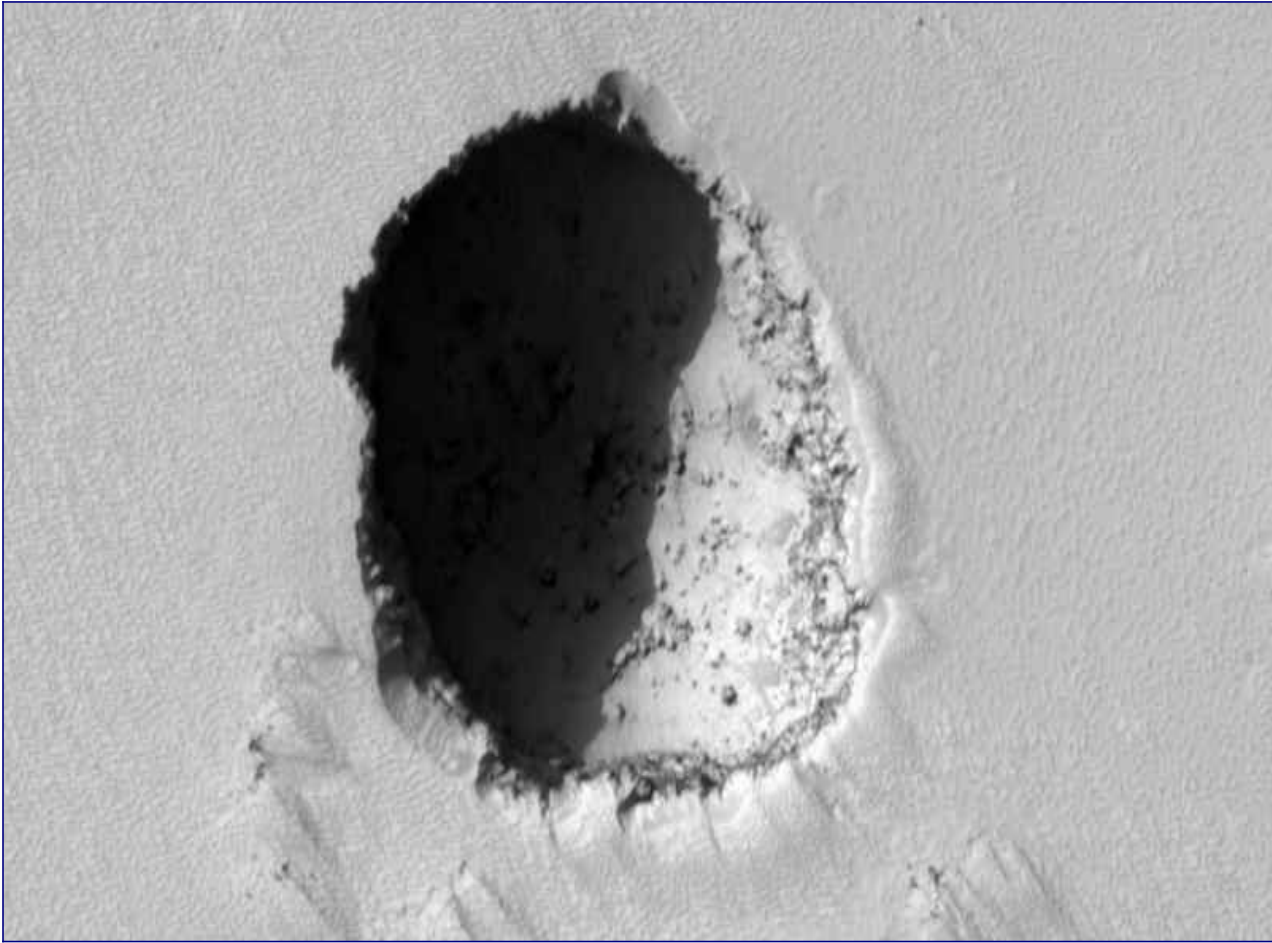

And the Germans wanted it. Later, the ICC groups - I guess the modern space program groups – wanted to utilize that area, but it was already occupied by another group. There were a lot of them, and they defended it fiercely.

David: Really? Do we know anything about what they look like or where they're from?

Corey: Yes. There's a treaty between some of these groups. One of the groups are a reptilian type, and the other are an insectoid type.

David: That's kind of what I expect. Ha, ha, ha.

Corey: That is a very coveted area.

David: So when you say 10 times bigger than lava tubes on Earth, are we talking five miles wide, 20 miles wide, 50 miles wide, top to bottom?

Corey: I mean, huge. Bigger, I mean, they dwarf any of the caverns or the tubes that we have here.

David: Most of which we don't know about, I guess you're saying.

Corey: Right, yeah.

David: Because they already have huge cities built in them.

Corey: It has to do with the size of the volcano, the gravity, the barometric pressure on Mars, and the way that . . . how come they're so huge.

David: So could they be even like 100 or 200 miles long from top to bottom?

Corey: I would be speculating.

David: Okay.

Corey: I didn't see any hard data on how many meters or yards or feet they were.

David: But given that some of the cities here on Earth, I guess, can probably hold hundreds of thousands of people, you're saying that in these lava tubes, you could have millions of people.

Corey: There are millions of beings . . .

David: Really?

Corey: . . . living in these lava tubes.

David: Wow! What are they doing?

Corey: Just living out their life cycles there.

SOLAR WARDEN

Corey: I'll start with the oldest, which is Solar Warden. They were started back in the late '70s, '80s, during the SDI – Strategic Defense Initiative, I think, is what that stood for – just before and after Reagan.

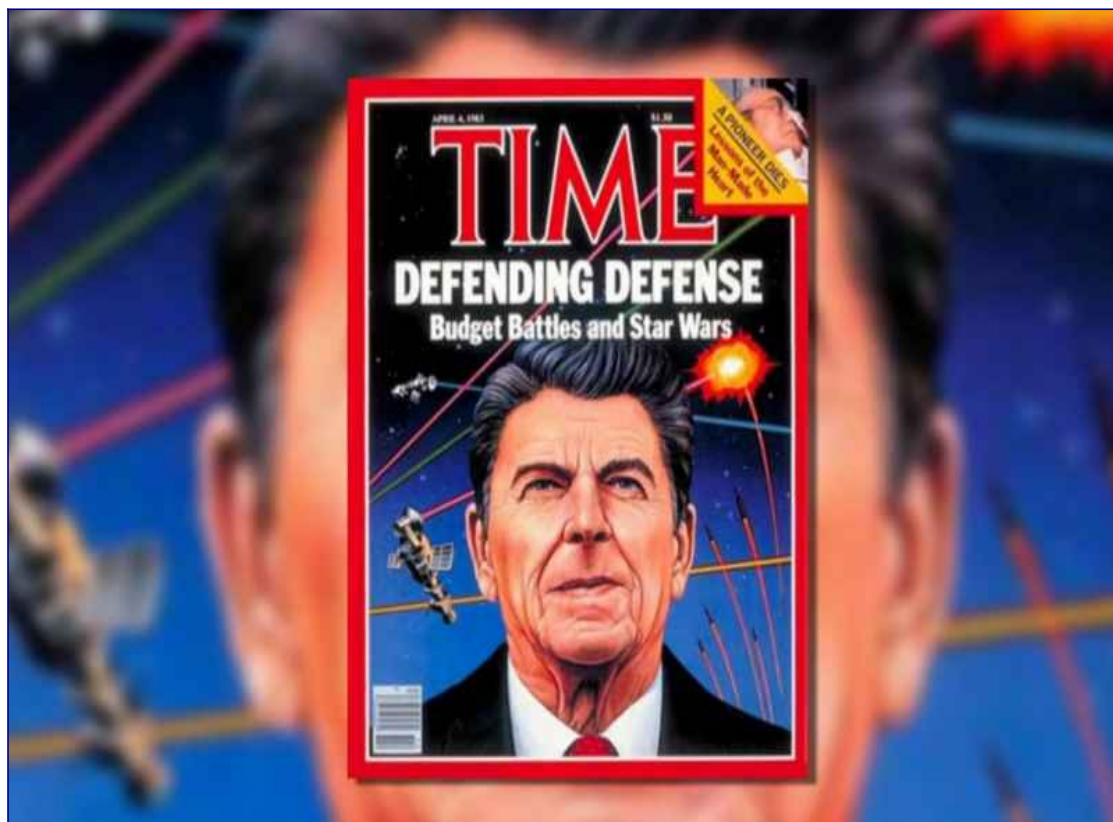

David: What was Solar Warden's original responsibility?

Corey: They policed the solar system from intruders.

David: That would be groups that are not part of these 40 that are the Super Federation?

Corey: Right. And also somewhat of a space traffic-control, air traffic-control. They took care of that.

David: Couldn't some ET group just interfere and invade with vastly superior weapons and technology? I mean, how could a group from the '80s be able to police our solar system against, potentially, anybody that could try to invade here?

Corey: Well, they wouldn't have been able to hold their own with a large invasive force, but most of the groups that passed through were only in, maybe, one to a handful of vessels. There's so many different groups that pass through our area.

David: And I would guess it's sort of like gang warfare, where the 40-some-odd ET groups that have sort of claimed this as their turf, with whatever level of technology they have, they're also going to defend their home turf from an invasion.

Corey: Right.

David: So Solar Warden is not necessarily meeting a tactical force. They're not having a weapons-up fighting stance when you say they're policing the solar system. Or are they?

Corey: They would engage small numbers when they had to, but they were not ever a huge force to be reckoned with.

David: So most of these unwanted entrances into our solar system would be more small groups of ETs or single craft that are trying to be sneaky?

Corey: Right.

David: Just trying to slip in?

Corey: Little marauder groups that would come in and do hit and runs to come in and take things and leave.

As Solar Warden has started a cold war – pretty much, a cold war – they started to fly in front of the International Space Station to “accidentally” show their vessels, little things like that, in the beginning.

David: If Solar Warden is going to try to create disclosure, where obviously the other parts of the Space Programs don’t want it, couldn’t that lead to a shooting war between these factions?

Corey: Yes.

INTERNATIONAL CORPORATE CONGLOMERATE

Corey: You have the ICC, the Interplanetary Corporate Conglomerate, which is pretty much the largest. They own pretty much all the infrastructure out in the solar system. You have . . .

David: And what corporations?

Corey: Just about every aerospace and other than aerospace, it’s a huge amount of...

David: Lockheed, Boeing, McDonnell Douglas, Hughes Aircraft?

Corey: Yes. Just, all of the above. And not just American corporations.

All of these aerospace companies and other engineering companies started to build all of the secret space technology.

The military and the “government” itself could not do this. They did not have the ability to build all this. They didn’t have the “infrastructure”. But the Germans highly coveted this infrastructure because they were already out there, and they needed this infrastructure to grow.

They had big plans for what they had already – they had a foothold out there. And they wanted to grow. They had large plans, and these plans – when they brought information to some of these aerospace companies, that they had been out to the asteroid belt and found entire asteroids that were made of precious metals that they had already been mining some, dollar signs popped in their eyes, in the eyes of these US capitalists.

So they fully got behind this German grand plan to build out a giant infrastructure into outer space.

David: How soon after they got to Mars and they got successful, stable encampments, did they start building facilities on asteroids or other moons?

Corey: Almost immediately.

David: Really?

Corey: Yeah. The Germans had already started mining certain asteroids. And this is one of the reasons the ICC wanted to go out there. They heard there were asteroids out there that had platinum and gold.

David: Ha, ha.

Corey: And the talk down here on Earth about there being hardly a discrepancy in gold, gold being rare, silver being rare, that is a total manipulation. I mean, just on Earth, the syndicates have hidden a bunch of gold.

David: Right.

Corey: There's tons of gold. And the gold that they're finding in these asteroid belts, atomically, you look at Earth gold and this gold – they're the same. They don't have different atomic structures. It's gold.

David: Wow!

Corey: So there is plenty of gold in the solar system and so many tons of gold, and platinum, and silver, and other elements in the asteroid belt that have been . . .

David: Could you actually find entire asteroids that are just a piece of gold or a piece of silver?

Corey: Well, I wouldn't say that they're entirely a big nugget of gold, but are very much gold.

David: Did the ICC or the Germans develop advanced computer technology faster than we did on Earth that they could start to use in all this robotic mining and things?

Corey: Yes, they've had computer systems and quantum computers much, much longer than – way before Bill Gates and IBM started to put out motherboards and integrated chips. The ICC always kept the most advanced toys.

DARK FLEET

David: What is it about the Dark Fleet that earns the name “Dark”?

Corey: A number of reasons. Well, in black ops, when there is a dark program, it is completely compartmentalized to where no one receives any intelligence. The other Secret Space Programs received very little information about the Dark Fleet's mandate, what they were doing, what they were up to.

David: Really?

Corey: Their bases were completely autonomous. Other Secret Space Programs did not get to go to their bases. Their craft were of a different design usually.



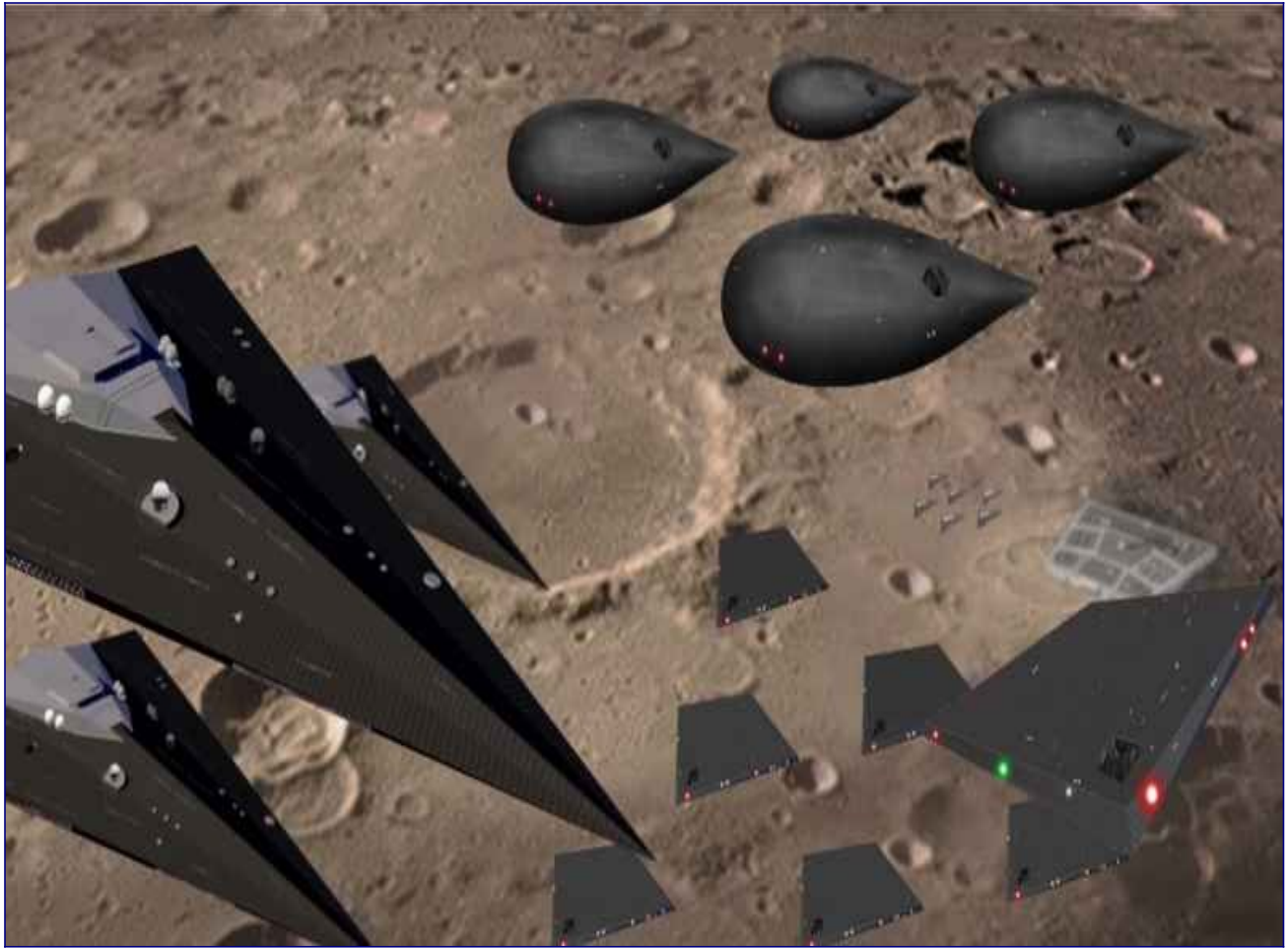

They had several different types of vessels that you would see that you would associate with them.

David: Well, could you describe some of what made these vessels different? What were their characteristics?

Corey: Yeah. And one of them is a very large wedge-shaped that is very much like “Star Wars” – the Destroyers, I guess, very much like those, but they're a little bit more sleek.

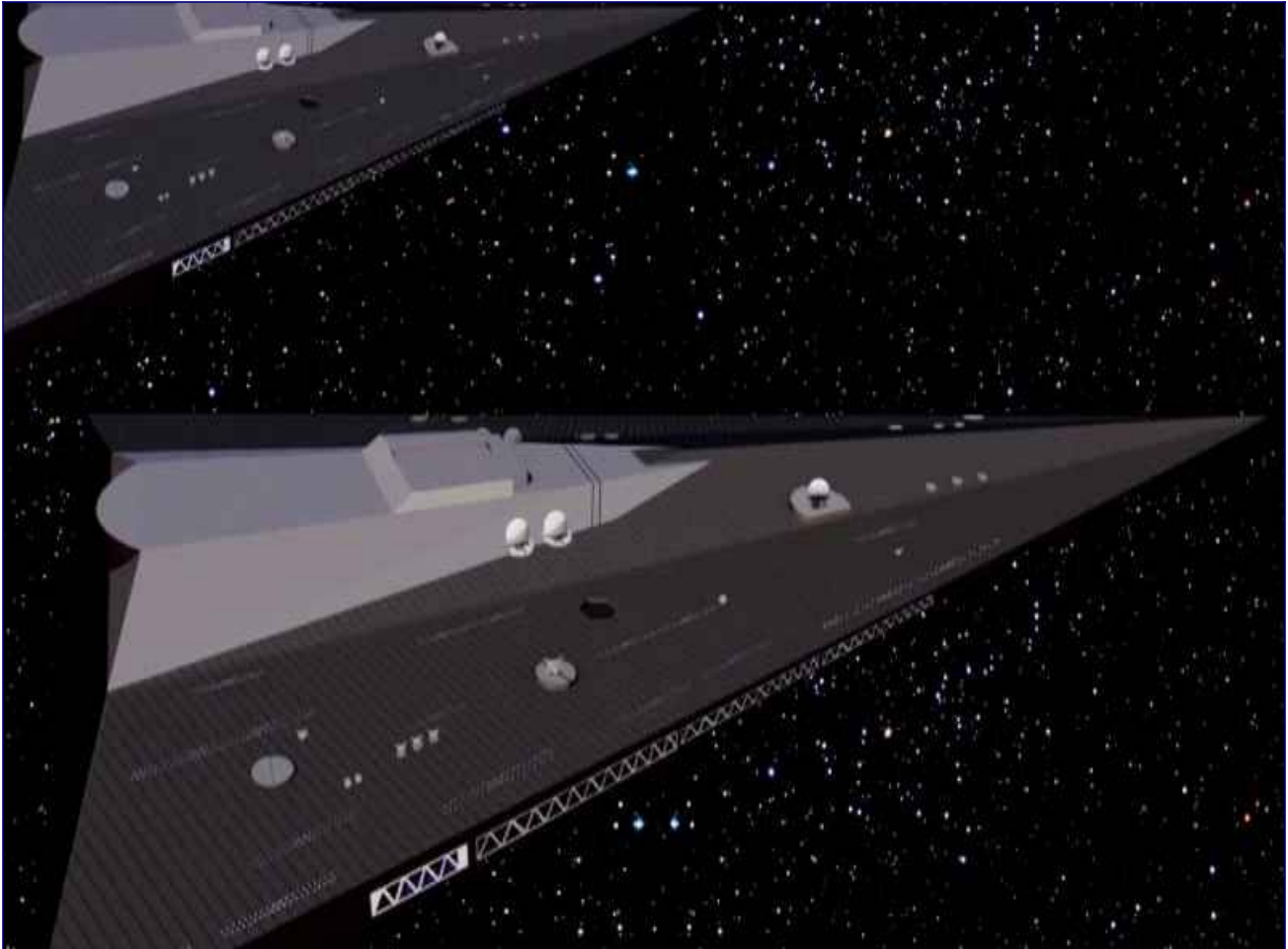

David: What about the little thing on top? Is that there?

Corey: Similar.

David: Really?

Corey: Similarly, but not as high, but similar.

There's also a very large diamond-shaped vessel that they have.

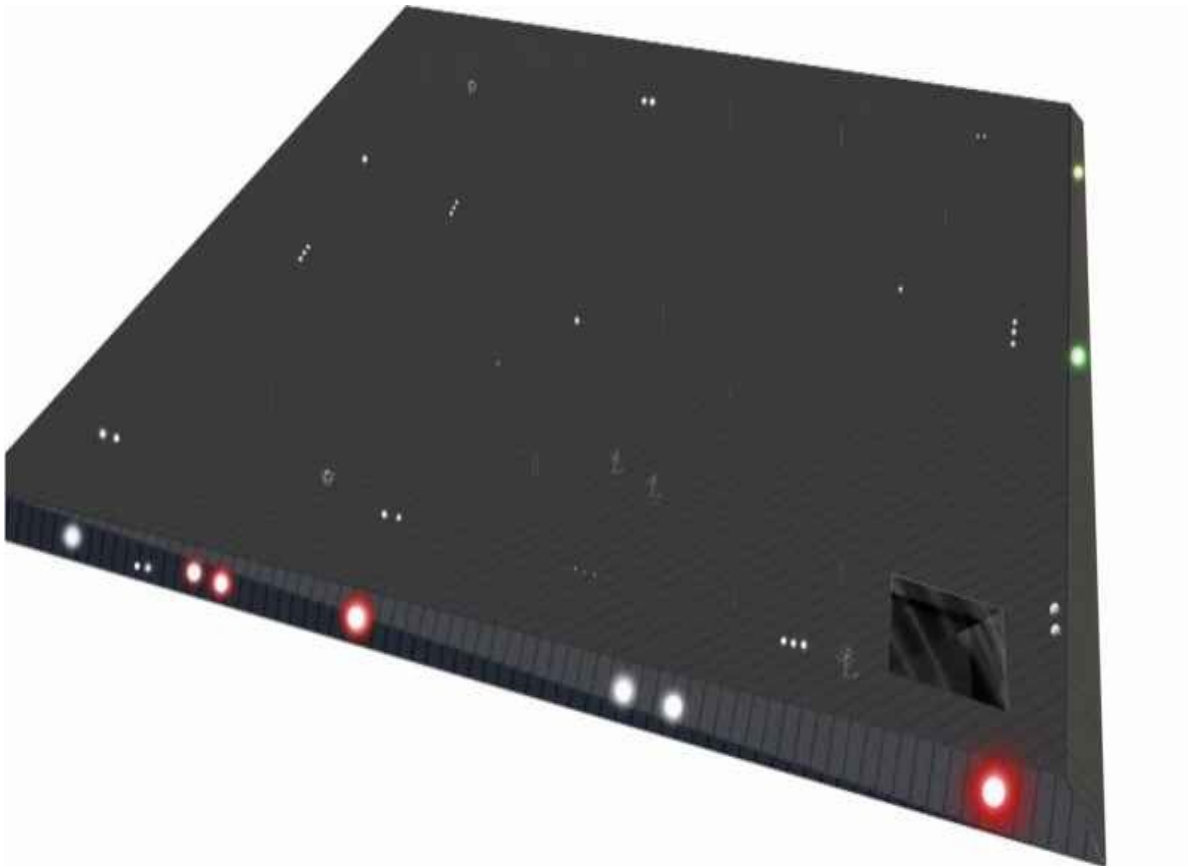
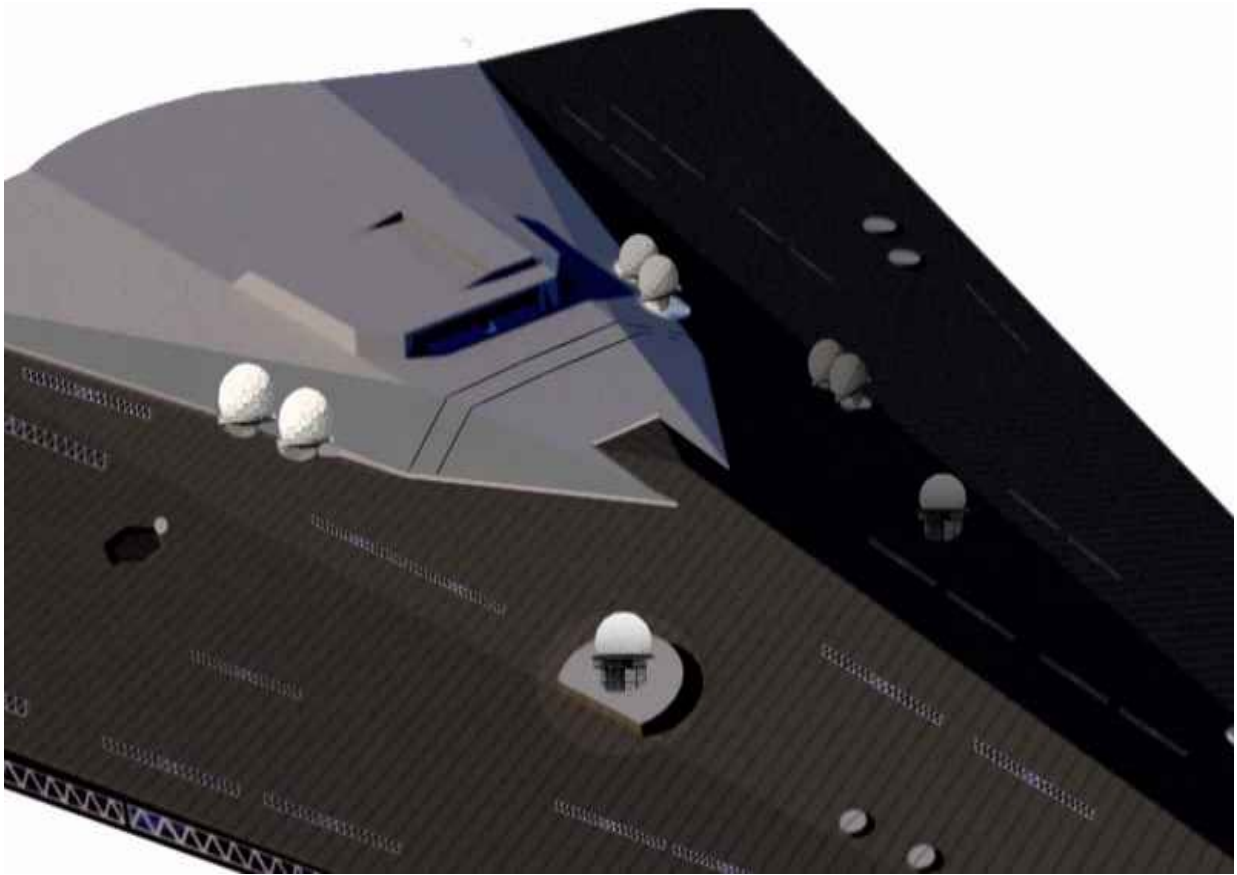

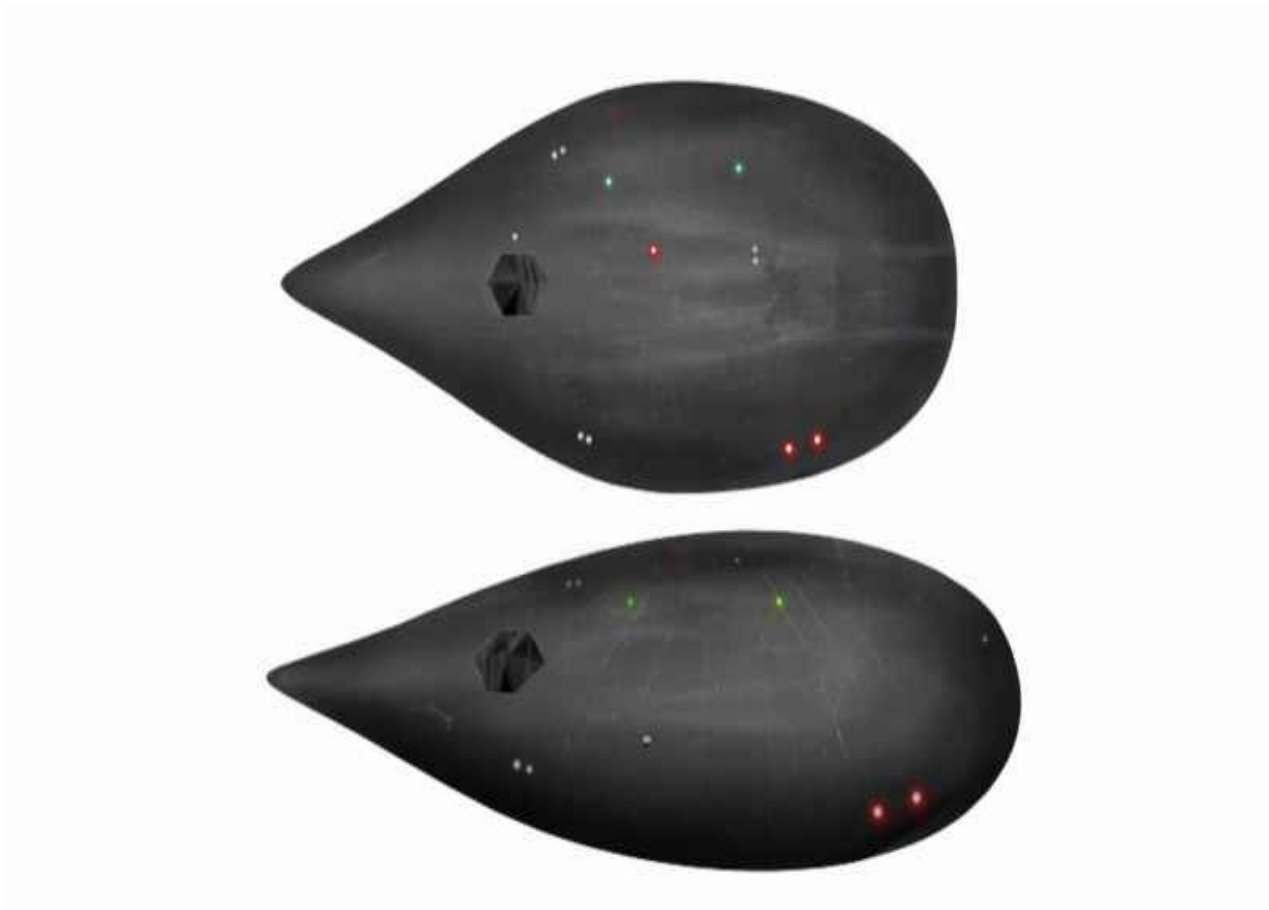
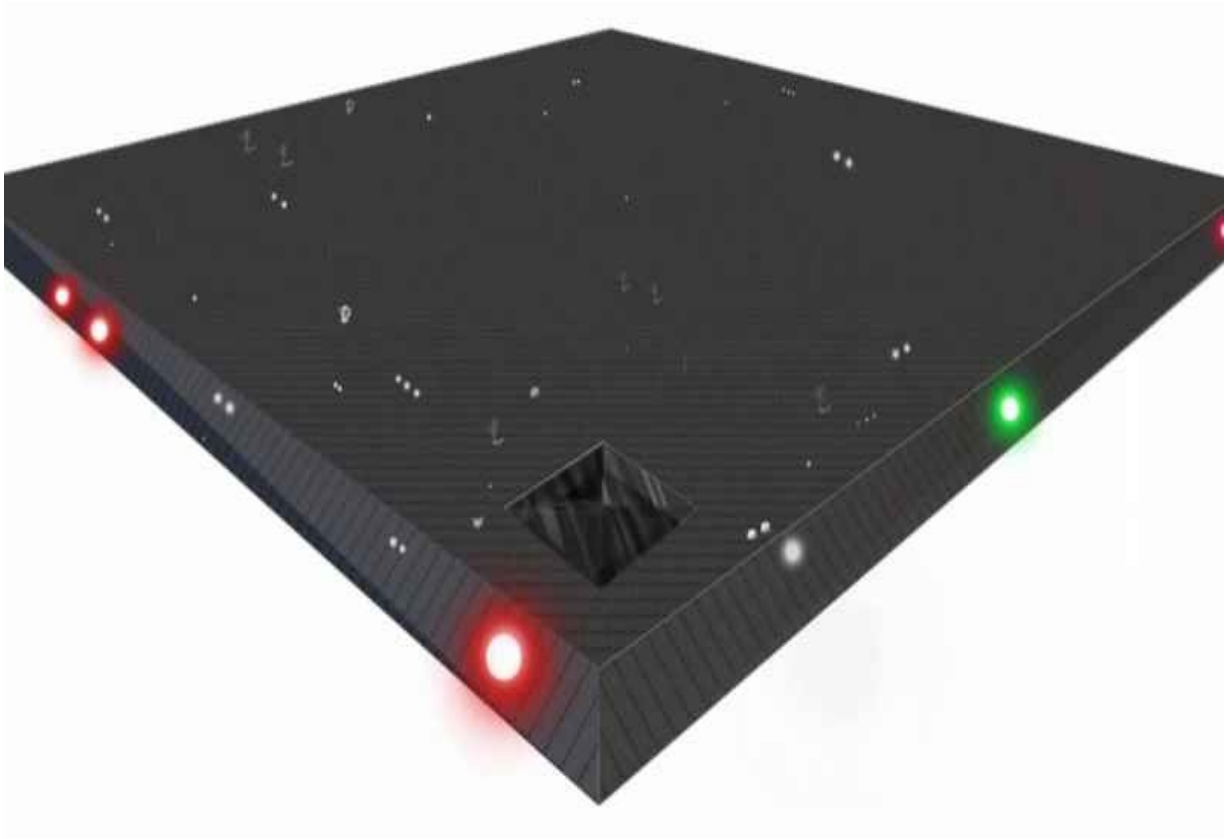

They have a very large pumpkin seed-shaped vessel.

David: When you say 'very large', now, what are we talking?

Corey: Over 600 feet [183 meters] across.

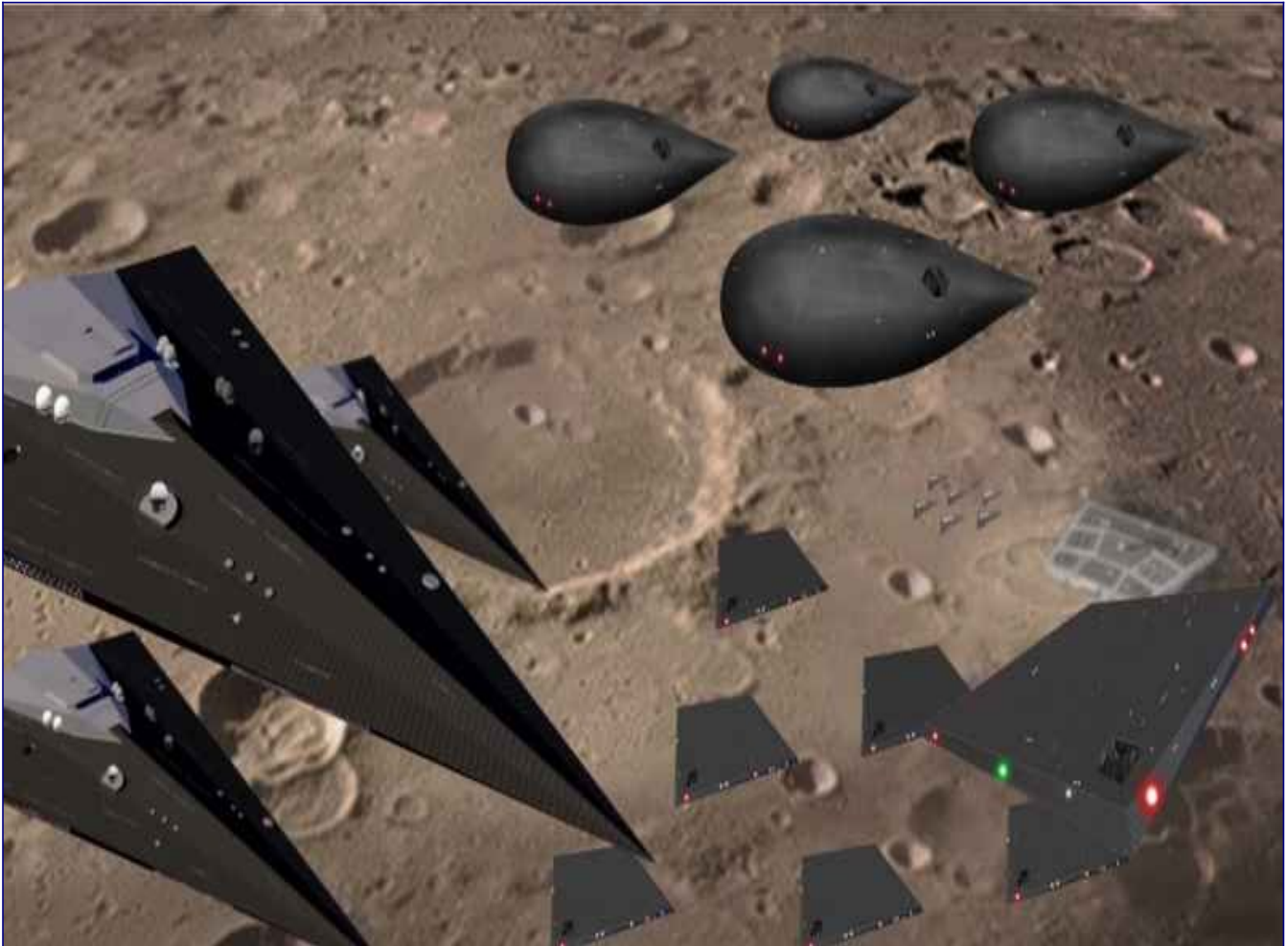

David: Okay.

Corey: But those are smaller than the large wedge-shaped vessels.

David: Right.

Corey: And all we've really known about them is that they fight . . . They're an offensive force. They are for going and doing offensive type of work alongside the Draco. They go outside the solar system on, I guess, conquests or defending Draco territory, helping the Draco on military expeditions.





David: Yeah, and you have an illustration of that we can bring up here.

The ICC has helped them build out a lot of this, these vessels and weaponry. And then the Draco group has helped them enhance it even more so for offensive duties outside of the solar system.

And they spend almost all of their time completely outside the solar system, and we hadn't received . . . We knew of . . . There's one of their bases on the Moon that is quite a ways from the Lunar Operation Command that is shaped like a pyramid with the top chopped off.

Corey: Yeah, that's not my illustration. She needs full credit for this image. She had been abducted and taken to this facility. I was very surprised when people wrote me, and someone else had described this same facility on the moon.

David: And it looked exactly like what you saw.

Corey: It looked almost exactly, pretty close, but it's a very good representation. And it's been almost impossible to get good intelligence about what's going on there.

The Dark Fleet is completely human-ran. They do answer to and work alongside the Draco Alliance. They're allies, and they go out and they do offensive battles and offensive expeditions together outside the solar system.

David: What are they going for? What is the offense about? What is the goal or the objective?

Corey: We assume that it's conquest or keeping certain areas secure or reined in in their empire, but we really don't know. It's been very difficult to get information and intelligence about the Dark Fleet. And there's been a few defectors from the Dark Fleet that were stuck inside of the outer barrier that was erected. Most of the Dark Fleet was stuck outside.

And whatever information has been gleaned from those defectors, I have not heard. So they have been a very large mystery to a lot of people.

David: Why would anybody want to cooperate? Why would any humans from here want to cooperate with these reptilians that are basically like biblical demons or devils?

Corey: Well, one person's demon and devil is another person's god.

David: Sure. So we don't really know exactly what they're doing out there, but you said that when this outer barrier went up, a lot of them got locked out of our solar system.

Corey: Yes.

David: But it appears that a significant portion of their command structure, their elite, were actually in our solar system when the barrier went up?

Corey: Yes. Yeah. Command and control, and communications were still here, and a lot of their operational forces were outside doing what they do when this outer barrier was raised. So they became stuck outside of this field around our entire solar system that is way, way out past where the heliosphere is - out past the Oort cloud. It's huge. And they can't come back.

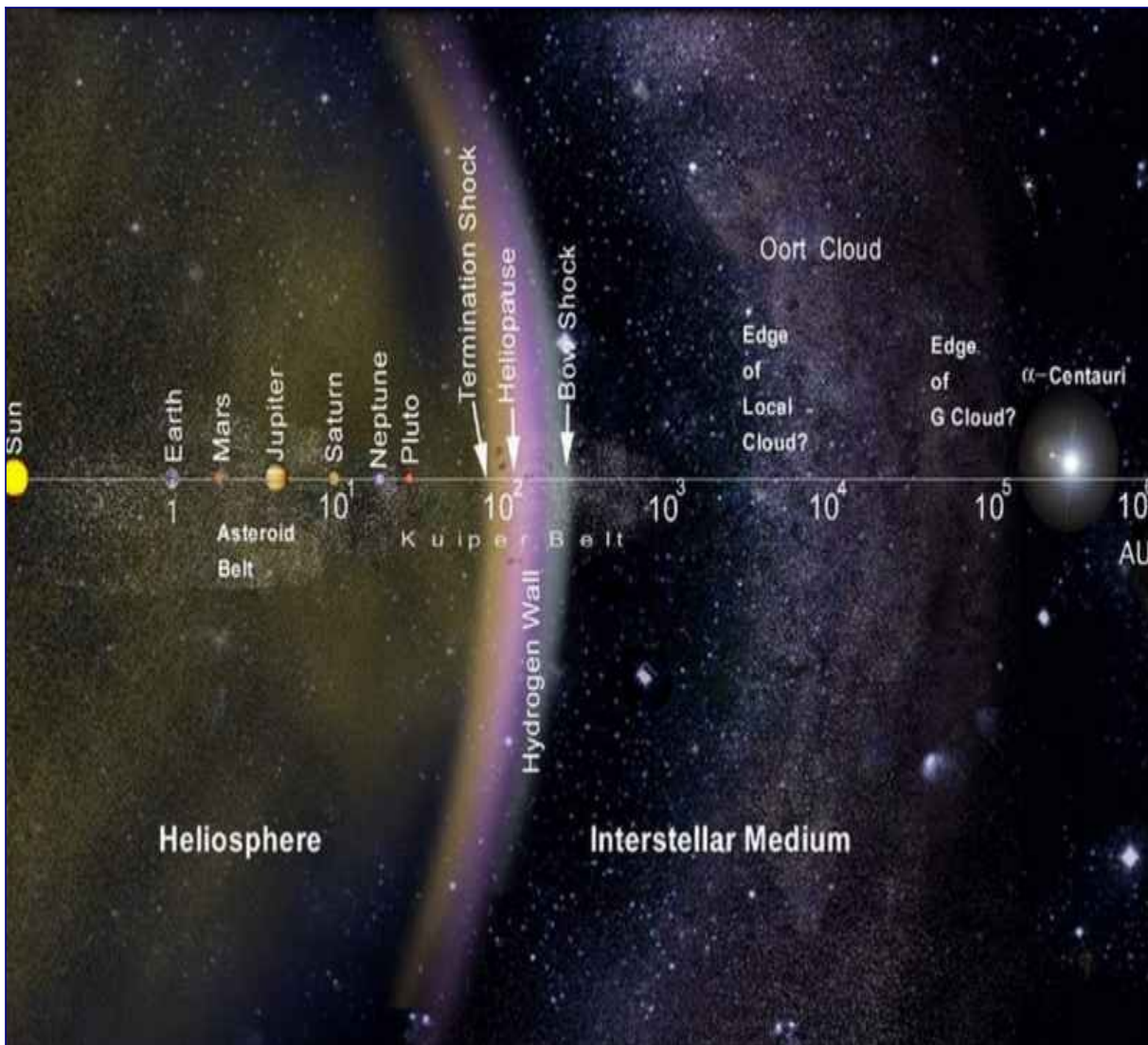

So the structure that was here has somewhat been cannibalized into the ICC and defected to the Alliance.

David: If you saw somebody from the Dark Fleet, what are they going to be dressed in? What do they look like?

Corey: They were very distinctive. A lot of the times they usually . . . It's almost out of "Star Wars" again. They wore . . . They had a very . . . They looked very stern, very arrogant, like they felt very elite. They wore black stormtrooper kind of clothes, just very stern like. Very totalitarian acting. And a lot of the people that ended up going into this program came from a lot of the German secret society Nazi kind of programs.

A lot of them and their ancestors or people that were born later on after these breakaway civilizations occurred have joined.

David: So do these Dark Fleet personnel actually . . . Do they have homes here on Earth? Do they go out to work? Do they drive into a local military base and portal out?

Corey: I would assume that they are 100% vested off-world.

David: The way you're describing it, it sounds very military. I'm wondering is it all men, or are there women in the Dark Fleet, too?

Corey: I'm sure there are women, but I personally only saw men.

David: Hmm.

Corey: Yes, they're very regimental, very totalitarian, very . . . The energy you feel from them is very unnerving. They don't feel like pleasant people at all.

David: Are there different races of normal humans that we'd see on Earth in the Dark Fleet?

Corey: Yeah. It's not a Caucasian purity kind of . . .

David: Really. Okay. You mentioned that the Draco have different reptilian types, and you said there's insectoids as well. Did they co-mingle with these humans in the Dark Fleet, or is the Dark Fleet simply a human fleet that is a support crew for the Draco Alliance?

Corey: They are their . . . It's a human, completely human, fleet that flies in support of and alongside the Draco fleet.

David: So you don't . . . You're not going to see extraterrestrials on these ships.

Corey: I don't think so. I've heard people talk about advisers, maybe one or . . . some advisers being on board, but this is like second, third-hand information that I've heard people talking about. There's a lot of mystery about . . . That has been so compartmentalized about the Dark Fleet. That is one of the biggest secrets still remaining even with those in the SSP Alliance unless there's information they haven't shared with me recently that they have found out.

The Dark Fleet had a lot of secrets.

GLOBAL GALACTIC LEAGUE OF NATIONS

Corey: And then we have this Global Galactic League Of Nations group that was somewhat of a carrot that was offered to all the other nations to have them maintain this veil of secrecy about what was going on in outer space by giving them a space program and giving them a narrative of “There's certain threats, or possible invasions, we need to come together and work together.”

And at the one facility that I visited a couple times, it looked very much like the TV show "Stargate Atlantis" where you had a real laid back environment, people walking around in jumpsuits with patches from all different countries off the world. They are almost completely outside of the Solar System as well.

This program was a fairly recent one. It didn't start back in the '50s and '60s.

David: Oh.

Corey: Back then is when they started to find out what was going on.

David: Okay.

Corey: I believe this was something that started probably, at least, in the '80s maybe even '90s. It's fairly recent.

SSP ALLIANCE

David: Where does the Alliance come into play now that we're talking about the Solar Warden? You said Solar Warden got started in the late '70s and they got a lot of the “Star Wars” technology?

Corey: Mm-Hm

David: How does this relate to the Alliance exactly?

Corey: Okay. Well, that . . . They were kind of the root group that formed the Alliance. Now, they're made up of breakaway or defectors from the other space fleet groups.

Yes. It was on the brink of that when the Sphere Alliance, the Sphere-Being Alliance, went into an active mode and made contact with the Alliance . . . the Secret Space Program Alliance, which had just

started accepting defectors from some of these other group to where it wasn't just the Solar Warden group anymore.

The Alliance was made up of defectors from the other programs, as well. So, it's a hodgepodge of defectors from all the space programs that have a common goal of ending the tyranny on Earth of basically the secret Earth Government that controls the "Babylonian money magic slave system" and to bring to Earth the technologies that we have developed that has free-energy, all kinds of medical technologies that will heal just about anything you can think of, clean up the environment. Overnight, these technologies would collapse the financial system and there would be no need for a financial system. And they want to bring this to Earth and to also do a full disclosure of all of the crimes against humanity that all of these elites have been doing over many, many years. That's their goal.

David: So, when did the Secret Space Program Alliance start to have these goals in mind and begin to take action on them, to your knowledge?

Corey: To my knowledge, they started forming these ideas in, probably, the late '90s and were really starting to act on it in the early 2000s, where they were really trying to cause accidental disclosures by flying in front of live (video) feeds, trying to get people to ask questions.

EARTH ALLIANCE

David: Is there an opposition going on to the Cabal that goes beyond bloggers?

Corey: Absolutely. Every single enemy they've created over the hundreds of years, every group they've alienated, every atrocity they've done to these countries over these hundreds of years, has finally built up to a point to where they all came together, loosely came together.

All of them have their own cultural pains, and I guess some of them have different agendas on the retribution they would like to see exacted on the enemy, which we're calling the Cabal. Others would like to just maybe have a few changes. They think a world government is inevitable anyway, and the Cabal was wanting to do it in an evil way, so why don't they co-opt it and do it the right way?

Despite many of these alliance groups having different agendas and ideas about what should happen to the Cabal once they overcome them, they've put aside a lot of differences, and they've come together for a common goal, which is to defeat the Cabal.

And this is the key of why the Cabal had been so successful. They are made up of many different syndicates of people with many different belief systems and agendas, but somehow they found a way to work together. The 0.01% of them have found a way to work together, even though a lot of them really don't like each other, to exact control over the Earth.

Well, the Alliance is following the same playbook, getting together with people they wouldn't normally work with, forming a loose alliance, and trying to, or actually are in the midst of, overthrowing the financial system that this Cabal has set up for the last 100 years and want to replace it.

David: So I think people that are investigating this have felt that the Cabal controls central banking in every country. They have bribed or compromised all of the leaders in every country. The leaders are blackmailed, and therefore even people who are fairly compassionate and reasonable folks, there's a widespread belief that this Cabal has just penetrated every country, all aspects of society. So what do you say to those people when they hear about the idea of an alliance and they, "I just don't believe it?"

Corey: Well, there is an Alliance, and it is true that this Cabal is a master at infiltration, and, indeed, they have infiltrated elements of the Earth Alliance. And, you know, this is a problem, but, like the BRICS Alliance . . .

David: You're talking Brazil, Russia, India, China, South Africa is the B-R-I-C-S.

Corey: Right, they've gotten together, and they've created pretty much a new world bank and financial system to compete with the Western or Cabal banking system.

David: And you're talking about the Asian Infrastructure Investment Bank, or AIIB.

Corey: Right. Over time, countries like China have been slowly purchasing the debt and also natural resources from countries owned by the Cabal as their financial Ponzi scheme has slowly, slowly started to collapse.

THE DRACO ALLIANCE

Corey: There are a wide range of different types of reptilian beings that are involved with this Draco Alliance, but there are also some insectoid-type beings that are involved in this Alliance and some very strange Nordic-type beings.

There's been a little bit of information that they are a conquered race that was forced into servitude, but that are also a part of this federation.

David: Well, let's start with some of the basics, which would be if somebody were unfortunate enough to see a Draco, what are they going to see? What are we talking about here?

Corey: There's many different types.

David: Okay.

Corey: Yes, but they're bipedal. They have different types of reptilian beings, some that are quite short in the 4 ½ to 5 feet tall that look very much like Greys. They have reptilians that are of like the Draco-type that are . . . They range from 9 to 14 feet plus tall. And there's a whole range of them.

They have different castes within their system. They have like a warrior caste. They have engineers, scientists, almost like a hive. And then they have their royalty up at the top that control and direct everything.

David: If you were to see a Draco royal, what are you going to see? What's the height? What are the characteristics? What do the eyes look like? What does the skin look like? Let's just get into that.

Corey: Well, I met, unfortunately, a Draco royal, and it's not . . . it's something that I've refused to repeat and so has Lt. Col. Gonzales. This one was around the 14 foot [4.26M] range, which is incredibly tall. They are incredibly muscular.



David: They couldn't even stand up in a typical room that any of us would have.

Corey: No. Very reptile looking, had vestigial wings and a vestigial short tail.

David: What do you mean by 'vestigial'? What are you saying it is?

Corey: Like the wings at one time would have been able to support them in flight, but now they are just a remnant.

David: So they're just stubby little . . .?

Corey: Right. They're kind of a remnant of what I was able to see unless they were triple-folded in a way to where they could have opened up wide. I mean, it just looked like vestigial wings.

David: When you see this white being, does it wear any clothes, or is it basically just naked with its scales – white scales?

Corey: Yeah. It was not wearing clothing.

David: Okay. And you have said before it has a very ripped muscular look to it?

Corey: Yeah.

David: Now, my other insider said they weigh 3,000 lbs. [1,360 kg.] and have a 5-foot-wide shoulder span. Would you say that's correct?

Corey: The weight . . . I would say, yes. That's probably close. 5 feet for the shoulder span – I don't know if that's even enough.

David: Really?

Corey: Yeah. Very broad, very intimidating.

David: Are they all white? Or is this just one type?

Corey: No. There's another type that people describe as red, but it's a real weird brown that makes it look red that also has wings. They're smaller, and they're less muscular, but they're . . .

David: Now, these folks have the vertical slit pupil, right?

Corey: Mm-Hmm.

David: And the eyes are kind of large on the face like a Grey, or is that not so much this type?

Corey: No. It's in proportion to its skull as you would picture a reptile.



David: And there's just two holes for the nostrils or not really a nose?

Corey: Well, it depends on which ones you're talking about. Yeah, they have nostrils that will sink in and go up, and then there are some of them that have sort of a nose that goes up . . .

David: Like a snout.

Corey: Kind of like a little snout.

THE SPHERE-BEING ALLIANCE

Corey: They do not call themselves the Sphere-Being Alliance. This is a term that the Secret Space Program and some of the secret Earth governments gave them. They call them the Sphere-Being Alliance, because they were able to gather, through intelligence, that it was a group of beings that were associated with these giant spheres of three different sizes, the Moon, Neptune and Jupiter, that were

now in our solar system for reasons they were not sure why they were there.

But this group was not making contact with them. They were ignoring their hailing attempts to communicate with them. So this is just what they named them early on.

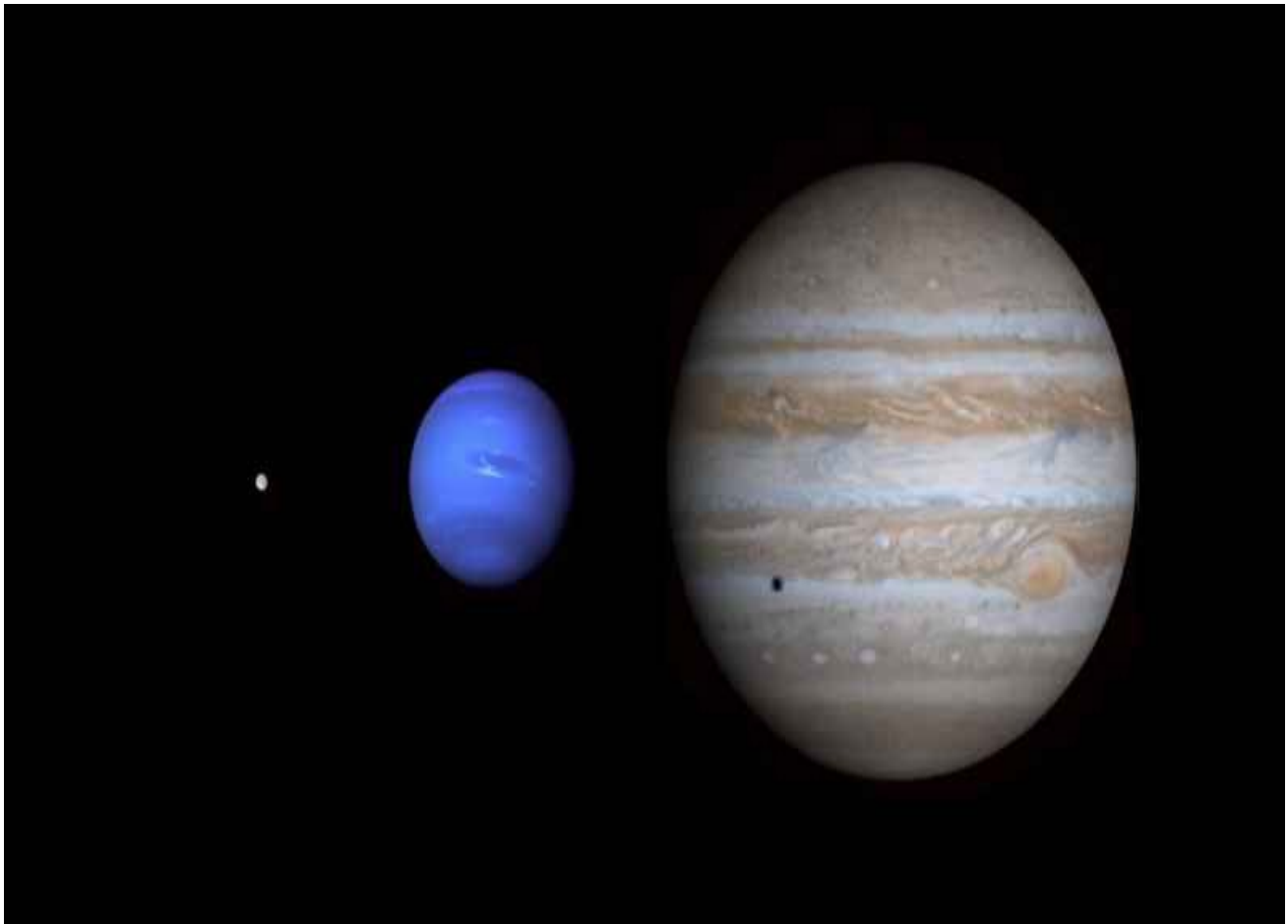

LIFE AFTER DISCLOSURE

David: What would the average person's life be like if the Alliance's goals are met on Earth? What would that life be like?

Corey: It would be no different than the “Star Trek” era - what you've seen in “Star Trek”.

David: So could people have a portal station that they could go to, where instead of flying through the airplane that you'd be able to take some kind of stargate-type system to wherever you wanted to travel?

Corey: Sure. Yeah. There's replicators. There would be no starvation. Literally, the deserts could be turned green with desalination of water.

David: What about all the plastic floating in the ocean in these big giant gyres of waste material?

Corey: Matter is easily changed into something else. It's just a matter of knowing how, the technology to do so. And we have that technology. It's just not being shared.

David: Some people might be really freaked-out by the idea of not having money anymore. They're going to say, "That's socialism. That's communism. That's going to get us under even more control because nobody will have any money to resist this new thing that they're trying to do."

Corey: That's the way we're programmed.

David: How would you think that that's not the case?

Corey: I mean, if you want money that badly, you can use a replicator and replicate some silver or gold or replicate yourself a \$100 bill, if it makes you feel comfortable, and put it in your pocket. There will be absolutely no need for any type of financial give or take.

David: I would think that the typical old-school politician mentally would be that if you gave everybody on Earth this kind of stuff, that they would all just want to drink beer and nobody would want to do anything, and they'd just be hanging around and it would kill them. It would ruin their lives.

Corey: Well, there's going to be a transitional period where people are going to go probably a little bit nuts for a while with the technology.

David: I mean when people win the lottery right? It's not good for them.

Corey: Right. Well, if everybody wins the lottery at once, everybody has a replicator. Everybody's going to be pushing the button every day and trying all these different meals. Everybody is going to want to go all over the world, and once it's cleared all over the solar system, and see all these different ruins that are everywhere. I mean there's going to be a lot that's going to be opened up. But first, we're going to have to go through the process of dealing with our past and getting over our past.

David: All right. Well, I hope you enjoyed that as much as I did. This is awesome stuff. When you start to get it all together like this, as I'm sure you can feel now, the scope of this information, the awesomeness of what there is to know, how much we've been lied to, and the incredible world that exists all around us veiled from our view so thinly that we now have people like **Corey** coming forward, and others, blowing the whistle on this, telling us the truth, bringing us the knowledge that

you need to help your mission and my mission of freeing this planet from the tyranny that has held us under for so long.

We look forward to another year coming up of even more amazing episodes like this for you to enjoy with us as we both go on this journey of exploration and discovery together.

This is [David Wilcock](#) and the Gaia network, and I thank you for watching.

Coming up soon, we're going to have explosive new episodes of **William Tompkins** and Sergeant **Clifford Stone**. **Tompkins** is an aerospace engineer whose testimony validates many aspects of what **Corey** has been saying on "[Cosmic Disclosure](#)".

And Sergeant **Clifford Stone** specialized in UFO crash retrievals, firsthand identification of the extraterrestrials, both alive and dead, from these wreckages.

That's coming up here very soon on Gaia.

[Cosmic Disclosure: SSP Testimonials with William Tompkins](#)

Season 5, Episode 10

William Tompkins: So I went to work, then, at Douglas, and I'm a draftsman for two weeks, and my Section Chief started through my background.

And, of course, it says all of this stuff that I had done in the Navy. So he puts me in this think tank, and there is where we get to the first think tank, okay, - was inside of Douglas in a walled-off area.

And there's 200 guys in it.

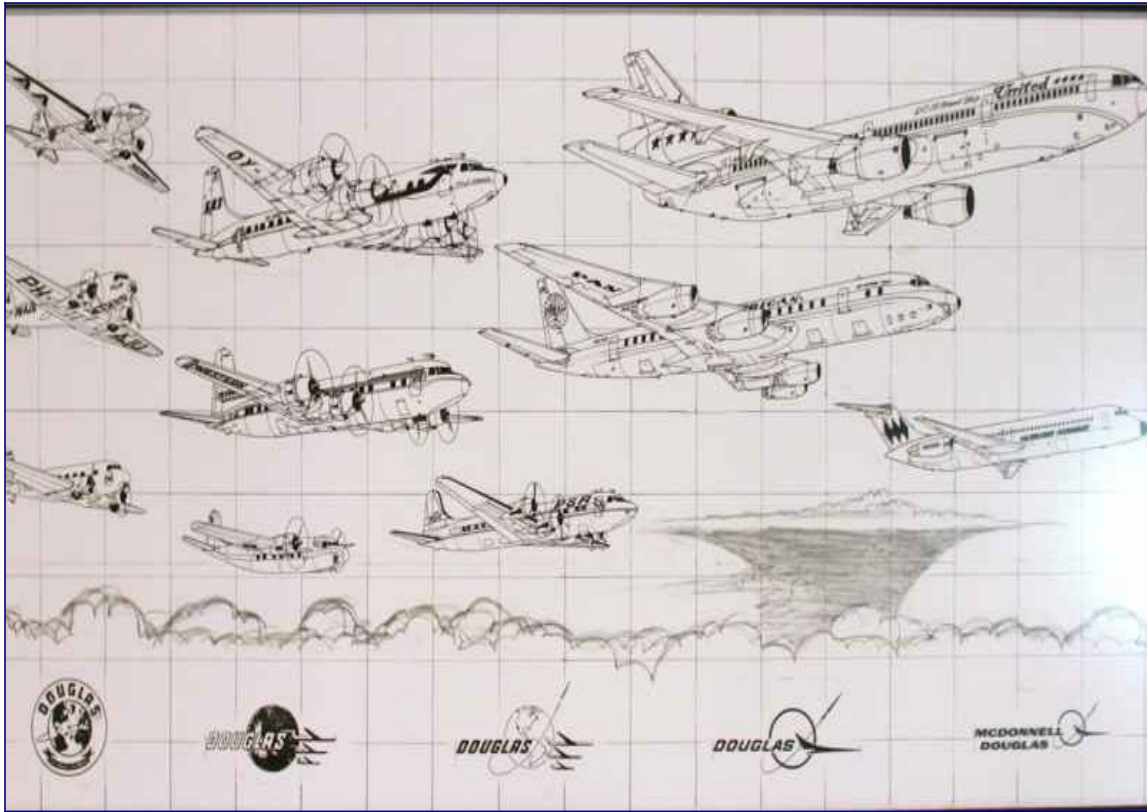

CV/PHE:hg/vc

19 May 1945

To: All Bureaus, Boards and Offices of the Navy Department
The Commandant, U. S. Marine Corps
The Commandant, U. S. Coast Guard

Subj: Office of Research and Inventions.

1. There is hereby established, in the Office of the Secretary of the Navy, the Office of Research and Inventions at the head of which shall be a Chief and an Assistant Chief, appointed by the Secretary of the Navy and designated, respectively, the Chief and the Assistant Chief of Research and Inventions. In addition to reporting directly to the Secretary of the Navy, the Chief of Research and Inventions shall also report to the Chief of Naval Operations. The orders of the Chief of Research and Inventions shall be considered as emanating from the Secretary of the Navy and shall have full force and effect as such.

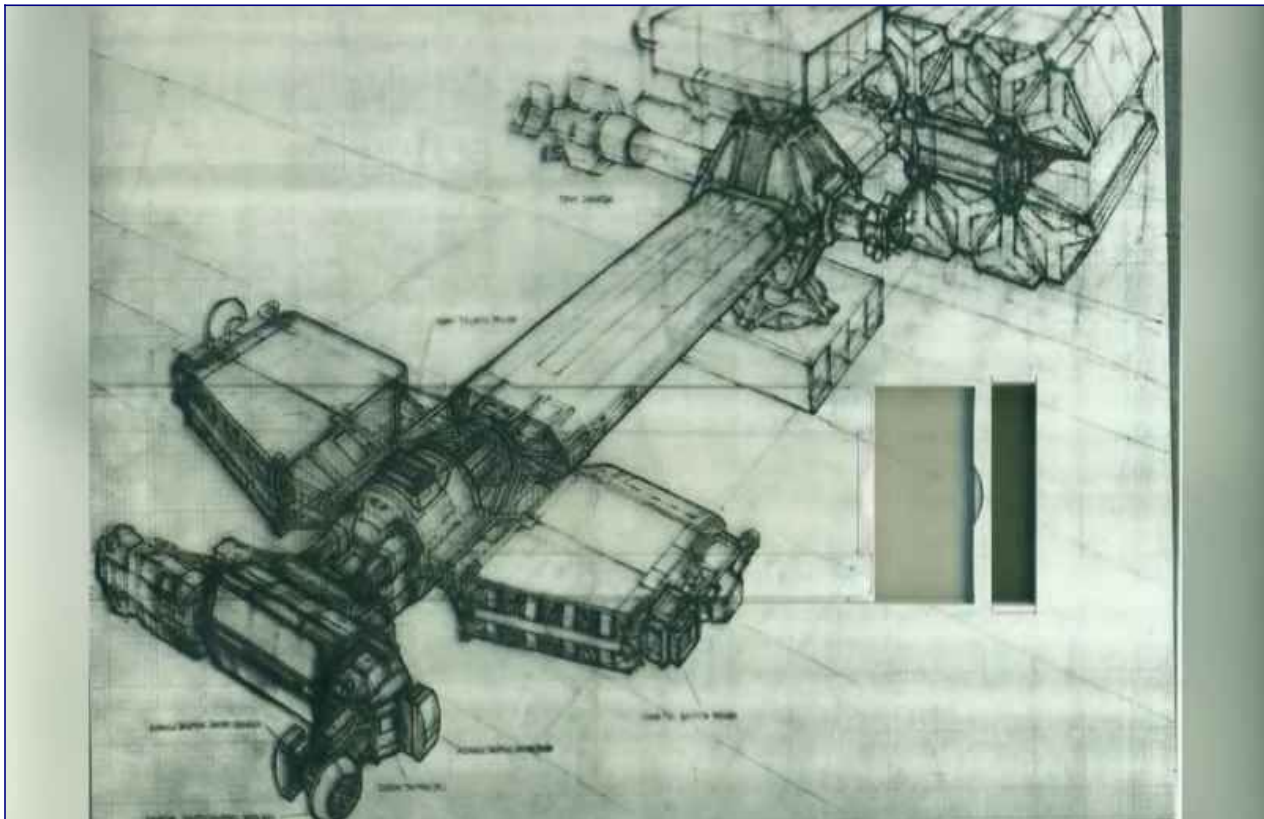

And we investigate every aspect of extraterrestrial - military, commercial, whatever. And I was assigned to design for the Navy about 16, 18 different classes of US Navy battle group ships, which didn't exist.

And these were . . . The larger ones were from 1 kilometer to 6 kilometers.

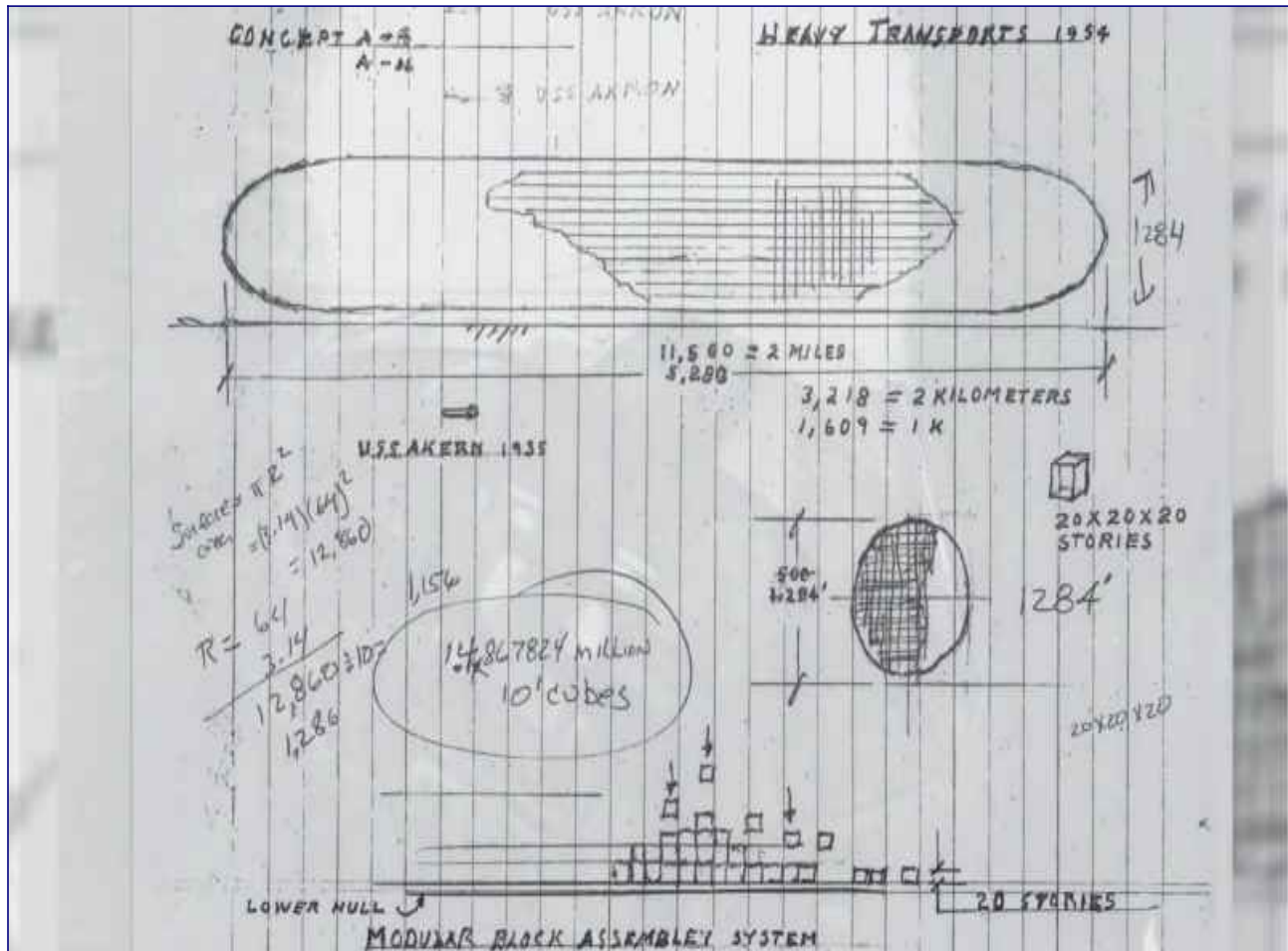

These ships fly in space. They're spacecraft carriers. I designed US Navy Spacecraft Carriers, which finally got built back in the late '70s up in Utah, underneath the ground.

And you've seen the pictures of US Navy spaceships – Solar Warden. So Solar Warden came out of a think tank inside of Engineering at Douglas.

And a whole lot of other stuff came out.

David Wilcock: All right, this is **David Wilcock**, and you are watching [Cosmic Disclosure](#). I'm here with **Corey Goode**, and in today's presentation we have a bombshell for you. We're going to be interviewing the veteran insider of the Secret Space Program, **William Tompkins**.

I've had numerous conversations with him. He's actually 94 years old, he's still with us, and his testimony is unbelievable. It validates so many aspects of what **Corey** and other insiders I've spoken to have been saying.

People tell us, "Oh, you have no proof. You have no evidence."

Well, here's a guy who comes out of the World War II era, and his testimony is just going to rock your world.

I want to give you a little background, biographical information on him to set this up. So check this out.

William was first noticed by the United States Navy when he was just a young boy. He was living near Long Beach, California at the time, and his father would take William and his brother down every weekend to see many Naval ships that were parked in the harbor there at Long Beach.

William Tompkins was a good artist and he was really good at building models.

And soon, he started creating scale models of the ships he was visiting.

The Navy began taking notice of this brilliant young boy and his models because they were so close to the real thing.

But it was when young Bill **Tompkins** began adding top secret parts to these model ships that the higher brass took real notice of him.

He was then taken into the Navy and was brought into a think tank during World War II.

After the war, he went to work for Douglas Aircraft, which is now the defense contractor McDonnell Douglas.

If you want more information on **William Tompkins's** fascinating background, I encourage you to go to the biographical introduction on **William Tompkins** that we have here on Gaia.

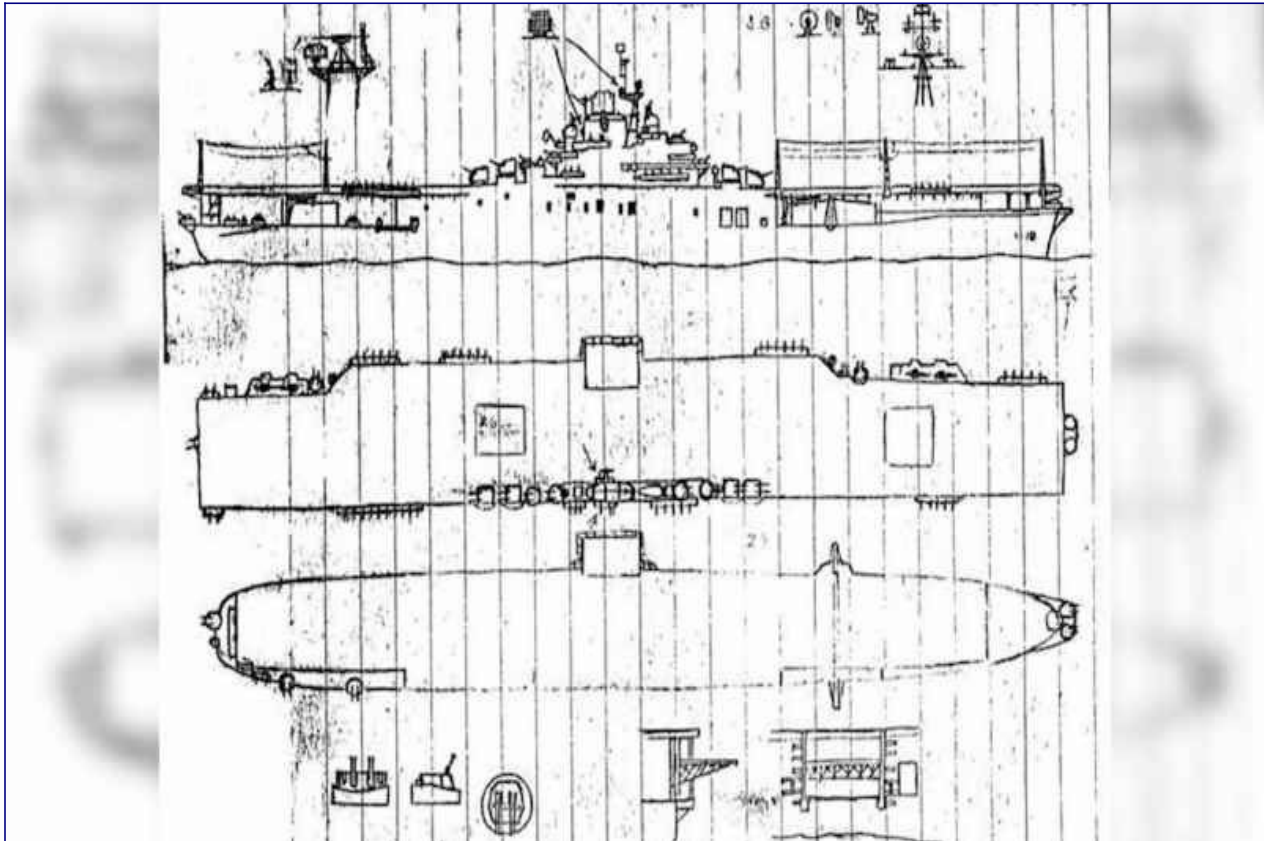



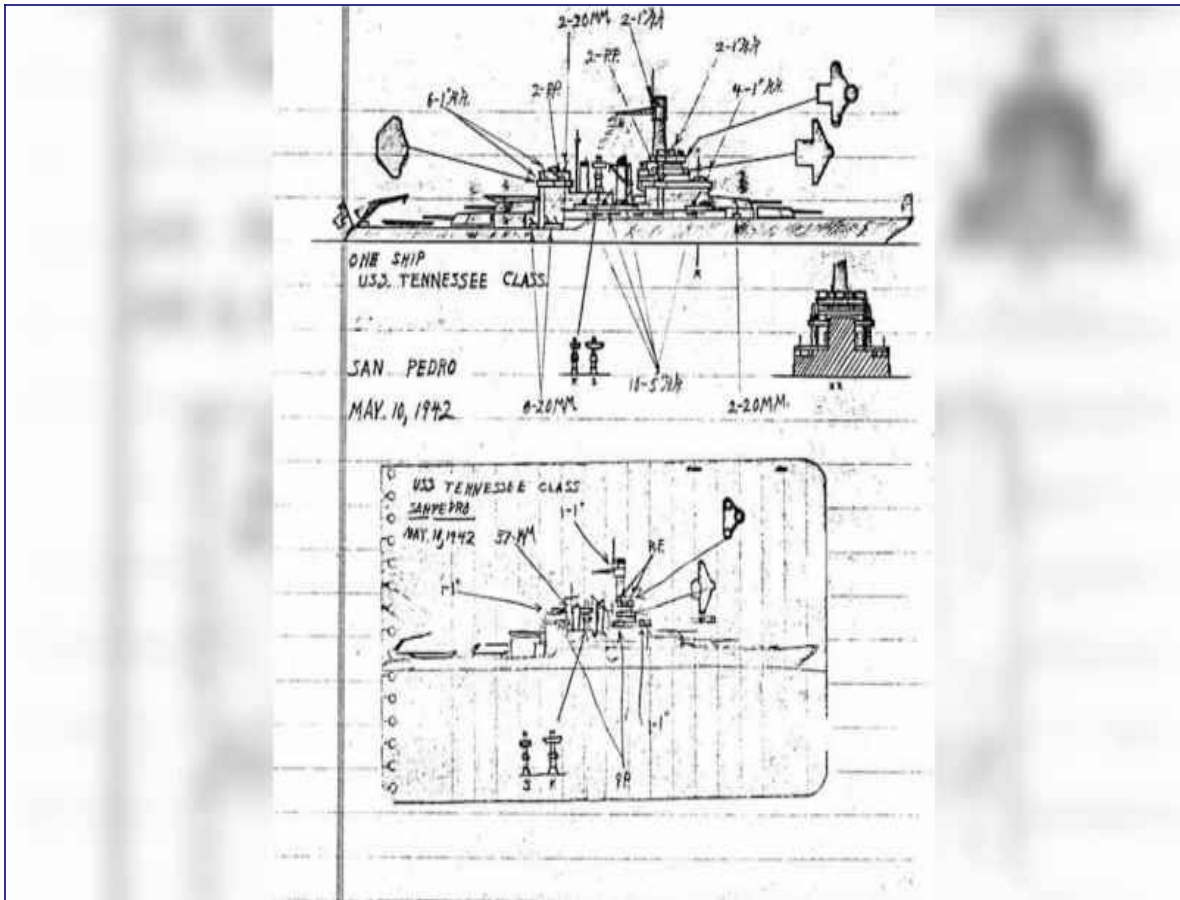

Douglas Engineer Adds Airplanes to Hobby

So realistic is the hobby of William P. Tompkins, 28, that naval authorities prior to World War II cautioned him for possession of restricted Navy staff blueprints.

Tompkins, now a Douglas Aircraft engineer, did not have Navy blueprints, investigators learned, but did possess an uncanny accuracy for detail with which he has built a fleet of 61 Navy warships.

TINY SHIPS

The miniature fleet ranges in size from an 18 1/2-inch replica of the carrier Lexington to motor launches 1 1/4 inches in length.

Principal material used in construction of the intricate models, Tompkins yesterday explained at his home, 204 1/2 21st street, Santa Monica, is balsa wood carved with a razor blade.

Sheet aluminum, glass, wire and needles are used for such things as gun emplacements, lifeboats and airplane wings.

Tompkins began his shipbuilding hobby at 16, and today can build the less complicated ships in six weeks. The Lexington model took six months.

NAVY PILOT

A Navy pilot during World War II and a graduate of Hollywood High School, Tompkins has been using his model-building skill to produce wooden reproductions of future airplanes. Recently he was transferred to

THE FLEET ARRIVES—William P. Tompkins, 28, Navy pilot during World War II and now an aircraft engineer at Douglas

plant, displays part of his fleet of 61 warships. He also models airplanes as part of his hobby. Navy ships vary from 18 1/2 to 1 1/4 in. in length.

San Bernardino Telephone Users Reach All-Time Peak

SAN BERNARDINO, Feb. 5.—[commodate the growth of local telephones served by the San Berni a new store room garage an

GET N

San Bernardino Wholesale

RAY BENOIA is the most efficient since its founder took a every five days a new job. Benoit cap pose of the signed "to be supervision, t greater effie broader depu orientation of area."

In most case are shifted, the transfer from in Valley suburban change within in the month W. Carollan, shifted from 1 stow.

AT TOP LEI

In top level Ethen becomes detective in th litigation; L. J. is the new chief trative intelligence Inspector H. I responsible for deputation, comm line, the 3rd previous operatio Capt. Lester J at the new di training with 1

William Tompkins became part of a secret think tank that began to design the ships, the craft, the buildings, and everything they would need for the Secret Space Program.

But we want this to start out with a bang, so we're going to begin by joining **William Tompkins** as he tells us of his many decades-long journey through the Secret Space Program.

He's going to start out our conversation by telling us how the US Navy began discovering some of the things that the Germans had been inventing since the early 20th century.

GERMANS IN SPACE

Tompkins: It's '42 – 1942. The war's on. Rico Botta, his hobby is sending these Navy operatives into Germany. They've been going all over Germany, and they're staggered at what they've found.

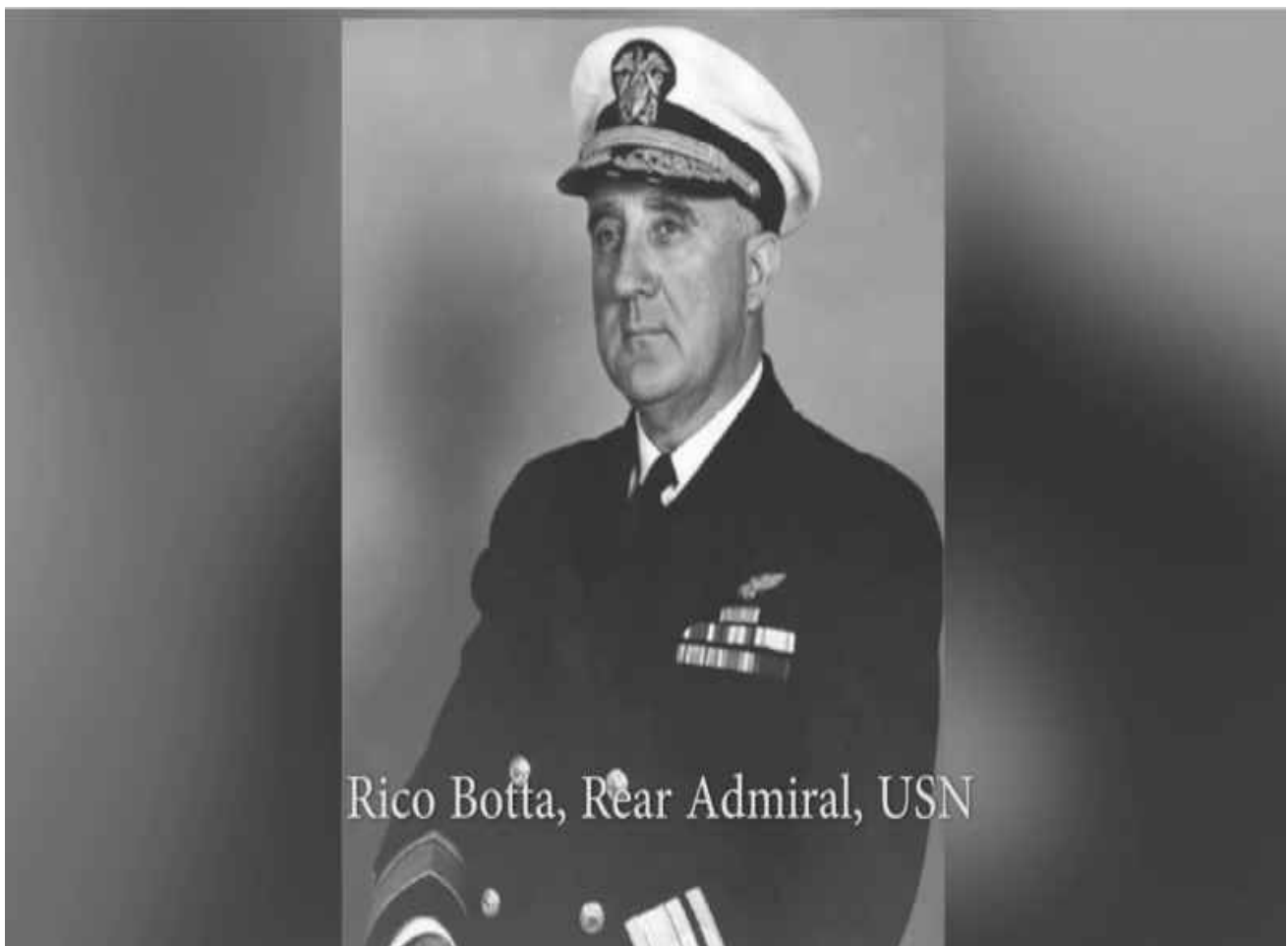

They found that Hitler and the SS made an agreement with reptilian extraterrestrials.

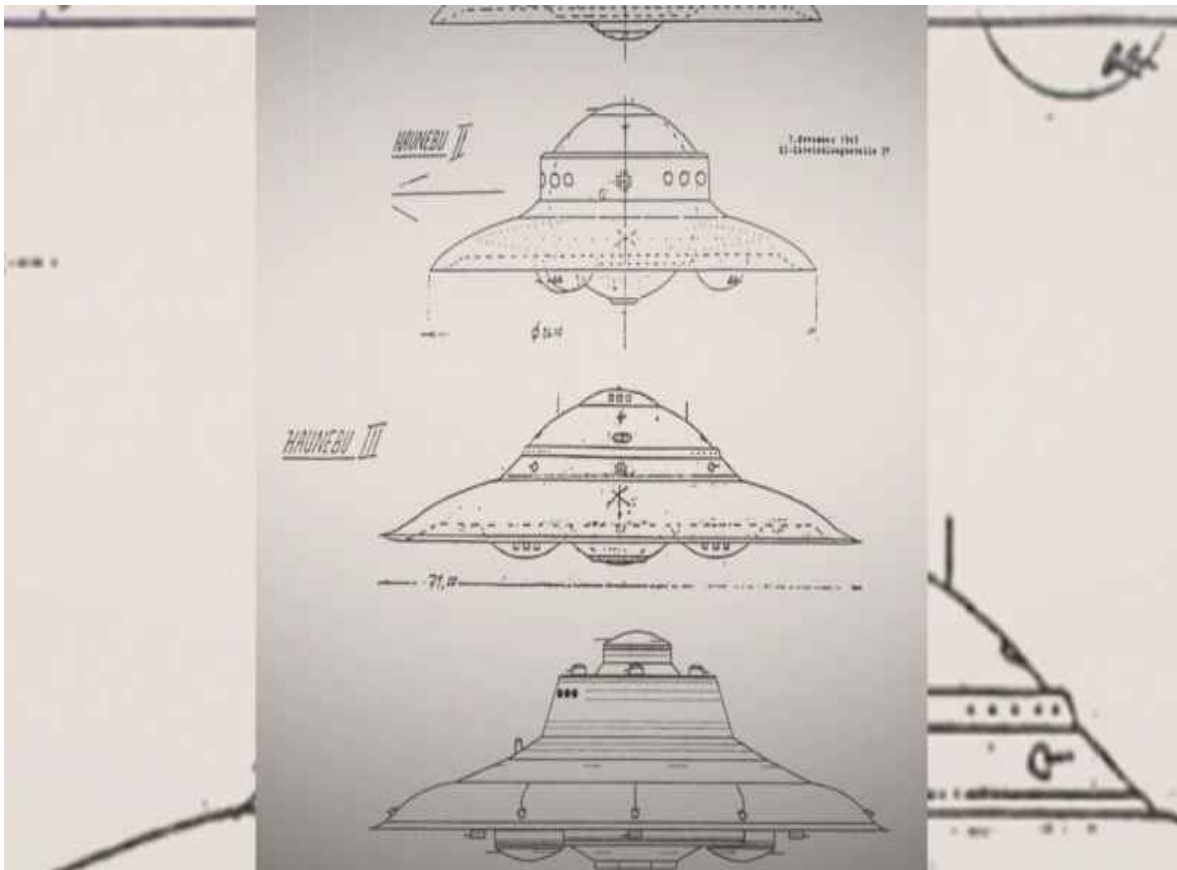



They found hundreds of different types of advanced weapons being built.

These included 60-foot and 250-foot, 500-foot UFOs – round vehicles, okay? UFOs.

They built some of these out of chromoly steel that would weigh tons and tons and tons.

They had developed, or they had been given, electromagnetic anti-gravitational propulsion by the reptilians.

The agreement turned out that they were to develop a parallel space Navy that the reptilians had and operate out through the galaxy, with the reptilians taking over planets, enslaving the people on the planets.

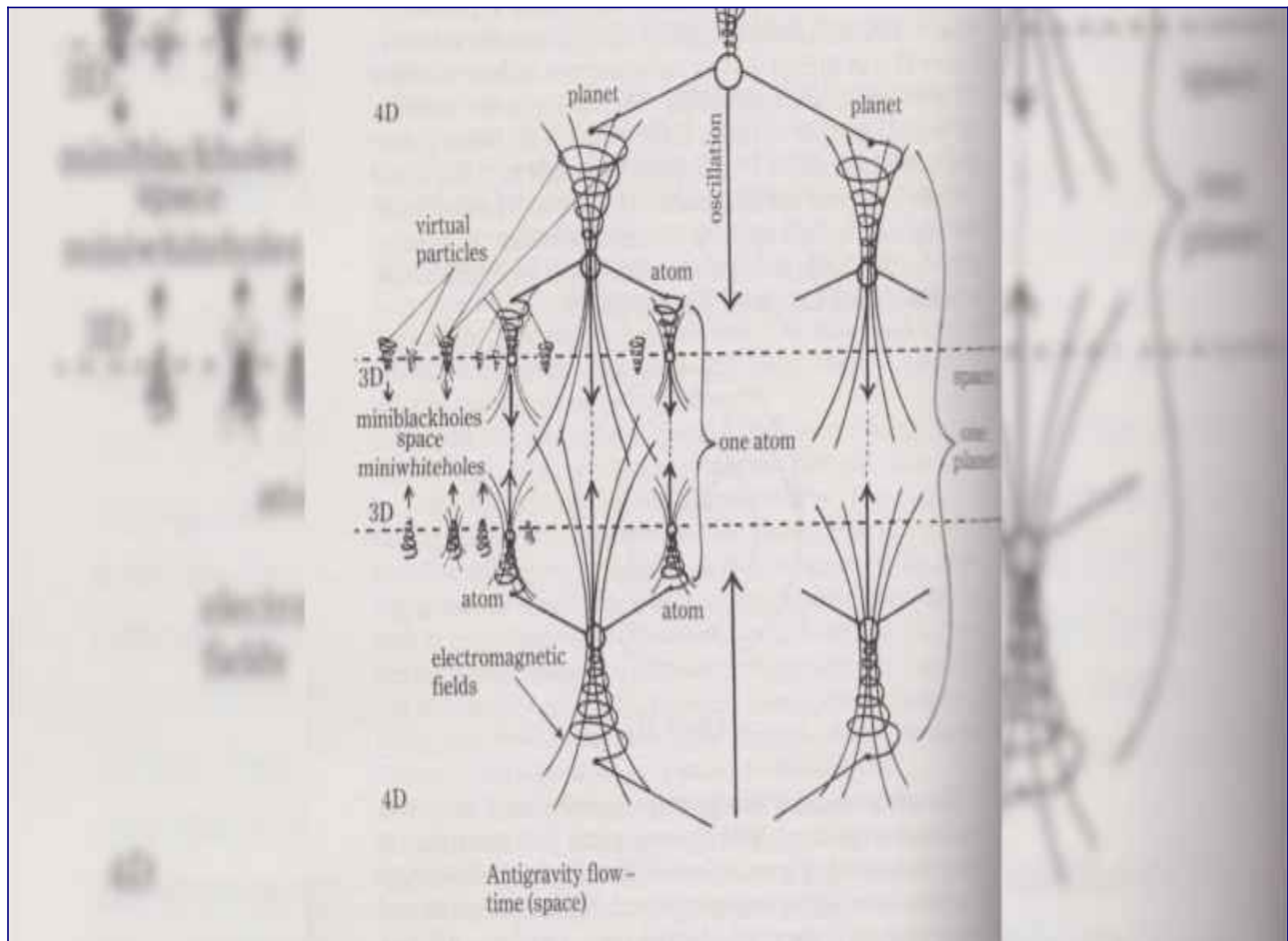

But what they had already accomplished was really strange.

44

Flugkreisel-Erprobung, Stand / Anzahl Erprobungsflüge:

HAUNEBU I (vorhanden 2 Stück)	52	E-IV
HAUNEBU II (vorhanden 7 Stück)	106	E-IV
HAUNEBU III (vorhanden 1 Stück)	19	E-IV
(VRIL I) (vorhanden 17 Stück)	84	(Schwanz)

Empfehlung:

Beschleunigen von Abschlusserprobung
und Produktion „Haunebu II“
+ „VRIL I“

HAUNEBU I

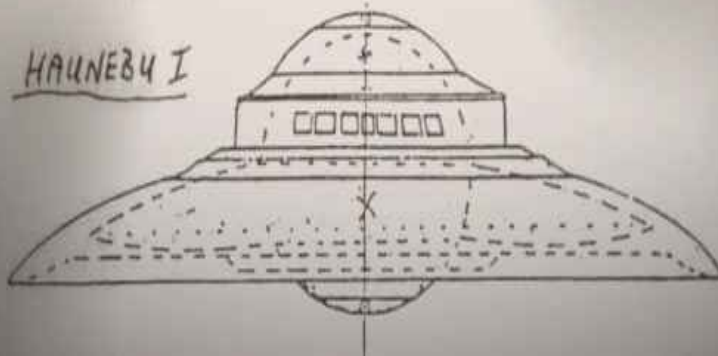

They have all these UFOs, different types of propulsion that were unbelievable, laser weapons systems – unbelievable stuff – all over the country – Germany and the occupied areas.

They had massive underground production facilities that they were using – they had developed – for regular arms waste, like tanks and places to build Navy ships and all this kind of stuff.

Most of it was underground. So they started expanding those facilities, and they put 11 of these UFO-shaped vehicles in production.

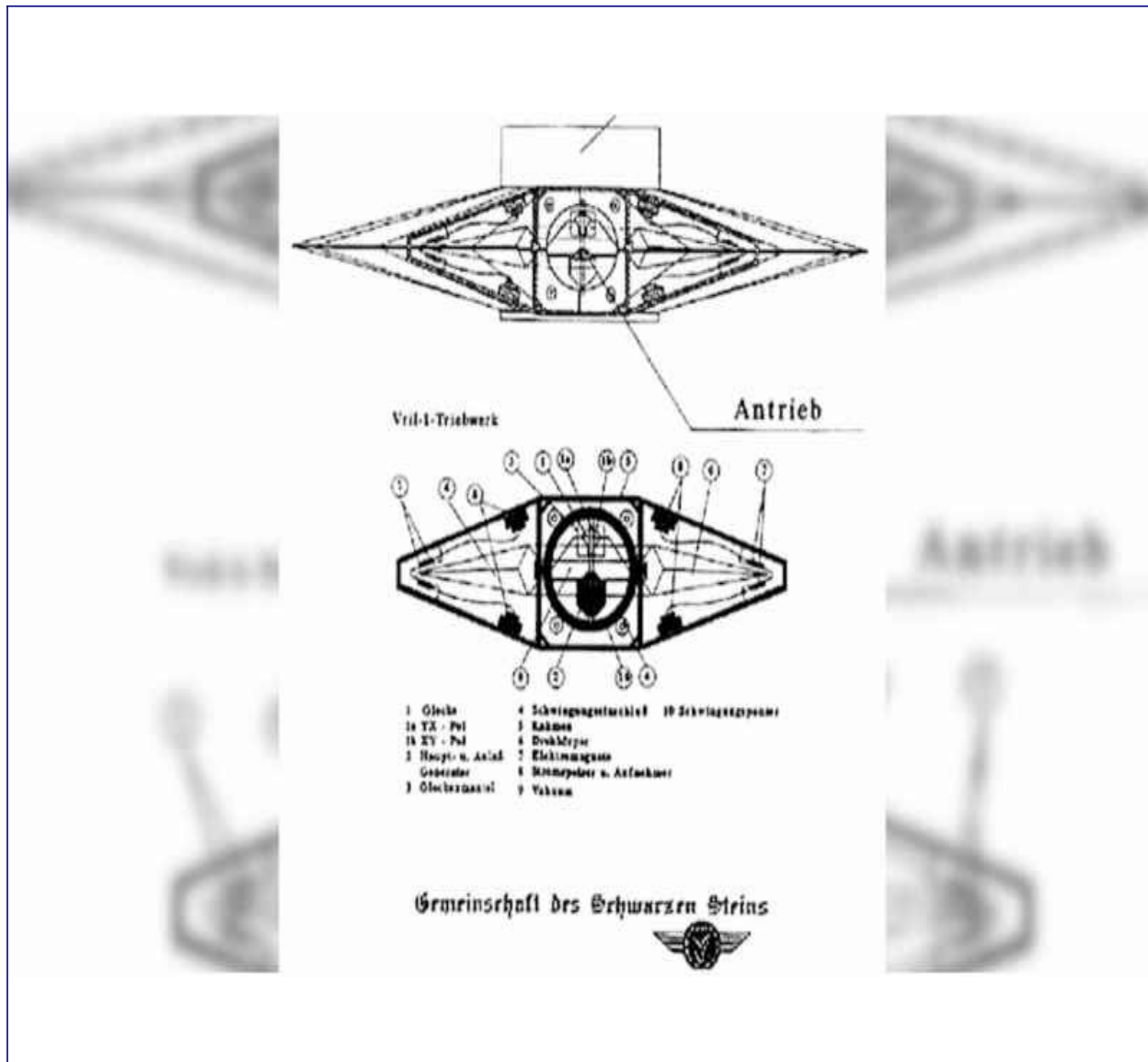

So the operatives are trying to explain to us, and the admiral would back off and say, “Slow down. I don't believe you.” And that went on, and then the captains would say the same thing.

The operatives were nice guys, and they knew they were going to get the questions when they got back into the admiral's office, and they knew that nobody was going to believe what they said.

So fortunately, the admiral had a typist in there, and the admiral's aide was NOT in there – he wasn't even cleared to be in there.

And one or two of the captains, the admiral, and myself. And we were the ones – the only people that this information was given to by the operatives.

I want to step back to my job in the Navy there working for Admiral Rico Botta.

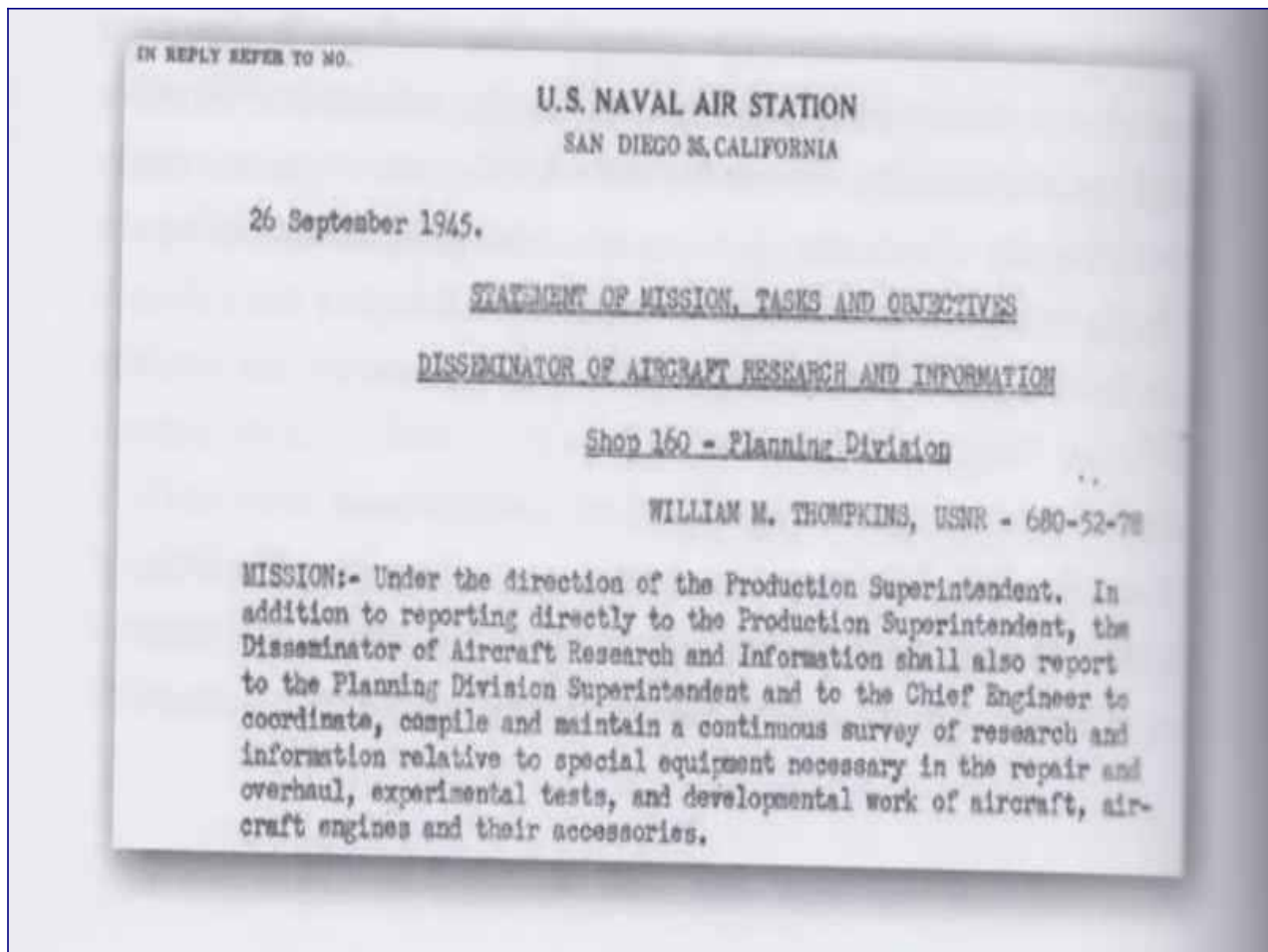

We talked about my mission – not my job, my mission. It's documented, okay? It's written by the Secretary of Navy Forrestal, who became the number one guy in the military.



Then he, like several other people, including our president at that time, were talking to a lot of other people.

And so he was supposed to have had a mental breakdown, so they took him to the hospital there in Washington at the top floor and pushed him out the window.

And so that's the guy that wrote Admiral Rico Botta's mission, which my mission came from his.

That was the level of this information in the United States.

Now, no other country but Germany knew about the extraterrestrials. Nobody did.

Now, as this starts to unveil the reality of what Germany was doing, it was like, the war is going to be over, period. They're going to take the whole planet, and they could do it in five minutes.

They even had trained a group of soldiers – an entire battalion of them – who were cloned.

They had cloned a whole battle group of soldiers.

They sent them out front, and they were killing the Russians unbelievably.

So it's not just the material, but the – and advanced medical systems, longer lives.



The size and the magnitude of what was taking place was unbelievable to everybody that got involved in the program.

The SS found out that people could live longer, so there was another big massive program in pieces brought back by the Navy operatives [and] plopped it on the table in front of Admiral Rico Botta.

And, of course, that ended up with about 24 packages because of the different magnitudes of living longer.

And I guess if you asked the question for the Nordics, their comparable lifespans are 1,400 to 2,200 years.

But they look exactly like us.



There is a study that we did later on at TRW on advanced life systems – extended life.

And that program is down now to, within less than two years, it's going to be available to some people on this planet.

The way it works – I'm very involved with it – essentially you take four aspirin over six months, pop them.

Or you get four shots.

You immediately change – everything is nicer. Everything is nicer. Okay?

What you do is you revert back to – the girl is 21 and the guy is 29.

Now, it takes a while for you to do this. You then stay at that time for essentially a couple of thousand years.

Your brain then . . . which collectively we're only using 2.2% of our brain. I don't care what they're telling us. We're only using 2.2%.

You get a minimum of 400% capability over what you normally had.

Now, what this does is this allows you to contribute. It allows you to contribute.

You go to work for the company here, 20 years they give you the watch, and you've got a couple three years later on, and you're out of the picture. Okay?

So you didn't contribute very long, all right?

Now, you're living two thousand years, and you can contribute and you also can have fun for 2,000 years.

And you don't change age. You stay there. Five of the top medical research groups – just like Scripps right here in San Diego – are involved in this.

And there's hundreds of companies involved in this.

There's a whole lot out there that is being removed from our part of our life. And we are in this position where everything that we've been taught – whether it's in the university or in medical or in any technical field, even mathematics – is baloney.

Yet, because we have allowed reptilians to put the stuff in our minds, it removes our capability to operate, learn. Our entire history – all the way back thousands of years - has been being controlled. We now know this.

This is not something that we think could happen. We now KNOW this.

So if you look at countries – you looked at the Roman times and you see . . . If you take in parallel these events back with that, the Romans were being mind-controlled.

They had the elite group, and they had all of the army, and then they had the slaves.

And that's where we are now. We're just finding out about this and we need to fix it.

* * * * *

David: All right. Well, as you just saw, that's a very dense amount of information that we've just gotten. It's unbelievable.

If you've been paying close attention to the show before, you've seen other episodes, then you're already aware of how much validation we've been getting there.

So here to discuss more about these details with me is **Corey Goode**. **Corey**, welcome to the show.

Corey Goode: Thank you.

David: So, first of all, we have **Tompkins** starting out, working from 1942 to 1946, actually debriefing these 29 spies that were embedded in Nazi Germany a total of 1,200 times. And he said that they had experienced this German Secret Space Program firsthand, and that the Germans had cut a deal with reptilians.

So just to start with that, how did you feel when someone comes forward and validates such a key part of your testimony on this show?

Corey: Well, I have to say it's gratifying, especially after knowing that he – I was told – has no idea who I am, couldn't pick me out of a crowd. So you know, this is leading me to believe that his program is what fed the data into - or some of the data - into these smart glass pads.

David: Right.

Corey: So I was most likely reading the results of his briefings.

David: Now, when we are talking about somebody like Secretary James Forrestal being pushed out the top floor of a building in the course of setting up this work, is that a common thing? Is there a short life expectancy for people that get into these programs?

Corey: Well, yes, and a lot of it depends on whether you toe the line or not. If you don't toe the line, then things – I mean, they're not afraid to take out a president, let alone a former – was he head of the Navy?

David: Yeah, he was Secretary of Defense.

Corey: Oh, Secretary of Defense?

David: Yeah.

Corey: Wow! So, I mean, since to them this secret is higher than the nuclear bomb, any other secret, then they think any of this type of retaliation on people that open their mouths or don't toe the line is justified.

David: Now, he said that Admiral Rico Botta's aide wasn't even cleared to have access to this information. That might strike some people a little strangely. Do you think that there are other precedents for that, in your own experience?

Corey: I saw that kind of thing happen all the time. You'd be in a briefing and they'd give a pre-briefing, and then they would have 5, 10 people have to get up and leave the room . . .

David: Really?

Corey: . . . because they were not cleared for the rest of the information.

David: Wow!

Corey: So I've seen that kind of thing happen a lot of times.

David: He also said that Admiral Rico Botta was constantly calling BS about the testimony that he was hearing, that it was just so fantastic-sounding, so hard to believe. And he said that the Germans were the only people, the only country at the time, that really knew about extraterrestrials back then.

So did you find that this wow factor was a fairly consistent element, that people just have a really hard time processing this when they first encounter this information?

Corey: Oh, yeah, absolutely. I mean, case in point, when I came out talking about being regressed 20 years, serving in a 20-year space program, I felt the same way. People were just . . . This is just too incredible to entertain.

David: Now, he also discusses in this short clip that we just saw, Nordics. And if you read his book, he's describing intensive encounters that he has later with Nordics, and we're going to have some interview footage on that later on.

But was it interesting to you, as well, to hear him mention that aspect of things?

Corey: Yes, because the Germans were in contact and working hard alongside the reptilians, as he stated. But there were Nordic groups involved as well, that different elements of the German Space Program were in contact with.

David: Right. Now, he mentioned that the Germans with the help of . . . He just calls them the reptilians. He didn't say 'Draco', So we'll just use that term. The Germans with the reptilians were creating a space Navy, and that their goal was to not just worry about conquering the Earth, but to use the material and the personnel of Nazi Germany to create an interplanetary, interstellar conquering army.

What was your feeling when you heard that?

Corey: I was a little bit shocked, knowing that he doesn't know anything about my testimony And I've reported the genesis of what we are calling the Dark Fleet for a while, and this is exactly the genesis.

They are working mainly outside of the solar system, working alongside the reptilians for defending territory and conquering new territory. That was their mandate.

David: It seems hard for me, just personally, to understand why people on Earth would give a darn about conquering other worlds if they only found out those other worlds existed a few years ago.

Do you think this is more of just something the Draco talked them into, as part of the deal?

Corey: That was a part of the deal.

David: . . . to get to the technology?

Corey: That was a part of the deal.

David: Because why would the Germans care about other planets? They don't know anything about this. They'd have no background in it.

Corey: Well, I mean, if you were 1930, '40 era, had that consciousness and perception of the world and you were told that all of this stuff was out there, that might change. You might become VERY eager to get out there and see it.

And if you are from a conquering kind of mentality force, hey, all the more better for the reptilians and their goals.

David: So he also said that the Nordics would live between 1,400 years to 2,200 years long. Now, that's over 10 times, maybe even 20 times, a normal human lifespan. Some people are going to have some trouble with that.

Have you seen any information that corroborates that detail?

Corey: Yeah, we're talking like, two or three times the age of Methuselah. Ha.

David: Right.

Corey: So, yeah, that . . . I mean that is actually pretty common out there in the cosmos. Once they've gotten to a certain technological place of development, they . . . the human body is extremely easy to manipulate, heal and all kinds of stuff medically.

So the bodies of these non-terrestrials, I would assume is similar. And if they can travel across space, they've definitely looked inward and figured out their own genome and how to manipulate it.

David: Now, another thing that might be contentious for some people that they're going to have trouble believing is his testimony that the Germans were actually cloning soldiers, and that clones were being used in combat during World War II.

What's your response to that aspect of this?

Corey: Well, I hadn't . . . That's new to me – that part.

David: Okay.

Corey: But I do know that there was cloning going on later on, that I read about, that the Germans were doing and that the Americans started doing as well in underground bases in these so-called NBC or biological weapons facilities. They were working on and doing a lot of cloning.

David: And speaking of these underground facilities, he said that the Germans were building these discs in several of them, and he also said there were several different prototypes that would go up to 500 feet wide.

Corey: Yeah.

David: Is that consistent with what you've heard?

Corey: Our shipping yards, or whatever, for when we were building our earlier craft? It was done in the same manner – in underground . . . that I was briefed about. They were in huge underground caves, and they were building them in sections, and putting them together and then flying them out into space.

David: Is the craft being as wide as 500 feet consistent with what you have heard?

Corey: Much wider.

David: Okay. And what about the chromoly steel that he mentioned?

Corey: That, I had heard. The ships were incredibly dense and heavy because they were using that era of material science. But they started developing material science, and within 20 years or so they were

having craft very similar to non-terrestrial craft that we would run across, to where you could pick it up with one hand and rock it.

David: Wow!

Corey: But I don't think it was quite there, but they developed quite a bit in their material science to make them lighter. But the weight really doesn't matter when you have the torsion or gravity-canceling technology.

It could weigh 1,000 tons and once they turn it on, it doesn't matter.

David: Sure. Now, he also said something that again, people may have trouble with, especially the more skeptically-inclined, and that would be . . . He said that within two years, we could have a life extension system released to certain individuals, in which you take four pills or four shots over the course of six months.

And he's saying some pretty outrageous stuff. He's saying that you're going to get a 400% IQ boost, that your age reverts to about 29, and that you then stay that way for like 2,000 years, and everything becomes better, and you feel better. Your life just is enhanced.

Does a technology like that exist that you're aware of?

Corey: Yes, and as I have stated in the past, some of the technology in some form was used on me at the end of the 20 years, when they age regressed me all the way back to the 16, 17-year-old range.

David: But you're not staying at 15, 17 years old?

Corey: No.

David: And you're not living for 2,000 years, obviously.

Corey: Right. But this is more of a maintenance kind of . . . If I was getting these chemicals on a semi-regular basis, most likely that would occur.

And that's one of the things about these programs. They want to make people reliant on who's running the program, to come back for more shots, pills, whatever.

David: Well, and I'll tell you, **Corey**, one of the things about this that concerns me, and I want to put this on camera, because I think it's very important, is that the space program insider, Jacob, he described to me that they – the Cabal – are going to try to get humanity to accept shots that will extend lifespan.

But he told me that there were going to be nanites in it, and that we would actually become merged with AI. So do you think that could be how this works?

Corey: That's most likely a type of scenario . . . You know, these are not real good-hearted people that are going to . . . If they've kept this technology hidden for 80 years or whatever, why are they all of a sudden going to become all benevolent and give out life extension?

There's always a catch with these people, so there's probably some sort of Trojan horse in the shots, just like most of the shots that people get now.

David: Do you know of a way that this could work that doesn't involve AI and nanites?

Corey: Well, I mean yeah, it obviously worked for me without nanites.

David: Okay.

Corey: I think to get me so quickly down to the age that they needed, they did a little bit different method. I wasn't taking pills. They did it intravenously.

David: Right.

Corey: But I only witnessed a pharmaceutical application to what happened at the end of my service. I passed out and all that afterwards.

The fact that he's talking about telomere manipulation and that type of a pharmaceutical innovation to help people extend their life, that's pretty good details that I hadn't had before.

David: Let me ask you this. Is there a way that if this technology does come out, that we could test it for nanites? Or could we shock it somehow with electricity or something so that if there were nanites in it that they wouldn't be able to work?

Corey: Yeah. Both of those are true. They could test them for nanites or just to not have to worry about it. They could take all of the samples through and hit it with an electrical charge.

That's unless introducing electricity is going to change something in the chemical.

David: Right. So we don't necessarily have to have a xenophobic attitude about this. If there is a technology that's benevolent, that comes out from the good guys, we can potentially use it, but we just have to have certain safeguards and caveats in place.

Corey: Right, and unless mortality was staring me in the face, I would probably sit back and let a few other people try it first.

MARIA ORSIC AND UFOs



David: All right, so now what we're going to do is we're going to show you another clip that gets into some of the more interesting aspects of Maria Orsic and the whole Nordic aspect of what **Tompkins'** testimony has to offer us. So check that out.

William Tompkins: So we had a young girl, Nordic, just outside of Germany.

Some people talked to her, and they said, you are now involved in a new program. And you're going to have great support in this program.

She had developed with . . . I think she had eight girls.



They were continually talked to telepathically to go and design spaceships.

<p><i>[Faint, illegible handwritten text]</i></p>	<p><i>[Faint, illegible handwritten text]</i></p>
<p><i>Handwritten text in the middle row, left column. Includes words like "Handwritten" and "text".</i></p>	<p><i>Handwritten text in the middle row, right column. Includes words like "Handwritten" and "text".</i></p>
<p><i>[Faint, illegible handwritten text]</i></p>	<p><i>[Faint, illegible handwritten text]</i></p>



 Die Reichsvereinigung
 der Juden in Deutschland
 Reichsvereinigung

Willkommen-Gedrucktes

Weiß-Gelände, den 11. März 1945

Liebe Willkämmer!

Es ist jetzt beabsichtigt, daß der OBIA-Ausflug zwischen Mitte und Ende April von hier aus stattfindet.

Alle jungen Willkämmer nehmen daran teil, von den älteren die die besondere Aufgabe haben. Das heißt also, fast alle können mit, es bleiben nur Maria Beck und zwei, die sie braucht. Außerdem soll eine ganz junge Willkämmer unter 20 sich freiwillig melden. Bei Maria zu bleiben, das ist wichtig. Maria mußte mit ihrer Gruppe gleich nachher einen anderen, südlichen Ausflugsort, niemand bleibt hier.

Mit frischen Mut
 zu neuen Taten!

[Handwritten signature]

Gruß

The little blonde actually built them. And eventually, two of those got over here in Area 51.

But Germany found out about the blonde, took her over, stopped everything, and then got to this point where there was some sort of pressurized program by the SS to control that original group.

Now, several times they did work together, but Hitler allowed them to operate independently of the whole SS program – the whole development.

So we had two developments going on in Germany. The girls didn't want their vehicles to be used for anything else but travel.

They were afraid that somebody would get a hold of it and they'd use it for military, which is, of course, what they got.



But the girls finally ended up in Antarctica, in the large facilities.

In fact, the reptilians had three massive caverns.

They let Germany use two small ones, but when you're talking about small, it's like as big as California.



So there's cities in both the extraterrestrial caverns, and manufacturing everything that you would need on a planet.

So then Hitler's group did the same thing.

Four years before the war was over, it was decided that the war could possibly be lost, but if we win it, we still need to get out of the area because the Allies are going to bomb us off of the Earth, and there won't be anything here left for us.

So they decided to move everything to Antarctica.

Admiral Byrd . . . They were going down there and they were going to take out the whole thing in one week. The top people in every area of the Navy – best aircraft, best ships, best weapons, everything.



And five weeks later, things didn't look very good.

When we got down there, they had decided they were going to have one thrust from the west side of Antarctica, and then the opposite side coming into both of them towards the center of the continent.

And so before we even got all the guys around and I'm talking about big four-engine flying boats, okay, and ships, battleships and destroyers and submarines and you name it.

Before they got there, these fairly large – they were 100-foot diameter saucers – came up out of the ocean and took down everything.

Now, there's a misnomer on some documentations about the photographs of some of the German UFOs. Many of the close-ups give you a real clear picture of the cross on them.



What was partially incorrect in that information that's been released was that not all of the vehicles came up out from the German side to take out ours.

But from the large caverns adjacent to them, unmarked UFOs and unmarked cigars came up, which then it was a joint venture by the extraterrestrials that lived there, operated from there, and built the vehicles that went to the Moon and Mars and all these other places.



But we lost that war.

* * * * *

David: Now, when he talks about Maria Orsic, we're dealing with what he said to be Nordics. Is your understanding that Maria Orsic was in fact a Nordic here on Earth and not a human born on Earth?

Corey: No. My understanding was that she made contact with several groups, one of them being Nordics.

David: Okay.

Corey: And she was the conduit for the Nordic people, that they were in contact with.

David: So she may have looked like them, but she was born here.

Corey: Yeah, every one of the people in her group, they were very beautiful. People would turn their heads if they walked by, you know, real long hair.

David: Now, we've heard from other sources that Maria Orsic was actually starting out this work doing automatic writing, and that she was, in fact, writing Sumerian language. And there were only three people on Earth who could correctly read it, and the Germans brought them in and validated that, in fact, that was accurate Sumerian writing.

Corey: And the same sources that she got the automatic writing communication from guided her in doing sketches and to look for certain ancient documents that would help them . . . give them a boost in their development.

David: Now, I thought there was something interesting in there as well, which was that Maria's team only wanted these vehicles to be used for transportation. They were not wanting it to become a military application.

That would suggest that whoever was helping her probably was not the Draco, but might have been some kind of benevolent group like these so-called Nordics.

Corey: Right.

David: So what are your feelings on that?

Corey: Well, that's usually what happens. If a negative non-terrestrial or entity makes contact with leaders of a certain group, then very often, either through like they did with Maria Orsic, or directly face-to-face, the benevolent groups come in and warn them and try to give them pretty much a hippie love and peace message. You know, get rid of all your nukes, and we'll give you all this technology – extended life, travel throughout the cosmos, everything.

And the military minds just couldn't accept that.

David: And I know that in **William's** book, he describes that there were a series of people beginning in the late 1800s that were all getting telepathically contacted independently and were all getting this initiative for a space program.

So do you think that these benevolent beings knew that the Space Program would be co-opted by the negative, but also, were they wise enough to see that we needed to have this for the time that we're in

now, so that we could also ultimately use those tools to defeat the Draco and help kick-start us into this Ascension/Golden Age?

Corey: From what I've read, it seemed like they were bringing balance to a situation. We were getting all of these advanced weapons of war, and we were interacting with a negative force that wanted to go out and take over other planetary systems.

So them coming in, providing technology and more of a benevolent message on how to use the technology, was their way of trying to counteract it, because the technology was not that incredibly different than what the Germans were getting from the reptilians.

David: How does it feel for you as a whistleblower who's been out there risking your life . . . You've had all kinds of problems, all kinds of hardship and setbacks, and people have said that you're a charlatan, a liar, a fake, etc.

How does it feel to see **William Tompkins** validate Operation Highjump?

Corey: It's gratifying, but a little shocking, too, because, I mean, I'm really beginning to believe that a lot of his briefings during the time period – '42 – were what made it into the database that I was reading on the smart glass pad, you know, like 30 years ago.

David: Right, because as he said, there was a stenographer that was there typing up everything that these 29 different embedded spies said over the course of 1,200 briefings. And that was just the ones that **Tompkins** personally supervised.

Corey: Yes, and we were viewing old typeset documents.

David: Oh, really?

Corey: Yeah.

David: I didn't know that. Okay.

Corey: Yeah.

David: So you would actually see the original typewritten paper documents?

Corey: Yeah. Yeah. Well, there were redactions, but very little redacted.

David: Wow! So when he said that there were unmarked craft as well as German craft, and this included cigar-shaped craft . . .

Corey: That was new to me. I had not heard that.

David: Okay.

Corey: But I wouldn't doubt it, because if they're allied with the reptilians, and we come down to an area that's mostly reptilian-controlled, of course, they're going to come out and back up their new ally.

David: Now, another thing that I find absolutely shocking - and I would hope that you watching this at home will dig this as well - is how he said that two main areas were like leftovers and were given to the Americans [Transcriber's note: I think **David** means 'given to Germans' not 'Americans'] underneath the ice in Antarctica, in addition to these much larger Draco areas - that there were three, very large Draco areas.

Now, you've independently - before this ever happened, before you knew about **Tompkins** or I knew about **Tompkins** - had said that there were two major areas underneath Antarctic ice, and then some smaller ones as well.

Corey: Uh-hmm.

David: So what does it feel like, again, to be seeing so much precision in the line-up of these testimonies?

Corey: It makes me hungry for more.

David: Yeah.

Corey: You know, I'm ready for more from **Tompkins** and more from some of the whistleblowers that we hear are starting to come forward. So it was exciting, but we need to hear more. This is great.

David: So we're seeing independent, verified testimony of Operation Highjump. All the things that you said, showing up very paralleled, in which Byrd goes down there with this huge army.

We have these - it appears to be - Draco and Germans that are striking against them, and they are very, very heavily-damaged, and they have to limp back.

Corey: Yeah, they were crippled.

David: So this is really very tightly-aligned with what you saw in your own briefings.

Corey: Yes, and I guess I was reading what **Tompkins** and his group had reported.

David: I just think it's important for people to understand watching this at home that I can't bring out some people that I know, but I have other folks who are saying exactly the same stuff that you've said, that **Tompkins** has said, that others have said.

And it's when you get this many different sources that are all telling us the same thing, that you now have veracity. You have proof.

So the proof is not all the way as far as people want it to be, but we're getting closer and closer all the time.

Corey: Well, a lot of these skeptics, if one of these craft were to land in front of them, would still be in denial.

David: All right. Well, this has been really fascinating. I want to thank you for watching our show. This is certainly mindblowing.

After all this time, people say, "Oh, **Corey** has no validation." Well, what you've just seen here is a gamechanger, and I encourage you to tell everybody you know about this, because now that we're bringing this all together, maybe a lot of people who wouldn't have taken this seriously before are going to take a second look.

And we do need your help. We need as many people as possible to educate themselves about this.

As **Corey** just said, it's vital to humanity's future that we no longer act as ostriches, that we have the awareness of what's really going on.

This is "[Cosmic Disclosure](#)". I'm here with **Corey Goode** and **William Tompkins**. I'm your host, [David Wilcock](#), and I thank you for watching.

[Cosmic Disclosure: William Tompkins Bio](#)

Season 5, Episode 11

David Wilcock: I'm glad you're here for this one, because this is going to blow your mind. You're about to see a biographical sketch of **William Tompkins**, an aerospace engineer, who has come forward as an insider with exclusive knowledge in a wide variety of aspects, specific data points related to the Secret Space Program that we have been disclosing in the show that I have here with **Corey Goode**.

I want you to see this now and get into the details of all the amazing intricacies of **William Tompkins'** illustrious career. Check it out.

Narrated by **William Tompkins:**

I had, for whatever reason, been interested when I was a kid, nine years old, in building Navy ship models.





To get more information, I'd go to the library and I'd try to find what you could get on the library, and then there's be news broadcasts about different Navy ships sometimes.

My dad though took my brother and I, older – he's older than I am – down to Long Beach. We were living in Hollywood.

And he would take us down to Long Beach on the weekends, where in the early '30s there, the Navy was concerned about what the Japanese were doing in China.

They decided to move the Eastern Navy to the West Coast, but they didn't have a harbor.

So they had to wait for the construction of a breakwater right off of Long Beach.

And this breakwater then was large enough to actually handle both the Eastern Navy and the Pacific Fleet.

So this was all new to everybody when these ships came in. And to me it was wonderful, because I could go down to the bay and I could . . . You can't use cameras, but I could sketch all the radar and the classified stuff, because the ships are only 10 or 12 blocks off of Long Beach.





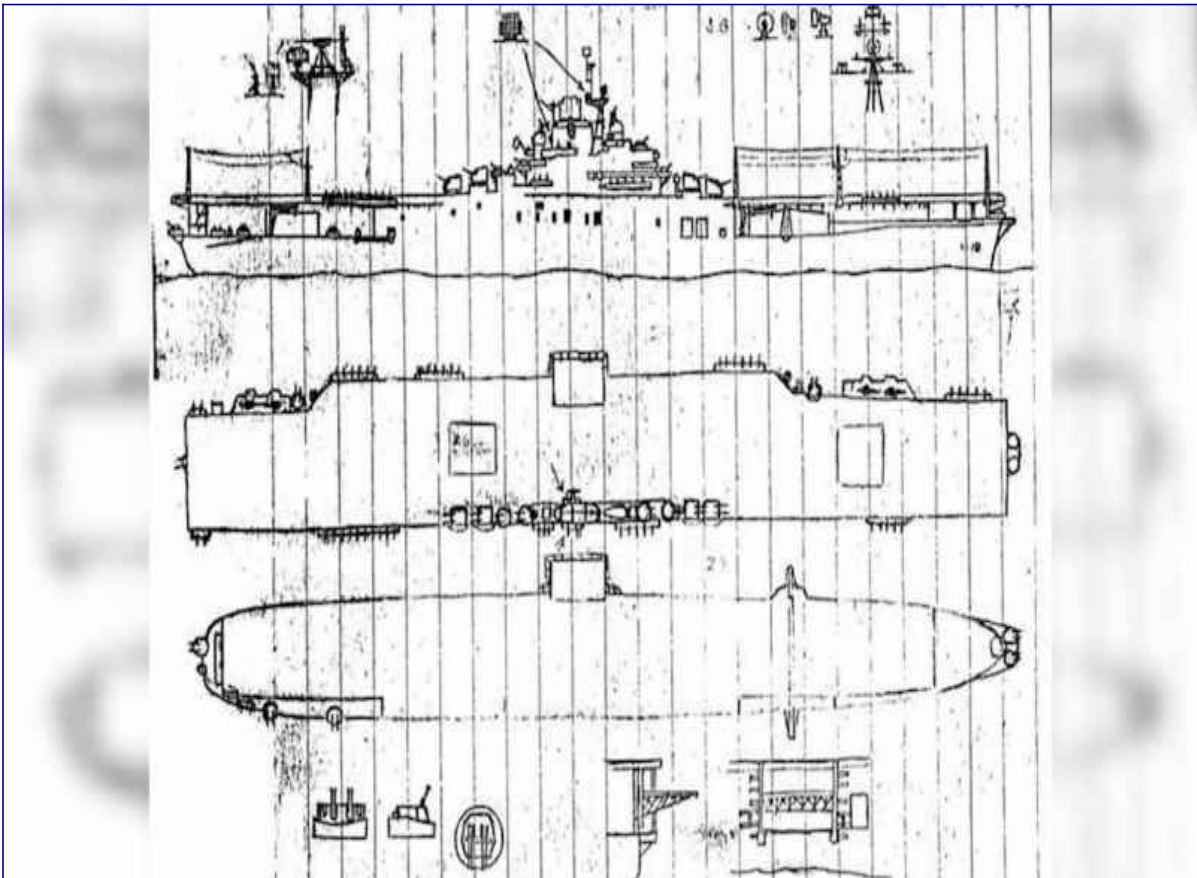





So then on weekends, the Navy allowed people to come on board and just walk around on the ships. So my dad took my brother and I down there.

And I was really interested in the aircraft carrier. We had two of them at that time, and the “Lexington” and the “Saratoga” were both right there.

That great big enormous aircraft carrier, 1,000 feet long – crazy – stood up like 11 stories high.

And when you get up inside, it's a big enormous hangar, and you wouldn't believe the size of it.

But the whole thing looked to me like it was a space vehicle that somebody had built. That's the way I saw it. So I needed help for building the “Lexington” aircraft carrier.

So I needed the radar. I needed a lot of other details of the five-inch guns, 20 millimeter, 40 millimeter, where all this stuff was, because, remember, at that time they were refitting every ship, almost, for battle conditions with the latest equipment that they could come up with.



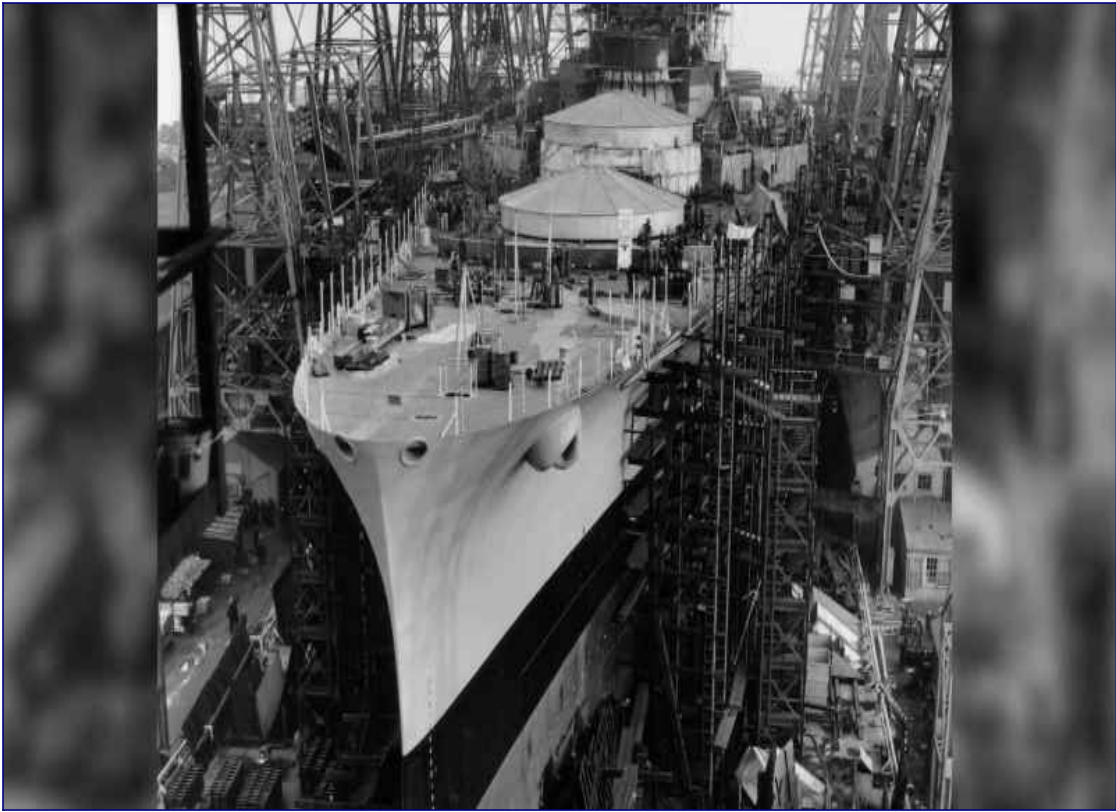

To get the radar, I would walk the flight deck and way up there on top of the tower next to the control center, there would be a shadow that would come down, and this shadow then gave me the opportunity to walk two ways of it, another two ways, and mark it down.

And I could figure basically the shape and the size. And I was really good on being able mathematically to come up with what it was.

So then I would walk up to the bow of the aircraft carrier, and they had these secret steam catapults to catapult the aircraft off so they could get them in the air faster.



Of course, it was classified, but I just walked around, and I got all my numbers and came back. And on the way home, while dad's driving us back to Hollywood, I would start making my perspective sketches.

Later on in the week, after school, I would make a detailed drawing. And then I would build that part of the ship and put it onto the model.

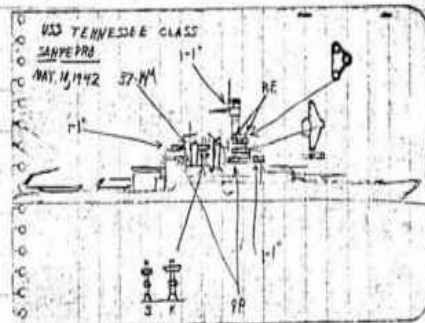
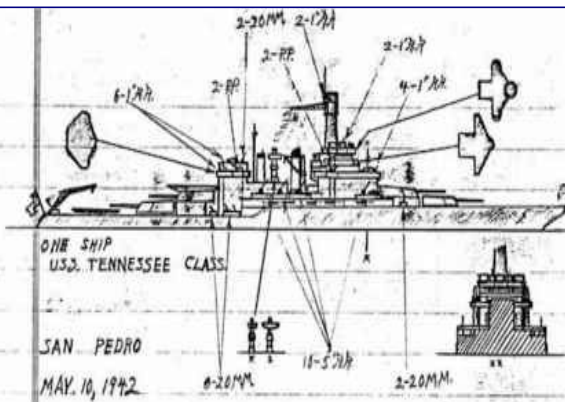
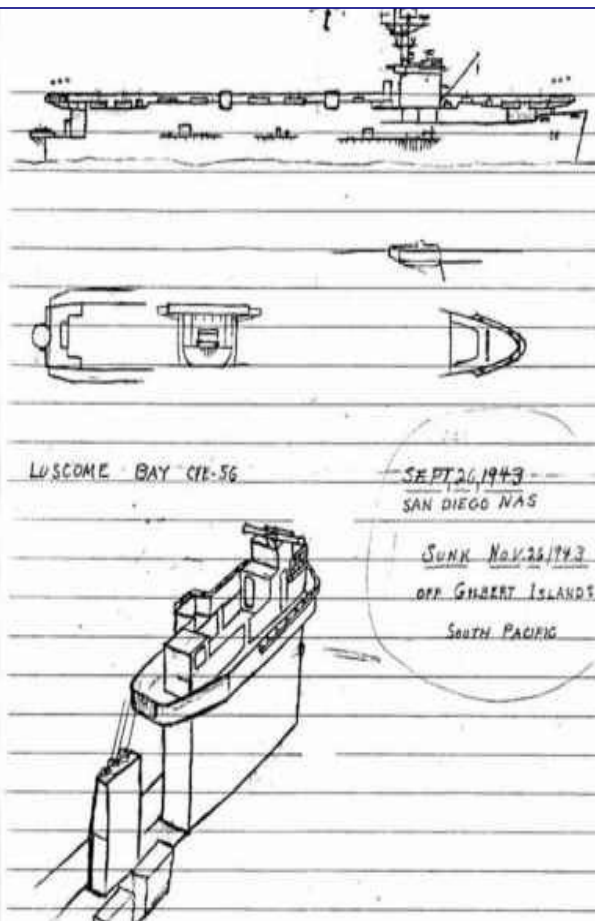





Douglas Engineer Adds Airplanes to Hobby

So realistic is the hobby of William F. Tompkins, 28, that naval authorities prior to World War II cautioned him for possession of restricted Navy craft blueprints.

Tompkins, now a Douglas Aircraft engineer, did not have Navy blueprints, investigators learned, but did possess an unusual accuracy for detail with which he has built a fleet of 31 Navy warships.

TINY SHIPS

The miniature fleet ranges in size from an 18 1/2-inch replica of the carrier Lexington to motor launches 1 1/4 inches in length.

Principal material used in construction of the intricate models, Tompkins yesterday explained at his home, 2324 1/2 11th street, Santa Monica, is balsa wood carved with a razor blade.

Sheet aluminum, pins, wires and needles are used for such things as gun emplacements, lifeboats and airplane wings.

Tompkins began his shipbuilding hobby at 14, and today can build the less complicated ships in six weeks. The Lexington model took six months.

NAVY PILOT

A Navy pilot during World War II and a graduate of Hollywood High School, Tompkins has been using his model building skill to produce wooden reproductions of future airplanes. Recently he was transferred to



THE FLEET ARRIVES—William F. Tompkins, 28, Navy pilot during World War II and now an aircraft engineer at Douglas plant, displays part of his fleet of 31 warships. He also models airplanes as part of his hobby. Navy ships vary from 1 1/4 to 1 1/2 in. in length.

the engineering department at Douglas and is wavering a little in his original desire to become a naval architect.

San Bernardino Telephone Users Reach All-Time Peak

SAN BERNARDINO, Feb. 9.—To accommodate the growth of local telephone service by the San Bern...

GET N

San Bernardino Wholesale

SAN BERNARDINO

In the most extensive since its founder took over every five days a new job Miss

Master exp pose of the signed "to be supervision, t greater effie broader depa orientation of areas."

In most case are shifted, the transfer from a Valley substitutes changes within in the reaction W. Corbett, shifted from 1 store.

AT TOP LEFT

In top level Elder becomes detective in investigation; Lt. Jo is the new chie trative intelligen

Inspector H. i responsible for dupation, some case, the jail rescue operatio Capt. Lester J at the new d training with 1

So we got to be about 40 ship models in this collection, and so some people found out about it. Newspapers found out about it, and they had articles written about the Kid's Navy.

So the Broadway Department Store on Hollywood Boulevard requested that we show the models in their front window.

So they opened up a great big area.

They had a table inside for me with a desk, and I had some of my model stuff there, and they had me demonstrate how I would make the models.

And I did that after school all week long and the Saturdays and Sundays. So it was quite an effort.

But the first article that referred to this got several Navy people that were on leave to come up from the base into Hollywood. They were going there anyway, and so they went over to where the models were.

And they couldn't get over looking at the accuracy of these models. So one of them contacted a Naval Intelligence guy. And this then got to be sort of a hard story.

Naval Intelligence came from San Pedro to my dad's office on Wilshire Boulevard. They confiscated him. They investigated him for 2 ½ days and finally figured out that he was not a Russian or a spy or something.

But in that conversation, they then came out to our small apartment in Hollywood. I shared a bedroom with my brother, and actually I had stacks of paper that were piled up halfway around the height of the room.

These fellas came in this little room and looked at this stuff. They studied it. They came back three days later. They reviewed it. They came back four days later, and they reviewed almost everything that I had.

And I had hundreds of sketches, hundreds of drawings, hundreds of pre-perspective-type things, because I would get all these crazy things, and I was visualizing how all this would come together for the models. So they let my dad off the hook. Okay? From there, we had moved to Long Beach for my dad's business, and we were only 11 blocks from the beach.





So now I can go down to the beach, and I can get all the latest stuff. And that really worked.

I went to a special school down there for a couple of years, came back to Hollywood and got into junior high in Hollywood. And then, of course, the drafting class.

And this young girl that was sitting next to me, she couldn't get over how fast I could make the drawings.

I was way ahead of the class all the way through, because I'd been doing this stuff myself.



We graduated to Hollywood High School, and she was actually in my English class. And I was not an introvert, but I just was not . . . I didn't like English. I didn't like talking in front of people or anything like this.

But she was there, so she at break - we would talk and everything, and I would sort of calm down. Anyway, the teacher picked me out and wanted me to come up in front and talk to everybody.

So I talked about the ship models, and I talked about going on these aircraft carriers and destroyers and cruisers and submarines and all this stuff.

I learned how to speak in that class to where I was called, from information about the ship models in the newspapers, to speak at the open stadium in Hollywood, the Hollywood Stadium, and spoke to four different groups about the Navy.

And I spoke just like I'd been speaking as a speaker professionally. It's unbelievable what that class did for me.

One of the people that was involved with the Navy asked my dad to take my brother and I up to Mt. Wilson Telescope, which was just east of Pasadena, a beautiful area up there.



So looking through that 100-inch telescope was sort of an event.

And being able to listen to some of the meetings that were going on with the astronomers, they just allowed us to sort of participate in their daily workloads.

So it was surprising to me that some of the questions that were going back and forth indicated to me that there is nothing out there.

And I somehow, at that point, I knew that there were planets out there that had people on them. I knew it. There wasn't any question.

And so I sort of brought this up a couple of times and, of course, I get pushed away because these fellows have all got their eight years in astronomy, and they know what's going on, but they didn't.

And so that little part then led to the Navy Intelligence again confiscating my dad and I, and took us down to San Pedro, and put together a package for me to go in the Navy and implement some program. I didn't know what it was.

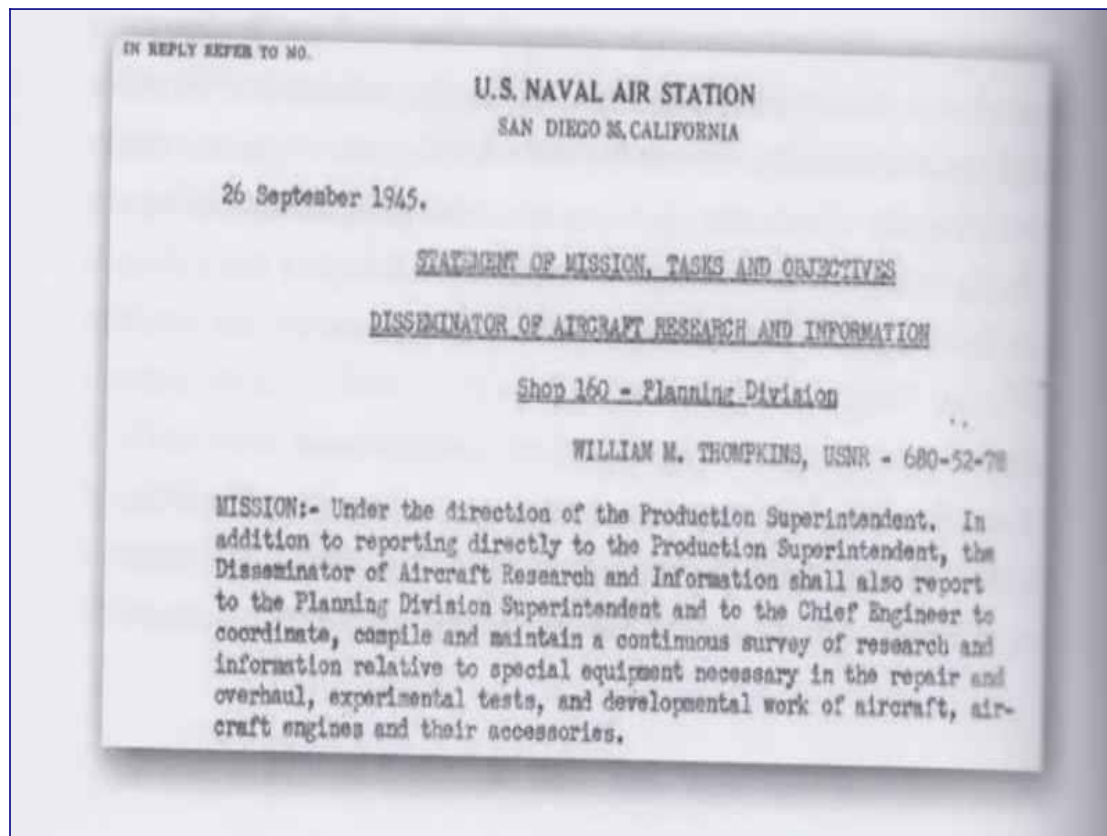

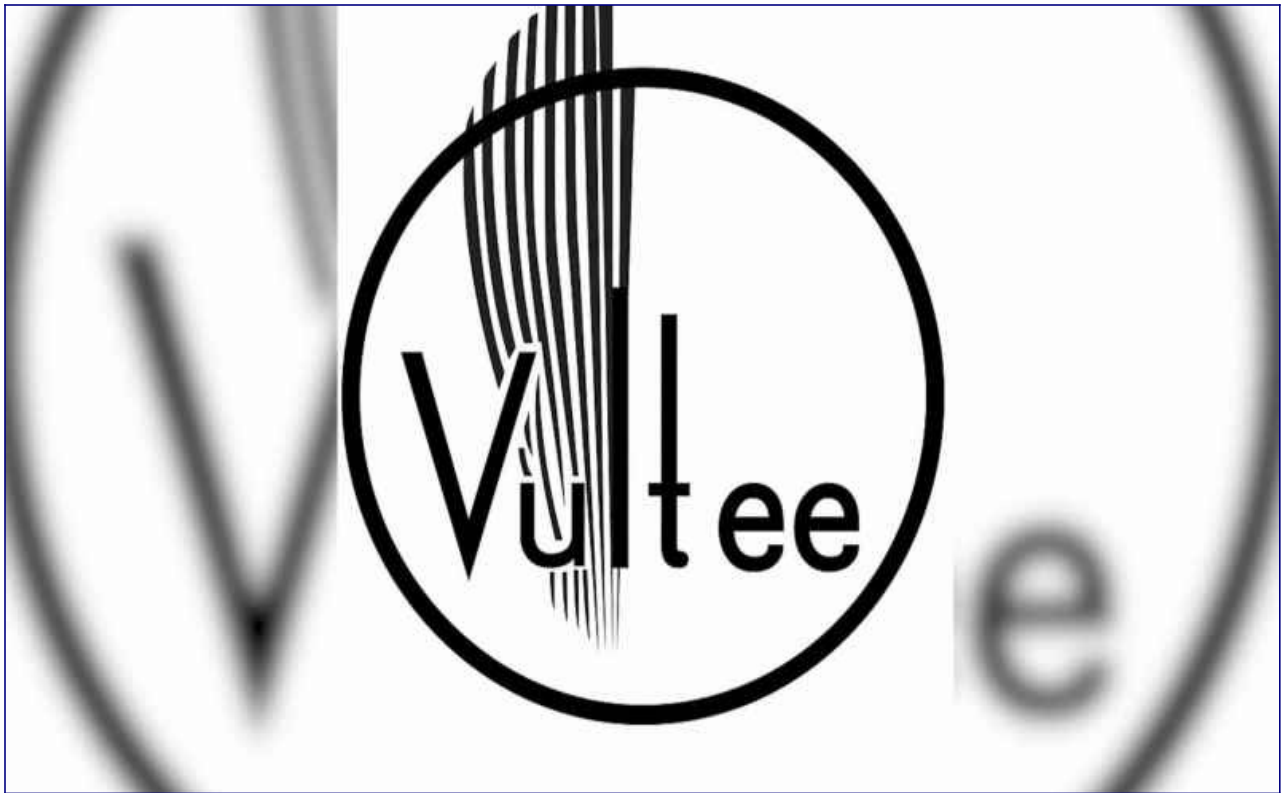

Instead of going into boot camp right away, the Navy sent me to Vultee Aircraft over in Downey, California, just right in the Los Angeles area, which is now North American Space Systems.

The job there at North American was converting extraterrestrial communications systems and then making them work and then copying them.

So then I went over to Lockheed, and I got in the wind tunnel over there.



And they pulled me out of the wind tunnel, and they put me in other research.

I had this feeling that, yeah, Lockheed is good, but there is something going on over at Santa Monica – Douglas. And I went over there and signed on as a draftsman.

And I got in the door with the ship models. In a very short time, Douglas company used my ship models, and they were taking them all over the place, advertising Douglas Aircraft Company.



So then the Corporate Vice President of Douglas nailed me and had me build a very large sailboat, which is to be a copy of Douglas Sr's sailboat that he had tied up down at San Pedro.

So I had to go down there and measure stuff and come up with the drawings. And I built the thing in a real short period of time because I knew how to do it. And they gave it to him for Christmas.

So now I'm in with the Vice President of Douglas.

So I went to work then at Douglas, and I'm a draftsman for two weeks, and my Section Chief started through my background.

And, of course, it says all of this stuff that I had done in the Navy. So he puts me in this think tank, and there is where we get to the first think tank, okay. [It] was inside of Douglas in a walled-off area.





NDM-622

UNCONVENTIONAL PROPULSION SCHEMES

PART 2

REV. 3-1-55

SANTA MONICA DIVISION

C/P/PHI:hg/vc

19 May 1945

To: All Bureaus, Boards and Offices of the Navy Department
The Commandant, U. S. Marine Corps
The Commandant, U. S. Coast Guard

Subj: Office of Research and Inventions.

1. There is hereby established, in the Office of the Secretary of the Navy, the Office of Research and Inventions at the head of which shall be a Chief and an Assistant Chief, appointed by the Secretary of the Navy and designated, respectively, the Chief and the Assistant Chief of Research and Inventions. In addition to reporting directly to the Secretary of the Navy, the Chief of Research and Inventions shall also report to the Chief of Naval Operations. The orders of the Chief of Research and Inventions shall be considered as emanating from the Secretary of the Navy and shall have full force and effect as such.

And there's 200 guys in it. And one of my assignments was like 12 years old, and it was one that I had carried to Douglas. I flew to Douglas and gave to the Douglas Engineering when I was in the Navy.

And here's in the files – I had to refer to it – and here's one of my documents that I did in the Navy, and I flew and gave it to them.

And so it turns out that this becomes the first think tank. Like TRW later, we investigate every aspect of extraterrestrial - military, commercial, whatever.

And I was assigned to design for the Navy about 16, 18 different classes of US Navy battle group ships, which didn't exist.



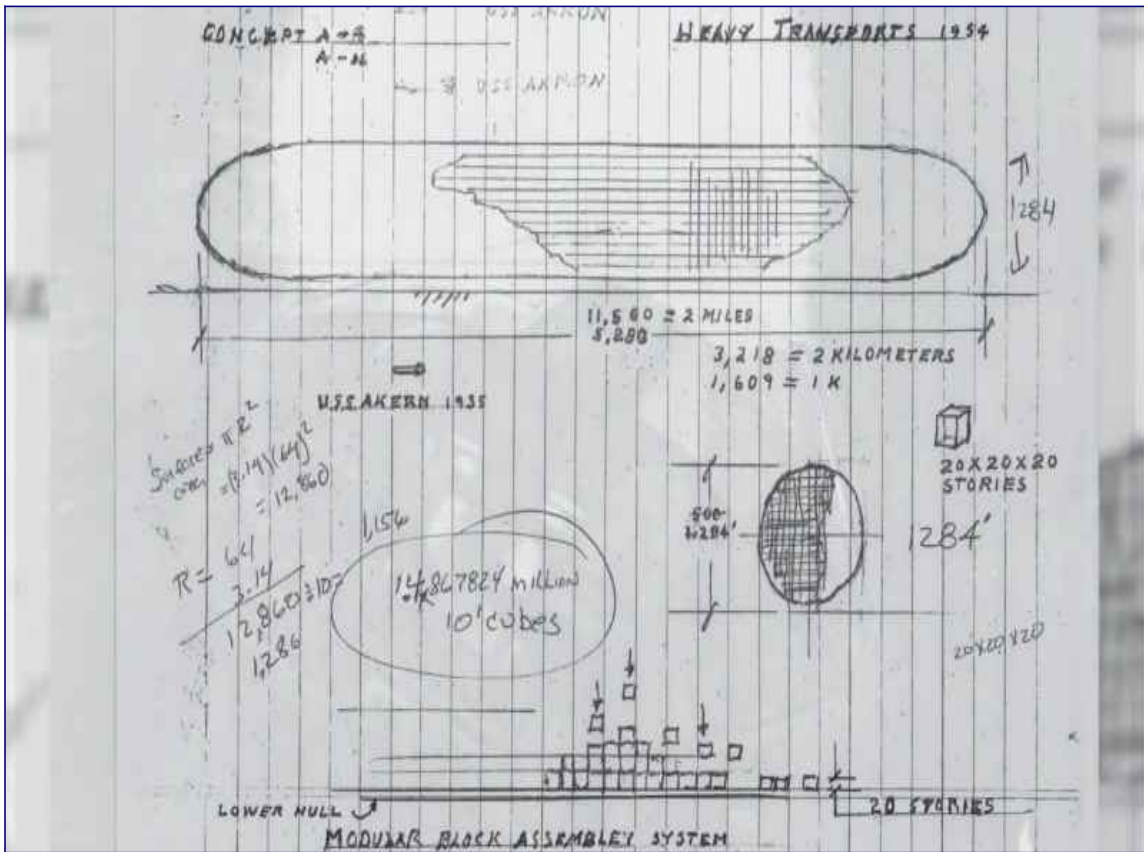
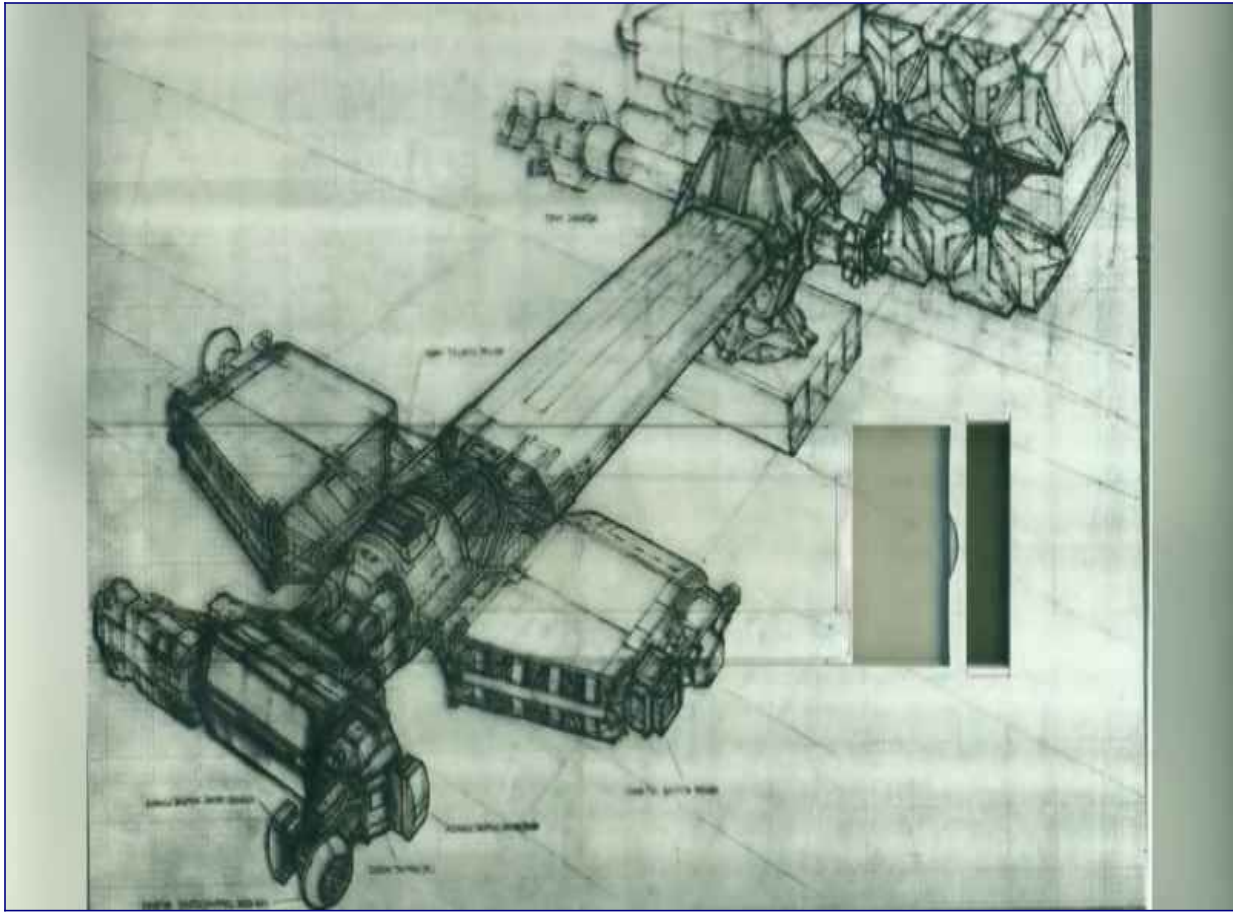

And the larger ones were from 1 kilometer to 6 kilometers.

These ships fly in space.

They're spacecraft carriers. I designed US Navy Spacecraft Carriers, which finally got built back in the late '70s up in Utah, underneath the ground.

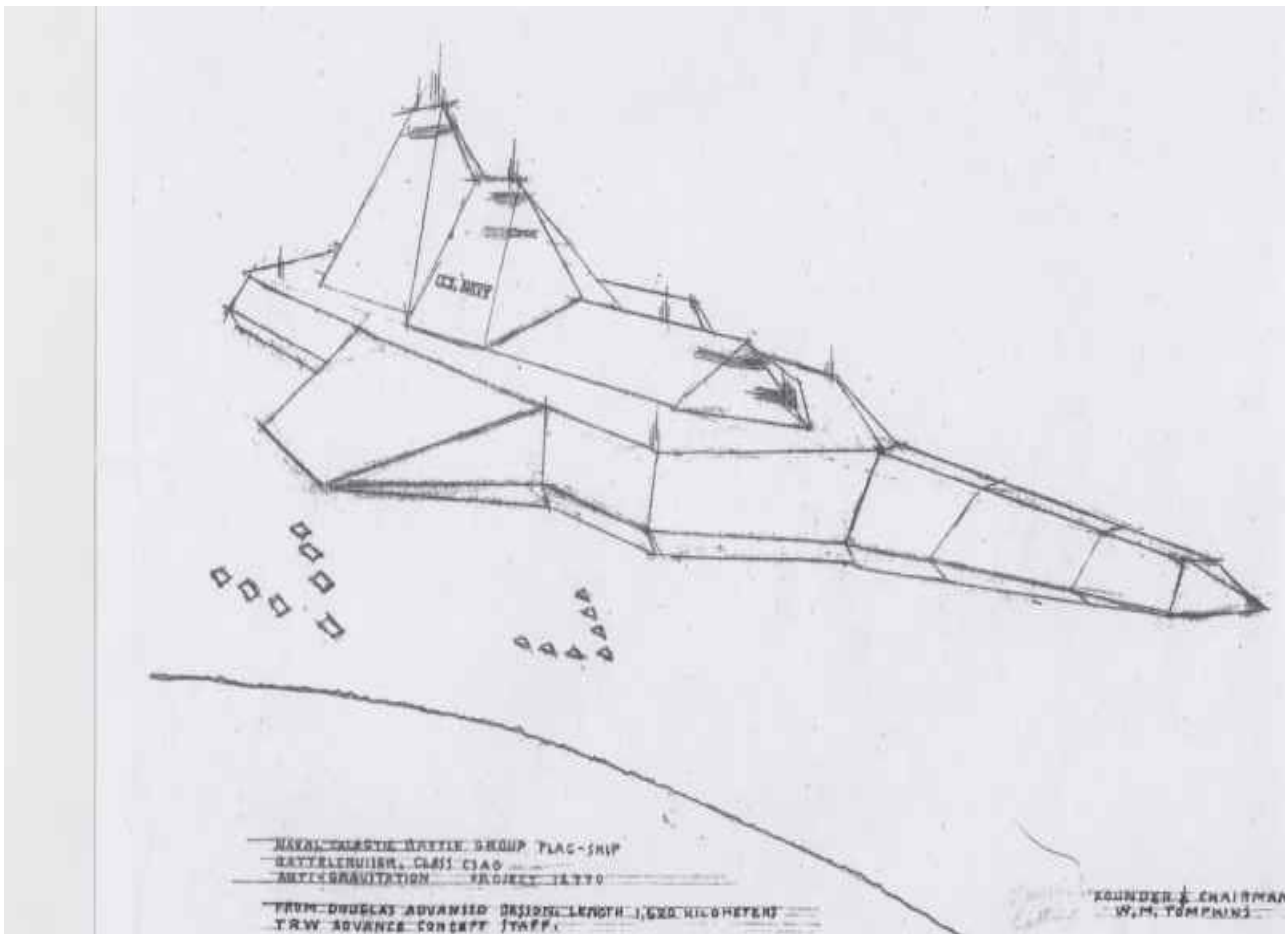

And you've seen the pictures of US Navy spaceships – Solar Warden. So Solar Warden came out of a think tank inside of Engineering at Douglas.

And a whole lot of other stuff came out.

Cosmic Disclosure: SSP Think Tank with William Tompkins

Season 5, Episode 12

David Wilcock: Hi, I'm **David Wilcock**, and you're watching "[Cosmic Disclosure](#)". I'm here with my co-host, **Corey Goode**. And as we saw in our first episode interview with former aerospace engineer **William Tompkins**, he is the consummate insider.

We learned how spies discovered what the Germans had really been working on, including the invention of actual working flying saucers.

In this episode, we're going to go even further into the life and times of **William Tompkins**. He's going to start out telling us about the secret think tank he was involved with while he was working with the Navy and dealing with the Secretary of Defense, James Forrestal.

MAJESTIC 12

William Tompkins: He's the Secretary of the Navy. He's sort of the top guy. And unlike many military organizations around the planet, everybody liked Forrestal. All the people did. He was really a beautiful guy. And he knew what he was talking about.



But his people were essentially like a short name, a name that was abbreviated.



And so it had quite a few different titles to it. That group were essentially the apex of the Alumni.

So at Douglas, we had the situation where putting together packages among different areas that we were working on in the think tank – now other people in the tank were aware of who Forrestal was.

And they were aware that we should not be using his group's name.

But essentially, every document that we came up with inside that secret think tank – how will this be accepted by that group? Are we deviating from their agenda? What is their agenda? Who are all of these people? Is the Bilderberg involved in this? Are other organizations – secret organizations – are they involved in this? We then structured our presentations to them when he came out to assume Forrestal was the number-one person in the country who ran the PROPER organization, the REAL organization, to handle technically the extraterrestrial.

SUBJECT: OPERATION MAJESTIC-12 PRELIMINARY BRIEFING FOR
PRESIDENT-ELECT EISENHOWER.

DOCUMENT PREPARED 18 NOVEMBER, 1952.

BRIEFING OFFICER: ADM. ROSCOE F. HILLENKOTTER (MJ-1)

NOTE: This document has been prepared as a preliminary briefing
only. It should be regarded as introductory to a full operations
briefing intended to follow.

* * * * *

OPERATION MAJESTIC-12 is a TOP SECRET Research and Development/
Intelligence operation responsible directly and only to the
President of the United States. Operations of the project are
carried out under control of the Majestic-12 (Majic-12) Group
which was established by special classified executive order of
President Truman on 24 September, 1947, upon recommendation by
Dr. Vannevar Bush and Secretary James Forrestal. (See Attachment
"A".) Members of the Majestic-12 Group were designated as follows:

Adm. Roscoe F. Hillenkoetter
Dr. Vannevar Bush
Secy. James V. Forrestal*
Gen. Nathan F. Twining
Gen. Hoyt S. Vandenberg
Dr. Dudley B. Rowland

We have now what essentially is the US Navy space systems, which is not an organization, but it's inside of the secret think tank at Douglas.

That operation was controlling everything in the country, and the President of the United States was not included. Top military people, congressmen were not included.

So here we are giving away the store to the people that are causing the problem. And I think this is hard for us to accept, but this is what was going on. We didn't know it, but that's what it appeared to be.

In documents that I put together and several of the others that were submitted back to the Navy, I would make comments on, essentially, "Who does this information go to?" This was a continuous problem in the secret think tank.

SECRETARY OF DEFENSE JAMES FORRESTAL COMMITS SUICIDE!

Secretary of Defense James Forrestal leaped from the 14th floor of the naval hospital in Bethesda, Md. Park Police suspect the 48-year-old Foster had died by suicide.

MAJESTIC SECURITY has been successful in part because of classified activities of the level system of the Manhattan Project, and new in-plant weapons development.

In protecting the security operations of [MAJESTIC], it has been necessary to [redacted] individuals who would compromise the intelligence efforts. While distasteful [redacted] at times, the use of [redacted] measures have been executed. The untimely death of [Secretary Forrestal] has deemed necessary and [redacted].

[Faded text, likely bleed-through from the reverse side of the page]

Dr. Klemperer – he's a real nice guy, smart, brilliant, and you can kid with him, okay? He's my boss.

Klemperer was convinced that there were two different groups. There was the standard organizations – the Navy's levels of information. And then you got this other group up on top.

And we know that the admiral was heading that group up on top. He was the head of it.

So we assumed after he was assassinated that that was then true, because he then was talking too much.

These are the complexities of the program where we're off by ourselves, not being influenced by anybody. We're coming up with what we think we're going to have to do to solve an unbelievable problem.

And when you don't know who your boss is, you do the best you can.

* * * * *

David: What you're seeing here is very corroborating information with what so many others have been telling us over time about this mystery of how do they keep this stuff secret.

People say, “Oh, the government can't keep a secret. They can't even find a file in a file cabinet. How could they keep these things secret?”

Well, **Corey**, when we're hearing about the guy who ultimately becomes the Secretary of Defense and was the first Secretary of Defense in America, Forrestal – and even he – they don't know who he's really working for. They don't know . . . Yeah, he's the head of the Navy. He becomes the Secretary of Defense, but he mentioned this thing he called the “Alumni”.

And when I hear that, I'm think “Illuminati”.

Corey Goode: That's a name that's been used for them before in the military.

David: You're saying “Alumni”?

Corey: Alumni.

David: They actually used that word?

Corey: Mm-hmm.

David: And that actually means “Illuminati”?

Corey: Right. That was their name for it.

David: He also kind of dances around a code name for this group, but he doesn't say what it is. It appears to be MJ-12. Would you agree with that? That's what he's talking about?

Corey: Yes. Yes.

David: Okay. Have you ever been in a situation where the people that you're working with don't know who they're reporting to or what their agenda really is?

Corey: That's the basic tool they use to keep people oblivious to what's going on. And everything is highly compartmentalized. Even on the vessel I was on, everything was compartmentalized.

David: Could you give me an example?

Corey: Well, there was a large area that was a bay that we would use for transportation, and everything was modular. So the bay would be this open. [**Corey's** hands are about three inches apart.] You'd push it all the way open and then start building out laboratories or whatever else needed to be in there.

And we would not . . . If I was working with a certain group of scientists, we would not have any idea what the other . . . just on the other side of the wall, going right next to each other.

David: In the same research vessel?

Corey: Right.

David: Really?

Corey: Yeah, and they do things like they'll give us a special access program – the same name as a regular military program that's secret, so that if one of the programs' names is thrown out there, they can say, “Oh, look, it's tied to this.” This is a secret program, but it's not what you think it is.

David: He was tossing out some alphanumeric codes that were like alternative titles for this group. Is that commonly done? Is that kind of what you're talking about now?

Corey: Yeah. Yeah. You give a group several different names so it causes confusion if people start to talk about them. They'll be like, "Who?" You know, "Well, I knew a group named this." And it just adds to the confusion.

David: This compartmentalization that we're speaking of, do some of the people in some of these space program factions not even know that there are other factions?

Corey: Absolutely. Hardly any of them know about other factions. They will often know a little bit about less technological factions below them. A lot of them have come up through those. But they are not privy . . . If they see another craft, they're told that it's a concept craft for their program, not to speak about it to anyone.

David: Right. **Tompkins** also described that this guy, who supposedly is answering to this shadowy MJ-12 group, ended up getting murdered.

Now, that suggests that there is something nefarious going on. We know the term MJ-12 didn't even come into the public lexicon until the 1980s thanks to **William** Moore, Stanton Friedman, who got this roll of 35mm film that had documents on it that up until then had never been available in the public domain.

Yet, **Tompkins** clearly seems to have known about MJ-12, even though he didn't want to say the name on camera.

Why do you think people are so afraid of these guys, and what do you think happened to Forrestal?

Corey: Well, Forrestal, it was reported in the smart glass pads, was one of the people that had been eliminated.

David: Oh, really?

Corey: Yes.

David: It said that in there?

Corey: Yes.

David: Really?

Corey: Yeah, and I don't know who the other people are. A lot of their names I would have no base of reference. But, yeah, they have a list of who was taken out in the name of national security or whatever.

David: And did they use that as an incentive for people to keep their mouth shut?

Corey: Yes, because everyone in the programs knows what happened, even though the general public is given a cover story.

David: So the implication is that no matter how high-falutin you think you are, how important you are, they'll snuff you like a candle the minute you step out of line.

Corey: Yeah, presidents, senators – it does not matter.

David: Well, that's a group you don't want to mess with. In the next clip here, we're going to be talking about Nordic secretaries and their role in helping to shape America's development of their own Secret Space Program. Let's take a look.

THE NORDIC AGENDA

William Tompkins: I could never get my secretary to admit that she was a Nordic, okay?

And everybody knew it, but she wouldn't accept [it]. But from what she would drop into conversations, essentially, she was a part of the Nordic Navy, like a commander in intelligence with a mission to support a specific program – the Apollo program – and support all of it, not just the first phase to go to the Moon, but second phase to build Navy stations on all of the planets that were habitable or their moons in the solar system, and then build bases on all of the 12 closest stars.

That was the Apollo mission.





Now, the two girls in engineering, the two Nordics, never in any way of that four years came up with anything that would bother the mission to be accomplished.

They were constantly pushing everybody to the side who were trying to stop the program from being implemented. Cover it up, change information, do it wrong – everything – all the way through the four years.

So we ended up . . . We roughly did four years. I roughly did four years in the Navy, and I roughly had slightly less than four years on Apollo. Now, part of my four years on Apollo was on Nova trucks.

And the Nova trucks were like 8 times the size of the Apollo, 10 times the size, depending on what you were . . . And they were trucks to haul all of the facility equipment that we needed to build a 20,000-man Naval station research center on the Moon. That's what we were supposed to be doing.

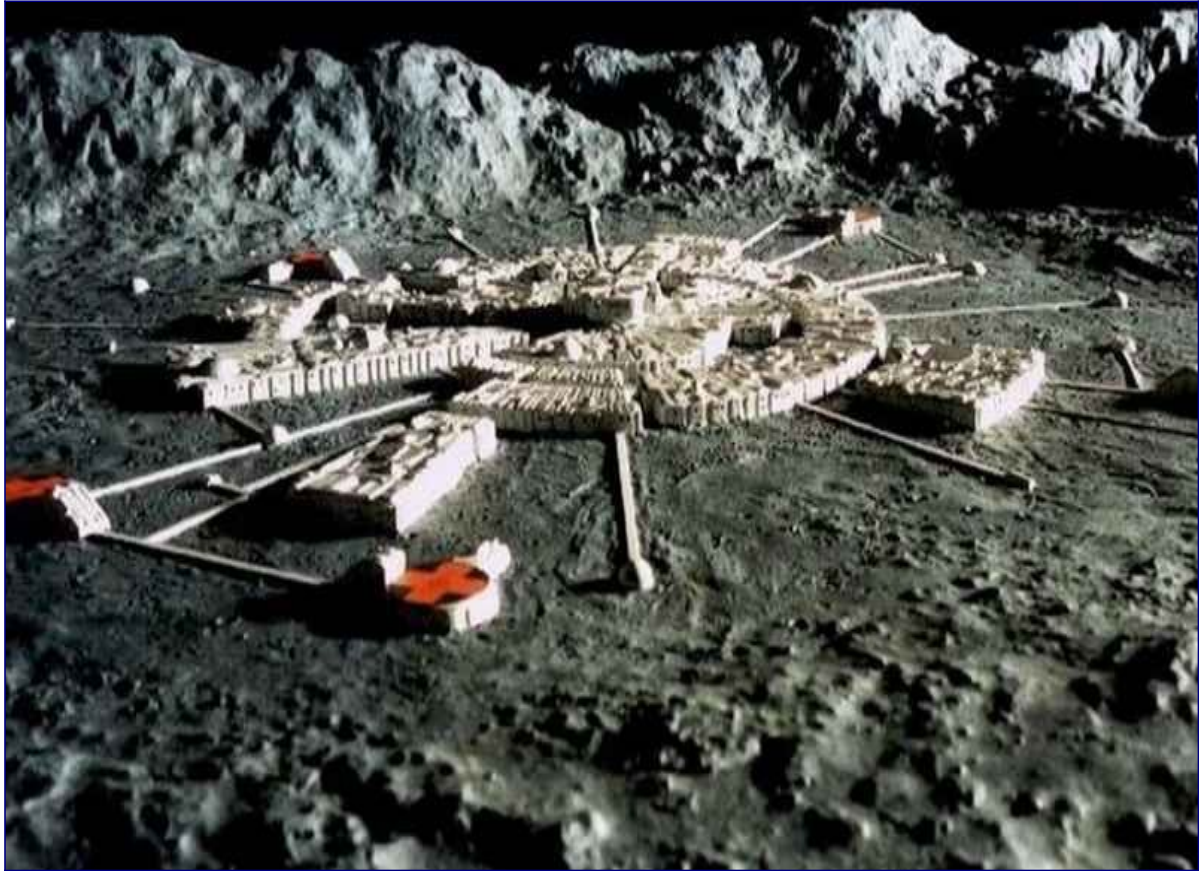
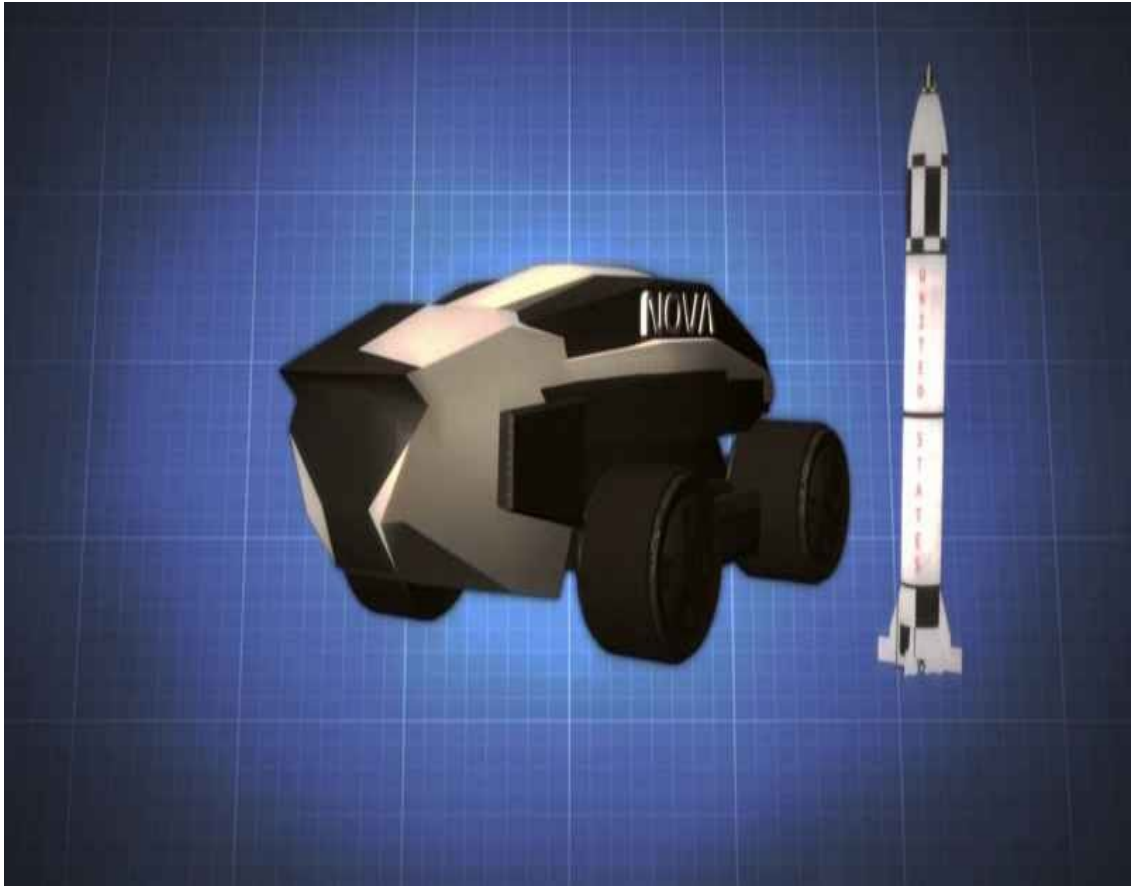

The mission to the Moon was to build these facilities, and all we did was get to the Moon.

And some guys gave us the finger and told us, “Don't come back! Okay, go ahead and finish a couple or three more of your missions, and don't come back.”

Well, these were the reptilians. So they were already there. We didn't know that.

And essentially, we got stopped a third [of the] way through the missions.



Now, the Nordic people . . . What are they here for, and who are they? And we didn't learn until much later there's boxes full of Nordics, okay? I mean, we got a whole box full of them, like maybe 100 different types, we know now. But back then, we just thought of one.

The two young ladies represented the Nordic civilization. And my girl turned out to be a Nordic Navy Lieutenant Commander with a specific contract and a specific mission to get the Apollo program

implemented – the whole program.

So you have to say that that group that she supported from out in the galaxy were the greatest thing that could happen to the planet.

Never did she ever come up with anything that threw cold water on any part of the program. She was always way ahead of everybody with how to fix it.

And she telepathically, continually threw stuff in my head. “Don't let them go that way, Bill. You know what we talked about. You got to fix it.”

And I have to say, I never had any type of relationship with a person like her till I got over to North American and then over to TRW.

And those girls also refused to say that they were Nordics, but they again were doing exactly the same thing as my secretary at Douglas on the Apollo. They were pushing those girls. [i] had two of them at North American. The one I got into . . . my secretary, administrative assistant in TRW.

So there, again, you're getting support from an individual that is probably part of the Nordic Navy, implementing an agenda, again.

They were at war with the reptilians way out there. And Solar Warden, of course, was our portion of that war.

And they were also at war with the insects, the praying mantis people, if you want to call him that.

And so we were fighting two of the really bad people collectively. We were going to be fighting with them, which the Nordics were already doing.

And the Nordics had lost one massive battle between their planet and another planet, which the reptilians had, and restructured again and then were back at war again.

We're talking about a whole lot of things that were elements in who are the Nordics. Who are these guys?

SOLAR WARDEN

THE SECRET SPACE PROGRAM



David: All right. Now, this is getting very interesting, because we're starting to cross over into a lot of the areas that you folks have said are the things that you want us to talk about the most. And so we're going to just tear right into this thing.

Now, first of all, it was very interesting that he talked about the Apollo missions having phases and that only Phase One was landing.

He talked about them building trucks and that there was a separate launch site for these trucks, and that their goal was to actually build these 20,000-person bases first on the Moon, then on other planets and their moons, and then 12 stars around our solar system.

That's a lot of information, and I just want to get your take on that before we go into all the rest of it.

Corey: Yeah, I may have actually visited one of those.

David: One of what?

Corey: Those installations in another star system, . . .

David: Ah!

Corey: . . . when I was taken through the portal to that moon that was around this gas giant that I described.

David: Right.

Corey: So this could be one of those bases in one of the local 13 stars.

David: Now, he said that the reptilians told us to buzz off when we got to the Moon and that, on the overt level, the Apollo missions were not continued.

But it definitely appears on a covert level that they were, and this might be one area in which **Tompkins** and the intel that he got hasn't given him the full perspective on what really happened. Would you agree with that?

Corey: Yes. Yeah. The information is always going to be skewed and elements redacted.

David: Now, he's talking about a Nordic Navy. And he gave us some very interesting information. It was a little awkwardly worded maybe for some, but he talked about there being a box of people, and that he said within the box we ultimately found out that there were 100 different types of Nordics.

Is that consistent with anything that you've heard?

Corey: The number isn't. I don't remember hearing that specific of a number, but, yes. There were many different types categorized. And they were slightly different in size and stature.

There was even one group that they were calling Nordics for a while, but they have the Nordic look, that they're about 8-feet tall, have a big forehead and six fingers. And they were putting them in that category for a while.

So that happens, just like there are tons of different beings out there that look similar to what we call the Grey.

David: Now, he describes that these Nordics had a navy and that the woman that was working with him as his secretary, or administrative assistant when he goes over to TRW, that in either case, they had a command designation within that military structure.

Is this consistent with anything that you've heard, that they have a sort of militarized structure to their organization?

Corey: Yes.

David: It is?

Corey: Yes.

David: Wow! Okay.

Corey: And also with the Inner Earth groups I was interacting with, seeing that - you know, their pilots that piloted the craft that we rode on to the Kuiper Belt and Venus – they were very military type.

David: Really?

Corey: Yeah. Yeah. They said they have their military groups or scientific groups. They don't all mesh together.

David: Now, he describes a war that was being fought between the Nordics and the reptilians. And I thought one of the really interesting things that he dropped on us was that there was a planet that the Nordics actually lost in this war because apparently there was an adjacent planet controlled by the reptilians. And they were fighting over this area.

The Nordics lost that war and then had to regroup and that apparently part of their regrouping was coming here and working with us.

Corey: That was probably one operation or mission out of their regrouping.

David: Right.

Corey: Yeah.

David: So how long has this war gone on? Has it been an ongoing war with the Nordics for, let's say, tens of thousands of years?

Corey: I really don't know how long they're been fighting, but I do know that there are wars out there that have been fought with the reptilians and their allies. And they've conquered planets.

And one of the groups that works with the reptilians is a Nordic-looking being that I described earlier with the big forehead and the six fingers. And all the intelligence was that they were a conquered race that was forced to work.

David: All right. Now, let's get right down into this idea of Nordics actually appearing within the military-industrial complex and taking on essentially support jobs but telepathically influencing people at those jobs.

Is it possible that these Nordics could actually be doing this? Could they actually appear on Earth and get these jobs and get the security clearance necessary to be in these positions?

Corey: Yes. Yeah. There are a number of them living on the surface of the Earth right now walking among us.

David: A number of them? Like as in how many would you . . .

Corey: I don't know. I mean, it's from different groups.

David: Okay.

Corey: The Anshar told me of thousands of years ago, one of the factions within their conglomerate of groups was banished to the caverns towards the surface and the surface of the planet.

David: Really?

Corey: Yeah.

David: How would one of these Nordic men or women be able to get into such a highly compartmentalized, highly classified thing? Wouldn't our government or the military-industrial complex be highly afraid of them because of the possibility of them either deceiving us or bringing intel back to their own group and then weaponizing it against us?

Corey: Yeah, and after a while, they found out that we were being deceived about some things that the Nordics – that we're calling them – did for operational security, you know? There were definite[ly] some deceptions that were given to us.

But for the most part, they were learning about the reptilian threat and the threat of their allies. And this group looks a lot like us. Basically, it's like a cousin coming to help a cousin.

David: The enemy of my enemy is my friend.

Corey: Yeah, yeah. But these people presented themselves as wanting us to get rid of our nukes, wanting us to become more loving and peaceful. And they just . . . They did not see as big of a threat from them as they did their enemy, the reptilian groups.

David: Right. One of the things that **Tompkins** is going into that's different from what you've said is he seems to be portraying these Nordics, at least in this part of the interview, as being essentially from outer space, from other worlds.

So what do you think is really going on here? Is this . . .

Corey: Well, it's a mixture.

David: Okay.

Corey: So I don't know what group he was in contact with. He could very well have been in contact with a non-terrestrial group.

David: Okay.

Corey: But the groups that I had contact with that fit this description claim to be created on this planet naturally and that this is their home.

David: Now, **Corey**, I want to get into something that's a really sensitive personal thing for you and that everybody who's watched the show, it's their favorite episode. And that is, when you had this mind-meld with Kaaree, the priestess of the Inner Earth, and you reach out your hands to her hands.



She offered you some kind of beverage that you declined. You didn't want to drink the drink.

Corey: The elixir of Isis.

David: Let's just talk a little bit about what she showed you, and does that corroborate in any way with what **Tompkins** just told us in this interview?

Corey: Yes. And she was connecting with me to focus on one small period in my youth. And as we regressed in the mind-meld to that time, I was seeing her life, too, throughout the same time periods, or here age, that matched mine.

David: Right.

Corey: And one of the things that I saw was a series of meetings that she had with military types. The suits looked . . . the material looked '40s, '50s era, and she was speaking with Russians, with English, Canadian, United States representatives of the military . . .

David: Wow!

Corey: . . . and assisting them. And they said that they assist them psychically. They assist them with some technology. So, yeah, there's definitely some crossovers.

David: All right. So now we're going to have another clip for you. And this is getting into some really interesting stuff in which **Tompkins** is going to be describing his own experience of understanding that abductions are taking place.

And we're also going to hear him describing what he knows personally about the Inner Earth. And this stuff absolutely blew my mind, because, **Corey**, there were some things he says here we're going to see that even go farther than what you've said to me before. And it rocked my world. So check it out. You're going to love this.

ABDUCTIONS AND THE INNER EARTH

William Tompkins: A lot of people have been abducted for years, and a lot of them are still being abducted. But we're into a situation where, what do we do now? How do we fix this? What are all the things we have to do to fix it?

There are ancient extraterrestrial facility people, if you want to call them that, who have been living underground in massive caverns for thousands of years.

The Earth itself is almost a honeycomb. It has millions of massive caverns.

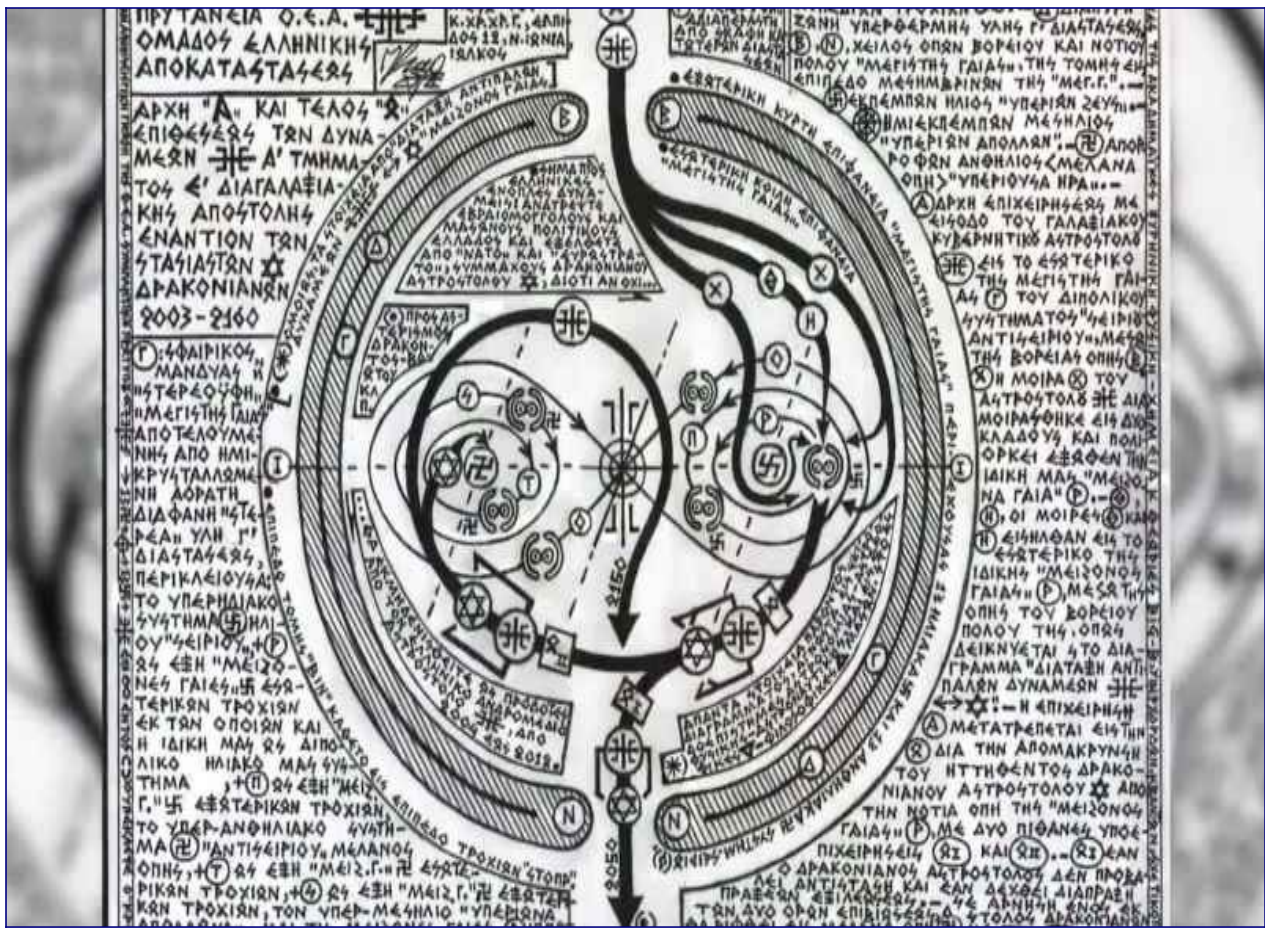

We look at the little caverns that they have over in New Mexico. And everybody goes there and they look at the cavern. They looked at the entrance of a guy's office. That's all they looked at.

When we're talking caverns Earth-wise, one of the caverns in Southern California goes way past into Oregon. And it goes east into Nevada. And it's one cavern. And there's caverns inside that cavern.

There's caverns inside of caverns, not just tunnels, but there's bubble caverns inside of caverns.

And some caverns are only a couple of miles long. But we are honeycombed.

And so these extraterrestrials came here, some of them before Noah built the raft. And some of them came after he built the raft, after the flood. But then there's been seven flood kinds of things that have happened here. We forget about that.



My uncle Walter had specifics of seven times when they took place. One was a situation where we had earthquakes on a continuous basis from Alaska to the South Pole all at the same time. Split the thing wide open, and so that caused all kinds of floods.

And so, yes, we have extraterrestrials here on the planet that are not just living in caverns. They have cities there. They have industry there. They have entertainment there.

They have essentially – maybe not like us – but they have, essentially, a full life there. They're born, they work, and they stop out of the picture.

And some of them have ridiculous short lives like humans. Others have in-betweens, living 2,000 or 3,000. Others don't stop living, period.



And these people sort of live together in the different caverns, but obviously with totally different agendas, totally different lives, and different missions.

Now, the Air Force got involved in this, and so they built their diggers, which are about half a mile long. And they'll dig a hole. It'll be 100 foot in diameter.

And we have trains throughout the United States, all over the country, even connecting to Nova Scotia, and some of them connecting to other countries locally, in this particular hemisphere. But the extraterrestrial tunnels are like 300 feet and close to 400 feet.



And these tunnels – the tunnel diggers dig at 2 to 3 miles an hour.

And they reduce all of the rock, all of the material – everything – down to microscopic material. and they spray it on that lining of the tunnel, which then turns to be almost glass, which then is electrically excited and becomes a lighted tunnel.

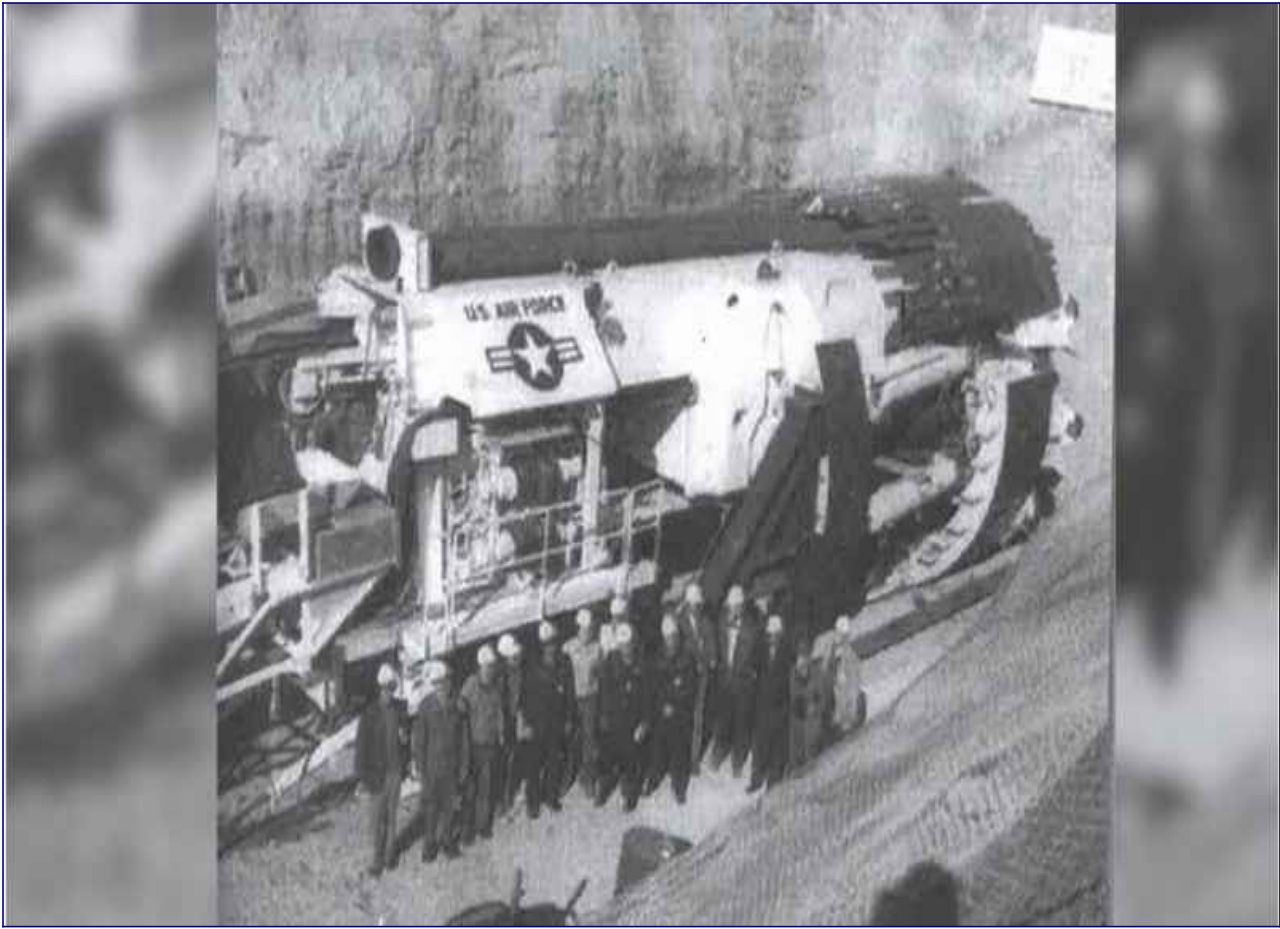

And these guys are running there 2 miles an hour, operating this tunnel, which then has subsonic vehicles operating on rail that don't leave the rail all over the planet – not just from ours, like from Washington, D.C., and the Pentagon, to the Air Force facilities at Vandenberg.

And so we've run into their tunnels digging ours, and we get not to graciously suggested to take another route.

And like in New Mexico, we have a large facility there, and we've had wars with some of the extraterrestrials that are there and wars with our military people and light skirmishes continually.

But then our people that are taken from their university laboratory to that facility, they get taken pretty fast. Like in one second they're there. And they take them inside. And they let them continue that particular research that they were doing at the university, except that now they are a slave.



They're not a business associate. They are a slave. So now we got slavery going [on] in these caverns all over your planet.

But then that's not such a big deal, because out in the galaxy, the different extraterrestrials, they do the same thing.

And they take the good guys, and they abduct them, take them to their facilities on their planet. Or they take them down underground of their original planet, and they do the same thing.

So again, we don't have just Earth as a laboratory. We have billions of laboratories on billions of stars out in the galaxy doing the same thing.

We're really low on the totem pole, unfortunately.

* * * * *

David: Phew! Heh! Okay. You saw it! I saw it. **Corey** saw it. This just happened. This is something that we are not fooling you. This is not a joke, okay? **Tompkins** is real.

I've interviewed him a bunch of times now. And **Corey**, how does it feel to see this stunning body of corroboration for everything that you've been telling us?

Corey: It's amazing.

David: He described the people inside the Earth as extraterrestrials. And he said that there are different types of lifespans, some of which live very short lives like ours, some of which live longer, and he said some of which live essentially indefinitely.

So let's just get your feedback first on that statement about them being extraterrestrials.



Corey: Well, I would agree that a very large contingent of extraterrestrials, many different types, have what we called “embassies” in caverns all across the planet.

But as I've given in my testimony, I recently had contact with a group, Inner Earth group, that claimed to have developed on this planet, which would not make them non-terrestrials.

David: Right. So some of these people may, in fact, be indigenous to Earth. It's just that they have evolved or they developed in these Inner Earth areas.

Corey: Right.

David: Okay. Now, another thing that I really was taken aback by that caused me shock when I saw this was his statement that there are millions of caverns. And then he actually used the word "honeycomb".

I just want to clarify for everybody watching that he was not prompted with your testimony. He never heard you refer to it as the honeycomb Earth. You had not seen "The Law of One", which also refers to it as a honeycomb Earth.

So we have three independent sources now all documented, in addition to others who've mentioned it that way to me privately – other insiders that don't want to come forward.

So let's just start with that. Would you agree that there are, in fact, millions of caverns inside the Earth?

Corey: Yes! Yes! The way the Earth developed, there was, I think, similar to a vascular system going through it, and as it cooled off, you know, of molten rock, and as it cooled off, it formed all kinds of caverns. And then the tectonic activity on the Earth, as crazy as it is, has created those as well.

David: Hmm. Now, we had some people write comments on an article I wrote recently talking about the Inner Earth, where they didn't understand why those caverns would be safe from things like giant earthquakes on the surface of the Earth.

Corey: Right. These are down towards more below, further down in the crust than most of the fault lines, except for the deepest fault lines.

David: Ah.

Corey: And then they do not normally, depending on their level of technological development – thus, different non-terrestrials that live different ages – you know, they're in different stages of development.

David: Right.

Corey: Some of the higher technological groups, it would not be as difficult for them to live close to fault lines, but most of this is very deep in the 20-to-40-mile range of the crust.

David: Right, so an earthquake's only going to jiggle up near the surface, and the shakes aren't even going to make it down that far to any significant level.

Corey: It jiggles all – yeah, the whole thing. Shock waves travel through the rock in both directions, but a lot of them, of the more technologically developed groups, have the technology to mitigate that.

David: Oh, like shock absorbers, basically.

Corey: Yeah, sort of.

David: Something like that.

Corey: Energetic.

David: Now, he also said – I just want to get your raw comment on this without interjecting my opinion – he mentioned a cavern that goes from California up past Oregon and then all the way over to Nevada that he says is one single, contiguous cavern.

Corey: Uh-huh.

David: That's a pretty shocking statement. What's your response to that?

Corey: Well, I've talked a little bit about the same cavern system. Part of it, we have submarines going in and out . . . going far inland into the United States, popping up in lakes.

David: Okay, so some of these caverns are not hollow and filled with air. They're going to have seawater in them, in some cases.

Corey: Yeah. It's a mixture. Depends on how the cavern is sealed off, how the cavern runs, as opposed to a cavern that's right next to it. So a lot of the times, they'll have one area that's water that they'll have

submarines in. They've dug through to another cavern area that is somewhat pressurized naturally, keeps the water out, and build out facilities.

David: All right. So another really disturbing aspect of this clip that we just saw is him describing what appears to be a variety of different types of slavery going on. He describes slavery inside the Earth. Humans being taken to other solar systems.

And you've covered on this in other episodes, and you also did it with George Noory on “Beyond Belief” here on Gaia. But could you touch on some of your feelings about his sentiments about the slave trade?

Corey: Yes, and he's either only reporting a small amount because it's so disturbing, or that's all he was briefed on.

David: Right.

Corey: But he was touching on, well, the abduction scenario, he touched on. But the people disappearing off the planet, that are just being abducted, . . . that, during a certain time period, were being abducted by non-terrestrials and were being taken outside of our star system for a slave trade.

Later on, we decided, “Hey, this is a commodity” - “we” being the Cabal-type groups. And they started obtaining and trading humans for technology and biological material.

David: So what can we do about this slave trade? It's a very disturbing thing for people. I can understand they might feel powerless. Is there anything that we can do to try to bring this to a halt and get freedom to happen for people on Earth?

Corey: Well, on our end, the most we can do is make people aware that it exists. You can't tackle a problem unless you're aware there is a problem. And, I mean, everyone's asleep. They've been mind controlled.

And this information's going to be very disturbing and very hard to accept for many of these people.

David: Right.

Corey: But to mitigate it, what people can do on this, is mainly just educate themselves and others about it so when this information does come out, people won't lay in bed and suck their thumbs.

David: Now, you also mentioned some messages that the Blue Avians gave you regarding what will happen to people who have been kept as slaves as we go through this shift and the Draco have been defeated.

And I believe this concerns certain breakaway groups.

Corey: Right, and there are some non-terrestrial groups and a couple breakaway groups that are assisting in this. The infiltrators that infiltrated the program, the galactic slave trade program, started putting tracking markers on their victims so that they could later track them down to wherever they went, no matter where in the galaxy or other galaxies, and send their allies in to retrieve them.

And then after they've been retrieved, they're in all different psychological states from what they've been through.

And the ancient Mayan group has been helping a lot of them recover and heal on one of their planets.

David: So in short, do you think that, as we get this breakdown of the negative, the Draco, being defeated, as we've discussed in other episodes, that there will be a widespread rescue and salvage operation for these people that have been brought into slavery?

Corey: That already has been ongoing.

David: Okay. So it's just important for people to hear then that something is being done and a lot of these people who might be enslaved now will be able to be freed as we go through this change.

Corey: Yes, and once they go through all the healing, they will be returned to our society, whatever state it's in at that time.

David: Wow. All right. Well, this has been really fascinating. I want to thank you for watching our show. This is certainly mind-blowing. After all this time, people say, "Oh, **Corey** has no validation." Well, what you've just seen here is a game changer.

And I encourage you to tell everybody you know about this, because now that we're bringing this all

together, maybe a lot of people who wouldn't have taken this seriously before are going to take a second look.

And we do need your help. We need as many people as possible to educate themselves about this. As **Corey** just said, it's vital to humanity's future that we no longer act as ostriches, that we have the awareness of what's really going on.

This is "[Cosmic Disclosure](#)". I'm here with **Corey Goode** and **William Tompkins**. I'm your host, [David Wilcock](#), and I thank you for watching.

Cosmic Disclosure: Empaths and Extraterrestrials with Clifford Stone

Season 5, Episode 13

[David Wilcock](#): Hi, I'm [David Wilcock](#), and you're watching "[Cosmic Disclosure](#)". I'm here with my co-host, **Corey Goode**, as we go down the rabbit hole.

Clifford Stone never rose above the rank of sergeant while he served in the military. That's an important point. But he was noticed by higher-ups in the military from the time he was a young boy, because of his empathic abilities, or, as he puts it, his ability to telepathically "interface" with the extraterrestrials.

When the military encountered extraterrestrial life forms, they entrusted **Clifford** to help with communication and facilitation with these entities. It turns out that there are many life forms and extraterrestrial species, just as **Corey** has been describing on our show.

Life in this universe is much more robust than we have been led to believe. Stone individually corroborates this notion.

So, ladies and gentlemen, without further ado, I give you **Clifford** Stone.

RECRUITING MR. STONE

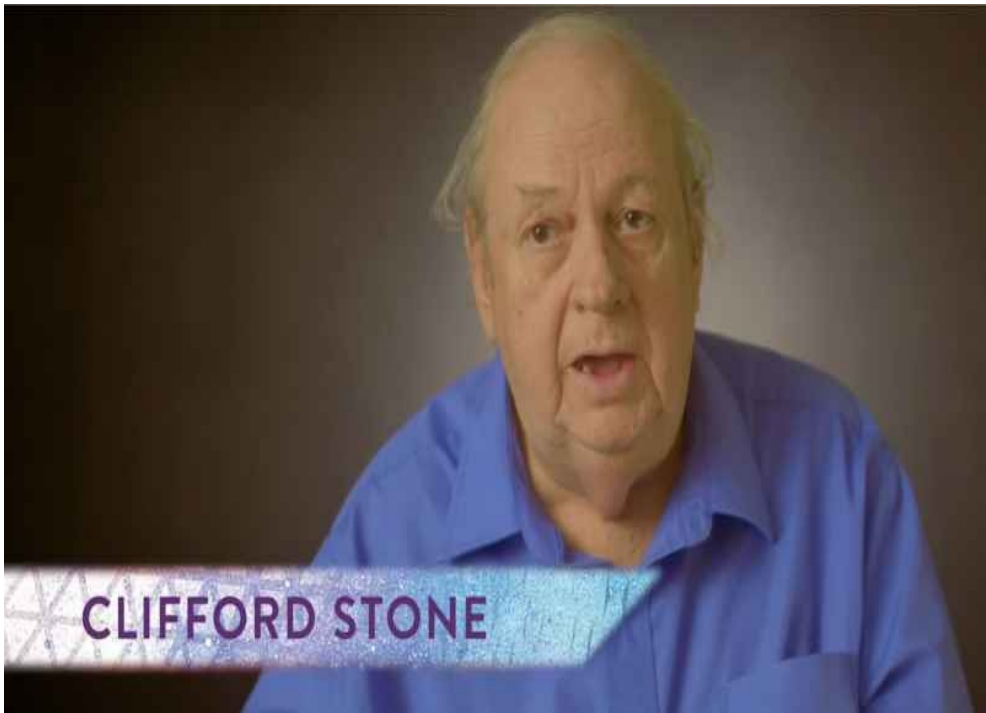

 **ORDER TO REPORT FOR INDUCTION**

The President of the United States,
To

LOCAL BOARD NO. _____
(Local Board Head)

(Date of mailing)

SELECTIVE SERVICE NO. _____

GREETING:

You are hereby ordered for induction into the Armed Forces of the United States, and to report
at _____
(Place of reporting)

on _____ at _____
(Date) (Hour)

for forwarding to an Armed Forces Induction Station.

(Member or clerk of Local Board)

IMPORTANT NOTICE
(Read Each Paragraph Carefully)

IF YOU HAVE HAD PREVIOUS MILITARY SERVICE, OR ARE NOW A MEMBER OF THE NATIONAL GUARD OR A RESERVE COMPONENT OF THE ARMED FORCES, BRING EVIDENCE WITH YOU. IF YOU WEAR GLASSES, BRING THEM. IF MARRIED, BRING PROOF OF YOUR MARRIAGE. IF YOU HAVE ANY PHYSICAL OR MENTAL CONDITION WHICH, IN YOUR OPINION, MAY DISQUALIFY YOU FOR SERVICE IN THE ARMED FORCES, BRING A PHYSICIAN'S CERTIFICATE DESCRIBING THAT CONDITION, IF NOT ALREADY FURNISHED TO YOUR LOCAL BOARD.

Valid documents are required to substantiate dependency claims in order to receive basic allowance for quarters. Be sure to take the following with you when reporting to the induction station. The documents will be returned to you. (a) FOR LAWFUL WIFE OR LEGITIMATE CHILD UNDER 21 YEARS OF AGE—original, certified copy or photostat of a certified copy of marriage certificate, child's birth certificate, or a public or church record of marriage issued over the signature and seal of the custodian of the church or public records; (b) FOR LEGALLY ADOPTED CHILD—certified court order of adoption; (c) FOR CHILD OF DIVORCED SERVICE MEMBER (child in custody of person other than claimant)—(1) Certified or photostatic copies of records from custodian of child indicating custodian's contribution for...

Clifford Stone: When I graduated in . . . it was first part of June, 1968, I got a notice from the draft board. And the draft board was telling me, “Greetings and salutations from your friends and neighbors. We need you to report for reconsideration at the Ashland, Kentucky, AFEES, Armed Forces Entrance Examination Station.”

And my mom was upset, says, “No”, you know. “I know you're going to get in the military, and you're going to wind up going to Vietnam.”

I said, “Mom, you don't have to worry about that. I'm medically disqualified. And it's still going to be the same.”

So I went there, and I passed all my written tests, you know, with flying colors, but I still had the medical problem.

There was a captain there that was the medical doctor, and he'd already told me. He says, “Well, you know you're going home.” He says, “I know that you'd like to go ahead and serve your country, but there's nothing we can do. You have medical issues, and you're not qualified for military service.”

We had this colonel who was visiting from the Washington DC, area – I'm going to put it that way – who went ahead and told the captain, “Look, go ahead -” and it was on Friday, and it was Fourth of July weekend - “take your family, go on home, and enjoy the Fourth of July weekend. I'll go ahead and finish up the ones here.”

Well, I was saved till last. Then he called me in, and he said, “You know, you have medical problems.”

I says, “Yes, sir.”

And he says, “Do you really want to go in?”

And I says, “Well, yes, sir. There's a lot of people that don't believe in this war. There's a lot of people that don't want to go. And I want to serve my country. And if I get to go, that's one less person that's going to have to go in my place.”

I said, "Right now, I feel every time somebody that doesn't want to go ends up going, that's a person going in my place. And if I hear that they get killed, then they got killed in my stead."

And he says, "Well, what if I fix it to where you get to go? You can go ahead and fight it at any time. All you have to do is go and tell them that you have this medical issue."

And I said, "You get me in, I won't fight it."

He says, "Well, remember, you got 179 days, once you're in. After you hit that 180 days, you're locked in. They're recognize the medical problems, but you're still in the service."

I went ahead. I got in. I hit up on staying in. I passed the 180 days, then I went to Fort Jackson, South Carolina.

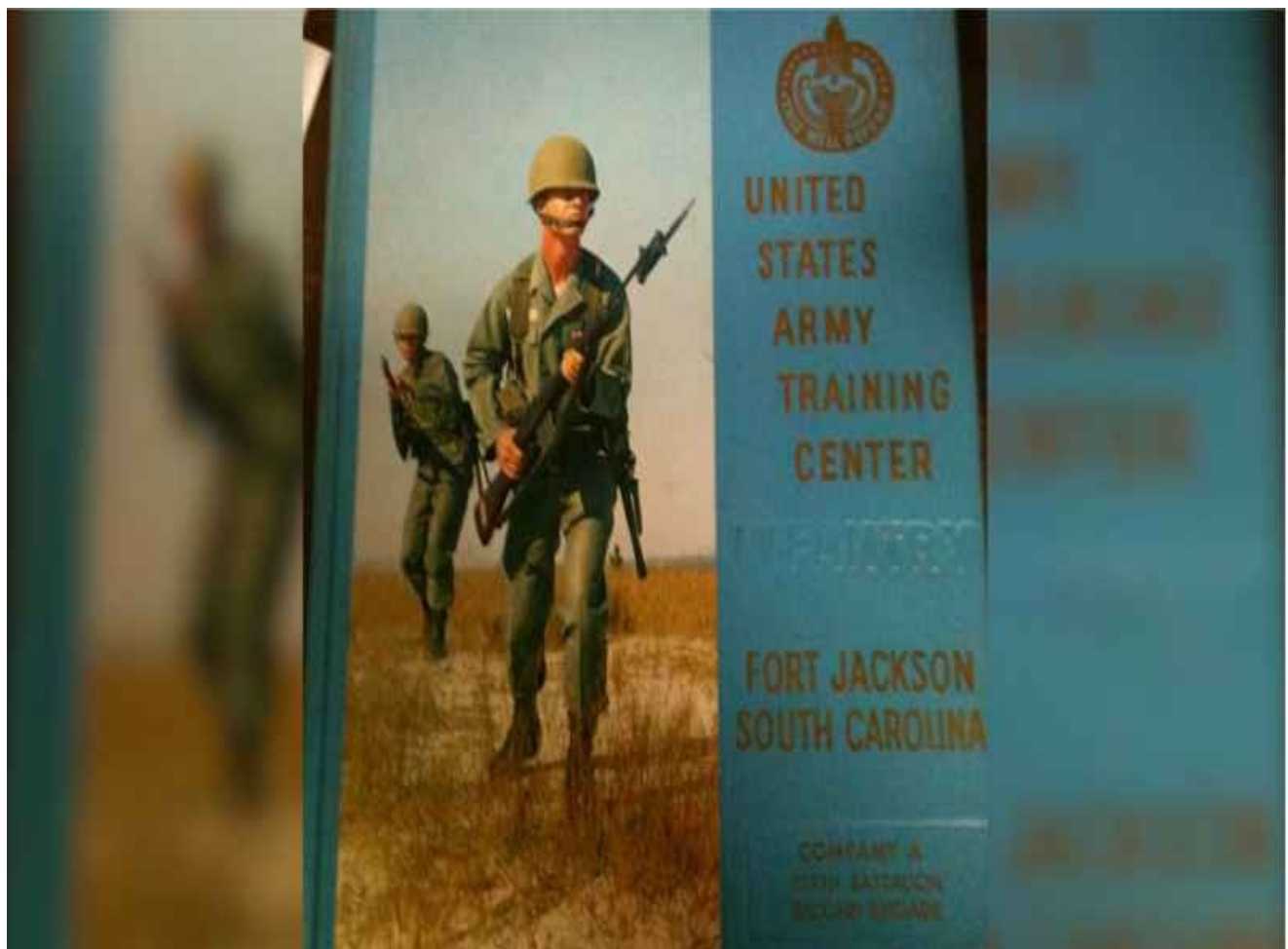

When I got to Fort Jackson, South Carolina, that was for my AIT. That's Advanced Individual Training, and I was going to be a clerk typist. Not the dream of my life, because I wanted to be a helicopter pilot, but that wasn't about to come to pass because of the medical situation.

But I went there, and I was one day in class, part of the second day in class. The next day, even before I got to class, they picked me out to go over and clean up the headquarters building and specifically the section that housed the intelligence section.

When I went in there, there was this guy there who was visiting, once again, allegedly from the Washington, DC, area. And he drummed up this conversation with me.

Well, my mom didn't raise no fools. I wasn't about to tell somebody I was interested in UFOs. And he went ahead and told me, he says, "Well, how do you feel about UFOs?"

And I said, "I don't know. I don't give them much thought."

He says, "Oh, come now. Everyone thinks about UFOs." He says, "Do you believe in them, or do you not believe in them?"

And I remember saying, "I really don't know. I haven't given it much thought."

He says, "I think you have." He says, "I personally believe in them." He says, "Here, I want to show you something."

And I looked at some of the documents and some of the records he has there. When I'm looking at it, I'm thinking, "This is not for me to see." Because I did not believe I had a security clearance.

I knew what Top Secret meant. And I knew, by looking at those records, I was violating the federal law of the United States – the espionage laws.

I did not know what the other words meant following Top Secret. Now I know that it is identifying it as documents under the Sensitive Compartmented Information Program or the Special Access programs.

I did not know that prior.

Now, I told him, “You know, I don't think I should be look at these. I don't have a security clearance.”

He told me, “Son, I am not showing you anything that I have not been told to show you.”

I know now that from a very early age, somehow, some way, they knew I was having this ongoing interaction with - and I prefer to call them - “our visitors”. And it was the one species, but I know other species were interacting in and around with this one species.

But only one of the entities was to follow me throughout life. But even at that, there was always that other interaction with the other entities.

The reason that I feel that the military permitted me to get in – it wasn't that they permitted me to get in. They have to choose people within the civilian sector that may not otherwise want to get into the military, that had this ongoing interrelation with “our visitors”.

What they used me for when they used me with UFOs, it was called “interfacing”. And that's where you actually carry on communication with “our visitors”, whether they're injured or whether they're okay and we're holding them until their kind come and pick them up.

But the whole situation is they won't talk to just anyone. They'll talk to these other people that have been specially selected.

And like I said earlier, you don't learn this. It's not something they can teach you. So they have to find people within the civilian sector, and then they have to entice these people to where they become willing to come into the military.

And a lot of times they may do this by appealing to your patriotic sense of duty or, in several cases, it's even monetary gain. And when it's monetary gain, every time I've seen that type of situation happen, it was because of family issues or otherwise people didn't want to be involved.

And these people are very difficult to find.

The reason I know that – when I got out of the military, there were only seven in the military, including me.

You know, when I got into the military, and after I went through AIT and everything, I got to my first duty station. And when I got to my first duty station, I was very concerned, because above all things – even though my record said I could type 72 words a minute – I would hunt and peck, and I'd be lucky if I could type four or five words a minute.

So when I got to my first duty station, which was the 36 Civil Affairs Company of the 96 Civil Affairs Group at Fort Lee, Virginia, I went in and gave my records to my First Sergeant. And I went ahead and I told him. I said, “You know, First Sergeant, I think you should know right not, I can't type.”

He looked at my records and he says, “But you can read?”

And I said, “Oh, yes, sir, “ or “Yes, First Sergeant, I can read. Not a problem there.”

And he took my records back in to the company commander. The company commander then came back out and said, “Well, tell me, son. Are you color blind by any chance?”

And I said, “No, sir.”

And he says, “Okay, just checking.” And he says, “What color of the uniform do you have on?” which I found to be a very strange question.

And I said, “Well, sir, it's the AG44 Army dress green uniform.”

“So you're telling me it's green?”

I said, “Yes, sir. It's green.”

He said, “That's all I want to know. I just wanted to make sure you wasn't color blind.” Nothing else was said.

Within a couple days, First Sergeant came back in and says, “Well, since you can't type, what we're going to do, we're going to send you to Ft. McClellan, Alabama, to attend the non-commissioned officers' nuclear biological chemical school.



Therefore, you'll be the NBC, a non-commissioned officer for our unit. And it's a three-week course.

And I said, “Okay, I don't mind doing that.”

And he says, “But, of course, along with that, you're going to be handling the communication equipment.”

And I thought, “Okay, fine. It's better than typing, because I can't type.”

So they went ahead, and they sent me to Fort McClellan. When I got there, we got to see some things,

which I never actually understood how it would tie in to NBC.

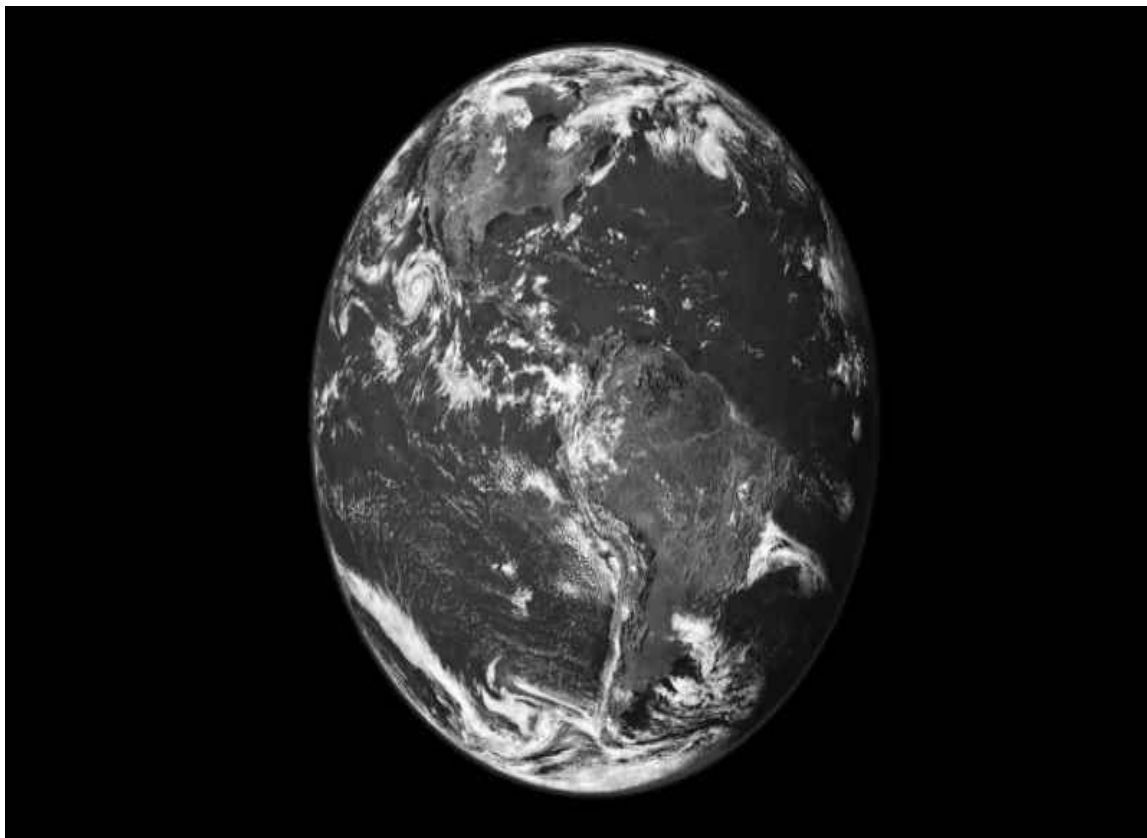

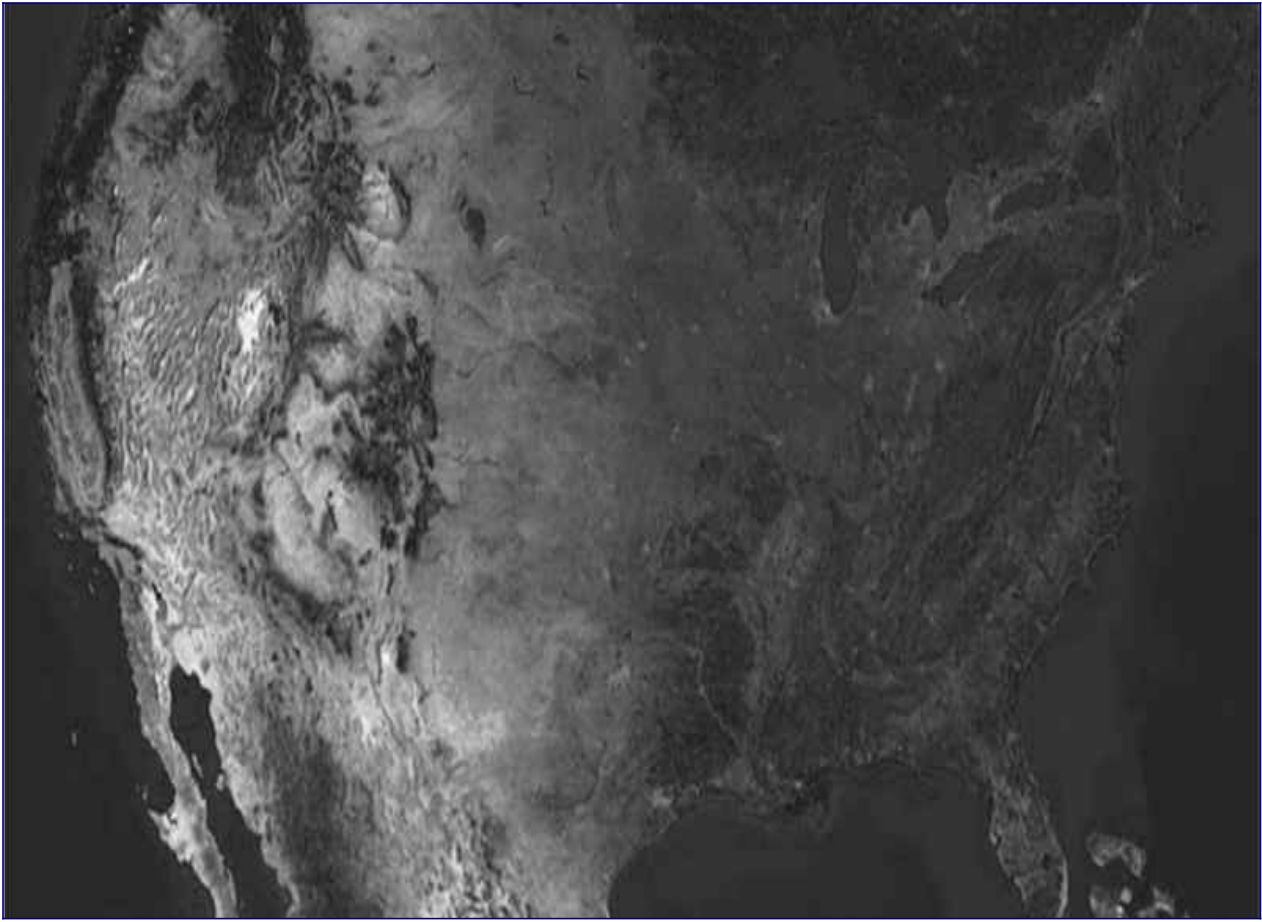

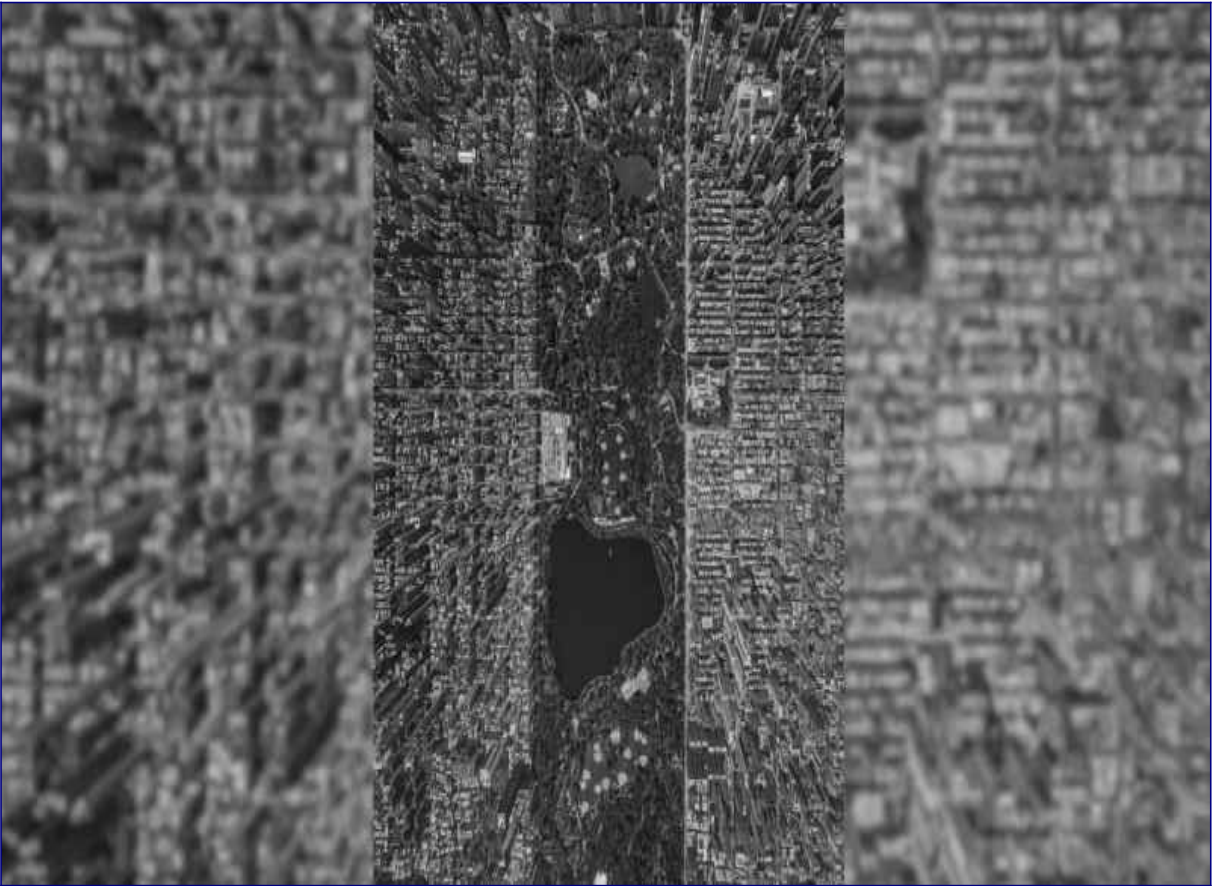
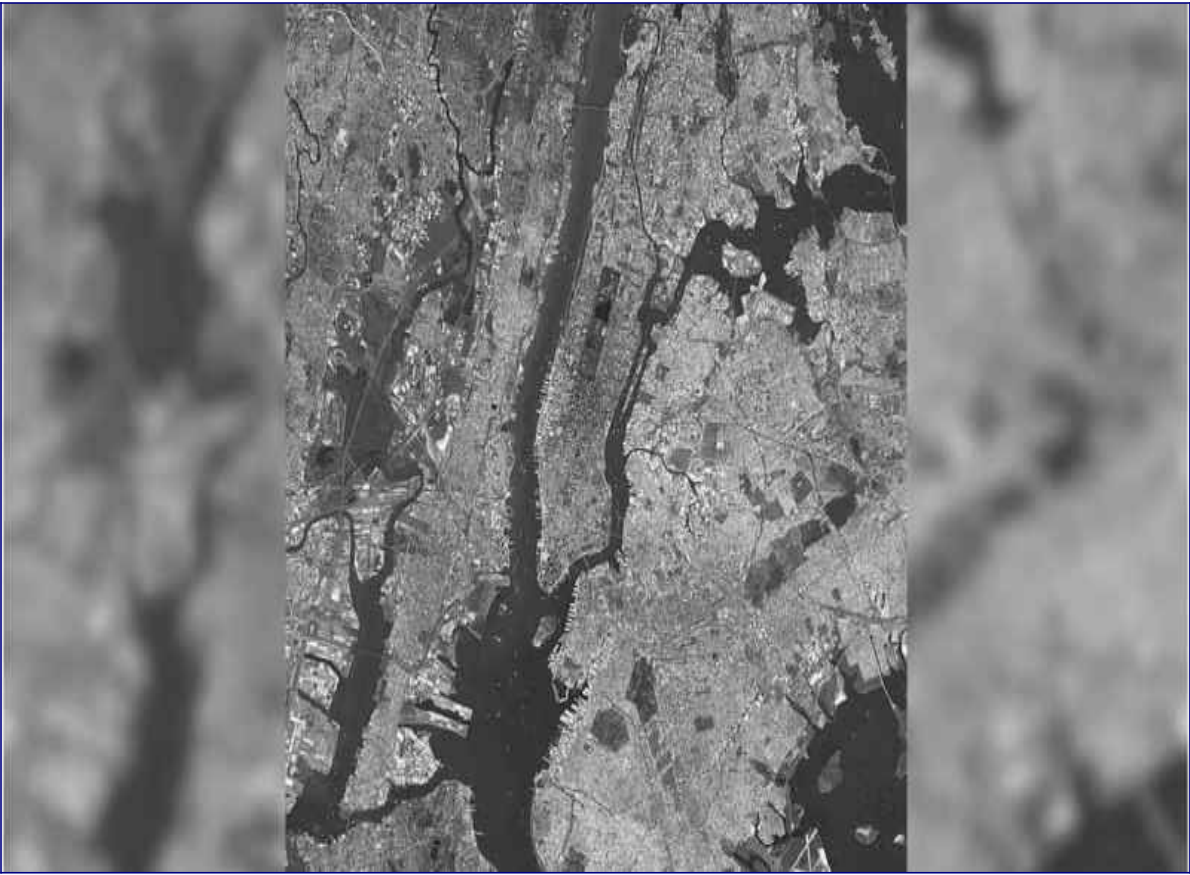

They showed this film, “This right here is from greater than 500 miles out in space, taken by a satellite.” Then they went ahead, “This is the United States taken greater than 500 miles out in space by a satellite.”

Then, “This is New York City taken by a satellite greater than 500 miles out in space.”

“This is Central Park, taken by a satellite greater than 500 miles out in space.”

“This is a man on a park bench looking at a newspaper taken from a satellite greater than 500 miles out in space.”



“This is the headlines of that newspaper taken from a satellite greater than 500 miles out in space.”The date was sometime in 1968. And, of course, this was, I think, February of '69.

But we wasn't supposed to have this type of technology. I know now, from my research and hitting up on my documentation with the NRO, that we had satellites capable of doing this all the way back to the mid-60s and probably earlier before that.

"All the News That's Fit to Print"

The New York Times

LATE CITY EDITION
Monday, November 21, 1967
From page 1, column 1, Page 16
64¢, Full U.S. rates on Page 16

VOL. CXXIII... No. 46,431 NEW YORK, WEDNESDAY, OCTOBER 21, 1968 19 CENTS

CITY TO ASK COURT FOR AID IN ENDING TEACHER DISPUTE

Board Seeks Writ to Block Interference With Return of 83 to Class '68

OTHER MOVES PLANNED

Mayor Will Close L.I.S. '67 If Union Allows the Other Schools to City to Open

By LARRY SHARON
The Board of Education, in an effort to end the 100-day school year, announced last night it would go to court to seek a writ to block the union's interference with the return of 83 teachers to their classrooms.

As the case nears the city court and it is expected that the writ will be granted, the board's attorneys will move to have the city sue the union for interfering with the return of a group of which each...

After the board's decision, the board's attorneys will move to have the city sue the union for interfering with the return of a group of which each...

The board will also seek a writ to block the union's interference with the return of a group of which each...

The board will also seek a writ to block the union's interference with the return of a group of which each...

The board will also seek a writ to block the union's interference with the return of a group of which each...

Apollo 7 Splashes Down After a 'Perfect Mission'

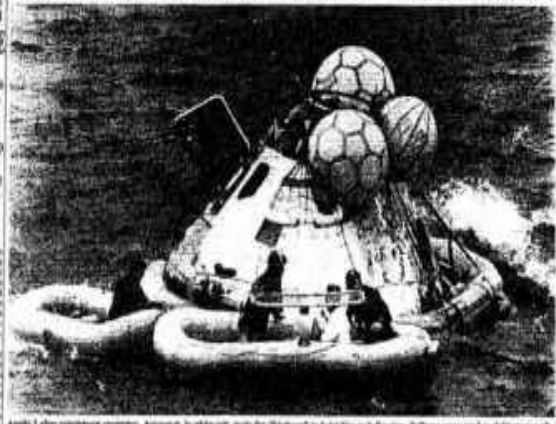

Apollo 7 after splashdown yesterday. Armstrong, in white suit, with the "Starliner" in lower line in background. Bullines were used in night operations.



Capt. Walter H. Butler Jr., of Navy, wearing Mid-Century 7, stands center, Air Force, and Walter Cunningham aboard the nuclear B-52 after recovery yesterday. At left is Dr. Donald Stauden, head of the NASA recovery team.

Defiance and Enthusiasm Spark Ocean Hill Schools

By THEO H. BUCHHEIM
The public schools in Ocean Hill refused their first day of school yesterday, and the defiance was met with a show of force by the police.

Humphrey Buried by Texas Outlook

Flint Long-Term Leader
In N. M. APPEAL
The Texas Outlook, a conservative newspaper, has announced that it will be moving to Dallas, Texas, in the near future.

Nixon Intensifies Shows at Hemphrey On Ohio Train Tour

In N. M. APPEAL
Richard Nixon's campaign manager, Fred Schwarz, announced that Nixon will intensify his campaign in Ohio during his train tour.

Freeing of 14 by U.S. Stirs Hanoi Rebuttal

By HERMAN GARDNER
The North Vietnamese government, in a rebuttal to the news that the United States had freed 14 prisoners of war, announced that it would not release any more prisoners until the United States had released all the prisoners it had captured.

THIEU DECLARES HE IS ASSISTING IN PEACE EFFORTS

Reply to Humphrey Calls for 'Good Reason to Believe' Hanoi Will Do Its Part
By THEO H. BUCHHEIM
The South Vietnamese government, in a reply to the news that the United States had freed 14 prisoners of war, announced that it would continue to assist in peace efforts.

EGYPT DEMANDS ISRAELI APOLOGY

President of the U. S. to Make Peace Proposal by End of Term Disputing
By THEO H. BUCHHEIM
The Egyptian government, in a demand for an apology from the Israeli government, announced that it would not accept any peace proposal until the Israeli government had apologized for the attack on the Egyptian embassy in Jerusalem.

U.S. Prepares Moon Shot in December

By THEO H. BUCHHEIM
The United States government, in a plan to launch a manned lunar mission, announced that it would launch the mission in December. The mission would be the first manned lunar mission since the Apollo 11 mission in July 1969.





But did not know it at that time. I was an innocent kid having no idea what I was being groomed for.

Anyhow, we finished school, and I met this guy. I knew him as Jack. He was a Spec. 5. And he worked for the US Army Security Agency.

And, of course, he was assigned to the National Security Agency.

And he said . . . You know, when I got ready to come back home, I found out my ticket had been stolen. And I'm wondering how am I going to get back home? How am I going to get back to my unit? And because, you know, Fort McClellan, Alabama, versus getting back to Fort Lee, Virginia.

And he says, "Well, you know, I'm there at Fort Belvoir. It's on the way. I'll go ahead, and you drive along with me. I got my own car here."

So we drove. And as we drove on home, we talked about various things – family, military, things of this sort. Then he brought up about he had an incident where he saw a UFO. And he started to prod me.



“Have you ever seen a UFO?” And I said, “Oh, I’ve seen things I couldn’t identify.” But, you know, I tried to keep it low key.

And he says, “Come on, you can tell me. We’re friends.” So I started telling him a little bit more.

Well, he dropped me off at my unit. And a couple of weeks later, he called and said, “Hey, listen. You’ve never been into Washington, DC, have you? You’ve never visited the Pentagon and some of the other nice to see places around here that tourists like to come visit.”

I went, “No.”

He says, “Well, why don’t I send a car to pick you up?”

Now remember, he’s a Spec 5. That’s an E-5 in the military. It’s the same as a Sergeant E-5. The

difference is, is that you're a specialist in your field with no command authority. Sergeant E-5 – they have command authority.

So they went ahead, and he's going to go ahead and send a staff car. Highly unusual, but I didn't think anything about it. Hey, NSA – what do I know?

But a car pulls up, complete with driver, and at my unit, and they're taking me away for the weekend, supposedly. And we went to Fort Belvoir, Virginia. I know that for a fact.



And we went to, I'm saying, it's the NSA headquarters is where we went. And we went to his office.

When we got there, well, Jack wasn't there. He had to go. He had an assignment he had to work on, but he'd be coming in later on. So one of the other guys who was there, who was supposed to be one of Jack's friends, says, "Hey, no problem. Why don't I take you to the Pentagon, because I understand

you've never visited the Pentagon? Why don't I take you over there and let you see what goes on over at the Pentagon, get to visit there?"



And he went ahead and he gave me a badge. He says, "Keep this badge on you at all times."

And they had a picture there. Then it had different color-coded sections on it that said where I was authorized to go and where I wasn't authorized to go.

And right at the bottom there was something on it that he stated, "That's very important because that opens up all the doors to you. But you have to stay right with me."

We go into the Pentagon. And when we go into the Pentagon, we go in, and he takes me around and shows me some of the offices. He shows me the one place where – "This, right here, is where they had the news conference in 1952 – July 29, 1952, dealing with the UFOs that was seen over Washington, DC."



And he says, “You're aware, of course, that 68 UFOs were picked up on the night of August 18, 1952?”

And I said, “Oh, yeah. I'm very aware of that.”

Then he says, “Well, you know, the most unique case, even though all these get all the publicity, was the night of July 19 and 20. That was the most unique one. Most people don't know anything about it. And he carried on the conversation, bits and pieces about it.

Then we get to an elevator. And he says, “Well, I'm going to show you the basement of this place.” He says, “People haven't seen this, and, of course, we have to harden”, which means that you prepare a building for a nuclear strike, “so we have to harden the Pentagon to make sure that people survive in the event of a nuclear attack.”

So he took me on down. And we got down . . . I don't know how many floors down.

But we got out and there was this little silver car. I mean, you couldn't tell which was the front, and which was the back other than where the seats were, and the seats were facing one direction.

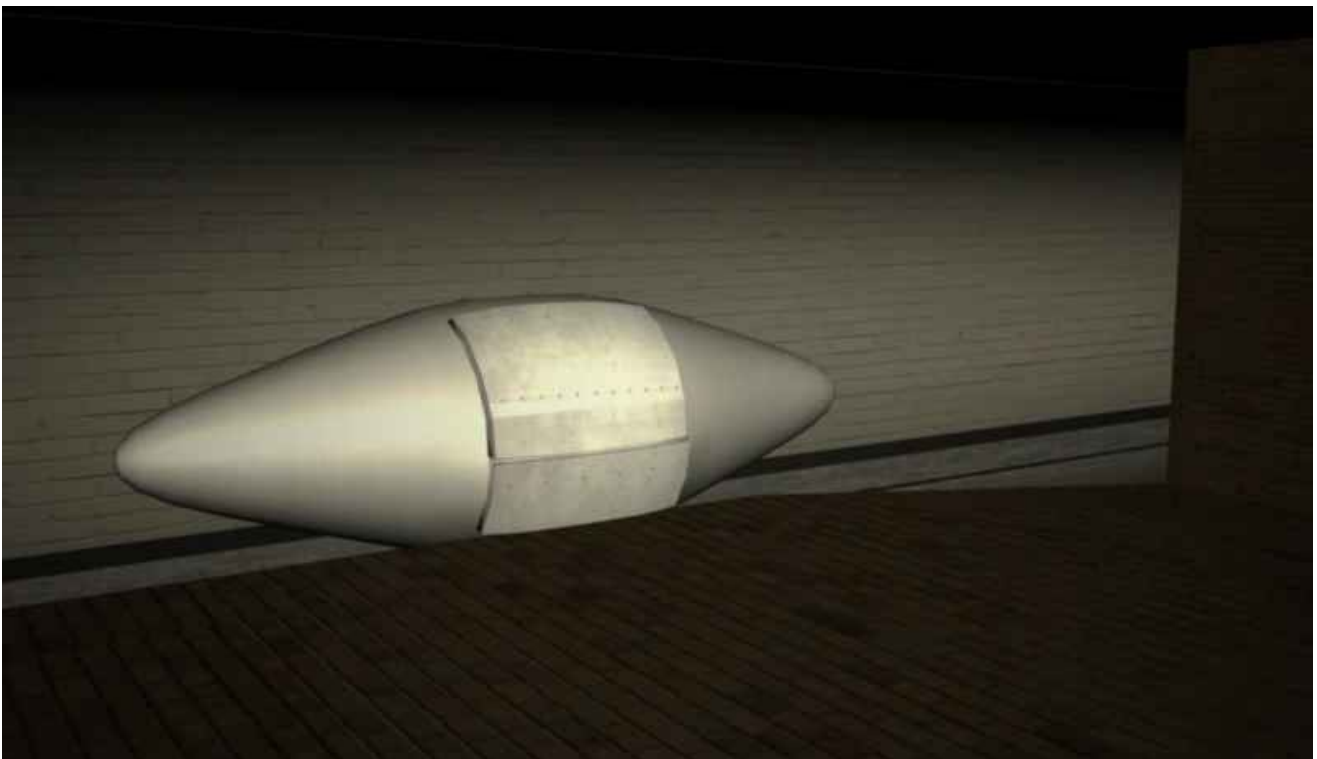

And we got into that, looked like a little bullet. We got into it, and he says, "This is called a monorail." He says, "It's not on a track." And he showed me where you have a little tube-like, and it drove on that. And it was electromatically driven.

So he went ahead, and we got in there. And I don't know how long we drove underneath there, but he was trying to tell me that the Pentagon's a mighty big place. So don't be concerned that we're driving for . . . in that little con . . . and there's no driver. You know where you're going and . . . I'm sure he had some way to control it, but I don't remember all of that about it.

I was just taken aback and fascinated, because this was the first time I'd seen anything like that.

But we got to this one place and there was this door on the side. We get out and we go into that door and there's this long corridor – no doors, just a long corridor. And this is underneath the, allegedly, underneath the Pentagon.

And I know we drove for at least 20 minutes.

But we went down that corridor, and he was telling me, "You know, a lot of things aren't the way they seem."

He says, "This looks just like it's a long corridor. You walk down to the end, there's nothing there. You have to turn around and come back. You can see the door at the other end."

And I said, "Yeah. What's your point?"

"Well, a lot of things aren't as they seem to be."

He tapped on the wall, and he says, "Solid wall, right?"

And I said, "Yeah." And I started to say, "What's your point?" Before I could say anything, he says, "It isn't necessarily solid." And he pushed me. And I go through the wall.

You know, there's nothing there, but yet, when I was there, it looked like it was just a solid wall.

And I go, “What the heck are you doing?” But before I could get up and say, “What the heck are you doing?” I notice I’m in a room. I turn around. When I turn around, there is this, what we call a field desk, which is nothing more than a little table.

And setting at the field desk, is what you would call your typical Grey.



And, once again – people get upset with it – I’m going to have to say he was about 4 ½, maybe even 5-foot tall. But he’s sitting there, and he’s got his hands up like this [on desk], and he’s looking directly at me.

On either side of him . . . and I’m not going to say black suit, it’s a dark suit, and they had dark glasses on. And they were standing there like this. [Standing up straight.] Not one word was said.

And I was the one that when I got up and turned around to see, “What the heck are you doing?” That’s what I said. I remember to this day. “What the heck you do . . . ?”

And I stopped right there because I saw this, and immediately it’s like a buzz saw going off in my head. I went down on my knees, and I went face down first. I remember that. That’s the last thing I remember.

I wake up. I'm back in Jack's office. I'm being told nothing happened. I must have dreamed it. No one took me any place. We had been there all along, and I seemed to be tired. And I must have just dozed off.

Jack never showed up. I was put back into the staff car, and I was drove back to my unit, being told that whatever mission Jack was on, it was going to be time consuming and it probably would be another week before you get to come back. Last contact with Jack.

The reason I think that that incident happened, it was part of the conditioning to get me in the frame of mind that I would understand there are many things that people aren't supposed to believe in, that is reality. And that I was going to have to play a role in it, whether I wanted to or not.

So I think it was part of the conditioning to get me conditioned to where I would accept it and, eventually, assure myself, within my own self, that I was doing this for the greater good of the country.

And I'll tell you, right now. All the time that I was involved in this stuff, I really felt that I was doing something that was for the greater good of the country until toward the end. And then I didn't feel that way.

* * * * *

David Wilcock: This is pretty intense stuff here. This is an origin story. And I don't know about you, **Corey**, but when I watch that clip, . . . anybody (who) is going to try to tell me that this guy is making this up . . .

Corey Goode: No.

David: I mean, some on.

Corey: There was nothing but genuineness coming . . .

David: And I don't know if you know this, **Corey**, but Sergeant Stone's son died as a result of him coming forward.

Corey: Yeah, I heard.

David: This guy has not profited off of his story. He came out in 2001 at the Disclosure Project. He's hardly done any events since then. He is not trying to go out there and make a name for himself.

He's obviously not getting any ego gratification off of telling these stories. And they haven't changed in the 20-some years that he's been out there publicly.

Corey: He's not the ego-centric type.

David: No, definitely not. You can clearly see, in the beginning of this interview, 1968 – the height of the Vietnam War. It really was remarkable to me his sense of personal honor and duty to his country that he wanted to go in the place of people who didn't want to go, that he felt personally responsible for those people's lives.

Corey: Yeah.

David: Now do you think that that quality is part of what made him empathic enough to do this intuitive communication?

Corey: That's one of those chicken or the egg kind of questions. You know, nature or nurture. These personality types are heavily searched for. They are extremely valuable. And he didn't say it this way, but he is what they would call an intuitive empath.

And this ability that intuitive empaths have allows the military types to interface or communicate with beings that don't use words, that have left language behind, you know, eons ago.

And, you know, they're not going to be able to sit there and doodle questions back and forth on a notepad.

David: Yeah. I thought that was one of the really fascinating aspects of corroboration with your testimony that we're getting out of Sergeant **Clifford** Stone here. The simple fact that it is such a rarity that the extraterrestrials will find anyone who they actually want to speak to.

Corey: Right.

David: Now, he also mentioned in there that he had a medical issue that would prevent him from going into the military. And I just want to clarify that he didn't ever say what it was. It was a personal private

matter.

But it sounds like the fix was in on him. I mean, would you agree with that that this is something he'd been targeted for?

Corey: Yes. The military-industrial complex, whatever you want to call them, they are tracking just about all of these visitor craft that come. And, more than likely, when he was young, and one of these craft had come and visited him, some time after it left, he was probably re-abducted by the military to be questioned about the relationship and what all happened with his visit.

And at that point, you're on their radar. Even if they don't come and re-abduct you, they know the people that are being visited.

David: All right. So let's now talk about how he gets activated, and they throw him into this very bizarre job, but it's in Washington, DC. And on the second day, he has this official, who's supposedly only a Spec 5, that comes in and starts trying to make small talk with him about UFOs.

This very clearly looks like it was a setup. Do you think that the whole job of him going there was just a setup?

Corey: Yeah.

David: That they sent him there to have that guy approach him?

Corey: Yes. That's exactly what happened. They . . . And in the military, people just don't nonchalantly kick back and say, "What do you think about UFOs?"

David: Right.

Corey: It's just like how pilots are. And like American Airlines, you're not going to see one of them walking around with their peers talking about UFOs. It's taboo.

David: Is it common for potential insiders to be approached in a manner like this with somebody who has documents in hand that are highly classified and then just tell you not to freak out, that you're authorized to see these documents if they want somebody that badly?

Corey: Yes. And all it takes is a person higher up clearing a person to see documents that are from Special Access Programs (SAP).

David: Right. So are you familiar with other people having a system similar to this happen to them, in terms of getting brought in where, first of all, it's very strange? A guy who's only a Spec 5 has the rank to be able to go right into the Pentagon. And then the whole thing about him being given a special badge and being able to just go right in.

Corey: Yeah. He had to be accompanied.

David: Right.

Corey: Yeah.

David: Is that . . . and then him going down through this long elevator for, God knows how long, and reaching . . . What was your feeling about him getting to that little craft that he described, this little egg-shaped thing where it looked the same on both sides?

Corey: It's a train, a transit system – the underground transit system.

David: So his description is consistent with what you have heard and seen?

Corey: Yes. And that sounds like one of the smaller trams that brings them to different areas within a facility.

David: So he takes this ride, and we have something that sounds a lot like [British accent] “Platform 9 ¾” in Harry Potter. Is there maybe some kind of hologram technology, a projection that makes it look like a wall? What do you think that was?

Corey: Yeah. They've used holographic technology, and holograms within fields that they called “hard light” that actually had . . .

David: Oh?

Corey: You know, you could knock on it. You could touch it. Or it could be programmed to be electrical.

David: So it's totally within the bounds of things that you've experienced that his story could be, in fact, genuine.

Corey: Nothing he said raised my eyebrows.

David: So he goes through that wall that's seemingly solid, and then he is seated in front of a Grey that he said was 4 ½ to 5-feet tall. And you noticed there was some reluctance there, in terms of him obviously thinking that our viewers are going to expect Greys to maybe be more like three feet tall.

Corey: Yeah. There are a lot of different types of beings that a lot of people in the UFO community put the “Grey stamp” on. They have a lot of different looks. They come from totally different areas. They're unrelated, but they look very similar.

David: Now, he reported going in front of this Grey that's got these two guys on either side and then having a feeling like a buzz saw inside his mind that actually causes him to pitch forward and fall to the ground. Do you think that's something that they Grey was able to do telepathically?

Corey: It sounds like it was an invasive interface attempt. You know, he wasn't sitting there, opened, indicating that he was ready to interface.

Some of the beings are . . . They're very, very, very powerful, psychically. And they just reach in, and they just grab your mind.

David: All right, now another thing that I thought was really interesting, that there was statements about a satellite 500 miles away from the Earth, and he's shown a series of images in which the zoom keeps going further and further from the Earth, to America, to, I believe it was Long Island, and then a guy on a park bench, and then the headline on the newspaper.

Are you aware of there being perhaps NRO technologies like this in the 1960s?

Corey: Oh, yeah. They've had this for a long time. And the distance he gives of most of the secret military space program objects are further than 400 miles from the Earth.

David: Right. so these are not geostationary satellites at all.

Corey: No, they can be tasked to go to different areas.

David: Right.

Corey: Yeah.

David: All right. Well, what we're going to do now is we're going to take you right into the next really fascinating clip that's directly relevant to the one you just saw from **Clifford** Stone. And this was his first example of where he got to see a UFO at Indiantown Gap.

This is very interesting stuff. So take a look.

INDIANTOWN GAP UFO

Clifford Stone: Now the next thing that involves something of a UFO nature, we were at Indiantown Gap, and we were on a field training exercise. They call it FTX.



So we went to Indiantown Gap. We set up. I had my Deuce and a Half, and I drove my Deuce and a Half.

I had my switchboard in the back of the Deuce and a Half. And I had my field phones that I had to set up to the various locations outside and I handled the switchboard.



And I had two prick-25's. Those are field radios, backpack radios.

So I had those there. One was for the group push – what we'd call battalion push, really. And the other one was for the company push.

So, you know, you had mock traffic and all this stuff that you recorded, like, if it was a real situation.

But a little after midnight we got a call that there was a crash of an aircraft there on the reservation of Indiantown Gap, and that they already had a response team there on station, but they needed a backup response unit to go out there.

I disconnected my field phones, because there wasn't time to pick them all up, and they would get somebody else to move in there. But I did that, and we moved on out.

There were three jeeps and four Deuce and a Halfs – 2 ½ ton trucks – to the best of my recollection. That's the best I can remember.

We went out, and as we approached the area, we were in blackout dry, which means we had no lights on or nothing, but then we saw this area lit up, with these big powerful – I think they call them light-alls – shining down into this little area where the Earth had been raised up a little.



And there was like this hill-shaped craft embedded at about a 30°~40° angle into the ground. You could only see the tail end of it.

So as we approach it, I'm wondering, "What the heck is that?" But now they'd already told us that it was an experimental aircraft.

And, as we got closer, I wasn't thinking no more. "Well, it could be an experimental aircraft." And I wasn't thinking too much. You know, I was thinking, "Okay, well, it could be a delta wing aircraft swept back – anything like that."



But when I got there, as soon as I got out, the guy that I always called the Colonel – this would be my actual first interaction with him.

He went ahead and he told me, "Son, do you have a Geiger counter?" And I said, "I got a APD 27."

And he says, "That'll work. I need a surface reading on this craft."

I said, "Do you think there's radioactive material on this aircraft?"

And he says, "We have reason to believe that there may be."

And I went ahead and said, "Okay." So I got the APD 27, the military Geiger counter, out.

And he told me, "I want you to walk towards the craft. Go up to the berm of the area where it dug in,

and try to get a reading as close to the center of the craft as possible.” And I said, “Okay.”

And he said, “But every couple feet, you go ahead and yell out what type of reading you're getting.”

And while I did this, I'd go ahead, and I'd get closer. And it was a little higher than background radiation, but not a whole lot. Then I got up to the berm. And when I got to the berm, I looked down.

[Emotional response] And when I looked down, there was this . . . It had a canopy on it. And there was this kidney-shaped hatch, for a better word, that was right up against the canopy, but opens to the side. And halfway out was this little creature. Once again, typical Grey.

And, you know, I can't tell you whether it was 3-foot, 4-foot, 5-foot, but [emotional response] it was half out and half in, and I could tell that it was dead.

And I started to say, [emotional] “Excuse me. I need an officer up here.”

And he says, “Just tell us what you see, son.”

And I kept saying back to them, “You know what? You don't understand! I need an officer up here!”
[Emotional]

And he said, “Just tell us what you see, son.”

And I said [emotional], “Well, what I'm seeing . . . it's not from this world, and you guys know that.” I said, “Why the hell are we lying? Why are we telling people that these things aren't happening?”

I said, “What do you want me to do now? I need an officer up here.”

And he said, “It's okay, son. Come on back down.”

And I went ahead. I turned around, and I walked back down. And when I walked on back down, I looked the guy that I called the Colonel right in the face, and I said, “What the hell are we doing here?” I said, “You know, there could be others on there hurt.”

And he says, “We'll take care of it. You get back in your Deuce and a Half, and you man your switchboard.”

There's no phones connected up, no nothing. I got back there, and I know it was winter, because I had my field jacket on. It was cold, and the only thing I had for a heater back there was a Coleman lantern. But, you know, I got back there.

The next day, when it was daylight, I looked out, and I saw them moving the craft. And it was a hill-shaped craft.

They put it on back of . . . we called it a lowboy – a 18-wheeler. It's just a flatbed.



We covered it with a tarp, and we moved it out. I have no idea where it went. Then we went back.

We were told that it was an experimental UNMANNED craft, which you didn't hear of drones at that time. And that was the end of it, but the situation, the whole matter, was classified.

No one was to ever talk about it.

Not everybody is trained or has knowledge of what to do or to have any interaction with “our visitors”. And like I say, the people who they [military] need to do this [interface with the “visitors”], they have to find in the civilian sector.

So I think I was the closest thing to that that they had there. So they went ahead and called us in, because they needed the one person, and that was me.

And, see, you feel things. And when I approached, I was feelings things. That's . . . I guess, that's why I get emotional about it.

It's not just looking down there and seeing a little dead guy. You're feeling . . . you're feeling pain. You're feeling loss. You're feeling suffering. You're feeling fear. But it's not like fear that you're going to feel as an individual.

It's just like 1,000 pictures running through your mind that you can see. But the emotions attached to those pictures, they're all there.

* * * * *

David: All right. Well, that's some pretty intense stuff there. Now, **Corey**, Indiantown Gap . . . If it's a reservation, I assume that there could be some pretty wide open spaces, some pretty empty areas, in which something like this could happen. And they could kind of swoop in, and not too many people would know about it.

Corey: Some Indian reservations are used. They have installations hidden on various Indian reser . . .

David: Oh, so do you think it's possible that there could be, like, a joint human-extraterrestrial base or maybe an extraterrestrial base around that reservation, and maybe they crashed because they were close to where they would come in?

Corey: I have been informed many times . . .

David: Oh, really?

Corey: . . . that they have installations on Indian reservations in areas that are secluded.

David: Interesting. So you have Stone here, and some skeptics might try to attack him for this or think that he has an ego or something when he says that the whole reason why that detachment was brought out – because they already had people managing the situation, and then his detachment gets brought out. Do you think it is true that that could have all been just because of him?

Corey: Them calling in reinforcements?

David: Mm-hm.

Corey: That part was just for him – to get him in.

David: So why would they send a kid out there by himself with a Geiger counter, ostensibly to take radiation readings, but then he walks up and he sees this dead extraterrestrial body? What's the objective of doing that to him?

Corey: They had checked the radiation long before they called in for backup. They already knew what all the radiation readings were. It had nothing to do with radiation.

What it had to do . . . It was a kind of a controlled test, to send him up, get his reaction, and also to see if he detected any life forms that were, you know, still alive.

David: So why do you think, when he keeps calling out, “I need an officer. I need an officer”, that they're telling him just to yell out what he sees? Are they gauging his stress – how much stress can he handle in that situation? Will he break down?

Corey: Yes. They're judging how much stress he's having. They're reading every single thing – his body – everything about him. You know, not all people that have the ability to interface are meant to do so. Some people just don't have the psyche to deal with it.

So this was a major test to see how he reacted. How he did in the days after. And they watched him very closely. And if he fit the bill, then they're like, “Okay, he's an asset now.”

David: Well, and he also said . . . He got very emotional and said, “Why aren't we telling people about this? If this stuff is real, why don't we know?”

Corey: That's a pretty common response.

David: Do you think that in the subsequent days after this that they'd check to see if he tries to blow the whistle . . .

Corey: Oh, yeah. Oh, yeah.

David: . . . or tell somebody?

Corey: Oh, yeah.

David: So they're also gauging his silence.

Corey: Yeah. They were watching him very closely and judging everything that he did, said, everything that happened with the people around him, in the context of how it related to the craft and the being that they exposed him to.

David: Now, he also described seeing what seemed like a flash-forward image of a whole bunch of pictures. He mentioned, like, 1,000 different thought forms, each of which has very intense emotions associated with them, like pain. And it sound from his description as if it was really fast . . .

Corey: Yeah.

David: . . . just a very intense, almost overwhelming, experience.

Corey: Yes. And most likely that being that had died . . . When someone or a being dies, there's still residual energy left. And he may have been picking up on that. Everything that that creature felt as it was crashing or afterwards as it was dying – a lot of that residual is in that area. And he walked into that residual field.

David: Have you experienced this sort of flip-book, 1,000 pictures with emotions, type of experience like what he's describing?

Corey: Oh, yeah. Yeah. When you interface, you're not getting words back and forth. You're getting smells, tastes, images. I mean, it's . . . And you have to piece it together in a way to where you can communicate back and forth and turn those experiences – the smells, tastes – into words to report back to the people that are counting on you to interface with the being.

David: Hmm. Well, this is just the beginning of how Stone's testimony lines up so well with yours. But obviously, as we're seeing here, there is a great deal of crossover.

And once again, I believe Sgt. **Clifford** Stone was one of the most intense Disclosure Project witnesses, because people always say, “Oh, come on. The government isn't picking up these UFOs.”

But clearly you're getting a boots on the ground, very detailed testimony of someone who actually was doing this professionally in the military.

Coming up next time on “[Cosmic Disclosure](#)”, we're going to have more of this fascinating content for you to explore with us here. And we'll see you next time. Thank you for watching.

Cosmic Disclosure: Clifford Stone Bio

Season 5, Episode 14

David Wilcock: I'm glad you could make it. I'm **David Wilcock**. And you are about to see a biographical sketch of Sergeant **Clifford** Stone, a man who joined the military around the time of the Vietnam War. He was really gung ho about getting into the service to try to serve his country.

Little did he know the wild adventure that he was going to end up on involving UFO crash retrievals, and how this testimony now is being brought forward by us to help directly validate many of the things that **Corey Goode** has been revealing on our show, “[Cosmic Disclosure](#)”.

So now you're going to get to see an insider's look at the incredible career of Sgt. **Clifford** Stone. Check it out.

* * * * *

Clifford Stone: When the children showed up, they would go ahead and they would talk to me. They even helped me with my homework. But they cautioned me about one thing: Don't tell others about us because they can't see us.

I could see them like I can see you; you can see me. Looked like typical children – boys and girls. Now one guy, he was like a little blonde boy, he was the one that was closest to me.

We'd go ahead, joke, and if I had no one else to play with, they'd play with me, you know? But to me, they were just children.

My mom and dad, and some other people, “Oh, they're imaginary friends.” I knew the difference between imaginary friends and what I was seeing, but I figured, you know, grown ups are never going to understand.

So I went ahead, and everything went real good. Then one day, I found this little bird that had fallen out of its nest. I grabbed the little bird, and I took it home, just like any other child. If you have a cut, you hold the cut underneath the faucet, and it washes the blood away.

When the little bird fell out of the tree, it broke its beak. And to me - it was squeaking – but to me that was screaming and it was in pain.

So I went ahead, put it underneath the faucet trying to stop the blood, and naturally I killed it. And my childish-like mind, it was like I murdered someone.

I thought about the bird will never see its family again. The mom and dad's going to be worried, never knowing what's happening.

Then the little boy, he showed up. Only he wasn't the little boy no more. He had like a one piece, silver-like suit, and he had this shocked expression on his face that was no longer human. And he was looking at me and literally I could hear it in my mind. But it's just like you and I talking right now.

He was telling me, “Why do you feel that way? Why don't I feel that way? Why is it that you mourn this little bird? It was just a little bird. Why are you feeling the way you feel? Why such a deep sorrow and sadness over this?”

And he didn't like the feeling, but, you know, he went ahead and said this.

And he says, “What is the water in your eyes?” He couldn't understand me crying. And I didn't know what to say to him, but at that point, it was no longer about worrying about the little bird or anything, it was total fear. Because here was what I always thought was the little boy, no longer was the little boy.

And I ran and I tried to hide. I ran. I hid behind the sofa, because it was set catty-corner. And I'd get

behind it.

And it was like he showed up there, let me know, “I'm right here”. The last place I hid was between the sink and the refrigerator. And I found – I can tell you and people don't like this, but, hey, the truth's the truth – like three bony fingers and an opposable bony thumb scratching me on my head as though to say, “You can run and hide, but you can't escape.”

Then my aunt – my mom was in the hospital at that time – but my aunt, Aunt Lynn, she was taking care of us. And she made me sit in this chair, because she thought I was being mean. And she thought I was out of control, so she made me sit in it, and I didn't want to sit in that chair. I had to go find another place to hide.

But eventually my friend came back to me. And now he looked like a little child, but I knew he wasn't a little child. I knew the truth now. There was something more to this.

And very carefully, very gently, he tried to make it to where he got back into my life and tried to reassure me that nothing evil is going on, nothing evil is going to happen to me, that they mean me no harm, and explained to me, “Look, we select people from among your own species. Throughout life, we follow these people, and we learn about your culture, [emotional] from the life events in your life. And we want to learn from you. And I chose you.

“Our lifespan is a little more than 300 years. I will live to mourn your death.” He said, “but I will learn a lot of wonderful things about your culture and your people from you.”

And I hate saying this, but I'm going to say it anyhow, because I think it's so important: he says, “The one thing that I like about you, you have what your people call a 'heart'.”

As a child, that's crazy. Everybody's got a heart, right? But he could sense, I can . . . I've always been this way. I care what happens to the other person – myself last. And a lot of times my family don't like that because they think sometimes I put the family last too, which isn't really the case.

But they got to understand, I have to care what happens to other people.

But he went ahead and he told me he'd follow me throughout life.

Now, at that point, I had to make a decision. I could go ahead and fight it, and it would drive me crazy. Or I could accept it and learn from it.

I finally chose the latter at a very, very young age. But I didn't choose the latter until I asked my mom and dad to take me to see a doctor, because the doctor could make the monsters go away.

But once again, they chalked it up just being imaginary friends. So I went ahead and accepted it, and we started to open up a dialogue from a very early age, now, about seven.

At the age of seven, not even a couple months after that, "True" magazine came out with a magazine about UFOs.

And, of course, "True" magazine is considered a men's magazine. Well, I went to – I think the name of the drugstore was Kelso's Drugstore – and I was going to buy a copy of the book. So I went and got the book, took it up to buy it, and I was told, "No, no, no, we can't sell you that. That's a man's magazine."

Then I heard a voice in back of me saying, "Yeah, I'm interested in UFOs too. You're interested in UFOs?" I turned around. There was this person in the Air Force in a captain's uniform. And he went over, got another copy, came on back over, says, "I'll take two copies."

And he says, "So you're interested in UFOs?"

And I said, "Yes, sir."

And he says, "Okay," he says, "Well, let's talk a little." He says, "Have you ever had a strawberry float? Do you like them?"

And I said, "I don't know. I've really never had one."

He says, "Well, we'll get two, and if you don't like it, you don't have to drink it."

So we got two, not strawberry, but root beer floats. We got two root beer floats. We went, we sat down at the booth.

When we sat down at the booth, he says, "Well, tell me, what got you interested in UFOs?"

And he was prodding me, because now he's bringing up things, and I wasn't picking up on it, not with a child's mind.

He knew things that had happened in my life. He knew about the UFO I saw, and that was broad daylight. That was at 10:00 a.m., approximately 10:00 in the morning.

I went to get a friend of mine - his name is **Michael** Eubanks - and we were going to go play ball. I went to the backyard, which was out of the alley, into the backyard, knocked on his door, and started to call out for his name.

All of a sudden I heard this high pitch whirling sound - and bright sunny day, no clouds. It was a clear blue sky. And I looked up, trying to see, because it seemed like the noise was coming from above.

And there was these warehouses in back of . . . on the other side of the alley where his house was. then all of a sudden this white, dish-shaped object came over the warehouses, flew over the open area between the warehouse and his house, and flew directly over his house.

And I remember this day. The outer ring was going clockwise; the inner ring going counterclockwise.

And to me, dare I say, it was like an epiphany, because I saw something I thought I needed to share with the world.

Prior to that time, I didn't believe in UFOs. I didn't believe in flying saucers. I just saw one. And I wanted the world to know that "Hey, these people that are talking about these things? They're not crazy. They really exist."

And I went and told my family, and, of course, my family rejected it. But here it was. Now, I'm talking

to a guy that's a captain, that was listening to me, that was believing what I was saying.

Now, after we finished, he said, "I'm going to give you a copy of the book – the magazine. But first I have to talk to your parents and make sure it's okay with them."

So we went back home, and he talked to my mom. And I don't know what the conversation was because I wasn't permitted to be there.

When my dad got off work – and that was a little after 3:00 because he worked at the Detroit Steel Mill – he came home and they talked to my dad.

And then they went ahead and said, "Okay", cause Captain Brown says, "Well, we're friends now, so I'm going to be coming back to see him from time to time."

And apparently, my family agreed to this. And from that time on, every couple weeks or so, I'd run into Captain Brown. And Captain Brown would want to know if anything new has come up.

And I kept him apprised of the situation. That went on until about March of 1968.

Accordingly, in March of 1968, Captain Brown was killed in a crash of a T33 out of Laughlin Air Force Base.

After that, I went ahead, still had strange things going on from time to time, but they were taking more of a back seat. But by this time, I'm a firm believer.

I know we're not alone in the universe.

Cosmic Disclosure: Close Encounters with Clifford Stone

Season 5, Episode 15

David Wilcock: Hi, there. I'm **David Wilcock**, and you're watching another episode of "**Cosmic Disclosure**" with my co-host, **Corey Goode**.

Hey, **Corey**, how you doing, buddy?

Corey Goode: Doing well. Thank you.

David: All right. Now, we are gonna be talking more about **Clifford** Stone who was recruited by the military because of his empathic abilities and his ability to interface with extraterrestrials.

This guy is totally amazing. I hope you've seen the previous episodes because these UFO crashes don't happen all the time, but they do happen. And he is one of the bonafide insiders who's been out there, I think about 20 years by now, talking about his personal close encounters with crashed extraterrestrial wreckage.

Now let's listen to another one of his fascinating, personal eyewitness accounts.



GETTING ET HOME

Clifford Stone: The next significant event was that they went ahead and they wanted me to go with them to, once again, Fort Belvoir, Virginia.

And I know it was Fort Belvoir because they had one of the entities, one of our “visitors”, that was left behind. And he was being held as a “guest” at this location in a wooded area.

So I went there. And when I got there, he was sitting there, and they had guards all around the place.

And as soon as I went in, he looked up at me. And when he looked up at me, you know, no one else could hear what . . . Just like I say, I can hear it like you and I talking, but I can also feel it.

He said, “I am afraid.” And I could feel the fear, and I could also see, you know, his concern about his seeing his family again.

And I said, “You know, there's no one gonna hurt you.” But, you know, he had that fear.

So I went ahead and I said, “Well, what can I do?”

He says, “My people are coming to get me. And if they come here, they're not gonna try to hurt no one, but because of the technology to extract me from inside this building, many of your kind will die and be injured.”

And I went ahead and said, “What can I do to avoid that? Should I tell them?”

He says, “No, they already know that that is a possibility. The ones that are here that know, know that.”

So I went ahead and said, “Okay, what can I do?”

He says, “Try to help me get outside. So I went ahead and had a friend of mine bring over some wire cutters and place them out by the fenced in area, because the building had a fence around it.

And I went ahead and told the colonel, “Look, he's got to tell me something, but he says he will not do it because there is a little demonstration that goes along with it while any of the military is in here.

“I need the building completely cleared, and it's got to be just him and I.”

Reluctantly, the guy I always called the colonel, he cleared them.

Once again, this alien was – and I can't call it a typical Grey, but the skin was a little lighter than a typical Grey.



The facial features was about the same. The head was not totally round, but, you know, s-long shape is the best way to put it. But he still had a definitive jaw and everything, the large eyes, but it had, like, a yellowish tint to it, if that makes any sense.

But, you know, when he looked up at me, I thought everything he was feeling.

If you missed your child, if you had a person you miss, you gotta understand they missed their family also. It's the same way, but you feel it from their perspective. And it's hard to put into words. But you feel it, then your own emotions come into play.

And at the same time, you know that this little creature is willing to give up its life because it doesn't want to see us be hurt or destroyed because they're coming to get him.

They cleared the place, and I went ahead and told him to follow me, and we started to go out.

Then, as we started to go down the hallway, I started to hear other people yelling, "Halt, halt, halt." And it got to the point where they were saying, "Halt or we will shoot."

So I made him get in front of me. So he's in front of me. And we get out there, and I go ahead and I clip the fence as quickly and as fast as I could.



He goes on out. Then this craft comes over. And as the craft comes over, it was just like this bright light just shining down on the ground.

(4 – extraction)

And like, when it goes off, he's no longer there. He's rescued.

(Emotional) But I can remember I was waiting to die that night because I heard people locking and loading their weapons. And I figured it's only a question of time before they are . . . I'm gonna get shot in the back because they're gonna identify me as being a traitor.

And the colonel was very upset with me. When I called the colonel, he was very upset with me, and he just told me, “The next time, let us know what you're gonna do.”

But I told him, “You know, how do you keep 'guests' under armed guards and call them 'guests'?”

And the whole situation is . . . I will never understand that. He was left behind by his own. We knew of a landing, and we immediately put a “pounce operation” where we immediately went to the area and was gonna try to extract as much of the useful data we could get – even up to and including the craft, if possible.

And I never liked that type of scenario. I never fully understood it because the situation is – were we gonna try to take a craft by force?

And they do have the means to defend themselves, but they don't want to do that. And that was one of the biggest concerns I had was - what happens when we try to do that?

But what happens is we come up on a craft, and the “visitors” already have a rescue ship within the vicinity. Then we go into what's called a holding pattern. We don't approach the ship.

And on several occasions, they took their people and left the craft there intact. So when we got there, we had a craft – the whole craft – but the people wasn't there.

But then again – this is gonna sound crazy – they felt that we were so immature in a galactic sense of

the word, that we could back engineer little bits and pieces of it, but we would never, ever be able to back engineer the whole craft.

Well, I think we have back engineered enough to where we have certain technology where we tell people we can't do things. I have no inside knowledge whether we have bases on the Moon or whether we have bases on Mars and Venus.

But with that being said, I have no inside knowledge that that officially has occurred and that's "officially" happened. I know from the knowledge I have gained, the documentation that's there for anyone to read, the technology has existed all the way to, at least, the mid '50s, and probably long before that.

Let me give you an example.

Take a 2016 car. Take it back to 1776. And I have to use 1776 because there's a little understanding of technology at that time. We will understand how the lights on that car work. We won't be able to back engineer them, but we'll understand how.

We will understand how the fuel works, but yet, we are not going to have the technical capability to process oil out of the ground to make gasoline.

We are going to be able to understand what plastic that's involved there – what it's all about – but we're never gonna be able to replicate it.

So this is where they're coming from.

* * * * *

David Wilcock: All right. Well, as you can tell, this is some pretty intense stuff. And I don't know about you, but I'm not looking at a guy who's lying here. You watch **Clifford** Stone, and there is credibility.

Remember, he had a son who died, and that came out, which, actually, really stopped him from being a whistleblower for a long time.

And the things that he's describing have those kind of really intense, specific details that people who make up stories and are lying just don't have.

So **Corey**, he mentioned that this ET was being held as a “guest”.

Corey: Right.

David: Is that kind of sanitized, big brother-type of lingo fairly common when they're . . .

Corey: Oh, yeah.

David: . . . holding someone prisoner?

Corey: Yeah. If you go somewhere – let's say you're delivering a message – and it's a group that are not friendly with the people you're bringing a message from, it's very often for you to be their “guest” in a room with no door knobs while they figure out how they're gonna respond.

David: Hmm. Now, something that really kind of strikes me almost like the scene in a movie – it's very cinematic – was this being describing to him that there would be some sort of event that would take place that would either hurt or kill many of the people in that base if he were to be extracted with their technology from inside the base.

And then when he did see the extraction, it was some kind of bright beam of white light.

I know it's just speculation, but could you speculate as to what possibly . . . what are some of the technologies that might exist that could cause loss of life if someone was extracted from inside a building like that?

Because, you know, we think of “Star Trek” and like a transport beam, that they can just beam you out from anywhere. And it's the same thing.

Corey: And they CAN do that. I was a little confused about . . . Maybe that being was telling him that as a catalyst to get him moving.

There could be technology that does that, but the technology I had seen and heard about was not gonna cause damage inside of a building that it wouldn't cause outside of a building.

David: Well, here's one thing that I've wondered about. Could it be possible that this particular group of ETs is using some kind of torsion field beam that would basically be like a matter disruptor so that if you're in the field of the beam that, perhaps, the molecular bonds loosen up or something?

And that could cause, potentially, electrical lines to cross over, and then to set on fire larger areas of the building and cause an explosion or something like that.

Are there beam technologies that could lead to those kinds of explosive events, perhaps?

Corey: What you're describing about is . . . There are torsion weapons to do that kind of thing.

David: Right.

Corey: Now, I just can't see how them laying down light to change the being's molecular structure into that of the light and then pulling the light up, I don't see how that necessarily is going to cause a large loss of life.

Maybe some damage to the building, at most. But then again, this could be a technology that this group used that I haven't heard of.

Or it could have been the being using that as a catalyst to get Sergeant Stone to help him escape.

David: Why do you think the being might want to escape instead of just being beamed out from inside the building?

Corey: Well, I don't know. There could be some sort of shielding in the building.

David: Oh.

Corey: Yeah, it depends. If they put certain types of shielding in the building, it disperses a lot of stuff or makes it hard to see who or what's inside.

David: Right. So the being might say that it's gonna hurt people inside to appeal to **Clifford's** emotions.

Corey: And he's obviously . . .

David: He himself might end up going through, like, a meat grinder if it was tried to be beamed out of that field that they've created inside that base.

Corey: Or the beam couldn't reach him at all. They could not be rescued at all, unless they were brought outside of this , , , whatever would buffer it.

David: Are you aware of there being such containment fields at these military bases that would disrupt those kinds of technologies so they wouldn't work inside?

Corey: Yes, but they're usually somewhat like bunkers. I've never heard of a building sitting on top of the ground with barbed wire fence around it shielded in such a manner, but that doesn't mean that they don't exist.

David: Right. So there could be some willful deception going on on behalf of the being just to ensure his safe passage where he did deceive in order to be able to get into the safe transport area.

Corey: That's possible.

David: There was no real loss of life that might have occurred.

Corey: That's a possibility.

David: Right. Okay, now when he's describing the phenology of this being, the description is that it had a paler skin than most Greys. It was whitish, but that he also described that it had a yellowish hue. Now, when we were watching this together and we weren't filing this, you mentioned something about their diet.

Corey: Yeah. The different Greys would . . . Their skin would change color if they were not getting the right diet when they were in captivity.

David: Really?

Corey: I don't know how long. It didn't sound like this being was in captivity that long though.

David: How would the skin change color?

Corey: It becomes paler, paler, and then, almost white.

David: Wow! And do you know what it is that they're missing that we can't give them? What would they eat if they were here?

Corey: It's like us suffering from malnutrition. And I don't know what they eat. I've since read things on the Internet about them absorbing things under their skin.

You know, there were dozens of different types of beings that looked like Greys. So . . . They don't all have the same biology.

David: Okay. Now, I guess the other thing we should cover here is his very interesting statements about taking a car from 2016 back to 1776.

Corey: As long as Benjamin Franklin wasn't there.

David: Ha, ha.

Corey: You know, he probably could have reverse engineered a lot of it.

David: How do you feel about the idea that the ETs didn't think that we'd be able to do very much with their stuff and, therefore, allowed it to come down here?

Corey: Well, by this time, there has already been an ongoing trade with a lot of these different beings, and we had developed technology equal to theirs.

David: But **Clifford's** obviously, not on a need-to-know basis for that kind of intel.

Corey: Right. So, you know, one of the things militarily we do if we have a concept, or a secret helicopter, or craft that we can't extract, we will bomb it - you know, destroy it.

With them not destroying the craft left behind, I'm speculating that they didn't see a need to because we've already developed, on one level, some of this technology.

David: Do you think that these beings might be, again, trying to steer our evolution and deliberately gift us this stuff so that we're gonna get to where we need to be faster?

Corey: It could be. I mean, that definitely occurred, but it would have occurred earlier in history, I believe.

David: Okay. Now, one last thing is that he mentions a “pounce team”. And that term I've seen online in various declassified names of project codes. And I've seen reference to a “Project Pounce”. I'm wondering if you know anything about that.

Corey: Just like you, I remember reading that, that it was a program of mainly, I believe, it was Army mainly, but they'll pull mixed services anytime they can to respond to satellites coming down, secret craft coming down, craft from foreign nations coming down, or unknowns coming down.

David: These pounce teams now have these gigantic, C-5 Galaxy airplanes. And the plane will land at the nearest airfield, and then there's all these . . . They can hold, like, half a million or a million pounds, I guess, of content inside.

Then, all these trucks come blasting out of the plane. And they immediately declare a perimeter around the area. So . . .

Corey: That's a pounce operation.

David: That's a pounce operation.

Corey: Yeah.

David: Okay. So now what we're gonna do is have another really fascinating video for you, this time, of an encounter that **Clifford** had with UFOs and extraterrestrials in Vietnam. This is very fascinating stuff and gives you even more of a glimpse into the world that **Clifford** was brought into.

ALIENS IN VIETNAM

Clifford Stone: Just a couple of months before I went to Vietnam, we had the situation with . . . They told us that they needed us to go to a foreign country because we had an aircraft down and that that craft was a B-52.



They had reason to suspect, which now I know it wouldn't be a reason to suspect. If it had it, they'd know it. But they had reason to expect that there may be nuclear devices on that B-52.

Well, I'm getting ahead of myself there too, because what happened was we were all going to a field training exercise, allegedly. But we were hand-picked. It wasn't the whole unit.

They went ahead and we actually drove down to, I think, it was South Carolina. We went to an air base there. We got on a plane – a commercial airliner. And they were supposed to be flying us in to Florida. And Florida was where we were going to have a training exercise.

So we leave, and, you know, it should have only have been a couple hours flight, not hours upon hours.

But as we got airborne, we flew – six, seven hours passed – I can't remember exactly how much. But then we landed for refueling. You know, you don't need to refuel if you're going from South Carolina, North Carolina, whichever it was, to Florida. You didn't need to do that, but now we're refueling.

Then, we're gonna be taking off again, but they told us, "Okay, once we land, we'll go up to the terminal." We go ahead. We land. We go up to the terminal and they tell us, "No one gets off the plane. We stay right here, and you'll stay on the plane."

So we get up there, and if you know anything about how they refuel, they don't want you on the plane because if there's an accident, you got all those people who's gonna fry. So they don't want that. They want you to get off the plane before they refuel it.

But anyhow, we go ahead, we get up there, and they're refueling the aircraft. And we look out the window. Of course, I'm wondering, "Okay, where's this place?"

And one guy says, "I'll kiss your hind side if this isn't Oakland." Of course, you know, everyone starts to say, "Well, wait a minute. Oakland, that's nowhere . . . that's not anywhere near Florida. What are we talking about here?"

And at that time, the guy we always called the Colonel, went ahead, pulled out a .45 – military issue – all locked and loaded, a round in it, and says, "The next SOB that says a word, I will personally shoot." So he says, "This time, I want you to shut your windows, and I want them to stay shut."

And where there wasn't people sitting, he went ahead and had other personnel there to shut those windows. And he said, "You'll be briefed before we get to our location. And that's all you need to know right now."

And, you know, no one was about to say anything, period. I knew this guy from a couple of other occasions that I was with him, but, you know, I didn't know would he really be willing to shoot somebody or not? But it got as quiet as any . . . You could have heard a pin drop.

The engines were a loud roar when the plane took off, louder than I've ever heard any other jet take off before because it was so silent.

Anyhow, we flew and I don't know – 14, 15 hours, 16 hours. And a couple hours before we landed, that's when they told us, "Okay, we're going into a country in which this B-52 has gone down. The

natives there, the people, the populace, whatever you want to say, they're not friendly towards the U.S. government. We have to get in there, check for survivors and check to see if there is any danger of any bleed off from the radioactive material that's on that craft. And we also have to provide for an extraction.”

So we figured, “Okay, fine.” So when we land, I remember when we were going in for a landing, it's dark. It's night. We looked down. And I remember seeing these fires on the ground - no lights, just fires.

But then, when you get to the airport, naturally, you have the red and blue lights and all that. But as we went in, you know, we were still several thousand miles high, and I thought, this is really strange. This is not Florida. You don't see that kind of thing in Florida.

And I'm going ahead and I'm thinking, “This is crazy.”

But we land, and when we land, they go ahead and let us out. And once we get out, I'm sure some people there knew because there were signs there, and they were in Vietnamese.

Well, I'd never been to Vietnam. I didn't know it was Vietnamese. All I knew is we were in a foreign country. For all I know, it could have been a South American country, whatever. I wasn't putting two and two together yet.

And I didn't see any oriental-looking people there. It was just us.

But they went ahead and took us out of the airplane. There were two choppers waiting for us.

We got in the two choppers, Uh-1s, Huey Slicks, and they flew us. And I don't know how long we flew. It seemed like a couple of hours, but I know for a fact we went to Cambodia.

And I'm pretty sure the area of Cambodia we went to is the Parrot's Beak area.

And there was this little stream that flowed by the area where we were let out at. And that was what we were calling our staging area. So from there, we'd go on into the jungle to where the craft went down.



And you know, of course, you anticipate seeing smoke. You anticipate seeing debris because, naturally, the craft would have had to be blown all to heck.

But when we went in, no one asked for any Geiger counter readings or nothing, but we come up on this clearing. And there in the clearing is this B-52, almost totally intact, except for the damage that was caused to it by natural enemy fire.

And I'll always say I don't know for a fact, because I don't have no inside knowledge, but I still believe it was surface-to-air missiles that hit this aircraft and probably more than one.

The people on the inside had died of the wounds they received as a result of the shrapnel from the hits on the aircraft.

We go ahead. We're looking at this, and I always thought a B-52 was much, much bigger. And don't get me wrong, it wasn't a small craft. It was a big craft, but I always thought it was much bigger.



So I start to walk around it, and I walk around through the tail section. When I get around to the tail section, I go around to the other side, and I hear this, like something in the bush.

So I turn around, grab ahold of my M16. I don't bring it up yet, but I grab ahold of it. Then I look and this – a typical Grey – and once again, I would have to say about 3, 3-½ foot tall, comes out. Then several others come out with him.

Then I remember to this day what was said. And it said, “**Clifford**, what are you doing here? You are not supposed to be here.”

And I remember I still think I may have been the first to fire. I don't know. But I brought up my M16, fired, and started to yell, “VC”.

And you know when you get real humble? When you know you're hitting something with rounds from that M16, and it's having no affect. You get real humble because the whole situation is you now realize any other weapon you have on you is useless. And you are now at the mercy of whatever it is you were just trying to shoot.

So the whole situation is that we started to fall back. By this time, other people were shooting.

Like I said, I may have been the first one to fire. And why did I even say, “VC, VC”? They didn't tell us we were in Vietnam. They didn't tell us anything.

Only thing is, you know, there was mention made of the “little people”. I knew what the “little people” meant.

But as we pulled back, we got all the way back to the river crossing. And they followed us to a short distance. But most of the people stopped shooting because, I think, within all of our minds, we were all like . . . we realized shooting is no good. It's not going to hurt them. And they're not really trying to do anything to us yet.

And the question is, if they have weapons, they might try to use their weapons.

We got across that little crossing. And when we got back there, immediately we were told, well, those

were the local natives we saw there.

We were thinking, what kind of scam are these guys trying to pull? These entities, no, no, no. They're not people. They're not local natives. And I already knew from other experiences.

But when we get back there, the guy that I always called the colonel says, "I need a volunteer, because we have to go back there."

And I'm looking around. And the other people are like, "Well, I'm not going." "I'm not going."

And I darn sure didn't want to go. But the, I kept thinking and thinking. And I went ahead and got my M16. Without saying anything, I started to go back across the stream again.

Prior to that, the guy that I always called the colonel, he asked me. He says, "Are you afraid?"

And I said, "I'm human. Yes, I'm afraid." But then I grabbed my M16 and started to go back because nobody was about to vol . . . nobody wanted to go back there because we didn't know what we were going in for.

And I went ahead because I had experiences in the past. Started crossing and the colonel said, "I thought you said you were afraid."

I turned around, "Yes, sir. I'm afraid, but I got to know what's going on. I got to go back there. I got to see what's going on there. None of this is making any sense."

So I started going. One by one, the other soldiers that were there with me grabbed their M16, and they followed suit. They followed me.

We got back there. When we got back, we extracted the bodies. We called in to have them lifted out. Then we were told that there was an engineer team coming in. That they would be going ahead, and I think they called it "piecing". I may be calling it wrong. But "piecing" because they were gonna cut the aircraft up.

They cut it into five portions. They cut the wings off. They cut the tail section off. And then they had the fuselage. Then they had what we call CH54s. Flying cranes is what they called them.



They came in, and they picked up piece by piece.

Then we went back to the area that we called the staging area. The helicopters came in, picked us up and flew us back. We got back on the aircraft that we came in on, and we left, and we came back to the United States.

* * * * *

David: Corey, let's start with something simple first before we get into the tough stuff. And that is, some people who are skeptically inclined might say, "Come on. The colonel is gonna frickin' shoot somebody's brains out because he questions whether they're flying to Florida when he says it looks like Oakland, California?"

Is it true that the military would consider an operation to be so secret that you're flying somewhere, and if you even try to figure out where you're going that they will blow your brains out?

Corey: Yeah. Yeah, they do that to soldiers. They do it to civilian contractors. That's . . . I mean, that's SOP.

David: So why would they not want these guys to know where they're going?

Corey: Going back to “loose lips sink ships”. And if they don't know information, they can't reveal information. It's part of the compartmentalization.

David: So if he said that he's part of this Project Pounce”, then keeping it compartmentalized means that he doesn't have any information that he could leak to any enemies of the United States if he got captured or tortured or something? Is that part of the idea?

Corey: Or decided to go to the media.

David: Right. Okay, so he ends up in Vietnam, and this is in the theater of war in 1968. Now, this is where the thing gets really, really bizarre.

He's going around what appears to be a crashed craft of American manufacture during an active war, in the theater of war, in Vietnam. He goes around the corner, and he sees a group of Greys.

And then the Greys tell him . . . They call him by name, and they say that he's not supposed to be there. What the heck is going on here, dude?

Corey: It could be several things, like they were in the middle of an operation. “What are you doing here? You shouldn't be here.”

But the feeling I got was, “Wait a minute, aren't you supposed to be in Georgia” or wherever he was? “How are you thousands of miles,” you know? “What are you doing here?” you know. “You're not supposed to be here. This isn't your theater of operation. You're stateside.”

David: I guess I'm not really getting to the core of this, which is what the heck are these Greys doing in an American War? Why would they care? Why would they be right near a ship that has just crashed with all these dead people inside?

Corey: Well, this is a phenomenon that's gone on in just about every war and skirmish.

David: Really?

Corey: Yeah. The nonterrestrials that have human beings that they consider assets, they will often protect them. Or if something happens related to them, go and investigate.

David: So you're saying then that, perhaps, some of the people on the B-52 were high-level assets that these Greys considered vital for them, as well as for America?

Corey: I'm speculating. But there could also . . . A B-52 can carry some interesting things with a few modifications.

David: Okay.

Corey: So they may have had something else inside that B-52.

David: So in other words, there could have been some extraterrestrial material or technology that was on that ship, and it appears to have been shot down by enemy fire.

Corey: That's a possibility.

David: I want to get right to the core of another key question, which is, to your knowledge, has there been direct collusion between entities like the United States and extraterrestrials like Greys to fight a war together like Vietnam?

Corey: Well, yes. They don't fight the war with us, but they have agreements with different nonterrestrials on what kind of a role they will play observationally or any other number of possibilities.

They have agreements with certain nonterrestrials before they go to war, during war, but they're not normally fighting with them in the war.

David: Now, we've heard that both Truman and Eisenhower signed these treaties with Greys, including the Tau 9 Treaty, which apparently was about abductions.

Is it possible that part of what these treaties with the Greys would include is that if the U.S. government

allowed them to abduct a certain amount of American citizens that in exchange for that, that they might give certain things like logistical support for war efforts?

Corey: Well, at that time, we really didn't need their logistical support because we had a lot of this technology developed on our own, even in the late '60s.

David: What technology?

Corey: Technologies for observing the enemy, you know, a higher level of tactical support abilities.

David: So if the treaty has been signed, why do you think these ETs would care at all about what's happening to us in a war? I'm still trying to get to the core of what might be going on there.

Corey: Well, I don't think we're ever gonna know what was going on there. All we're gonna do is be able to throw out a lot of speculation. There's any number of reasons why they were on scene there.

The reasons I just described to you are just a few.

David: Okay. Another thing that I think everybody's gonna want your take on before we end this episode is, how do you shoot at beings with M16s and not hit them? What the heck was going on there? They didn't seem to have the slightest concern about those weapons.

Corey: The common era weapons that we have, or the era of weapons that we have, kinetic weapons, even high-energy weapons, they have defenses against.

David: Now you also mentioned that Project Pounce also takes care of Broken Arrow.

Corey: Right.

David: Would you explain for our viewers what that is?

Corey: Well, a Broken Arrow situation is when a nuclear weapon has either crashed or we've lost it in some sort of an incident. A Broken Arrow means a nuclear weapon or device that is no longer in our possession.

David: Wow!

Corey: That's right up there – the highest thing, the quickest thing, that they'll respond to, as well. If they . . . If these Special Access groups are told we have a Broken Arrow situation, they are in the plane, and they are out there immediately.

And you have the veil of secrecy that comes along with that situation.

David: All right. Well, thank you, **Corey**. And I thank you for watching. This is really fascinating stuff.

And we are bringing you the cutting edge of “[Cosmic Disclosure](#)” here on Gaia. Thanks, again, for watching, and we'll see you next time.

Cosmic Disclosure: On the Other Side of the Veil of Secrecy

Season 5, Episode 16 [Editing note: there were many pictures for this episode, but none were on the available archives]

David Wilcock: All right, welcome to “[Cosmic Disclosure](#)”. I'm your host, **David Wilcock**. And in this episode, I am here with **Corey Goode**, and I'm also here with Dr. **Bob Wood**.

And Dr. **Bob Wood** is going to be our focus. Part of the reason why is that he has been acquainted with **William Tompkins** since 2009 and knows a great deal about **Tompkins'** testimony. In fact, he's practically a walking encyclopedia of what **Tompkins** knows.

But, **Bob**, you also are coming into this with a lifetime of very bizarre, interesting experiences related to this whole topic of [cosmic disclosure](#). So I just want to hand it over to you now.

And I know you said that you have some very critical autobiographical information you want to give us about yourself that will become very relevant as we go forward in your story in the timelines of what's happened to you.

Dr. **Bob Wood:** Yes. It started, actually, in 1949 at the University of Colorado when I graduated.

And after then, I got a job at Douglas Aircraft Company for the summer because my father was a professor, and he was always talking with the guys who were hiring engineers

So he just . . .

David: Douglas is the same company that **William Tompkins** worked for.

Wood: Exactly. It was . . .

David: Right.

Wood: Douglas, at that time, had merged to McDonnell-Douglas in 1968.

David: Right.

Wood: So my first summer job was working on missiles that day. I worked for some of the same people that later turned out Bill **Tompkins** was working for.

David: That's wild.

Wood: It is wild. But actually . . .

David: Could you give us a couple of names?

Wood: Yeah. Dr. Klemperer was one of them. Wolfgang Klemperer.

David: Klemperer, right. He calls him 'Klemp' in the book sometimes.

Wood: That's right. Yeah. And the other one was Elmer Wheaton.

Elmer Wheaton later became a vice president of Douglas until he got hired by Lockheed.

So after one summer job, I went to start to get my PhD, and I got my . . . I had a break, and I took another summer job and worked for some of the same guys.

But it was interesting that at that time, I looked around to see if there were any vaults [secret think tanks] or secret things going on, and I was told there weren't any, and I didn't ever notice any.

But it turned out that towards the end of that summer, at that same time, if I had been paying attention, I could have seen Bill **Tompkins** walking down the aisle.

David: No kidding.

Wood: Yeah.

David: Ha, ha, ha. Very interesting.

Wood: So from there I went on and got my PhD, and then I went to work for Douglas until they drafted me. I went to work for the Aberdeen Proving Ground for a couple of years and worked on ballistic . . . well, shell dynamics. It was a good experience.

With that behind me then, I was asked to select an area, and so I selected thermodynamics, because they were really starting to build – actually, it was the Air Force, the M-18 that Bill **Tompkins** worked on.

It was a Thor missile at the time, . . .

David: Right.

Wood: . . . and they worried about whether the back of this Thor missile would get hot, and so that was one of the challenges. Actually, I spent most of my time early on working on the Nike-Zeus missile.

And I actually hired Jerry Buss, of known fame now, who was a chemist, to decide how much Teflon we should put on the leading edges of the fins on this missile to keep it cool.

Well, anyway, my career went on, and I got involved in aerospace management. We managed the independent research and development program. And I got involved in the Space Station design later on.

And by 1993, I retired.

But in 1968, there was an unusual event that happened that caused me to become involved in UFOs.

David: Okay.

Wood: It was pretty simple. My boss said, “Hey, I’ve got to give a briefing to the Air Force next week. And they want to know, 10 years from now, how we would go to orbit and back.”

And I said, “Well . . . “ - just for a joke – I said, “Well, Ray, why don't we tell them how many alleged UFOs would do it.” And he said, “That's a great idea. Why don't you work on that?”

So I read my first UFO book, and it was by Don Menzel. And he wrote the . . .

Corey Goode: In 1968?

Wood: 1968.

Corey: Wow!

Wood: I read my first UFO book. And I kind of concluded, “I don't care if this guy is a famous astronomer, he's obviously ignoring the data.” So I read more books, and the briefing went off okay.

But a year later, my boss was out of town, and his bosses had me give the usual report on how we were doing on contracts and that sort of thing. And at the end of this meeting, he said, “By the way, Dr.

Wood, we don't often see you. Tell us what you're doing that's interesting.”

And I said, “Well, you're not going to believe this, but I've read 50 UFO books in the last year, and I have concluded that everything is certain. That is, we know that there's aliens coming here in spacecraft. The only thing that's not sure is whether we figure out how they work before or after our Lockheed competitor.”

And there was a moment of silence, and my boss said, “What do you think it would take to look into that?”

So for the next year and a half, actually, they gave us a half a million dollars. I hired Stan Friedman, who's now a well-known UFO guy, to read the literature and see whether or not there was something in the literature that would tell us how they work.

We had a laboratory. We did laboratory tests. We hired a detective to interview abductees and stuff like that, which, in those days, was kind of outside the norm.

David: So what were you thinking, **Bob**, when you're seeing, obviously, all this data? You're obviously a credible, credentialed PhD. You're looking into this data scientifically. You have a half million dollar budget in 1968 dollars.

And then you're looking at the public and how the media is presenting this as if it's a big farce, and it's a joke. And, "Oh, it's all swamp gas!" What did you feel about that at that time?

Wood: Well, that's when the swamp gas report first came out, is actually that era.

David: Right.

Wood: It turns out that I was focused on learning something, and so I joined organizations I thought were relevant – MUFON and CUFOS. And I would up meeting James McDonald.

And so whenever he came to town, I would go to his lectures, and I became pretty aware of the work that he did.

He was the one who said, "You ought to go visit the Condon Committee and tell them what you think."

David: Wow!

Wood: So I did. I went to the Condon Committee.

Corey: Wow!

David: Ha, ha, ha.

Wood: And I said, "Well, . . .", I told Condon and his committee, I said, "Do you know we're doing a little study? And we did come up with one way that you could build a UFO that would potentially work. You could hover in the Earth's magnetic field."

So I went through designs. And it turned out, it doesn't work, because it's not practical.

But at the end of this visit, I decided that I would write Professor Condon a memo, a note, which I had properly approved. And I had suggested to him that maybe he could divide his team up into two parts: part of the believers and the nonbelievers, the skeptics.

And he got this letter. I also, in this letter, decided that I would send a copy to everybody on his committee.

David: Ha, ha, ha.

Wood: Ha, ha, ha. Well, he was so upset that he called up James S. McDonald on the phone and tried to get me fired.

David: Really?

Wood: Yeah. And I had no knowledge of this until months later, when my vice presidential boss said that he had to deal with that.

And fundamentally, James McDonald didn't like some university professor telling him how to run his business. And I had performed all the required approval signatures before this letter went out.

David: Could you just . . . For the viewer . . . I'm sure we're going to get comments if I don't say this. Explain to people who James McDonald is?

Wood: James McDonald was one of the scientists and atmospheric physicists, actually, who really dug into the individual cases, especially those that involved radar lighting up – all the physical cases. And he put them together so effectively that he testified to Congress that there were clearly . . . that there were objects there.

David: Right.

Wood: So Jim McDonald and I became good friends and colleagues, and I was dismayed to find out that he'd committed suicide a couple years later. I could never imagine that happening.

But, actually, I did . . . it was . . .

David: Do you think it was suicide or not? I mean, a lot of times these guys commit “suicide”.

Wood: I have now concluded, with all the apparently classified work that the CIA has done on influencing people and psychotic drugs and stuff like that, anything's possible.

David: Yeah.

Wood: But the one thing that told me that McDonald was really interesting is . . . I knew him well enough that once I was going through Tucson on business, and I stopped off, and he was willing to meet me at the airport. So we had been looking at the evidence, and he said, “**Bob**, I think I figured . . . I finally out how it's working.”

And in hindsight, I have concluded what he had found . . . he had found one of the top secret documents that said that we had really recovered lots of craft.

David: Hm-mm.

Wood: And in those days, that would have been a huge revelation. But he didn't tell me that. He just said, "I finally found out what's really going on." And that was the last I knew. And the next thing I knew, he was dead.

Corey: Yeah, that sounds suspicious.

David: Well, it's really fascinating just to have you here and to be getting a window into this history of Project Blue Book and the whole very obvious government cover-up that was put in place.

And for you to have been given the same budget money as the Condon Report, but yet your findings obviously were not put on the same level in the media as the whitewash.

Wood: Well, actually, the reason for that was McDonald was . . . He was really a pretty pressure guy. He said, "Dr. **Wood**, because of all the work you're doing, you ought to testify to Congress."

David: Right.

Wood: So he set it up so I could be on a congressional committee. I got an invitation from them, actually. So I consulted my management, and I said, "Look," I said, "You guys are treating me pretty well. I'm a Deputy Director and going on to a pretty good career, it seems like. And I've got this opportunity to testify before Congress."

And one of the VPs, who was kind of my friend, he said, "Well," he said, "I don't ever remember knowing anybody who had a lot of good from coming to testify to Congress." Ha, ha, ha.

David: Ha, ha, ha.

Wood: So I thought about it a lot, and I decided, no, I wouldn't do it. And, furthermore, right about that same time, we lost the MOL program. And we just got an opportunity to bid on a ballistic missile program – defense program. And they didn't have any radar guys.

And furthermore, on this project, we knew how fast we were spending money on these four or five different aspects, but we didn't know how close we were getting to any answer.

So we all agreed, "Let's kill it." So we stopped it in 1970.

Corey: 1970.

Wood: And I made a deal with Stan Friedman that he would never talk about this. And we were going to write it up to tell the government what we'd done, and it turned out that our management decided, "No, we'll pay for it right out of profits. We don't tell the government we're doing this subject."

Then I became a radar expert for ballistic missile defense for the next 10 years. And that turned out to be interesting too because it gave me top secret clearance for stuff, and the CIA was a customer to study the Soviet ballistic missile defense program.

And my career went on until I got assigned to the Space Station. So for the next 10 years, I worked on the Space Station, which is a lot of fun, you know. It's up there now.

Corey: Yeah.

David: So you're talking about the International Space Station, the ISS?

Wood: Yeah. Yes. Yeah.

David: What was your role in the ISS's development?

Wood: My role there was to try to make the Space Station cheaper, better, sooner or safer by using advanced technology. It turns out that really, it was a low-tech thing, and we made it out of aluminum, for heaven's sakes, you know.

Corey: Hm-mm.

Wood: It's the cheapest. So the question was, could we take any of this high, sophisticated stuff that I'd been managing, and get some benefit out of it by putting it on the Space Station?

However, my career was sort of very conventional . . .

David: Right. Right.

Wood: . . . except for this one little tweak there where I was working on the UFO program.

David: Sure.

Wood: And then when I retired . . . However, in the process of knowing about some classified material, I was working with a guy in a vault who was interested in some psychic stuff. So he introduced me to Russell Targ and Harold "Hal" Puthoff over at Stanford.

David: Oh, yeah.

And so we took a visit up to Stanford, and I got exposed to remote viewing and . . .

Corey: At Stanford Research, when they were actually . . .

Wood: Yeah, right.

Corey: . . . doing that work?

Wood: Yeah, when they were doing that work.

Corey: Wow!

Wood: That was the '80s. And, in fact, my enthusiastic guy in the vault said, "Well, why don't we turn in a proposal to James McDonald and try to do a coordinate remote viewing job, experiment?" So we did.

In remote viewing, a target is selected, a person is selected, and at the right time, the person is asked to describe the target, which they've never seen.

David: What would the target be, for example?

Wood: It could be a ship sinking in the ocean.

David: Okay.

Corey: Or a new type of radar on a ship that we haven't got a good look at.

Wood: Yeah.

David: Okay.

Wood: However, in this particular case, one of the things that had never been done in that time was to just use the coordinates. And they would take the coordinates of latitude and longitude, and those are the coordinates that are on a piece of paper. And the remote viewer is asked to describe what those coordinates . . . what's at those coordinates.

David: So this is an intuitive, psychic thing they're doing.

Wood: Yeah. Right, right. So we did that. Actually, it turned out that James S. McDonald, without taking the proper advice of his lawyers, he gave us \$25,000 to do that.

Then later on, they found out what he does. "Never do that again!"

David: Ha, ha, ha.

Wood: Well, that was just a minor portion of everything I did. What happened, however, was that I met Hal Puthoff, who exposed me to the fact that there were people who were thinking about things psychically. And I became active in the SSE – Society for Scientific Exploration – a group of university professors, typically, who were willing to think outside the box.

In any case, I retired in 1993, having had what I thought was a fun, successful, career, beginning with the missiles and ending with the Space Station, and having lots of fun on classified work in between.

David: Yeah.

Wood: I couldn't have had a better career. So then, in about 1995, my former long-time friend, Stan Friedman, who had been my first employee, called me up and said, "Hey, I've got a fax that looks like it's a classified document. I got it from a guy by the name of Don Berliner, who works in this area.

He said, "It's sort of a fax. It's called 'Extraterrestrial Entities and Technology, Recovery and Disposal'. Would you like to try to authenticate it?"

David: Wow!

Wood: And I said, "Why, sure. I'm not doing anything." Ha, ha. So I went and I visited and got the high-quality copies of this document, which was a Special Operations Manual, 1-01, and replicated it in

great detail and went and talked to a guy at the printing office and showed him the document.

And he read it. It was stamped “Top Secret”, which was a little bit awkward, but . . .

David: Right.

Corey: Yeah. Approach him, “Oh, by the way, I have a top-secret document in my hand.” That doesn't go over very well. I'm surprised he touched it.

Wood: He read it. And then he put it down, and he said, “You know,” he said, “based on the content, I'd say it's clearly . . . It's a hoax.”

Corey: Ah.

Wood: But . . .

David: Based on the “content”.

Wood: Yeah. Based on the . . . However, he said, “If I look at the details of the font that was used in that area, furthermore,” he said, “the tail of the F and the G are specifically relevant to that. In addition,” he said, “I found that there are three raised Zs in this document.”

And I said, “Well, what's that about?”

And he said, “Well, what happens is when you have a hot lead printing press, it turns out that a rarely used letter, like the z, gets some crud underneath it and doesn't properly seat. And so you can read a document, once in a while, you find that those Zs are slightly raised off of the base.”

And he said, “I found three Zs in this document that were raised. Therefore, I know that it was printed on a hot lead printing press, and it would have had to have been in that era of 1954.”

So he said, “This was clearly printed on one of our printing presses, either in the basement of the Pentagon or right in this building here.”

Corey: Yeah, because he would be familiar enough to know the typeset, where things were placed on the page, how the dates are arranged, everything.

Wood: Right. So anyway, my son, who had met Stanton Friedman when he was 15 years old, got interested in this stuff, and he and I became partners.

So we gave a speech at one of the UFO meetings in Connecticut. And at that meeting, they responded by saying, "Wow! This is the first time we've seen anything that seems to be analytically evaluated and has an authenticity aspect that is pretty good."

So I declared that I was going to become an . . . authenticating documents, but in the meantime, another person came out of the woodwork that Stan Friedman had heard from, Timothy Cooper, who lived in Big Bear Lake.

David: Oh, yeah.

Wood: And nobody had ever gone to see Timothy Cooper. So Stan asked me if I'd go see him because I lived closer than he did in Canada.

I said, "Sure".

So I went to see Timothy Cooper, and Timothy . . . he said he was delighted to have somebody actually pay attention to the fact that he had some leaked classified documents. And he went over the background with them and all that.

Well, that's kind of a long story, but, in effect, it put me in . . . well-known in the business of being a document authenticator. So I've been able to establish that kind of as my expertise area.

And along the way, I got asked by Joe Firmage to make a . . . well, actually, to authenticate his documents, and to . . .

David: Really?

Wood: Yeah.

David: So for those who don't know, Joe Firmage is this guy who had a very large amount of money who popped up for a while in the late 1990s and wanted to finance UFO investigations.

Wood: That's correct.

David: Right. So you actually worked for him?

Wood: Well, I don't want to say anything on this show that would be inappropriate, but I think that what actually happened is perfectly okay. What happened was that Joe Firmage had heard the word that I had some of these documents that I was trying to authenticate.

So he called me up out of the blue, and he said, "Hi. I'm Joe Firmage." He said, "I've got a yacht in Newport Beach. You live in Newport Beach." He said, "Could I . . . if I could authenticate those documents, would you be interested in lending them to me?"

And I said, "Well, let me think about that." And I called up . . . And he said, "Well," he said, "if you want to check me out, you can check Harold Puthoff. He knows me." So I hung up with Joe and then called up Hal, and said, "Who is this guy?"

And he said, "Well, he's a good guy."

David: Yeah.

Wood: And . . .

Corey: He's not going to steal the documents, right?

Wood: That's right.

Corey: That's what happens a lot.

Wood: So in the meantime, in this conversation, Joe had asked me, "Well, what do you think they're worth?"

And I said, "I don't know. They might be worth millions."

So anyway, I went, had the meeting. My wife, in the meantime, had wondered why I'd been wasting all my time since I retired studying UFOs. So I went down to this meeting, and Joe looked the documents over.

He said, “This is exactly what I want, Dr. **Wood**. What I'd like to do is I'd like to borrow these, have them authenticated, and if they're authentic, I'll print 2,000 copies of them for you under your specifications, and you can have them all back.”

And so I said, “Well, Joe, is that . . . that's your proposition?”

He said, “Oh, no. I forgot something.” He opened up his briefcase and took out a check for \$500,000 already made out to me.

David: Oh, my gosh.

Wood: So I got on the phone with my son, and we couldn't figure out any reason to not accept the offer.

Corey: Yeah, that's kind of a hard thing to turn down. Yeah, no strings attached.

David: Ha, ha, ha.

Wood: I ran home and showed my wife this check. She said, “How'd the meeting go?”

I said, “Well, here is the answer.”

And she said, “How do you know it's any good?”

So . . .

Corey: She didn't mind you looking at UFOs after that.

Wood: That's right. Exactly right, yeah.

David: Ha, ha.

Wood: So we checked it out. Turns out, it was in the same bank I banked with. And then Monday morning, I went. It was good. Called up Joe and said, “Joe, do you want to go ahead with this deal?”

And he said, “Yes.” He said, “I want you to do that. Cash the check.”

David: Wow!

Wood: So that turned out to be very effective. Joe did everything he said he would do. He got it all printed, helped . . . assigned his company to help work with my son and me for that.

And then he liked the whole idea so much - of the secrecy, of the country, and so forth - that he wanted to do a television documentary called “The Secret”, where we took the essential ingredients of our authenticity procedures and tried to share them on this television documentary.

David: Just to be clear, this is not the movie, “The Secret” that says that you can ask the universe for as much money as you want, and the universe gives you the money?

Wood: It's a different movie. It's called . . .

Corey: And a different secret. Ha, ha.

David: Ha, ha.

Wood: The full title of the movie is “The Secret: Evidence We Are Not Alone.”

David: Okay. So how are you familiar with **Corey Goode's** work? Let's just divert a little bit into that. Have you heard about it online, or how did you find out about what he was saying?

Wood: Well, actually, I hadn't heard of **Corey Goode** until a year ago.

David: Okay.

Corey: Yeah.

Wood: And the reason for that was because I . . . and this relates, actually, to Bill **Tompkins**. I met Bill **Tompkins** in 2009. He said he'd been trying to write his autobiography for nearly a decade.

He'd tried with several various editors and writers, and they were never able to squeeze anything out that was like a book. And he was wondering whether I'd be willing to try it.

So we began to become acquainted, and I went through the process of actually taking the words that Bill started with and turning them into a book.

David: Hmm.

Wood: And that's not a trivial process. Ha, ha.

David: Sure!

Wood: But as the book, “Selected by Extraterrestrials”, got published, it turned out that **Michael** Salla, who is a well-known researcher and author, had just published a book about the Secret Space Program. And he said he wanted to interview Bill **Tompkins**, would I help him do that?

So I decided that I want to know something about Salla before I did that. Even though I'd known him some years before, I hadn't read his recent work. So I bought his book, “The Secret Space Program”.

And that's where your name, I think, first . . . I first saw . . .

Corey: It first popped up for you.

Wood: Yeah. So I read this book. I said, “Wow! There's more to this than I thought.” I never imagined there might have been a Secret Space Program.

And then as I started to think about what Bill had been showing me, namely images that he had drawn in 1954 of one kilometer long spacecraft that it might have been the beginnings of a Navy program that could have become something like Solar Warden, which is presumably one of potentially several space programs that may indeed be in existence.

So it's just in the last year that my mind has suddenly been able to grasp the idea that we might really have had these Secret Space Programs.

If fact, if there's any one thing I've learned now that I didn't know five years ago, it's the incredible level of secrecy in this government for this and other subjects.

It's absolutely incredible that people would . . . I mean, if you tried to tell somebody that the Nazis had a space base on the far side of the Moon in '45, they'll look at you as if you're from some other world.

David: Ha, ha, ha.

Wood: So I have tried this technique. If I can convince you that the Nazis had a space base on the Moon in 1945, would you believe everything else I'm going to tell you? Ha, ha, ha.

David: Ha, ha, ha. So **Corey, Bob** walked in today with a piece of paper printed out, high resolution, of a diagram that **Tompkins** made of one of these craft that he was working on.

Corey: One of the cigar-shaped ones.

David: Cigar-shaped, modular. Lots of little blocks that all are built to be able to fit together and build one of these. What was your feeling when you saw that?

Corey: Well, actually, I had . . . before I had seen it, I had worked with an artist to depict one of these craft, and they were very similar.

Wood: Really?

Corey: Very similar. And they were, indeed, very modular. Everything was . . . The whole middle of the craft was . . . The walls could come in real close or it could be pushed way back, and they could build modular rooms to do research in them.

So a lot of what he designed came about.

Wood: Well, one of the things that excites me is the fact that the things that he . . . everything he says he did, what I've been able to confirm, it was exactly correct. All the people that he said he knew, I knew those same people.

Corey: And his documentation is just unbelievable.

Wood: Right.

Corey: It's crazy. I wouldn't say 'unbelievable', I mean, it's completely believable. I mean, it's . . . and you verified it.

Wood: But the fact that he was, for example, working in this think tank – that's what he called it, a think tank, instead of a 'vault' – and in this think tank with Lemperer and Wheaton, every so often, they would get a phone call from the Navy.

Well, one of the people who he said occasionally called him was Bobby Ray Inman.

David: Wow!

Wood: And I checked to find out how old he would have been, and he would have been just starting up in his career, maybe as a lieutenant or something like that. And he was the guy who was telling **Tompkins'** group what to do next.

So you put that together with the fact that this kilometer-long craft kind of resembles what the Navy might have build later, would seem to be consistent with the Navy having been involved in that process.

The wide variety of things that **Tompkins** worked on at TRW is pretty exciting to me. And he said that they had a green light to look on anything that was interesting in the whole world.

You know, how were the pyramids really built? How do you keep somebody living forever or as long as the pharaohs used to live? How do you do that?

And there was nothing that was off limits. How do UFOs work?

And, of course, one of the things that most people are surprised at is that Bill's . . . his direct testimony, the fact that the RAND Corporation was specifically formed by Douglas in order to study the alien problem.

David: Oh, wow!

Corey: Yeah, that's pretty big.

Wood: Yeah. But . . . well, my comments on RAND would be that I think they have modified a great deal from their original purpose. I think when they started, they hired two groups. They decided to have a group of people who were given the real data that the Navy had presumably recovered from the 19-- . . . the Battle of LA crash.

And then they had another group of people who were skeptical scientists, who would be willing to ask the question of what would it take to have intelligent life? Is it . . . How would you do that?

And it turned out that my uncle, that is from my first wife, was an employee of RAND in the second category. And he and I had many firsthand conversations, and he was the classic skeptical physicist. He tried to prove to me that you can't travel faster than the speed of light. Nothing will happen.

But now, Bill **Tompkins** is saying that there was another part of RAND that was studying the real data. And he didn't know anything more about what RAND was doing though. All he knew is what he was doing in the vault. And what he was doing in the vault was based on what he was being told.

I don't think he ever claims to have seen any recovered parts.

David: I'm curious about the timing of **Tompkins** coming forward. I mean, yes, you say he was working on his book for 10 years. But we have **Corey**, who was given briefings, saying that multiple insiders were going to come forward who would be able to corroborate what he said.

And I'm really curious about your thoughts on . . . I mean, you say that there was no direct involvement in the writing of **Tompkins'** book with intelligence services or anything like that. But as far as you know, you're authorized to say whatever you want to say? You're cleared to come forward like this?

Wood: Me? Yeah. Yeah, I'm cleared to say anything I want to say.

David: Okay.

Wood: And the only risk I worry about is I don't want to say anything that would cause a libel suit or anything like that.

David: Sure.

Wood: But other than that, we're perfectly . . .

Corey: And I'm sure there's other classified things you worked on that are . . . don't pertain to this that you can't talk about.

Wood: Well, actually, the only classified thing that I worked on was really not very exciting. You know, since we were experts in ballistic missile defense, this group I managed was experts in the Soviet ballistic missile defense, and that's what I studied, is how did the Soviets defend against our missiles.

Well, it's no big deal. You'd expect there to be . . . them to have a program like that. I mean, it would be classified with the details of how they did it and the fact that actually, some of their ideas were better than ours. That would be classified. Ha, ha, ha.

David: Well, we also had a conversation, and I might be throwing you in a little bit by saying this, but . . . where **Tompkins** told me that he's still on the inside.

Wood: I'm a little mystified about why Bill won't tell me 100% of everything. He does show that he is still . . . appears to be invited to the annual West Conference that the Navy has, with the clearances that get him into rooms he shouldn't be into.

And, in fact, that happened just this year. Someone has determined that even at his age, he's perfectly willing to be told about things that nobody knows about. He went through . . . into one room where he saw information on Solar Warden.

David: Really?

Wood: Yeah.

David: At one of these classified meetings?

Wood: The last one.

David: Really?

Wood: Yeah.

David: Wow!

Wood: There was nobody there but contractors. So . . .

David: Are you aware that **Corey** worked in Solar Warden?

Wood: Well, yeah. I assumed that.

Corey: Right.

Wood: Yeah.

Corey: That was the '80s project.

Wood: But did you, **Corey**, go to deal with contractors in the program?

Corey: No. There were civilians. There were civilian . . . what they called 'eggheads', scientists and engineers and that type of thing.

Wood: Yeah.

Corey: But there was never discussion of who they worked for corporation-wise, if they did work for a corporation, or if they were just recruited.

Wood: I see.

Corey: So I don't know if any of those people worked at any of these defense . . .

Wood: But the assignment you had would not have given you, normally, much information about the management structure.

Corey: Right. Right. You really didn't learn a whole lot about anything a tier ahead – above you. And you would learn a little bit about some of the people you were working with, but information didn't flow real freely when it . . . on command structure.

Wood: Yeah.

David: If **Tompkins** is still having these meetings, and he still has his clearance, and you seem to believe that's true . . .

Wood: Yeah, I don't think he's being told anything very specific on a regular basis. He claims that he was told by Webster to tell it all. I think that's on the back cover of the book.

David: Ah. And who's Webster, now?

Wood: He's an admiral that he knew personally, I think, when he lived in Oregon, perhaps.

David: Okay.

Wood: A retired admiral.

David: Okay.

Wood: And he said, “Tell it all!” And so that's why Bill feels comfortable in telling it all.

David: I want to ask you just a really brief opinion question, and that is what was it like for you to encounter **Corey's** testimony and see so many astonishing crossovers to what you had been gathering from **Tompkins** in the preceding seven years? What was that like for you?

Wood: I've concluded that your involvement could conceivably have been the ultimate result of what **Tompkins** might have started. But my feeling is that **Tompkins** didn't have any way of following that in detail.

I really don't think that he . . . and I talked to him today, actually. I didn't ask him this question. But I don't think that he had any knowledge of a Navy space program while it was being developed at all.

David: All right. Well, this is all the time we have for in this episode of “[Cosmic Disclosure](#)”. I hope you've enjoyed it. This is a really valuable window into the history of UFOlogy.

And here we have somebody who was right on the front lines of this fight for Full Disclosure, which I do believe we are going to get, and this show is part of that process.

I'm [David Wilcock](#), here with Dr. **Bob Wood** and **Corey Goode**, and I thank you for watching.

[Cosmic Disclosure: Validating the History of the Secret Space Program](#)

Season 5, Episode 17

David Wilcock: All right, welcome to “[Cosmic Disclosure](#)”. I'm your host, [David Wilcock](#). And I am here with **Corey Goode**, our Secret Space Program insider, and we have our special guest Dr. **Bob Wood**, who is giving us some very, very interesting information about his background in the history of UFOlogy in some very interesting historical periods, as well as his direct contact beginning in 2009 with **William Tompkins** who has validated an incredible amount of **Corey's** testimony.

And just the correlation between **Corey Goode** and **William Tompkins** alone is something that could potentially start a wildfire all over the planet in terms of Full Disclosure and understanding that the

things that we're going to be talking about in this episode are absolutely true as far out in sci-fi as they may seem to the uninitiated.

So **Corey**, welcome back to the program.

Corey Goode: Thank you.

David: And Dr. **Bob**, it's good to see you again.

Dr. **Bob Wood**: Yes, thank you.

David: So let's just go back really briefly, and I want to bring up J. Allen Hynek.

Bob: Yes.



Now, here's the guy who actually coined the term “swamp gas” as a part of the Project Blue Book.

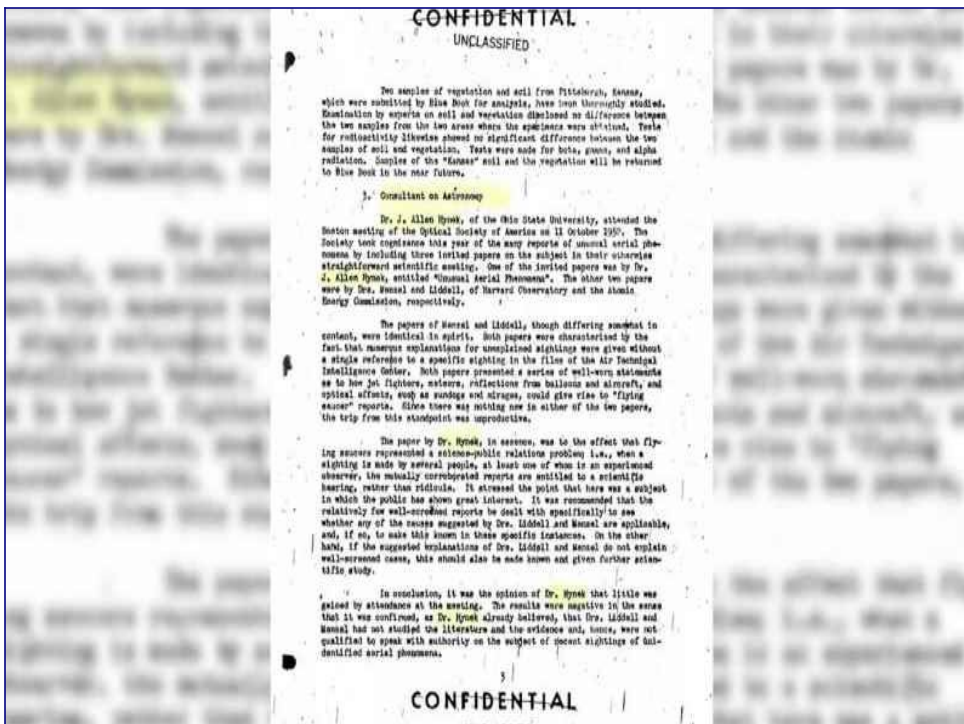

Now, what you may not know, or maybe you do, is that I've been working with Jim Hart, who wrote the movie "Contact", coauthored the screenplay. It was eight years of development total in that project, and he was working with Carl Sagan. And as a result of these high-level contacts, he had exposure to J. Allen Hynek.

Bob: Yes.

David: And what a lot of people don't know is that J. Allen Hynek realized that he had been duped by the U.S. government, and that he turned around.

Do you find that these people who are specializing in disinformation eventually do come around after they do more homework? Do they realize that they've been lied to, that they were used as pawns in this greater chess game?

Bob: Well, J. Allen Hynek actually swam in my swimming pool during that time, . . .

David: Really?

Bob: . . . between '68 and '70 when I was doing this research.

David: No kidding.

Bob: And so I knew both J. Allen Hynek and Jim McDonald, even though they didn't really talk to each other very much, very often.



David: Wow!

Bob: The first involvement I had with people who were disinformation guys was Bill Moore. And Bill Moore, as many people know, was given some information that was apparently controlled, and he leaked it knowing that it was not correct.

And I wound up buying all of his material from him. Actually, I made him an offer. I said, how much do you want to sell everything you got? And he said, "\$1,000". And so I said, "Okay".

David: Wow!

Bob: I wrote the check and went down to his place in Hollywood and got it from him. I said, "Is this all?" And he said, "Yes."

Well, I cataloged it. And it turns out there was nothing really revolutionary in anything that I got from him.

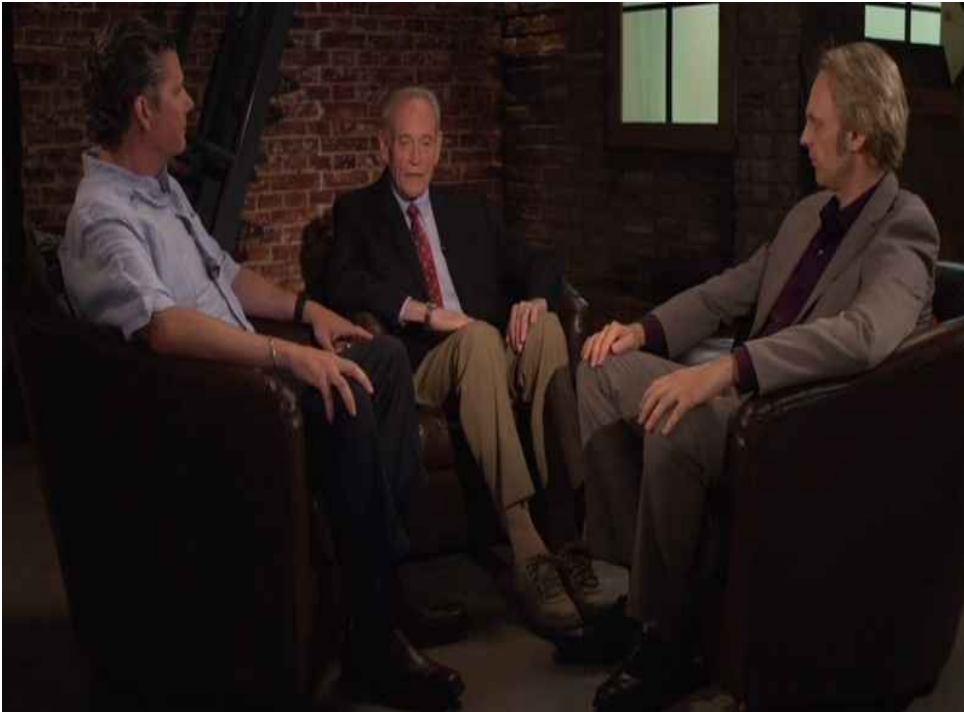

Other people say that the documents that I have have been craftily architected in order to – by a group of CIA guys, for example, who you could imagine a room full of 20 people who are all experts in creating false documents.

So that scenario is hard to wave off, but there are so many little subtleties in the documents – the stamps, the timing – that, in my judgment, the vast majority of the documents that I have are really authentic.

And so I'm willing to accept there's an occasional one that might have been partly phony. And that happens.

David: Well, and **Bob**, isn't it true that these are exactly the types of proofs that the hardcore scientific types are asking for? And you have that. You have documents that have been verified.

Bob: That's right.

David: We know when they were done, and we know what they say.

Bob: That's right. The skeptics, however, come back with the usual response that, “Well, you can't really do much with copies. You got to have the originals.”

So I say, "Well, I have originals. Two cases, I have originals. Let's look at only those, and then go through one of these originals which deals very deeply with the assassination of JFK and the relationship to UFOs."

And then they really don't have responses to that. But, I mean, the authenticity issues then become harder for the skeptics to do that.

David: Bob, you dropped the bomb. You cannot race over that. What did it say about JFK and UFOs? What does the document say?

Bob: It's an eight-page document, and it had tabs. Actually, there were eight tabs. And each tab was designed to deal with a different aspect of the secrecy problem.

It was written through MJ1 through MJ12.

David: Oh!

Bob: Yeah, it was a Majestic. In effect, it said, if, in fact, it becomes clear that he's really going to leak everything, then he ought to be taken out.

David: Wow!

Bob: It's different words.

David: Everything about the UFO cover-up.

Bob: They didn't mention his name . . .

David: Oh.

Bob: . . . but they used the Secret Service

Corey: POTUS.

Bob: POTUS.

Corey: Oh, yeah, they used to have code names for him.

Bob: Yeah. Yeah.

Corey: Were you involved in authenticating the MJ12 documents?

Bob: Yes, nearly all the documents that I had were MJ12 or Majestic or Magic.

Corey: Okay, so when the people received it, you were one of the people that looked at the documents to . . .

Bob: All the documents I had were leaked from various sources. There are three or four different sources.

David: Now, when you say 'leaked', this doesn't mean that people filed a Freedom of Information Act request . . .

Bob: No, no.

David: . . . and they got it legally through the government.

Bob: There was one . . .

David: Those were squirreled away.

Bob: . . . one document that then Cooper got legally that says "MJ12" at the bottom.

Corey: Oh, really?

Bob: Yeah.

David: Wow!

Corey: Okay.

David: But the others were pulled out?

Bob: The others were just given by . . . you can speculate exactly how, but I . . . There's one case . . . One guy showed up to Tim Cooper's door and gave him a box full of stuff. And it was clear that he was cleaning out his files just to get rid of them. Ha, ha, ha.

David: Ha, ha, ha.

Bob: And another document, which was an encyclopedia of flying saucers written by Charles Bowen, was a document that had been created as a history of the subject as of 1950s, I think, something like that, and was sent to the Air Force to make sure there was nothing in there that was classified.

In 1994, it was mailed to Timothy Cooper from Fort Meade.

David: Hm.

Bob: And actually it was original, and it was stamped “Top Secret”. But it had on it notations like “what is DM doing?” Where they were saying “Don Menzo was telling his classes that there were aliens.”

David: Hm.

Bob: So this is the kind of wide set of experiences I've had in authenticating documents, and all of them can be attacked by skeptics. That never ends. There's no way you can ever get rid of it completely.

Even the latest thing that I thought has real potential is forensic linguistics, where you can take a large number of words that a person has written and then compare it, . . . say, make up two or three different people and then compare the question documents' words against those.

And then, depending on the phraseology and the use of verbs, commas, and stuff like that, you could say the probability that this person wrote it is much higher than that one or the other one.

Corey: And you can tell what era they wrote it in by the phrasing and everything.

Bob: Yeah. Yeah. So that's one technique I used just once.

David: Well, **Bob**, let me ask you this. Documents and validation, obviously, would represent one of the two critical aspects of investigative UFOlogy. I mean, maybe there's three. Okay?

So you have your documents. You have eyewitness sightings. You know, is there a pilot's report? Is there a ground sighting that correlates with the pilot's report? Are there landing tracings?

Let's just talk about that briefly. Did you go through your due diligence on some of these documents in terms of trying to find out if there were . . . Were any of them involving sightings that you could then

validate that the sightings happened? Or did you study people that had sightings and try to correlate pilot sightings, ground-based sightings, landing traces, that kind of stuff?

Bob: That's a good question because it makes me think about the fact that most of the documents I'm trying to authenticate don't deal with sightings at all.

David: Oh, okay.

Bob: They really deal with the covert programs.

David: Okay.

Bob: But the fact that I became involved after I retired and did this movie "The Secret" and continued to give papers, my son started a crash retrieval series, and he did seven years' worth of crash retrievals in October. It had a wide audience.

And so for these crash retrieval meetings, I wound up giving a paper each time on something or other and established myself as a person who was willing to dig as deep as necessary to understand the subject, one of which, of course, was the alien viruses.

One was Stringfield. What does Stringfield really say? What was he trying to say?

And so I established myself as a person of some integrity, I think. And that's why Bill **Tompkins** called me up.

David: Oh, okay.

Bob: He said, "I hear you like to look at UFO stories." And I say, "Yeah." I said, "Who are you?"

So he explained to me who he was, and he said he'd been trying to write a book for 10 years, and he'd given it to various people to write and gave me the names of some of them.

Corey: I'm sure that description he gave you of what he did . . . your eyebrows probably raised about that high.

Bob: Well, he didn't really tell me that much at the beginning of the conversation, but he did say that he was . . . I think one of the reasons . . . he knew where I had worked. And he'd figured out that I worked there at the same time he did.

David: Wow!

Bob: So soon as I found out that he was there from the time I was there, then I got very interested. And I started to ask him, "Well, did you know this guy, that guy, and so forth." And every time I asked him a specific question . . . I asked him to describe the room or the orientation of the building, stuff like that. And he had it all.

Corey: Wow!

David: That's amazing.

Bob: So then I got really interested. And I said, "Well, tell me more of your story." And he said, "Well, okay."

So he . . . To get it, since he didn't do email, I had to go visit him. So I went to visit him. It turned out at that time, he lived in Oceanside, California, which is where my daughter lives. So it was just a quick stop when I was seeing my daughter to go over and meet Bill **Tompkins** and his wife Mary.

And they made me feel very welcome. And that's when I got the first stack of the manuscript, when I read the overall scope of what he wanted to say.

David: I want to run two things by you real quick. First of all, you've said to me, based on your discussions with Bill, that "Selected by Extraterrestrials" is only the first of what he plans to be a trilogy of books because there's so much data that he has to disclose.

Bob: When I first met Bill, he had in his mind six books planned.

David: Wow!

Bob: And I subconsciously concluded that six books from a guy who hadn't published one was probably too many to think about.

David: Right.

Bob: So I just said, “Let's think about the first book, Bill, and how we're going to limit it.” He was talking about things that went on over a long time, from '70 to now. And I said, “We got to limit it, so let's pick a time.”

So he wanted to go beyond when he left Douglas up to when he went to TRW, because he says, “The TRW story, that's going to be the second book – what REALLY went on at TRW.”

I said, “Well, that sounds good. Yeah. Let's make that the second book, but let's limit ourselves to one up to that point in time.”

So we took material that was in that time zone, time frame, and, actually, I worked with a guy from the University of Michigan who had started on this, and he gave up. So he gave it back to me. And so I just started to attack it.

David: The degree to which Bill has validated his involvement in technical programs is staggering in this book.

Bob: Well, Dave, when I first got the manuscript, I asked myself the question of should I try to tell Bill what he ought to write for his autobiography? Or should I just let him write what he wants to write? And I concluded that the latter was the right way to go, at least on the first book.

So he included a lot of technical material having to do with the design of the Apollo and the S4B spacecraft that I was familiar with at Douglas, and his interaction with NASA, and the fact that he was interacting with DuBose and von Braun, of course, are relevant.

David: I want to ask you a really direct question, and this is kind of a wild card. In the book, there's some very, very strange stuff about the early period of NASA, the early beginnings of it, in which Bill is involved. And they're having sex parties at these people's houses where everybody's naked.

And then he goes into this very strange room with very strange curtains. And it seems like it's black magic or something that's being done in there.

Could you tell us a little bit about that part of the book and what do you think was going on there?

Bob: Well, my recollection is what you're probably referring to are the parties at Douglas Aircraft Company, not NASA.

David: Right. Oh, okay. Right.

Bob: And he claims that the executives at Douglas would try to have these parties in order to get control of their employees so they would, in effect, be able to be blackmailed or do what they wanted to do.

Corey: That's an old, old, old tactic.

Bob: Yeah, right. Now, I knew all the people he's talking to. When he gave me the names in the book, I asked him, I said, "Well, who are these guys?"

So he gave me a list of names, and names for the book, the real names. So I have that list. And I knew some of them very well. A couple of them were my bosses at a later time.

However, it turned out that I was fortunate that my wife at that time – I've only had two wives – but my wife and I decided that we would never become involved in company social activities.

Corey: Imagine that.

David: Oh, wow!

Bob: So it turned out it was a lucky break. Ha, ha, ha.

David: Ha, ha, ha.

Bob: What can you say?

Corey: You probably would have turned around and left anyway.

Bob: Yeah.

David: That was actually why I was asking. I was really curious because he describes wandering into . . . I mean, you didn't say it, so I'll say it. He describes people having sex in these big mansions, wandering into rooms where it's all like blood red and black decor, black curtains.

Bob: Yeah.

David: And it looks very much like a satanic type of ritual room.

Bob: That's an association I had not yet made – the satanic aspect – but that might well be the case.

David: Yeah.

Bob: I just kind of went over those areas and decided, well, I was lucky I avoided all that stuff.

David: Right.

Bob: And I was lucky that Bill avoided it, too. Now, I asked him . . . well, that question . . . “Well, were they successful in seducing you or not?”

He said, “No, they did not.”

Corey: But with the Germans in the space program, they used black magic along with science.

Bob: Yeah, that's a good point. Yeah.

David: Well, let's go into for a minute, because he does jump around a lot in the timeline in the book.

Bob: Right.

David: It's a little frustrating to try to read it and figure out what he's talking about.

Bob: Right.

David: He's referring to, for example, some very . . . He's referring to physics discoveries that were apparently classified that I'd never heard of before regarding antigravity and faster-than-light speed propulsion. But then that just shows up, and he doesn't really set up who invented this stuff or anything.

Bob: Yeah, the discussion of the book that relates to **MTM 222, 622**, is interesting to me because, in my judgment, Wolfgang Klemperer, who was the scientist he worked for, whom I knew personally, was my boss, actually, my boss's boss . . .

David: Wow!

Bob: . . . he came from Germany in the mid '30s, and he was not a Nazi. He was a good guy.

David: Okay.

Bob: But in my judgment, he was able to bring with him some classified stuff about how antigravity works. And he had . . . it was in three volumes, three or four volumes, I think, according to Bill.

And I said, "Well, can I see that?" And he said, "Sure." So he gave me the unclassified version, which I read cover to cover. And it doesn't say anything.

Corey: Being a physicist, I'm sure you did. Yeah.

Bob: It doesn't say anything about how you could do it. But I've concluded that the think tank that they were in, that Klemperer was using the classified versions of the German technology in order to help the Navy figure out how they worked.

And when the Douglas management, which is what Bill says, would not support the vault [think tank] that was under Elmer Wheaton's control to do unusual stuff because, like he says, the manufacturing part of the company was very powerful in influencing the decisions by the CEO.

That's when Wheaton decided he'd go to Lockheed, where Lockheed was getting money from the Navy anyway.

David: Hm. I guess what I'm trying to drive at is sometimes reading this book, I feel like I'm reading other people's mail, like I'm barging in on something, and I want to know more. Was he restricted from saying certain things? Did he have to get this book vetted out through authorities?

Bob: No. The book that we wrote?

David: Yeah.

Bob: Oh, no.

David: Okay.

Bob: There was no approval by anybody as far as I know. And in my own case, I've never been threatened by anybody to stop talking about what I talk about.

David: Okay.

Bob: And the reason for that, in my opinion, is because they figure that people like myself talking publicly is just harmless. They've already planned for that. They know it's going to happen. They've got a way to counter it.

They can keep the public in the dark and let a few people say what they think.

David: Sure.

Bob: Yeah.

Corey: Yeah, through mass media.

Bob: Yeah, right, through mass media control.

David: So let's, in the time we have left . . .

Bob: Excuse me . . . So I really think that they were using some technology that came from the Germans that they were brought there by Wolfgang Klemperer in that vault.

David: Okay. So as far as the book represents . . . Let's just get clear on this. They already had this elaborate body of physics that suggested that they could build a large craft. They could basically build it in a base here on Earth, turn on these anti-gravity systems, just let it rise up into space.

And then they would have the ability with the technology that they've already developed in these physics breakthroughs to be able to fly it around in our solar system and beyond. But this is something that . . .

Bob: I think that's a fair summary of what the management of the program had in mind.

David: Okay.

Bob: But I don't think Bill ever grasped that at that time . . .

David: Oh.

Bob: . . . at that level. You have to emphasize that Bill, fully respectfully I say, is not a technical person. He was a super marketing guy, and he knew exactly what technical people should be told to do. He was

an excellent manager of technical people. But as far as being aware of equations, no, he wouldn't be able to deal with that or have any interest in it. But he was very sensitive to who saw what.

Corey: Right. And I'm sure he had an overall grasp of what people were talking about even though he didn't understand the fine details.

Bob: Right. Right. And he had a . . . In my opinion, he was definitely a very good system engineer. He would understand how these had to be integrated together, even though he knew he didn't need equations to make them talk to each other.

David: Okay. I want to ask you another thing that . . . It's just something that people who read this book might kind of stumble over, is why do you think these guys, these high-level executives who you personally knew at Douglas Aircraft – you knew these people – why do they go up to Bill **Tompkins** and throw him these seemingly impossible puzzles to solve and say, “We need you to design a ship that's going to be two kilometers long, that flies through our solar system, and we need it by the end of the week?”

Why are they doing this to him? Was there some kind of intuitive thing that they felt he had because of the way he built ships when he was a kid?

Bob: Well, he certainly had a remarkable memory . . .

David: Right.

Bob: . . . as evidence by the fact that he built the ships with great accuracy. Basically, he was a draftsman. And he admits and claims that he was . . . started out as a draftsman, but he was a very creative draftsman.

He could see how people would think something here, think something there, and he knew that they could use equations to make it happen. But they would ask him to do . . . In my opinion, they would ask him to draw pictures of the answer. So he was really a picture guy.

Corey: And then they would go in and figure out how to put components in and make it work.

Bob: Yeah. Yeah.

Corey: Do the environmental and propulsion.

David: Okay.

Bob: Now, there's one sketch of the book where it was the front of a DC-8, or something like that, where it's a beautiful example of how his drawing can go into exquisite detail, capture every little element that's critical and make it just right for the engineers who needed it.

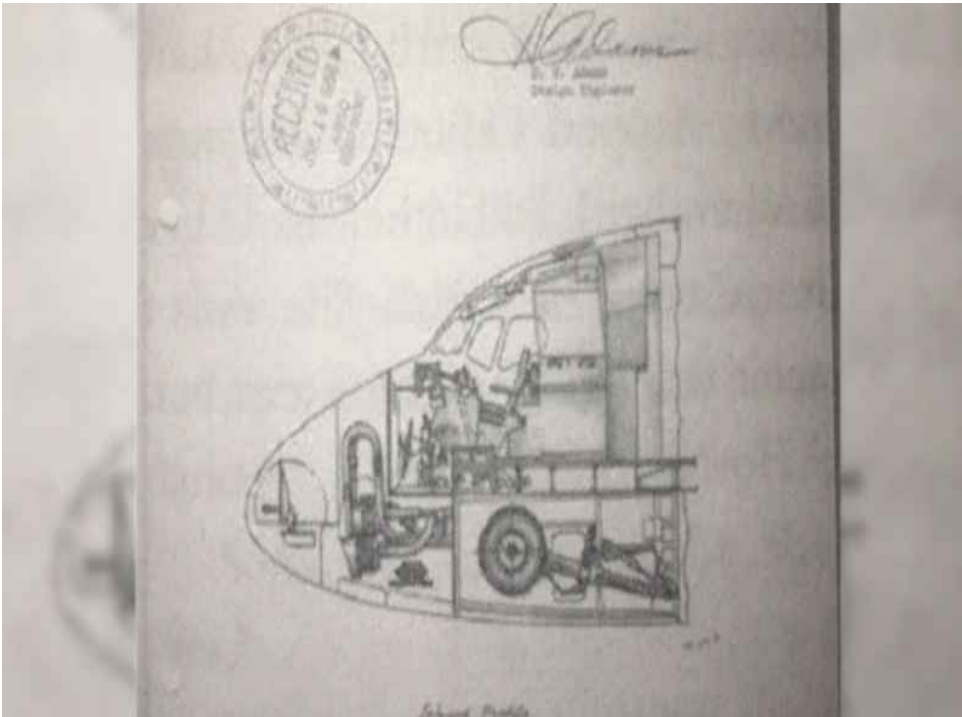

In fact, I knew the guy who he's talking about.

David: Let's go talk now about this really over-the-top information that he was getting through these 29 spies from America embedded in the German space program when he was getting those 1,200 briefings from 1942 to 1946.

Could you just summarize for us? I know there's a lot of data, but summarize for us. What was the big picture that he started to put together during that time based on what these embedded spies were telling us here in America?

Bob: Well, Dave, I'll give you my best impression of what was going on in my words as I'm learning it, actually. I talked with him just this morning and learned something I didn't know that would be relevant to your question.

David: Sure, great.

Bob: I didn't know there were 29 until this morning.

David: Oh, okay.

Bob: Ha, ha, ha. Apparently, you guys have known that for a while.

David: Yeah.

Bob: But my impression is that this process was highly structured, that the Germans would say what they learned, it would be transcribed, it would be typed up, it would be reviewed, it would be understood by Bill, and then he would be asked to take this information either in the form of a request for proposal from a contractor or in the form of information to give to a Navy base for them to cogitate over, or in some cases to be given to a university.

He said in some cases, for instance, Caltech had people up at China Lake who were assigned there. He'd deliver something to Caltech via China Lake.

David: Wow!

Bob: I thought that was very interesting that the university linkage at the top-secret level was something that most universities have no concept could have been going on.

Oh, one thing I just learned this morning was he emphasized that none of them were stamped "Top Secret". None of them were classified. None of them were stamped with any classification marks, which was apparently the way Forrestal wanted it run.

Corey: It also allows them to disseminate it to more people if it's not marked.

Bob: Right. Yeah, and so they weren't stuck with the normal, formal Navy procedures of controlling classified information.

David: What's the story? What's the big picture? What was going on in Germany? Did they have a secret space program? Were they in contact with extraterrestrials? What were these people telling us? What was the story?

Bob: Those superior questions are exactly the questions I'd like to get the answers to.

David: Oh.

Bob: Instead of giving you answers, I'm afraid I still have to ask the questions. Because as far as I could tell, from what Bill is saying, it was quite a variety of different kind of information. Sometimes they were talking about communications.

Sometimes they were talking about physics. Sometimes they talk about UFO designs. Sometimes they were talking about time travel. I mean, things that would all blow your mind, but there was such a wide variety of things that he said that Rico Botta would write a little note on some of these packages in his own handwriting to the officer in charge of the base saying, "I know you're not going to believe what's inside, but it's really true." That was significant.

That's one of the things that Bill just told me in the last week or so.

Corey: And each of the 29 spies had different specialties and brought information based on their specialties?

Bob: Apparently. I don't know.

Corey: Yeah, that would make sense if they had such different information.

Bob: Yeah, actually, the book "Selected by Extraterrestrials" dealt with the idea that he was involved in as a courier to these packages was a very, very tiny part of one chapter, I think.

David: Right.

Bob: Whereas the interest today is very strong on what were the details of what he did for those four years and what information was being transmitted and learned.

David: Yeah.

Bob: And that will be the content of the next book.

David: Okay.

Bob: That will be in there. And I think the next book will have the answers to your questions, hopefully.

David: I just want to drop it out there because we have Salla, who's already disclosed this in video interviews. And we also now here at Gaia have interviewed him, and he has spoken about a big picture,

which is that the Germans had apparently developed contact with reptilian extraterrestrials, that those reptilian extraterrestrials had large facilities under the ice in Antarctica, . . .

Bob: Right.

David: . . . that there was a secret space program involving the engineering of disks that could fly with antigravity, and that these reptilians were interested in creating an interstellar invasion force with the Nazis to essentially conquer and colonize other worlds as well as the Earth.

Bob: I agree with the first four things you said, but I've never had any exposure to the last thought . . .

David: Okay.

Bob: . . . until just now.

David: Well, since I just dropped that on you, how do you feel about this story, this idea that there could be reptilian extraterrestrials, that they could have helped us build the space program?

Bob: Oh, yeah. Oh, yeah. I think that's all straightforward, and I think Bill is right that the reptilians did help the Nazis and that they do have an underground base in Antarctica. I think it's there today.

I haven't figured out exactly how the Nazis and the New World Order work together, if they do, but somebody's in charge of something. But I don't think they coordinated it very well.

David: And I've got to tell you, **Bob**, the thing that blows my mind is that everything that I just summarized is exactly what he [pointing to **Corey Goode**] told me starting in October 2014.

Bob: Yeah.

David: And now we got a guy independently who's saying exactly the same stuff – bases under the ice in Antarctica.

Corey: I've seen them.

Bob: You've seen them? So these are not just under the ice, they're under the land, too?

Corey: These were under the ice that I saw. It was in Northwest Antarctica where all of the thermal activity is.

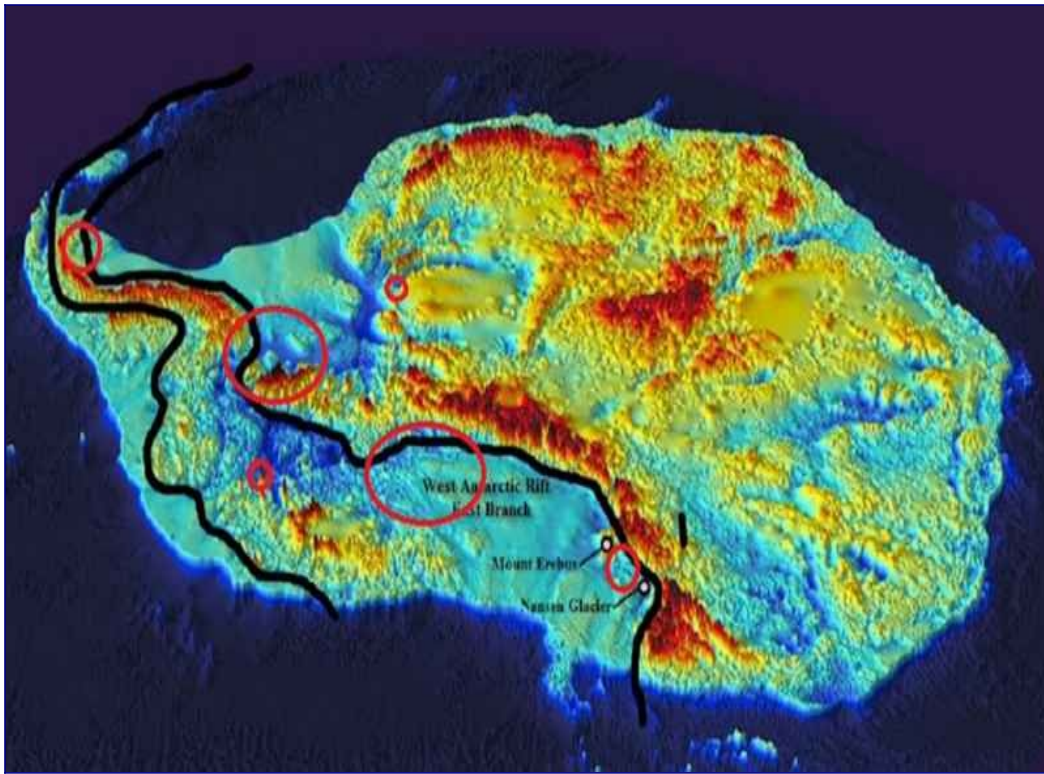

And underneath the ice, there's thermal heat from the Earth, and it made, basically, like a giant igloo.

Bob: Uh-huh.



Corey: And parts of it, they cleared out with some sort of explosions and other engineering to make it fit what they needed. But the ceiling was in areas 300~600 feet high above the surface. And the mountains would go up and disappear into the ice, the top of the ice.

And on the surface of Antarctica, the actual ground is where they had a bunch of those round-top iron buildings like you see at an Air Force base. There were a bunch of those. It was an industrial-type city.

And their light reflected off the ceiling of the ice cavern.

Bob: Did they know you were there?

Corey: No. No, we were flown through. It was a reconnaissance flight.

Bob: Okay. So you were not an invited guest?

Corey: No.

Bob: Ha, ha. So how many Nazis do you think are there now?

Corey: Well, most of what they had was also under the ground. There were entrances to the underground.

Bob: Right.

Corey: So there was quite a bit going on down there.

Bob: Right.

Corey: This seemed to be more of an industrial area where they had giant black ships that are electromagnetically propelled that would come up. And they were the size of container ships.

Bob: Wow!

Corey: They were huge. And they were off-loading supplies. So that might have been . . . It could be like an industrial and like a port.

David: So I think it's really cool that you're here because **Tompkins** and you both have such a valuable part of this puzzle.

Bob: Well, I think it's cool that I am here, too, because in the last month I decided that if there's one thing I wanted to do before I no longer can do it is to write a book titled "The Secret History of the United States" where we cover not only the UFO story, but what really went on in 9/11, who really did kill JFK, and all those other things that are alleged conspiracies, where every skeptic has tried to tear them down.

Corey: Sounds like a good book.

Bob: And the thing that worries me is that it's hard for me to imagine that UFOs would be just one chapter in a chapter of 10.

Corey: It's a very small part of the equation.

Bob: That's right. But the challenge is really important because what you're saying is that there are some guys, including some aliens, who are really trying to make the world better and to give benefits to people so that things like a slave trade, whether it's galactic or local, it would go away.

Corey: Correct.

Bob: And I'm excited about that.

Corey: I am too. It's past time.

Bob: Yeah, so whatever I can do that would help, that's what my goal is. Actually, that's what the goal of MUFON is too. I mean, I don't know that those phrases, "world a better place", is right in there, but I think it is. You want to . . .

David: We've had so many people, **Bob**, on the Internet who have flamed us. And they don't really take the time. They haven't watched the show. We got a year worth of episodes of me interviewing him [**Corey Goode**] for half an hour a week.

Bob: Wow!

David: And he never repeats himself. There's so much data.

Bob: Well, you're [looking at **Corey**] obviously a very intelligent guy.

David: But this was his life for 20 years.

Bob: Yeah, right.

David: And it was just boring everyday stuff he was doing, the things that he encountered, the information he learned. It was just as ordinary as a child growing up in American educational system, except it's very different information.

Corey: It becomes the new normal for you.

Bob: Yeah.

David: And I think that's where we're heading. I think the things that he knows are going to become things that everyone knows. And you here as an independent, with your own background, you very much bolster **Tompkins'** testimony. You've seen the same people

Bob: Yeah.

David: And you're bolstering **Corey's** testimony.

Bob: Right.

David: So that helps people jump that gap of saying, "My God! Maybe this is true. Maybe these guys are actually not blowing smoke, but there's a big fire where that smoke is."

There's something here that's going to change the world for the positive, and I believe that's what's happening.

And I want to thank you for being brave enough to step forward, and to put your name out there and put your reputation on the line talking about these very contentious subjects. I think you're a hero, and I'm very glad that you decided to be on our show today.

So I honor you, sir, for coming out and doing this with us. It's been truly remarkable.

Bob: Thank you. And it's been fun, too.

David: Thank you.

Bob: Thank you.

Corey: It's great meeting you.

David: All right.

Bob: Yeah, really, it's true.

David: And I want to thank you out there for watching. You're a very big part of this. Your support of this network and of this program is vital to the disclosure effort. So tell your friends. Let them know about this. If this is getting you excited, help spread the word.

This is "[Cosmic Disclosure](#)". I'm your host, [David Wilcock](#), with special guest Dr. **Bob Wood**, and, of course, **Corey Goode**. And I want to thank you for watching.

Cosmic Disclosure: The Earth Alliance Strikes Back

Season 6, Episode 1

[David Wilcock](#): All right, welcome back to "[Cosmic Disclosure](#)". I'm your host, [David Wilcock](#). I'm here with **Corey Goode**, and we're going to get into some of the episodes that you consistently have told us you love the most - updates about the latest and greatest, and weirdest things that are happening to **Corey**.

So **Corey**, welcome back to the show.

Corey Goode: Thank you.

David: So you and I have actually gotten in a lot of trouble because we had gotten information about a war that was taking place over Antarctica, and we had not disclosed that. So could you start out by telling us what was the nature of this war? What happened? And what were the consequences for you for not reporting on it?

Corey: Well, it had to do with the war and what was found under the ice shelf of Antarctica.

David: Okay.

Corey: It had been reported to me that, for some time, they had seen these strange spheres that were about 90 feet in diameter that were . . . that had little port holes around it that were being seen over Antarctica.



I had gotten several reports of it, but it wasn't confirmed until I talked to members of the SSP Alliance.

David: Hmm.

Corey: These appeared to be just reconnaissance. They were just watching what was going on down in Antarctica. Well, what led to the battle was that six of these Dark Fleet cruisers [The Dark Fleet is the military branch of the Secret Space Program, the SSP] that were teardrop shaped, very large, had left the water off the coast of Antarctica and were headed towards outer orbit as if they were leaving.

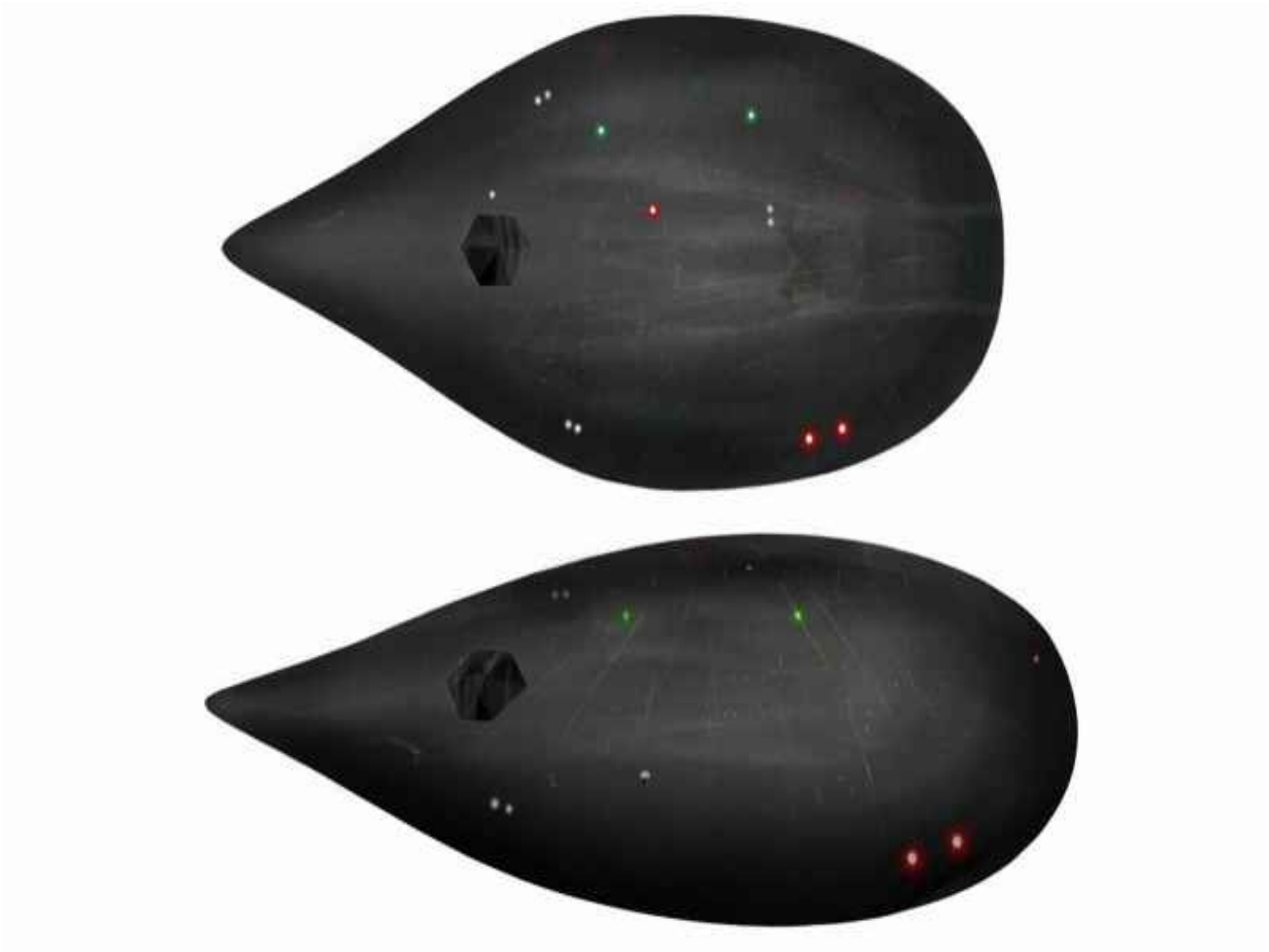

David: Now, is there a barrier around the Earth at this time? Could they theoretically have left?

Corey: Yes.

David: But the outer barrier around the solar system is still there?

Corey: Correct.

David: So for some reason they might feel that Antarctica isn't a good place for them to be anymore.

Corey: Right. They were trying to leave to go to one of their other bases in the solar system.

David: And I remember one of the really fascinating correlations with **Pete** Peterson was that, when I mentioned to him these spheres with the port holes around them, he actually saw one of those inside a hangar at some point in his career and said that the port holes were glass, that you could see inside the ship through the port holes.

And when we discussed it, he was fairly confident that they might be these cosmospheres that Peter **David** Beter reported on that the Russians have.

Corey: That's what was reported to me, that they were most likely Russian.

David: Oh! Okay.

Corey: Yeah.

David: So that was one of the things that fascinated me, because we got two independent points of correlation on this whole . . . what the spheres are.

And so this would be, apparently, part of what we're calling the Earth Alliance that . . .

Corey: Right.

David: . . . was taking action against these Dracos.



Corey: Well, and it continued, because as the two lead craft were getting in the upper atmosphere, all of a sudden dozens of what were described as Chevron-shaped craft about the size of a normal jet fighter, began to attack these vessels.

And there were flashes of light, explosions. and then these cruisers that were trying to escape, went right back down, went into the water where they had left from, where they had come out.

David: So what we have here is you have the spheres, which may be Russian. You have Draco, teardrop shaped craft that are attempting to leave the Earth from Antarctica. And then you have these very new and unexpected Chevron craft that arrive.

Corey: Right. And the teardrop shaped cruisers were Dark Fleet.

David: Oh, they were Dark Fleet, not Draco.

Corey: Right.

David: Okay. So I remember you telling me that there was something really unexpected about the arrival of these triangular craft, which they're calling Chevron craft even though they were basically triangular in shape. So what was it that was so surprising about that?

Corey: Well, they had very powerful weaponry, and no one knew who they were. It turns out that these were craft that the secret Earth Alliance had obtained. And they were using them to prevent these Cabal groups from leaving the surface of the Earth.

David: This is essentially something that changes the game, right?

Corey: Absolutely.

David: This is a very big game changer. Why was it such a game changer?

Corey: Well, now some of these Alliance groups on the Earth have advanced technology. They basically have their own secret space program now.

And these assets are the ones like you would get from the ICC. They were very advanced, very new technology. And these craft were built by defense contractors.

David: But those defense contractors in the ICC are not necessarily working with the ones that built these craft on Earth.

Corey: Right. And it's unknown how they obtained them, but there were dozens of them that attacked these craft.

David: So what was the effect of these ships being shot down? That's obviously some kind of a tipping point in a war.

Corey: Well, it sent shock waves through the Cabal. It also sent shock waves through the SSP Alliance. They're not used to things popping up on the radar that they don't have a full understanding of.

David: Right. What do you think is the greater socio-political struggle that's going on? Why would the Dark Fleet be trying to leave the Earth now?

Corey: The same reason why so many of these syndicate groups have been heading down to Brazil and Argentina to go into these underground bases that are sending them below ground through fissures that are filled full of water. They travel all the way to Antarctica.

They're looking to escape from something. So they're expecting some sort of an event to occur, and they're trying to escape from it. And apparently they decided that it was better to get off of Earth and out into the furthest part of the solar system.

David: Do you think that there are changes going on that could lead to some sort of data dump or some sort of big epic shift in all this geopolitical struggle that's going on?

Corey: That's been the rumor or the threat for some time, but the Cabal groups have taken steps to minimize the impact of any massive data dumps.

David: So this was a curious situation, because you and I both got in trouble – big trouble – for not revealing this battle intel to the public, but yet most people would say, “Well, what does it matter?”

Corey: Well, it wasn't the battle intel that was so important that we deliver. It was everything that I had reported on my tour under the ice: the location of these bases, what was under there.

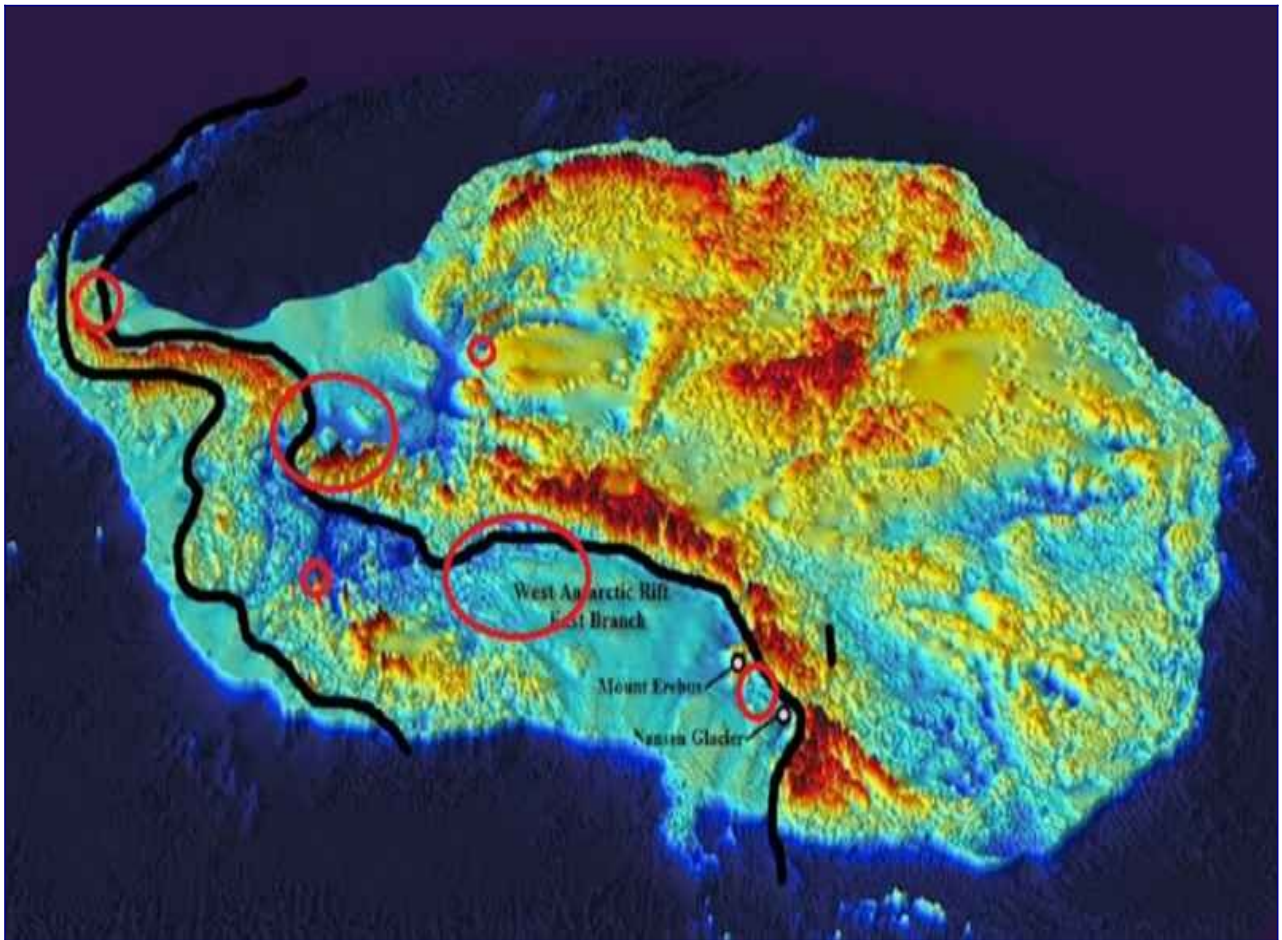

Because at the time, obviously, we had Alliance assets in the theater operating.

David: Oh.

Corey: So that was a perfect time for them to take further action.

David: So are you saying that, because we didn't leak the intel fast enough, that the Alliance could not make moves, because they didn't know where these things were that you had seen?

Corey: Right. Correct.

David: What was the Alliance's opinion of you and me as a result of that not getting out?

Corey: Well, shortly after that is when they sent in The Wrangler, who, as you said, tries to convince underperforming assets to perform.

David: So one of the things that the viewers have said is that in some way this network was suppressing our release of this information. And could you just address that for a moment as to whether that's what happened?

Corey: No, Gaia had no idea of the details of the information yet because we hadn't reported them in a release or an update. So it would have been some days or weeks after that Gaia would have had us, you know, do an episode on it.

David: And I was equally as guilty as you because I was very preoccupied with finishing my book, and I had shoved everything else off to the side. I was working sometimes until 5:00, 6:00 a.m. in the morning. I just didn't have any time to write these updates either. So there was no written form of them, and we also . . . the way that the taping worked, it just didn't work out.

Corey: Correct. Yeah.

David: So very shortly after The Wrangler was turned down, we had the Contact in the Desert event. And this was the first time that you had actually gone to a conference where people knew who you were other than Conscious Life Expo.

Corey: Right.

David: This was only the second time that you'd been out there in front of a live audience.

Corey: Correct. Yeah.

David: So, could you walk through for us some of the strange things that happened once you got to Contact in the Desert?

Corey: One of the nights – evenings – I was sitting at my desk and, out of the skylight, I saw a blue light. And I looked at it, and I thought maybe it was a star that the curvature of the glass was refracting and making it look blue.

And I stood up, and I looked, and I decided to go outside and take a look. And I went outside, and I saw the blue light. I came back in, got my phone, went back out, and then it was moving and blinking, heading across the sky.

David: And it hadn't been blinking before?

Corey: No, it was solid blue.

David: Really? Okay.

Corey: Right. So I went . . . I think I texted you or called you.

David: Yeah, you texted me. and you were very, almost ridiculously pressuring me to go outside.

Corey: Yeah. “Go outside now!” kind of thing.

David: And I'm like . . . and you didn't say what it was.

Corey: Right.

David: And then I went outside not knowing what to expect. Let's start with you. What was your observation of it from there?

Corey: Well, I mean, I had seen blue spheres many times – you know, blue orbs.

David: Right.

Corey: But this one was obviously going to be a . . . I thought it was going to be a mass sighting event, so I was pretty excited. So I recorded what I could, with my iPhone, of it. And it shows it a little bit.



6/3/16

It was exciting, because it was occurring when there were like 5,000 people down below.

David: This is something that I also saw, and what was interesting was that I had someone staying with me as an assistant, and she saw a cloud of blue energy over my head, more like a spiritual sighting, right before you had sent me that text.

Corey: Yeah, that's pretty weird.

David: And I ended up going outside, and I observed this object for over an hour. And had you heard that a lot of other people saw it, because I certainly . . . ?

Corey: Yeah. The next day we had a lot of people report seeing a blue sphere or orb in the air.

David: Right.

Corey: Some people saw it blinking. Some people saw it solid.

David: What do you think was actually going on with this blue orb?

Corey: At the time, I really didn't know, because it didn't seem really that interested in me.

David: Was there something that came out later on that made it more obvious?

Corey: Yes. Later on I was told that during that time period, that certain people, including yourself, had gotten some sort of a download from it when it was blinking.

David: Suggesting that, maybe when the person I was with saw this blue energy over my head, that that could have been when it was happening perhaps.

Corey: Yeah, it was a weird correlation.

David: So what was the next thing that happened to you after you saw the blue blinker?

Corey: Actually, it was the next morning. I was laying in bed, and I started to hear a chorus of voices of all ages, all genders – both genders. And I think it was four times that it repeated this. I heard, “We are the messengers and facilitators of the One Infinite Creator”, over and over, like four times.

I got up, and I was wondering, “What the heck is going on?”

I went outside, looked around, looked up in the sky, looked all around the terrain, didn't see anything.

David: Well, and that sounds exactly like a line you'd hear in “The Law of One”.

Corey: On that topic, I went and laid back in bed. And I'd been carrying around “The Law of One” for a while and hadn't been able to read it. When I'd try to read it, the words would hover above the page. I couldn't retain anything. It was very discouraging.

Well, I picked the book up this time, and I started reading it, and I was able to retain everything. And even stranger than that, in my communications with Tear-Eir after that, he started communicating with me in terminology very similar and some identical from the book.

David: Well, let's go back to that original meeting that you had in front of the SSP Alliance. What was one of the first questions that the Alliance asked the Blue Avians when you were there?

Corey: “Are you the Ra from 'The Law of One'?”

David: And what was their answer?

Corey: He just had me repeat, "I am Raw-Tear-Eir."

David: And Raw is like Ra, basically.

Corey: Right.

David: So this seems to be a much more advanced presentation of the connection between "The Law of One" and what's happening to you. It seems like we've reached that point where it needs to be more solidified that this really is the same group. Would you agree with that?

Corey: I would agree with that now. In the past, you know, I'd always been a little leery of drawing that connection when I hadn't had the indication myself.

David: What was the next thing that happens to you in terms of new contacts?

Corey: Well, new contacts that I haven't reported . . .

David: Right.

Corey: Kaaree contacted me and gave me a little bit of an update on what was going on with this Wrangler character, that they were extremely triggered and had some sort of vendetta out towards me for some reason. They were reaching out to their different proxies, people that they knew, seeing what kind of access these individuals could give him to me.

David: And when you say 'they', you mean The Wrangler.

Corey: The Wrangler was reaching out to contacts, and he was asking these contacts what kind of access he could get through them to me.

David: So even though, ostensibly, the Blue Avians were blocking him from being able to access you, he was trying to pull strings and figure out how he could still work around that somehow.

Corey: Right. And that had been noticed, and they said that they were keeping a close eye on him.

David: Let me just ask you this. If we had published that intel in a timely fashion regarding Antarctica – if we hadn't have both been preoccupied with personal issues and writing books – what might they have been able to do that didn't get done?

Corey: Well, pull off a operation on these facilities under the ice.

David: What kind of an operation?

Corey: Well, either go in and take things away from them, or go in and destroy or attack them.

David: Wow!

Corey: Yeah. They knew that there was something going on under the ice, but they didn't know the locations of these installations.

David: Right. So Kaaree is now talking to you, and what was the method? Did the light flash in your room, and you get brought into the Inner Earth like before?

Corey: This is one of those etheric conference calls.



David: Like what we've been calling "The Construct".

Corey: Right.

David: So you're in kind of a white space?

Corey: Yes. Everything around you is white, except for . . . well, the chair is white too, but, yeah, it's white.

David: So she said that The Wrangler was trying to access you but was unable to.

Corey: Right. And she also informed me that the security groups that kept these facilities safe were extremely freaked out that they were not able to detect the Anshar bus during the reconnaissance and the fact that these certain locations were given out about what was under the ice.

David: Yeah, I would imagine that, if they had always thought that they could see any craft that come in, and then that craft is invisible, that would be very scary to them.

Corey: And they realize that if the Alliance, that had operations ongoing above them, had known all of this information, they would have had a very bad time of it from the Alliance coming in, especially in the advanced craft they have now.

David: Now, you also mentioned that Kaaree shared personal information with you. And, of course, everybody's going to want to know if there's any specific tidbits at all that you could give us about that.

You had mentioned that you were very depressed about The Wrangler. I saw that in you. You were in a very dark place at that point.

This guy had basically tortured you. So was she trying to give you some moral support, cheer you up?

Corey: There was some counseling going on there, but there was also a lot of talk about people that were operating in my sphere, things that were going on with them, and some very personal things.

David: Right. So did anything else happen in this meeting with Kaaree?

Corey: She did inform me that Gonzales was indeed away with the Mayan breakaway group going through their "healing" that I'd heard so much about.

David: And how did you feel about the idea that he was going through something like this?

Corey: I was happy for him, but I didn't think I would probably ever see him again, because he told me that, if he got a chance, that someday he may disappear abruptly and go off for healing. And he may never get the opportunity to say "Goodbye" to me.

David: So after this initial meeting with Kaaree, did you have any other meetings with Kaaree?

Corey: Yes. Over the weeks, there were small meetings here and there, but really nothing significant. It was more personal type of meetings.

David: Well, and you describe in the write-up on your website that you were in a very depressed place and didn't feel like you were of any value at that time.

Corey: Right. I was asking her why she was still coming to visit me so often to speak when I really didn't have anything to offer. I didn't have any intelligence. There was nothing going on to where I needed to be there as a liaison.

And she just . . . that big smile she gets on her face said to me that I would be useful again in the future.

David: You also said something about that she would be working with you.

Corey: She had told me that the nature of the mind meld that we had created in a connection between us that would have her looking in on me for the rest of my life, since she was going to live a much longer life.

David: So in your update, that brings us up to July 10 [2016], 3:40 a.m., as the next big event.

Corey: Yes.

David: So let's walk through that now. What happens at 3:40 a.m. on July 10?

Corey: Well, I hadn't been informed, I believe, on this one that there was going to be a meeting.

David: How would you have normally been informed before? What would have happened?

Corey: Well, Kaaree had been telling me to expect a meeting.

David: I see.

Corey: And then I was also receiving information in dreams to prepare for a meeting.

David: Oh, in dreams.

Corey: Yes.

David: Interesting.

Corey: Yes. Yeah, I was laying in bed. I had my eyes closed, and this pale blue light was coming through my eyes. I opened my eyes, and there's the Blue Sphere zig-zagging around.

David: Hmm. And you had no idea that this was about to happen.

Corey: No. Not this one. Yeah. I get up, and I get prepared for transport, and I indicate that I'm ready. And it took me to one of the big spheres out in space that I've described before.

And the moment I was deposited there, I could see the silhouette of Tear-Eir, and it looked like a human standing next to him, much shorter.

I looked up. My attention was drawn. I looked up, and I saw . . . The outside of the sphere acts kind of like a filter. It allows you . . . You can . . . Like if I was outside of the sphere, I wouldn't be able to see the other spheres in the solar system.

But while inside the sphere, through the walls, or the energetic walls, I could see other spheres. I could also see this crackling energy that is occurring in our solar system.

David: Was it coming from the sun?

Corey: Yes, it was crackling from the sun. And also the spheres were shimmering and heading away from the sun slowly. And they were headed towards Venus and Earth – the direction of Venus and Earth – but they were headed out in other directions too. But those are the ones that I could . . .

David: As an intuitive empath, did you get any psychic hit off of what you were seeing or what this represented?

Corey: I surmise, I believe, that, because of the increase in the energy coming out of the sun, that they were repositioning to help buffer these energies.

David: Hm. You see the spheres moving away, and you must have been curious about who is this silhouette next to Tear-Eir.

Corey: I really didn't have a chance to be curious yet. I saw them. They were a little bit of a ways away.

David: Okay.

Corey: And as I was looking up, peripherally I could see that they were moving towards me. So I looked back, and I looked at Tear-Eir, who greeted me, and then I looked at this other individual, and I had not seen their species before. They looked almost human.

So this individual introduces himself to me as Ambassador Mica.

David: And what did he look like exactly?

Corey: He was about 5'5" [165cm]. He was wearing a kind of a shimmering green robe and light-brown sandals. His head . . . You know how ours is kind of oval if you're looking at it from the top? His looked almost round.



David: Really?

Corey: His forehead and his head – it was much rounder. And his features were . . . It looked like kind of a mixture, but African. His nose was very African looking.

David: Okay.

Corey: And his cheekbones were almost Native American looking. His skin color was about the color that you would see in like Libya or Egypt today, except there was a very slight orange, orangeish hue or tint, to the skin.

David: Okay.

Corey: Yeah. And he had salt and pepper hair, mostly black. His eyes were brown and he . . . very compassionate look on his face and his eyes.



And he had wrinkles around mostly right here [**Corey** touches the side of his face near his ear], just these almost like chicken skin wrinkles right here. And he looked like an older individual.

David: Well, let me just ask you this. If this guy was walking down the street in Manhattan, would anybody notice him? Or would he be able to just walk around?

Corey: You would notice. You would notice.

David: Okay.

Corey: Yeah.

David: So he didn't quite look human, but he was close.

Corey: Right. And he told me that his people were in a star system that is within our local star cluster, that they are our cosmic cousins basically.

David: So just the closest neighboring stars.

Corey: Right.

David: And what else did he have to say? He's in our local star cluster, and what?

Corey: He stated that his people were very enamored with the people of Earth. They loved our cultures, our art, music, entertainment.

They had similar things on their planet, that they had been following our radio, television, Internet, since their inception.

David: Ha, ha. I don't know if that's good or bad.

Corey: Yeah. Not a good impression, but he spoke perfect English . . .

David: Really?

Corey: . . . with no discernible accent, which blew my mind. But apparently they have been studying us very closely for some time.

David: So they can watch television and watch movies from us, and they're interested in those?

Corey: Yes, very much so. He mentioned that, like I said, that they were cosmic cousins, and that they shared about 94% of the same genetics that we do, which was very interesting.

David: Is he analyzing electromagnetic waves, so you're getting like television shows and movies that have been broadcast over TV? Or do they also have access to the Internet and can watch a YouTube video or something like that?

Corey: Oh, he said that they'd been combing through our Internet, radio and television since their inceptions.

David: Hm. They obviously would have to have advanced capability to do that, because we don't have the ability to go to another planet. We don't know about other planets officially and see them.

Corey: Yeah, they're an advanced race. He's been in our solar system for some time as an ambassador.

David: Hm.

Corey: So I don't know where his embassy is.

David: Did you hear anything about his own culture? Like what are their people like? What's their history?

Corey: The only thing that he really touched on that was similar to that was that his people had been oppressed by the same beings that were oppressing us here on Earth, and that it has only been three generations that they had gotten out from under them - that they had won their freedom.

David: Wow!

Corey: And he indicated that their life span is a little over 300 revolutions around their star, which, I guess, if we would consider that a year, it hadn't been that long since they had gotten out from under whoever was controlling them.

David: Given the scope of what you've disclosed before, and some of the things that we've also heard from other insiders about the Draco having mind control that's exerted over the human population here, wouldn't it stand to reason that, if his people had overthrown the Draco, that they would have gone through some kind of massive quantum evolutionary leap after that, and that maybe he was just very fresh out of that?

Corey: That is a very, very good possibility. That didn't come up, but he did say that his people were very interested in coming here after we've broken through this control system, this, you know, reptilian, and through the elites and other species that are controlling us.

They were very interested in coming and helping us make the transition. He said that their problems were not as complicated as ours, but they were similar enough to where they would be a major help to us if we accepted their help.

But a lot of these different groups do expect us, after what happened with the reptilians and other groups – if we get our freedom, they don't expect us to be reaching out immediately.

David: Did you get a sense of how they were able to defeat the Draco? Was it through some kind of a war? Was it a consciousness shift? Was it an ascension? Exactly what happened to them?

Corey: I don't know, but he did indicate that, during the end of their conflict, that he had been in contact with Tear-Eir in almost the exact same manner that I am.

David: Really?

Corey: Yeah. He also indicated that his people had been on Earth as refugees during their . . . when they were under control of this group. Different groups had escaped and had come to Earth and had lived here for extended periods of time.

David: Did you get a sense of the time frame for this?

Corey: No. But he stated that that was pretty common, that there were many different refugees coming here at that time.

David: In your write-up, you also said that he told you that his people have very recently gone through a process similar to what we are undergoing.

Corey: Right.

David: And what we are undergoing, in “Law of One” terms, very much appears to be what they call “harvest”, or what I have been calling Ascension. So does it appear that that could be what he was referring to, that his people actually had ascended but that it had happened just very recently?

Corey: Yes. It could very well have meant that. He didn't specify, but he was also talking in context about . . . his people had recently been liberated. So it wasn't clear whether he was discussing the liberation of his planet, then an ascension, or both.

David: Was there any evidence of him actually having ascended abilities?

Corey: Not in that short meeting that we had. This was a very short greeting.

David: Did he have the ability to communicate telepathically?

Corey: Yes, as a matter of fact. I asked him why he was speaking to me in English and not communicating non-verbally, since communicating non-verbally is seen as more efficient, a more efficient way to communicate.

And he said that he was perfectly capable of communicating telepathically, but that he preferred to communicate with me in my own tongue. And I think maybe he wanted to practice his English or something.

David: Do you think that, with his surveying, and his people's surveying of our media, that they actually like us?

Corey: Well, he did indicate that we've got quite a lot to overcome, that his people were enamored with a lot of our culture, but they did not like our propensity for violence. And it's understood that a lot of the violence and the way that we're acting right now is controlled.

David: What do you mean controlled?

Corey: Well, mind control, propaganda, all the things that are going on Earth right now that's causing us not to be together, but at each other's throats.

David: Do you think that, if we were to talk to these people, that they would seem different than an average person on Earth in some way in their personality?

Corey: Yes. He was very matter of fact, but very calm and compassionate. He was introducing himself to me basically as a contemporary, that he had fulfilled a similar role with Tear-Eir on his planet.

He was wanting to meet me, and he wanted us to know – humanity to know – that we have family out there, that when all of this local control, and all the stuff that we're going through right now, once we're done with it, there is a wider community, a family out there that are looking forward to meeting us and helping us through this.

David: What do you feel, or what did he say, that they would have to offer us where this alliance would be beneficial to us?

Corey: Experience. Helping us overcome a lot of the emotional . . . just everything. You know, his people, once they got out from under the tyranny, they had to heal, and then grow, and then become a galactic species.

They were quarantined to their planet as well.

David: So they actually have a very similar story to us.

Corey: Very similar. Apparently, because of the wide range of races, ethnicities on our planet, and the different religions, that we've got quite a bit of a more complicated situation than they had.

David: You mentioned in the update that this meeting ended very abruptly.

Corey: It did.

David: So could you tell us exactly how that goes down?

Corey: He had just finished a comment when a Blue Sphere appeared behind Tear-Eir and Mica. It shot almost over the head of Mica, but close to the shoulder of Tear-Eir, right between them, came and stopped before me. And it was obviously time to go.

David: And you said you were a little shocked and somewhat disappointed because you were thinking you were going to get to talk to Tear-Eir more, but in this particular meeting, what happened?

Corey: Right. I was expecting to talk with Tear-Eir more. I wanted to talk about the cosmic scene I'd viewed as well. And I was taken back to my room.

David: What did it feel like to finally get brought up there again after such a long absence?

Corey: It was exciting. It was nice to know that things were going to continue. I was feeling very . . . I was feeling withdrawals, I guess you could say.

I wasn't getting the normal intel from the SSP. I wasn't getting as many face to faces with Tear-Eir. So it was encouraging.

David: How did you feel about the idea that this man had been contacted by the same being, Tear-Eir, the same way as you apparently, and that he had become an ambassador to an entirely different solar system? Did you think about yourself in those terms as well?

Corey: No, I didn't.

David: Okay.

Corey: I did think that it was very interesting that he had served in a similar role on his planet as I was doing right now.

David: Sure. All right, well that's all the time we have for in this episode. And there's a lot more to the story here on "[Cosmic Disclosure](#)". I'm your host, [David Wilcock](#), and I thank you for watching.

Cosmic Disclosure: The Return of Gonzales

Season 6, Episode 2

[David Wilcock](#): All right, welcome back to "[Cosmic Disclosure](#)". I'm your host, [David Wilcock](#). I've got **Corey Goode** here, and we are further going into the updates that he has to share with us. This is some of the most amazing stuff. So **Corey**, welcome back to the program.

Corey Goode: Thank you.

David: Let's go through now what happens next.

Corey: I was brought up into a Blue Sphere in one of these meetings, and Gonzales was there. And he'd been away for healing with the Mayan breakaway group, and he was a completely different person.

David: So let's walk through that a little bit. What happened to you when that contact started?

Corey: When the contact started, I had, as I had mentioned, seen Tear-Eir and a silhouette next to him. And it turns out that that person standing next to him was Gonzales, who I hadn't seen in some time.

David: Well, that must have been a concern, because he was pretty antagonistic towards you before.

Corey: Yeah. And to be honest, I felt a little anxiety when I saw him at first, but the look on his face was completely different. He didn't have the scowl. He didn't have the wrinkled forehead, the tensing

tendons in his jaws.

And the look in his eyes was totally different. He looked pleasant.

David: Hm. What was it like to see Gonzales in this newly transformed state? Did he have anything to say about the way that he had been before?

Corey: Yes. In the conversation when he was talking to me, he got a serious look on his face, and he apologized for his previous behavior.

He stated that he was triggered. He was in a really bad place. And I could tell – he was indicating that he really wanted to hear from me that I had forgiven him.

So I told him that, just like guys talk to each other, don't worry about it. It's in the past. Let's move forward. And he was visibly pleased that I wasn't going to hold on to any animosity towards him.

David: Good. What were some of the other things that he had to say at that point?

Corey: Well, he said that when he was going through the process with the Mayan group, that they had asked him if he wanted to know who he was, who he is, and who he would be. And he answered, “Yes” to the question, and he received information that allowed him to view everything with different eyes. He didn't see things the same anymore.

David: Did you get the sense that this had to do with past lives, reincarnation, things like that – soul destiny, soul mission?

Corey: Yes, I think it had to do with all that.

David: Okay. Did he also seem to have a vision of like his future – what would happen in the future?

Corey: Well, he did indicate that, talking about his past a little bit, that he had always been mission-oriented, was always wanting to work for the greater good. And he had joined the military to do that.

And he figured by being in the military and completing the mission in any way possible, he was being of service-to-others. And he stated that because of the rank he had and the way he was working up through the military, he ended up falling into a lower-density trap of ego.

David: Hm. So this question of identity is one that you've said before was presented to you.

Corey: Yes.

David: So did Gonzales have anything to say to you about that?

Corey: Yes. He told me . . . I had been presented two times . . . Tear-Eir asked me and Kaaree asked me, and I said, “No”, to both of them. And at the time, Kaaree kind of shook her head and said that stubbornness follows me through all of my incarnations.

David: Ha, ha, ha.

Corey: And after telling me that he had said, “Yes”, to that same question, he encouraged me to do the same in the future. And he went on a little bit talking about how he was going to remain with the Mayan group, that he was not going to be able to slide back into an old role, nor would he want to.

He was going to reside with them and be sort of like a delegate with them with other groups in the solar system.

David: Do you think that he went through some kind of Ascension experience? Or was this more of just like an emotional detox?

Corey: An emotional, psychological healing.

David: You mentioned in your update that there was something he said about the battle over Antarctica at this point. Did he just review what you already knew, or . . . ?

Corey: Yes, he gave me kind of a summary review of the information that I pretty much already knew.

David: Okay.

Corey: He did state that there might be another opportunity to have an operation that they had wanted to begin with when they wanted us to provide the intel.

David: Hm.

Corey: So, you know, a lot of the same information with a few new caveats.

David: You then mentioned in the update that he started to go into a lot of information regarding this idea of what **William Tompkins** has called “the solar sneeze” and what different Cabal groups and other groups think is going to happen.

Corey: Yes. Yeah. This conversation made me tighten up a little bit, get a little anxious. He started off by telling me that all of these groups that are going down to Antarctica are all looking to hide from this solar event.

David: Hm.

Corey: But of the occupants down there under the ice in Antarctica, they all had a different idea about what would happen when this “solar sneeze” occurred.

They all pretty much expected a coronal mass ejection that was the entire sun's corona mass ejecting.

David: Wow!

Corey: And they stated that most of the more scientific, pragmatic people, they expected a major blast wave to come from the sun that would knock out our electronics, electricity, and then behind that would come the mass ejection that would then hit the Earth.

Now, he said that there was quite a bit of a difference in what the different groups thought was going to occur when this blast hit the Earth.

Some of them expected us to lose all of our electricity grids, all of our electronics would be destroyed, and it would take a few decades to overcome it.

He also interjected that that event was expected to clear any artificial intelligence from our solar system and provide us an opportunity to disseminate all these new technologies to all of humanity at the same time.

David: Were there any other types of opinions about this solar event that were different than that?

Corey: Yes. Some of them expected it to come in, burn up the atmosphere, cause all kinds of earthquakes, volcanoes to go off, cause sort of like a nuclear winter situation. They also expected the sun to go dark for a number of days after this explosion.

David: As if all the light-generating surface is gone now and it has to rebuild or something?

Corey: If you just look at the dark spots in the sun, imagine the whole sun being a dark spot.

David: Wow! All across the board, it seems like we're hearing about something that the Greeks called "ekpyrosis". The word means "giant fire", and it's a giant fire from the sun. And all these ancient Greek and Roman philosophers all believed the sun was going to do this. It was considered common knowledge in the pre-Christian era that this was going to happen to us.

Corey: Right. And that's probably the . . . He said the most esoteric groups in these syndicates believe much like our community does, that this is going to be a kind of a spiritual or an Ascension type of event. And this is an event that those in our community look forward to, but one that these syndicates want to hide from or try to hide from.

David: If you go into the Zoroastrian tradition, the word they use for this is "Frashokereti", which actually translates as "making wonderful". And they say that the wicked are burned by this but that the just experience some sort of an Ascension. So that's a very interesting correlation there.

Corey: Right.

David: What happens next?

Corey: We were in the middle of a conversation, and I see a Blue Sphere come into the . . . well, basically it's not really a room, but come in to where we were.

David: And where were you? Where was this happening?

Corey: I was standing . . . When I had arrived, I had seen Tear-Eir and Gonzales standing next to each other. And when I was looking up at that cosmic scene, they had moved closer. And when they did, I noticed behind them were the two other Blue Avians and the Golden Triangle-Head being.

David: So you were inside one of the Spheres, and so you have that crisscrossing floor of geometric lines, and you're seeing the canopy of stars, etc.

Corey: Right.

David: So Gonzales gets picked up by a blue orb at this point or something?

Corey: Yes. Just . . . Right in the middle of the conversation, a blue orb comes in, and right before he indicates he's ready to go, he looks at Tear-Eir, and he said, "I think Tear-Eir wants to bend your ear until I get back."

And then 'fst', he was gone.

David: And you and him have just had a very poignant conversation that, as far as I'm concerned, it's really the core of the whole reason why I'm on this network. If this kind of an event that he was just describing is about to happen, there could be nothing more important than for us to know about this, to prepare for this, and to understand what it means for us and how we can harmonize with this change.

So what did Tear-Eir have to say to you after you've just had this big, heavy discussion?

Corey: Quite a lot, actually – quite a lot. He greeted me, and we started to discuss a little bit about what Gonzales and I had discussed about the solar event.

The sun he showed me pulsing, and then these huge blast waves coming off of it – energetic blast waves.

David: The sun was pulsing? Does that mean that the surface actually changed in size?

Corey: It was pulsing with energy. Energy was pulsing out away from it.

David: So maybe more just the energy comes out, not so much the size or the diameter of the sun changes.

Corey: Right. And the corona . . . There was like a second corona around the sun of electricity bolts all going out.

David: Oh, really? What color was that?

Corey: It was white.

David: Okay. And what were the pulses' colors?

Corey: White.

David: Interesting.

Corey: Yeah. And I also saw an image . . . He showed me an image of one of these waves hitting the Earth, and it wasn't what I expected. I expected a wave just to go 'phoof' through the Earth.

This wave came, and it hits the magnetic field of the Earth, and then it wraps around, and then it comes back on itself in the North and South Pole and then entered to the core of the Earth.

And then the energy emanated from the core of the Earth outward.

David: Outward in all directions?

Corey: In all directions through the surface.

David: Wow! What did this actually look like? Was it like white colors, white energy?

Corey: Yeah. The energy was white, but there was an interaction around the magnetic field that looked like aurora borealis but all the way around the Earth.

David: Oh, so that would be where the Hindus say that it's a rainbow-colored energy that comes off the sun, because they very clearly describe what they call "Samavartaka fire", and they say that when this happens that there are rainbow colors in the sky.

So that would be the aurora borealis you're describing.

Corey: Could be. And I was thinking . . .

David: It was all over the Earth, you said?

Corey: Yeah, the whole Earth.

David: Wow!

Corey: And I was thinking to myself, "How could these syndicate groups possibly believe that they could hide underground?"

David: Yeah, it sounds like the whole Earth is like a light sponge. It's just been soaked up and squeezed out with this whole new energy. So it doesn't matter where you are.

Corey: Right.

David: So this vision must have been very surprising to you. I mean, you're seeing something that probably would cause some people to just burst into tears because it's so profound. And it's our future. What was your experience as you're seeing all this?

Corey: My heart is beating fast. I'm breathing fast.

David: Wow!

Corey: Yeah.

David: So what happens next after you watch the energy go through the Earth?

Corey: Tear-Eir tells me that right now is a very pivotal time for our co-creative consciousness, that everyone on Earth, our co-creative consciousness, was deciding what type of an experience this would be, what type of temporal reality we would go into from this event.

And I wasn't really surprised that the mass consciousness was going to work in tandem with this event. I was surprised at how much it was, how incredibly important the mass consciousness is.

And he further stated that every single person on this planet is just as important as the other. There is no one that is any more special in this process, that we are all partaking in it.

And even some of the non-terrestrial groups that are trapped here are having an influence on it. Their mass consciousness . . . Their consciousness is having an influence on what is happening.

David: In the Law of One, they talk about a three-way split. They explain that there is a positive outcome for certain folks, there is a negative outcome for the negative path, and then a lot of people who are not able to ascend will recycle essentially – be brought to another planet where they continue.

So do you think this optimal temporal reality thing means that different people actually will experience one of those timelines depending on the choices they've made and what they've done?

Corey: That seems to be what was indicated.

David: Okay.

Corey: And all of this made me kind of think about the “Mandela Effect” that I’d been hearing so much about. And last time we were out here . . .

David: Could you define it again for those who don't know what it is?

Corey: It has to do with people experiencing different timelines, having different memories from the past. Some people having a memory that Mandela died in prison. Some people not having that memory. And then when he was let out of prison, there was a lot of confusion among people that had different memories.

David: Okay. And there's a variety of specific things, like “Interview with a Vampire”, “Interview with the Vampire”, “Berenstein Bears” or “Berenstain Bears”, this kind of stuff.

Corey: Right.

David: Okay. So you asked him about the Mandela Effect?

Corey: Well, I didn't have to. I was thinking about it, and he told me that this was a very real experience and that it would increase, . . .

David: Really?

Corey: . . . that we're experiencing a merging of temporal realities right now.

David: So it sounds like this . . . I can't imagine what it must have been like to be in this room, if you want to call it that, this Sphere, because I've never been able to experience any of the things that have happened to you.

I'm basically just like the audience. I'm having to try to interpret what you're seeing, have pictures in my mind without having been there.

I would have probably been in tears. This image of the sun giving off flashes of light, going into the Earth, transforming the Earth. This IS the Ascension. This is something that we have been expecting. It's a magnificent event. What was your feeling as you're seeing all this?

Corey: Anxiety.

David: Really? Why?

Corey: Well, it's quite a sight to behold. My heart was beating faster. I was breathing faster. And it didn't help my anxiety - the next thing that Tear-Eir communicated.

He communicated that if at this moment this event occurred, less than 300,000 people from the planet would be harvested or ascend.

David: And the word 'harvested' is a Law of One term.

Corey: Yes.

David: And was he using that term?

Corey: Yes, he was using that term.

David: Really? So that's very, very small. And tell us again what the criteria is for Ascension in the Law of One? It's very simple, right?

Corey: Right, to be 51% service-to-others.

David: And most people would naturally assume that they are.

Corey: Well, of course. Everyone thinks that they're at least close.

David: So where is the big stumbling block taking place? How could so many people not be ready when it would appear that all you have to do is just be nice?

Corey: Well, a lot of it goes back to the control system going on on the Earth, the mind control, the behavioral control.

David: But that's not our fault.

Corey: No.

David: Okay. But it's there, and it's affecting us.

Corey: Correct.

David: What is this control grid doing exactly that's making it so bad?

Corey: It's affecting our vibration to where we don't reach our full potential and we're easier to control. We're more apathetic.

And it was communicated that this control grid was being affected by these solar changes to a point to where either the non-terrestrials or the Cabal-type groups had to turn it to its maximum setting to have the desired effect.

But this also causes symptoms from the technology.

David: So wait a minute. You're saying that right now, this Draco mind control grid that we've already been discussing, that they've had to jack it up as high as it possibly can go in order to not lose control of the "slaves".

Corey: Correct.

David: So there's no higher that it can go than where it is right now.

Corey: That's what was communicated to me.

David: And what again is the spillover as they do this? What happens as a result of them jacking it up to 10 out of 10?

Corey: There are symptoms from this technology - people acting very erratically and bizarre and being totally apathetic, ineffective.

David: So you're saying that this is actually an energetic effect caused by this technology.

Corey: By the technology, and it's a cumulative effect with the energy coming from the sun, and it interfering with this technology being used against us.

David: So this seems really hard to believe. I mean, I remember, obviously, when they talk in Law of One about the second phase of our cycle on Earth that only 150 people on Earth were ready to ascend. So I guess in that sense, about 300,000 is better, but still, this is a big, big surprise to me. I did not expect the number would be that low.

What is this "optimum temporal reality" that he's talking about exactly?

Corey: The best-case scenario . . .

David: Okay.

Corey: . . . of, I guess, us going through . . . everyone on the planet or the majority of people on the planet that are service-to-others, going through, I guess, this Ascension-type event.

David: So there is a possibility that that number could still go way, way up.

Corey: Right, because right now, the temporal realities are not set. We are the deciding factor. How we respond to what's going on right now, our mass consciousness is a major factor in which temporal reality we end up on.

David: So how do we know which temporal reality we are going to be on as this goes forward?

Corey: I asked Tear-Eir that. I said, how will we know if we have chosen the optimal temporal reality? And he replied that **David** and myself . . . if the world was shaken around us, that we would know that we had chosen an other-than-optimal reality.

And I thought to myself, “Well, what are the chances of **David** in California, me in Texas, feeling the same earthquake? Because I assumed it was an earthquake.

So I wasn't quite sure what that referred to.

David: A pole shift would be a worldwide earthquake and worldwide volcanic activity and tsunamis and super storms all happening at once. So that's apparently one reality. But he's saying that if this happens to you and me, that in that moment we would know that . . . that what?

Corey: We had chosen an other-than-optimal temporal reality.

David: Humanity as a whole?

Corey: Right.

David: But then you and I would actually be experiencing a cataclysm.

Corey: It's hard to know fully what he was saying. He was just saying the world would be shaken around us, and then we would understand what had occurred, that we were not going to be happy about it.

David: Let's just be clear for people watching this because this is very serious stuff we're talking about now, and we don't want people having nightmares, and we don't want them writing in saying they've lost their faith in us and all this stuff.

It's been said, to me at least, that even if that timeline took place that we get pulled out and you're not going to experience a physical death unless your karma invited that. Would you agree with that?

Corey: Yes. Overall, I think that this was some sort of a cosmic wake-up call for the planet . . .

David: Right.

Corey: . . . that we need to be working right now on working through our karma, and we need to put as much effort as we can into being service-to-others.

David: Whew! If the numbers are that low, then let's hope that there are things that can be done that would change that.

Corey: Oh, obviously there are.

David: Okay.

Corey: He was saying if it were to occur right now, that's the way it would turn out. But we are still making a choice as a mass consciousness being on which of these temporal realities that we're going to choose to experience.

David: Well, when I think of Gaia, I think of it as the Disclosure Network. If Disclosure is the purpose of this network and what we're doing here, why we're doing this network is to get the word out, does that have an effect on the outcome?

Corey: Absolutely. A Disclosure that's a worldwide Disclosure is going to change the consciousness of everyone on the planet. And that's going to boost us in the right direction.

David: Do you think that maybe many of the people who are so distraught right now, that are always writing negative comments on the Internet, and the economy is so bad, and they have a sense of

hopelessness about the future, do you think that if there was this sort of “if you throw up you'll feel better” kind of thing, that those people's opinions might start to change? They might not be so angry anymore? Is that kind of what we're talking about?

Corey: Yeah. If everyone receives the truth, then they can move on and start working on these self-improvement aspects.

David: So did you get the sense that you and I were steered into this network and being part of this disclosure initiative here for a reason, that this is part of what could turn the tide?

Corey: Obviously, yeah.

David: Okay. So in some way as people learn the truth, their attitude and their consciousness shifts, and that in turn affects the whole planet.

Corey: Indeed. And I had several more questions along those lines when I saw the Blue Sphere come back in, and it deposited Gonzales next to the three beings that I mentioned before – the two Avians and the Golden Triangle-Head being.

David: Okay.

Corey: That occurred as we were finishing up our communication, Tear-Eir and I. And then they glided closer.

David: So what happens at that point when they glide back to you?

Corey: Gonzales walks over, and he makes a smart remark like he normally does. And he says, “I hope you didn't miss me too much.”

David: Ha, ha, ha.

Corey: And it was nice to see that he still had his, you know, same sense of humor.

David: Right. So the Mayans had not taken away his personality.

Corey: Correct. And he put his hand on my shoulder and guided me away from the group and started to finish our discussion.

David: And what did he tell you at this point?

Corey: He wanted to finish talking about what had occurred down in Antarctica. And he repeated the same stuff. It was nothing new.

David: Okay.

Corey: But then something popped out that he had never said before. He said, “In that area where you did the reconnaissance and saw all of the ancient structures just strewn about, . . .” not far from there they had found an ancient burial ground.

And in this ancient burial ground, they were finding the remains of beings with elongated skulls . . .

David: Oh, man!

Corey: . . . and wide hips, smaller rib cages. And that was obviously something I had heard before.

Furthermore, he told me that . . .

David: That's crazy.

Corey: Yeah. He told me that they had found preserved remains of these beings that looks like they were flash frozen in the ice.

David: Now, some of these folks appear to be giants with elongated skulls. Did these people have a normal human height?

Corey: They're normal human height.

David: And what was the data range again of how old they were?

Corey: 18 to 60,000 years. That was in the graves.

David: Wow!

Corey: Now, they found remains of prehistoric animals and some of these beings that were flash frozen under the ice . . .

David: In Antarctica.

Corey: In Antarctica. And some of the big blocks were lifted many feet in the air off the ground and were flash frozen. It was like there was a giant tsunami that somehow turned turned to ice in the middle of . . .

David: The blocks were from pyramids or megalithic structures?

Corey: From megalithic structures.

David: And it froze so fast that they were literally levitated in the ice?

Corey: Well, it sounds to me like some water hit them, or something hit them, and destroyed them, and while they were in the middle of the air, somehow they got frozen in the ice there. Whatever happened, happened very quickly,

David: How many of these bodies were found in this excavation?

Corey: I was not told.

David: But it was sizable enough that they were seeing this as a major new find?

Corey: Yes. This was a civilization that had some sort of catastrophic event occur very quickly, and they had no time to react.

David: So what else did Gonzales have to tell you when you had this second meeting with him?

Corey: He also mentioned that during his time with the Anshar, he had seen some peculiar things. It was before he had worn out his welcome there. They were kind of complaining because he was always going around doing recon of everything down there.

David: Right.

Corey: And during one of these recon missions of his, or a couple of times, he saw two priests walking down a corridor and then walking through like a cave wall. And he followed, and he couldn't go through the wall.

And it was the third time that he saw them that he . . . Each time he was looking for a way to see in. And after he looked around quite a bit, there was some crack or fissure in the wall that he could look

through. And he saw these two priests, Anshar priests, talking to a number of giants of different heights.

David: Giant humans?

Corey: Giant humans. And one of them was sitting on a big boulder, had his forehead in his hand, and was groaning while communicating with them. And I didn't get any further information other than that.

It was shortly after that he was asked to leave.

David: The giant appeared distressed. Do you have any speculation as to why the giant was distressed?

Corey: He said that he thought that either they were prisoners or that they were refugees and they just were very unhappy. He really didn't know. And I don't know.

David: All right, so was there anything else of significance that Gonzales told you at this point?

Corey: Yeah. After this, he mentioned a few things just in passing. He mentioned a few things about what was going on on the surface of the Earth.

He said that the syndicate groups and the Earth Alliance groups were getting nowhere in their negotiations. He stated that these syndicate groups were insisting that either everyone of them be pardoned or none of them be pardoned.

They didn't want any of the lower people, or people that worked for them unwittingly, to be pardoned unless they were pardoned, too.

David: Yeah, but if one person steps on a bug and somebody else is a mass murderer, how can you try to hold everybody equally accountable?

Corey: Well, that's where they are in the negotiations.

David: Wow!

Corey: He also discussed a few small things, like the military intelligence groups had been tracking DH – Department of Homeland Security - assets that were quietly deploying throughout the United States, getting prepared for social unrest.

Military intelligence had heard that the DHS was willing to put down any public rising [uprising] with violence – any uprising with violence.

David: So are you saying that these assets are in place because of an anticipated Alliance move against the Cabal in America or something like that?

Corey: It wasn't specific. They were preparing for some sort of public uprising, and the military intelligence groups had begun putting military assets, like special forces operators, in position to shadow these groups, having them get jobs in a certain area and try to blend in while observing what was going on and prevent them from carrying out whatever they were going to do.

David: Hm.

Corey: He also mentioned that it was a concern that they didn't . . . He didn't think that the syndicates were going to allow Trump to become president even if “they had to stab him on Inauguration Day,” is what he said.

David: Really? Well, a lot of people who are at least in left-leaning media, they think that Trump is a racist and a misogynist and this and that and the other. But are you saying that they continue to believe that he is actually not a Cabal member and that he's actually going to do something positive for us if he were to be elected?

Corey: Well, they believe that he is not a Cabal stooge, and that he's not very controllable.

David: Ah.

Corey: And that if he has that position, if he gets that position, it's going to be very bad for these syndicates.

David: Because they like a president that's basically a marionette for them.

Corey: It's their last bastion of control. Gonzales also stated that during these negotiations, they had insisted that there be no Full Disclosure, that they wanted a controlled disclosure over a 100-year period, that as I told you in the past, they think it's irresponsible, that it was going to cause socioeconomic collapse, that countries victimized by the Cabal were going to want to strike back, that it was not going to be good for humanity when it's not going to be good for the Cabal.

David: So they're still pushing for this partial disclosure.

Corey: Yes. And a lot of the Alliance agrees with it.

David: But I thought you had told me earlier this year in talking with Gonzales that they had concluded that partial disclosure was impossible.

Corey: Well, the SSP Alliance has.

David: Oh. But maybe the Earth Alliance group still think that they could pull it off.

Corey: Correct. They also are opposed to any document dumps. They think that would be irresponsible as well. It's already been figured out that any type of data dumps are going to be done in spurts, because the Cabal has . . . They're ready for it.

They're ready to flip the kill switch on the Internet and do whatever else it takes to mitigate the damage of the information being released. So they're going to have to release it a little bit at a time.

David: So is there anything else at this point that Gonzales has to say to you in this meeting?

Corey: Well, he was also mentioning that these syndicate groups were happy with the fact that they were able to cause racial disharmony and riots in certain areas. They expected them to use that as a further wedge with our society in the future.

David: That makes sense.

Corey: And then they went over some of the old threats that we've covered before about the super volcanoes under the ocean, that they're threatening to blow up and cause an extinction-level event.

They're threatening to, as I said, shut down the Internet. There are a lot of threats, a lot of brinksmanship that the syndicate groups are making.

David: Well, but as we've discussed, it definitely appears that they're not going to be authorized to do that stuff because humanity's free will collectively is not activating that to happen. Would you agree with that?

Corey: Yes. All of the attempts of the syndicate groups to start World War III or to cause big problems like this have been unsuccessful.

David: Well, this is the first time that you've really had access to the SSP Alliance since this whole stuff with the Wrangler happened. Even though Gonzales isn't really in it anymore, he said he was in contact with them. So did the Alliance have anything to say to you through Gonzales?

Corey: Well, they were wanting to offer me some sort of an olive branch and also were saying that they were going to have this Wrangler character apologize to me publicly.

David: Publicly where?

Corey: In front of all of his peers.

David: Oh, wow!

Corey: I wasn't really interested in seeing that guy again, so that one really didn't pique my interest at all. But I did want to know more about the olive branch, which Gonzales gave me the information. And it was basically the same offer they had made me before through the Wrangler, but in a negative way.

David: Well, you've mentioned before that they have some pretty advanced healing technology up there. Did you ever ask them if they would help you with any of that stuff?

Corey: Well, yeah. That had been dangled in front of my eyes a couple of times. And he stated that if they still had access to the LOC [Lunar Operation Command] before the outing of their people, they would make that available to me, but they would make available to me what they had, which was some healing technologies.

David: Now, the Wrangler had offered you some kind of intelligence job working for the Alliance, where it seems that you would no longer be able to talk to me or anybody on this show about much of what was going on, but that you would have taken over what Gonzales was doing, which sounds like he's not too happy about that now that he's actually been healed.

Corey: It was the exact same offer that the Wrangler gave me.

David: They brought it back again.

Corey: They brought it back again but put a positive spin on it. It was the exact same setup. And I politely declined.

David: Well, it seems as if your role is to share information. And obviously, if you did that, then all that information would be cut off.

Corey: I don't want to be under the control of a group of sociopaths, either.

David: So how did this particular meeting with Gonzales end?

Corey: It ended somewhat abruptly again. This time, Spheres came in for both of us. And we were both taken away. And I ended up at home. And shortly after that, Kaaree contacted me and told me to prepare for a trip to Venus - the one that I was turned away from the last time.

David: Oh, wow!

Corey: So I started meditating and making sure that I had the right energy when I went in so I didn't get turned away like Gonzales did.

David: Right. And that's what we're going to be getting into in the next episode here on "[Cosmic Disclosure](#)". This is a really amazing journey, and we'll see you next time. Thanks for watching.

Cosmic Disclosure: Encounters with Ancient Sentinels

Season 6, Episode 3

David Wilcock: All right, welcome back to "[Cosmic Disclosure](#)". I'm your host, **David Wilcock**. We're here with **Corey Goode**. **Corey**, welcome back to the show.

Corey Goode: Thank you.

David: What happens next in our big story here?

Corey: Well, next I finally get to repeat my trip to Venus, the one that I'd went on before, but we were unable to complete the trip because there was some sort of scheduling conflict with another group that was visiting Venus.

David: Well, you also seem to have kind of like a confrontation, right? There's these ships that are kind of orbiting around Venus, and I had the sense that they did not want you getting any closer, and it was almost like a military standoff or something.



Corey: Well, there was one that was blocking us, but the communication was going on between Kaaree and them, I presume.

She sat there silently and then told me that we would need to return.

David: So you mentioned in your update [**Corey Goode** Intel Update Part 2] that August 3 [2016] you were told to prepare for this, but this was just sort of to get you ready for it.

Corey: Right.

David: So how did you get prepared for this?

Corey: I was doing my best to meditate and get in the right frame of mind, because Gonzales had been turned away.

David: So did Kaaree give you any specific instruction as to how to prepare for this trip?

Corey: No, she just told me to prepare myself, that it was about to occur.

David: And you knew that Gonzales had been taken away, and what did the Sentinel tell Gonzales at the time about why he couldn't go in?

Corey: That he lacked humility.

David: Lacked humility?

Corey: [Nods.]

David: When did you actually get the opportunity to visit Venus? When did that happen?

Corey: About a week later. I was laying in bed, and bright flash, just like the first time I was transported down to the Anshar domain. And after the flash, after my eyes had cleared, I was standing next to Kaaree and two other Anshar in kind of like a foyer that went into the area where they housed their craft, into their hangar.

David: So this is still in the Inner Earth at this point.

Corey: Yes.

David: Okay.

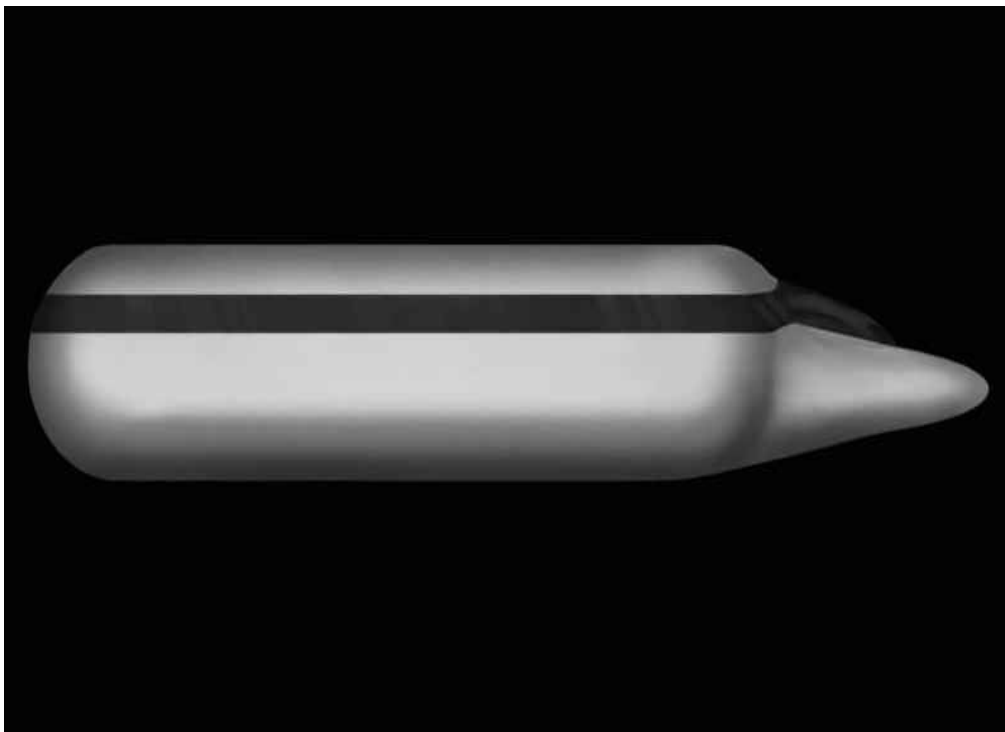

Corey: So they guided me inside. We went inside one of the Anshar buses, the one that had the blue seats, and a blue, swirling light opened above us longways like this. We went straight up through it. And as we came up through it, we were now above the ocean and another blue, swirling light below us.

David: Interesting.

Corey: The craft didn't go longways. [**Corey** show the nose pointing upwards.] It was still sideways, flat, like I mean parallel to the ground. It shot straight up in the air and out into space through this one little area that they are cleared to punch in and out of the atmosphere through.

David: Huh.

Corey: So once we had left, it was uneventful. We didn't have any problems coming or going like we did the one time.

David: Nobody was shooting at you, in other words. Ha, ha, ha.

Corey: Right. But that was in the middle of whatever conflict was going on at the South Pole.

David: Right.

Corey: And this time, she took us to Venus. They took us to Venus. And this time the trip was like 10 minutes. It was much quicker than the last one.

David: Huh.

Corey: And we stopped at just about the same position we did before, and we paused there for a little bit, and she was sitting there like she was doing something in her mind. And then she said, "Okay, we're cleared. Are you ready?"

And I said, "Yeah, about as ready as I'm going to be."

David: Were there any craft in the atmosphere at that time?

Corey: No. The only thing that was showing up on the Anshar technology, it looked like an asteroid and debris with it that was far out in Venus' atmosphere, caught in its gravitational field.

David: Interesting. Okay.

Corey: So once I indicated that I was ready, we headed towards Venus at a super high rate of speed, punching through the thick clouds. I barely could perceive yellowish color, we went through them so fast.

And then we stopped about 1,000 feet [305 meters] above the ground, and I was looking around, and I saw this terrain that looked like it had been eroded by lots of wind and rain, sort of like you would see in Earth. They looked like they used to be mountains going up that had eroded away, and they looked almost like people. It looked almost carved by an intelligent hand.

So I was noticing that, when all of a sudden the ceiling and the floor went transparent, just as it had done in our Antarctic reconnaissance flight.

David: Right.



Corey: And I looked down, and I could see the big, giant, H-shaped building sitting inside this crater.

David: Hmm.

Corey: And we were close enough to it where I could see there was a line that went across . . . Like here was the H, a line went all the way across it that divided it into basically two buildings.

David: Hm.

Corey: And we were sitting there, and I saw down at the bottom a flash that we could see through the technology. Once that occurred, we went down at a very high rate of speed.



David: Are you feeling acceleration?

Corey: No. I couldn't feel any inertia, but my mind was, I guess, playing tricks on me, and I felt that falling feeling you get in your stomach.

David: Hm.

Corey: But I wasn't feeling any inertia. And we stopped at the bottom, and the sheer size of these two buildings that were . . . They weren't connected. There's nothing I could compare them to.

David: So these buildings you're saying are colossal in size.

Corey: Yeah, bigger than anything . . . There's nothing I could compare them to, man-made-wise.

David: Would you say they were miles in height?

Corey: Miles.

David: Really?

Corey: It was HUGE!

David: Did they have a sculpted appearance? Did they look like they were made out of something . . .

Corey: Flat.

David: So it was a flat, kind of sharp-edged structure.

Corey: Right. Right.

David: How neat and finished did it look? Did it look broken down and degraded?

Corey: Yeah, it looked ancient.

David: Okay. Wow!

Corey: And weathered. We shot down to the bottom where we saw the flash, and when I was looking up, I could barely see the top of the building.

David: Wow!

Corey: It was huge. We flew inside this cavern down at the bottom, and we landed in the area where Gonzales had gone before. It was kind of like a grotto area that wasn't extremely large. The walls were glistening as if there was, I don't know, some sort of crystalline nature to 'em.



David: Hm.

Corey: And there were two things similar to obelisks on either side of . . . Okay, there was a door here, a huge door going into the larger part of the cavern. The Anshar craft was here, and then there was an obelisk thing on each side of the entrance to the door, but not exactly by the entrance.

And they had Hs on them, kind of like a totem pole manner going up. And it got smaller and smaller.

David: Okay, got it.

Corey: So once I looked around and I noticed that, and I was looking through the opening, and I could see one little piece of the structure that we were going to go to. And it looked like tinted glass.



David: Were the obelisks that you saw also glass-looking?

Corey: Stone.

David: Stone. Okay.

Corey: And they looked newer. They didn't look real old, but maybe it's because they were protected.

David: Was the H like carved inside the stone, like carved in? Or was it embossed and it came out?

Corey: It was carved in.

David: Okay.

Corey: And then – boom! - with no warning, this 14-foot-tall white being appears.

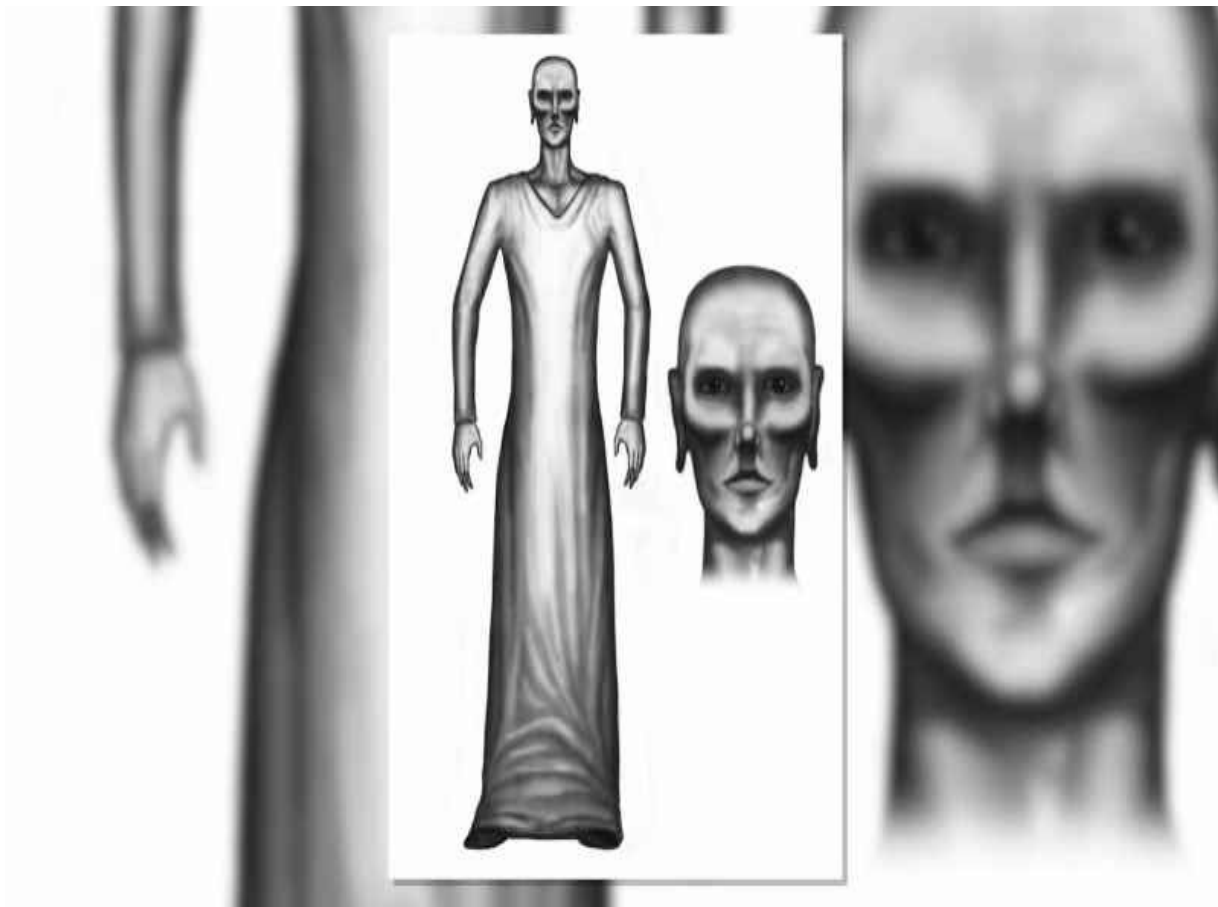

And it's wearing clothing that looks like shiny, white plastic.

David: Wow!

Corey: Yeah. And the most interesting thing was that they had black eyes, but they had this nose . . . The bridge of their nose went down, and then it looked like it kind of turned up. Like part of the nose

was shooting down, and then this part right here [the tip of the nose] was going up.
It is very odd looking.



David: When you see black eyes, you mean did they have whites of their eyes, or was it totally black?
The iris was black?

Corey: The iris.

David: Black.

Corey: Right.

David: So they have a very unusual nose.

Corey: Right. Chiseled bone structure, real straight lines in the cheeks, and white hair, or what would pass for hair.



And I was a little shocked when it appeared, but it didn't communicate. It just looked at us and then did its head like this [**Corey** moves his head as if motioning for the group to follow him to the left] and turned and went through the passageway.

David: Did you get the sense that this was a living being or some sort of bio-hologram or something?

Corey: It seemed to be some sort of intelligent hologram.

David: Okay. So it turns it's head and leads you into where?

Corey: Into the larger cavern where this structure was that I only saw a piece of.

David: So when you see the structure now, what are you actually seeing?

Corey: Well, as I walk through and the structures seem to grow as I'm walking in, I look in, and it's similar to a pyramid, except the base was probably . . . you know, it wasn't square. The corners curved into each other.

David: So they were concave.

Corey: Right. And on each point, each corner, there was an area that was open that went up really high and then went back down as it curved around. And it went up about 300 feet. It was really tall.



David: And you said it was like a pyramid?

Corey: Yes. Except it was like a pyramid and a tower. It was like the Eiffel Tower, but it was shaped like a pyramid.

David: More like a steeper slope angle like this, like the Russian pyramids were.

Corey: Yes. And it was over 1,000 feet tall.

David: Wow!

Corey: And it went almost to the top of the cavern.

David: How was its level of preservation? Did it look very ancient and damaged?

Corey: It was brand new. Brand new.

David: Brand new.

Corey: Yeah.

David: And the room that it was in, did it have stone walls?

Corey: Yes. It was a giant cavern.

David: Wow! Okay. So this must have been just a stunning thing to see. I mean, you've obviously never seen anything like that before.

Corey: You almost fall over backwards. You walk in and you're just, I mean, you're looking up, and you almost fall over backwards.

David: Wow!

Corey: So we followed this being that the Anshar call the Sentinel into one of the corners where it arches.

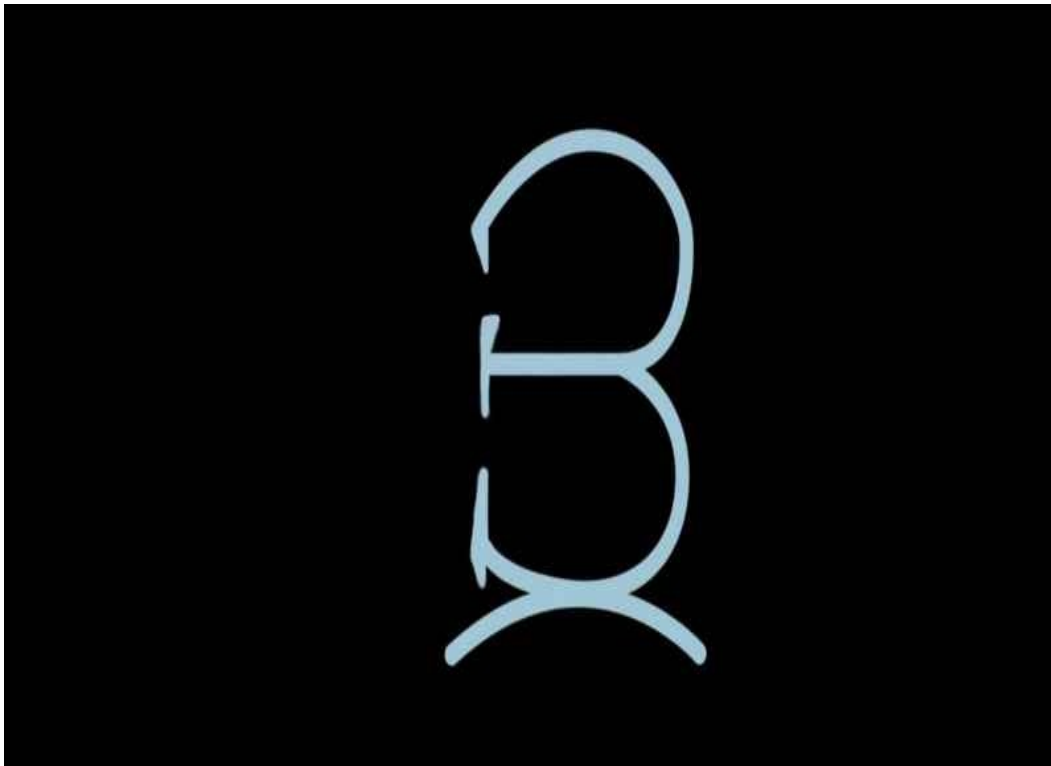

David: Okay.

Corey: We walk in a ways, and then we all turn and look at the wall of one of the corner areas.

David: Okay.

Corey: And there is a big symbol that Gonzales had described. It looked like a backwards E that was like a G at the bottom that was flattened at the bottom.

And there are other symbols on the other three corners that I couldn't really make out.

And all of a sudden, the tinted glass went clear, and all of these other different types of symbols started appearing, and then they started moving. They were moving this way [to the left], they were moving that way [to the right], catty corner in every direction. It was just moving all around.

And they were like pulsing all the different colors of the spectrum.



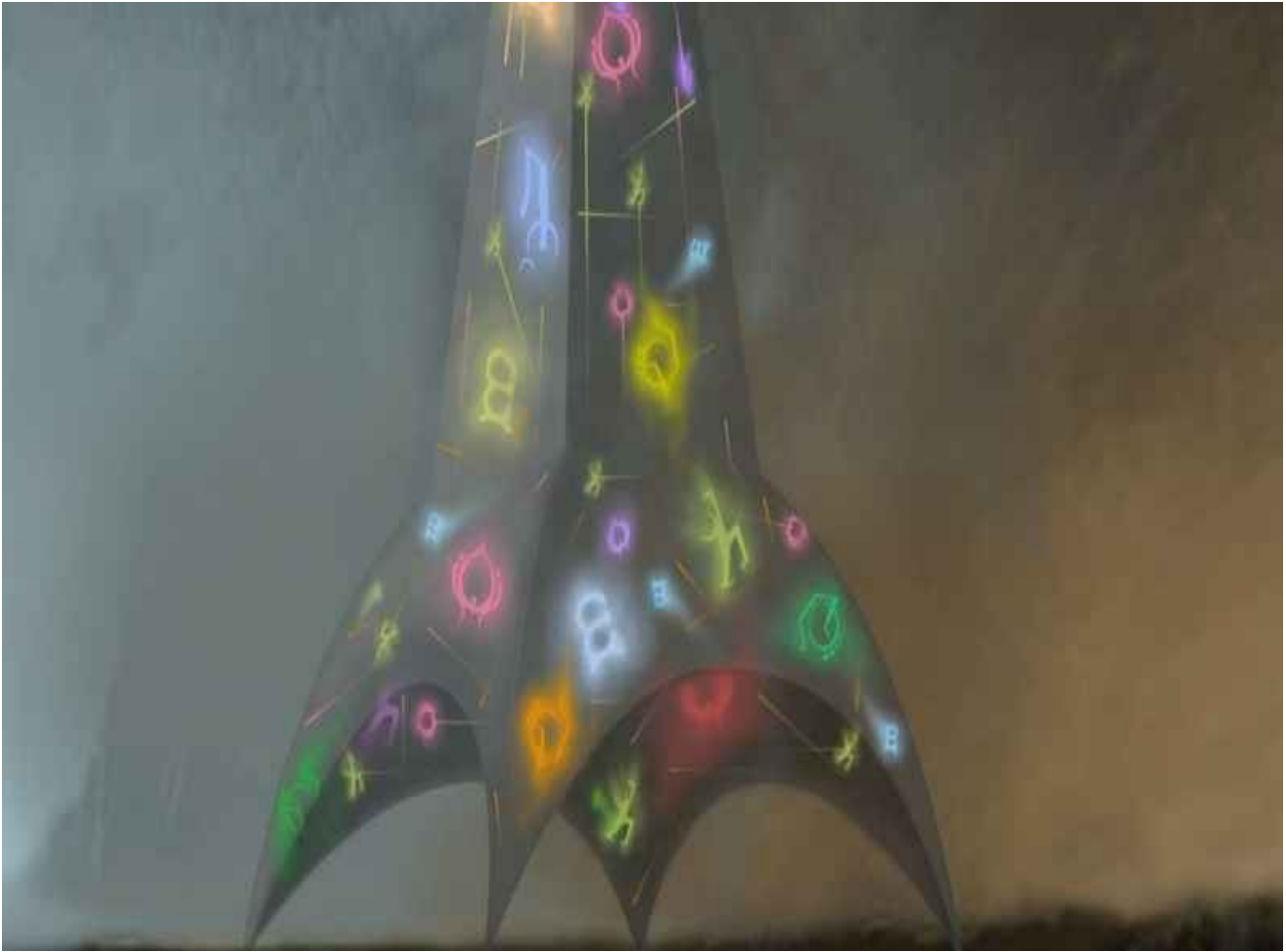

David: Wow!

Corey: And I was hearing tones as well – a full range of tones along the octave scale.

I was like, okay. And I looked over at Kaaree, and she put her skinny little finger up and said, “Watch”.

David: It's like you're reading other people's mail. Ha, ha.

Corey: Oh, I didn't know what was going on.

David: Ha, ha, ha, yeah.

Corey: So I looked, and I'm watching, and all of this is occurring, and I start asking her questions, and she was like, “Just watch. Pay attention!”

David: Hm.

Corey: So I paid attention and was watching, but this Sentinel communicated with me, and it was more powerful than the incident with the White Draco, where it reached in violently and just took over.



I could feel the communication in all of my body at the same time.

David: Wow!

Corey: And it simply asked me, “Would you like to know who you were, who you are, and who you will be?” The question I’ve been asked before.

David: Ha, ha, ha. Same question that you said Gonzales had been asked, and he said, “Yes.”

Corey: Right. Well, I felt compelled . . . I said, “No.” And I saw a movement out of the corner of my eye, and Kaaree went like this [**Corey** wraps his hands around himself] and looked down and had a big ol’ smile on her face. She wasn’t surprised.

David: Why do you feel so emphatically that you shouldn’t answer “Yes” to this question?

Corey: The feeling I got when it was explained to me that it would change the nature of all my personal relationships. I just . . . I think of my children and my family.

David: So if you get this kind of download, if you get this recall, why would that be a bad thing for your family or your kids?

Corey: I don't know. It's just a feeling I got.

David: So you just maybe have some sort of anxiety about something that might change who you are in such a fundamental way.

Corey: Or maybe deep down I know something that I don't know consciously.

David: Okay. So let's walk through what happens after you say, "No".

Corey: The being disappears, all of the symbols had stopped. And the only symbols that remained were the ones I described before.

David: Which was the E with the G on the bottom, the backwards E?

Corey: Right. And while the symbols were flying all over the place, one of the questions I asked Kaaree was, "Is this math?"

And before she told me to turn and look again, she was like, "This is a mathematical language of the ancients."

David: Hm.

Corey: And it was over. The being disappeared without saying a word. And the structure went tinted again.

And so we started to walk out and I started asking Kaaree, "What just happened?" You know, I was thinking to myself, "Is that it?"

I was expecting some big tour of Ancient Builder Race ruins, . . .

David: Sure.

Corey: . . . and I was disappointed. Let down. And she told me that information had been imparted to me and received from me.

David: So maybe what you saw was almost like picking up the phone on an old dial-up modem, 'eEEEE', that kind of stuff. And somehow you could descramble that data, but what you were seeing maybe was not the solution. It was just the code or something like that.

Corey: Well, whatever was imparted to me, I felt like some giant zip file had been put on my hard drive, and I could feel it taking up space, but I didn't have the password. I didn't have access to the information.

And I was telling her, “This doesn't make sense. Why would I have information like this and not have access to it?”

And she said, “It will make sense in the near future.”

David: Do you think that maybe some of the answers to that question are in there as well, possibly, about who you were, who you are, who you will be?

Corey: The feeling I got is that if I would have answered “Yes” to that question, I probably would have had access to it then.

David: Okay.

Corey: So we walked back to the Anshar craft. The two pilots were back inside the craft. They had come out with us and were standing at the door of the cavern.

When we came back, they were already in the craft ready to go.

David: Were they all wearing the same ceremonial robes that they had the first time?

Corey: No. They were wearing the blue jumpsuits.

David: Okay.

Corey: She indicated that we were now going to go to the Saturn station.

David: Right.

Corey: So we got in the Anshar vessel and took off at a high rate of speed out the way we came. And within moments, we stopped, and I saw Saturn, about the size of a silver dollar.

And I could see like some white dots around it. I couldn't make out what they were. They were probably the moons or something.

David: Okay.

Corey: So we're sitting there, and we pause for a moment, and then we head into one of those temporal anomaly spaces just like was by Jupiter that we would travel in to go to the Super Federation meetings .

..

David: Okay.



Corey: . . . where you had to go in and come out the same way. So we go into this temporal bubble, and again, all the stars, everything disappears. It's pitch black. And all we see is the station, looks about this

big. [**Corey** hold fingers about six inches (15cm) apart.] It's rounded on this side, and it's out long and has something like this at the end and in the long areas where all the vessels of the Super Federation would dock. And then they would walk in and go into the larger, round area where you hold the meetings.

Well, there were no craft at all. It looked desolate.

David: But how similar was this to the Super Federation meeting space?

Corey: Exact copy.

David: Really?

Corey: It was an exact copy.

David: But nobody's there.

Corey: Nobody's there.



David: Could your ship check for life signs or anything?

Corey: Yes. There was nothing.

David: Okay.

Corey: So we docked and got out, walked along the corridors. Real tall ceilings, somewhat narrow walls, but tall ceilings, because a lot of the beings are different sizes than us that would use these facilities.

David: Right.

Corey: So we walked down the long corridor. We came out in the foyer, exactly like the big decorative foyer at the other station, the Jupiter station. And there was no one there.

I've never seen one of these places completely desolate.

David: Interesting.

Corey: We walked into the main hallway, and it didn't have all the seats in it, the horseshoe-shaped areas where people sat. It was just open floor.

David: Hm.

Corey: So we walk inside there, and there appears a Sentinel again.

David: The same guy as before?

Corey: It looked exactly the same.

David: Wow!

Corey: So without saying a word, it reached into my mind and immediately started showing me all these scenes. I would see kind of like . . . It would be sort of like seeing movie clips. But some of them were just like maybe less than a second. Some of them lasted like four or five seconds.

But they were just “phffffff- phffff-phffff” flying around like crazy.

David: Scenes of what exactly?

Corey: Well, I saw my life, and I started seeing my memories going all the way back to the earliest point in my childhood.

David: So did it start from where you are now and then count backwards?

Corey: Yes. Yeah. And I was seeing just little, I mean, I saw my dad in this old blue rocking chair that we had when I was a kid. That's one of the ones that stuck in my head. But it was just going by so fast.

David: Did these events seem to have emotional significance or poignancy for you? Were they like significant in any way?

Corey: No.

David: It's just a big flash.

Corey: Yeah. And I was just kind of, you know, they were strobing. I was kind of picking one and two out here and there.

And then we started going through memories that were not mine – scenes of past times. It was just very undescript kind of things, but they were familiar.

David: Did you notice what would appear to be like medieval buildings or something?

Corey: No. Inside buildings. Like inside dwellings, like seeing people and real quick flashes. It wasn't something that you could grab and look at and look at all the detail – all of the picture.

David: Hm.

Corey: Once we got through that I started seeing these wild cosmic scenes of out in space of these giant physical, tangible spheres that looked extremely large like the size of a moon that were discharging these huge bolts of electricity and destroying large vessels that were coming into the solar system, destroying other giant, large spheres that were coming in that looked technological.

There were like hundreds of these different scenes playing through.

David: Okay. Let's just stop for a second. In the second episode of “Deep Space” here on Gaia, it talks about mysteries of the solar system and it goes into Iapetus [moon of Saturn], and the idea that the

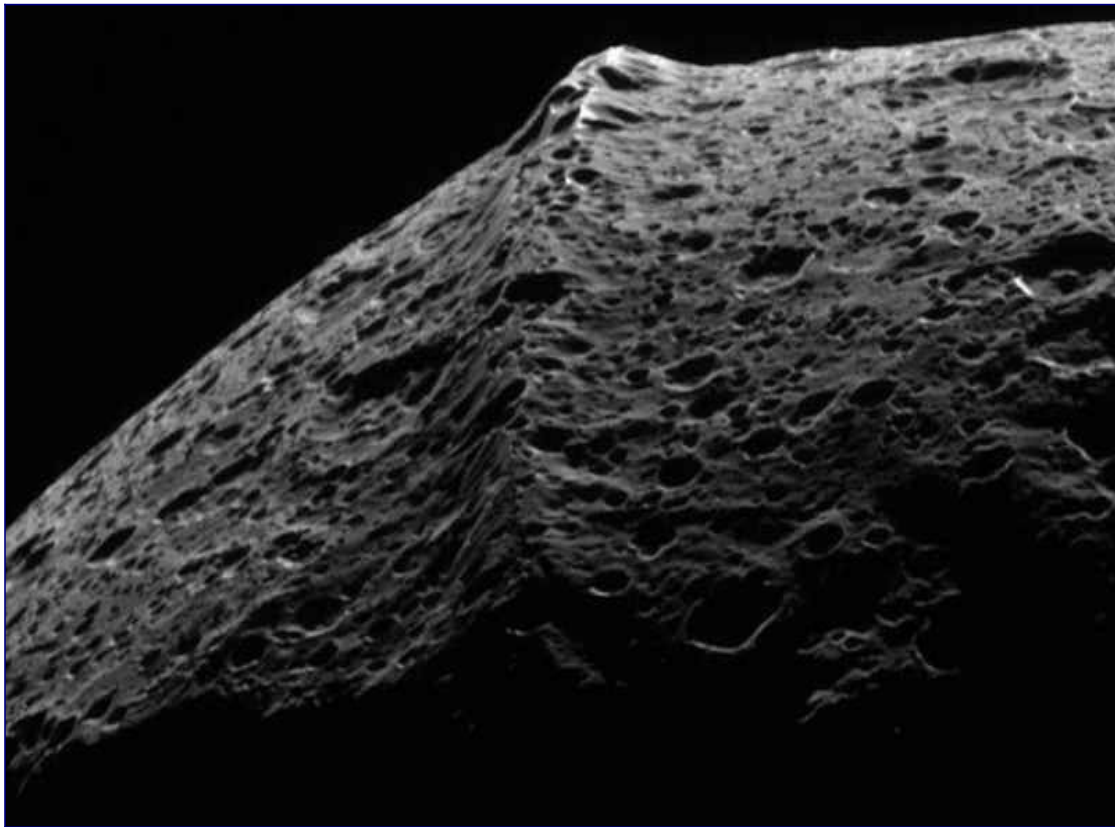
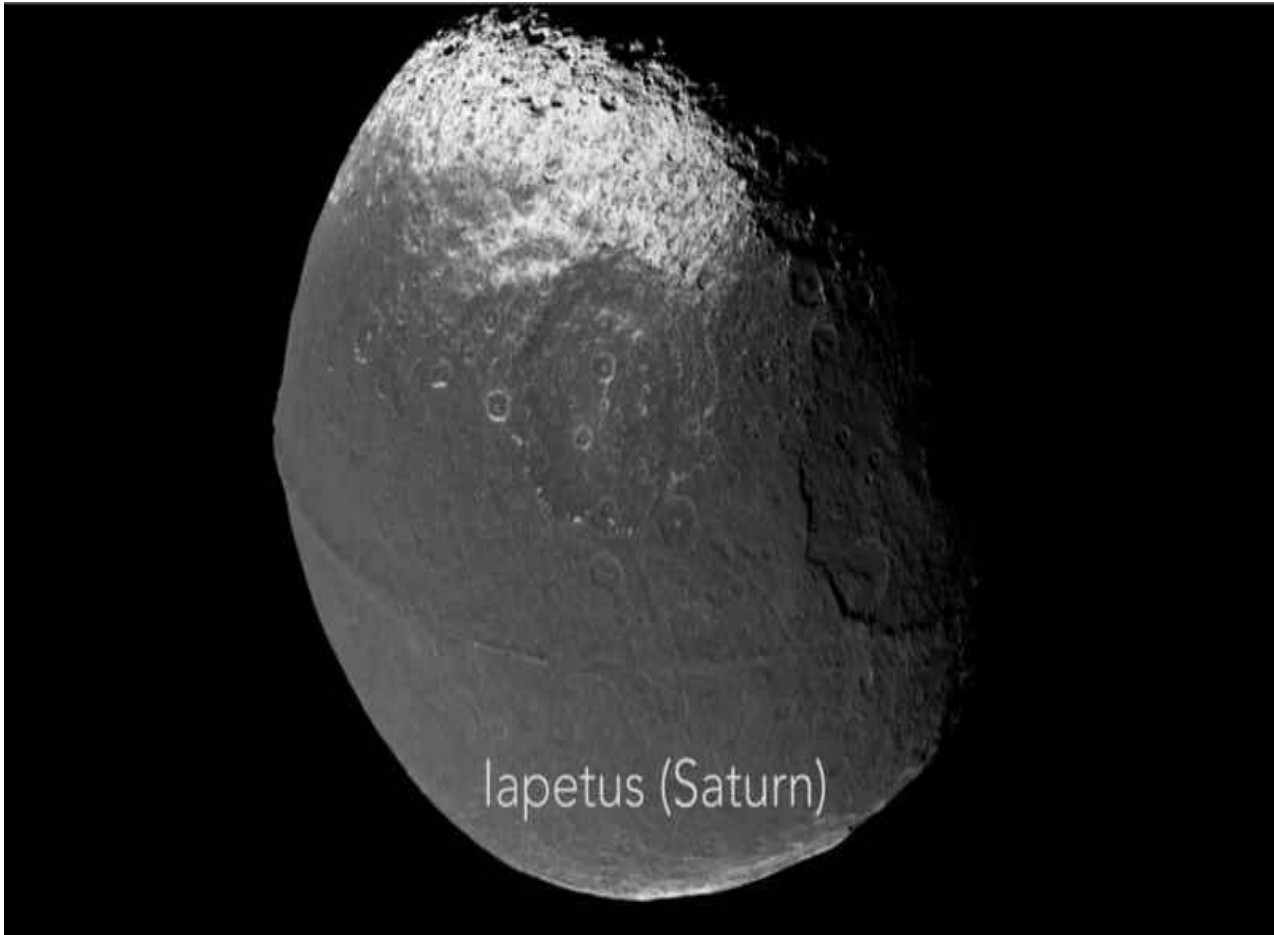

moon Iapetus has this very large ridge. It has weird geometric features, and the idea that somebody maybe built that as some kind of a weapons platform.

Is that the kind of thing that you were seeing here?

Corey: Yes, but it was happening so quickly, I wasn't able to hone in on all the fine details.

David: So they were moons that were weapons?

Corey: Right.

David: Wow!

Corey: And then . . .

David: And you just saw, you said, many, many different scenes of like attempted invasions and . . .

Corey: Yeah! Right.

David: Were the moons firing at things that also looked like moons?

Corey: No, they were giant spheres that looked technological, like spaceships.

David: Oh! Okay. Wow!

Corey: But they were really big.

David: That's really impressive.

Corey: Yes, but it was very upsetting to see them function. I was feeling anxiety.

David: Ah.

Corey: My heart was beating real fast. I was getting . . . breathing faster and faster as all this was occurring.

David: But let's just stop for one second. I think this is a really important point, which was that long ago you said to me that the Ancient Builder Race apparently constructed these to form a unified protective grid around our entire local star cluster so that nobody could get in and invade us, right?

Corey: Right.

David: And you also said there's a huge portal right nearby that you could get through to go to other galaxies, which could also make it an invasion route. So we're actually very vulnerable to invasion because we're right at the front door of the drawbridge for the castle.

Corey: Right. And that appears to be what was happening.

David: So this was all these invasions being repelled . . .

Corey: Right.

David: . . . by these intelligent technologies in these moons.

Corey: Right.

David: Wow! That's amazing.

Corey: The next two scenes that occurred were . . . I was extremely upset by them. I could see Mars, and it had clouds, it had oceans, it had large, I guess, island-like continents here and there at the top. You could see green.

David: How did you know it was Mars if it looked like the Earth?

Corey: I just did.

David: Okay.

Corey: Yeah.

David: Okay, fair enough.

Corey: And then you see Mars, and then you see one of these spheres going by like this, [**Corey** shows Mars in a fixed location and the sphere moving past.] and as it's going by, it's shooting electricity at it and ripping a big old gap across the planet as it's going by.

David: Oh, wow!

Corey: And all the water was turning to vapor, and there was all of this debris that was blowing out of the surface of Mars, blowing out of the atmosphere, and blowing away from the planet.

And other parts of the debris was turning red hot and falling back to the planet.

David: So you're seeing probably billions of people dying as this happens, right?

Corey: Yeah. It was a very upsetting feeling.

David: Gosh.

Corey: And there was one area . . . I think it was the area where the bolts had entered the atmosphere. All of this vapor was coming out of the atmosphere and freezing in space, like ice dust in space. And it was just pouring out from it.

David: Now, you've previously speculated on this show and in private discussions with me that there was a Super Earth, or we know there was a Super Earth because of Brilliant Pebbles, right?

There was a Super Earth that got blown up, and it apparently was, according to what Gonzales has told you, that their best guess was that it was done by one of these weaponized moons.

Was there any evidence of the Super Earth's involvement in this particular disaster that you saw?

Corey: The Super Earth for some reason, none of that was in any of the scenes that they showed me. I did not see the Super Earth. I did not see a destruction of a planet.

It seemed to be focused around Mars, because after I had seen that scene, I saw Mars again, but it looked more like . . . closer to like it does now. And I saw these flashes on the surface and then these real tall, skinning mushroom clouds . . .

David: Oh, boy!

Corey: . . . that had a tiny little mushroom bulb at the top and had these big rings around them.

David: Rings of smoke, you mean?

Corey: Rings that looked like . . . yeah, like smoke . . .

David: Okay.

Corey: . . . going out from them . . .

David: Wow!

Corey: . . . and these large oval, like a squished oval-shape, vessels were leaving in all directions. Some of them were headed towards Earth. Some of them were headed towards the outer solar system.

At this point, my heart was beating very heavily. I was starting to hyperventilate, so the scene stopped [**Corey** snaps his fingers] immediately. And the Sentinel disappeared.

And I looked over at Kaaree, and she was looking at me with a little bit of concern. And she asked me if I needed a moment – if I was okay.

David: Was she able to perceive what you perceived?

Corey: I don't know.

David: Okay.

Corey: I don't know.

David: Previously we had speculated on how the Super Earth was destroyed, and it seemed that when you asked Gonzales, that his best guess was that it was hit by one of these weaponized moons.

Do you think that the Super Earth and Mars were both hit by a weaponized moon during the same war, that those two events happened simultaneously? Because in the past, it seemed like your intel was that it did happen at the same time.

Corey: That was the intel that I received, but as I stated, the Super Earth was not in the scenario at all. It seemed to be centered around Mars.

David: So it's possible that the Super Earth had been destroyed, but that Mars did not get destroyed in that catastrophe like we thought.

Corey: Right.

David: Okay. We don't really have enough information to tell from what happened there.

Corey: There was no real context or linear incidence occurring. It was just these flashes.

David: Okay.

Corey: So I wasn't able to really place it.

David: Okay.

Corey: So I was pretty upset.

David: Okay. Right. That makes sense.

Corey: And I don't have a whole lot of emotion attached to Mars. So for some reason, I was very emotional about what was occurring.

David: Right.

Corey: It was very upsetting. You know, after Kaaree basically was like asking if I was okay, we got back in the Anshar vessel to leave. And I don't remember . . . I barely remember walking back to the vessel. I really don't remember the trip back, because I was just sitting there thinking and visualizing what I had seen.

And I asked her again, I said, "What was all this? What was the purpose for it?"

And she said, "Well, this was a repository of the Ancient Builders that was imparted to you."

And I said, "Well, I can't retain any of the knowledge. I can't pull any memories from whatever this repository is. What good is it if I can't remember it and report it?"

And she did her big smile and told me that it would make more sense in the future, in the near future.

David: Well, if we kind of connect some of the dots of the things that have happened in these updates, it seems like it's centering around the idea that if we don't pull it together as a planet that we're going to destroy ourselves again.

And you saw beings with elongated skulls, you heard from Gonzales the flash freezing, the blocks above the ground. Now you're seeing this catastrophe over here. You're seeing that the sun might do

something that could really damage life on Earth unless we're on the optimum timeline.

So why do you think all these different previous catastrophes are being shown to you now?

Corey: I wish I could tell you. I don't have any context. I mean, it's like you're receiving a bunch of information, but you don't know exactly how to apply it.

David: Do you think it could be like a warning sign for us now? Do you think that these visions were given to you to advise us that these things have happened and that we need to work harder?

Corey: It could be, but it would help me warn people if I had more details. Ha, ha.

David: Ha, ha. Well, these beings oftentimes work with mystery. You don't get all the answers. But it sure looks like there's some warnings here, to me.

Corey: Yeah. But on our journey home, I really don't remember it. I don't remember going back through the blue swirl to get back down to the big hangar. I was just . . . I was there, and the door opened, and we were getting ready to get out.

And I was . . . I felt very drained of energy, exhausted emotionally and physically. It was hard to walk. And I was walking behind Kaaree.

And shortly after that, they sent me back to my room – the same method of flash. And I was still in my clothes. I was exhausted. I climbed into bed, and I laid down, and I slept.

And then when I woke up, before I went in to interact with my family, before I could, I sat there and thought about it for a long time, thought about everything that had happened . . .

David: Yeah.

Corey: . . . and was trying to access this information that I could . . . If you can feel information here and you can't access it, you feel like you've got some sort of neurological issue, you know. It was a weird feeling.

David: And yet you were given this dizzying snapshot tour of your past lives, apparently.

Corey: Right.

David: So that is like maybe some kind of fast forward or fast backward through that data file.

Corey: Right.

David: Okay.

Corey: So, you know, that's how it ended. And since then, I've had more meetings with Kaaree in "The Construct". And it's been mostly of a personal nature or a nature of how I should interact with those around me in a way that would work out the best.

David: Basically be nice?

Corey: Yeah.

David: Ha, ha, ha. Okay. Well, this has been a really fascinating, dizzying journey. And I just have to offer the personal remark here of how the cross-over between these things blows my mind.

There's obviously somebody wanting us to really put this history together and understand it.

Corey: I agree.

David: So I want to thank you for continuing to do this work. I know it's been very hard on you and your family.

And I want to thank you for watching. This is "[Cosmic Disclosure](#)". I'm your host, [David Wilcock](#), here with **Corey Goode**. And we appreciate all your help in getting the word out with Full Disclosure.

[Cosmic Disclosure: Validating the 20 & Back Program with William Tompkins](#)

Season 6, Episode 4

[David Wilcock](#): All right. Welcome back to "[Cosmic Disclosure](#)". I'm your host, [David Wilcock](#). I'm here with **Corey Goode**. And in this episode, you are going to get some of the most shocking, amazing confirmation of the reality of things that **Corey** has been telling us on this program for over a year now.

We have, for you to see, filmed discussions with **William Tompkins**, the aerospace engineer, who

confirms some of the most incredible aspects, and the most unbelievable aspects, of what **Corey** has had to say.

And he gets very specific. The level of specificity in what you're about to see is so extreme that the idea of this being a coincidence does not make any sense.

Tompkins does not have Internet access. He does not have an email address. He was completely unaware of who **Corey Goode** was at the time that this was taped. And when we showed him a photograph of a Draco, he said, “What the hell are you guys doing here?”

He was shocked. And this is information that he came in to on his own. So without further ado, check it out.

20 AND BACK



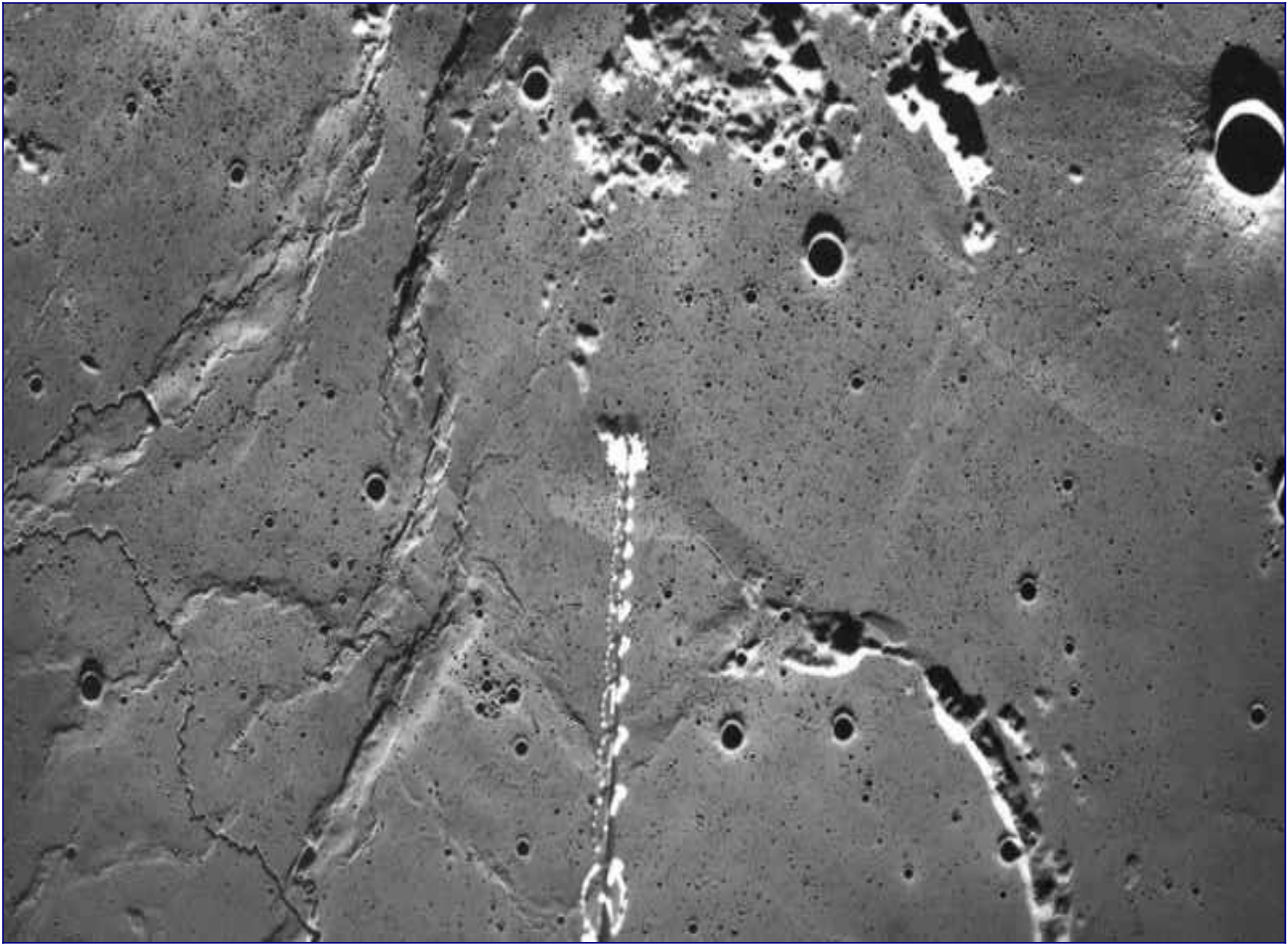

William Tompkins: Thousands, thousands, not just a few, thousands of people have joined the Navy here in the United States. They joined the Space Navy. They signed up for a 20-year tour.

So these folks, men and women, were given a lot of examinations and a lot of information on what they were going to need.

Many of them went to the Moon, our Moon, and facilities there and got checked out and organized and established where is the best place they're going to go, what their criteria is going to be, what major area they're going to develop, like what class in the university.

And then they get sent to a Mars facility for a short time.

And some of them get to Jupiter's moons, where we have a large facility on the moon.



And then they get assigned to a specific base. And they work for a short time in the base before they're assigned a naval cruiser, or a naval attack vehicle, or even a naval spacecraft carrier, which are one, two, and four kilometer long class.

And we have eight of those battle groups out there. So there's plenty of room for new people to come aboard.

And so they do their tour then, most of it on the spacecraft carriers, or the supporting ships. And some of them are supply ships – not as much fun, but they needed to be . . . We need people on them, too.

So at the end of the 20 years, they have an option for another 20 years. They could go for another 20 years. Or they have the option to come back to Earth where they were born and where they entered the Navy.

And then they make this decision they want to come back. So they age regress. They're now 20 years older than when they joined the Space Navy, okay? And so they take several weeks or several months, and they reverse their age back to 21 when they joined the Navy.

They finished their Navy 20-year tour and they make the selection to go back to the United States.

Now remember, during that 20 years, they had no contact with their family or with anybody back on Earth. That's a prerequisite. Okay? So . . . But they remember their family. They remember their friends and the people they used to go to and some of the girlfriends they used to have.

And so they come back, but they were 20 years older when they left the planet. So the girlfriends are going to be a whole lot older.

And so the Navy has allowed them, in the Solar Warden System Program, to go back to the age that they were when they signed up. Okay?

Well, you said that they were 20 years old when they signed up, and they went a 20-year Navy tour. They came back. And now they're 20 years old, and they are in a situation where life is this 20-year-old life that they had going when they left.

And now, during that several weeks returning, their minds, not painfully, but their minds are played with to where 90.99 [percent] of their memory for the last 20 years out in space is removed.

So they're sitting there now, the girlfriend is the same age as she was. Wait a minute. She wasn't 20 years older, like we said. She's still the same age.

If he was married, his wife, the kids, were the same age. They didn't spend 20 years more life. So he comes . . . That's kind of a cool system. Okay?

Yes, that system is operating and has been operating since 1980.

* * * * *

David: All right. So as you've just seen there, what the heck is going on here? The only way somebody is going to be able to debunk something like this is to try to say that **Tompkins** and **Corey** were speaking to each other, but we know that that never happened.

So **Corey**, welcome back to the program.

Corey Goode: Thank you.

David: How did you feel when you saw this? Let's just start simple. Ha, ha, ha.

Corey: Well, I was always under the impression that under a certain level people did not know this information. So it's very . . . It's exciting and a little shocking, but the details that he gave were right on.

David: Well, he started out by saying that thousands of people are recruited into some kind of a Space Navy. How do you feel about that number? Do you think he's right when he says thousands?

Corey: It's definitely in the thousands.

David: Okay.

Corey: Yeah.

David: Thousands per year or thousands overall?

Corey: Over . . . I mean, it's definitely going to be in the thousands, several thousand that's going to be . . . that have been in the program – 20 and Back Program – overall.

David: Okay.

Corey: So it's a fairly large number.

David: Now, one of the other things that he said that's a little bit different than what you've said was first of all, he said people get trained in the various areas of specialty that they want to go to. And then he said that they go to Mars. Whereas you seem to have said that the LOC [Lunar Operations Command] is the first kind of stopover point.

Corey: It usually is, yes.

David: What do you think could be going on with Mars where it would become a contact point for people that are joining the Space Navy?

Corey: Well, depending on what your duty is going to be, you're going to be taken and trained at a different facility. Let's say that they had deep space telemetry – just pulling off the top of my head – if a person was going to do that, then just like if you were serving in the Navy here on Earth, they're going to send you to different bases where you're going to get the best training before you rejoin the vessel you're assigned to.

David: Is there any one sort of main reception area on Mars, similar to what there would be with LOC?

Corey: Not that I know of.

David: Okay.

Corey: Right. But it's a little bit different for people that go in as career Navy. They go through a little bit different process than civilian assets that are pulled in, such as the MILAB people, and there are others that are pulled in, too, - scientists.

David: When I was speaking with Henry Deacon, he was the first insider I had access to who said that he had worked on a facility on Mars. And he had told me that there were 200,000 personnel at the time he was there, that it was rapidly expanding.

And the funny part to me was when he said that only 10,000 of those personnel were actually Earth-born humans. I'm wondering if that correlates with anything you've heard. I mean, we can't get him on camera like we did with **Tompkins**. He doesn't want to talk, but . . .

Corey: Yes. Yeah. The population from like . . . They brought a lot of people in during the Brain Drain era, and then those people . . . you know, there's been two or three generations at least of people that have been assigned to these . . . or have been living on these bases.

David: So could Deacon be right that there could be a base with 200,000 personnel in one spot?

Corey: Oh, absolutely. Yes.

David: So they're that large?

Corey: Yes. Some . . . Yes, some of them are very large.

David: Okay. Another thing that **Tompkins** said, which I found provocative, was that he said there were eight battle groups. When you start hearing specific numbers like that, he's either going to be right or he's wrong. And he seemed very confident when he said that.

So I'm curious as to your reactions to that.

Corey: Yes. There were eight different battle groups.

David: There were?

Corey: Yes.

David: Wow!

Corey: Yes. And that was during the Solar Warden era. These craft are still . . . Most of them are still in service, but you have different fleets with carriers, destroyers, supply ships, all kinds of support craft.

And during the time I was in, there were eight different battle groups.

David: How could you classify them? Why would there be eight? What were they doing? Where were they going? Were they different?

Corey: They were made up of the same range of vessels.

David: Okay.

Corey: You know, like you have several different types of destroyers and carriers in the Navy that most people are aware of, and you'll have several battle groups or actual fleets out there going off doing different missions. And it's very much the same. They're off doing different missions and aren't really in each other's business that much unless they're called to support each other.

David: So it's not like we would have three of the eight battle groups hanging out in our solar system, necessarily?

Corey: It just depends. A lot of time they'll be behind the Moon or further out in the solar system, closer to other bases, in an area where they're going to be behind a planet, not just hanging out, because they have to do that because you have astronomers here that are tasking satellites to look around.

And they always make sure they know where every asset is in space. And they know where astronomers are going to be looking. So they're able to hide the fleet.

David: Can you remember the names of any of these battle groups or what were their designations?

Corey: I can't. I remember that they had a . . . There was a 01, 02, 03, but I did not . . . We really didn't interact with the other fleets. And I didn't really interact with other vessels in our fleet.

David: Approximately, how many vessels are in a battle group altogether? Does it vary, or is it . . .

Corey: Yeah, it's going to vary. But sometimes they'll take some out of one group and assign it to another group depending on the mission.

But there's well over a dozen in each. And we're talking larger vessels. And then they have many, many more support vessels.

David: Did any of these battle groups ever get into a war that was significant enough that they lost a major amount of their assets?

Corey: There have been conflicts. They've had vessels that have been damaged so badly that they've lost them. And they've had vessels, also, that they've had to send to be repaired for extended periods of time.

David: Is there any conflict that kind of gained a legendary or historic significance? Was there ever a conflict with the group that they really were not prepared to handle? Something like that?

Corey: In the beginning, there were several incidents of them going into areas around Jupiter or Saturn that were off limits, and having their rears handed to them.

David: 'Rears handed to them' translates as what?

Corey: Well, they would be attacked by sophisticated weaponry from non-terrestrials.

David: Okay.

Corey: There were certain areas around certain planets and planetoids that are off limits, and if they accidentally, or purposely, go into those areas, they are warned and then they're attacked.

David: I'm curious if they ever . . . I mean, I'm thinking a lot about “Star Trek” right now, and I'm curious if they ever came across a truly outrageous extraterrestrial menace that was a lot more significant than most of the other negative extraterrestrials might be – if something like that ever happened to them?

Corey: There were incidents where vessels traveled into different non-terrestrial areas, and they were hit with very advanced weapons, like the torsion weapons, that the inside of the craft would be twisted and pushed in.

David: Oh, wow!

Corey: And when they had that significant of damage, the vessels had to be, basically, taken apart in certain areas and repaired.

David: You know, when we start looking at the fact that the space program, as he said here – and we'll get into that part in a minute – but 1980 Solar Warden, he's giving the same dates that you've always been giving us.

And then we have “Star Trek: The Next Generation” come out in the late '80s that has so many

crossovers. Do you think that there was any communication from the space program to producers of “Star Trek” in any way to help seed this stuff into our consciousness?

Corey: Yeah, most likely from defense contractors' companies. A lot of times, maybe even associated with the Interplanetary Corporate Conglomerate.

David: Right. So if we're getting into this much specific detail from **Tompkins**, do you think there's any way that **Tompkins** could be lying at this point? I mean, it doesn't seem possible to me.

Corey: No, not with his credentials and the detail of the information that he has. And the fact that, as you said, he doesn't have Internet access. He doesn't even have an email address. I don't think so.

David: It is very clear that he worked for defense contractors. And here, we're seeing the most astonishing part of this thing, he talks about people going out for 20 years and then being brought back and age regressed.

Corey: Yeah.

David: What was your idea of when the 20 and Back actually started?

Corey: The 20 and Back, I was told, started just a . . . They had been planning it and working on it and had plans to implement it for a while, but it wasn't actually implemented until the . . . right after Solar Warden was implemented around 1980.

David: Wow! So this is an exact correlation that you were hearing.

Corey: Yes.

David: Now, he mentioned that the technology to remove memories, he said 90.99, but I think he meant 99.99 . . .

Corey: Probably. Yeah.

David: Would you say that for the people who are not among that 3% or 4% that it is actually 99.99%? Correct?

Corey: Yes. The only types of memories they might have would surface in dreams. And they wouldn't have any context for it, so they wouldn't really pay any attention to it.

David: So if you go out there and you do this 20 and Back, and you're recruited in from the Navy – as he said the Space Navy . . . thousands of soldiers are doing this, if they're going to mind wipe you and leave you 99.9% blanked out, does that mean that you then are going to have to do a normal military service afterwards once you come back?

Corey: A lot of the times how they did it was they would give . . . Like someone would sign up for four years or eight years, and they would be assigned to a project that would then take them off planet.

And then, after they were regressed, they would come back and serve out the rest of their 4~8 years.

David: That's what I would expect, because otherwise if you sign up for the military and they splice you back in, and then you don't have any military service, what happened?

Corey: Right. And there were people that I ran into that had said that they had served multiple 20 and Backs.

David: Multiple?

Corey: Yes. And they looked around the same age as I was.

David: Do they have the opportunity to remember the ones that they did before when they're on another one? Or does it all get blanked out?

Corey: It depends on what they were doing. If they were doing something that . . . If they were working for one of the different space programs being lent out and they witnessed or worked on things that they were not allowed to disseminate back to their Solar Warden group or on their craft, they would wipe a certain amount of information.

But you weren't completely blank slated until the end of your service.

David: If this technology to age regress people is out there, and we have the Cabal who does not want people to live longer, do you think that that's one of many reasons why they don't want disclosure because of the life extension tools they have?

Corey: Absolutely. Yeah, they want the Earth to be pretty much . . . You know, a lot of the . . . Not all of the people, but the Cabal people would like the Earth to be cold. We've all seen the different scenarios they'd like to see play out.

David: So this technology, if it were to be a Full Disclosure, you could assume that there'd be people who all start wanting age regression and start demanding it. Like, "Well, wait a minute, I'm 74 years old and my body is failing and this is my last chance." And then all the people are going to say, "Save my grandfather," and all this stuff. And it could get to be really crazy.

Corey: Yeah. And not to mention all the healing technology to where they can go in, look through your body, find a frequency of cancer, and then nullify it.

David: **Tompkins** also mentioned that these people were not allowed to have any contact with their families or Earth for those 20 years.

Corey: It's absolutely correct. And not only that, they're not allowed to have access to radio, television or Internet coming from the planet.

David: Was there any form of suitable entertainment that would keep them occupied while they were out there for 20 years?

Corey: Yeah. Strangely, and this will sound kind of weird, there was a lot of ping pong played.

David: Ha, ha, ha.

Corey: But . . .

David: Yeah, that's the same thing that Henry Deacon always said, that when he was at Mars base that he mostly spent his time playing ping pong.

Corey: Yeah, they had recreation areas built. And they had movie nights that I really didn't go to very often. But . . .

David: What were the movies?

Corey: They were all old movies that were before the time you would've gone in. So there were a lot of old cowboy movies and old war movies - World War II movies.

David: But nothing was allowed from the time after they left because it would screw up the future.

Corey: Right. And also, if someone does come back and they do have recall, and you've been watching the Internet and television, it would give you a big advantage in the stock market and other ways, too.

David: I know we've talked about this before, but I'm curious as to how many people you think there are on Earth now who have been blank slated and don't remember anything, but actually did this?

Corey: It's . . . That is in the tens of thousands. People that were involved on one level or another that were pulled in for . . . Some people . . . Not everyone puts in 20 years. They'll have engineers or egghead scientists of different fields that they will pull in for shorter periods of time. I heard them say 8~10 years. And then they will either be reassigned or they return.

David: I know that for a while you worked in what you call the Intercept and Interrogate Program, and I'm wondering if there was ever a time where somebody from the space program starts to remember things and they have to be contacted and given a briefing or given a mind wipe or something like that?

Corey: Yes. They monitor people, as well, afterwards. So kind of like the NSA, you know, the haystack kind of thing, they pull all of your information in and they have behavioral scientists that will look for any signs that the programming is breaking down. And if so, they'll pick you up, bring you back in, debrief you to see exactly what you do know, and then will blank slate them.

David: Now, I notice in this episode that you're a lot more articulate than you used to be and there's been some scuttlebutt on the chat room that you've been replaced by a clone.

Corey: Yes.

David: Could you explain to the audience so that we can stop this rumor why is it that you've become so much more articulate lately?

Corey: Well, when I first started shooting "[Cosmic Disclosure](#)" with you, I, as you know, I was going through a lot of surgeries. I had rotator cuff and bicep reconstructive surgery, and I was on pain pills and Xanax and things that definitely slowed me down.

When I watch old episodes, it's difficult for me to even watch.

David: Right. So it is really you, it's . . .

Corey: It's me.

David: - just less drugs.

Corey: Yes. Yes.

David: Okay.

Corey: No pharmaceuticals in my body.

David: Ha, ha, ha. All right. So now what we're going to do is we're going to see another discussion with **William Tompkins**. This time, some amazing material regarding the split that took place between the existing Solar Warden program and what came to be known as the ICC [Interplanetary Corporate Conglomerate]. Let's take a look.

INTERPLANETARY CORPORATE CONGLOMERATE

William Tompkins: Because of lack of understanding and a lack of acceptance of the subject matter of extraterrestrials . . . This is staggering, because it's not just many of the extremely well-educated people in the country working on this not wanting to accept the reality of what we were in to, but they even participated in trying to nullify the program – throw wrenches into the gears.

And even at Douglas, over at TRW, and all of these other companies, General Dynamics included, there were the top-level people who were throwing negatives on everything that we were attempting to do.

So you have to ask the question, “Why do we have so much of this at such a high level in technology in the country, in the whole military?”

And who is telling them to try to stop everything, try to cut it down when we're trying to help ourselves? And supposedly that's what the military is for.

But the corporations, at the same time they were doing the military mission programs, they were doing other programs which could possibly allow them to nullify the space programs of the military, like Solar Warden.

And these people, then, utilizing all the advances in space systems, military wise, developed the capability to move off the planet and mine materials on other planets in the solar system and/or continue on out into the galaxy through the 12 closest stars, Alpha Centauri being the first, and mining or extracting materials, or whatever, and making money.

This same group of top corporate people of all these companies that are doing the jobs, that they are getting paid for, were paralleling the space missions for industrialization – making money.

It just seems really strange that this is where we would be finding ourselves because they're using all of the best capabilities. It's already been done for them.

We've got corporate operations operating parallel to missions to solar system planets and other stars' planets, doing the same thing.

The word is greed. Whatever helps them financially, this is where they're going to put the money. This is where they're going to do all the development.

* * * * *

David: So, **Corey**, what are your initial thoughts after seeing this particular discussion with **Tompkins**?

Corey: Wow! He's obviously talking about the Interplanetary Corporate Conglomerate, which we've done an episode on. And it's all of these different technical corporations and companies that support the military-industrial complex that have formed their own breakaway Secret Space Program.

And, as he said, they mine. They actually are the ones that build most of the facilities out in space.

And what he said matches perfectly with this corporate group.

David: There was an interesting line of inquiry in here that I haven't really gotten from the way you and I have talked before, and that was that he mentioned that there was a lot of intellectual difficulty, resistance, that people had to this concept within the contractors and the companies that were actually working on this stuff.

It's almost like they didn't want all of this to be true. And he seems to be saying that from that rivalry was born the defense contractors not wanting to be part of some peaceful space exploration think like “Star Trek” or a protective system for the solar system. They want to go off and do their own thing.

Corey: And they didn't want their hands tied. If they work through Solar Warden, they have to abide by the rules of whoever's in command of a certain project.

David: Ah!

Corey: So if they do it through their corporate means, they have no oversight or no accountability.

David: So they did this without any other approval but their own, I assume.

Corey: Right. They already . . . They had the most advanced toys, weaponry, vessels. They had . . . It was far superior to what they were handing over to the military groups. So there wasn't a whole lot that the military groups could say because the military groups also relied on them so much.

David: Wow! I guess I'd never really understood how much of a rivalry this thing was all the way back then.

Corey: It's a rivalry, but it's not an open tit-for-tat situation between the two groups, . . .

David: Right.

Corey: . . . because they worked together. They lend each other resources, as well.

David: Now, he mentioned that there were 12 neighboring stars in which there were missions and, apparently, construction going on in those areas, as well. That seems a little bit different than some of the things that you've said, but again, we're dealing with fine tuning some minor things. So what's your reaction to that?

Corey: Well, I know that there were plans to do that, but the only problem was these other solar systems have inhabitants, and these inhabitants have space programs. So, you know, they can't just go into a star system, say, "We're going to take the last planet in your system; we won't bother you," and set up a base, unless they have a diplomatic relationship.

And at the time I was in, I was not aware of diplomatic relationships that allowed us to build all of these different bases in their star systems.

However, I was brought to the Galactic League of Nations base that was on a moon going around a gas giant that most likely was built by ICC assets.

David: Now, do you think that the ICC command structure has now gone completely off planet, or because they are essentially defense contractors, is there still a merger between what's up in the solar system and what's down here on Earth?

Corey: Well, some of them are out in the solar system. Many of them are down here. They are usually like at the head. Let's say . . . I'm just using an example.

TRW has an executive that's been with the company for 20 years, has all the background to be an asset to the ICC. They will say, "Listen, why don't you retire and then we'll move you over to our Super Board?" They call it a Super Board. And this is a board that has members from all of these different corporations that are a part of it and they make decisions.

David: You had mentioned before, and I want to get a little more clarity on this, that some of the products that the ICC uses actually are made on Earth and then they're just shipped up there.

Corey: Yes, some. Yeah. And sometimes it's . . . parts are made here and there. It's shipped up, and then mixed and matched with parts that they've made off planet.

David: What percentage of the people in this defense contractor community . . . How many of them do you think know about what's being done up in space?

Corey: That's unknown to me, but I would say very, very, very few, because the people that ended up serving on the super boards were not given a lot of information, or were not privy to a lot of information, until they became a part of the Super Board and then they were briefed.

David: So if, for example, something benign like seats could be designed on Earth and nobody knows that this is a seat that's going to end up in a hyper-advanced craft, they're so compartmentalized that that seat would only . . . They'd just build it, but they don't know where it's going.

Corey: Right. Right. Or they'd just build part of it, and then it's put together, either off-world or somewhere here, by assets that they know that they can trust, and then shipped out.

David: So people could be building technology that's actually used in very elaborate ways and never have any idea what they're doing.

Corey: Absolutely. They can do it their full career, retire and spend the rest of their life being unaware.

David: How do you think somebody like **Tompkins** was able to find out all this information? What was his most likely source?

Corey: The level of information that he's reporting had to have trickled down from pretty high. And it sounds like a lot of his information is coming through the Navy. And right now, the Navy is in kind of a contest with some of the other groups to have this disclosed.

And it's not all of the Navy. It's groups within the Navy that want the Secret Space Program disclosed.

David: Do you think that this ICC has participated at all in what we're calling the SSP Alliance?

Corey: The SSP Alliance is made up of people that broke away from all the different space programs. So there are former ICC assets that have joined the Secret Space Program Alliance.

David: What do you think the ICC alliance members' goal is? If they were part of this thing and he's saying in this discussion that it was mostly greed-based and making money, do those people that are participating in that system, are they benefiting from that greed and that money?

Corey: Yes. It's cosmic capitalism. Some of the things . . . They're trading, as well. They're trading biological and technical assets to non-terrestrials for technology. So the Interplanetary Corporate Conglomerate were one of the groups that were most involved in like the galactic slave trade and trading different assets here in our solar system for assets from another solar system.

So when they receive them, then they go through R&D. They back engineer it. And then they use either the concepts or actually reproduce the technology to use in their ICC group, or it's taken to Earth and then disseminated somehow and put into our technology and released.

And they receive money that way through the corporations. They have this Super Board. The Super Board wants to grow the corporations and make them profitable. It's all about profit.

David: Well, I understand the profit part. And he is mentioning greed here. However, in some of our earlier episodes when you mentioned actually going to ICC facilities, it did not appear that those people were making money or having a luxurious life at all. In fact, it seemed quite the opposite.

Corey: Well, let's look at corporations here that use child labor in other countries. You see the product come. It's in a real shiny box. Everything looks American, but you don't know the history behind the product. It was put together by almost slaves.

David: Right.

Corey: So these people are not reaping the benefits that the ICC is gaining.

David: So do you think that the upper levels of the ICC, where profits are able to be shared, that they have facilities that are a lot nicer than what you saw?

Corey: Yeah. I'm sure they do. The ICC, they always had the best of everything. The newest toys they tested and disseminated some of it back out to the military groups and other space programs.

David: When you have had briefings from the Blue Avians about the future after Full Disclosure, they told you that various facilities would be handed over to the people. Would that include ICC facilities?

Corey: Absolutely. Some of the ICC facilities were what the SSP Alliance was attacking and trying to take out, and the Blue Avians told them to basically stop – knock it off. All of this infrastructure, once there's a Full Disclosure event, this whole infrastructure is going to be handed over to the people of Earth.

David: Well, that's a pretty exciting future.

Corey: It is.

David: Do you think that there is some kind of Draco involvement with the ICC? I know that the Dark Fleet, apparently, has a real strong Draco component to it, but what about the ICC?

Corey: They work with, literally, thousands of different groups. So I am sure there's a crossover there.

David: Do you know if the Draco have control over them to some degree or is it really just the defense contractors that hold the power?

Corey: I'm sure that there are non-terrestrials that exert some sort of influence over them, but they're pretty much a Earth-based group that are interested in pushing forward their own agenda.

David: All right. Well, you saw it here first. This is “[Cosmic Disclosure](#)”. I'm your host, [David Wilcock](#), here with **Corey Goode**. And we're reviewing footage from **William Tompkins** – absolutely mind-blowing stuff. Thank you for watching, and we will see you next time.

[Cosmic Disclosure: Arrival of the Spheres with William Tompkins](#)

Season 6, Episode 5

David Wilcock: All right, welcome back to “[Cosmic Disclosure](#)”. I'm your host, [David Wilcock](#). I'm here with **Corey Goode**. And in this episode, we have another round of incredible disclosures from **William Tompkins**, our 94-year-old aerospace engineer.

This man does not have Internet access. He does not have an email address. He was completely unaware of who **Corey Goode** was or what he had said at the time that these tapings were done.

But yet, what he is about to tell us in this episode is, again, going to be one of the most significant things we have ever done with this show, because the amount of correlation that you are about to see here is utterly mind-blowing.

So without further ado, let's check out what **Tompkins** has to say. It is going to rock you. Take a look.

* * * * *

SOLAR SYSTEM LOCKDOWN

William Tompkins: As far as our situation now today, It's been accepted that we have a number of different vehicles, which are actually planets that are hollow, that move through the galaxy to monitor good guys and bad guys, wars and no wars, people taking advantage of other people on different stars' planets, and that, as of about a year and a half ago, one of these parked just outside of the solar system.



And it has been there for the past year and a half. And this vehicle is quite large, and it has over 2,000 different extraterrestrial civilization people on board as observers and as monitors.

And it's parked out there, monitoring what's been going on here since the Romans, since way before the Romans.

They have blocked the extraterrestrials who are here, are underground in the caverns, from leaving, and they're not allowing their buddies to come in.

I understand that there's two goals. One of them is to nullify the problem with the Sun.

The Sun is alive. Okay? Stars are alive. I think it's a hard time accepting this. And they have moods.

And essentially, we have to go back to the . . . I'm not making this complicated, but we have to go back to the center of the galaxy.

What's going on there?

And there's not too many stars in our galaxy compared to a lot of really big ones, but all of the stars are affected in some way by the Sun.

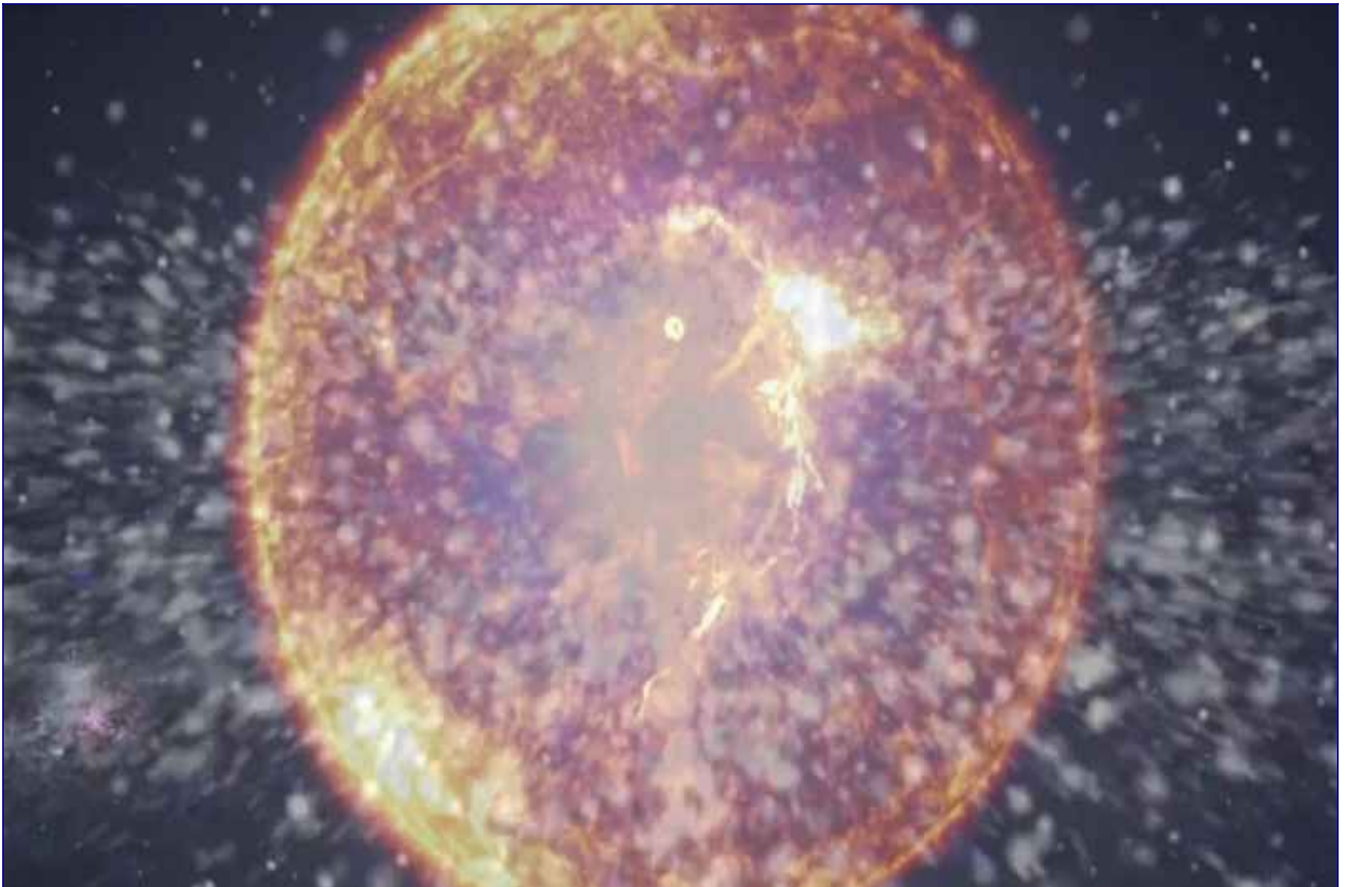

If the Sun sneezes, all of our communication – radio, electronics, everything – is affected.

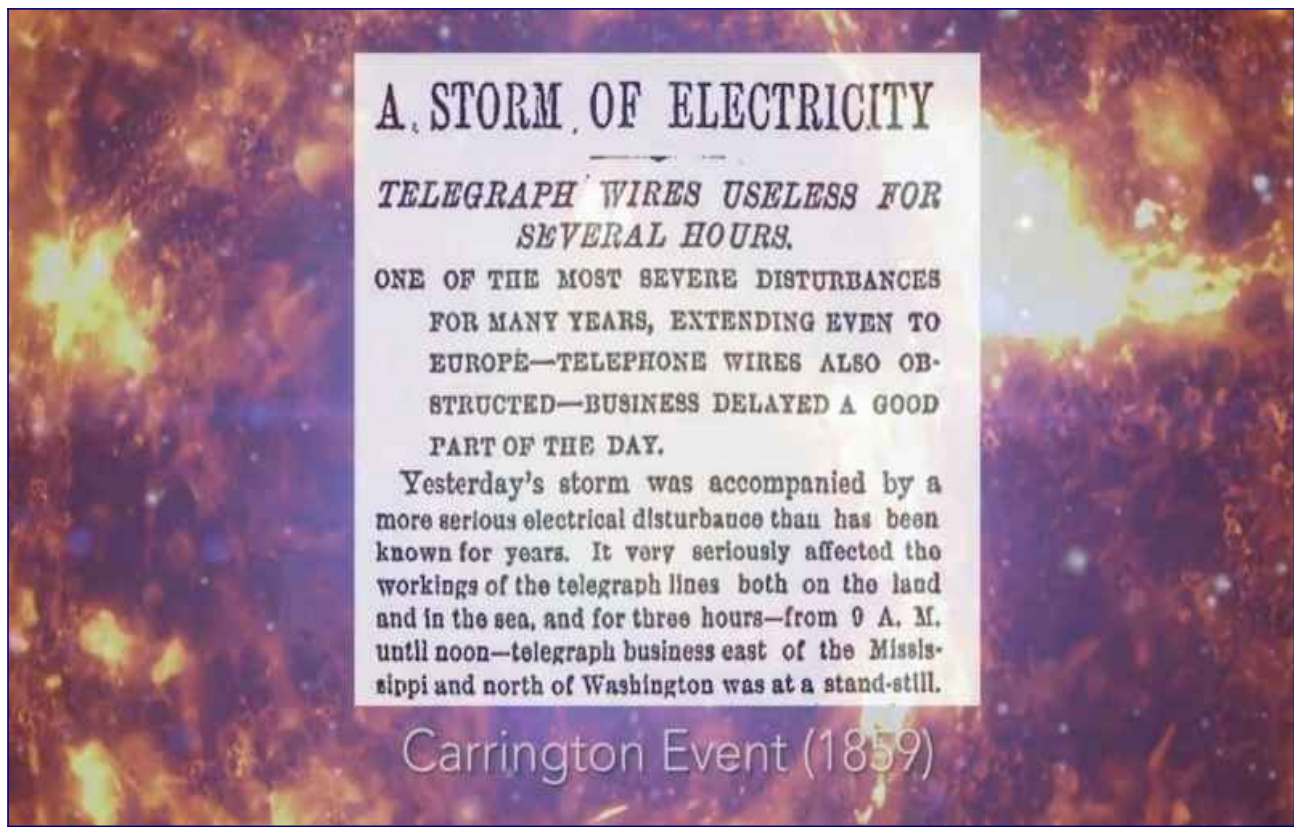

So there's this group of people, whatever you want to call them, who are attempting to primarily nullify the effects to a region, which is not just like the solar system or our star's system, but do this as a business so that the levels of catastrophes, things that cause dangers to the people and to the planet, are less.

So we can be easily affected. Our attitudes, our daily attitudes, can be changed. We can end up being a really good Republican, and for some reason we're going to change over and be the other guy.

The beings that are in that sphere, they're not agreeing with the Sun. That's just one thing they're not agreeing with.

They're very concerned about Reptilians implementing situations which are not tolerable in their way of life, and that this needs to be corrected.

They must have been doing their homework long enough to where they feel that little planet Earth has had it for a long enough time, and that that needs to be corrected.

* * * * *

David Wilcock: All right. Well, that was very, very interesting stuff here – just so many correlations popping out all over the place. I don't even know where to begin.

Corey Goode: Packed full of information.

David: He starts out by talking about planet-sized objects, that it's now considered a common fact on the inside track there that there are various extraterrestrial species going around and, he said, monitoring other solar systems with these planet-sized objects.

What do you think exactly they're monitoring for?

Corey: Apparently, there are groups that go from star to star, or star cluster to a star cluster even throughout the galaxy, that are monitoring the progress of different worlds, and they also monitor to see if there's any intervention occurring from outside groups, which . . . it would kind of be breaking like the “Star Trek” nonintervention . . .

David: The Prime Directive.

Corey: The Prime Directive.

David: So he mentioned that these planet-sized objects are also looking to see if there's a war, if something unfair is taking place. So in certain cases, they might also take proactive steps to preserve that Prime Directive?

Corey: Yes, but in a way that would not interfere openly with the inhabitants of a certain planet that they're wanting to progress on its own.

David: So then he seems to be saying that he believes that that's happening here, that one of these spheres is taking proactive steps here.

Corey: There's been intelligence. And I think you reported on one, I think in the '80s. One of your whistleblowers told you that one of these types of objects, a tangible sphere that was very large, came in and was cruising around the different planets.

David: Yeah, they called it The Seeker, and it had portholes on it that were 800 miles wide when they opened up . . .

Corey: Wow!

David: . . . and all kinds of ships coming out. And it was dark. You couldn't really see too well inside when it opened, but it opened up like a circle.

Corey: Right. So my intel has not told me that there are these type of spherical craft outside of our solar system that are preventing people from coming and going.

The intelligence I had was that the spheres that came in were these energetic spheres. So this could be different intel, or it could be intel that's been passed down after going through several different sources, and then it's kind of like the telephone game.

David: Right.

Corey: It slightly changes as it goes. And if people have different agendas, they can curtail it a little bit.

David: Now, I want to address this, because I don't want people in the comment section to think that, "Oh, well, they debunked **William Tompkins.**"

There is a slight mishap in his wording that we need to talk about here, and that is that he mentions, first of all, a year and a half ago that one sphere showed up outside our solar system. But then he said that it's been here since Roman times.

Corey: I think that he probably meant that these have been coming and going since that period.

David: Okay. So do you think that for him to have said this, that he must have heard it from someone else, that this was intel that he had received?

Corey: Absolutely. Yeah.

David: Okay.

Corey: It was intel that had trickled down from the higher Secret Space Programs.

David: Could you just briefly, before we discuss the timelines here, briefly review for us how did the outer barrier get started? What was the inciting incident that led to that happening, and when?

Corey: So these energetic spheres had been entering the solar system for a number of years, through both the Sun and from outside the solar system. So they knew that these spheres were around and that these spheres were monitoring them.

David: The Cabal knew?

Corey: The Cabal knew. And the inhabitants . . . They thought that these spheres were full of aliens. And they were trying to hail them to communicate, and they were getting no communication back whatsoever.

So at first, they thought that it was the return of the Sumerian gods, and a lot of them got really excited. But soon, they discovered that this was not a group coming in to help them.

So eventually, they decided to use an experimental new weapon. The actual weapon was in Australia, and I found out that the targeting happened from somewhere in Africa, in Southern Africa.

David: Mm. Okay.

Corey: They locked onto one of the moon-sized spheres that was actually out past the Moon just a little ways, and they fired on it. And when they did, the energy was just redirected back at the location it was fired from and it destroyed a portion of that base and killed a lot of people.

David: And as I've reported, the ISS caught a video of this.



There's a red laser with a little red glow around what appears to be something, and, in fact, NASA had to come out and make a public statement in which they said, “Oh, this was just a test to try to create an artificial star using laser technology.”

So they actually had to make an official denial. That's how big this was.

Corey: Yeah. It's kind of a ridiculous one.



David: So what were the ramifications of this attack on a sphere? How did that change the game?

Corey: When that attack occurred, immediately what they call the Outer Barrier was established, which was basically one of these exact same giant spheres that was now larger than our entire solar system and contained our solar system.

David: The sphere expanded?

Corey: Yes. On the level that these beings are, that is really of no consequence. Size . . . It doesn't really matter.

David: Right.

Corey: So they established this outer barrier to prevent anyone from leaving to escape or calling in reinforcements.

David: Now, given the fact that **Tompkins** was interviewed in the early summer of 2016, that's this footage that we're seeing, that's a year and a half ago from the time that he was talking that this happened, December 2014.

Corey: Yes, and that's what leads me to believe that there was some crossover of some other intelligence above him as it was trickling down, because there were reports of these physical giant spheres that were coming and going, but during this time period, it was one giant energetic sphere that encapsulated our solar system to prevent people from coming and going.

David: So perhaps that's why he thought there was only one sphere?

Corey: Correct.

David: Wow! My role in this show is to ask you questions, but I just have to make a personal statement, which is it absolutely blows my mind that he has the date exactly the same of what you've been telling us, and he doesn't have any access to you.

Corey: Right.

David: How did you feel when you saw that?

Corey: Well, I think you saw the look on my face . . .

David: Yeah.

Corey: . . . during the video. It's really nice that someone's validating it. And like I said before, I've been very shocked that this much of detailed information is coming through **Tompkins**.

David: I think it might be hard for people watching this show to really understand how real all of this is. This is not entertainment. It's not science fiction. And the things that have happened to you are percolating through the entire space program infrastructure.

Corey: Correct.

David: So when he said that stars are alive, how do you respond to that?

Corey: When I looked at the smart glass pad, there were different groups that had more esoteric ideas about things, and other groups that had more scientific pragmatic ideas about the star and the nature of the star.

And I did see reports that stars and planets, they believed they were alive. But I didn't see any

information about the scientific part that was at the top of the briefing in the smart glass pad about stars being alive.

David: Well, you've read enough of The Law of One to see that there's a lot of crossover between The Law of One and what you experienced in the space program, correct?

Corey: Right. Right.

David: And The Law of One says that stars are alive.

Corey: Right.

David: So that's a nice point of correlation we have there.

Corey: It is.

David: When he's getting into this idea of the Sun sneezing, he seems to think that the beings in the sphere are working against the Sun, that they don't like what the Sun is going to do. I'm not sure I agree with him on that particular point. What's your thoughts?

Corey: Well, what was interesting is that in the briefings, “solar sneeze” is the terminology that was used. So that got my attention.

David: It was?

Corey: Yes.

David: Really?

Corey: Yeah. That was one of the descriptions. They expected the Sun “to sneeze”. So that got my attention.

David: Now, I would imagine that if people were looking at this from a physical level, they may see it only as a catastrophe if they're not understanding dimensional shift.

What are your thoughts on that?

Corey: Right. And within the space programs, you have different ideas about what is going to occur when a solar event happens. Some of them are expecting what is referred to as a “spiritual harvest”.

Some of them just expect maybe a decade or two of having to rebuild our infrastructure that we will lose, and some of them expect it to be like an extinction-level event. So not everyone agrees on what's going to happen, but they all agree that there is going to be some sort of a "solar sneeze".

David: Well, it, again, is just so remarkable that what he's describing about what these spheres are doing is exactly what you've been telling us on this show.

Corey: Right. And he was saying that there was some sort of an adversarial relationship between the sphere and the Sun, when the information I received was that these spheres are here to, I guess, baffle the energy until we are ready to have a full hit.

David: So they're actually helping the Sun do what it's doing, but do it maybe more precisely or at the right time.

Corey: Right. They're helping the Sun go through a transition.

David: When he said that there are 2,000 extraterrestrials inside this sphere and that there's different civilizations in there, how do you feel about that part of his statement?

Corey: Well, some of the intel on these different spheres was that they were sort of like confederations from hundreds of different planets.

David: Oh!

Corey: I didn't hear that there were 2,000. I didn't hear that precise information.

David: But he said it, so he must have gotten it from somewhere.

Corey: Right. He may have been briefed on one of those crafts like you saw come in, or you were told that came in, in the '80s.

David: Right.

Corey: And that might have been one of them that was full of hundreds or thousands of different species.

David: From what you've described before, it didn't sound like these guys would be able to get that much specific information about who's inside the sphere, since the spheres wouldn't even talk to the SSP.

Corey: Right. And like I said, when they first came in, they thought it was the return of the Sumerian gods. A lot of them were real excited. And since then, during the time period when they didn't know who was in the spheres or what the spheres were for, they were probably speculating quite a bit.

David: So another interesting thing that he said here was that these spheres had two purposes, that one of the purposes was to monitor the activity of the Sun, and this sneeze that's going to happen, and that the other had to do with Reptilians, and making sure that they didn't take too much advantage of us.

So once again, I mean, how did you react when he said that?

Corey: It is very satisfying to hear someone who is credentialed and has had a background like **Tompkins** has had come out and validate what I've been saying.

David: It would appear that he and his people are well aware of the Draco problem. He talked about it with Nazi Germany.

Corey: Yeah.

David: So he's now saying a direct link between the spheres and the defeat of the Draco.

Corey: Right.

David: So, again, it's as if somebody is either watching our show and passing this to him, or this is real. It's like you only really have two choices.

Corey: Right. Right. And what you've said is exactly what I've been saying. The spheres have come here not to defeat the Reptilians, but to create an environment to where we can clean up our own mess.

David: Right.

Corey: And they're here to mitigate the explosive energies that are now and in the future will be coming from the Sun. So that's right on the money.

David: Next, we're going to see **Tompkins** in a discussion about a think tank that he worked in, and a very humorous event involving an extraterrestrial craft. So let's watch.

* * * * *

UNCONVENTIONAL PROPULSION SCHEMES [editing note, the following is missing a lot of the original pictures]

William Tompkins: What was the main mission, and what did people do in this Douglas think tank? And one of the areas that was most important was a thing that they came out with and that's "Unconventional Propulsion Schemes". Oh, my gosh.

And so everybody got to work on that, and everybody tries to come up with a different method of propulsion. And so that's this one. [**Tompkins** holds up a thick set of documents bound by a large clasp.]

And it does get into updating things that we thought were futuristic, but what it really comes down to is a knowledge of different missions that need to be implemented.

And so along with information to put into this, the Vice President of Engineering also made me Disseminator of Space Research, whatever that is. Okay?

So then I get stuck with all of the incoming mail that's coming from the different associate organizations to Douglas. And some of the interesting things that come in is a group of people down at the beach, which is only a few blocks away, were out on Sunday afternoon, and one of the managers at Douglas, engineering managers, was there with his family.

And so over at Northrop, Jack Northrop had been building his new flying wings. And he keeps getting them bigger and bigger. And he threw out the old piston engine things and put the new jet engines in.

And so there's a guy by the name of Max Stanley, who's the chief test pilot for Northrop.

And they're late on their flight schedules on the B-49 Flying Wing bomber.

So it's like 11:00, a beautiful day, and Max gets there, and he fires the thing up and he takes off, and the

runway's half what it should be because he pulls the fence down almost every time at the end of the runway. They lay the fence down now.

Anyway, he flies south, turns out over the ocean, and now flies north like he's going to go out to Edwards Air Force Base out in the desert.

So, of course, that means he's go to go up the beach, past the beach, at Santa Monica. And a lot of people have seen the test flight flights going and coming.

And so inside of the cockpit at that time, with Max and his flight test engineer, just the two of them, the flight test says, "Hey, Max, what's that?"

And so this little UFO comes in, flies right next to them – right off the wing – okay? 10-foot off the wing.

And he's giving Max the finger. So he proceeds, in front of all these people - all the beach is full of people – he moves over in front of Max, so now Max has got him right . . . 10 feet from his windshield, okay?

And he flips over backwards and goes around, comes out underneath, comes up, and twists over, gives him another finger, and goes back again.

Then he flies out off the wing and makes a turn and goes around the wing. He did this for about 10 minutes.

By now, everybody on the beach can see this going on because they're only at 6,000 feet.

And so the Douglas manager that was on the beach at the time and saw this, of course, he knew what was going on. And anyway, he wrote me a letter and described this as one of the inputs about local stuff on UFOs.

So I got two or three of these every week from different areas, and some of them were from the airbase test areas.

And so we got a lot of data, and our data then became part of the information that goes into this document.

And so then different people in the 200-man secret tank have different assignments from what's in here. [Holding up the thick collection of documents] And that's sort of the way that this thing operated.

* * * * *

David: All right. So there he is describing this document on unconventional flying objects and unconventional propulsion.

In his book, he goes into a lot of detail about that, a lot more than we saw here, and said that it was this focal point that the birth of the space program came out of.

Did you ever see any of those old documents in the smart glass pads?

Corey: There were a lot that were just so mundane to go through that I just did not look at them. But there were . . . A lot of the time when you would pull up something on the smart glass pad, it would be documents from the '40s, '50s, '60s, and it was just presented as . . . it looked like a document.

David: So he mentions that the PM 624 document was investigating different types of propulsion systems for different needs that would evolve into the space program. It's really amazing to get this kind of history. So what do you think those needs were that they were looking at?

Corey: Well, it would depend. If there was a craft that was a resupply vessel, it's not going to need to necessarily, unless it's traveling with a carrier group, it's not going to need to keep up with a lot of these vessels that travel interstellarly if they're just going to work here in the solar system.

You know, they have different types of propulsion. They have temporal drives, torsion drives, electromagnetic just propulsion. And these come from different non-terrestrial groups.

Some of them are so advanced that they use temporal drives that will, no matter where they are in time and space, [**Corey** snaps his fingers] they can be here and now.

So if they get their hands on some of those, yeah, they're going to want to use that to maybe put that

into their ICC program [Interplanetary Corporate Conglomerate] to where they have the newest, most advanced technology, and then disseminate some of that information to the other programs, or provide the technology to upgrade vessels that are already out there.

David: Whereas if you have a guy who's like a truck driver and he's doing a shuttle bus or something, you don't want him to have any extraordinary capability.

Corey: Right.

David: If he tried to break away or something, you don't want him to be able to escape.

Corey: Right. Yeah. And usually, in most of these craft, they have a return-to-home feature, that if someone tries to go rogue, they can push a button and the vessel just comes back to where it left . . . from where it left.

David: So it was kind of humorous to hear this idea of a UFO circling around a plane and giving him the finger. Now, I guess you and I . . . Neither of us are really clear about was there an occupant who actually extended his middle finger?

Corey: That's what it sounded like to me.

David: Or appropriate appendage.

Corey: Yeah.

David: It did sound like that.

Corey: Yeah. Normally, I would say that this was one of the Secret Space Program pilots. They are a breed of their own. If you remember the "Top Gun" movies, how cocky and arrogant and self-assured these people are, multiply that times 100 because they're the best of the best. They're flying in space. They're flying things that no one's even allowed to know about.

David: The time frame that he mentions of 1955 and working at Douglas Aircraft – how far along was the American side of this as of that year?

Corey: In 1955, I don't think that they were that developed. This sounds like it could also possibly be one of the German breakaway vessels, because that's during the time period when these German breakaway vessels were showing their selves.

David: Are there any German craft that would have clear glass enough that the pilot could be seen inside like that?

Corey: I'm sure there were. Most of the craft that I was privy to that the Germans had, they were using imaging systems that . . . the outside was totally solid and they could see 360 degrees and up and down from the inside through the imaging systems that they had on the outside of the craft.

David: Hm. All right. Well, now we have more of **Tompkins'** amazing testimony regarding the legendary father of NASA, the German expatriate scientist, Wernher von Braun. Let's take a look.

* * * * *

WERNHER VON BRAUN

William Tompkins: I have to say, Douglas Engineering were the best guys I ever worked with. They were the princes.

Douglas was known for the surfers. So when von Braun came out to Douglas to find out why he lost the contract for the IRBM's and wanted to know who the hell did it and who's the guy **Tompkins** . . .

Anyway, he comes out. And so at that time we had like 900, 800 drafting boards on one floor and about 600 down below. And we were up on the second floor.

So when they brought . . . The Vice President of Engineering brought von Braun up to the second floor. I knew he was coming so I went running over to a drafting board on a stool. And so I pretended to be drawing, but everybody knew I wasn't.

And so he had to walk all through all of these 800 drafting boards to get over to **Tompkins** out in the middle here. And I did it on purpose. And because he continued to get feedbacks from different subcontractors when he's down at his facility about that damn surfer from California, and he wanted to meet that surfer.

But we then had probably 40 of these [He holds up several of the documents] in a package, and so he wanted to know all how we did everything.

And there was one of these which was a really nice one, sort of derogatory, and it was about the

German V-2.

And so the secretary brought that over and handed it to me while he's there and wanted me to tell her how I should handle it. And it pretty well broke up engineering.

But the point was that he did come out because he really wanted to find out how this group of guys that were really just plain surfers – doing grabs and whatever . . . And he went away with a tail between his legs. It worked good.

* * * * *

David: So is it common for there to be this kind of joking around inside a facility like this, where even somebody as high-ranking as von Braun comes in and then is shown an insulting illustration or something about his own work?

Corey: A lot of these engineers are characters, but that was pretty brazen if you ask me.

David: Yeah. I mean, I would imagine in some of the stuff you described that the climate is so oppressive that the idea of trying to thumb a nose at your superiors is just not ever going to be advisable.

Corey: Yeah, it's not advisable in any situation. Ha, ha.

David: Ha, ha, ha. All right. Well, that's all the time we have for in this episode. I hope you've had fun seeing this all unfold. It's really amazing to go back and look at the amount of confirmation that we're getting on giant spheres, solar system lockdown, what's really going on here with the agenda of the spheres, the solar sneeze, the Draco.

A lot of stuff has been covered here. This is “[Cosmic Disclosure](#)”. I'm your host, **David Wilcock**, and I think you for watching.

[Cosmic Disclosure: Exploitation of E.T. Technology with Clifford Stone](#)

Season 6, Episode 6

David Wilcock: All right. Welcome back to “[Cosmic Disclosure](#)”. I'm your host, **David Wilcock**. I'm here with **Corey Goode**. And in this episode, we are doing a special investigation into Sergeant **Clifford Stone**.

I was fortunate enough to meet him at the Disclosure Project event in May 2001 when he first came forward as a member of a UFO crash retrieval team and someone who has gotten his hands dirty in terms of actually releasing documents through the Freedom of Information Act that had never before seen the light of day.

So what we're going to do now is show you some footage of our interview with Stone. And then we're going to have some comments on it.

In this first round you're going to hear him describing two of the classified programs with the code names that he was involved with involving crash retrieval and his work in getting those documents out. Let's take a look.

* * * * *

GETTING CONFIRMATION

Clifford Stone: I had to go on a search for the documentation to kind of sort of validate me to my family. They were there. My wife knows more about it than my kids do. But, you know, I'll be criticized by my kids because I wasn't there for that game. I wasn't there for this social event – things of this sort.

And see, I was a clerk. I wasn't supposed to do all this stuff. I wasn't supposed to go to the field all the time. They did not know what went on.

Now, my wife did, because, like I said before, she was there from the beginning. But I initially wanted to go ahead and validate myself. I wanted to validate myself to my family.

But also towards the end of the time that I was getting out, I saw all the horrible things that were happening to people who were witnesses of UFOs. I saw the people who were ridiculed. I saw the people who lost their families because they just happened to be a witness to an event of high

strangeness.

I have known people who have killed themselves. I know people who have lost their jobs. I know people who have become recluses because society in which they live rejected them because they happened to be involved in an event of high strangeness, and they made the big mistake of talking about it.



And since at least 1973, Operation Ridicule – and that's what I call it, because it really is a directed effort by our government and other governments of the world to ridicule ANYONE who comes out and talks about having ANYTHING to do with UFOs.

And you're even encouraged in the military if you have an event, or if you're an airline pilot, DON'T TALK. It will destroy your career. It will ultimately destroy your life.

So the whole situation is, I had to try to get some confirmation that it's okay to have these incidents, these events to occur in your life. And if I could get that confirmation officially from the record, it'd go a long way to help people.

I think the most amazing documents that I have unearthed, and I have to put them together, is the

confirmation of Moon Dust and Blue Fly as they pertain to objects of unknown origin.

Moon Dust is the overall field exploitation program for only two items – objects of non-US origin that survive re-entry into the Earth's atmosphere. And, of course, these would have an intelligence value to the intelligence community to determine what the state of technology is that went in to that particular craft from a potentially hostile government to the U.S.

The other item is objects of unknown origin. Within unknown origins, UFOs fall into play there. Okay.

These documents went ahead and show where we recovered various objects of unknown origin. And we brought them back to the states, and we were looking at them.

As a matter of fact, the NSA even had what was called a fractology lab where they would look at fragments.

Now there was a great debate between the intelligence community and NASA, because NASA felt that they should have total control.

The CIA made it quite clear that while NASA sometimes works hand in hand with the CIA, NASA is primarily a scientific endeavor.

Covert operations of an intelligence nature lies within the intelligence community.

So initially all these objects would go to the intelligence side of the house. If NASA was to get an object of unknown origin, they were without question to turn it over to various agencies within the intelligence community.

Then after the intelligence community did what they could with it, they would turn it back over to NASA for NASA to turn it over to the launching authority of the country that put the spacecraft up there to begin with.

But here again, if it was an object of unknown origin and it turned out not to be of this world, NASA would not get anything back on it. But NASA did have debris of unknown origin that was within their

fractology lab.

1985, the name Moon Dust and Blue Fly – and Blue Fly was the actual field teams that went out to the field to do the covert extraction and also be there in case there was a need for a cover story, or what have you, and get it back to a safe haven area in a rear echelon area and ultimately back to facilities in the United States.

Thank you for forwarding the undated response (inclosure 1) the U.S. Air Force sent you concerning my letter of January 4, 1993. However, I still find their answers to be evasive of the issues I raise and once again untruthful. Please permit me to illustrate.

1. "The unit with responsibility for maintaining these teams was located at Fort Belvoir, Virginia. As the occasion never arose to use these air defense teams, the mission was assigned to Headquarters, United States Air Force in 1957 and expanded to include the following peace-time functions: a) Unidentified Flying Objects (UFOs), to investigate reliably reported UFOs within the United States; b) Project MOON DUST, to recover objects and debris from space vehicles that survived re-entry from space to earth; c) Operation BLUE FLY, to expeditiously retrieve downed Soviet Bloc equipment."

REBUTTAL: "This unit" was created as a result of Air Defense Regulation 24-4, dated January 3, 1953 and was known as the 4602d Air Intelligence Service Squadron. "This unit" was given the responsibility, "to investigate reliably reported UFOs within the United States" under Air Force Regulation 200-2 dated August 26, 1953. Therefore, this requirement existed long before 1957. It existed as of August 26, 1953.

So I went ahead and I did a 178 page report entitled "Operation Blue Fly Research Project Report to Congress".

And I went ahead and I sent it to 27 various members of Congress – the Senate and the House.

And our senator here, he took it to several other senators that were involved in the Armed Services Committee that was holding hearings actually on some – and remember, this is '94. This is when the big questions about what really happened here at Roswell came into play.

Clifford E. Stone
Director
Operation Blue Fly Research Project
1421 East Tilden
Roswell, New Mexico 88201-7955

Phone: (505) 625-0920

December 27, 1992

Senator Bingaman,

Thank you for your most recent letter of December 14, 1992.

interest of the people.

The Air Force is trying very hard to hold something back about these missions. While it may not be the recovery of space craft from some other world, it could very well be a violation of international law. Therefore, Congress must be made aware of all the facts and not just what the various agencies wish them to know.

Senator, I have taken great pains to remove this from a UFO issue and place in a more down to earth issue. In short, Project MOON DUST and Operation BLUE FLY did/does exist. Now the U.S. Air Force would have us to believe that there was nothing to these two missions, while, at the same time maintaining the any information on these two missions are highly classified and not releaseable. Why??

I hope to hear from your office soon in response to this letter and hopefully the Air Force will be much more responsive this time around.

Some of the people, behind closed doors - because UFOs is not a good subject to get messed up with if you're an elected official – asked some people about, “Whoa, wait a minute. They did recoveries. This document shows that. We need to know what really is going on.”

In short, I know for a fact that report that I did in '94 caused them to expose the National Reconnaissance Organization.

And the reason they had to expose it was real simple. They wanted Congress to understand that, “Well, you know, we have highly classified reconnaissance activities that involve highly sophisticated and highly classified manned, – I'm going to say it – unmanned – manned and unmanned satellites.

And there aren't supposed to be any manned satellites, but there are.

And the situation is, with this being the case, if they fall back to Earth, it is imperative that we get them before any potential enemy of the United States get them or any potential future enemy of the United States gets them. And we must get them and get them back here to the States or to a safe haven area.

So they started talking about the nice activities on a very low key, but at least it got the exposure that it needed.

Then, of course, little demons like me went in and started to ask, “What more do you have on the NRO?”

* * * * *

David Wilcock: All right. So this is a little bit more of a down-to-earth-type of UFOlogy than some of the stuff we talk about up in space, but still a very important part of what's being done in order to keep the UFO coverup going.

In the clip he described Moon Dust as the umbrella program that is essentially looking at threats to the United States. Blue Fly is the actual team.

What's the amount of prevalence that you think is happening with these types of programs? How many retrievals are being done in, let's say, a given year?

Corey Goode: And I haven't seen information for some time on . . . so I don't know currently, but back before the time of about 1986, they were occurring on a semi-regular basis. I don't know . . . You know, there'd be like maybe 4 to 12 in a year.

David: Hmm. When we're looking at a guy like Stone involved in something like this, first of all, do you feel that there are a large number of people that were doing the kind of thing that he was doing and they're deployed at different times?

Corey: Yeah. They try to deploy the same groups. Sometimes there will be . . . They'll send other military assets out to secure the location, but they'll form a perimeter far away so they can't see what they're securing. And then they'll bring in one of these other teams that specialize in retrievals.

David: And we know that Stone's work is intuitively interfacing with the beings, if they're still alive in the crash. And in some of the other footage that we've seen, he gets very upset about that.

Is it normal that the extraterrestrials operating in our airspace are going to have a telepathic ability like that?

Corey: Yes, that's actually quite common, and it's a lot easier to communicate that way than verbally. If you have a species that's from another star system, they come here, even if . . . You know, they'd have to study us and then know all the nuances of our language to really communicate.

It's really hard to misunderstand when you're interfacing.

David: He described the awesome amount of effort that was put in place to ridicule anyone who talks about UFOs in any way at all. And as far as you know, is this a program that was designed from the very, very beginning of the UFO phenomenon?

Corey: Yes, and it's a documentation going back from . . . to the very beginning of when we see that the government was investigating UFOs. It's very clear that from the beginning they wanted to ridicule anyone, no matter how professional they were, that had reported seeing a UFO or their occupants.

David: How do you think that something like this could have been successful, given the awesome level of interest in being visited by people from another world?

Corey: Well, in the '50s, if you look at the news footage of them interviewing contactees or people that saw UFOs, it was . . . the way they shot it, the way . . . they made the people look ridiculous. So the mainstream doesn't have as large of an interest in this.

So if the subject comes up, they'll listen and then move on with their day, because they're not taking it seriously because the media is not.

David: Well, I think that may be changing a lot more now as media becomes increasingly decentralized. It would certainly appear that the media is an opinion maker. And people have a very serious fear of ridicule.

So do you think that this fear of ridicule was effective enough to stop many people who did see things from coming forward at all?

Corey: Well, people that had something to lose. You know, like he mentioned pilots – people that worked in various professional fields where they had put a lot of time and effort into getting an education or certifications – those people . . . They have a lot to lose, so they'll talk quietly amongst themselves, but they're not going to talk openly.

David: Do you think that the US government always saw UFOs as a threat, or do you think that they were aware that some of this was completely benign, but they chose to have a military type of reaction to it anyway?

Corey: Well, whether it was a positive or a negative group visiting, it didn't matter. Both of them threatened the status quo, which allowed them to control the Earth.

So no matter which polarity these beings are, they have us programmed to believe a certain way. That's going to change the paradigm, and they're going to lose their grip.

David: Do you feel to some degree that there's a generational gap going on here in which people who grew up in the era of media ridicule and indoctrination still have this fear of being ostracized from the group if they get into this whereas younger people are not seeing that anymore and therefore they're far more open-minded?

Corey: Well, younger people are spending most of their time on social media where you don't have the mainstream media delivering news that's approved from the government.

David: Right.

Corey: So they're getting a much wider spectrum of information than people used to, so . . . and you see the consciousness expanding of the younger people.

David: Well, I don't know about where you are in Dallas, Texas, but, **Corey**, I have never met someone who was not interested in UFOs when I brought it up. Never. And it could be just any random person.

They ask me what I do – the dreaded for words, “What do you do?” Have you ever experienced people actually having problems with it? I mean, it seems very rare to me.

Corey: Yeah, it depends, I guess, on your location, but in the Dallas area, if you talk about aliens and UFOs, people will humor you, kind of watch, look at you. But you can see on their face that they're just like ready for the conversation to end so they can walk away.

David: Really?

Corey: Yeah.

David: When these programs eventually collapse, what do you think those types of people are going to have happen to them?

Corey: First, they'll probably go into denial, and then acceptance just like the steps of grieving. They've got to change their paradigm. All of their belief systems now they've got to hold up and compare to the new information. That's not comfortable for anyone.

David: All right. Well, what we're going to go to now is an interview with Stone – part of our interview with him – where he describes a very, very intriguing event that took place during the Vietnam War. This is high strangeness, highly interesting.

And then after we have this footage, we will be discussing the implications of this very strange story. So without further ado, let's check it out.

* * * * *

ET TUNNELS IN VIETNAM

Clifford Stone: Now with being assigned to Vietnam, I wind up getting assigned to Tay Ninh. And when I get there, once again, I'm back in communications, NBC, all that good stuff.

I was notorious for a lot of times I'd go outside of the perimeter. You wasn't supposed to do that.

I went ahead and I went out one night, and when I went out, there was a helicopter there. And the guy I always called the Colonel, he's there, and he says, "Why are you late? We've been waiting for you."

And I said, "Late? How the heck did you even know I was coming out? I didn't even know it."

Anyhow, we get on the helicopter, and we take off. And we're flying towards Nui Ba Den. And we're getting, you know, maybe 2/3rds of the way up.

Now, the problem is the old adage has always been we had the top of Nui Ba Den, and we have the base. The NVA and VC have the center. And we know that they had tunnels and all that other good stuff there.

So when we landed, there was already other military personnel there, and they were heading up on a tunnel.

We were told that the enemy was working . . . Well, I can even tell you what it was – bubonic plague. They were working on a biological military-type weapon, bubonic plague, that they were going to try to use against US forces there. And we had to go ahead and destroy the facility.

So there's this tunnel. And no one questioned . . . I mean, it was a tunnel. No one questioned the fact that it was V-shaped. It wasn't like a jagged hole in the wall of the mountain, but it was V-shaped.



Now, you had the rocks on the top and all that. The ground on the bottom was totally smooth.

Once again, we didn't question it. And I don't know whether we thought, "Well, maybe the VC could have done something with it or . . . ", it just didn't come into play. No one questioned it at all.

We start to go back into the tunnel. We get several hundred feet in the tunnel, and we can still radio back and talk to the people that's on the outside.

Now, we get to one point, and it's like a line in the sand, so to speak, because on this side you can talk, you can hear, clearly on the radio. You step across that, now you can't.

So we went ahead and left a radio there, and we set up a field telephone, 312, and we left a radio telephone operator right there. And he was to communicate with the folks on the outside.

And we went on into the cave. I don't know how many hundreds of feet we went on into the cave, but

at some point, it got to the point where we couldn't talk on that 312 calling him back. It just wouldn't work. Nothing was wrong with the batteries or nothing, but we just couldn't carry on a conversation.

We go ahead. We go further into the cave. Now, as we closer, we start to see it's starting to get lighter, and we can't identify the light source.

Then we stepped into this big, open area inside the cave. When we stop in there, we go ahead and see what appears to be a huge laboratory.



And on the other side, there's this huge . . . I call it a window. And we could see some of our troops outside that window that appeared like they were just walking on air, because there's no ground there.

You could see the night sky perfect – everything, no problem. And you're wondering, okay, what's going on?

Now, it's hard to explain, but you're not seeing them silhouetted or, I mean, you're seeing it. It's dark, but you're seeing them.

After we couldn't call back, we had a person that became the runner, and he went back to tell the radio telephone operator. So there was a little delay in that, getting back to say, "Hey, tell these people to do that."

But we could see them, and we went ahead and asked, are these people out there? And they had them do certain things so we could tell that these were the people.

And we asked them, "Can you see anything out of the ordinary?"

And, "No, but everyone is looking towards the sky."

And we went, "No, no, don't look towards the sky. Look towards the ground. Is there anything out of the ordinary on the ground?"

No one saw anything out of the ordinary. And, of course, we see them when we look to the ground. We tell them to do specific things so we can tell that they're our troops. We went ahead and watched that, and we knew, "Hey, this is happening in real time."

This isn't a screen and they're heading up on pictures, and it's just unusual to us because it's a technology that we're not familiar with.

Now, to us, it was inside the cave. We were witnessing all this.

The ones on the outside of the cave, nothing was unusual. But we told the ones on the outside of the cave, "Take your trenching tools and dig a couple scoops of earth. Let's see what happens."

We could see inside the cave where they'd go ahead, put their trenching tools into the ground, but it was like they were going into clear air. But when they picked up the trenching tool and tossed the earth that was on the trenching tool, we could see it go through the air, but when it hit the ground, it would just be like it would just totally disappear again.

I guess I can say I found it fascinating. But at the same time, . . . [there was] no explanation on why it's going on. I mean, we were trying to think of a plausible explanation. Is there cameras on the outside?

This wasn't like a screen. This was like a window, and it covered the whole side. And it was not like a screen at all, like a projection screen or what today we have with our TVs, flat-screen TV. It was nothing like that at all.

All of a sudden, we start seeing once again, a typical Grey. Someone asked me to try to describe them, because I really can't, because I only know what you'd call 'typical' Greys by the large heads, small, spindly bodies and the large eyes. They didn't say anything.

But they came up, and people started to shoot. And I was trying to tell people to “cease fire, cease fire.” Because by this time, I already knew we wasn't alone there.



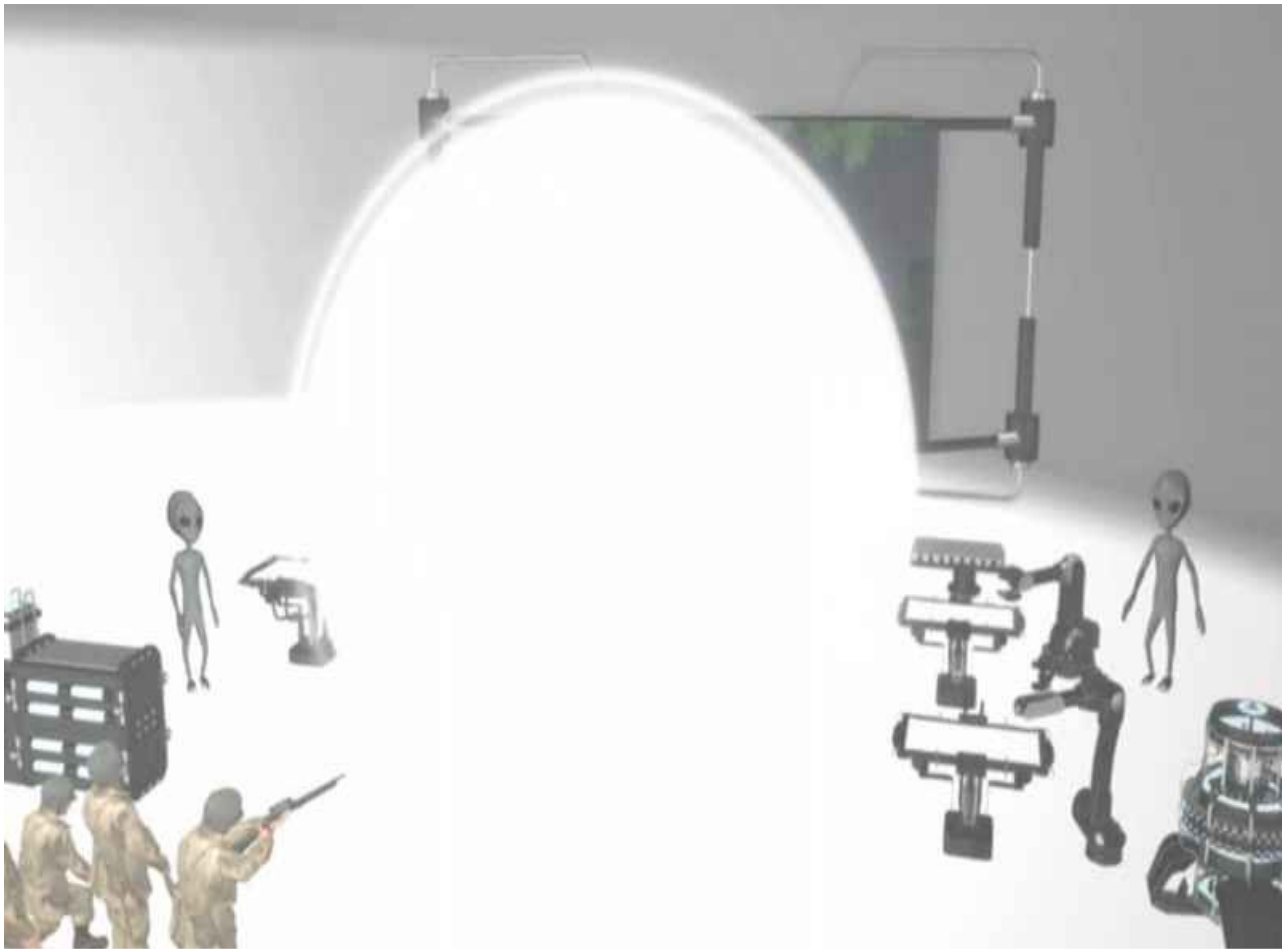

And when I was telling them to cease fire, it didn't happen. So what I did, I went ahead and I asked them, or I was still asking them, and all of a sudden it got white, like there was a glow to it.

But it was like you were in the middle of a glass of milk. And it wasn't fluid or anything. You could breathe easily, all that good stuff, but you can hold your hand up like this in front of your face, and you couldn't see it, because it was just a, shall I say, fluorescent white that surrounded everyone.

And I could still hear the shooting going around, and all of a sudden, I got something . . . My eye was very painful. And I remember trying to grab a hold of my eye, and I went down.

And I remember it was agonizing pain. And after I went down, that was the last thing I remembered.

I remember hearing a voice saying that they needed to let my people take care of me, and another voice saying, "No, there's no way that they can fix this. We need to take care of this person or he will lose his left eye."

Later on, I woke up. I was outside of the cave. And I looked up at the captain, or the guy I always called the Major, or the Colonel, and I said, "How did I get out here? How did I get out here?"

And he told me, "Well, we don't know. One moment you wasn't there, then all of a sudden you're there."

Then he even asked me, "What happened to your eye?"

I says, "I don't know."

And they only had . . . and the medic said it had been worked on, but it was our people that put the patch on it. And for over a week, I wore that.

Official story was that there was a bug that sprayed a spray into my eye and sprayed it and hit the corona of the eye and cut it all the way across.

And I'm going to tell you right now, I know no bug that can do that, even in the tropics or any place. And I have talked and asked other people, "What type of bug could do that?"

And I've had experts tell me there is no bug that can do that.

But I had no problem. I wear reading glasses, but I have no problem with my sight.

* * * * *

David: All right. So in a case like Stone's, it appears that here's a guy who is actually getting extraterrestrial contact all throughout his life. Do you think that there are certain people who are receiving weird events like this throughout their lives for some greater reason of some kind?

Corey: Absolutely. And military intelligence knows who are having these experiences. They monitor them.

David: How do they know?

Corey: Well, they're tracking all of these different craft flying around. If a craft is visiting a certain area, they will go and usually re-abduct the people to find out what occurred for gathering intelligence.

So yes, there are a large number of people that have experiences. Many don't remember them, but they are watched.

David: So what do you think is the endgame of a group like the Greys having this large laboratory inside a strange cave in Vietnam? What might they be doing in there?

Corey: Well, they're obviously doing some sort of either examinations on the locals or some sort of science that they want to keep hidden. So a perfect way to hide it is to put it in that cave.

But it's in the middle of a war zone. It would be very nice to know what type of a lab it was, what was going on in the area to be able to determine what this group of extraterrestrials were doing with this lab.

David: Do you think that it's possible that they would have an interest in wars and want to monitor wars for some specific purpose?

Corey: Well, sure. There's a number of different non-terrestrials that monitor our wars. But a lot of the times, they have assets, human assets, people that they have abducted or have had contact with, and they will keep those assets safe. They'll track them and monitor them during a conflict.

David: Do you think it's common for there to be bases that extraterrestrials have, where you actually could just walk into maybe a slightly unusually perfect-looking cave or something?

Corey: Well, most likely, the mouth of the cave had a hologram or something across it that hid it. It would be very unusual for them to have just a big, open, strangely-shaped entrance that's going to attract attention, unless it's some sort of honey trap.

David: Right. So that could have been something where they knew Stone was going to be there, and maybe they turned the hologram off so that he would go into that cave or something.

Corey: Possibly, yeah.

David: What kind of technology could allow them to be able to look through soil as if it wasn't even there, like it's just a pane of glass?

Corey: They have different imaging technologies. They could most likely even look through that window and see their own planet if they wanted to. To us, it's magic.

David: Well, it appears that the dirt was under some control, because he said that when they dug the dirt out, it was visible. And then when it was thrown, it was visible. But as soon as it hit the ground, it became invisible again.

Corey: Right.

David: Is there something they could do to the matter state of the soil maybe to make it so it's not visible while it's on the ground?

Corey: Well, they're not affecting the matter. What they're doing is . . . the technology is just like a filter. It's filtering out the information being delivered to the technology about the soil and all of that.

David: And when he said that he saw a huge lab, he didn't get into detail about what the lab looked like. But if this was a lab that was run by Grey-type extraterrestrials, would he have been seeing something that would look pretty different than any normal lab on Earth?

Corey: You would know immediately that this was not a terrestrial lab run by human beings. And also, remember that after they got a certain distance inside the cave, they hit a dampening field of sorts to where their radios and field phones didn't work, you know, with cables run even.

David: Right. So that's some sort of electromagnetic scramble effect maybe?

Corey: Yeah. I've just heard them called 'dampening fields' that prevent any type of radio waves and that kind of thing from penetrating.

David: Okay. So what do you think was happening when he and his fellow soldiers got surrounded by this marshmallow-type fluorescent energy that they couldn't see one foot (30cm) through? What do you think was going on there?

Corey: It was a defensive technology. I've heard of similar things to where people will go into a craft or somewhere where they're not supposed to be, and then there's a big flash of light that lasts . . . it lasts longer than a flash. It's like . . . it stays. It comes on and stays.

And it sounds like he was teleported out of there.

David: Is this something that these Greys could do with their own consciousness? Or do they have a technology that would require it to be used that way?

Corey: Well, I read reports that they could defend themselves without carrying weapons. So this was either something that was implanted in them technology-wise, or it's through their consciousness.

David: There does seem to be some benevolence in these beings. They cared about his eye. So what kind of technology do you think they might have had to heal his eye? It seems like he got hit by a bullet or something maybe? We're not really sure.

Corey: Yeah. From what I've read in the smart glass pads, the human body is very easy to manipulate and repair. So they have to have some sort of tissue regeneration, nerve regeneration, technology.

David: Is a story as ridiculous as an insect hitting his eye . . . Is that a common thing for the military to do when they're faced with this stuff?

Corey: Oh, yeah. They have twisted ankles, any type of injury, there are all kinds of explanations, 'official explanations', they'll put out.

David: So with a guy like Stone having experience of this nature, and we talked a little earlier about the idea of people having these experiences throughout their life and being monitored, do the extraterrestrials have the ability to control who would be able to find a facility like this?

In other words, was he allowed to see this, and was it because he was a certain person? Or are there cases of just ordinary people that could randomly find something like this and stumble in on?

Corey: I think it's very rare for someone to stumble across something like this. And when he arrived, it had already been found. So he was coming up to a situation to where they'd already found something, and they were sending him in later.

David: Right.

Corey: And as I stated before, most likely before it was found, either there was something covering the entrance . . . there was most likely something covering the entrance, and either that technology failed or was turned off for a purpose.

David: Do you think that the Greys already knew that they were in there when the Greys showed themselves?

Corey: Yes. They probably came because some sort of an alarm was set off.

David: Do you think that the Greys are confident enough in their ability to thwart human machine-gun type of artillery that they could just walk right up even though these guys are fully armed and might be shocked by what they're seeing?

Corey: Yes. They will walk right through gunfire or towards people firing at them.

David: So it really poses no threat to them at all.

Corey: No threat whatsoever when they have the proper technology. There have been plenty of instances of non-terrestrials, including Greys, being shot by military.

David: Oh, there are?

Corey: Yeah.

David: Okay. So it's some kind of technology that they're using?

Corey: Most likely a technology, consciousness, or a mixture of both.

David: One of the things that's very strange that this reminds me of was a guy I knew who had been in touch with one of the top 90 people in the Cabal, so he said.

And he was given briefings on various extraterrestrial technology that had been found. And he described a particular river – I believe it's the Potomac River around Washington, DC – and that there was an egg that was found inside that was very metallic. It was deep inside the sand.

And they couldn't open it for a long time, but it looked very exotic.

And eventually, they realized a dog whistle would open it when they blew the dog whistle. And this thing goes, “Psst”, like this, and it popped open.

And what it had inside of it was a whole series of actual Polaroid-type photographs of major events that

had taken place in that river, apparently including a military blockade where a chain had been pulled across the river to stop ships from getting in.

So this was just like a little drone device that again seems to suggest that certain extraterrestrials are very keen on observing our wars and our history and seeing what takes place and when it took place.

Corey: Yes, and there are small drones that go around and observe people in situations that you cannot see with the naked eye, just like in the movie “They Live”. You know, when he looks up and sees a drone flying around, that type of technology is in use by the non-terrestrials.

David: All right, well, this has been a really fascinating investigation. Stone is obviously one of the most impressive whistleblowers because he's coming at us from the perspective of the crash retrievals like Roswell, being there and doing it multiple times.

This is a fascinating investigation. This is “[Cosmic Disclosure](#)”. I'm **David Wilcock** here with **Corey Goode** and our special guest Sergeant **Clifford** Stone, and I thank you for watching.

[Cosmic Disclosure: Your Guide to ETs with Clifford Stone](#)

Season 6, Episode 7

David Wilcock: All right, welcome back to “[Cosmic Disclosure](#)”. I'm your host, **David Wilcock** and I'm here with **Corey Goode**. And we are now into our final section of material from the UFO crash retrieval expert, the legendary Sergeant **Clifford** Stone.

What we're about to see here is a very intriguing piece of the interview in which Stone is describing his work with the medical field manual for a total of 57 different varieties of extraterrestrial that he may encounter, which they lovingly called “the Heinz 57”. Let's check it out.

FIRST AID FOR ETs

Clifford Stone: There were several books, but this one book, the intent of it was, when we went out to a site, one person had control of that book. And that one person had a medical background. I can't say a doctor or anything like that.

But the intent of that was to have that book so we would have an understanding of first aid to render any of the entities that we might come up on. That was the whole purpose of that.

I was never supposed to see that book, but because of some other people, intuitive people – I'll put it that way because they knew that there was more of a reason for me being there than just being a member of the team.

And, you know, I didn't go out and tell people, “Oh, yeah, I'm an interface. I've had experiences since I was a child. That's why I'm here.”

And I, actually, at the time, I really didn't know that was the situation. I just knew for some odd reason I got selected on it, and I was involved with it.

But the one guy says, “You know, we can't go ahead and treat injuries to the different entities that we come up on. We have to know specifically what type of first aid procedures, until the medical team gets here.”

And there was a medical team. I think they called it a triage team. And the triage team, they had to come in. They had doctors, but they had the experts that knew how to deal with them on a much higher level. But in the interim, we had to be able to render first aid.

So this person went ahead and showed me. I mean, I'm going to be talking kind of crazy here, I'm sure, but some of the things . . .

Okay. For example, for a Band-Aid, some of our entities you couldn't use a Band-Aid. The simple little thing of putting a Band-Aid on what might be like a cut, that could kill them.

You actually used something that looked like plaster of Paris to put on there. And, you know, you had a medical kit solely for extraterrestrial.

If you looked in there and that book was absent, you'd just think, “Who put this crazy stuff together?”

But you had certain types of compounds that was made, just from specific dirt. That's the best way I

can put it. Yet, this was first aid for them.

Iodine, for example, we could go ahead and put iodine on things that we have. That can kill some of them.

The book, or catalog, that I saw of the different 57 species was broken down by sections. And it would go ahead, it would have a picture of the entity. It would have certain statistics of the entity, and it would give a brief bio of the entity.

Then it would go ahead and list various types of possible injuries that could occur and the first aid for that.

Now, you know, I got to go over it maybe about four times. A lot of people think I was given the book; I took it home and I read it and I kept going. No, no, no, it didn't work that way.

Some are so human looking that it would be very difficult for you to tell them any difference from us. They might not catch a punchline of a joke. They're very – how can I put – very serious.

So, you know, levity, they may not be able to take in right off the bat. It's a learned process for them. They'd have to learn.

You're in a dark room, and you have, say, a red sheet of paper. You can't tell it's red. They pick it up and touch it, and they say, "Oh, it's red."

You can't see your hand in front of your face, but yet, they can go ahead and they can distinguish colors that way.

You have some that are, once again, humanoid, and you have to be very careful because when you come up on that, you very quickly think that they're human.

But their pupils [Stone means 'irises'], like we have blue, green, and all that good stuff, brown. Their pupils are black. Therefore, they will go ahead and they will use contact lenses to cover that up.

But if they forget those contact lenses, a person seeing them will be shocked because the eyes will look, you know . . . nowadays they're just going to say, "Oh, those are contact lenses." And I don't know how many kids I saw show up having contact lenses that looked like cat eyes. And, you know, the whole situation is that's what they would say today.

But back in the day, there were no contact lenses. And back in the day, they'd wear dark glasses.

So when you see a picture and it's dark, there's no need for dark, dark sunglasses, you might ask yourself, "Is that person really from this planet or is he hiding something?"

I would say the freakiest was, and I'm going out on a limb here, because I hate doing this, because, "Oh, no, that's already been talked about", is what you would call . . . I don't know, having a grasshopper-like face. And a lot of people call them the "praying mantises".

But I didn't have any – how can I put this? I did not have any real problem with them, you know?

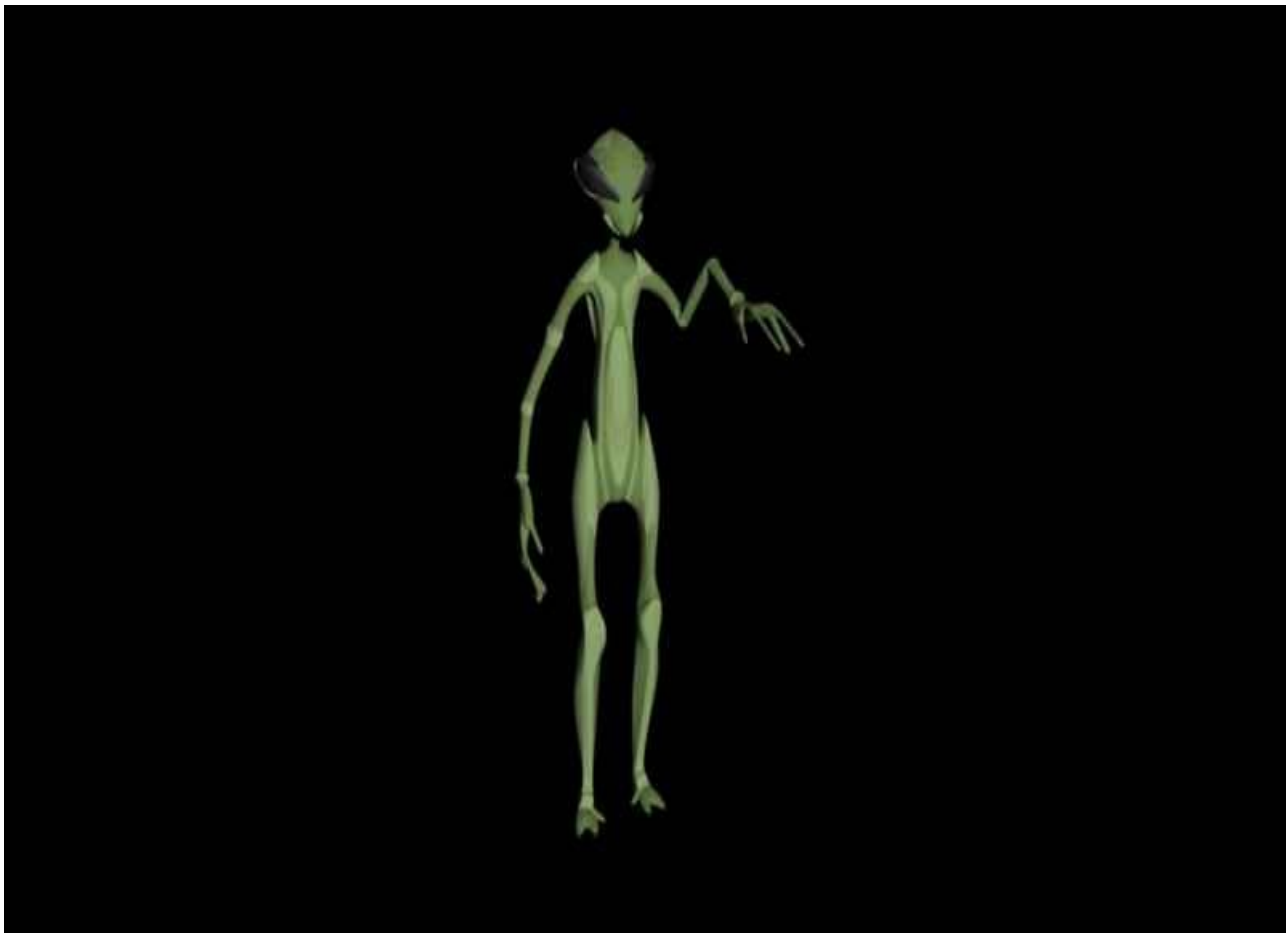

I got along good with them, but the one problem I did have – remember, I said they had the face about like a grasshopper. They ate like a grasshopper too.



And I think because when I was a child, we tried to help animals and grasshoppers, and I liked grasshoppers when I was a kid. Not to eat, but I just found them fascinating, you know? And I'd watch them eat, and I think that prepared me, actually, for when I saw these creatures and the way they ate. Because I had many people - “That's disgusting!”

And I just went ahead and said, “You know what? That's natural for them. The way we eat may be disgusting to them.”

And one of them actually made a joke about it – one of the insectoids that looks like the . . . - actually made the joke by saying, “Well, you got it right. We think that it's disgusting the way you guys eat. It's not normal.”

What's normal about anything here?

* * * * *

David Wilcock: All right, so that's some pretty heady stuff there. When we get into these kind of specific details, to me, that's where you start to feel the truth coming through. Somebody making up a story is not going to have this much level of specific detail, wouldn't you agree?

Corey Goode: Yeah, the fine details are where people get caught up, and also, remembering those fine details.

David: Right. If you're working in counterintelligence, would it be normal to try to get people to give fine details so that they could get caught up in them and make mistakes if you're trying to catch a liar?

Corey: Oh, yeah. Definitely. You're going to ask a person the same questions, pose it differently each time and work your way back to the details that they had given prior to see if anything's changed or to see if they can keep up with their lies.

David: Yeah, and Stone has been out there for 20 years, and his stories have always stayed the same, regardless of the fact that he's not ever been able to capitalize on this. He lost one of his sons.

It's actually a very sad story because part of his toll of being a whistleblower was losing one of his kids, apparently.

Corey: Right. Yeah. Consistency is very important.

David: So here he is describing this experience of being an intuitive interface for these ETs on these retrieval teams, but that the other guys on the team did not necessarily know that that's what he was there for.

Would it be common for members of a team to not actually know exactly what every member of the team is doing?

Corey: It depends on the situation. There are times when the team has to know all about their teammates. You also have compartmentalization in there as well. Even in small teams there is compartmentalization.

David: Right.

Corey: And it sounded like they had a pretty good idea he was there to do more than be the NBC [nuclear, biological and chemical] guy on the team.

David: So he's describing 57 different varieties of extraterrestrial, and that has been something that has jumped out at me over many years. You were told to read The Law of One material.

And in The Law of One material, it's explained that there are 53 civilizations in the so-called "Good Guy Confederation". And then they also say that George Hunt **Williamson** was correct in a lot of his material and he identified six negative groups.

53 plus six brings us up to 59, which is only two away from 57. So how does the number '57' - I just explained The Law of One side of things – how does that number maybe permeate into some of the things that you might have also heard?

Corey: Now, if these crash retrieval teams . . . they're going to be given a list and information on non-terrestrials that are interacting with us the most, that they're most likely to run across in a crash situation.

David: Right.

Corey: Right.

David: Well, you've mentioned before the Super Federation. And what is the Super Federation doing here? Would they be working with us closely enough that they'd be in our airspace?

Corey: Many of them in the Super Federation are . . . they're what they call the 'genetic farmers' – a lot of them. There's a huge experiment going on, a big genetic experiment going on, and they're taking part in it.

They don't always come down to the surface, but, you know, they're going to have to come down to the surface to pick up subjects to test and to try to put new genome into.

David: So they could be some of the groups that are crashing because they're actually operating in our airspace.

Corey: They are, yeah.

The crashes are occurring from the Super Federation group. There are also non-terrestrials that come into our solar system. As they're traveling around to other solar systems, they'll stop in to get supplies or do some trading real quick before they leave. So there's a larger number than that that are actually coming in.

We developed the ability to monitor our own skies and police our own skies that dropped quite a bit the number of non-terrestrials that were coming into our atmosphere, doing what they wanted to do, and then heading out.

But there's a lot more than 57 or 59 that are occasionally coming in and out of our solar system and interacting with us.

David: So it's possible that these crash retrieval teams could come across something that they did not have in the flipbook and would therefore, would be unfamiliar to them.

Corey: Absolutely, yes. And that's what happened along . . . That's how they built up to 57.

David: I see.

Corey: A lot of times, in one of these crashes could be a non-terrestrial that they've only seen once or twice. And others could be non-terrestrials that they've run across quite a bit.

David: So what kind of protocol would they have if it was something that they hadn't seen in the book? What would be done at that point?

Corey: Well, most likely, they're not going to try to do any type of medical care on them. And usually they don't know what type of pathogens they're carrying or what pathogens of ours that they're susceptible to.

So they're going to cordon it off until they have medical scientist professionals come in.

David: So there are different protocols in place if they don't know the medical procedures that would be safe, where they might be a lot more hands-off at first?

Corey: Right. If they're coming up on a completely unknown crash, there are a lot of things to take into consideration from the craft. What is it carrying? What type of chemicals or biologicals are emanating from it that can make them sick? You know, there's a lot to consider.

So they usually cordon it off and then send in some specialists to take readings. And if there was a being that was injured, they would probably succumb to their injuries by the time they got medical attention to them.

David: Are there problems with radiation and radioactivity in some of these crashes?

Corey: Yes. Yes. That's why they have NBC units traveling along with them – nuclear, biological, chemical.

David: Have there ever been cases of crashes where little nanites come out that could kind of crawl along the ground and then attack people or something like that?

Corey: Ah, I haven't heard anything like that. I have heard of people becoming ill and then dying from walking into crashed craft.

David: Hm. Just being exposed to it for a short time is enough?

Corey: Being exposed to it . . . Yeah, different radiations, the biologicals, pathogens from the non-terrestrials . . . There's a number of things.

David: Now, Stone is describing the idea that certain extraterrestrial physiology, that they could die from just the adhesive, or whatever it is . . . I guess it's the adhesive on a Band-Aid.

Corey: Or it could be the chemicals in the adhesive. Yeah, there . . . And I remember reading, because some of the “intercept and interrogation” subjects that we had had, obviously, had medical treatment sometimes.

They have to know how to triage and stabilize these beings so that they can get more information from them.

David: Well, he said that there was a certain type of wound-healing that might involve plaster of Paris.

Corey: Yeah, well, what I've read was that some of these beings were having kind of like anaphylactic shock to chemicals that were being administered to them that would be fine for humans and animals, that these beings were showing, basically, signs of an anaphylactic shock and dying.

David: Well, I've had other insiders tell me that ETs are shocked by our planet, in general, because of the number of chemicals that we use and that it's way more than they would use in their own worlds. Have you ever heard anything like that?

Corey: Right. They're so advanced that they don't need all these different chemical compounds.

David: And maybe because they're not exposed to them, they become a lot more sensitive to them.

Corey: Right – as well as pathogens. They don't have a way to fight them off.

David: Something like iodine, though, when he mentioned that, it seems like that's a pretty normal substance in the periodic table that helps biological life.

Corey: Well, there are a lot of human beings that are allergic to iodine, that can't have iodine in their system at all or on their skin. So it's completely plausible that something like iodine would cause some sort of allergic reaction in a non-terrestrial.

David: Now, why do you think that a certain type of dirt or mud would actually function as a Band-Aid for certain extraterrestrials? Is it the minerals in the dirt, or . . .?

Corey: Well, the minerals, and, also, the caking of the mud or dirt is also going to allow their blood to coagulate.

David: Do some of these ETs heal a lot faster than we do?

Corey: Yes. Some of them that I witnessed that had been treated were already looking very healthy after they had had very bad injuries. And that could be some of the technology we used on them, but usually, after they were stabilized, they were put in a cell and kind of left alone. So they were healing on their own.

David: And since we're talking about all this, I'm curious about what do you end up feeding extraterrestrials that are in captivity? Can we feed them our normal food . . .

Corey: No.

David: . . . or do they sometimes require very unusual things?

Corey: Yeah, usually it's some sort of compound that's mixed together that has . . . It's kind of like a meal supplement that you would take instead of eating. It has all the minerals that they need - vitamins, everything – protein – everything that they need.

And different non-terrestrials have completely different systems. Some of them don't really appear to have an operating system in their body for digesting food.

So, yeah, they would have to communicate through an intuitive empath with these beings. You know, “How can I help you? What can I do?”

These beings will reach out to intuitive empaths and say, “I need nourishment. This is how you prepare it.”

David: Is drinking water going to be a fairly common thing throughout most being's biological life?

Corey: Well, interestingly enough, I remember seeing that in some of the beings they could only use distilled water for hydrating them or treating wounds.

David: Hm. Wow!

Corey: So I imagine that water can absorb minerals and all kinds of stuff. So it would have to be a purified water source.

David: So even though water is healthy for us, it's also got this blend of all the minerals that are unique to our planet, and maybe other planets might have a very different type of mineral blend that that water would have in it.

Corey: Right, right. And, you know, distilled water has been stripped of all that.

David: Right. Now, he also mentioned . . . He said “pupils”, but then he talks about people's pupils being different colors, so he obviously means “irises”. And he said that some ETs have black irises and it would be quite striking for us to see that if they didn't wear these contact lenses. What was your reaction to that part?

Corey: Well, I had actually seen beings that their eyes were . . . all you could see were the whites or pink. On each side of the eye it was black. And that's in more than one species.

And he mentioned that this was a species that was very human looking, that you would walk up upon and you would think you're walking up to people. And then you get right up to them and then you would notice something was different or not right.

David: Well, let's just clarify this because there might be some confusion in the audience. He's not saying that the entire eye, including the whites of the eye is all black like you see in a lot of these TV shows and horror movies.

Corey: No. The iris.

David: Just the iris. Right.

Corey: Right.

David: Those types are going to usually wear contact lenses before they would appear to us?

Corey: I hadn't heard of them wearing contact lenses, but I had heard that they will wear sunglasses. Or depending on the group, if their eyes are different, maybe put on some sunglasses. If their ears are different, just like off "Star Trek", you know, put on a hat, cover up the pointy ears.

David: Right.

Corey: You know, that's if they're anticipating running into the indigenous people.

David: And he also mentions running into some kind of insectoid life – people with a head like a grasshopper. Where do you think he might have encountered beings like that? What might have happened, because he didn't really get into where he saw that?

Corey: It didn't sound like it was a crash retrieval situation. It sounded like he was at some sort of facility that was an inter-species sort of base, because he was interacting with them.

David: Right.

Corey: He told the story about one of the people said the way they eat is disgusting, and he made a remark that, “Well, they probably think the way we eat is disgusting.” And one of the insectoids chimed in and agreed with him . . .

David: Yeah.

Corey: . . . which is another thing that has come up that we've heard in UFOlogy, and which I experienced personally. A lot of these non-terrestrials cannot stand the smell of us, the sight of us. We're just . . . We're very unattractive to them and we stink.

David: I also remember **Pete** Peterson telling me, and I've said this many times, when he met with a grasshopper-type being that it would put its head down when it laughed because it had these mandibles on its mouth that would open up.

Corey: Yeah. The one that I saw that sticks out the most was not exactly in a laughing mood.

David: Yeah.

Corey: It had been captured and it was being interrogated, but it had the mandible things that come out like this [**Corey** spreads his hands open and closed on both sides of his mouth]. It had a head that looked kind of like an ant or a grasshopper. From the front it was like this [**Corey** uses both index fingers to point outward from the sides of his forehead]. If it turned sideways, it stuck out a little bit further.

But a lot of times, people will call those Mantises, but there are several different types of insectoids.

David: And do you think that with Stone being the guy who first put out “57 different varieties” and that most of them are human or hominid in nature, could you just clarify for us, again, if that is consistent with your observations? Is there some sort of human setting or human-like setting that life, when it's intelligent, seems to take?

Corey: I've heard that there are different configurations of beings out there, but for the most part they are humanoid – you know, two arms, two legs, a head, fingers, toes of some sort.

David: What are some of the different configurations?

Corey: I've heard of configurations of . . . I think we've heard of like crystalline type beings or beings that were energetic kind of blobs, but not exactly flesh and blood as we would know it. (23:00)

David: Right. Okay. Another thing that Stone mentioned was this bizarre sensory capability that some of these beings have, where they could touch a piece of paper in the dark, complete dark, and know that it was a red color.

That seems pretty outrageous. Some people might try to laugh at him or discredit him just from that one statement. What are your thoughts on that?

Corey: Well, some of these beings see through a different spectrum than we do. Their eyes absorb light from a wider spectrum.

David: Hm.

Corey: So the visible light that we use to see, if you turn that off, there's still a little piece on this side and that side of that spectrum that they can see. And there's also the fact that, I've heard, that a lot of the mind control that is being used on humanity has suppressed a lot of our senses, that we would be capable of things similar to that if we were not being manipulated.

David: All right. So we are finished with this episode now. Sergeant **Clifford** Stone has given us some really really great material. He is a brave American hero.

You have to understand how difficult it is for people to come forward and share this material with us.

When people want to laugh at this guy on the Internet, they don't realize, necessarily, that he has suffered poverty. He lost one of his children, and he has nothing to gain and everything to lose by coming forward.

So we applaud him as an American hero, bringing forward this information to help us all move into the Full Disclosure that we are hoping to get out of all of this.

So now, we're going to close out the episode with some of **Clifford** Stone's final thoughts for us after sharing all this very deeply personal and emotional information.

I'm **David Wilcock** here with **Corey Goode**. This is "[Cosmic Disclosure](#)", and we're going to close out with a few thoughts from Sergeant **Clifford** Stone. Thank you for watching.

* * * * *

A MESSAGE TO HUMANITY

Sgt. **Clifford** Stone: Now, the whole situation is there's that contact that's going on and there is interaction, but what we don't understand, we fear.

And when it comes to abductions, we don't understand. We fear. And I've always said, "I have never been abducted," at least, I don't believe I have.

But now, with me saying that, let me tell you that I remember at a very young age seeing the stars where they cannot be observed anywhere on the planet of the Earth like I saw them on several occasions.

The one thing that I'd want everyone to understand and take away from this interview, if nothing else, I'd want them to go ahead and remember, one, let no one live in your mind rent-free. Two, search out and seek the truth.

Then, three, go ahead and demand answers on those things that are still left in question as a result of the exposure of those things being exposed by the truth.

The problem is, right now, too many people let people live in their mind rent-free, and that is something that you just cannot do.

You have people out there with their own personal agendas, and they're telling you that the Moon is green cheese, and everyone wants to believe that.

The whole situation is, if you go ahead and research the facts and you come out with understanding that the Moon is very complex, and there's a lot of mysteries. And we want those mysteries answered.

When it comes to UFOs, it's a self-keeping secret. Everybody knows UFOs, per se, as UFO reports,

exist. They are seen on a daily basis.

A government saying, "We're not going to investigate no more," does not make them go away.

There are people who have their psychic insulted on a daily basis by events of high strangeness that takes place, and no one wants to provide answers for that.

In short, we need those answers.

I know, for a fact, that eventually an event is going to occur, by design or by happenstance, that is going to be so profound there is not going to be NO way to cover it up.

And not just the people here in the United States, but the world, are going to know, once and for all, we're not alone in the universe. But what we need to do is have people psychologically ready to accept that.

And I'll tell you right now, people say, "Oh, well, it's going to hurt religion." No, it's not. "It's going to hurt this. It's going to hurt that." No, it's not.

You want me to tell you who it's going to hurt? The scientific community of the world, because the scientific community of the world right now is so self-centered within itself. They can say, "We can accept extraterrestrial beings being out there."

But can they really? Because the whole situation is they are locked within their own paradigm, where they know of exotic propulsion systems that someday we will acquire. And we will visit, not just the planets in our solar system here, but planets in other solar systems that are light years away.

And we're working on that technology right now. It's not a secret that we're working on it. It's just people don't know.

And these are the facts. These are the truths that people need to seek out.

And when they do that, they will realize that we are seeing UFOs in our skies, intelligent vehicles that

are coming here from someplace else under intelligent control, by entities not of this world – maybe not even of our dimension.

But they have to realize that tomorrow we'll acquire that technology.

Day after tomorrow, we're going to become someone else's UFOs.

Bottom line: it's going to happen.

What's very key to all of this is that each and every person keep an open mind. And I hate to put it this way, there's a lot of things that have went on that for reasons I can't get into have to remain between me and God. That's the best way I can put it.

A lot of times I don't feel comfortable about talking. You relive it in your mind. It don't go away.

You see it in living color and there were those times I was one voice saying, “This is an intelligent living creature.” And some people would say, “No, no. This right here is a creature. It's a new form of life. It's a new animal.”

And dare I say this, at times I felt that the intelligence of these creatures, I felt that when we go ahead and put them on a lower pedestal than us, then the situation is we are not recognizing the fact of their intellectual capabilities – what we have to learn from them. But for selfish motives, we degraded them far below even that of what the human species would be.

Yet, because of their intellect, they are on a much higher pedestal than the human species is, and because of their spirituality.

And, you know, I know a lot of people was not as vocal as I was, but shared the same concerns that I was airing.

And one thing I want to see . . . I really want to see whether people believe in UFOs are here, whether we have extraterrestrials here or not. I want to see some type of recognition that in the event of that day occurring and we have intelligent beings coming here to this planet, then there are certain rights, certain

civil liberty rights, recognized under law.

So no government, no military entity, for selfish motivation, can go ahead and treat them like test animals. And to be sure, lab animals have more rights than our visitors and are protected much more than our visitors.

Because as long as you go ahead and say they do not exist, no laws are going to be enacted.

So I'm not asking people to believe that they're here right now. I know they're here right now, but I'm asking to consider that eventually it's going to happen. But when it does, we need to have those laws in place.

And on a closing point, I'd like to add is that we have nothing to fear. We only have fear itself to fear.

If we open our minds and hearts, we have everything to gain. We have much to learn and it will be a brighter future if we can learn, as our visitors have learned, to coexist peaceably.

And also, have our visitors here, as one person put it, we should be willing to learn if they are willing to teach us. We should be willing to teach if there are things that they would like to learn from us.

So it's a trade-off, but the whole situation is we have much, much to gain just by keeping an open mind and seeking understanding and seeking out the truth.

Cosmic Disclosure: Founders of Solar Warden with William Tompkins

Season 6, Episode 8

David Wilcock: All right. Welcome back to "Cosmic Disclosure". I'm your host, **David Wilcock**. We're here with **Corey Goode**.

And in this episode, we have deeper insights into the Secret Space Program, with the astonishing disclosures of **William Tompkins**, our 94-year-old aerospace engineer who is clearly one of the

founding fathers of the very Solar Warden program which he named – that same code name – that **Corey** later worked in.

In this first interview that we're going to show you, **Tompkins** gets into detail about one of the craft designs that he was working on for the Navy. Let's take a look.

* * * * *

NAVAL GALACTIC BATTLE GROUP

William Tompkins: So we talked before about the different types. And this is a two-kilometer long spacecraft carrier, and it's streamlined to a degree.

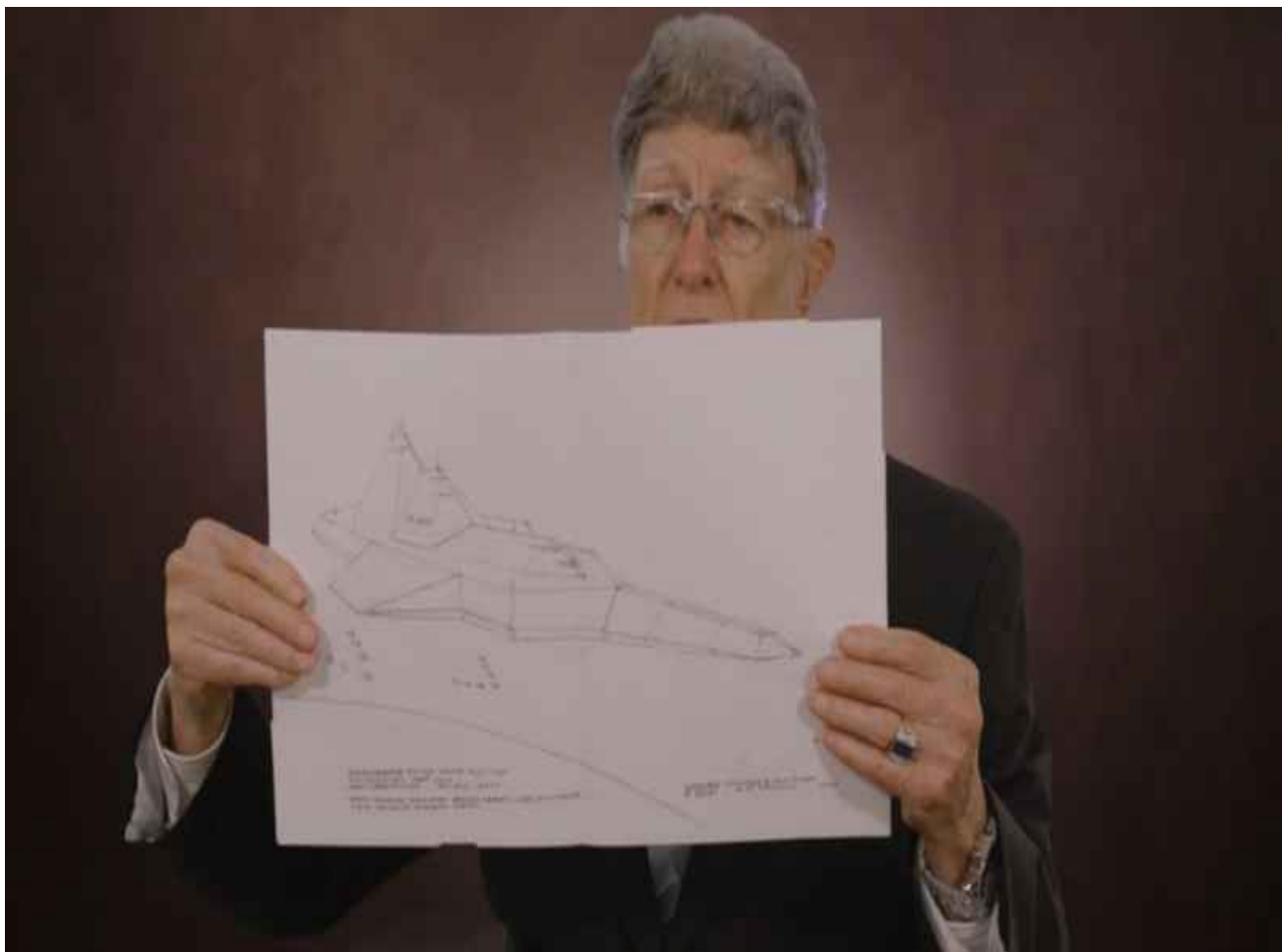

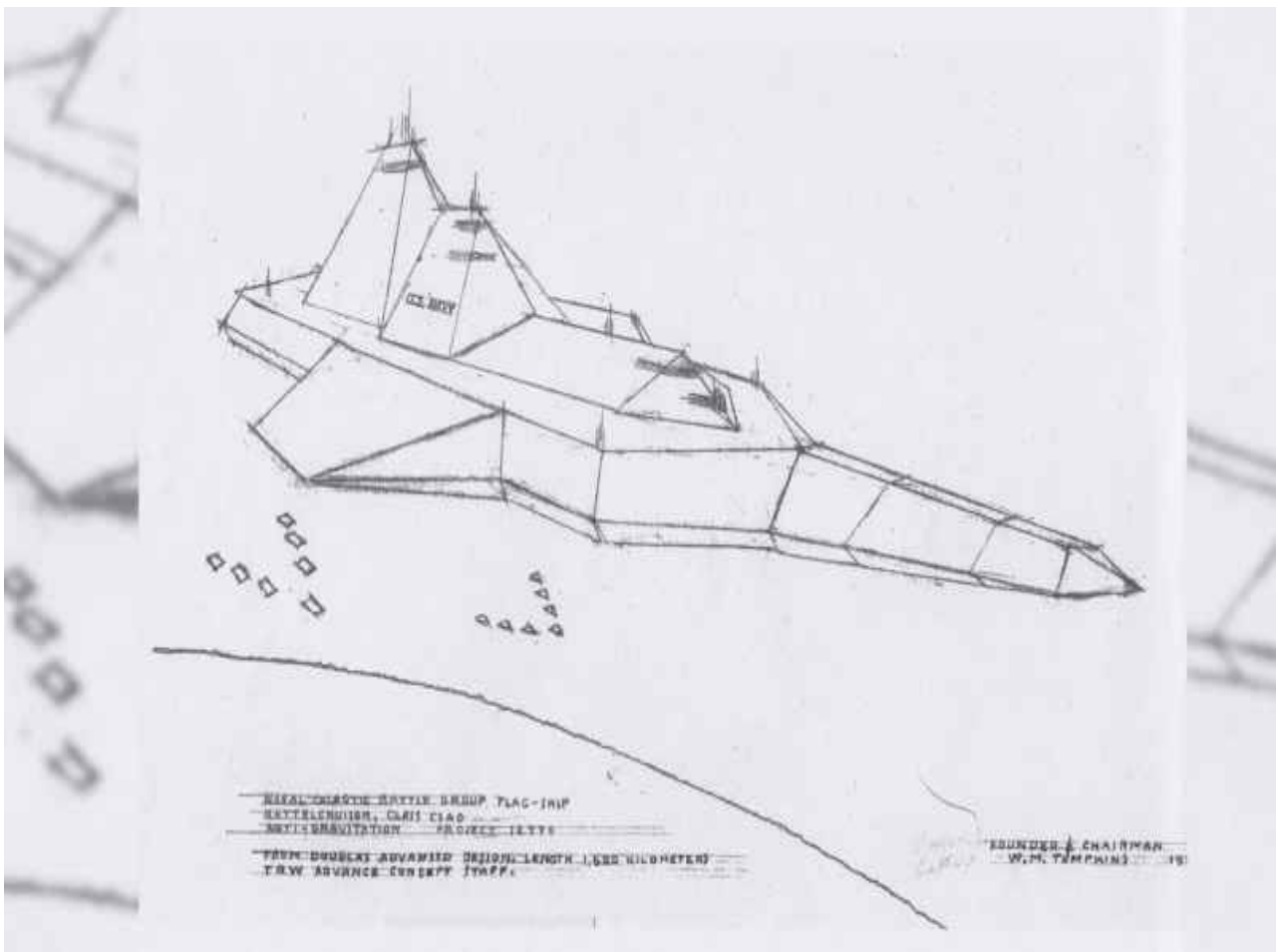

And so in one of the big design review meetings, one of the managers said, “Wait a minute, Bill, it's a vacuum out there. You don't have to make it pointed. You don't have to have atmosphere to go working through.”

And so I said, “Well, that's true, but the electromagnetic protection system, which we still are not sure how we're going to word, may or may not be capable of handling all of the different types of vehicles or weapons that could be . . . being used on us. And also, under certain conditions, we actually can get into the planet's atmosphere and operate. So anyway, we got around that one.

Now, if you can picture here this area down in here [Bill points to the bottom, center of the craft] . . . I'm going to switch these, and you're going to see the lower part of the hull.

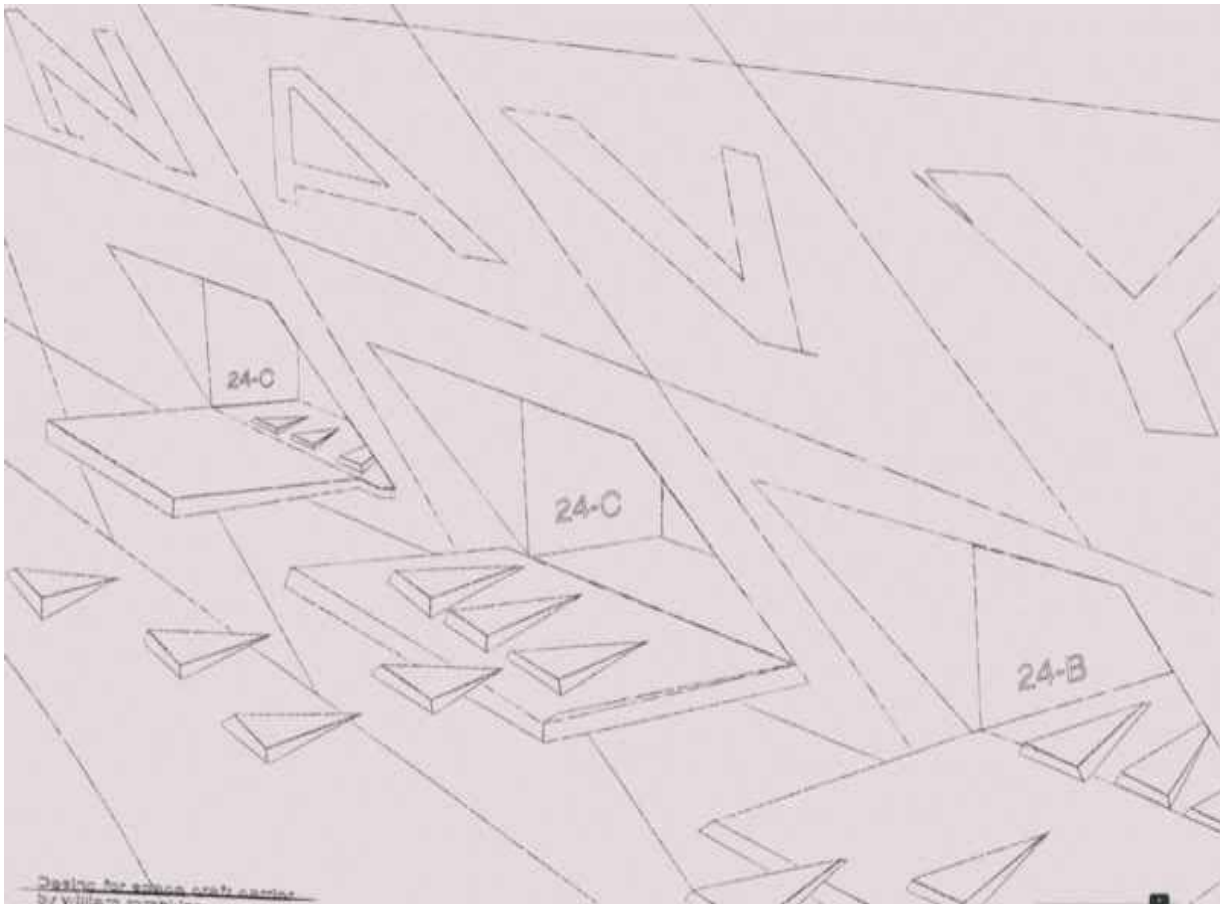
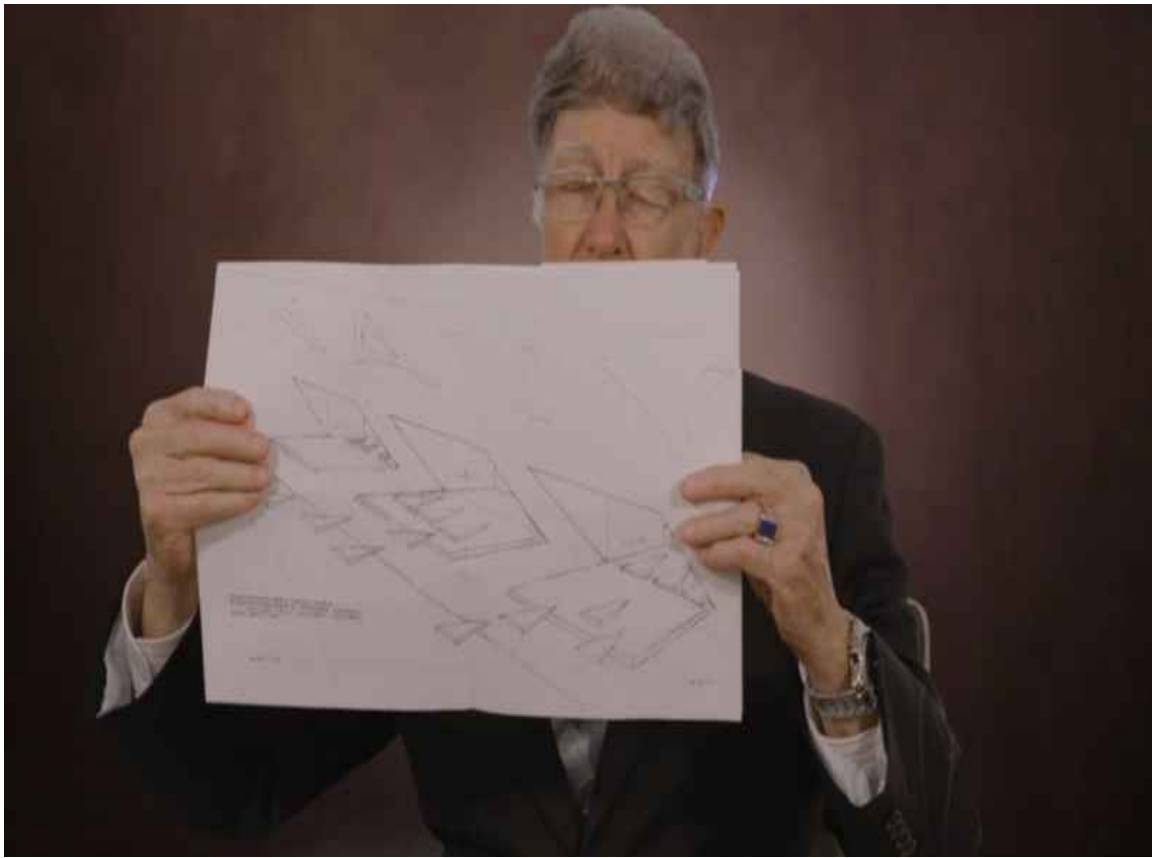

And what you see there is the different classes of attack and fighter aircraft returning to the mothership, or the spacecraft carrier, and with a vacuum-controlled entry sections . . . Actually, they would design to fold down so that you're already in support of making inside landing.

Nobody actually flies in these squadrons controlling any of the vehicles. It's all automatic, so you're not going to be hitting the walls or any of this kind of thing.

But very quickly, you can open these hatches on the side. The hatch then becomes sort of a platform to possibly land on if you're too low. And this answers the question of how do we handle the large spaces aboard the ships that are going to be operating on the missions.

So what we had done then was, using the same type of design concepts, we looked at the Marines' missions. We looked at the communication missions. We actually came up with virtually hundreds, then, of missions and sub-missions that we then in the tank [think tank] made recommendations back to the Navy themselves.

And one admiral, when he saw that first illustration, he made the statement that just the shape of that's going to scare them away. They'll turn around and go back, because it is a pretty hot configuration.

Some of the others are not as good and actually some of them are rectangular, depending on what the mission is required to accomplish.

* * * * *

David: So that's a pretty technically detailed diagram. And it's just one of a variety of things that come from this guy who has no financial interest in this. His book didn't sell very much. He's just living on a fixed income. And yet, that degree of precision in the art doesn't seem like it would be coming from somebody who's trying to make something up.

So I'm curious about how similar that looks to anything that you saw?

Corey Goode: That was most likely one of the concept designs that probably got fine-tuned. But there could be a craft that looks like that out there that I hadn't seen. I didn't see all of our vessels out there.

Now, that looked very similar to longer, wedge-shaped vessels that I saw that had areas coming up off the top almost like you see on a Navy vessel on the ocean.



And also, it had stealth edges. The corners were very much like the stealth ships that you see – how they curve.

David: Well, and something kind of caught my eye, which is that in his discussions with his superiors on the design, they said, “Oh, you don't need to worry about aerodynamics. It's not going through an atmosphere.”

But what I'm thinking of is, “Wait a minute. There's all this charge that you've got to move through even in space. There's inertia and there's electromagnetic fields.

So do you think that part of the reason why everything has an aerodynamic shape is that the basic

vacuum energy of space itself has some sort of resistance that you have to cut through when you go through it?

Corey: They don't all have the aerodynamic shape.

David: Oh, okay.

Corey: And as far as moving through charged particles and all this stuff in space, that's what the material on the outside of the craft and the electromagnetic shielding is for.

David: But in a case like this, for that particular mission, if it's also going to go through a planet's atmosphere, it would be good to have some aerodynamic qualities.

Corey: Right. The vessels that travel inside our atmosphere and out are usually going to be somewhat aerodynamic, even though with the propulsion systems they have they are not traveling through the atmosphere per se. They are in a bubble. And inside that bubble, the bubble is traveling.

David: Is there a reason for why stealth technology seems to involve these different flat panels that are kind of arranged at different angles? What's going on there?

Corey: It deflects radar, lidar, different waves, away from the receiver of the radar or lidar. So how it works is if you send it out and it hits a flat surface that is angled right, it's going to come back and you're going to get a report from that wave bouncing back.

If you have sharp angles, then very little of that wave is going to bounce back. The rest of it's going to be dispersed, and the waves will bounce off, but they're not going to hit the detector.

David: Well, I know that my insider **Pete** Peterson described that when the stealth was rolled out for Gulf War I, that it had in fact been mothballed for 20 years and was a very archaic and almost useless piece of technology by that time. Here he's [**Tompkins**] doing something in the 1950s that looks like stealth.

Corey: Yeah.

David: So that's pretty darn interesting.

Corey: Stealth goes way back.

David: Really?

Corey: Right. Stealth was being developed soon after the discovery and invention of the radar.

David: Wow! So I noticed in the second image that he showed that you have these very, very large doors, or hatches, as he was calling them, that open up on the side of the craft, and then a lot of little triangular wedges going in.

So what was your feeling when you saw that part of the illustration?

Corey: Well, as far as the doors opening, I had seen elevators that lift aircraft, move aircraft around. But if you have a door opening out, that can cause a lot of logistical problems if you're in battle or if you are traveling at a high rate of speed.

So usually, they have the doors open like this [side to side], up and down, and not protrude out.

David: Right.

Corey: But if there was another purpose and a need for it, I could see why they would develop it.

David: What about the actual shape of all those craft that were going into the larger craft?

Corey: Yes, that was very familiar. And the fact that he mentioned in these newer vessels or carriers, they do fly drones. They have people all inside [buildings or large craft] sitting in long rows flying drones, and they control a number of drones apiece.

David: Really.

Corey: Yeah. Little constellations of drones.

David: So what would this type of craft that he was designing be used for? Is it an attack craft? Is this a support craft?

Corey: It can be offensive and defensive, but usually these craft are designed to be offensive for attacking an enemy.

David: Does the Space Program have any proclivity towards doing an offensive attack on a civilization that they think they could conquer and overwhelm? Or is there also . . . is it mostly going to be defensive when they're out there trying to see what's around and getting attacked?

Corey: Well, it depends on who is in charge of, I guess, the Navy assets at the time. These people follow orders. So if they have a problem with attacking another species, they have to follow orders.

David: Well, in the case of a movie like “Avatar”, we have a clear example of our own government/military-industrial complex, in what would appear to be the future, having developed a space program, going to another planet with people who are tall and have blue skin, but there was something there that they really wanted, which was this unobtainium.

Do you think “Avatar” is describing something that is actually happening? Are there certain cases where planets are invaded for their materials?

Corey: Well, I do know that certain aspects of the ICC, but especially Dark Fleet, are going out on offensive conquering missions. And they're doing this alongside the Reptilians.

David: Well, and I do also remember **Pete** Peterson telling me that many of the craft that you see in “Avatar” are exactly identical to stuff that he had actually seen or worked on. I'm wondering if any of them look familiar to you when you saw the movie?

Corey: I didn't witness a whole lot of craft that flew inside of an atmosphere.

David: Ah.

Corey: So all of those craft were clearly designed to fly inside of some sort of a dense atmosphere. The craft that I saw were not built to operate in atmosphere.

David: All right. Well, speaking of James Cameron, not only do we have “Avatar”, he also had that movie “The Abyss”, where he describes extraterrestrials underneath the surface of the ocean.

And here we have **William Tompkins** in a very interesting discussion about undersea bases. Let's take a look.

UNDER SEA BASES

Tompkins: I did get hired by General Dynamics for a Navy program. And this program was to locate German submarines – anti-submarine warfare program.

And what's interesting about this is that the Navy selected the Lockheed P-3 patrol bombers to be the air vehicles to locate German ships and submarines.



Lockheed P-3 patrol bomber

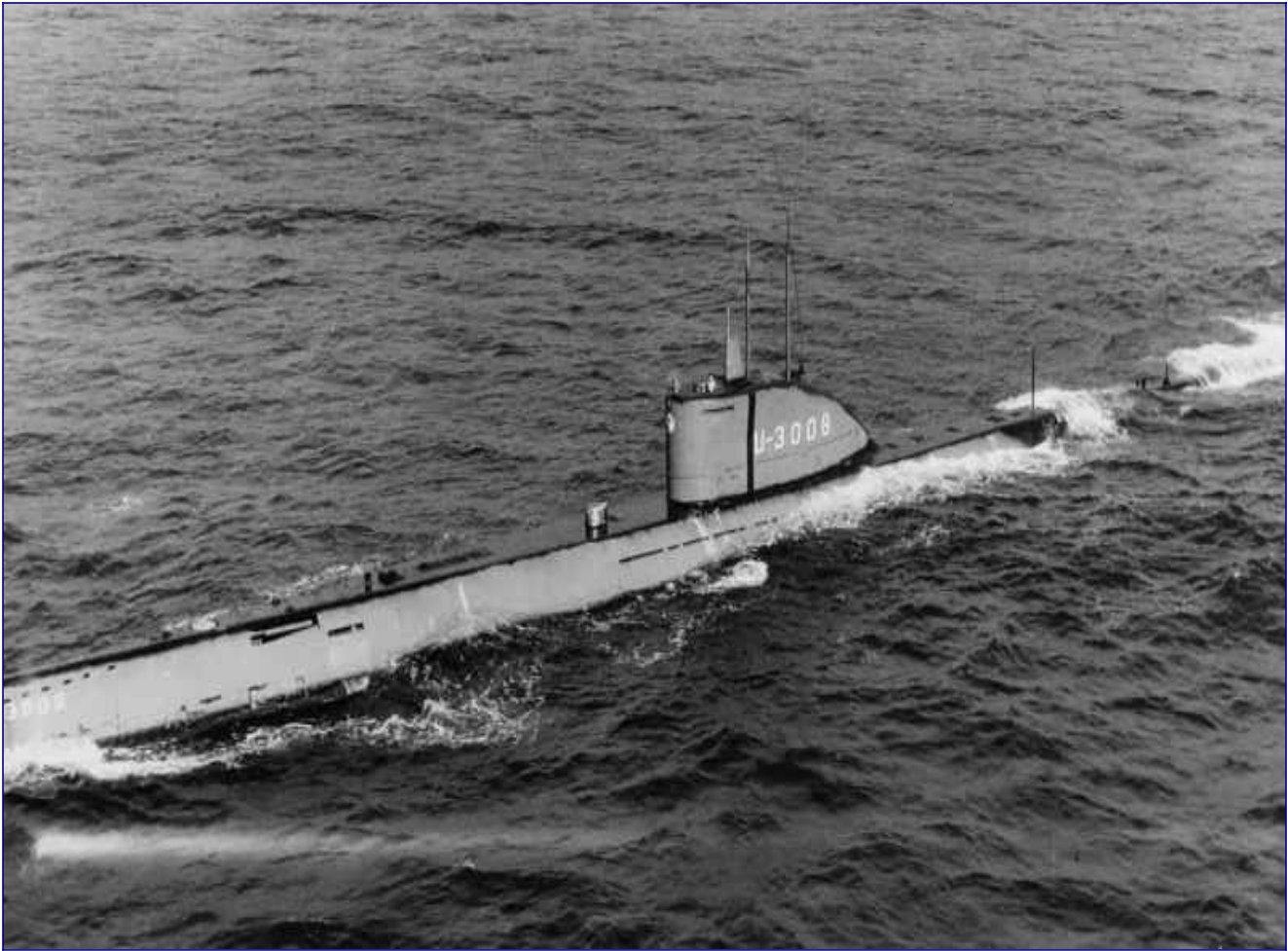

German submarine

This is the Cold War now, and so there was roughly 15 other NATO countries who were using the same aircraft, the same electronics, the same sensing systems and the communication system – all of it engineered and designed in US.

And so the United States had 120 of these, and the NATO countries had like another 60 of them, all out looking for German [and/or Russian] submarines.

But that's not quite the numbers. It's more like we had 2,000 of these and NATO had another 1,000 of these – not quite that high. And remember, there were only 11 Soviet submarines operating at that time. There were many of them that were in training operations, but they weren't tactical.

And so here we've got 2,800 P-3 aircraft flying all around the planet 24 hours a day looking for submarines.

Well, gee whiz, that's not exactly what we were doing either. And there's a title to the program, which is the mission ASW – anti-submarine warfare. But there's also one which is ASUW. And so the “U” is for 'unidentified extraterrestrials'.

And so this was the second-largest amount of military money allocated for a program on the planet. It's peacetime, but it's sort of a war condition. And we have all of these airplanes out, and it became necessary for a group, which I then was manager of, working for Data Graphics, which is a subsidiary of General Dynamics. And later on, I worked for the corporate office on the red team at the corporate level.

And when we look at the size of this program, the number of personnel that have to be trained to fly these aircraft, the upgrading continually of the sensing systems, the underwater systems of the satellite system programs that were required to be on board these aircraft, it's absolutely unreal.

What we were really doing was looking for extraterrestrial vehicles in the ocean and in the large lakes and their bases on the bottom of the ocean.

People don't realize how much money, how much time, and how many people have to be involved in these programs.

And what are you doing? You're looking for extraterrestrials. Do you realize what we're saying? I mean, you're looking for extraterrestrial vehicles and bases. Your Navy is.

* * * * *

David: Well, the first thing that strikes me about the interview footage that we just saw here is the scope of this classified military operation to try to actually identify who is on our planet, where are they, what is their infrastructure, what is their agenda?

It would have to involve a massive amount of effort. So what were your thoughts on that?

Corey: I have heard of operations similar to what he was talking about, of fleets that were combing the ocean looking for submerged bases, and also USOs – unidentified submersible objects, I believe.

Now, from what I understood, very few people in that fleet would know what they were actually looking for. Everyone would go about doing their normal jobs. It'd just be a normal mission or a training mission, they'd be told. But very few intelligence people in that fleet would know exactly what was going on.

David: Well, to have 2,800 P-3 aircraft airborne at all times – this is obviously before the era of accurate geostationary satellites.

Corey: Right.

David: We're talking about a massive, massive operation here. How long do you think this had to have been done for?

Corey: Until they had strong enough sonar that would penetrate to the deepest parts of the ocean, and until we had the satellite coverage we needed. They had some sort of groups of aircraft or Navy vessels that were combing the ocean looking for non-terrestrials.

David: Do you think that there might have been a temptation at some point to tell the public, “Hey, we're aware of this extraterrestrial presence. We're doing the best we can. We're cataloging it now.”

Or was it just really important the whole thing be secret to avoid a panic of some kind?

Corey: Well, just in general, the Navy . . . I mean, you hear “loose lips sink ships”. Information is very compartmentalized to begin with, but this is not long after World War II, so everybody still had a different mindset than we do today.

If the government told you to stick a lit cigar in your ear, you'd say, “Yes, sir. Give me another.” That's just the way people were programmed.

David: So **Tompkins** is also discussing another point of corroboration with some things that you've said, which is that there were, in fact, underwater bases to be seen.

So could you review for us what your knowledge is about the existence of these bases, and where are they, what do they look like, who's in them, etc., etc.? Are there different types . . .

Corey: Yeah.

David: . . . that would be underground or underwater?

Corey: And there's a number of different types that are underwater. I even read about large underwater bases that were mobile, that moved along the bottom of the ocean and was doing some sort of core sampling or testing of the material that it was passing over.

And if you located where one of these were, you would then have to track it since they now were moving. So they would have ships that would just track a mobile underwater base.

David: Well, before we taped this segment, we were looking at just something like that on the Internet. Let's take a look right now at that little . . . This is an excerpt from a video describing something very similar to what **Corey** just described – two-and-a-half-mile wide, round object that seems to be tracing patterns on the sea floor.

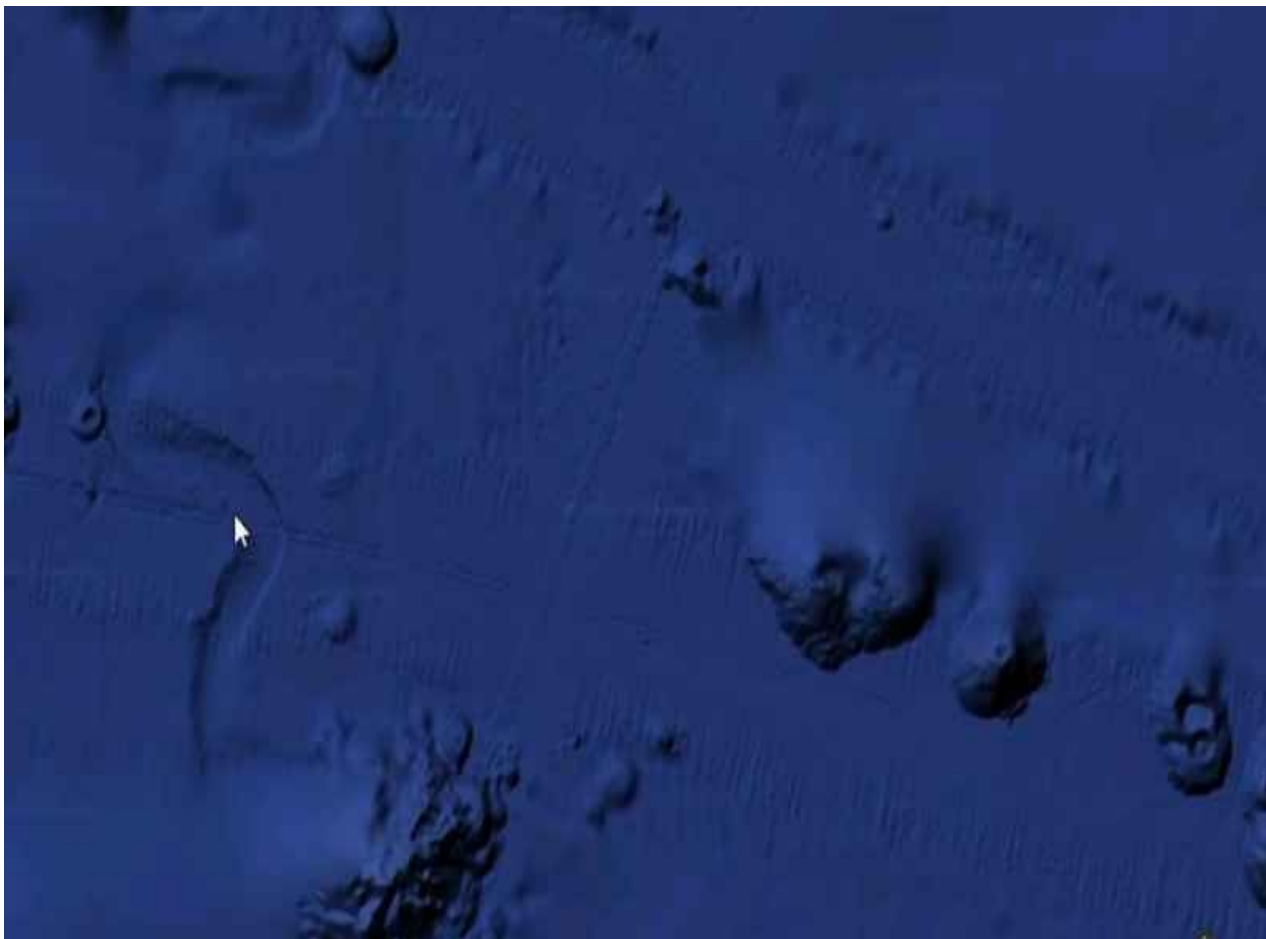

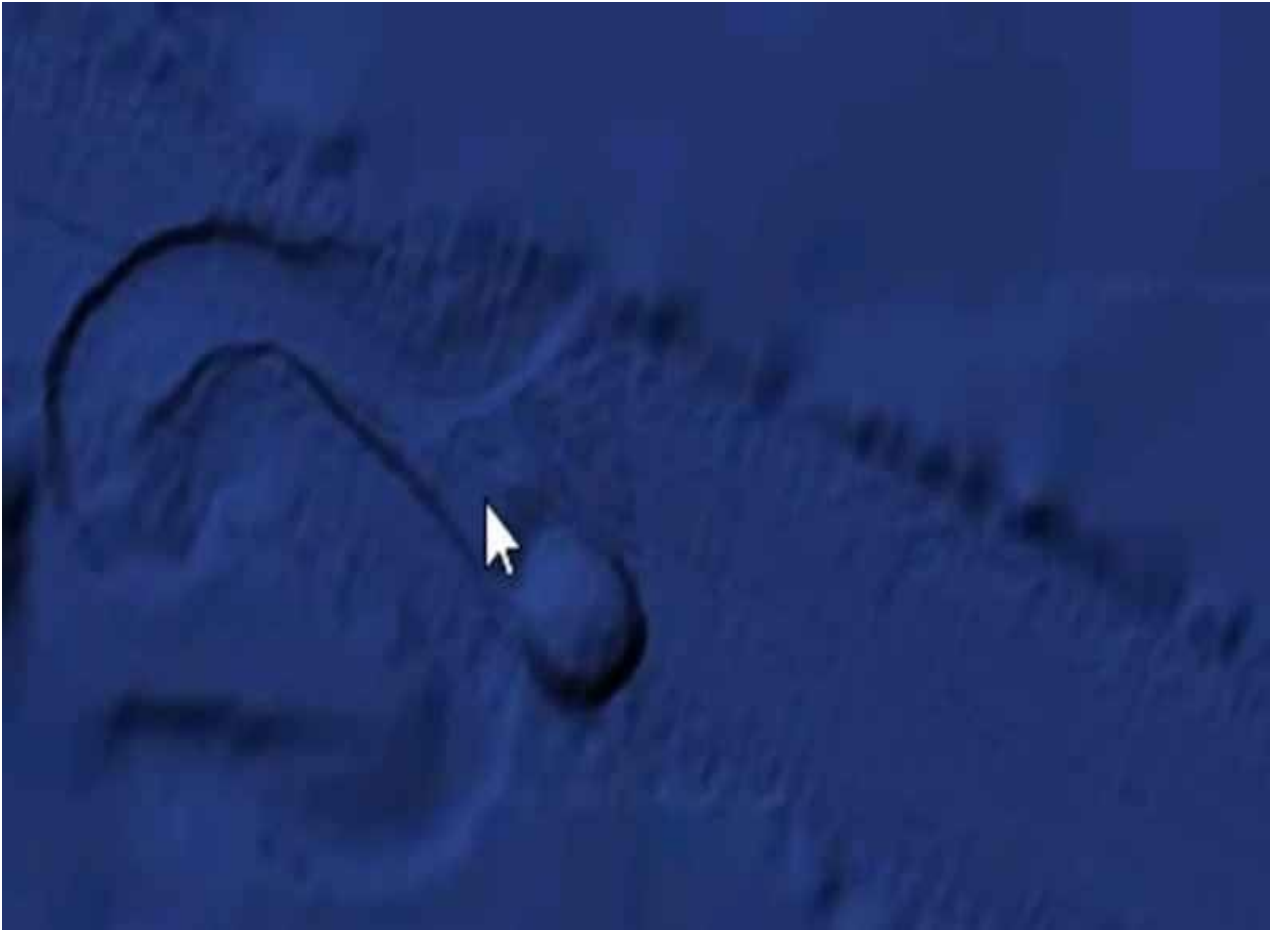

Images from video on possible undersea ET exploration craft

So do you think that that is an example of one of these craft?

Corey: That very well could be. I mean, a two-mile-wide object is not going to be pushed in that unusual way under the ocean by a current.

David: So what would they be doing in a case like that? What's the objective?

Corey: From what I was told, these were like bases, but also laboratories. They were going around doing core samples, finding out what was at different depths below the surface, below the floor of the ocean.

David: Why would somebody want to have an undersea base if there's a honeycomb Earth and they could just pop into one of those combs underground?

Corey: There's a lot of different regions inside the honeycomb Earth that belong to different groups that they claim as their territory.

Also, under the ocean . . . There are a lot of different beings coming here that could care less about us, could care less about any animals flying in the sky or running around. All they care about is the life forms in the ocean and the ocean itself. They see the ocean as a life form. And a lot of these are aquatic species.

David: So what do you think was going on when James Cameron made “The Abyss”? It seems a very specific idea was being conveyed. We also have reason to believe that some of his other movies had disclosure in them as well, like “Avatar”. What do you think “The Abyss” was intended to get people ready for?

Corey: It was most likely groups within the military-industrial complex starting to seed our consciousness, which is what they've been doing through movies and television shows for a long time.

David: Yeah. That definitely makes sense, because this is an ongoing effort of four generations now of disclosure to get us ready for the truth.

Corey: Right. And as you've already reported, when Sony got hacked, it was proven that DARPA and these other groups were passing on ideas for movies and television shows.

David: Exactly. All right. Well, we have one more really exciting piece of footage for you to see here with our interview with **Tompkins**. And this time, he is describing his personal experience with one of the most infamous and legendary events in UFO lore – less known up until recently, a lot less known than Roswell, but several years before Roswell.

We're talking about the Battle of Los Angeles. Let's take a look now.

* * * * *

BATTLE OF LOS ANGELES

Tompkins: February 1942, we were living in a very large home which had been converted to four apartments – two upstairs, two down.



We had a great big enormous deck that ran all the way across this real high-celinged building. So we were four blocks from the ocean, okay? We can't see the ocean, because it's down low and trees are in the way.

So my brother and I are laying on our floor listening to the radio and looking at some papers, and my dad says, "Get out here – out on the deck. Get out here NOW!" And we got up, and we went out to the back deck.

So right above the horizon of all the trees and stuff and buildings is this dot – a white dot. It's just there. And it's got to be some aircraft flying in to come over and land at the airbase, but it's not moving. It's just a bright dot.

And off of this dot, to the left, is a little beam. It's like a pencil beam, but you can see it.



This is out over the ocean, like maybe inside the breakwater, because we couldn't see the ocean, and we don't know how far out it is. It could have been 10 miles out. What in the world was that?

So we're watching it for about five minutes, and then there was a flash – a brilliant flash into our eyes.

It lit up the trees, the back, the side of – everything got lit up.



And it went out.

And we looked and looked and looked, and everything was gone – nothing else. So we went to bed.

12:30 at night, the anti-aircraft guns started firing. What we're talking about is this fantastic situation, the Los Angeles event – the Battle of Los Angeles, okay?

The anti-aircraft guns all started firing.





And, of course, nothing is happening. And it parks there for an hour and a half. While it's parked, hundreds of different types of vehicles – most of them circular, but some cigar-shaped, large ones – came in underneath, being fired on where they're still trying to shoot this thing down.

We go outside. Here's this massive thing right above us this big [Bill holds his hands about 3-ft. apart] – right above us, maybe 7,000 feet.

The anti-aircraft shells are blowing up on the bottom of it all around it. There's eight searchlights all focused on this as they're shooting at it.

They came around him. They came over him – all night long.

Now, it got boring after awhile, so we went to bed at 3:00 a.m. I don't know how it gets boring, okay? We went to bed at 3:00 a.m.

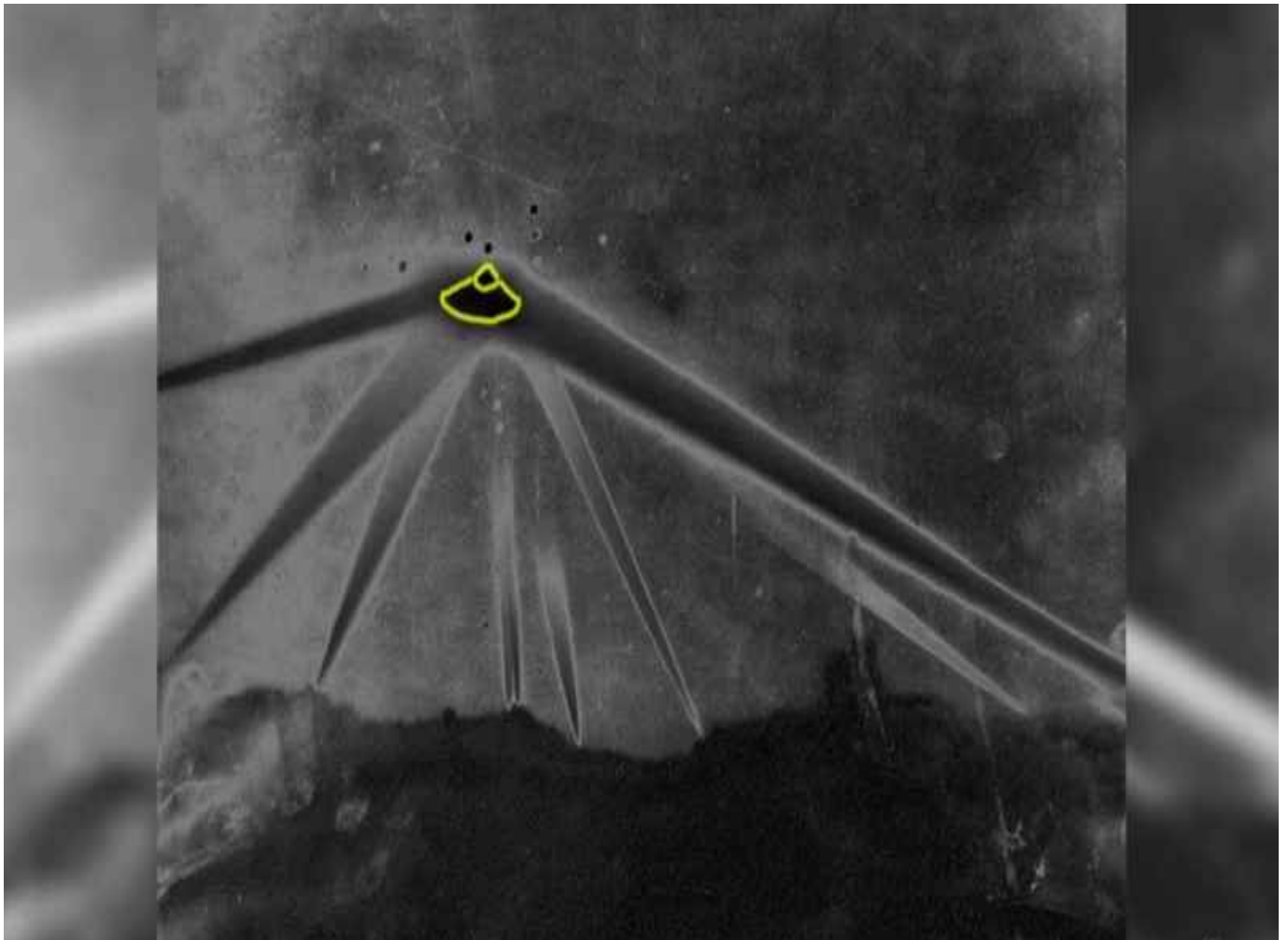



Now, when it started, everybody came outside. All of us are standing there watching this event.

Now, what was not published was that the breakwater is full of Navy ships who used up all of their ammunition that five-hour period – not just the coastal artillery who used up all of their ammunition, okay?

Your whole two Pacific navies, the Eastern Navy and the Western Navy, used up all their ammunition.

They finally quit, of course, just before daylight, and everybody went back inside.

But from the standpoint of all of us out there watching this, nobody got a heart attack. Nobody got sick. Nobody got scared. Nobody got frightened.

On the other side of the planet, London, was being bombed by the Germans. And they're trying to get into shelters.



We had a five-hour war, except they didn't shoot at us. But nobody got sick. The only persons who were actually wounded was from shrapnel. A couple of guys actually were killed.

Almost a million people in California watched an event for five hours of a massive extraterrestrial battle group that came over California with a mission.

* * * * *

David: Well, this is obviously one of the great classic events in UFO lore, something that just can't be covered up. Did you ever hear about or read about this battle on the smart-glass pads or in any of the briefings that you had on the inside?

Corey: I read that it had occurred. The only thing that I saw that wasn't reported here is that during the same time period, we did recover a non-terrestrial craft from the ocean in that general vicinity.

David: Really?

Corey: Yeah. I don't know if that would have been one of these smaller craft that he saw or the large one. To me, it seemed as though they were unaffected by the anti-aircraft.

David: But it is possible that one of them took a stray hit or something and landed in the ocean.

Corey: It could be. Or the Battle of LA craft and these other craft that sound like came out of it could very well have been searching for . . . It might have been a rescue operation.

You know, there's a number of things it could have been. They could have been probing our defenses, or maybe making a point to some of our leaders after a recent meeting.

David: Well, let me run this idea by you. This is something I discussed on “Wisdom Teachings”. It's worth repeating and getting your thoughts.

If you go back to Fatima, Portugal, right after Portugal enters into World War I, which is this horrible, devastating thing where tens of millions of people are dying, ultimately, you have these kids who start to be in contact with what appear to be spiritual beings that ultimately leads to a mass sighting of a silvery disk in which 90,000 people witnessed this thing.

And then they're soaked in rain, but when the whole thing's over they were miraculously dry. The craft appears to shoot rainbow colors all over the sky. 90,000 witnesses . . . That would have been the end of the cover-up if it had happened in our times.

Corey: Right. And a million people seeing this in Los Angeles, and sounds like Long Beach and other areas – today, with everyone having an iPhone, it would – yeah, it would be over.

David: So do you think it's possible that both the Fatima sightings and the Battle of LA could be benevolent groups that are showing us these things as we enter into war, to try to steer us away from warfare perhaps?

Corey: It very well could be, because with their technology, they could have flattened the whole city with very little effort.

So they were obviously not there for some sort of offensive operation – maybe an intelligence operation, rescue recovery operation, or there to make a point. But I really don't know exactly why this

incident occurred.

According to what I've heard, there was some treaty signed that this type of open sighting, open mass sighting, is against a treaty.

David: Right.

Corey: So there had to have been a good reason why it happened.

David: Now, we've heard from guys like Benjamin Fulford in some of his disclosures that he was told by Pentagon insiders that 75% of all production money for Hollywood films is coming from the Pentagon through various backdoor firms.

So let me just ask you first if you have ever heard anything like that?

Corey: Oh, yeah. Yeah. A lot of money from the DoD (Department of Defense) and Pentagon is going in for propaganda.

David: So why do you think the Battle of Los Angeles movie would be made? Do you think maybe they're confusing people's Google search so that they're going to find this movie instead of any real information?

Corey: Well, they know that that was a very significant occurrence UFO-wise in American history. Nearly a million people saw it.

David: Right.

Corey: So it was already in our consciousness. So that's a tool for them. And they – they being different military intelligence groups – are trying to spin the narrative that all of these beings coming in are negative, and that they are here to invade. And this one obviously wasn't, because it didn't attack.

David: Do you think maybe creating a movie with the same title blocks people from finding the original incident at all?

Corey: It could do that, or it could just put the whole sci-fi spin on it to where . . . You know, we're already programmed to roll our eyes any time we hear anything alien or UFO. That's probably part of the effort.

David: I was fortunate enough at one of my conferences to have a woman stand up who was a little girl during the time that this happened and witnessed the entire thing. And it was quite fascinating.

We let her speak for some time to the audience. It was quite spontaneous.

The point is, a million people is a lot of witnesses. It's kind of amazing that we still have a UFO cover-up after something like that.

Corey: Yes, but the propaganda and the programming that has come from these intelligence groups has been very effective. So there's a good chance that if something like that happened today and we didn't get photos, a lot the people that witnessed it themselves would, after a few days, be like, "Oh, that didn't happen." Or just forget about it and move on.

David: Well, another interesting thing regarding the Battle of Los Angeles is the "War of the Worlds" broadcast. The original broadcast with Orson Welles was in 1939. But then when the movie came out, it was after this had happened. And we have multiple eyewitnesses saying that the craft that you see in the "War of the Worlds" movie is very similar to the one in the Battle of Los Angeles, except that it has a little periscope on the top.



So why do you think they would actually put the real craft into the movie?

Corey: Well, they're always hiding things in plain sight. So if you were to see something similar to "War of the Worlds", on some level you might be willing to discount it, thinking, "Oh, that's military, or that's some concept that's being used for a movie".

You're going to jump to that instead of aliens automatically. That's possible.

David: Well, do you think also that putting those exact same craft into "War of the Worlds" where they become hostile attackers . . .

Corey: Oh, yeah.

David: . . . instead of peaceful demonstrators, could be like a form of mass mind control?

Corey: Well, sure. If you see a certain craft design and see it destroying cities in a movie, well, if you see it in real life, what are you programmed to think?

They could be coming down to say, "Hello", and maybe give you a ride and show you around the solar system, but you've been programmed to run and hide because you think that it's an invasion.

David: Exactly. Do you think it's possible that we could have another mass demonstration like that at some point that there could be another event like that if, for example, this Mohammad Treaty gets overturned?

Corey: Absolutely. If the treaty that's supposed to prevent that is overturned, there are a lot of non-terrestrials that want to be up in the sky and over populated areas to let us know that they're here.

David: Now, you also mentioned in some of your recent briefings that both the SSP Alliance and the Cabal are concerned about the possibility of wreckage crashing into a major American city.

So just real briefly, since we're talking about these battles in the air, what are they thinking would happen, and how would that play out on the world stage?

Corey: Well, they're afraid that some of their weapons platforms that have been up in orbit, and advanced craft, could possibly fall into a populated urban area with all of the activity that's going on up there. There are shootdowns happening.

So they are ready to pounce on any crash. They have cover stories in place saying, “This was a nuclear-powered satellite that crashed. It's contaminated a large area. So stay in your homes or leave the city.”

And then they will focus on cleaning up the debris.

David: So this is something that they're actually very concerned about.

Corey: Absolutely. That is . . . I've heard a number of times that they're worried.

David: Are there more battles happening in our atmosphere now than there were before between these cloaked craft?

Corey: Yes. It's kind of reached a crescendo in recent times. There are human-piloted craft fighting each other, human-piloted craft fighting non-terrestrials and different non-terrestrial groups that are having skirmishes.

David: So what would we expect if they tried to cover this up? What would be the kind of headlines we'd see or the stories we'd hear?

Corey: Just like the example I just gave, that some sort of secret satellite had crashed or something like that. They're not going to say a UFO crashed.

David: Or a nuclear event . . .

Corey: Right.

David: . . . maybe a nuclear waste dump or spill

Corey: Test craft.

David: . . . chemical emission. Something like that.

Corey: Right. Something that's going to scare people.

David: Right.

Corey: Like some sort of disease or any number of things.

David: All right. Well, you saw it here first. This is “[Cosmic Disclosure](#)”. I'm your host, [David Wilcock](#), here with **Corey Goode**. And we're reviewing footage from **William Tompkins** – absolutely mind-blowing stuff.

Thank you for watching, and we will see you next time.

Cosmic Disclosure: The Law of One and The Secret Space Program

Season 6, Episode 9

David Wilcock: All right, welcome to “[Cosmic Disclosure](#)”. I'm your host, [David Wilcock](#), and in this episode we're going to start verifying some of the things that **Corey** has been telling us with empirical data. And there are various ways this has been coming in.

We did some episodes of **William Henry** talking about ancient art work and how it shows Blue Spheres, it shows Blue Avians.

We've got a new whistleblower, **William Tompkins**, who's come forward and validates many of the things **Corey's** saying. And now, also, we have The Law of One material, which has some unbelievable pay-offs of everything you've been hearing in this show.

So, **Corey**, welcome back.

Corey Goode: Thank you.

David: Since what we're about to discuss is going to be really mind-blowing for most people, the amount of correlation that's in The Law of One to what you personally encountered in your job, let's just talk about did they know about The Law of One in the Space Program, and if so, what was their opinion about it?

Corey: Yes, The Law of One was definitely known about. And certain individuals were required to read it. I was told that it was negative material and stay away from it. Stay away for it.

David: Ha, ha, ha.

Corey: And I did. I stayed away from it. I think in the early 2000s it was online, and I scrolled through and looked at a little bit of it, and that was the extent of it. But I never dug in and read it because I was somewhat programmed that it was, you know, something to stay away from.

David: Now, there were other people who we spoke to as whistleblowers who independently verified that as well, that they knew about The Law of One and the Secret Space Program. It's a common factor.

Corey: And if you recall that was one of the questions that one of the SSP Alliance asked Raw Tear Eir is, “Are you the . . .

David: “Are you the Ra from The Law of One?”

Corey: Right.

David: And then he just answered, “I am Ra.”

Corey: “I am Raw Tear Eir.” That is just all he said back.

David: And in every question that they answer in The Law of One, they always start . . . The first statement they make is, “I am Ra.”

Corey: Right. And all it did was confuse the audience, because they didn't . . . They were like, “Okay, he doesn't want to answer the question.”

David: So, in this episode, we're going to be getting into a deleted piece of material – there was an entire session, Session 8, that came through on January 26, 1981. That whole session was deleted from The Law of One because Dr. Don Elkins, the guy asking the questions, didn't know that this was possible.

It was so far out . . . What The Law of One told him about our government and the technology they have and the extent of it totally blew his mind. He couldn't tolerate that this was real and they said, “This is . . . We're going to have to ask a lot of questions about this if it's true. So we better just remove it from the books.”

So the people in the Space Program haven't seen this either. This only came out on the website a few years ago. It was actually in Book Five. I correct myself. It was in Book Five as of 1998. That's the first time anybody ever saw it. Now you can read it online.

Okay, so check this out. Let's read some things here.

LAW OF ONE ON SSP

[8.2](#) Questioner: [Yesterday you said] “There is a certain amount of landing taking place.

“Some of these landings are of your peoples; some are of the entities known to you as the group of Orion.” [Now, that's the Draco.]

My first question is what did you mean by the landings are of your peoples?

And when they're talking about “landings” here, they're talking about UFOs. So check out what happens here:

Ra:... Your peoples have, at this time/space present, the technological achievement, if you would call it that, of being able to create and fly the shape and type of craft known to you as unidentified flying objects.

Now, this ends up totally hitting Don by surprise. He did not expect this.

Unfortunately for the social memory complex vibratory rate of your peoples, these devices are not intended for the service of mankind, but for potential destructive use.

This further muddles the vibratory nexus of your social memory complex.

[This causes] a situation whereby neither those oriented towards serving others nor those oriented towards serving self can gain the energy/ power which opens the gates to intelligent infinity for the social memory complex.

So what they're really saying here is the Ascension is confused by the Space Program. It's not like they're doing . . . They're not doing themselves a favor. They're not doing us a favor, because they're not sharing the technology.

Corey: Right. The technology that could help us progress.

David: But you say now this Alliance does want the technology to come forward.

Corey: Absolutely. Their goal is to bring the technology to all of humanity no matter their race or creed or religion at the same time.

David: And you can see, **Corey**, from this that they're saying if that technology was released, it would have a very positive effect on the Ascension process.

Corey: It would be a different world.

David: Yeah, absolutely.

This in turn causes the harvest to be small.

So that's pretty shocking right there. It's just saying we've been so compromised, the number of people who have become loving enough to graduate is not that big.

Okay, now we going to really get into the details of this, and it's quite stunning how much this validates everything that you've said.

[8.3](#) Questioner: Are these craft that are of our peoples from what we call planes that are not incarnate at this time?

He can't grasp what's really happening here.

Where are they based?

Ra: . . . These of which we spoke are of third density and are part of the so-called military complex of various of your peoples' societal divisions or structures.

They don't use the word 'industrial'.

Corey: Right.

David: Isn't that amazing though? The wording that they use: military complex. So they are saying this is physical people building unidentified flying objects. And remember mainstream UFO study back in 1981 when this was done, nobody was on to this yet.

What was the state of the Space Program in 1981?

Corey: In 1981, that was the beginning of Solar Warden. Solar Warden was just beginning to really get started. But there were other programs that had already started before World War II that were well, well-developed.

David: But there were plenty of unidentified flying objects by 1981 . . .

Corey: Oh, yeah.

David: . . . in the military complex.

Corey: Right.

David: All right. Let's go on.

The bases are varied.

They talk about bases. Listen to this.

There are bases, as you would call them, undersea in your southern waters near the Bahamas as well as in your Pacific seas in various places close to your Chilean borders on the water.

Corey: Ha, ha.

David: Now, you laughed when we said "Bahamas". So how does this line up with anything you've heard?

Corey: I saw maps of underwater naval bases in the Bahamas.

David: Okay. In the Bahamas. And what about off the border of Chile, which is down closer to the bottom of South America?

Corey: I know that there are bases down there that are military, but I don't know whose they are. They may be more of the German breakaway faction.

David: Yeah. I would think so too, because they went to South America. So undersea bases, and then look at this. I mean unbelievable in 1981, January.

There are bases upon your moon, as you call this satellite, which are at this time being reworked [January 1981].

Corey: Bases that are being reworked?

David: On the Moon . . . by the military complex.

Corey: “Bases that are being reworked.” Does that indicate that they occupied a base that wasn't theirs and are retooling it?

David: Well, they don't explain that, but I think what they're saying here is there's a massive industrial expansion.

Corey: Hmm.

David: Now, think about . . .

Corey: ICC.

David: Think about what you said about the Lunar Operation Command.

Corey: Right.

David: Right. Does your knowledge verify that there was some sort of major upgrade to the LOC . . .

Corey: Yes.

David: . . . starting with the Reagan administration?

Corey: Yes. And also the building of the Dark Fleet base.

David: Right.

Corey: And there are several other smaller outposts that they don't really call bases.

David: But that's just way beyond, you know, anything that people thought they knew at the time.

There are bases which move about your lands.

Now that probably means some kind of mobile vehicle thing like a drivable base. Would you say that there are things like that – bases that can be driven around like people working inside a truck or something like that?

Corey: I know of mobile command centers.

David: Okay. That's probably what they're talking about.

There are bases, if you would call them that, in your skies.

Corey: That's probably the same thing.

David: Orbital platforms?

Corey: Orbital platforms or command stations that are craft that will fly over certain areas, cloak and stay in position to monitor and relay telemetry.

These are the bases of your peoples.

[They are] very numerous and, as we have said, potentially destructive.

David: So there again, they're talking about bases on the Moon. They're talking about orbital platforms, and they're saying these bases are very numerous. This is unbelievable.

And as you see here in a second, the questioner totally balks on this. He can't handle it.

[8.4](#) Questioner: Where do the people who operate these craft come from? Are they affiliated with any nation on Earth? What is the source?

This gets interesting too.

Ra: These people come from the same place as you or I. They come from the Creator.

Now, that's Ra being blustery.

Corey: Yeah. We're all One.

David: Yeah. They don't want you asking these kinds of questions, but now 30 years later, 35 years later, it becomes very important.

As you intend the question, in its shallower aspect, these people are those in your and other-selves' governments responsible for what you would term national security.

So once again, Don just couldn't believe that the Space Program existed as you now have told us it was there at the time, because there was no information in ufology about this.

Corey: I don't think any information about the Secret Space Program really came out until, what was it, the '90s?

David: Yeah, at least. Now, notice that it says “other governments”. So what do we know about the Global Galactic League of Nations? Do we know when that got started? Because they're already saying here that there were other governments involved in national security stuff in space as well.

Corey: Well, they could be referring to that and that occurred in the '80s as well.

David: Oh.

Corey: But they may be referring also to the ICC, Interplanetary Corporate Conglomerate. They're made up of corporations based in many nations.

David: Right. So now check out . . . He's really having trouble with this, especially the undersea bases.

8.5 Questioner: Am I to understand then that the United States has these craft in undersea bases?

Ra:...You are correct.

8.6 Questioner: How did the United States learn of the technology to build these land [and sea bases and craft]?

Ra:... There was a mind/body/spirit complex known to your people by the vibratory sound complex, Nikola.

Of course, they're talking about Tesla.

This entity departed the illusion and the papers containing the necessary understandings were taken by mind/body/spirit complexes [that means 'people'] serving your security of national divisional complex.

So they are basically saying here that there was some kind of Tesla connection. Does that verify anything that you've heard on the inside?

Corey: Well, yeah, Telsa in his electrical and electromagnetic research was way ahead of his time, and when he passed away, all of his information – it was documented – all of his information was taken away, made classified and put into the programs.

But I had not heard that all of the technology was based on his research. I'd presumed that it would have been reversed alien technology or gifted alien technology.

David: Hmm. But we certainly can see that if Tesla . . . If the eyewitness accounts of him having a flying disk are correct, that he would have had the capability . . .

Corey: Yeah.

David: . . . his papers would have had the capability to build the Solar Warden-type craft in the aftermath.

Corey: Sure.

David: Yeah.

Corey: They had enough scientists.

David: All right. Well, let's go on here.

Thus, your people became privy to the basic technology.

In the case of those mind/body/spirit complexes which you call Russians, the technology was given from one of the Confederation [that's the positive folks] in an attempt, approximately twenty-seven of your years ago, to share information and bring about peace among your peoples. [1953-54]

So that gives us a window. 27 years is like 1953 or 1954, and what they're saying here is a benevolent extraterrestrial group contacted the Russians.

Corey: That's right during the time frame also when a benevolent group came and contacted the United States military complex and warned them of the path they were taking and tried to give them assistance to deviate from it.

David: And they talk about that in The Law of One. They talk about meeting with Eisenhower, offering him a peaceful plan and that he rejected the plan.

So it's clear that they don't want to play favorites here. They gave it to both sides at once.

Corey: Was this information out in . . .

David: No. There was nothing in the public about Russians getting UFO technology in 1953.

Corey: There was no Internet or way to disseminate it.

David: I've never been able to find any research that validates this, but, again, the Russians are competing with the U.S., so they're not going to share that this happened.

Corey: No.

David: But as we go on, we see that it did not work out well with the Russians either.

The entities giving this information were in error, but we did many things at the end of this cycle in attempts to aid your harvest [ie Ascension] from which we learned the folly of certain types of aid.

So, again, the Russians got the technology. They're not using it for peaceful purposes. They're creating weapons of war.

Now, are you aware of the Russians having their own craft as well going far back in time like to the 1950s?

Corey: Yes.

David: Could you tell us a little more about that?

Corey: They were developing their own programs based on information that they had gotten from [Project] Paperclip people. They were developing technology from all different sources.

David: Including the Germans, as you said.

Corey: Including the Germans. And they had developed several different type of spherical craft and a few others that they were already flying in the skies before the Americans really . . . They were ahead of us.

David: Hmm.

Corey: And it was very concerning to the military factions of the early Secret Space Program. There was a lot of weird incidents that were making us have setbacks in our program that didn't make sense. We couldn't figure it out.

We were having some problems like there was something going on that was preventing us from getting started as early as we could have.

David: Well, it's interesting here that the Confederation gave them a boost in the hopes of creating a peaceful outcome.

Corey: Yeah, it's . . .

David: They must have seen that the Russians were a counter-measure against the Cabal potentially.

Corey: Is this a group associated with Ra or whatever?

David: Yeah. The Confederation is their positive association of civilizations that are trying to promote Ascension and a benevolent outcome.

Corey: That's definitely direct intervention.

David: Yeah. And they screwed up, because the Russians took it the wrong way.

That [these errors] is a contributing factor to our more cautious approach at this date, even as the need is power upon power greater, and your people's call is greater and greater.

So this is why, also, they stopped landing and bringing people on board in person, like the benevolent ET stuff that happened in the 1950s with the positive contacts. They explain in here that they don't bring people up any more.

But we do know the abductions stuff was happening and they definitely get into that.

Okay, so he's still really having trouble with this. Check this out.

[8.7](#) Questioner: I'm puzzled by these craft that we have undersea bases for . . .

Is this technology sufficient to overshadow all other armaments [on Earth]?

Do we have just the ability to fly in these craft or are there any weapons like there are . . .

Were they given to us [inaudible] or are they just craft for transport?

What is the basic mechanism of their [inaudible]?

So he's really trying to find out now, is this a superior military force to anything on Earth. Now before we get the answer, what would you say?

Corey: They are a breakaway technology. They're definitely weaponized craft.

David: Right. And you've never seen this before, right?

Corey: No.

David: So you don't know what they're going to say, but it's the same thing.

** It's really hard to believe is what I'm saying.*

He's having a lot of trouble with this.

Corey: This person asking the questions, is he a UFO skeptic?

David: It's Dr. Don Elkins who is a very well-read ufologist and a PhD physics professor who's been studying this stuff since the early 1950s and it's now in the 1980s.

Corey: Okay.

David: So he's been doing 30 years of research. So then they say:

Ra:... The craft are perhaps misnamed in some instances.

It would be more appropriate to consider them as weaponry.

So let's just stop right there for a second.

Would you say that this is accurate in terms of all the craft that our military-industrial complex was building had weapons systems on them in varying degrees?

Corey: Not all, but most of them are what . . . are referred to as weapons systems.

David: Really?.

Corey: Right.

David: There you go. It's amazing.

The energy used is that of the field of electromagnetic energy which polarizes the Earth sphere.

So they're talking about electro-gravitics, I think.

Corey: Exactly.

David: Particle beams.

The weaponry is of two basic kinds: that which is called by your peoples psychotronic and that which is called by your peoples particle beam.

Corey: Psychotronic?

David: Yes! And do you know what that is?

Corey: I'm wondering if it has to do with what we've just discussed before the technologically-aided remote viewing and influencing used as a weapon?

David: Exactly.

Corey: Is that what it is?

David: “Psychotronic” means electronics that interface with the mind.

Corey: Whew! And many of the craft are bio-neural interfaced - the weapons systems.

David: There you go. So what they're really saying here is 'psychotronics' mean technology that can control how people's minds work. Technology that can make people upset, that can make people anxious, create mass hysteria, that kind of stuff.

Here it is in 1981. It's unbelievable. And particle beam technology.

The amount of destruction which is contained in this technology is considerable.

The weapons have been used in many cases to alter weather patterns and to enhance the vibratory change which engulfs your planet at this time.

Corey: I was just about to ask if HAARP had anything to do with this.

David: Now, you've got to understand . . . What does “vibratory change” really mean? They're talking about Earth changes.

As the planet's vibration changes, you get volcanoes and earthquakes. So they're totally, in 1981, describing HAARP, weather modification and then also microwaving the fault lines to get earthquakes.

Now, are you aware of their being HAARP-type technologies on these orbital platforms or spaceships? Could they do it from the spaceships?

Corey: Absolutely.

David: Okay. Now, I've never heard that before. That's why I want to do this live. Because I'm just throwing us in. I didn't know what you were going to say.

Corey: Yes. They can . . .

David: So they can?

Corey: Yeah.

David: It's not . . . Because most people think it's just satellite arrays on the surface of the Earth.

Corey: They can cause localized weather events and they can cause earthquakes. They can cause molecular changes in structures to cause them to fail – catastrophic failures.

David: Right.

Corey: There's a lot they can do from orbit.

David: And it is interesting, if you've ever seen that movie with Mel Gibson called “Conspiracy Theory”. Right at the beginning of the movie they have this space shuttle in orbit beaming down stuff that changes the weather and controls people's minds at the beginning of the movie.

Corey: Seriously?

David: This is just mind-blowing. It's right there. All this stuff that we talk about now in 1981 – way before anybody was talking about this.

Now he's just still reeling from this.

8.8 Questioner: How have they been able to keep this a secret?

Why aren't these craft in use for transport?

Because he's a pilot, right? That was his money-making job was to be a pilot. Why aren't they using this?

Ra:... The governments of each of your societal division illusions desire to refrain from publicity so that the surprise may be retained in case of hostile action from what your peoples call enemies.

Now, notice, again, they're talking about multiple governments.

So do you understand that? You look a little puzzled.

Corey: I'm a little puzzled.

David: The verbiage gets dense sometimes.

Corey: Yeah.

David: What they're basically saying is that the governments of the world, including other governments, because remember, this is multiple governments, they're not going to tell us because they're worried about an alien invasion.

They want to preserve the element of surprise. They don't want rogue alien groups to know that they have this technology – these bases on the Moon, under sea, orbital platforms, weaponized craft, so they have the element of surprise if they get invaded.

Corey: But they already know.

David: But there could be groups that didn't know.

Corey: Right.

David: Yeah.

Corey: Yeah, the interlopers that come in.

David: There you go.

Corey: We have people come in that haven't fully reconned.

David: Right. I think that's what they're talking about here. It's really fascinating.

[8.9](#) Questioner: How many of these craft does the United States have?

Now this is very important. He said “United States”.

Corey: Right. He didn't say “governments”.

David: He didn't say “military-industrial complex”, and we're already dealing, as you said, with a breakaway civilization – the ICC. How far along were they at this point, 1981?

Corey: They were pretty far along. They had developed a lot of the technologies and were figuring out how to disseminate it to some of these other fledgling programs.

David: Was the United States still in control of the ICC by 1981?

Corey: The U.S. is not in control of the ICC.

David: That's what I wanted to have you say.

Corey: Right. The ICC is some super board made up of retired members of all these different military complex companies . . .

David: Right.

Corey: . . . from different countries that are part of the board that make decisions that no one in the, or hardly anyone in the, American government will ever hear about.

David: So the point here is that if they ask . . . You've got to be really careful how you ask the question. The United States by 1981 . . . Would you say that the only thing that the United States is actually controlling might be like the lower-level military space program?

Corey: Right.

David: Okay. That's what I thought, because this doesn't quite line up with everything else. Because as it turns out, what they say here is the only stuff the United States was controlling in 1981 directly was robotic unmanned weapon craft. And that comes up here.

[8.9](#) Questioner: How many of these craft does the United States have?

Ra:... The United States has five hundred seven three, five seven three [573] at this time.

How does that line up with anything that you know? You've never seen this before.

Corey: That's not a stretch of the imagination if they are including drone craft, which they had very early on.

David: Right.

Corey: There was a lot that they were trying to overcome with shielding in outer space for astronauts or space program participants, so there could have been a very large number of unmanned craft.

David: There you go.

They are in the process of adding to this number.

[Other countries are not mentioned, including Russia] nor breakaway military complex.

8.10 Questioner: What is the maximum speed of one of these craft?

Ra:... The maximum speed of these craft is equal to the Earth energy squared.

This is one of these weird things they don't really explain. So we don't really know what that means except that it's somehow drawing off of energy fields from the Earth as it moves around the Earth.

This field varies. The limit is approximately one-half the light speed, as you would call it.

This is due to imperfections in design.

Are you familiar with there being drone craft that may be at a lower-level space program level that would not actually be able to get past half light speed unless they go through the Cosmic Web let's say?

Corey: Yes. Many of the craft in the beginning that were traveling from sphere to sphere within our solar system they would not be making a trip to Mars in a matter of 20 to 30 minutes. It would take them hours.

David: Right. Exactly.

Corey: And they had to overcome some technical issues and make some scientific breakthroughs before they were able to go superluminal.

David: It fits perfectly.

[8.11](#) Questioner: Wouldn't this type of craft totally solve, or come close to solving, a lot of the energy problems as far as transport goes?

Ra:... The technology your peoples possess at this time is capable of resolving each and every limitation which plagues your social memory complex at this present nexus of experience.

That is a stunning statement. Would you agree with that?

Corey: It's a very true statement. I know that to be fact from my own experiences.

David: We have all kinds of problems. We have all this space junk around orbiting the Earth that's a big problem if we ever try to go out in space more. We have gigantic oil spills. We have huge gyres in the ocean of junk plastic that all needs to be cleaned up. Radioactive waste.

Corey: That doesn't even count, you know . . . People dying of diseases every day they don't need to be. Hunger. People going without water. You know, the energy, the so-called energy crisis that you hear about on the news. None of that should exist.

Those are all crimes against humanity in my book that they are still occurring with the technology that we have available.

David: And isn't it stunning that this was brought through in 1981. Nobody ever got to see it. I bought Book 5 as soon as it came out in 1998. And it was already in there.

Corey: It is definitely . . . It's amazing. It's amazing, yeah, that this information was being delivered to . . . I just wish he knew . . . he had asked some different questions, because we could have really gotten some pertinent information for these times.

David: Well, there's a lot more, but that's all the time we have for in this episode.

Corey: Okay.

David: But you're pretty blown away, huh?

Corey: Yeah!

David: You've never seen this before?

Corey: Yeah, I'm pretty surprised. I thought there were going to be some correlations.

David: But not this much.

Corey: Right.

David: All right, cool. You saw it right here first. This is his live reactions to seeing Law of One data that validates the Secret Space Program. This is [Cosmic Disclosure](#). I'm your host, [David Wilcock](#), and I thank you for watching.

[Cosmic Disclosure: Guiding Humanity to Ascension](#)

Season 6, Episode 10

David Wilcock: All right, welcome back to “[Cosmic Disclosure](#)”. I'm your host, [David Wilcock](#). I'm here with **Corey Goode**. **Corey**, welcome back to the show.

Corey Goode: Thank you.

David: So when we were last talking, we had you going through some very interesting experiences where you were taken to Venus. You met with this being called the Sentinel.

You were given an opportunity to know who you were, who you are, and who you will be, which you turned down. And we did have some negative comments come up about that in which people think that you're trying to paint yourself as a savior figure, that who you will be is a tease for the 'messiah' or something like that.

Corey: No.

David: So could you please clarify that, because that has created some confusion?

Corey: Sure. They have this information for every individual. It's not saying that I or Gonzales are lifted above everyone else.

David: Right.

Corey: Everyone else is going to be given this opportunity at some point to know who they were, who they are, and who they will be. Since they don't see time in the linear way that we do, and Tear Eir has stated that when we do reincarnate, it's not always in a linear way.

Sometimes we reincarnate backwards for experiences. So this was basically an offer of a life review, not an offer of revealing to me that I'm some sort of a messiah.



David: Some of the attacks have said that your humility is false and that you're actually just trying to act as though you were humble while, at the same time, trying to build yourself up as some sort of planetary savior figure.

So I understand that what's happening to you is very authentic. What is the reason for why you don't want to know this information about yourself exactly?

Corey: Because it was communicated to me that it would change the nature of all of my relationships in a very serious way. So learning this information may change me to a point to where I'm not going to be the same person with my family or friends. And a lot of people don't understand that. They're all about, "I want to know the information." You know, "I don't care what the consequences are." But I am very much a family man, and my kids and wife are very important to me.

David: So can you just say for the camera right now that you do not see yourself as a savior figure and that you're not going to try to change that in the future?

Corey: The whole message is for people to stop looking for savior figures, to start looking inside and become your own savior. That's what the message is, and that's what I'm living by.

David: So now that we've established this, after you had the experiences in the last update, including these interesting contacts, you've had the Blue Avians telling you that solar energy is ramping up, that we're going to start to see ghosts appearing, and that that's when we know that things are close is people are going to see ghosts.

What's the next thing that happens to you that we haven't covered?

Corey: Almost immediately after I left here after taping the last updates, I was flying home, and then I was going to go to Sedona to do the SSP Conference. Well, that night I was home, I was picked up and deposited on one of these Blue Spheres, and, again, off in the distance, I see Tear Eir standing.

And as usual, I look up, because I want to see whatever changes I can see in that cosmic scene that I've described to where I can see the Sun, the Earth, sometimes the Moon, depending on its position, and all of these Blue Spheres spread equidistantly out throughout our solar system.



And I had been seeing this electrical corona around the outside of the Sun that was going out a little ways, and then seeing electricity hitting these spheres. It looked like electricity being exchanged between the spheres.

David: You've kind of described that before, I guess, but was this more dramatic or more significant-looking?

Corey: Yes. On this occasion, for a few reasons. When I looked up, the Blue Spheres, the ones closest to me that I could see the best, were even more translucent than last time, as if they're fading out of existence.

David: And they had told you, right, that they were eventually going to fade out completely once we go through this.

Corey: Exactly. Exactly.

David: Okay. So what was different about these energetic phenomena this time?

Corey: On the outside of the Blue Spheres, it was rippling. There was rippling going on like a water effect when you throw a bunch of rocks into a pond, and you see just crazy rippling going on. That was going on, but it wasn't in synchronicity between the spheres.

Some were getting hit more, some less, and it looked like there was some sort of solar wind or kind of like sound waves when they hit the water.

They were just pulsing like, bz-bzz, bz-bzz like something's hitting them.

David: But this is after, as you said in previous updates, that the Draco mind control grid has already had to be turned up to maximum in order to try to keep our consciousness suppressed.

Corey: Correct.

David: So this is suggesting even more dramatic energetic changes that the mind control grid's not going to be able to stop.

Corey: Right. Yeah.

David: Okay.

Corey: These Blue Spheres, the way they're reacting now to this energy output, there's definitely an increase.

David: And you never saw them burble like water before?

Corey: I'd seen the ripples before, slight, but not this dramatic.

David: Okay.

Corey: Another thing that I noticed was there were large metallic spheres that were moving from the outer solar system slowly in, and . . .



David: Metallic spheres?

Corey: Metallic, large, metallic spheres.

David: Large as in how large?

Corey: I had no . . . They were not next to something to where I could get a base of reference, but they looked huge like maybe a third the size of the moon. But I'm speculating, because it wasn't next to something that I could use to compare it.

David: What could that possibly be?

Corey: Well, once when I looked at that, I turned around and looked down . . . to look back down at Tear Eir. And I caught him right as he was gliding in to come closer to me.

And I asked him, I said, "What are those metal spheres?"

And he said that there are other members of the Confederation that are here for a certain task, and they're preparing.

David: And Tear Eir didn't give you any information as to what they were going to do?

Corey: No. It's almost like he changed the subject or had better things to talk about.

David: Is it possible that these could be some form of arcs so that when we go through this change that certain people on Earth are going to be relocated ethically to other planets that'll be more appropriate for them if they can't handle the Earth's rise in vibration?

Corey: That wasn't communicated to me, but that's very possible. That's very possible, because they . . .

David: It does say that in The Law of One that there's a three-way split. You have negative people going on a negative timeline, positive people going on a positive timeline, and people who are not ready for the Earth's new vibration get relocated to other third-density planets.



Corey: Hm.

David: So that could be what this is.

Corey: Could be.

David: So what happens next?

Corey: He moves in. He greets me in his normal greeting and states that we need to cover this topic of the 300,000. He stated that after we had released the information, the manner in which it was released had caused a lot of anxiety and confusion, and that humanity or the people that were confused had put out a call for clarity.

David: First of all, let's just get into what do you mean by 300,000 in case somebody didn't see that episode or doesn't understand?

Corey: When I was interfacing with Tear Eir the previous time, I was wondering how many people were ready to ascend.

And his response at that time was "less than 300,000". I reported it, and then also, some math got kind of wonky.

David: Well, I tried to calculate what percentage of humanity that would be, and then when we somehow translate it to writing, we lost one of the zeroes. It was going to be 0.0045, and we changed it to 0.045, I think is what happened.

Corey: Yes. I got many emails on that. Yeah, there was some confusion in the delivery.

David: Okay.

Corey: He started communicating and bringing me back to that time to when I had that original question about how many people would be ready to ascend. And he stated that "In your current temporal reality at that moment, that is how many people were ready to ascend, and that that number is in constant flux."

Our temporal reality right now is being decided upon, and there are constantly changes that are occurring because of us and our co-creative consciousness.

David: When we look at the meditation effect – I've talked about it on the “Wisdom Teachings”, 7,000 people – there's 39 studies of varying numbers of population like this, but the core one is 7,000 people get together and meditate.

And worldwide, war, crime, fatalities, terrorism, decreases by an average of 72%, showing that a very small number of people going a lot more positively can have this hugely disproportionate effect on everyone's consciousness.

So do you think it's possible that, perhaps, a small number of us like the number watching this show, which is way in excess of 7,000, that if we started to do our homework and be a lot more positive on a daily basis, that we could significantly increase that number by this radiant effect throughout the whole planet?

Corey: Absolutely. And one of the things that popped up the most in people's reactions were, how can the number be so low when there are millions of children on the planet?

David: Yeah.

Corey: Aren't most of them at least under some sort of age of accountability? And Tear Eir stated that there have never been, in the history of our planet, there have never been more wanderers on the planet than there are currently at this moment, and that most of the children that are here today are here to go through this experience and bring a loving vibe and help us through this consciousness transition that we're going through.

So a lot of the beings that are left out of that 300,000 number are wanderers, are people that are here from other soul groups that are trying to assist us in this great transition we're going through.

David: Most of the people watching this show probably are wanderers. The number all the way back in 1981 was 65 million. It seems very likely that the number now could be well in excess of 300 million or more.

Corey: More.

David: So the 300,000 might be people who are not wanderers, who are the entrenched souls that have been recycled through planet after planet. They can't get the ascension. They keep screwing up.

Only 300,000 of them at the moment were actually ready to go.

Corey: That's exactly right.

David: Okay.

Corey: Yes.

David: And a majority of the children that are now incarnating are already from a higher vibration.

Corey: Yes. The children have agreed to some sort of contract to come here and assist us in this transition by, a lot of the time, just by being here and being loving and being good and kind.

David: Let me ask you this. A lot of times when we are dealing with really lofty metaphysics and so forth, I used to go to this place called the Fellowship of the Inner Light. It was an interfaith church in Virginia Beach.

The best speakers always got rid of all the complexity and said that the core of the spiritual path is learning to love yourself.

Do you think that if a person has very consistently non-loving thoughts about themselves, that even if they're being Service-to . . . if they're trying to be Service-to-Others of other people, but they're not loving themselves, that that could knock down their polarity?

Corey: Very much so. If we don't go through a process of forgiving others and forgiving ourselves, then we're going to hit one of those glass ceilings when it comes to becoming service to others.

When you're making changes and healing yourself, you're making changes to the super consciousness, a being that we're all a part of.

So when you're assisting yourself, loving yourself, you're assisting in loving the rest of humanity as well.

David: So let's go forward now, and . . .

Corey: Yes.

David: What happens?

Corey: And then for a few moments we went into some more personal things. I was wanting to know what percentage Service-to-Others I was. I was very disappointed at the response. And then I was asking about people around me and asking more about what we have to do to become worthy of the 300,000 or make that number grow.

And it came back to him saying that there were all . . . we all were holding on to too many third-density issues, and that once we learn to let those go, then it's going to be much easier for this energetic change to have a positive effect on us.

We are all being forced to look in these dark corners of our soul and at these different incidents in our life that we have assigned so much power to. People, if they've been abused by certain people when they were a child, they may be 40 years old now, but if they have not forgiven that person and dealt with that energy, that person has the same power over them now than they did when they were abusing them.

So once we start to turn it around and start focusing on ourselves and the negative things that we need to focus on, we'll be able to guide ourselves onto this optimal temporal reality that Tear Eir was communicating about.

David: What is this optimal temporal reality?

Corey: It is the best case scenario for our collective consciousness. It is the Ascension.

David: Okay. So what's the next significant thing that happens in this meeting?

Corey: Well, apparently there was also some confusion on the Mandela Effect. And he went into the Mandela Effect a little bit more and described about how it is a cosmic phenomenon. It's not just something that's happening down here on Earth, and that it is on such a cosmic level that changes are occurring in the cosmos and in our own reality.

There are things that have been edited, large events that have been edited out of our shared reality that we have no memory of now. So let's say all of a sudden, tomorrow there is some sort of a shift, and none of us have a memory of 9/11.

It seems like what he was communicating, very significant things like that had been re-edited in our past. And when he was describing this to me, I saw a giant wall of crystal rods that were spinning, rotating. And in the prism effect, things were just instantaneously changing like I was seeing weird things like cars changed colors and the way they looked, trees not . . . I mean it was like a . . . It was very weird and very hard to comprehend.

But he wanted me to know that this is a very big part of the shift that we're going through.

David: So are you saying that some of these events might be majorly catastrophic like the start of a World War III or the detonation of a nuclear dirty bomb or those types of very . . . or a huge earthquake that kills millions of people? That kind of stuff?

Corey: Yes. Yes, that kind of stuff.

David: And they're being edited out?

Corey: Right. And . . .

David: Is this being done by the Sphere Beings?

Corey: That was MY question. I said, "What is the purpose for you doing this?"

And his reply was that they're not doing it. We are. That all of the beings in a cert . . . all beings in a certain, I guess, sector, their co-creative consciousness is creating this Mandela Effect.

David: Hm.

Corey: Yeah. And I've had a problem wrapping my mind around that.

David: It is very interesting if you look at the charts of Mars, the planet, in the immediate four days before 9/11, the entire planet is engulfed with red smoke, red clouds. And it's an unprecedented planet-wide dust storm that we've never seen before.

Since Mars is the planet of war, it suggested that the collective trauma that WE experienced on Earth somehow was reflecting backwards in time, and Mars, being the history of wars like 9/11, actually was showing a visible representation of that.

So if time does work in this non-linear fashion, and 9/11 could cast its shadow back into the past like that, are you saying that events that will happen are casting a shadow back into our subconscious, and then we choose not to have it take place somehow?

Corey: That is probably better than I could explain it.

David: Okay. How do we alter the timeline?

Corey: I am not exactly sure how it's working. Our co-creative consciousness is changing our reality. And part of the problem is we cannot fully understand this effect in our current state.

Once we go through this shift, and we have the benefit of not having these third-density issues, our minds are going to see things from a totally different perspective, and different types of physics and cosmology ideas are going to make sense to us.

Right now, I personally just can't wrap my mind around how . . . I mean, I was surprised how important our co-creative consciousness is in this process. So I'm still wrapping my mind around a lot of this.

David: Could it be as extreme as us shifting into a reality in which there was no Cabal?

Corey: Yes. We could, all of a sudden, be in a reality to where we're post-Disclosure. We have no really recollection of sitting here pining for Disclosure. We're in it. And it could happen in a twinkling of an eye, and we would have no reference.

See what I mean, it's hard for us to wrap our minds around this?

David: Well, if I may quote the Bible, in the book of Peter, it says, "The former world shall not be remembered nor even come into mind once this new Heaven and new Earth comes in."

I've always been boggled by that Bible quote.

Corey: Another thing that will twist your noodle is Tear Eir communicated that many of the non-terrestrial beings that we're interacting with right now haven't even discovered our planet yet.

David: I don't understand that.

Corey: Exactly.

David: Ha, ha, ha. Many of the ETs that we're interacting with now haven't discovered our planet?

Corey: Yes. Let's say in 2080, non-terrestrials come into our solar system and discover us. These beings travel in time and space. There's no difference between the two.

So they come to a solar system, find it in its current state, and then go back in time in the solar system and start manipulating it.

David: Wow!

Corey: I'm still trying to wrap my head around that one too.

David: This also reminds me of Henry Deacon, who originally contacted me because he was so impressed by my inner planetary climate change paper I wrote with Richard Hoagland documenting NASA evidence of all the planets in the solar system changing.

And he said that they knew there was going to be a solar flash in his space program he was working in, which apparently was Solar Warden, although he disputes that.

And he said that as we get closer and closer to the solar flash, we'd be altering timelines so much that we could become so disoriented that we couldn't even have a coherent conversation - that there's a disorientation factor, because we keep hopping around on timelines.

Corey: Interesting.

David: Is that, perhaps . . . Could people be getting more and more confused as this goes on, because these timeline shifts appear to be very large?

Corey: Yeah, there's going to be a lot of confusion, because people don't know what's happening. Even you and I, we're discussing it, and we have a little bit of inside information, but we can't fully understand it.

David: I guess one of the things people would have trouble with is, well, wait a minute. If the reality that we're in changes, then wouldn't our written history books still have the old reality in it? Or is it that it changes in non-linear time, so even the history, the written history has changed in the books?

Corey: Well, we're sitting here going back and forth trying to understand something that we just don't have the ability to understand yet. Time and space, space-time – we don't understand it like we think we do.

David: Would you say that maybe after the veil drops, and we get into a post-Ascension world, that we would then be aware of the fact that we have been on one timeline, that it was successfully shifted at that point?

Corey: I don't know. I have no way of knowing.

David: Okay. So this whole weird Internet speculation about the Mandela Effect, they [Blue Avians] are, again, saying that it's true, but it's even bigger than we think.

Corey: It's going on on a cosmic level.

David: So this discussion of the Mandela Effect, can we alter it with our own intention? Can we collectively intend to have these shifts take place, a small number of us maybe shift the whole outcome?

Corey: Absolutely. And Tear Eir made it very clear that a very small number of people can act as a rudder for the rest of our collective consciousness, because everyone else is in such disarray that the people like in this community, and some others that are awakening and coming together, they have more power in their co-creative abilities than they know.

And when two, three, four people start getting together and focusing on a positive intent, then we are creating that positive future.

David: Well, and if your guys are talking like The Law of One, and they've told you to read The Law of One, it seems that they are the source of The Law of One. Would you agree with that?

Corey: Yes.

David: We've established that now? They are the source of The Law of One?

Corey: It took me awhile to get there, but yes.

David: The Law of One endorsed Edgar Cayce's readings as authentic, and that's in there. Anybody can read that. And Cayce had a group called the Glad Helpers during World War II. In a reading, he said

that that room of people, 40 people, could change and end World War II.

And they really didn't get it. They didn't get that 40 of them could actually stop Hitler and stop World War II from happening.

Corey: That's because these negative groups have been successful in keeping us ignorant of our co-creative power.

David: Did they talk to you at all about this co-creative power in this meeting after the Mandela Effect portion?

Corey: After the Mandela Effect, we moved over to discussing consciousness and how those of us in this community . . . it is perfectly fine for us to focus on the Secret Space Program and non-terrestrials interacting with us.

Tear Eir communicated that those of us in this field working on consciousness and ufology, we should begin to focus more on planting seeds and having a positive effect on our group consciousness.

And I wasn't given any specific ways to do that, because we all have our different talents or our different reaches or abilities, and every single person is just as important in this endeavor.

The person sitting home right now watching this show, they have interaction with many people in their life. And if they can have an effect on the co-creative consciousness of one, two, three people in their lives, that's a major effect that they're having overall.

David: So I feel like what you're giving us here is really valuable, because we are actually able to turn the needle and point the needle in the direction that we want it to go.

We are not simply watching this show and hoping that we're going to get Disclosure from the powers that were. But we control the outcome far more than we realize.

Corey: Absolutely.

David: And that is a very empowering message. **Corey,** I want to thank you for being here. And I want to thank you for watching. And anything you can do to try to live a more peaceful, stress-free life, we

have lots of great resources on this channel for health, wellness, fitness, and all that stuff is available to you as a subscriber.

So I encourage you to check all that stuff out. I'm [David Wilcock](#). This is [Cosmic Disclosure](#), and we'll see you here next time.

Cosmic Discosure: The Banished, From Inner Earth

Season 6, Episode 11

David Wilcock: All right, welcome to “[Cosmic Disclosure](#)”. I'm your host, [David Wilcock](#). I'm here with **Corey Goode**. And when we were talking through these updates last time, it was getting very, very interesting.

So without further ado, **Corey**, welcome back.

Corey Goode: Thank you.

David: So the gist of this message appears to be that a small number of us – and we have a really good number watching this show, a lot more than what was able to create the 72% reduction in terrorism in the meditation effect – that we could actually shape the whole future of humanity.

So we might have a lot more power in this thing than we realize.

Corey: Absolutely.

David: So that message takes away this idea that we're just spectators.

Corey: No, we're co-creators. We have the power to co-create. So use that power.

David: What's the next thing that happened after you were given this message about collective consciousness?

Corey: Well, I had a series of meetings with Ka-Aree, and they were in, I guess, what you've called The Construct.

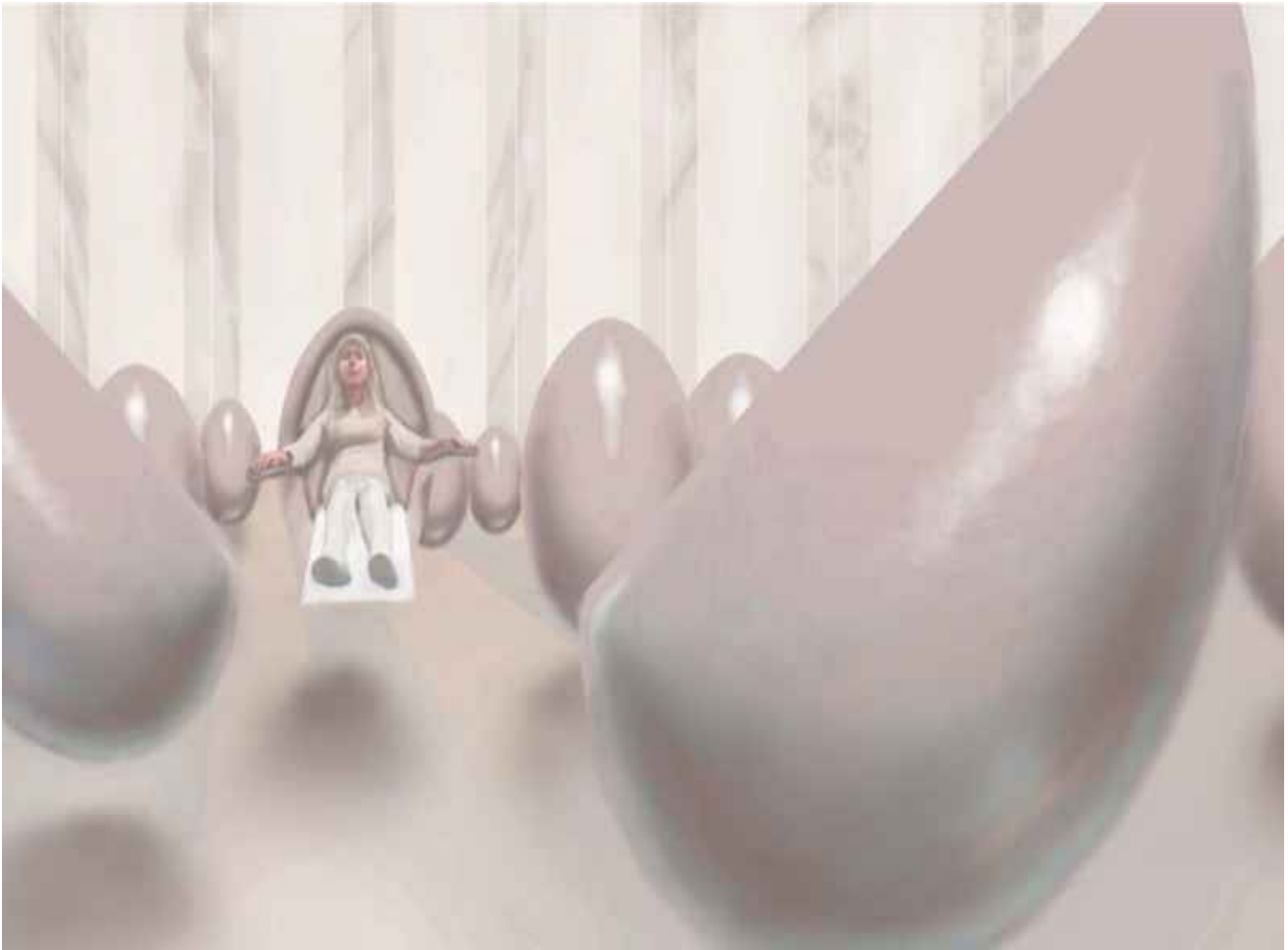

David: Okay.

Corey: And in one of those meetings, I described to her an encounter I had in Long Beach, California, while I was on vacation with my family.

We were all staying in a hotel room, and I woke up. And up in front of me was a woman, looking right down at me.

And when she saw me, saw my eyes open, she reached over and, with her hand cupped my . . . over one eye, and tapped me on the forehead with a finger. And I went back to sleep. I passed out.

David: And I remember, on a personal level as your friend, when this happened, you didn't tell me about this right away. And this REALLY, REALLY messed you up.

Corey: Yeah.

David: It almost ruined our friendship for a while because you were so traumatized by it. You didn't want to talk to anybody. This really messed you up.

Corey: Yeah, I mean, I was in there with my family, and I was caught off guard, and, also, I felt violated.

David: What did this woman look like exactly?

Corey: She was about my height or a little bit taller, from what I could tell, and she had blue eyes, blonde hair and looked very human.

David: Okay.

Corey: I woke up, and her head was above my head. And when I woke up, she seemed surprised, and then she reached over and touched my forehead, and then that's all I remember.

David: But you were aware of your family. You were able to see that your family was all asleep as this happened?

Corey: I knew they were in the room, yes.

David: Yeah.

Corey: So I shared this with Ka-Aree, and I had noticed in previous meetings that she had been kind of acting a little differently towards me, just like she was observing me.

And when I told her about this incident, she told me that it was one of the Banished that she had told me about previously.

She had told me that I was more than likely going to start encountering people that they call the Banished. And these are Inner Earth groups from all of the Inner Earth groups that over time had interacted with humanity in a way that was not according to their culture or beliefs, I guess.

So they were banished to the surface.

David: I'm not sure I understand what you mean by interacting with humanity in a way that was not in line with their beliefs. Whose beliefs?

Corey: With the beliefs of whatever group they were a part of. If it was an Anshar, and they were going out to the surface of the Earth or reaching out and manipulating, or trying to, I guess, interact with humans on a way that . . . in a way that they had signed treaties against, or in a way that they just didn't culturally accept.

It was breaking like a cultural law.

David: So would you say that these people were taking actions that most of the Anshar or other groups would see as being negatively oriented and not necessarily the most positive steps?

Corey: I don't know if they would put it that way. It would just be . . . against . . .

David: Or they're trying to push the envelope somehow.

Corey: Yeah, they're just doing . . .

David: Breaking the rules.

Corey: They're breaking the rules. They're breaking the rules. There are treaties between groups. There are all kinds of rules, and some of these people were breaking them.

David: So some of these Banished might actually be trying to speed things up, but in the process, they're breaking codes that might have been established by higher intelligence for a very good reason.

Corey: And after they were banished, these people began seeking positions of power in human culture. They started blending in with us as much as they could, living in small little enclaves here and there, having children with regular surface humans.

David: Really?

Corey: Yeah.

David: How long has this been going on for? Is this all throughout human history?

Corey: Yes, for millennia is how it was put to me.

David: Well, I thought you've told us before that a typical Inner Earth human is going to have some slightly different physiological features, like eyes that look a little larger, that kind of thing.

Corey: Yeah, but . . .

David: How could they blend in with people on Earth?

Corey: If you were not into ufology and you saw a very beautiful blonde walked up, and her eyes were 3% larger, you might think, “Wow! That’s a beautiful anomaly. I’m going to go talk to her.”

You know, you’re not necessarily going to say, “Wait a minute! She’s not from here!”

Well, after I had explained what had occurred to Ka-Aree, and she was visibly concerned, I was sent back . . . one of the communication ended as usual.

And I met with her a few more times. And we were talking about personal things, or she was giving me direction here and there. She was still watching me. I could tell she was observing me.

And then, all of a sudden, probably about six weeks after I told her, I’m laying in bed, white flash. I’m now laying on the floor in this big domed Anshar room that I had first arrived in when I met her the first time in the temple complex. I

David: So this is not The Construct now.

Corey: No.

David: This is you actually being portalled there.

Corey: Right.

David: Okay.

Corey: All of a sudden I’m laying on a hard, cold floor. And I sit up, and Ka-Aree’s walking in through the door that led back to the cleansing ceremony area where the pool of water was, the fountain.

And there were no guards this time. It was just her. And she led me back into the same area before, and I did that embarrassing cleansing ceremony.

This time only she was present and I was doing the ceremony myself.

David: So just to be clear, you have to strip down naked?

Corey: Yes, and cleanse yourself with the water from the pool.

David: And she's just standing there while you get naked and in her culture, it's no big deal.

Corey: Yeah. It's . . . Our getting embarrassed and stuff is just silly to them.

David: Right.

Corey: So after that, she headed out the door to what I'm calling the cleansing room, into that little hallway, and then she took a right to head back towards that domed room, and I followed her.

David: Were you in one of those robes like you had at the . . .

Corey: Yes.

David: Okay.

Corey: Yes, you have to put on one of those robes afterwards.

David: Okay.

Corey: And we went in and then took a hard right and walked . . . The domed room has a door on four sides. And on this side, was when we went into the cleansing room, we came out, took a hard right and walked in the doorway or hallway on the far side, one I hadn't been in before.

And we walked by doors that were covered by that hard light that I described before, kind of like a force field. And we walked to one door, and the force field turned off.

And I could see . . . it looked like a slab or a bed that had been formed. It was just even . . . There was . . . It didn't look like it had been manufactured and put there.

It looked like the whole room had just been carved around this slab. It was like molded up out of the floor.

David: Like it was extruded right up out of the ground.



Corey: Yeah. And she asked me to lay on the table. I have no explanation so far.

So I kind of sit on the table, first, and she walks across the room over to a wall where nothing was there, just like she did when she retrieved the nectar of Isis, what she tried to get me to drink the first time we were there.

And she turned around, and she had this big crystal rod, and it was phallic looking. It was very phallic looking, crystal.

David: So did you think . . . Ha, ha, ha.

Corey: I didn't know what was about to happen.

David: You see this thing. What do you think's going to happen?

Corey: I laid down on my back, and I was keeping an eye on her.

David: I could imagine.

Corey: And she came walking up, probably about two feet away from me. She was almost over me.

And she took it, and she started rubbing it on her hand like this [**Corey** motions with an up and down action on his palm, like creating friction], which didn't make me any . . . you know, ha, ha ha.

David: That's even worse. Ha, ha, ha.

Corey: Ha, ha. It starts singing. It starts making a noise, kind of like, you know when you rub your fingers on a glass with water in it and it makes that . . . you get tones?

David: Ah.

Corey: It was making sounds like that. And she just held it over my body and started waving it back and forth and then stopping here and there.

She stopped over my groin, my chest and my head, and she kept being drawn back here.

And it was making . . . almost like it was a metal detector when it was [buzzing], finding things. And she rubbed . . .

David: Did you feel the sound as well as hear it?

Corey: No, I heard it.

David: Okay.

Corey: I didn't feel it like in my teeth or anything like that, . . .

David: Okay.

Corey: . . . because I've had that sensation before. But she held it over me, and then she paused, and then it started making a real high pitched noise.



And I started seeing outlines or a head, shoulders, just – shoosh, shoosh – and there were like six of them that came out of my groin, chest and what appeared to be my head.

And I was EXTREMELY upset.

David: Did they just sort of look like amorphous ghostly forms, or did they have any shape or structure?

Corey: Yeah, they had . . . It looked like almost like a bald guy's head, and then shoulders, and then it just kind of blended down into shadow. It was kind of a see-through shadow.

David: Did it look like a regular human being . . .

Corey: No.

David: . . . or could you tell what the facial features were?

Corey: That's all I could tell.

David: Okay. Wow!

Corey: And it was about half a dozen of them that left. And I got up on my elbows like this on the table and I was like, “How did this happen? What's going on?”

And she correlated it back to my meeting with one of the Banished when she had touched my head. She said that they had used a process to where they had infected me with entity attachments.

David: Wow!

Corey: And they did this as a way to gain intelligence on what was going on with the Anshar.

David: So while these beings are attached to you, they can read your thoughts and relay it back?

Corey: I don't know how that works. Or they just might report what they see or observe.

David: What did you feel as these beings left you? Did you have a consciousness change, a feeling of . . .

Corey: No, I had a feeling of fear, of shock and fear.

David: Hm. Okay.

Corey: So I was very curious to why about at least nine other meetings we had had, she had not told me, A, “You have an entity attachment,” and B, where it came from.

David: Hm.

Corey: And I was also very curious to know why she didn't remove it during that time period.

David: Sure.

Corey: Why would you . . . I mean, why would she leave it in me? You know, I was very . . . I was upset at the time, and I was wanting to know the answer to that question.

And she replied back with something that I really don't understand. She said that they had not yet

attached to my energy vortexes, that once they attached to my energy vortex, she is able to, I guess, exorcise them from my body, but also close whatever portal they would use to come back.

David: So it's almost like they have to set up shop and lay a foundation and kind of build a house.

Corey: Right.

David: And if they're on the go and they haven't really settled in yet, they can't be resonated out with this technology.

Corey: Yes. And she said that she didn't think it would be in my best interests, those weeks prior, to say, "You have an entity attachment. It's going to hang onto you for a little while. Don't worry. I'll take care of it in four or five weeks." Ha. So, she just didn't tell me.

David: Did you ask her how this was allowed to happen in the first place? I mean, you've been protected from death before. Why would they allow somebody to come in and stick entities in you?

Corey: I don't know. I've been told that there's a possibility that I could lose my life in this mission, so there are no guarantees. In every conflict, there are casualties. So stuff's going to happen.

David: Right.

Corey: Some negative things are going to happen. I guess one of the things . . . If you don't run into the Devil, you know you're probably walking the same direction they are.

David: Ha, ha.

Corey: You know, you're going to have these negative interactions.

David: So what's the next thing that happens in our story after this?

Corey: Well, directly after this, that's when we discussed the Banished a little bit more. We discussed . . . She told me about how they live in enclaves on our planet, and I think people . . . I think it's been out there that there have been different people that have reported that there are nonterrestrials living in groups here and there on our planet that our government knows about.

David: Yeah, I was briefed on that by Henry Deacon. I'm not going to say where, but I was given the specific name of a small town in which a large number of the people in that town, in America, are

actually extraterrestrials with, as I've told you privately, different number of teeth, doctors in the town that know how to take care of them.

They don't like crowds. They always stay alone. They can't handle the telepathic interference of being around large crowds.

So this Banished stuff kind of fits in with some things I'd heard before.

Corey: Yeah, it kind of makes me wonder if that's what some of these groups are.

David: Because he had told me that they were Atlantean, that they were basically people who backdated to Atlantis, . . .

Corey: There we go.

David: . . . but still had that same kind of energy from Atlantis.

Corey: There we go.

David: Yeah.

Corey: And that's when she also told me more about how the Banished had intermarried into families of power. They're seeking power.

David: Ah. So this like is Cabal related as well.

Corey: Absolutely. Yeah.

David: Wow!

Corey: Some of them are making alliances with and marrying into some of these families.

David: So if the Anshar . . . Some of the oldest ones have been here for millions of years, then do these Banished actually have longer lifespans as well?

Corey: No. Well, they have the same lifespan that Ka-Aree's people do.

David: Which would be what?

Corey: I mean, Ka-Aree was over 130 and still looked like she was, you know, in her early 20s.

David: Okay. So the Banished then, even though they live on the surface of the Earth now, they might have dramatically longer lifespans . . .

Corey: Right.

David: . . . than regular people would.

Corey: Right. And from what she said, that life extension did not genetically make it into the children that they had with people on the surface.

David: Okay, so the documents that you had leading up to our taping here, you had to write it all down. You had 8,000 words, and you told me that you now have to have this reviewed by a particular group, and that what came back had only 5,255 words. Thus, 35% of this work that you just did over the weekend, hard work to write up your experiences, 35% of it had to be removed.

So I guess what I'd like to know is, who are you working with that now wants to review your writing?

Is there something going on that's so timely and sensitive that they're worried about you spoiling operations that would otherwise take place? Let's just talk about that for a while now.

Corey: Sure. I had been actually complaining, as I do from time to time, to Gonzales about the lack of fresh intelligence I was getting. I hadn't been getting it for a while and for obvious reasons.

After I had been picked up by military-industrial complex Secret Space Program – we'll just call it MIC-SSP now – I had been put through a process where I accidentally gave up three people, including Gonzales.

David: Right. And those who watch the show will remember that you went through some sort of sedation. You were shown something like an iPad. Your retinas, or whatever, registered these faces, and you ended up outing these people, one of whom was Gonzales, which threw him into a whole different reality.

Corey: Absolutely, and absolutely angered the SSP Alliance. They were not going to give me any more information, any actionable intelligence, nothing.

David: And it appeared that Gonzales himself was very angry at you . . .

Corey: Oh, yeah, he was.

David: . . . sitting beside the Wrangler while you're there being interrogated.

Corey: Yeah.

David: Okay. So this MIC interaction caused them to become very angered by you, and the SSP Alliance felt that you had betrayed them somehow, even though I've always said, how could you have possibly prevented this?

Corey: Yeah, I couldn't have. And my question was, why didn't they come in and prevent it?

David: Right.

Corey: But, I digress.

David: So you said you were feeling like you weren't getting intel anymore.

Corey: Yeah, I was . . .

David: You got blacked out.

Corey: It was getting to a point to where a lot of the people I was working with around me were starting to withdraw and do their own things. I was feeling more and more isolated, and I felt like I needed to turn to Gonzales and say, "Listen, I want more intel. What do I have to do to get it?"

And the answer came back, before I release information, I have to send it through them for approval. But I had no idea they were going to be redacting 35% of what I was wanting to put out.

David: So how is this happening? Do you have some kind of contact person that you're sending these things to now, or . . . ?

Corey: Yes, I'm not going to go into it.

David: Okay. So in our private discussions, you've actually said that you're not even authorized to tell me what's going on, but you also said that if you could, that I would really like it.

So part of what appears to be going on - I don't know how much you can talk about this – is that even at the time of this taping, there may be some very sensitive operations getting ready to happen, that guys like me who've been doing this for so long are going to really like the outcome, but that it's so sensitive that we can't reveal it because it could screw up how it takes place.

Corey: That's correct.

David: It does appear that we're building up to some sort of major events.

Corey: Yes, several different events that they're working towards right now.

David: If you could give us just a little bit more of a clue of what they actually did authorize you to say about this, if there's anything, is this something that will make the people that watch this show happy? And what kind of happiness will they experience?

Corey: The part that I can share is not the part that's going to make people happy.

What I can share is that Gonzales reported that a lot of these secret Earth syndicates and the Earth Alliance were making a lot of progress in their negotiations. They had decided on a lot of things. They are just now working on the fine details.

So when it comes to the financial system and a lot of truth coming out, yes, I'm optimistic, after what I've heard.

David: What kind of financial changes do you think might take place?

Corey: It's going to be a switch over to the new financial system that we've heard so much about over the last five or eight years that has never come into fruition – that this is actually really going to happen.

But, you know, that's not necessarily a good thing. It's just a different system. But it is taking power away from the Cabal.

David: Okay. Are we going to be looking at something more like the Special Drawing Rights [the International Monetary Fund's form of international money], where the currencies of the world are

thrown into a basket and they're weighted based on, for example, their overall gross domestic product? Is that the kind of economy we're looking at?

Corey: Yes, but that's the part they're still negotiating, the fine details.

David: Okay.

Corey: A lot of groups don't want it to be an even playing field, currency wise. They want it based on some sort of a GDP, but that's still in negotiation.

David: Are you being told that at some point in the future, that you will be allowed to release these things that right now you cannot?

Corey: I'm not being told that in the future I can release it, no. I'm just being told that certain things I cannot talk about because there are operational projects going on right now.

And a lot of it, also, after that perceived betrayal by me in that situation where I was being interrogated, I think they're also really kind of testing me as well.

David: Do they believe you and your story?

Corey: What do you mean?

David: Do the MIC people think that you're telling the truth?

Corey: No. No. I had another meeting that I will share at some point with this group that had interrogated me before, and I was told that most of the people in their project think it's all a big joke.

David: Hm. So what you're saying is that there's some really juicy stuff here, that you've been told that for whatever unfortunate reason you can't share with us, but if we could hear it, we would be happy.

Corey: Yes, on a lot of it you would be. There's some stuff that's not all that exciting.

David: Okay.

Corey: But some of the next encounter I can talk more about.

David: Okay, so what was the next encounter after where we were in the story here?

Corey: The next encounter was when my wife and I, we went to Sedona for a vegan – not really, . . . I guess, a raw non-cooking kind of experience to learn how to be a proper vegan.

And while I was there, a Blue Sphere came into our hotel room. That's unusual. I don't normally have Blue Spheres come and pick me up when I'm traveling. It just doesn't normally happen.

I got up, indicated I was ready for transport, and it took me up to, once again, a Blue Sphere. And on that Blue Sphere was Tear-Eir and Gonzales.



And, of course, I looked up at the cosmic scene, and it looked basically the same as before. I could still see . . . There were about nine metallic spheres.

And the scene looked pretty close to the same, with the buffeting of energy across the Blue Spheres having that watery effect.

David: Uh huh.

Corey: It looked pretty close to the same. So I turned my attention back to Gonzales and Tear-Eir, and they were right in front of me now.

Tear-Eir communicated something that I thought was kind of low on the totem pole information wise for him to be addressing me about.

And it had to do with all of these new so-called SSP whistleblowers, . . .

David: Right.

Corey: . . . and that some in particular were trying to rewrite the Blue Avian message and origins to match their belief systems. And there was . . . And it was causing a lot of confusion.

So I thought that was kind of odd, because that's not normally the kind of thing that sixth-density beings want to communicate with me about, but I guess it was important enough that it needed to be addressed.

So Tear-Eir told me that some of these situations I need to address in as loving a way as possible.

David: Well, let me ask you this. Are there any other SSP whistleblowers who are out there representing themselves as such right now who you actually think are disclosing the truth?

Corey: Yes, there are some SSP whistleblowers out there that have good information and appear to be telling the truth. There are a whole lot of other ones that are, I guess, trying to live a mythical life or write themselves into the narrative.

But that's what Tear-Eir had concentrated on, speaking about that. And then he went on to give me some advice about how to handle it, how not to interject emotion into it and all these kinds of things.

And that was the conversation. Some personal things were pointed out to me as well. I was given guidance about my attitude and certain things that I needed to change.

David: Okay.

Corey: And then I have the conversation with Gonzales. And Gonzales tells me, “Listen, the negotiations have gotten to a point to where the Powers That Still Are, are about to release and disclose, fully, the military-industrial complex's Secret Space Program,” which consists of oval-shaped craft, triangle-shaped craft that fly in and out of our atmosphere, going into lower Earth orbit to service a couple of space stations that are owned by the DIA, NSA and the Air Force intelligence groups.

David: What would these space stations look like if they're announced?

Corey: Pretty much like what we've seen in sci-fi, round, kind of donut looking. They're not super sophisticated, probably maybe 20 to 50 years more sophisticated than the International Space Station.

And he stated in order for them to be successful in disclosing this information, they need to quash and quiet – that means discredit – anyone that is giving legitimate Secret Space Program information, because when they release this as being THE TRUTH, they don't want people saying, “Hey, what about bases on Mars? What about this? What about that that **Corey** and **Tompkins** or any number of other people have talked about?”

They want to be able to say, “Oh, you mean the person that was discredited?” and that way discredit the information as well.

David: Do you think that's going to be successful?

Corey: I don't know. I don't know. They're already working. They're marshaling their forces right now. They're getting people that work in the field, in this field, to, I guess, get on board with this, I guess, appeal to their egos and give them a briefing and say, “This is information that's . . . You're getting the top of the totem pole information,” so the people succumb to their egos like a lot of the people in the military-industrial complex have, that believe that they've been given the highest intel in the land.

And he stated that what was under way was that these various intelligence groups were trying to super soldier the SSP topic.

What happened was that the people that were telling legitimate stories suddenly became drowned out by all of the groups of people coming in and saying, “I'm a super soldier.” “I'm a super soldier.”

And then it became kind of a big community of people just sharing their super-soldier stories.

David: Right. And I remember reading something online of a guy saying he could jump out of a helicopter, and he could land in such a way that his legs were really springy and he could bounce up and he didn't need a parachute.

Corey: Yeah. That's not how it works. Yeah.

David: Silly stuff.

Corey: Yeah, silly stuff. But it's become this whole thing. And now, if you were to mention the super soldier projects to any number of researchers, they're going to scoff at it now. You know, "Oh, all that's just debunked. It's a bunch of BS, da, da, dah."

David: Right.

Corey: So that was a very successful operation. So he said, "I can see in the future there being conventions where people show up and say they were in the Secret Space Program, and they all sit around and tell their stories, and that they're not doing it to be malicious."

There's also the aspect of people that are being manipulated into thinking that they were in the Secret Space Program.

David: Well, I want to point out that you said this to me before this guy Max Spiers, who claims to be a super soldier, suddenly announced that he was dead. And it becomes a top story on "Drudge Report" and a top story on "Daily Mail". He vomits black goo, and then he's dead.

Corey: Right.

David: You had told me that before that happened.

Corey: Right. Yes, so we're starting to see the beginning of what's going to be a major campaign to discredit anyone talking about this topic.

So he communicated that with me, and he said that I should get together with people in this community and find a way to mitigate that problem as much as possible, to prevent it from growing into that kind

of a community and causing those kinds of issues.

So it was a big enough deal that I had a quick meeting with Tear-Eir and Gonzales about, and Gonzales was concerned. So that was the end of that meeting, and since then, just as you've mentioned, we've seen several signs that that indeed is occurring.

David: Right. So what would you feel is a way to preserve the credibility of what we're doing with this show and what we've done with **Tompkins**, things like that? I mean, I know, **Tompkins**, we didn't even know about him until after we'd already taped 40 to 50 episodes of this show.

Corey: Yeah.

David: And then it's like, "Oh, my god, here's this guy who knows all the same stuff."

Corey: Right. Well, then, and they're also doing this project as a way to discourage future whistleblowers from coming out. If they totally humiliate me or **Tompkins** or any of the others, then I think they believe that future whistleblowers will just stay quiet.

David: Right. How would you like to be able to let us know who is real and who is false as this goes forward? Do you have any idea of how this is going to happen?

Corey: Well, that's going to have to go with each of the viewers and the people out there. They're going to have to start using more discernment . . .

David: Okay.

Corey: . . . and not start getting emotionally attached to a story just because it's exciting and they like it.

David: Right.

Corey: So they're going to have to vet themselves.

The last thing that Gonzales and Tear-Eir want us to do is to get into a position of, "They're a fake. They're real. They're a fake," and then all this inner fighting starts to occur in our field.

David: Sure. Would you say that if you never mentioned anyone as credible, that that means that they're probably not?

Corey: It could be.

David: Ha, ha. Fair enough. All right. Well, that's all the time we have for in this episode. I'm your host, [David Wilcock](#), here with **Corey Goode**. And we will see you back here next time. Thanks for watching.

Cosmic Disclosure: Troubling Encounters

Season 6, Episode 12

David Wilcock: All right, welcome back to “[Cosmic Disclosure](#)”. I'm your host, [David Wilcock](#). I'm here with **Corey Goode**, our insider's insider. And in this episode, we are continuing our fascinating investigation into the updates that he has been experiencing as this whole narrative moves forward, and all of the intrigue and the interesting things that are going on.

So without further ado, **Corey**, welcome back to the show.

Corey Goode: Thank you.

David: So where we last left you, we were talking about how you are now getting intel that is interesting to you, but that it's going through a review process.

And that seems similar to the job that you were offered before that you turned down when we discussed this in previous update episodes, where you were going to kind of fulfill the role that Gonzales was filling, because they had nobody else who could do it, but then you turned them down.

Now it seems like, in a sense, you have something like that, where you're getting some intel. You have to maintain some confidentiality. You can't tell me or anyone else.

Do you feel like that's the same thing, or do you feel like those things are different? What you're doing now is different than what they offered before.

Corey: It's much different.

David: Okay.

Corey: What I would have done with them before would involve me not doing TV shows.

David: Not at all?

Corey: Right. It would have involved me basically disappearing into the background and taking over doing what Gonzales was doing when he was here.

David: Would you have had to say that everything you said was a lie and discredit yourself, or would you just disappear?

Corey: Just sort of disappear.

David: Wow!

Corey: Yeah. So, yeah, things definitely . . . and in this topic have escalated since then. There are three incidents I'd like to talk about today, and we can . . . and a couple of them were pretty quick, so we can cover them fairly quickly.

I had a number of encounters over the last couple of months, and the number of pickups I've had to go to the Blue Sphere has increased.

David: Hm.

Corey: And there's obviously something, something . . . It's picked up. Something is going on.

David: There was a period of time where you really weren't getting that at all . . .

Corey: Right.

David: . . . and it had kind of just become you and Ka-Aree and The Construct for the most part with Gonzales.

Corey: Right. And I was literally withdrawing from not having fresh intelligence. It was . . .

David: Right. You were starting to lose your inspiration.

Corey: I was.

David: Yeah.

Corey: Well, not anymore. There . . . A . . . Some of these almost blend together because I wasn't documenting them as soon as they happened because I had other things going on.

David: You were doing some of your own events for the first time. Those events were deemed very successful. I've heard really positive feedback about you at Mt. Shasta, for example, those kinds of things.

Corey: Right. But the meetings kind of have changed a little bit. They've been more frequent, and in some cases rushed, like the one I'm about to tell you about.

David: Okay.

Corey: I was at home, and I got picked up in the normal way with a Blue Sphere. And the Sphere took me up, or the Blue Orb took me up, to a giant Blue Sphere again.

And immediately I noticed Tear-Eir and Gonzales and Mica together, and they were real close to me this time.

David: Hm.



Corey: And I was looking at Mica, because I like to look at him. He's just so . . . He's just beautiful as a being – his energy.

And Gonzales stepped forward and grabbed my hand, and just did one . . . a one pump shake like that.

And I noticed Mica was watching us very closely. And then Gonzales went on to talk a little bit about what had been occurring in recent meetings, that they were getting further and further along on this new financial system, that the transition they were hoping to be smooth, but more than likely would be rocky, and that I should put some money into some precious metals, and that I should definitely make sure that I have enough food on hand for me and my loved ones for a period of time.

David: Okay. What do you mean by rocky?

Corey: Not a smooth transition. There could be a complete drop in commerce for a period of time to where, you know, kind of similar . . . if there's a hurricane, all the food gets wiped out in six hours and then there are no new trucks coming in. You know, that kind of a situation.

David: We've heard about this financial change before, and some of the things you've leaked in the past indicated that they kind of want to just change it over without really telling us anything, but what you're describing now sounds like there would be some kind of an announcement.

Corey: Yes.

David: This would not just be a covert operation.

Corey: No, it won't be covert, and there will be some disruption, according to what Gonzales was saying.

David: Okay.

Corey: So we covered that a little bit, and then we went back on to the topic of the false SSP whistleblowers, and the program that they're getting more and more intelligence on that is about to be executed against people who were involved with the SSP program to discredit us.

And there were some more details about that that I'd like to keep to myself for now. And then he very quickly and abruptly ended the conversation, reached over, gave me a shake again, and he doesn't

normally shake my hand.

And he walked back and stood next to Mica.

And I'd been glancing over at Mica throughout the short conversation, and he was observing us very closely.

Mica walks up to me, sticks his hand out, so I stick my hand out, and he does a one pump shake. And he looked very pleased with himself that he was partaking in our culture in some way.

David: Ha, ha.

Corey: And he said, "Let's walk and talk," and he slid his arm inside of my arm like you do it you're walking along with usually a person of the opposite sex. And I guess I was as little uncomfortable by it, and he noticed within two or three steps, and then he pulled his arm out and put it to his side. And then we kind of walked a big circle talking and then came back to where Gonzales was.

But while we were doing a short little walk and talk, he started telling me that his people are beginning to reach out to our people in their dream state to introduce themselves and to impart information, to give us teachings on how to extricate ourselves from this current control system of the Draco, which they successfully did, how to come together as a society when our society has been programmed to inter-fight.

So his people are beginning to lay the groundwork for open contact and assistance from them in the future.

It was, again, a very rushed conversation as we were walking and talking, and I had some questions I wanted to ask him, and it was along the lines of how his people are going to interact with ours.

He mentioned a few brief things about how his society struggled to go through the transition that they needed to to become what they were today.

David: Hm.

Corey: And he was just letting me know that it is not a smooth transition, and that his people are going to be here to help us through it.

David: Right. That's very cool.

Corey: The only thing that I really got out of it that was really new was the information about his people starting to reach out to ours, which is exciting.

So Mica walked right up to Gonzales, and I was about to ask him a couple questions. And, as a matter of fact, in the beginning, I told him I had a couple of questions.

He asked if I was able to process the information that he'd given me last time, and I told him, "Yes. I had spent a lot of time thinking about it, and I had a few questions."

And he said, "There will always be time for questions."

And then at the end, I thought I was going to get to ask one of those questions, but instead he just walked me up to Gonzales, and he stood next to Gonzales and turned towards me, and a Blue Sphere appeared behind him and Gonzales and shot out immediately to me.

David: Hm.

Corey: It was time to go, so I went home and that was the end of that encounter.

It was very soon after this though that I was picked up again by this military-industrial complex Secret Space Program that had interrogated me months before.

David: Okay. So when the MIC picked you up this time, did it have any difference in quality to some of the other ones, because some of the ones you reported in these previous updates sounded pretty hostile, pretty unpleasant?

Corey: Well, this was a little more cordial, a little bit more. All of a sudden, I was awake after going to bed. I was awake, and I'm walking down my alley barefoot in my shorts and t-shirt that I sleep in.

David: Oh, my gosh.

Corey: And as I'm rounding around a gate to this parking lot that's right next to my house, I see this huge craft using it as a landing pad, and there are two . . . looked like Air Force airmen standing outside.

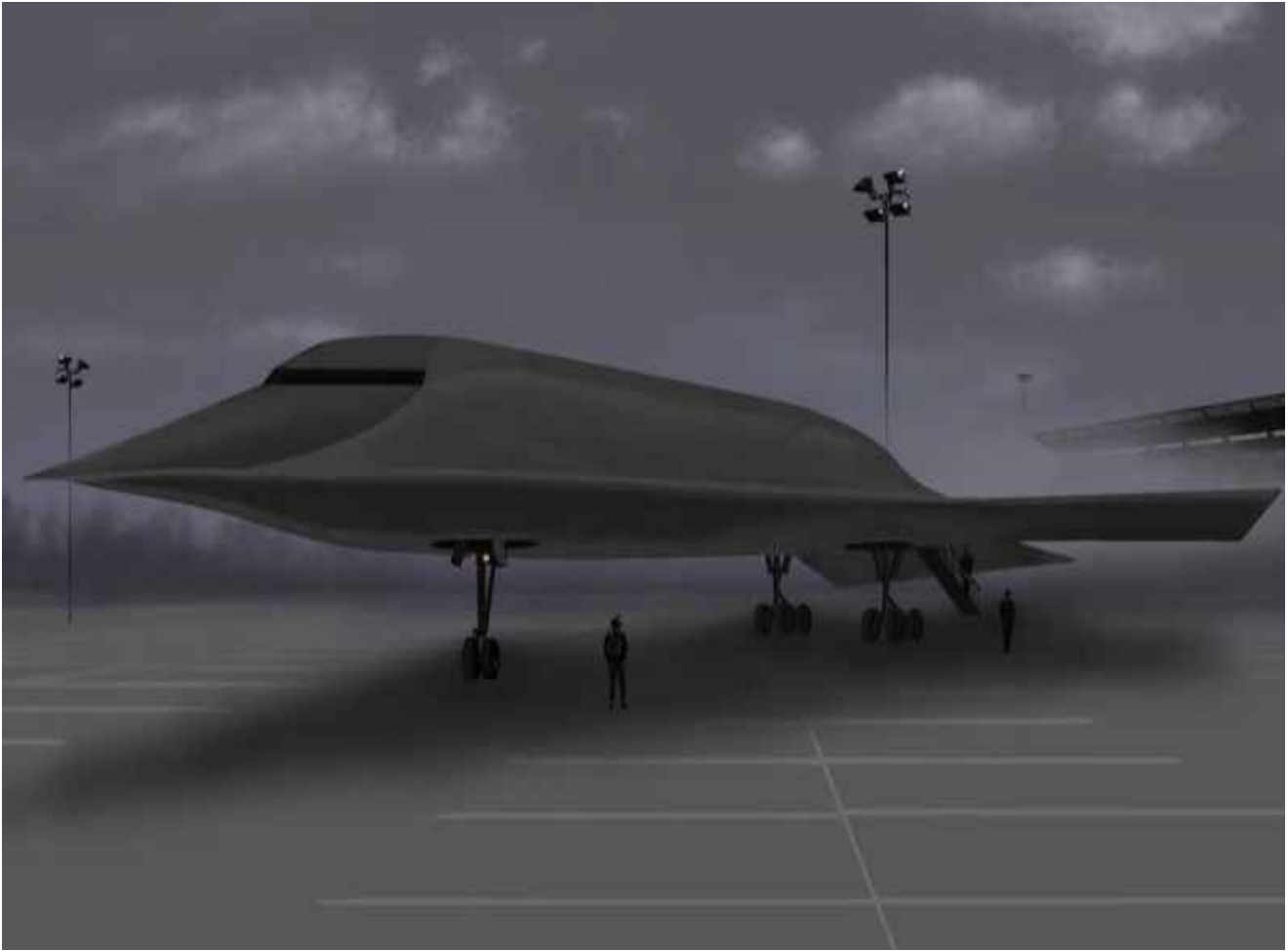

David: What do you mean by huge? How huge is huge?

Corey: It is probably about 100-feet long.

David: Wow!

Corey: It was big.

David: What did it look like?

Corey: It looked similar to some of the shuttlecraft that the SSP had transported me on, including the Mars Adventure that we reported on, configuration wise, but this was more of a stealth-looking craft.

It didn't have wings on the side. It was . . . If you looked at it from the top, as weird as it sounds, it was shaped sort of like a fish.

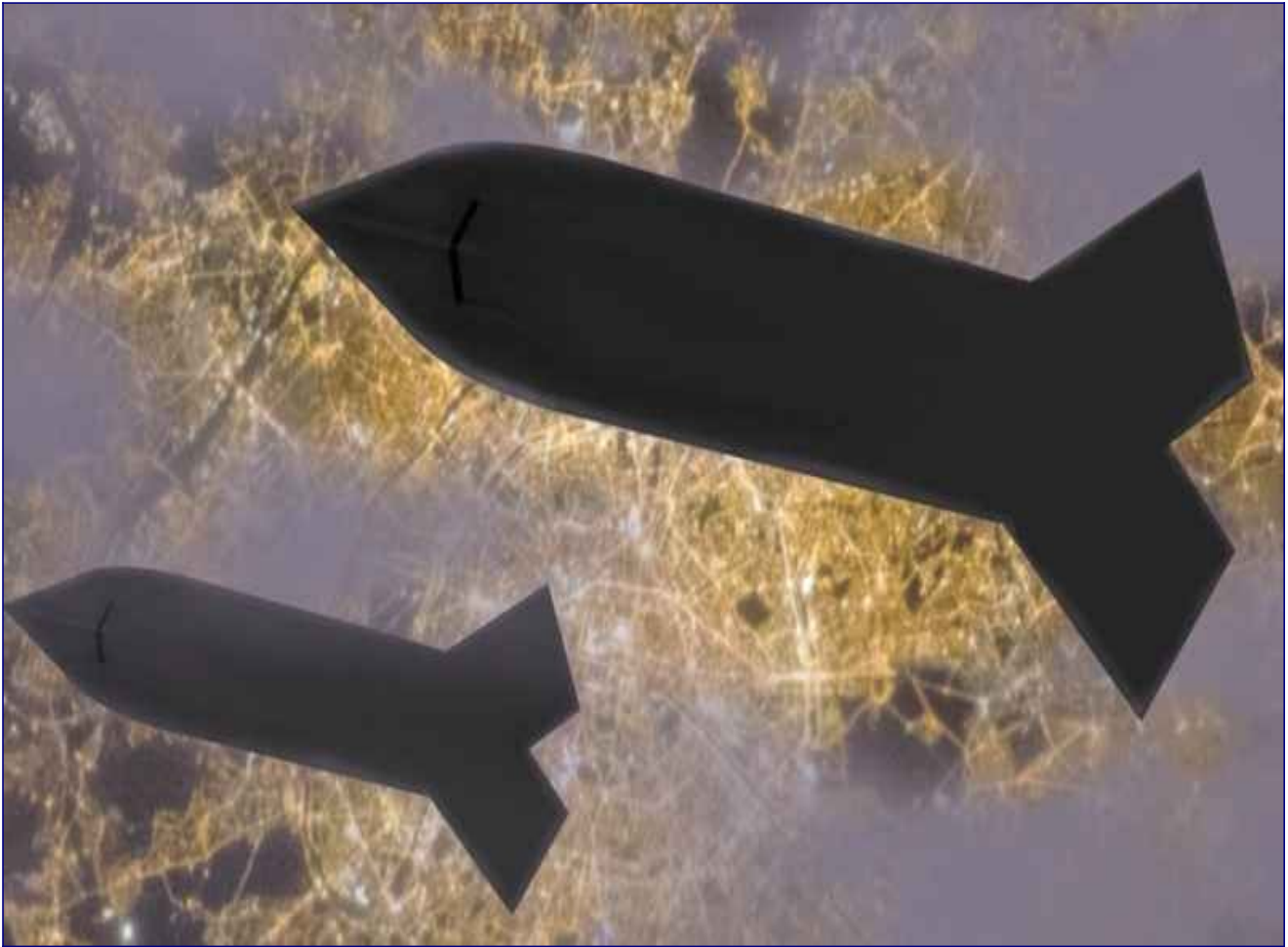

It's nose curved up. The fuselage was narrow all the way to the back, and then these two little fin-looking things came out. Looked like tails.

David: Hm.

Corey: Looked kind of like the tail section of a conventional craft without a stabilizer.

David: Okay.

Corey: And the ramp at the back was at the tail, opened down this way. [**Corey** points with a sharp angle downward.] It was a ramp with stairs on it, very narrow – enough for one person to go up.

David: Did it have landing gear, or did it hover?

Corey: No, it had landing gear just like a conventional craft.

David: Okay. And what was the surface appearance? What color . . . Whatever did it look like?

Corey: It looked like a stealth craft.

David: So black?

Corey: Grayish, almost black.

David: And they landed this 100 ft. craft in a parking lot or something?

Corey: Yes, in a residential area.

David: Wow!

Corey: Yeah. So the two airmen that were waiting for me walked me up this ramp - very narrow, VERY steep ramp.



So I walk up the ramp. I walk through a room that's mostly dark, but there are cargo nets on the ceiling and wall, and something's in the cargo nets. It's some sort of storage area.

And then we walk through a small other little area that looked like you might prepare food in it. It was just a real small area.

David: Okay.

Corey: And then we walked through the next door, and I found myself in the exact same room where I was before, where it had the three chairs on the wall and the two beds on the wall.

David: Oh, my goodness.

Corey: And my heart was beating really fast. I was . . . I was . . . I was worried.

David: That's the interrogation room.

Corey: Yes.

David: Yeah.

Corey: So the two airmen had me sit down in the same chair, and then they buckled me in . . .

David: Wow!

Corey: . . . strapped me in, and then left without saying a word. They didn't say a word at all in the beginning. And next thing I know, they . . .

David: But they also had somehow been able to control your mind, right, because you say you wake up sleep walking in your pajamas in the alley next to your house?

Corey: And not only that, after I woke up and was wondering what was going on, I was still automatically going where they wanted me to.

David: Really?

Corey: Yeah.

David: Your body was like on its own thing.

Corey: Mm-hmm.

David: Wow!

Corey: Yeah.

David: So now you're in a chair strapped in, just like last time. You must have been really freaking out by this point.

Corey: Right, and I did . . .

David: Because nobody talks to you.

Corey: Right. And I wasn't encouraged when they came out . . . The two airmen came out and had this cart, a rolling cart on the floor that they were messing with syringes and other things on.

David: Oh, my gosh.

Corey: So they were preparing to do some sort of an exam, and I could see what was going on. I could tell that they were about to perform an exam.

David: Like a chemical interrogation or something.

Corey: I didn't know what. And while I'm looking at them doing this, the door opens in the front closer to where the cockpit is, and in comes this older guy in an Air Force uniform as well, BDU-type uniform. [BDU: battle-dress uniform]

It looked like the day you buy them. It didn't have any of the flir or patches that you have on the shoulders or chest that indicate your name, rank . . .

David: Ah. Wow, that's weird.

Corey: . . . or where you're assigned. And he came in the room and they snapped to attention, so I could tell immediately that he was in charge.

David: And what did this guy look like? What was his basic facial features?

Corey: He looked like he was about 5' 10", 5' 9". He looked like he was in his late 50s, maybe early 60s. He had a white goatee and white short hair.

David: Okay.

Corey: Yes, and he carried himself very cocky, like he's in charge.

David: Wow! Okay.

Corey: So he sits down in the chair right next to me, I mean, right next to me, and begins asking me just questions about . . . again, like the Lunar Operation Command, about individuals that I had given up the last time, how I knew them. He was obviously skeptical.

He was telling me that, “You know that all the people I work with in all these programs are laughing at you and ridiculing you, right?”

And I said, “Yes, I've heard that.”

And he was addressing me by my first name, and I asked him, I said, “How should I address you?”

And he just gave me this look like I was an idiot, and he said, “You can address me as 'Sir'”.

I said, “Okay, sir.” I said, “What is going on?” I said, “I've been through this before. You got the information that you wanted from me, right?”

And he told me that he didn't believe it.

David: But didn't they have scientific validation that you'd been to these places by taking hair samples, and you had traces from those places in your hair?

Corey: Yes.

David: Okay.

Corey: And while we were having this conversation, the two airmen immediately walked over and repeated the process. They took blood, skin scrapings, swab in my cheek and took more hair.

David: Now before any of that happened, you say he sat down right next to you. Was there any threat? I mean, obviously that you're not going to do it, but is there any threat once you've been harnessed into

this chair that you could have gotten your hands on him or tried to attack him in some way?

Or were you harnessed in such a way that that wouldn't have been possible?

Corey: He was close enough to where I could've messed with him.

David: Okay.

Corey: Yeah.

David: So he's pretty brave then or trusting to get down next to you and not think that that might happen.

Corey: Yeah. Well, I was strapped down in a folding chair, clearly at a disadvantage.

David: Of course. Right.

Corey: Right.

David: There's no benefit to you doing that.

Corey: Right. I mean, they'd take me out and throw me into outer space if I did something like that.

David: Right.

Corey: And he said, "Yes," he said, "the men that did those tests were working under my orders, but I don't trust the results."

He said, "I am here to observe the tests being done again, . . . "

David: Oh, wow!

Corey: ". . . and to also maintain chain of custody on the evidence" that they gain. He's going to bring it to the lab himself, basically.

David: So he would obviously be part of that MIC program in which it's so compartmentalized that they're told they're the top, and they have no idea of this world that about six other people besides you have told me about – that's what we're calling the Secret Space Program. He just has no idea about it.

Corey: Yeah, that's definitely how it seemed, but he was being real coy. He was . . . He seemed like he was reading me. When he was asking me questions, I felt like it was a human lie detector test.

David: Hm.

Corey: You know, he was . . . He just had that air about him.

David: Okay.

Corey: So they had already taken the samples from me, and they had left the room, and then – 'they' being the two airmen -

David: Okay.

Corey: - and this other guy remained with me, they guy in charge. The two airmen come back in, and I see in their hand they have another one of those iPads that they'd showed me before.

David: Oh, boy.

Corey: And he said, "I would like you to look through these pictures and let me know if you see anyone that you recognize."

And I immediately closed my eyes. And when I had my eyes closed, I was sitting there because they held it up. I could see six photos of people – headshots. So I closed my eyes.

I was like, "No, I'm not going to do this again. I'm not going to do this again."

And I hear walking around, and then all of a sudden I hear this "bizzZH, bizzZH" sound, and I felt it all through my body, and I felt myself just going to . . . not to sleep, but just . . . I no longer had control of my body.

David: Wow!

Corey: It changed my state of consciousness somehow. And my eyes were open, and I was hanging down with my head down. And my head was basically looking at my lap – my face was.

And I saw the iPad slide under, and just . . .

David: This is very similar to what happened last time.

Corey: Yep.

David: Yeah.

Corey: Just like last time. They went through, and it was the same three individuals. It was no one new – Gonzales and the two others. I identified them again.

And then he stated that he thought that this SSP Alliance I was talking about were people from one of the groups he oversees that had broken away.

David: Hm.

Corey: Because, indeed, one of the people did belong to one of those groups that reported to him.

David: Hm.

Corey: And he was thinking that there was some craziness going on inside his rank.

David: Did you get the sense that he wanted us to know the truth, us as humanity, at some point, or did you get the sense that he wanted to keep this very secret?

Corey: My sense was that he was there to do a job, and his job was to find out if I was full of it or not . . .

David: Okay.

Corey: . . . by taking these trace samples that he had his men do. And he wanted . . . I guess, he was one of these “show me” kind of people. He wanted to see for himself.

David: Right.

Corey: So after I identified the people in the photos, they turned off the device, and I looked up, and he wasn't sitting next to me anymore. He was gone.

And I was thinking, “Well, if I don't remember him leaving, what else happened that I don't remember?”

David: Well, you said from the previous one that you recovered memories in which they were saying things to you like, “You will forget. You will forget.”

Corey: Yes. Yes. And that hasn't happened yet, anyway, in this. I don't have any recollection of that.

David: Okay.

Corey: But it was after that the meeting was over, and the two airmen where escorting me out the way I came. And I was feeling pretty indignant. I was not happy with the way I had been treated.

So I was kind of trying to put a air on of a little bit of confidence or cockiness. And it lasted maybe about 10 steps, because when they were bringing me down that steep ramp, my knee buckled – my bad knee buckled.

David: It's like instant karma.

Corey: Yeah. And . . .

David: Because the beings are all about you being in this state of positive service to others, Ascension-compatible consciousness, and you'd gone into this negative frequency.

Corey: I guess.

David: Wow!

Corey: But . . .

David: So your knee buckled?

Corey: Yeah, I was about halfway down the ramp, and my knee kind of buckled and twinged. It hurt. I was, like, “Ah!” And I almost fell off the side about 8 ft. down to the concrete.

David: Oh, wow!

Corey: And the airman behind me, he reached up and he grabbed my elbow like this, because I was falling.

And when he did, it twisted my back. I pulled a muscle in my back, and I couldn't go down the rest of the stairs.

And the airmen were mad. They were upset that I got hurt. And they were discussing that I got hurt in their custody while . . . under a big wig. They were worried about it. And they were discussing, should they take me back up the ramp or take me home.

And at that point, I said, if I have a vote, I'd like to go home, please. So . . .

David: Yeah, really.

Corey: Yeah. They looked at each other and then glanced back up the ramp, and then helped me the rest of the way down the ramp. And then they helped me walk all the way through my alley, all the way into my backyard.

And they were about to walk me in through my back door when I was like, “Wait a minute!” I thought about my family being in there, and it just . . . I had a visceral reaction.

And I said, “I’ll hobble to my couch and sleep there.” And . . .

David: Wow!

Corey: . . . they didn't say anything. They just turned around and jogged off into the dark.

David: Hm.

Corey: So I hobbled over, and I go to sit down on the couch, and I sit down, and before I can get my weight all the way back and get comfortable, a Blue Sphere shoots through the wall, never slows down, and snags me and picks me up.

David: Wow!

Corey: Just “shoosh” like that.

David: That's never happened that way before.

Corey: No-o-o-o. I was caught way off guard. And then I find myself standing in one of these ancient Mayan vessels that are made out of stone, that are giant cylinders – motherships.

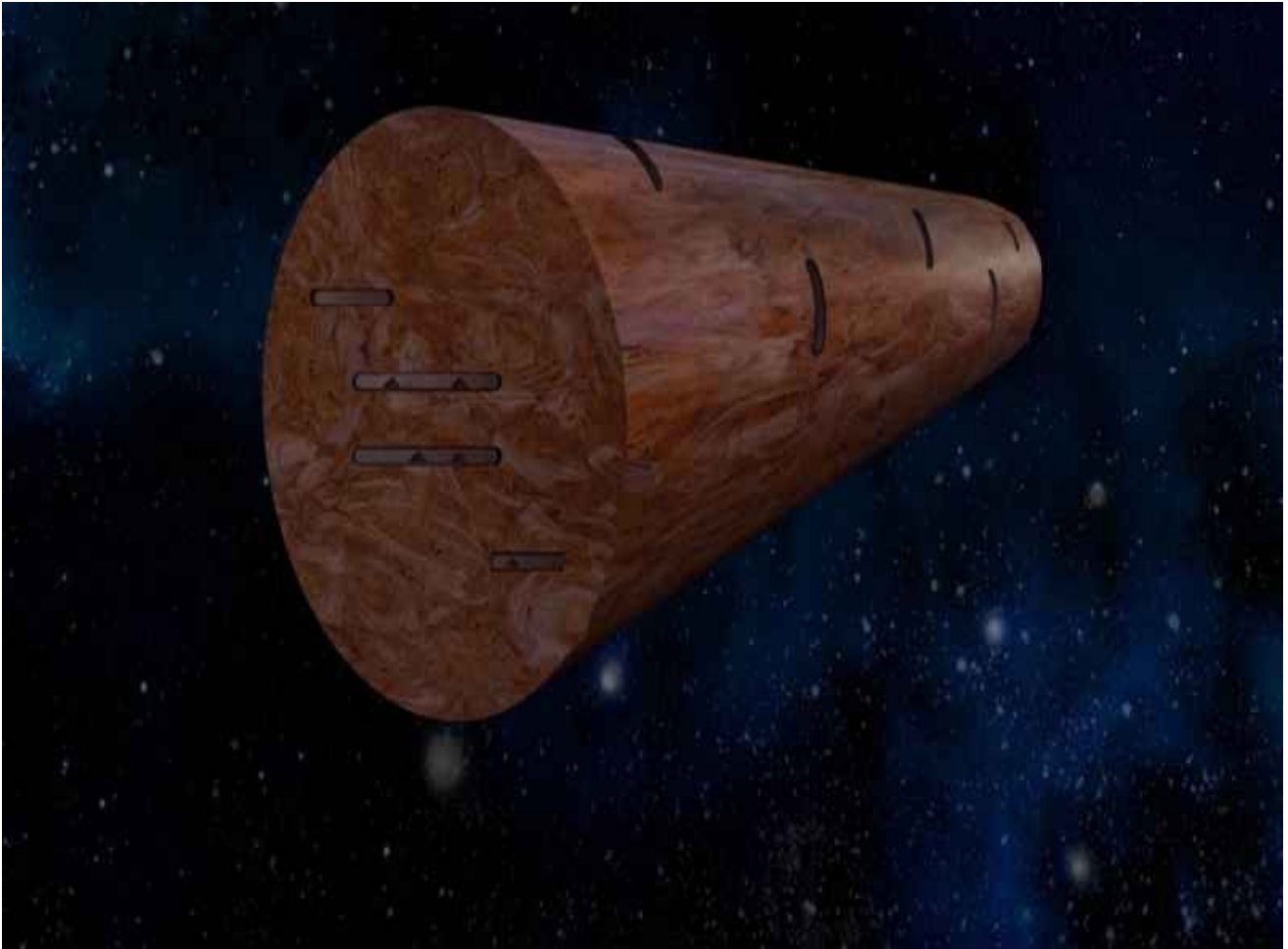

Looks like they were just cut out of the inside of a mountain and then teleported into space. It's like being in a cave almost.

And I'm standing in a very familiar room.

Before I even started shooting "[Cosmic Disclosure](#)" and right before . . . it was before I even started talking to you about this, I had had a detached retina.

And while having the surgery, I had shots in the eye a lot, and it brought back a lot of memories. And I went through a period to where I was depressed, upset. I couldn't hardly get out of bed.

And I was picked up by the Mayans, and that was the first time I ever saw Gonzales. He was with them. I didn't know him.

David: Oh.

Corey: He was translating for them basically because they wouldn't connect with me. They wouldn't interface with me.

And they went through a process where they put like a halo kind of thing on my head, and it went “thupt” sucked to my scalp when they did.

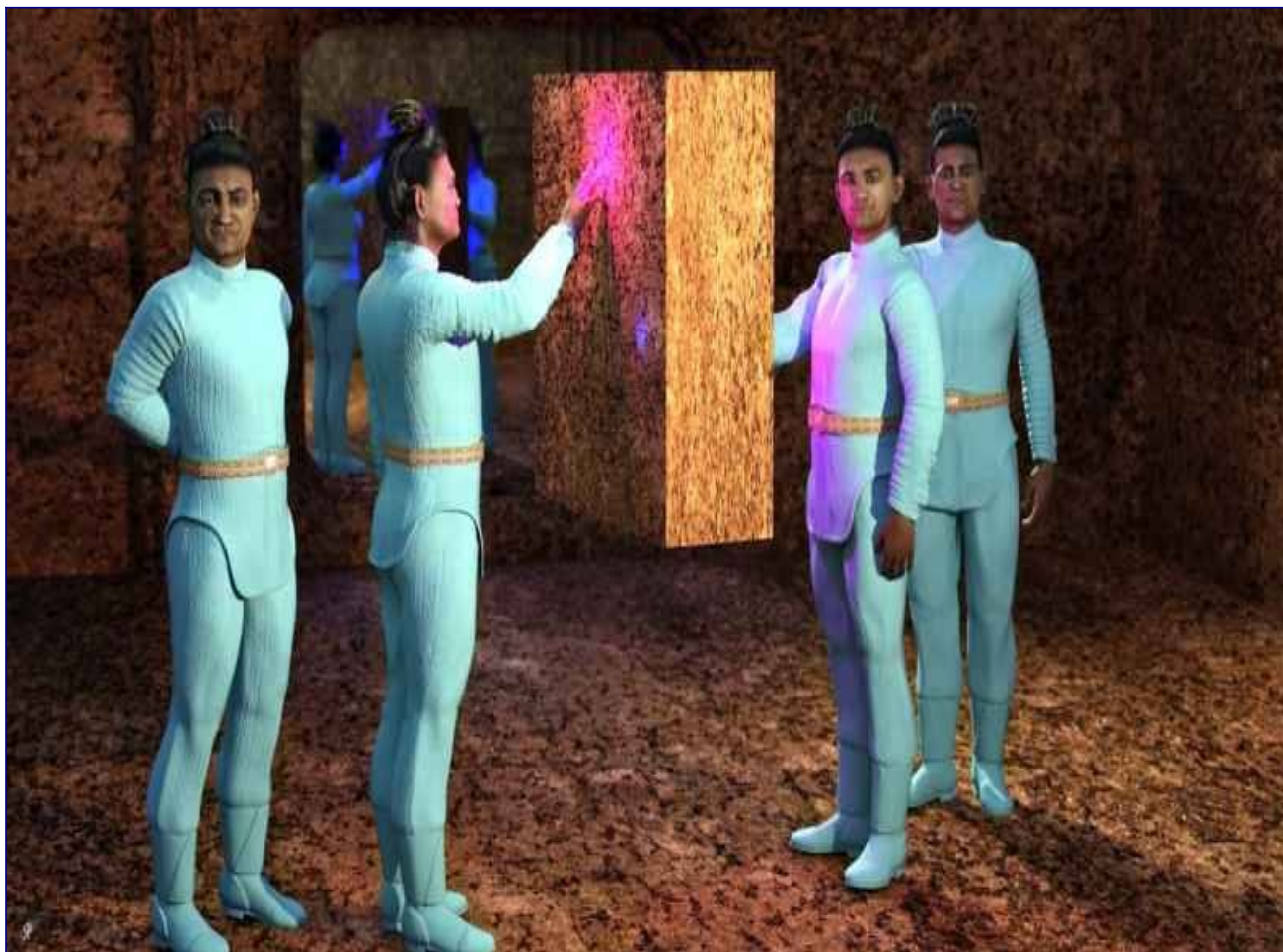

And they were running their hands over this floating rectangle that was just levitating in the middle of a room that was stone, and it was plain.

They were just doing this [**Corey** moves his hands around in the air]. And it was explained to me that they were doing work to help me disassociate from a lot of those traumatic memories, so that I . . .

David: Did they heal your retina as well?

Corey: No, I had already gone through that surgery.

David: Okay. So then what happened this time when you get there again?

Corey: Well, this time I see four of the Mayans standing in the background, and Gonzales standing a little bit in the foreground walking towards me.

And I was like, “What's going on?” And he wasn't really answering me.

He pulls up this stone that is a sphere. It's black. It's close to the size of a tennis ball, and he holds it up to my head, my forehead, and he starts doing like this [**Corey** moves his hand side to side]. And he's kind of got this concerned look on his face.

David: Hmm.

Corey: And then he kind of brushes the concerned look off of his face, and he asks me, “Have you been feeling strange or having memory issues?”

And I said, “Yes, as a matter of fact, I've been having more and more issues when trying to recall certain information and issues that I didn't have prior.”

And he kind of got the concerned look off of his face. He kind of wiped it off, and he said, “Well, actually, I'm kind of surprised that you're able to even remember your kids' names.”

And I was like, “What do you mean?”

He said, “Well, for someone who's been blankslated as many times as you have and spent so much time on the research vessel inside that magnetic field of the torsion drive,” he said, “a lot of people in the programs end up having neurological issues, early onset dementia, and things like that.”

And I commented . . . I was like, “Great. One more side effect from being involved in this stuff.”

David: Two of the insiders I know, Jacob and Henry Deacon, both have had extensive nerve system problems, just like you said.

Corey: Yes.

David: Same thing.

Corey: Yes. That's very common. He basically just performed this exam on me, and we had a short conversation, and he said, "Well, I guess it's time to get you back home."

I said, "Wait a minute." I said, "Are you forgetting something?"

He turned around and looked at me like, "What?"

And I pointed at my knee, because I was standing with all my weight on one leg, and I had my knee kind of limp on the other side.

And I left out, when I first got there, I was hurting. My back was quivering. My knee was hurting. And one of the ancient Mayan people reached up on the same floating piece of stone, just three fingers, went like this [rubbing action], and all of a sudden the pain went away.

David: Wow!

Corey: And the pain was gone during our conversation, but I still . . . my back was stiff and my knee was . . . it was obviously still damaged.

David: So what did he say when you said, "Wait a minute?"

Corey: He said, "I'm sorry. We can't help you out with this one." He said, "You should be fine in three days or so if you take it easy." And I was obviously going to have a question after that.

He turned around and started walking towards the four Mayans, and I was going to wait for him to turn around. I was going to ask him a question about, "Why can't you help me out?"

And then a Blue Sphere came, not as quickly as last time, stopped in front of me, and I just read from the situation that the conversation's over. And I indicated that I was ready to go home. The Sphere took me back home.

I was right in front of the couch again, and immediately, my back started spasming. My knee hurt real bad, so I kind of flopped down on the couch and went to sleep. And that was the end of that encounter.

David: Well, I think it's important to point out that neither you nor I or anybody else doing this are exempt from karma. And even if you have access to these beings, they're not just going to interrupt any type of karmic procedure that we have to go through.

So, I guess, that's probably been explained to you before, right, by the Blue Avians, that they can't just take away certain things from you because you might need to experience them for whatever reason, right?

Corey: Right.

David: So did you, in fact, have it clear up after a few days like they said that it would?

Corey: Yep. After about three days, I still had a little bit of problems, but it was good enough to where I could . . . I was mobile again.

David: Is there anything that you'd like to say as sort of a summary or concluding statement? We've had some things here that are a little upsetting, like you sleepwalking and getting re-abducted.

What do you think the re-abduction was about from the MIC group?

Corey: Them trying to confirm their prior test results that some of the brass just . . . They could not accept this information. Just could not accept it.

David: Do you think Gonzales holding that sphere was helping to clear up some of the mind wipe effects that they were causing on you by doing this to you over and over again?

Corey: It seemed as though he was scanning and reading something, and I'd left out . . . I'd asked him why this had happened.

And he said it was all according to plan. And I said, "What plan and how come I'm not privy to this plan?"

And he said everything unfolded the way it was supposed to. He said, "Please just trust me for a little bit longer, and I'll explain it all later."

David: Do you think it's possible that when they interrogate you, that they're actually getting information that's going to change their organization somehow as they realize this is true?

Corey: Yeah, I think they got some sort of information from me that the Alliance wanted them to get.

David: Very interesting. Well, that's all the time we have for in this episode. It's very enigmatic stuff going on here, and I'm sure that much more will happen in the future. This is an evolving story.

And this is just another chapter in something that apparently has some very exciting stuff for us coming up in the future.

This is "[Cosmic Disclosure](#)." I'm your host, [David Wilcock](#) here with **Corey Goode**, and I thank you for watching.

Cosmic Disclosure: Law of One and The Secret Space Program: Technological Salvation

Season 6, Episode 13

[David Wilcock](#): All right, welcome to "[Cosmic Disclosure](#)". I'm your host, [David Wilcock](#). I'm here with **Corey Goode**. We are now going to be getting into an astonishing number of correlations between what's printed in The Law of One and what he's been telling us on this show about the infamous and dreaded Draco Alliance.

So, **Corey**, welcome to the program .

Corey Goode: Thank you.

David: So we've already seen something that's gone way beyond what you thought The Law of One would have in terms of the amount of specific detail.

I know you've never seen any of this stuff before, and I think it's really cool we're going to get this on camera – your first takes as we go through it. And this really, in my view, what you're about to see here is the best information on the Orion/Draco that's in The Law of One.

Now, before we go any further, and I do think you said this on a show before, but I just want to reiterate it now. There is a connection between the Draco and the constellation Orion, correct?

Corey: Yes. And I don't know if that's where they came from, but there are some symbols that are prominently displayed that are Orion symbols.

David: Symbols on their uniforms, on their ships?

Corey: That people have seen displayed on ships, inside ships.

David: Really?

Corey: Right.

David: You've never said that before.

Corey: Triangles . . .

David: We're getting this on camera for the first time. You've never said that before. Wow!

Corey: Right. Triangles with the Orion symbol.

David: Well, I know the Apollo mission, some of the Apollo missions, the patches, had the A and then there's the Belt of Orion in the middle of the A.

Corey: It's the Belt. Yeah. In the triangle, the Belt.

David: Oh, wow! So this explains why The Law of One would call them the Orions, because that's the logo they're using.

Well, I have heard from other insiders that they have a big settlement in Orion, that they've controlled some major sectors there.

Corey: Yeah. I do know that they have been in just about every star system that we can see with our naked eye.

David: Right.

Corey: And they have caused problems in each of those star systems, conquered some of them, been kicked out of others.

David: That's all going to be in here, so let's hit the ground running. This is going to be incredible for you.

LAW OF ONE ON SSP

[8.12](#) Questioner: At the same time you mentioned that some of the landings were of our peoples, you also mentioned that some were of the Orion group [which is their name for the Draco. It's very obvious. We'll get into all that later. Very obviously the same.]

[We] talked a little about the Orion group, but why do the Orion group land here? What is their purpose?

David: This gets really interesting.

Ra: . . . Their purpose is conquest, unlike those of the [benevolent] Confederation who wait for the calling.

David: And the calling means we have to ask for their help. They can't help us without our freewill permission.

So conquest. And would you say that's the Draco in a nutshell right there?

Corey: That is their mandate. They conquer and not only that, they have co-opted part of the Secret Space Program to assist them in conquering.

David: Wait til you see what's in here because it validates that completely.

Ra: The so-called Orion group calls itself to conquest.

[8.13](#) Questioner: Specifically, what do they [the Orions or Dracos] do when they land?

Ra: There are two types of landings.

In the first, entities among your peoples are taken on their craft and programmed for future use.

David: Now, what do you think that means?

Corey: There are a lot of individuals that have no idea that they have been picked up by any type of non-terrestrial. A lot of these people are harden skeptics even, and they have been programmed to be triggered by certain events in the future to act a certain way and to perform certain tasks.

David: Wow! Wait until you see what comes next.

Ra: There are two or three levels of programming.

David: And this gets really bizarre.

Ra: First, the level that will be discovered by those who do research. [Abduction]

David: And I just put in here in parentheses my guess is that they mean abductions. That seems pretty obvious.

Ra: Second, a triggering program. [Mind control]

David: That definitely seems to be mind control, which is what you were saying, but wait until you see number three now.

Ra: Third, a second and most deep triggering program crystallizing the entity thereby rendering it lifeless and useful as a kind of beacon. [Programmable Life Form]

David: And that seems to suggest the idea of a programmable life form. Have you heard about the possibility that certain organic, seemingly biological life forms could become programmable?

Corey: Yes, with the help of nano technology.

David: Right. So, this programming, this deeper level they're talking about would involve some sort of AI compromise.

Corey: Sounds like it.

David: And what they're saying here, if you read it carefully, it becomes lifeless. The AI could take over someone's body so much that traditional biological life isn't even really a factor any more.

Corey: Yeah, I haven't heard that part.

David: Do you think it could go that far?

Corey: It could.

David: Yeah. Well, we've heard from Dr. Steven Greer about the PLFs or the Programmable Life Forms, that there are these . . . Some of these Greys apparently are not really alive.

Corey: Yeah.

David: They're like a bio-robot.

Corey: Right.

David: Does that line up with what you saw?

Corey: Yes. Some of them are remote controlled like avatars.

David: Right, exactly. So this, again, way too advanced for what you should have seen in 1981.

Ra: This is a form of landing.

David: That's one of the forms, but then there's another one.

Ra: The second form is that of landing beneath the Earth's crust which is entered from water.

David: Now you're smiling. So are there bases that the Space Program has that are on Earth that you enter in from the water and they are under the crust?

Corey: There are bases for many non-terrestrial groups and terrestrial groups that are below the ocean crust and the Earth crust where entrances are underwater.

David: Wow!

Corey: Yes.

David: And they're specifically talking about the Draco here. The Orions.

Corey: Here they're talking about the Draco, but the Super Federation – they call them 'embassies' in the Secret Space Program.

David: What would we see in one of those portals in the ocean? What would it look like when they go in?

Corey: Well, they are giant . . . They're like a cave systems.

David: Okay. It's not like an iris opens and closes necessarily.

Corey: Well, some of them , , , they have put holographic types of technology to cover them, and some of them our military have put types of material that will reflect radar, sonar, in the same manner that the surrounding rock and material will to camouflage it.

We have electromagnetic powered, basically, submarines as well . . .

David: Right.

Corey: . . . that travel in and out and they travel beneath the crust and then within all of these rift zones under the crust.

David: I bet you didn't expect to see this, huh?

Corey: No.

Ra: Again, in the general area of your South American and Caribbean areas and close to the so-called northern pole.

David: But the point is here, notice they say, “Again, in the general area of” the Bahamas and Chile.

Corey: Yeah.

David: Right? So what they're saying is that the Draco bases and the human bases are joint bases. Right? Because they 'again', and that fits with what you're saying as well, right?

Corey: Many of them are joint.

David: So you would have these Dracos working alongside humans in underground bases, just like it says here and undersea.

Corey: Uh-huh.

[8.14](#) Questioner: What [is] the objective with respect to the conquest of the Orion group?

David: He doesn't . . . This is only Question 8. He's only been doing this for less than two weeks now.

Corey: He's asking why . . .

David: Yeah.

Corey: . . . the Orions conquest?

David: Why the Orions want to do this, because he doesn't really get the negative agenda yet. This is before he understood loosh, before he understood all that stuff that comes out.

Ra: As we have said previously, . . .

David: This is an amazing answer.

Ra: . . . their objective is to locate certain mind/body/spirit complexes [ie people] which vibrate in resonance with their own vibrational complex, . . .

David: Meaning people who are powerful and think of themselves as elite and very evil.

Ra: . . . then to enslave the un-elite, as you may call those who are not of the Orion vibration.

David: So notice it says here they're not going to come in and conquer directly. They've got to contact the planetary elite.

Now, you said that the first group the Draco contacted was who?

Corey: The Nazis.

David: Right. So this fits in, doesn't it?

Corey: Yes. The Nazis were very much of the same vibration as the Draco.

David: And what were the Nazis trying to do?

Corey: They had the exact same agenda to subjugate the world, reduce population and control it.

David: It lines up very, very nicely. So now we're going to skip from Question 14 to 23, just to keep things moving.

[8.23](#) Questioner: The most startling information that you've given me, which I must admit I'm having difficulty believing, is that [the] United States has 573 craft like you describe.

David: Because there was nothing like this in UFO lore at the time.

How many people in our government are aware that we have these . . . how many total people . . .

David: And notice the wording. Again, you've got to be so careful how you ask these questions.

How many people of United States designation . . .

David: If he had asked it differently, he would get a totally different answer.

How many people of United States designation are aware of this, including those who operate the craft?

Ra: . . . The number of your peoples varies, for there are needs to communicate at this particular time/space nexus so that the number is expanding at this time.

David: Now, I believe that what they mean here is there's a need for people in the United States who know about this to communicate with the Breakaway Civilization, because he didn't ask about that. He asked about the U.S. But wait til you hear this.

Ra: The approximate number is one five oh oh [1,500].

Corey: That's not many.

David: What do you think about that estimate based on the classified world as of 1981, the number of people that are on cosmic top-secret or higher clearance level, the need to know, and are still actually living in the U.S. and are not part of this Breakaway Civilization?

Corey: I would say the numbers are not that different.

David: That's pretty close to what you'd estimate?

Corey: You know, a little more now, but it's still a very small number of people that have the full knowledge. A lot of people think they have it, but the people that are, as you say, communicating with the Breakaway Civilization for logistics is a very small number.

David: And when I spoke to Hoagland's insider, Bruce, recently, about this and asked him the same question, he said there's about 3,000 here on Earth who know everything right now, which is only double that number. So this is . . . It's a very tightly controlled thing.

And so then they say:

Ra: It is only approximate for as your illusory time/space continuum moves from present to present at this nexus, many are learning.

David: So they're saying the number's going to go up quickly.

[8.24](#) Questioner: Where are these craft constructed?

David: Wait until you see this. Nobody knew about Area 51 back then. Okay? It was not out in the open.

Ra: These craft are constructed one by one in two locations:

. . . in the desert or arid regions of your so-called New Mexico

. . . and in the desert or arid regions of your so-called Mexico, both installations being under the ground.

David: Does that line up with anything that you saw?

Corey: Yes. Ha, ha.

David: Ha, ha.

Corey: That's very interesting. There are facilities in Mexico . . .

David: Really?

Corey: . . . out in big desert regions with mountains separating them, and I don't know exactly where it is geographically, that have underground areas where they construct some of the parts of the technology, at least they used to. I don't know if that's still the case. This is back '80s, '90s.

David: Well, this is a leap of faith for me because we have not talked about this, and I just threw you in. I didn't know . . . I've never heard an insider before tell me that there was actually underground bases in Mexico.

Corey: And I don't even think the Mexican government is aware of them.

David: They talk about that.

Corey: Oh, okay.

David: Yeah. Check this out. What about New Mexico? Let's just . . . Have you heard about New Mexico with underground bases?

Corey: Not so much . . .

David: Obviously Nevada.

Corey: Yeah, Nevada, Utah and a few . . . not so much New Mexico . . .

David: Okay.

Corey: . . . when it came to constructing things.

David: But it's possible.

Corey: Oh, yeah, yeah. I'm not privy to all information.

David: And a lot of this stuff would be done in the desert.

Corey: Of course.

David: So now he's doing a double take.

[8.25](#) Questioner: Do you say the United States actually has a manufacturing plant in Mexico?

Ra: I am Ra. I spoke thusly.

Corey: That's what I said.

David: Ha, ha.

Corey: Ha, ha.

David: And then he's got to beat him down for asking lame questions.

Ra: May I, at this time, reiterate that this type of information is very shallow and of no particular consequence compared to the study of the Law of One.

Corey: That . . . Raw-Tear-Eir, when I ask questions or bring up concerns, often I hear “it's of no consequence”.

David: Really? The same wording as this?

Corey: Yeah.

David: It's funny too because on this show most of what we do is what they would consider transient information, but yet they've been trying to get you to focus on this message . . .

Corey: Yes.

David: . . . which is all they really care about – the study of The Law of One, and it says it right here.

So even though we might be fascinated by this stuff, for them it's like, “Come on, you guys, focus on information that matters as much in 10,000 years as it does today.”

Corey: And with my communications with them, they keep wanting me to go back to the spiritual, you know, message.

David: Well, that's why we're doing this. Ha, ha. Because ultimately if somebody watches this show, but they don't get the material they need to know spiritually to be able to ascend, you know, what's it going to get you when the solar flash happens? Ha, ha.

Corey: You'd be seeing a lot of spots. Ha, ha.

David: Ha, ha.

THE ORION GROUP

[7.14](#) Questioner: You mentioned Orion as a source of some of the contacts of UFOs.

Can you tell me something of that contact, it's purpose?

Ra: . . . Consider, if you will, a simple example of intentions which are bad/good.

David: Let me just toss a little explanation in here. In The Law of One material, there's never an absolute. So if something is bad, it's bad/good as oppose to good/bad.

Corey: Is that point of view, perspective thing?

David: Yeah, because ultimately what they're going to be explaining here is that it's bad to us but it's good to the people that are doing it. They think they are doing good. So lets . . . and they're going to talk about Hitler. They use that as an example.

Ra: . . . Consider, if you will, a simple example of intentions which are bad/good.

This example is Adolf.

David: They don't usually ever use a last name.

Ra: This is your vibratory sound complex.

CHOOSING AND ENSLAVING

The intention is to presumably unify [the people] by choosing . . .

David: This is the intention of the Orion, the Draco.

Ra: [The Draco's] intention is to presumably unify [such as a planet or their empire] by choosing the distortion complex called elite from a social memory complex

David: So the social memory complex is their word for a planet, because they say we cannot tell you apart from each other. You are not distinguishable to us as individual beings. You're part of this social memory complex. You're one mind in symbiosis with the Earth.

So these empires want to conquer those minds. They've got to get the whole planet to do this.

So that's what they're talking about.

Corey: And that's what the Inner Earth people said.

David: Oh, really? Tell me more.

Corey: Before they had more developed beliefs and understandings that their earlier people believed that they were produced and came from the Earth and that they were consciously connected to the Earth and stewards of the Earth and their consciousness returned to the Earth.

David: Okay. Yeah, so that fits perfectly. So they're looking at our social memory complex. They're seeing the people that are here on Earth. And they look for the elite. They look for the most powerful, the most wealthy, the most trending towards evil.

Corey: Corruptible.

David: Yeah.

Ra: . . . and then [after they've chosen those elites, they] enslave, by various effects, those who are seen as the distortion of not-elite.

David: Which is pretty straightforward.

Ra: There is then the concept of taking the social memory complex thus weeded and adding it to a distortion thought of by the so-called Orion group as an empire.

David: So this is pretty straightforward so far. The idea of the weeding being they want to weed out any resistance to their tyranny.

And as you know, the Draco are not just going to show up. Right? It's not their pattern to just appear in our skies and show up as these giant reptilians as say, "Here we are." Right? That's not the way they're doing this.

Corey: Right. They're subject to certain cosmic laws that they have to find loopholes and to be able to skirt the laws.

David: That's exactly what's about to be explained.

Corey: Okay.

RANDOM ENERGY

Ra: The problem facing them [the Draco, the Orion] is that they face a great deal of random energy released by the concept of separation.

David: Meaning they see themselves as separate from the One. Of course, this book is called The Law of One. Everybody's part of one mind. Service-to-Others is helping yourself, etc.

The Draco believe in separation, but that means betrayal happens all the time.

Ra: This causes them to be vulnerable as the distortions amongst their own members are not harmonized.

David: What they're saying here is it seems like there's this constant battle within the group itself and people getting overthrown. Is your data consistent with that?

Corey: I don't have any information about reptilians killing each other and fighting amongst themselves, but the information that I had in the meeting I attended where there was a Draco present, they also in their federation had insectoid-type beings and mantis-type beings.

Now, there could be some power struggle and stuff like that going between these groups and them.

David: But let's also say too that you have Cabal groups on Earth that the Draco are attempting to create as an elite and then keep them in their group.

Corey: Right.

David: So there's definitely been those kind of problems.

Corey: Yeah, yeah. Definitely.

David: Yeah. So this does fit very nicely. I mean, this is still pretty generic, but it's going to get a lot more specific.

DENSITIES OF ORION

[7.15](#) Questioner: What is the density of the Orion group?

Ra: . . . Like the Confederation, the densities of the mass consciousnesses which comprise that group are varied.

There are a very few third density, . . .

David: And that, of course, would be like your Committee of 300 types, Illuminati types, that kind of thing. That's what they're talking about.

. . . a larger number of fourth density, a similarly large number of fifth density, and very few sixth-density entities comprising this organization.

David: So the fifth density thing becomes very important now. We're just setting up the story right now.

THEIR NUMBERS ARE 1/10TH

Ra: Their numbers are perhaps one-tenth ours at any point in the space/time continuum, as the problem of spiritual entropy causes them to experience constant disintegration of their social memory complexes.

David: So let's talk about this. Would you say that from your information that that data of the bad guys being only 1/10th as numerous as the good guys out there flying around the universe, would you say that's approximately correct?

Corey: They're definitely outnumbered, and that's why they use other groups that they have conquered as proxy soldiers for them.

David: Right.

Corey: They have certain elements of our space program that fight alongside them to increase their numbers and their ability to govern their territory.

David: And what's happening with this SSP Alliance would be another example of the disintegration of their group, this spiritual entropy, because people keep turning on them.

Corey: Yes.

David: They keep losing out on their opportunities.

Corey: And that's happened, I've been told, the whole time they've been here. They haven't been in constant power. They've been in power. They've been kicked out of power. They've come back and regained power. It's been kind of an ebb and flow between different groups.

David: Another perfect correlation.

STO RESULTS IN STS

David: This is a very interesting line.

Ra: Their power is the same as ours.

The Law of One blinks neither at the light or the darkness, but is available for service to others and service to self.

However, service to others results in service to self, thus preserving and further harmonizing the distortions of those entities seeking intelligent infinity through these disciplines.

David: So I think that's a very interesting point, don't you? That the service to self path, they just want all the benefit. They want to take. They want to consume. They want to conquer. They want to control.

But here it's saying that if you help people, that you then are helping yourself.

Corey: Right.

David: Is that consistent with the message that the Sphere Beings have been giving you?

Corey: It's exactly the same message. I mean, the message was to raise your vibration, to be more forgiving of yourself and others, to become more of service to others. It's the same.

David: And when we're working collaboratively like that, now we're able to gain benefit. It's not like you have to control people and dominate people to gain benefits for yourself.

When we start sharing, cooperating, forgiving each other, everybody gets to work, and everybody gets to benefit from that.

Corey: Correct.

David: Yeah. So this is a very important little philosophical point here that shouldn't be forgotten.

CONCEPT OF SEPARATION

David: So now we're going to get into the concept of separation.

Ra: Those seeking intelligent infinity through the use of service to self [like the Draco] create the same amount of power,

but, as we said, have constant difficulty because of the concept of separation which is implicit in the manifestations of the service to self, which involve power over others.

This weakens and eventually disintegrates the energy collected by such mind/body/spirit complexes [that's people here on Earth] who call the Orion group and the social memory complexes which comprise the Orion group.

David: So what are some of the key examples of the disintegration that we're seeing in the Cabal now that would fit in with this that you're aware of?

When you got introduced to the White Draco, they announced themselves as the Committee of 200. Right? Not 300.

Corey: Yeah, and it could be a different group. The people that were in suits, human beings that were in suits that were present, they introduced themselves as the Committee of 200.

David: So that would imply exactly what they're saying here that there's just this constant disintegration going on. It's breaking down. The alliances are fracturing. They can't hold it together.

Corey: In that very meeting, that Royal Draco offered to give up that very group and all of their foot soldiers for safe passage out of the solar system.

David: Right. And you can't run a group in which you're constantly betraying the members. And these Royals were like, "Just let us free, and we'll betray everybody else we've got."

Corey: When that occurred, it caused shock waves.

David: Again, it's perfectly mirrored right here. It's incredible.

SPACE-TIME AS A MEDIUM

Ra: It should be noted, carefully pondered, and accepted, that the Law of One is available to any social memory complex which has decided to strive together for any seeking of purpose, be it service to others or service to self.

The laws, which are the primal distortions of the Law of One, then are placed into operation and the illusion of space/time is used as a medium for the development of the results of those choices freely made.

David: So isn't that interesting? What they're really saying here is, space-time is not real. Time is not linear. It's an illusion in which we are being given a teaching mechanism.

And there is a relationship between the thoughts that we have and the actions we take and then what results.

So this is a basic point in The Law of One, which I know you've validated many times. How does what you've heard about the nature of time fit with what we just read here?

Corey: This is exactly what I've said. And I receive emails that what I stated is ridiculous of space and time not being linear, or time not being linear in particular.

David: But yet what they're saying here is that it was built that way as an illusion so that we can learn and grow spiritually.

THE ORION GROUP

Ra: Thus all entities learn, no matter what they seek.

All learn the same, some rapidly, some slowly.

David: The goal is the same. We're all going back to the oneness.

SOCIAL MEMORY

[11.16](#) Questioner: What do the crusaders do?

David: This is where it gets really interesting about how the Draco take over a planet. And they get really specific now.

Corey: Are they calling them crusaders?

David: Orion crusaders, Orion empire, Orion confederacy. They use those terms.

Ra: The crusaders move in their chariots . . .

David: And that, as it turns out, is spaceships, ships of war. They explain the chariot term is a term of war.

Ra: The crusaders move in their chariots to conquer planetary mind/body/spirit social complexes . . .

David: Here's the key line, **Corey:**

. . . before they reach the stage of achieving social memory.

David: Now, what that implies, and we're going to get into more information about it, is that there is a point at which time our planet unifies in consciousness.

And once that happens, they have no ability to do anything more to us at that point.

Corey: Absolutely. And that's what I've been talking about with the co-creative consciousness. Once we realize the power that we have, they cannot manipulate us or have any control of us whatsoever.

David: And one of the things that I think is interesting is this is 1981. Now with the Internet, we have this unification of knowledge available to us. So that is the stepping stone to social memory where all information is available to all people.

So it's getting very edgy for these guys already. They can't hide things anymore. So this is really interesting because it's basically saying once we ascend, once we go into that global consciousness, there's nothing more they could ever do again to hurt us.

Corey: And that's what the elites use – television, media, all these different mind control methods – to achieve is to keep us ignorant of our co-creative mass consciousness and how we're connected.

David: Because once we get it, they're done.

Corey: Yes.

[11.17](#) Questioner: At what stage does a planet achieve social memory?

David: It's a very important question.

Ra: . . . A mind/body/spirit social complex [that's a planet of people] becomes a social memory complex when its entire group of entities are of one orientation or seeking.

David: Now think about this. It says in harvest the negative are plucked out. So once that harvest event occurs, the negative aren't there anymore. That collective mind becomes positive.

Corey: And also, that's the root of the divide and conquer method or tactic . . .

David: To stop us from unifying.

Corey: . . . that the elite use. Right.

David: You got John Lennon writing songs like “Imagine”. They don't want that to get out there. As soon as he's ready to come forward again with this new rebooted music career, he gets “assassinated” by “a lone nut gunman”. So they're trying to control that from going too far in that direction.

So **Corey**, this is something else that I want to talk about. You said something to me in the car today that blew me away. We've never said it on the show. Heard it from you for the first time.

You said that you were aware of there being three out of the five Sphere Being Alliance groups that have showed themselves so far.

Corey: Right.

David: But you've had new briefings that we haven't discussed. Could you tell us what those new briefings said, because it's very relevant to this?

Corey: Well, it isn't exactly a new briefing. I've known this for a little while, but I just haven't shared it.

David: Okay.

Corey: The two so far . . . the two other beings or groups of beings, they stated that they will present themselves to all of humanity during the time of transformation and will reside with us for an age.

David: So we're not going to see them until a transformation occurs.

Corey: Until right before or during the transformation.

David: What is the transformation?

Corey: I'm assuming that it's some sort of energetic event.

David: Like the idea of the solar flash that we keep talking about.

Corey: Right.

David: So what you're saying is that the other two of the five Sphere Being groups show up for the first time as the solar flash goes off, and there are boots on the ground here with us as this happens.

Do you think that once those people show up and the negative is removed that this verse becomes true that we're now all of one direction or seeking?

Corey: Yes.

David: Is that the idea?

Corey: Uh-huh.

David: And those people are helping to protect us so those negatives can't come back?

Corey: I don't think they're here to protect us. They'll be here to guide us through the rest of our transition as . . .

David: In protecting ourselves.

Corey: Right.

David: It's incredible how much this lines up with everything that's happening to you.

ALL KNOWLEDGE AVAILABLE

Ra: The group memory lost to the individuals [on the planet] in the roots of the tree of mind then become[s] known to the social complex, thus creating a social memory complex.

David: How do you think this could apply to some things that you've seen? Is it possible for a group of beings to become telepathic enough that there's like a telepathic Internet, not technological, but that knowledge is available like, for example, in the Inner Earth, the library?

Corey: Recently, in the last several months, Ka-Aree started communicating with me telepathically in like a telepathic conference where . . .

David: And you were pretty unsettled about that at first.

Corey: Yes. And she told me that before long, this will be commonplace with all of my people and really kind of made me . . . was trying to make me feel kind of silly. But I always request face to face communication because of . . . I don't want to have trickster beings come in and cause problems.

David: Well, we could dig up another episode later on of quotes from The Law of One explaining protocol, and that if you are in that Christed state, or the White Light state or the State of Unity, whatever religious term you want to use, the prayerful, loving, centered, peaceful, White Light, telepathic communication is totally secure at that point.

Corey: She's probably there, but I don't know if I am.

David: Ha, ha.

Corey: Ha, ha. But that is definitely how that group communicates. They sit around and have conference calls, but it's all telepathic.

David: So if these two new groups are going to come in and help usher us through this change, are the Inner Earth beings going to come to the surface for a while as well and work with us directly? Or are we going to be going down there? Do you know anything like that?

Corey: I have no idea. I do know that the Inner Earth groups are petitioning to have some sort of treaty that was signed just after the time of Muhammad about preventing open contact to have that amended so that there can be more preparation work done openly.

David: All right. Well, there's a lot more really cool stuff here. So let's keep going.

Ra: The advantages of this complex are the relative lack of distortion . . .

David: This is very, very dense verbiage.

Ra: The advantages of this complex are the relative lack of distortion in understanding the social beingness and the relative lack of distortion in pursuing the direction of seeking, for all understanding/distortions are available to the entities of the society.

David: So what this is saying is that once we achieve this social memory – and that's what repels these guys – that now we are unified in our beingness. We're unified in our seeking, and all knowledge is available to everyone.

So it seems like with the Inner Earth beings that they're already there.

Corey: They are.

David: And that's the fourth-density change.

Corey: Yep. They already have that experience now.

David: And it would appear from this that once we go there, that all these embassies, all these Draco groups, they're not going to be allowed to stay in our planet or around us at all.

Corey: Well, when that happens, the energy changes are going to be incompatible for them to even be here.

David: Ah, I see. All right. So now what we're going to do is get into the actual method of how the Draco try to conquer a planet, which for people who don't really understand these cosmic laws, how things have to be authorized, it would appear, oh, it's an alien invasion just like you see in the movies. They swoop in, guns a-blazing.

That's not what you're going to see here. Check this out. And this is exactly what you've been telling us.

HOW IS IT DONE?

[11.18](#) Questioner: Then we have crusaders from Orion coming to this planet for mind control purposes.

How do they do this?

Ra: As all, they follow the Law of One observing free will.

Contact is made with those who call [them].

David: And we know who that was. You said it started in the 1930s.

Corey: Well, before that even.

David: Right, with these Germans and then the military-industrial complex.

Ra: Those then upon the planetary sphere [that's people like us] act much as do you [that's this Law of One group] to disseminate the attitudes and philosophy of their particular understanding of the Law of One, which is service to self.

David: So how are we seeing this service-to-self philosophy being disseminated on Earth right now? What would be some examples?

Corey: Well, this call went out way before the 1930s. They've been dealing with the elites for thousands of years.

David: Right.

Corey: So for one, the money system. It's been called the Babylonian Money Magic System – Slave System. It's set up as a way of controlling us and mind controlling us into thinking that materialism is the most important thing, keeping up with the Joneses.

You've got to have a nicer car than the neighbors or at least comparable. That is the mindset that they tried to instill in us.

David: Might makes right.

Corey: Might makes right.

David: Manifest destiny.

Corey: And they want people to be caught up in all the lower vibrational traps of ego, vanity, all those . . . greed . . .

David: Pursuing things, celebrity.

Corey: Right.

David: What about these movies and music videos and so forth that keep having satanic type of imagery in them, satanic symbolism. Do you think that would be a part of that philosophy as well?

Corey: Yes. That's to affect a person's consciousness and to lower their vibration to keep them not looking to more spiritual information that will raise their vibration.

David: So the game really is that they have to get us to be enslaved by our own free will.

Corey: Right.

David: Because that's the rules that they have to follow. Isn't it stunning that all this stuff is right there in The Law of One yet again? So it says:

Ra: These [people] become the elite.

Through these [these elite], the attempt begins to create a condition whereby the remainder of the planetary entities are enslaved by their own free will.

David: It's right there in this Law of One material.

So that's all the time we have for in this episode. Once again, you're seeing astonishing . . . I mean, did you know that it was this close with what you've already been hearing?

Corey: No.

David: It's pretty amazing, isn't it?

Corey: It is.

David: Yeah. So that's all the time we have for in this episode of "[Cosmic Disclosure](#)" - amazing connections between The Law of One and now the Draco.

We'll see you next time. Thanks for watching.

Cosmic Disclosure: Life After Disclosure

Season 6, Episode 14

[David Wilcock](#): All right, welcome back to "[Cosmic Disclosure](#)". I'm your host, **[David Wilcock](#)**. We're here with **Corey Goode**, and in this episode, we're going to kind of go into dessert instead of always just eating dinner, the dessert being what happens when we have life after Disclosure.

Here to talk more about it is **Corey Goode**. **Corey**, welcome to the program .

Corey Goode: Thank you.

David: We spent a lot of time talking about aspects of your testimony that are going to be very hard for people to swallow given the learning curve, the amount of novelty of what you're describing, how unusual this is.

Are you seeing a positive future coming out of all this stuff that we're doing on this show? I guess that's where we should start.

Corey: Well, whether our future is positive or not is still in play. That is fully up to us. But I think that what we're doing on this show, and what others are doing in this field, are definitely bringing us closer to some sort of a Disclosure.

David: You mentioned that we may not have a positive outcome, and that depends on us. Could you be a little bit more specific, because that's a little provocative?

Corey: Well, people that heard my update, heard me speak in my update, when Tear-Eir said that there is an optimal timeline that we are trying to achieve, but us as human beings, our co-creative consciousness, are directing us on this path.

So if we don't get out there as a community and help raise the awareness and consciousness of others, then we're not necessarily going to find ourselves on that optimal timeline.

David: Well, I guess then before we get to dessert, what would the suboptimal timeline potentially look like? Are we dealing with a catastrophic type of reality at some point?

Corey: It's speculation. We don't know. There are so many different realities that we could create for ourselves. As a group consciousness being, we haven't decided where we want to go yet, and we're in the middle of making that decision right now.

David: So let's say that that consciousness starts to make better choices. What would be some of those steps that would be maybe a more predictable through-line of Disclosure?

So what might people start to see that you could say now that they can go back and say, “**Corey** said that and boom!”

Corey: Well, we're definitely going to start having more reports, photos, video, of these triangular-shaped craft and some of these oval-shaped craft that they use. They are planning on doing a Partial Disclosure event to where they're going to just tell us about a program that they have in low-Earth orbit – a couple of satellites and these triangular locus craft that take off that the Air Force controls.

David: But wait a minute. You've never mentioned on this show, at least, triangular locus craft. What do you mean by that?

Corey: Well, these triangular craft that people see that everyone labels TR-3B.

Cosmic Disclosure: Interview with the Insider

Season 6, Episode 15

David Wilcock: All right, welcome back to “[Cosmic Disclosure](#)”. I’m your host, **David Wilcock**, and I am so glad to be bringing you none other than **Pete** Peterson. So, **Pete**, welcome to the show.

Pete Peterson: Thank you, **David**.

David: When you first started talking to me, one of the things you said was so surprising about an extraterrestrial experience that your family went through with you.

Pete: My parents had a big formal English garden out behind our house.

David: Okay.

Pete: And had a nice raised gazebo, orchestra stand, whatever, and they did a lot of city events. This town was about three blocks long, maybe four.

David: Ha, ha.



Pete: But people would come and have their wedding ceremonies in the formal garden on the little trellis, grape arbor stand that was there, a raised stand.

David: Okay.

Pete: And we were having this . . . I was 10 years old. I remember that. And we were having this wedding there.

And just about as they were to say their vows, somebody said, “Holy cow!”, or words to that effect. “What’s that?”

And everybody turned and looked. And for the next hour, for God knows why, we were given a show of flying saucers. And that’s the only thing you could call them. They were every kind of shape and size you could imagine.

Some actually went through the air like subway cars, which you don’t see, but like a wild train at Disneyland. And they had little round holes, and you could see that there was something inside the hole, because there was light inside like there would be from an airplane.

David: What were some of the shapes that you saw?

Pete: Well, we had cylinders. And some went this way [vertical] and some when this way [horizontal], but they didn’t seem to turn this way [horizontal and then vertical], they just went this way [either stayed vertical or stayed horizontal while moving].

David: How many objects did you see in the sky, roughly?

Pete: Oh, at one time I might have seen 30.

David: Wow!

Pete: And most of the time you saw five or six. Then they’d come by and make passes. They’d come by and go straight up and disappear. They’d come straight down and turn and go sideways. They’d circle around.

There were four little cities there together. There’s New Plymouth, Idaho; Fruitland, Idaho; Payette,

Idaho; and Ontario, Oregon. It's right on the Snake River. Right off the backside of my father's farm, or my grandfather's farm, is the Snake River. And that's the division between Oregon and Idaho in western Idaho.

And so they were seen by about 6,000 people in those towns.

David: Wow! So you mentioned as far as shapes go that there were vertical cylinders, horizontal cylinders . . .

Pete: There were tops, I called them, because I had a toy top as a kid that you push this thing up and down and it would make noise and spin.



Then when you go back into history, you look back to the German bell [it] looked that way.



David: Right.

Pete: So there were some of them bell-shaped, and some of them were absolutely just round as this table and then just perfectly rounded on the sides like a traditional flying saucer.

David: Hm.

Pete: But some of them usually had like a cupola effect on it, like a saucer with a cupola, like a control area where you could see out of, and a bottom of it that was there.

And there were some of them that put down landing gear and lifted it. How, I would assume it was landing gear rather than . . . It might have been stabilization gear, but three legs would come down.

And they'd have a pad at the end about the size of this table [about 5', or 150cm, in diameter].

And some of them came within, I would say, as close to 60, 70 feet [183~213 meters] from us.

David: Wow! And how many people were in your party?

Pete: There were probably, I would guess, as many as 150 people at this wedding. We had a good-sized backyard, and it was full.

David: And this sighting obviously is so dramatic that there's no denying what's happening. It's not like . . .

Pete: No, it was no fiction of no one's imagination. Everybody had the same story.

David: Right. Were people screaming? Were they running and hiding? Or what was going on?

Pete: I think they were mostly absolutely jaw frozen. I mean, we were . . . It was stunning. And I mean, it was like you went to the final explosion of a fireworks show or something. I mean, it was just boom, boom, zoom, zoom, zoom, zoom, everywhere, all different times, but almost like it was coordinated because they didn't run into each other, and there were so many of them, they could have.

David: Huh. Could you see machinery or rivets on the outside or anything like that?

Pete: Some you could see rivet marks. Some you could see what I would now call weld marks. I mean, there were lines, but they weren't rivet heads or rivets. And some of them were homogeneous.

Several of them were, to me, obviously organic.

David: They had an organic appearance.

Pete: If you look at something engineered by man, it usually has right angles. It has straight lines.

David: Right.

Pete: You look at a banana, it's got lines on it.

David: Sure.

Pete: And it's shaped geometrically.

David: This goes on for an entire hour in front of this whole wedding party?

Pete: For an hour. I'm a kid. I'm 10 years old. I'm guessing it would have been about an hour.

David: One of the first things about you that I find interesting, **Pete**, is that your family has a direct connection to a very famous scientist. So why don't you tell us a little bit about that?

Pete: My grandfather on my father's side, a Peterson, was Tesla's right-hand engineer and confidante and a few other things at the Colorado laboratory.

David: So your grandfather had direct access to the Tesla knowledge and technology.

Pete: Right, and was a co-conspirator of that technology, if you would. The problem was that Tesla was . . . His thinking was very different from the thinking of the typical scientific world at the time he was here.

And his ideas were so revolutionary that they appeared to be non-founded. They were so far advanced that people didn't understand what he was talking about, and there aren't . . . The problem I've had my whole life, there aren't words to discuss reality the way it is.

We have to take ancient reality and use those words and then try to talk about it.

David: Hm. What year were you born?

Pete: 1940.

David: Okay. So somehow in eighth grade, you build an antenna whose performance far exceeds that which the U.S. government was normally using for military applications.

Pete: Oh, they didn't have anything like it.

David: They didn't have anything like it.

Pete: Like they had 1,000-watt radios, and they planned on them talking 280 miles.

David: Okay. 1,000-watt, 280 miles.

Pete: I had a 1-watt radio that I could talk anywhere on Earth.

David: Wow! I mean, let's just talk about results.

Pete: Well, the results were . . .

David: You say it could talk to anybody in the world, and if they test that . . .

Pete: You could take their little backpack radios they already had or their little walkie-talkies they already had, and you could talk 8 to 10 times farther.

David: Wow!

Pete: And if you were in a canyon, like where I live in a hole in the ground, if you live in a canyon, you do what's called nuclear vertical incidence skywave. You shoot it straight up in the air, and it goes straight up in the air and comes right back down, but it's on the other side of the mountain.

So now you can talk over the mountain, where before you had no communication over the mountain.

David: How did the government find out that you had done this?

Pete: Because I won the science fair project, and it was antennas, and antennas was a big thing for the government.

David: Okay.

Pete: I mean, they spend millions and millions of dollars. So I built a few antennas for the government. And as usual, I was going to patent it. And I went to patent it, and they said, "Sorry, this has already been taken by the government."

The first people that look at a patent are some agency of the government.

David: There was a journalist just in 2014 or 2015 who actually said that - this was a whistleblower, a Snowden-type of thing – that all patents must go through DARPA [Defense Advanced Research Projects Agency] first.

Pete: They have to go through somewhere.

David: Right.

Pete: And they do.

David: So that already did come out in the open.

Pete: So I never heard back from them, because I hadn't applied. If I'd applied for a patent, I'd have been paid and all this other stuff.

David: What was the first interaction that you had with the government? Did somebody come to your house? What happened?

Pete: This fellow from the local radio club that I was a member of, local ham radio club, had been involved in that kind of stuff, or was still involved in that kind of stuff.

They had people . . .

David: Government stuff?

Pete: . . . in every town that go to all the science fairs. They go to all the club meetings. They keep their ear to the ground.

David: From the government?

Pete: Yeah, they're paid by the government to do this.

David: Okay.

Pete: Some are agents, and some are just people that had the training, and they retire, and they're good people and have a good record, and they go to them and say, "Well, we'd like you to do this for us, and we'll pay you this much money." And they usually say, "Yes".

David: So he finds you at this science fair.

Pete: So he finds me at the science fair, but he knows me, because we're in the same club. And I give talks to the club all the time.

David: A ham radio club.

Pete: Ham radio club. I'm teaching them all kinds of things, and they can double their power and triple their power, or their apparent power, actually.

David: And how old are you at that point?

Pete: 14.

David: Okay. Do they show up to your house?

Pete: They showed up at the school.

David: Okay.

Pete: And took me and contacted my parents and said, “We're going to take him for a while.” Ha, ha, ha.

David: Okay.

Pete: This has happened numerous times. So they took me off, and we went down to some fort in Utah. I don't have any idea where it was. I mean, they drove me around in the middle of the night in circles and circles and crap and took me somewhere.

So I went down there, and I brought some antennas and some antenna manufacturing parts with me, and we made some antennas – showed them how to do it. That was the last I heard.

And then they called back, and they said, “We really want to thank you for this. You're an asset to your country, and you've helped out a lot, etc., etc., and we'd like to pay you something. Would X amount be enough?”

Well, my mouth went open, and my eyes went open, and I said, “Oh.” Then I remembered things my granddad had taught me.

He was a merchant. Ha, ha. I said, “Well, that would be about right.” Ha, ha. So they paid me.

David: Are we talking like five figures, six figures?

Pete: No, no, no. We're talking . . . yeah, five figures, just five figures.

David: Okay. That's very substantial for a . . .

Pete: In those days, it was . . .

David: . . . a 14-year-old kid.

Pete: Yes, siree.

David: So when is the next time that the government contacts you again after you build these antennas for them?

Pete: It was after the third science fair. Two guys come to the school, and they pick me up. And, I mean, in those days we don't have a lot of the problems we have today.

And they picked me up and wanted to take me down to the office. And they showed me . . . one guy shows me an FBI badge.

David: They were wearing civilian clothes at this point?

Pete: Civilian clothes.

David: Okay.

Pete: This is my ID. This guy is my driver. Turns out he was the guy, but he was driving.

David: Ah.

Pete: So they drove me around to talk to me for a while about the different science fair things I'd done and other things I was working on – other things I was doing.

And they said, “Well, we'd like to invite you to become a student of a very famous school.” Ooh, that's interesting.

So they took me to some office downtown, innocuous office.

David: Downtown Boise, Idaho?

Pete: Yeah.

David: Okay.

Pete: It was in the post office building, and it had a number on the door. And I went in there, and the guy that had been the driver became the talker.

And there were two other guys there and they had a long discussion, and they taught me about what White Star Ranch does.

Then they said, "We pick the brightest kids, and we put them into a training program. And we let you go through school as normal through your senior year, except that in the summers, you work for us, and we put you in super laboratories and things. That was . . . Wow!

And so when they found out I was interested in everything, they tried to give me a test. Well, they tested me for three days.

David: What do you think the White Star is?

Pete: It's the name of a . . . innocuous name for a place where they take care of sick, physically deformed, mentally deformed children, and where they take care of geniuses.

David: Okay.

Pete: And you go there and work with them, because I'll tell you, all those kids are geniuses.

David: These are children who have physical deformities, but their mind works?

Pete: Physical deformities . . . Their minds work like you can't imagine.

David: Okay. Okay, so the White Star Ranch has, then, some children with deformities, as you just said, . . .

Pete: Right.

David: . . . and some who are genius kids like yourself.

Pete: Well, they're like Stephen Hawking.

David: Right. Okay.

Pete: And that's just an absolute 100% example.

David: Right.

Pete: And they come in all fields. One of the groups that has one or two groups ahead of me was Westmoreland, Nixon, Kissenger, you know, that whole group of people.

They were one of the groups that was before me. Their thing was geopolitics.

David: So they worked at White Star Ranch.

Pete: No, they were . . .

David: They studied there.

Pete: They studied through White Star Ranch.

David: Okay. How many White Star Ranches in America were you aware of?

Pete: I eventually became aware of probably 20, just as a guess. Some of them were guesses, but they were good guesses.

David: So then 15 is when you actually go to White Star Ranch, age 15?

Pete: That's when I learned about it.

David: Okay.

Pete: And then we visited later.

David: Okay.

Pete: We signed up. My parents signed me away – made an agreement with my parents that they would trade me, and they would give me a college quality education.

David: When you actually start going to White Star Ranch more frequently . . .

Pete: No, no. It's not a place you go to. It's a place that governs you.

David: So you were able to do home study?

Pete: Well, no, I was shipped off to various places and met with probably 40% Nobel Prize winners, spent one on one with them for six months and then spent six months in the field that I'd learned about there.

David: So you're not going to regular school anymore?

Pete: Well, I was until the 12th grade.

David: Until the 12th grade.

Pete: But at the same time, in the summers I was totally tied up.

David: Okay.

Pete: And a couple three times we went to White Star Ranch so that we could learn to work with these Mentats.

David: Mentats?

Pete: Well, that's the only word I know of in the English language, and you'll find it in Dune.

David: These are the people who have . . .

Pete: These are people who have IQs of 300, 400.

David: Physical deformities?

Pete: And they usually have a physical deformity of some kind or a psychological deformity. They have people that have to be in the dark. They have people that can't be near other people.

You have people that have organs on the outside of their body as well as on the inside. You have people that are like Stephen Hawking.

David: But they are extremely bright.

Pete: EXTREMELY bright.

David: White Star Ranch is sounding to me, **Pete**, like it's a very sensitive, very classified . . .

Pete: It's a first intelligence layer.

David: Okay. And supposedly during this time, the OSS has turned into the CIA, but the intelligence community in the American government is still pretty young. But obviously what you're describing is a vast, well-funded, secretive organization of some kind.

Pete: Okay, I think I see where you're getting. We've had alien contact for the last probably 4,000 or 5,000 years. Now, when I say "we", I'm talking the society that exists today.

David: Okay.

Pete: The one before us destroyed itself.

David: Right. So are you saying then that the people who built White Star Ranch were working in conjunction with extraterrestrials?

Pete: They had to be.

David: Okay.

Pete: I mean, when I go back and look at how they trained me, the sequence that I was trained in, they had to be involved because they had to want to have somebody that could understand things down the line.

I was being trained for something way down the line.

David: Right.

Pete: I mean, it was obvious to me.

David: Why do you think they would be pulling in kids who are eighth, ninth grade to do that?

Pete: Because I had over 300 inventions that were 25 to 50 years ahead of anything out there. It was that I have a gift of perceiving from wherever. I didn't bust my butt learning things and then become a super inventor because . . . It's just because I had a natural profile.

That's what first picked me up, was I was fitting that profile.

David: Oh, you had a DNA profile that they tested?

Pete: Right, but at that time, it was before DNA. but it wasn't DNA, but it was a profile, things that I'd done.

David: Right.

Pete: I invented 50 things that were 30 to 40 years ahead, and most of them are things that nobody had even talked about.

David: Right. When was the first time that you became directly aware of extraterrestrial involvement in the White Star Ranch program?

Pete: I learned from that program. I learned that there were such things, because I was put down to help reverse-engineer things that were built for . . . obviously, I mean, there's no question about it.

It was . . . Well, how do these controls work on this craft? What do they do? What turns it on? What turns it off?

David: When was the first time that you saw something that appeared to be extraterrestrial hardware or just unusual technology?

Pete: That was about when I was about 22, 23.

David: Okay.

Pete: And what I was asked to do was to say, "This seems to be a control panel. Is it a control panel? If it is a control panel, what does it do in this vehicle that it's sitting in?"

David: Were you in some kind of military base?

Pete: Well, I would guess so because it had a number of electric fences and guards and radar and all that kind of stuff.

David: Okay.

Pete: I think they call it Area 51, but I don't know that it was 51. It might have been 52, but I don't know.

David: Okay. So if you were born in 1940, and you're 22 years old, this is now 1962, right?

Pete: Yes. I was, yeah, 22 years old.

David: How did you see extraterrestrial hardware? What happens next?

Pete: I come up an elevator and get off the elevator. And this hangar has got in a big circle set out wreckage like you would see if they were investigating a crash of some kind.

David: Okay. Wow!

Pete: You know, the whole idea is to wrap it all back up into what it was. Say, “Well that came from over here.” It's like putting a big jigsaw puzzle together.

David: Right.

Pete: So I was taken to what was in the center, which they said, “This is very probably the control panel.” And it was set so that obviously a person that had appendages would sit like this [**Pete** lays his hands and arms out in front of him on the table].

They obviously had three fingers, because there were grooves for these to fit in, things that fit in. Thing that held the hand down.

So it was still something that anti-gravity wasn't perfect for because they were holding it. The anti-gravity craft, you can go upside down and you don't even know it.

David: Right.

Pete: So I looked at it, and I said, “Well, okay.”

They said, “So how do we start it? We want to turn it on, but we don't want to . . . If we would build something like that, we'd build it so if somebody found the crash, and they went in and turned it on, they would all be evaporated.

David: Right.

Pete: So we have to think, “Well, these people are smarter than we are, because we can't build anything like this.” I mean, the speed of it was noticed before it hit, evidently.

And as I asked for it, I was given certain things that would be helpful for me in figuring out answers. They didn't want to give . . . They never want to give away anything they don't have to – “need to know” or however you want to call it.

David: Sure.

Pete: So I played with that for about eight months. And so we kind of found out and found that, “Some pieces hit, bounced, and they didn't belong there. They belonged over here.” Because you'd see a break - obviously [it] was two ends of a break.

And it eventually got set around, and eventually it got put together.

David: Was there anything unusual about the material, . . .

Pete: Yes.

David: . . . like it's alloy or its weight?

Pete: Amen.

David: Okay. So it was very lightweight?

Pete: Very lightweight.

David: And unusual metallic alloys?

Pete: Unusual reflection, unusual finish, unusual joinments, whether it was rivets, was it welds, was it different sputtering? You know, there are all kinds of ways to hook things together.

David: You worked on this for eight months, and I'm curious as to whether any results came out of all the study that you were doing. Did you make any progress?

Pete: When they finished the physical reconstruction, it was functional.

David: Really?

Pete: [Nods head 'Yes'.]

David: Did you come into any physical contact with extraterrestrials during this time?

Pete: One.

David: One. Okay.

Pete: And I think it's the one that was left over.

David: Oh, really?

Pete: It was the survivor.

David: And could you tell us a little more about that?

Pete: Other than height and maybe the ratio of the size of the eye to the size of the skull, the size of the skull to the size of the body, other than that, I couldn't tell any difference at all between us.

David: So this looked pretty much like a regular human being?

Pete: Yeah.

David: But you were notified or informed that he had been piloting this craft at some point? They told you that?

Pete: No. Never. No. Hell, they don't tell that kind of information.

David: Okay.

Pete: That's not a . . . I don't need that to know that whatever, except that he was there to give a lot of explanation later. And he came in probably right at the tail end, probably within a month of my debriefing.

David: So let's walk through that for a second. This guy walks into the room, and aren't you curious about how he knows about the technology?

Pete: He walked into the room and was bringing everybody some drinks.

David: Okay.

Pete: So he's somebody there, one of the guys, etc., etc.

David: Okay.

Pete: And then I sat down, and he sat down next to me, and he says, "Can we talk for a bit?"

And I said, "Yeah."

And he says, "You're the guy that's doing the reconstruction of the controls?"

"Yeah."

And figuring them out to start with. And then, "Well, did you notice this? Did you notice that?"

Well, ". . . was the first to notice this," I knew that he was somebody different. Ha, ha. Obviously.

David: Yeah. Ha, ha, ha.

Pete: And I said, "Yeah, I noticed that, but I didn't see any practical thing yet." I wasn't done studying it.

And, I mean, you go piece by piece, because you're working on something that's totally outside of the realm of anything that you've ever heard of or seen or whatever.

David: Yeah. But if the control panel is made for hands with three fingers, then that would imply that this guy wasn't actually one of the pilots but may have just been in a position to know about those people.

Pete: Well, you have to understand there's a huge commerce in craft in the universe.

David: Right.

Pete: So I didn't say he was a guy that built it or it was built for.

David: Right.

Pete: He was somebody who had studied it from the outside knowing some of the underlying technologies.

David: When was the next time that you came into contact with extraterrestrial type of wreckage after this first experience?

Pete: Oh, boy, I would guess 26, about four years later.

David: Okay.

Pete: And then I was called in to do a look-over of another craft that was pretty much whole as best I could tell. It didn't look to me like it was a crash victim.

David: More like it was donated or something.

Pete: Well, I think it was traded. There were people, OTHER people, there.

David: What do you mean by OTHER people?

Pete: They were not from this planet.

David: Okay. How could you tell?

Pete: Ha, ha, ha. Well, if you saw one, you would know, because they're not . . . There are some that, as far as I can tell, are worried that they're progenitors or they're ours.

I mean, I can't tell the difference. And I've seen some of the CAT scans and things of those people, and there's no difference.

David: They're just like us.

Pete: As best I can tell. I mean, they have . . . Like when you look at an Oriental, they have an extra fold in their eye that makes them look like they have slanted eyes.

And these people had a little different look to their eyes. There are a lot of breathing mechanisms that extraterrestrials have.

So you look at a lizard, it's just a hole and a scale on the front of the head somewhere.

David: Right.

Pete: And there are some that breathe through the top of their head and some that breathe down through the thorax.

So the differences, if there are differences, are pretty major.

David: So let's walk through this, because this is something that everybody watching this show, they want to hear the truth. This is some of the experiences you've had that people are going to be the most

interested in because we've been lied to for so long.

Somebody in your position who gets to see this for real, that's an incredible thing.

So first of all, were you briefed in advance? Did you have to read a bunch of briefing documents before you got to meet any extraterrestrials?

Pete: I had to go through training and briefings and everything and then told that, "You're going to see these things, and what you see stays here with you."

David: Oh. So you were thoroughly prepared in advance for what you were going to see. They told you that extraterrestrials existed and this kind of stuff before you ever got to actually see this.

Pete: They told me that I would see very strange people.

David: Huh.

Pete: "Don't make any suppositions." That's what they told me. "Don't make any suppositions. You'll come to your own conclusion. You keep them to yourself."

David: Wow!

Pete: "And then when you leave the base, you leave them here." They say you just . . . and he makes this motion [hand covering his eyes]. "You just wipe that out and don't ever think about it once more or mention it."

David: So you must have been quite nervous or excited, I would think.

Pete: Excited. I was excited.

David: Okay.

Pete: I felt very safe with the people I was with, so.

David: Okay. Now, how unconventional were these first people that you saw?

Pete: I would say from minor to . . . from marginally different, though it's like when you see a person with Down syndrome on a street. You can tell they have Down syndrome from a block away.

David: Right.

Pete: And they're very, very little difference, 3% or 4% difference is all. So yeah, you could look at this person and you could tell by the way they walked, by the way they turned. And that caught your eye.

David: Did their clothing look like ours or was there something different about the clothes?

Pete: Most of it looked like it could have come from a custom shop or something like that, but it wasn't anything like ours. I mean, the buttons were not buttons, and some were magnetic strips, because I was interested in that kind of stuff, anything that I could find that was new and different.

We had different things in the bathroom, different types of stalls.

David: Really?

Pete: Yeah.

David: Ha, ha, ha. Some of them were that different?

Pete: Yeah. On the other hand, one of the things I was going to mention when I was here with you is how alike many of them are.

I mean, the fact that they have four legs. They don't have six legs or five legs or nine legs, and two eyes and the nose and the breathing apparatus in between. Then a mouth, mandible, you know, chin and breathing pipe and ears.

Then there were some later on that came on that were much more insectoid. And so they had . . . And I'd studied grasshoppers and all kinds of things like that when I was younger.

So I knew what their ingestion system looked like and how they sliced off pieces of things or broke them off.

They all pretty much looked to me like they came from . . . I mean, I was thinking about it. I said, "Where would they have come from? What can I see that would tell me that?"

That's how I think about things.

David: Right.

Pete: So I would say, well, I would say they were all from close by because I see differences and sometimes what you'd even call a major difference, but it wasn't really a major difference. It was just a larger, smaller, shorter . . . There are some that have little, tiny, short forearms, for example.

David: Hm.

Pete: They looked like somewhere back in time we all came from the same beginning.

David: Right.

Pete: And then, later on, I got to see ones that were having conversations and doing different things, and they looked really different.

I mean, you could see that like . . . we called them Dracos or Dragons group. And then there's another group that look a lot like insectoids, especially the praying mantis kind of . . . like it may have come from a praying mantis.

David: Right.

Pete: And some speak and some just talk to you in your head. And some do it some other different way. Darned if I know. It's like you know what they're thinking and they know what you're thinking.

David: So when you were brought up to this craft, did you see any extraterrestrials at that time?

Pete: That was my first time seeing an insectoid.

David: Really? So what was . . . That's . . .

Pete: I mean, I noticed that the skin scraped together, and it sounded like fingernail files. It was a chitinous type of . . . or it was an exoskeleton.

David: How did it feel to see such an unconventional-looking being?

Pete: How would it feel to a young person, like, "What the hell is this?" You know, like . . .

David: Yeah.

Pete: For me, because I felt secure with the people I was with, then I felt secure. So it wasn't a fright. I didn't think the thing was going to turn around and eat me.

David: Right.

Pete: And they wouldn't have brought me there for that because they had too much training in me.

David: Right.

Pete: So I didn't have fear from that, but I had wonderment, like "Holy crap!" It looked like it was an insect that was structured – two feet, two legs, two arms, two hands.

Didn't seem to have any wing. If the wings were there, they were well folded. So I didn't see any wing thing to it.

It had . . . It didn't have long antennas, but it had little balls on stubs. [**Pete** brings two fingers about two inches apart close to the left side of his left eyebrow.]

David: This did not look like a human body with an insect head stuck on top.

Pete: It was definitely not a human body. I would say the legs were that big around. [**Pete** makes a circle about 2-1/2 inches in diameter with his thumb and forefinger.]

David: Really?

Pete: Like the eye stalks and stuff. They have two things come out like this. [**Pete** shows his thumbs and forefingers about two inches apart coming out from the side of his forehead about eight to twelve inches.]

They are kind of oval like a flat tube, and then they have the eye on the end of it.

David: Huh.

Pete: But the eye could tilt.

David: Were they compound eyes?

Pete: Yes, they were compound eyes.

David: And how did it communicate?

Pete: It spoke like it had horny plates and things like that that it moved around to make the dissonances and the resonances, stuff like that. It didn't sound like it was coming through a soft-tissue mouth.

It was kind of high, squeaky, raspy.

David: Hm. But it could speak English?

Pete: It spoke English. And there was a definite accent as well, like it would say the same letters we would say. It would say the same letters, and they would sound the same.

There are some species that say the same letters and they sound a little different, like maybe they'd learned Russian first or Sumerian first.

David: And what were you there for? What was the being talking to you about?

You obviously go up into this craft with it.

Pete: Right.

David: Okay.

Pete: Well, being as I had written the manual for the first one, what was being discussed was what's the difference between the controls of this particular device as compared to other devices.

And I only knew them as “other devices”.

David: Okay.

Pete: Now, I did have the knowledge of the first thing that was reconstructed. So I'd seen that. I could see that these controls were very similar, but they were obviously much more modern.

They could have been modern by 400 years. I mean, they were . . . The control did the same thing, but it did it in a whole, totally different way.

David: All right. Well, that's all the time we have for in this particular episode. This has been very fascinating. As always, it's corroborating a lot of things we've heard from others.

So, **Pete**, I want to thank you for being here, and I want to thank you for watching.



David: Okay. So you mentioned two satellites?

Corey: Yes.

David: Let's talk about that for a second. This is part of what you're calling the lower-levels Secret Space Program?

Corey: Right. And the technology of these satellites, which they're stations. They're space stations. The last I heard, there were two. And they're being serviced on a daily basis by these triangular craft.

David: Obviously cloaked or something.

Corey: No, not necessarily. They have perspective in their favor. If you have a triangular craft, it's at 90,000 feet, flying fast. You're not going to be able to discern what it is.

David: It's almost just like one pixel in human vision.

Corey: Right.

David: Right.

Corey: Right. So we're on the verge of this DIA, NSA program being revealed, and the technology will be maybe 50 years ahead of what we have right now. It's barely more advanced than the International Space Station.

David: What are we looking at? You say a satellite. People could think of a rolling tin can with some solar panels on it. That doesn't seem to be what you're talking about.

Corey: No, no. They have manned satellites where they'll switch out crews. Two, three people will be on some of these satellites, but they also have larger space stations, circular space stations.

David: Circular.

Corey: Yeah. But that's a part of what I've been calling the Lower Level Military-Intelligence Program.

David: So what would be the next step? Let's say that you are proven correct, and they announce that there are International Space Station-type things but bigger and a little more advanced, and they announced that flying triangles exist.

Where does that get us? I mean . . .

Corey: Well, that would get us just a little bit into the Partial Disclosure timeline.

David: Okay.

Corey: That is what these groups are working for. They want a Partial Disclosure, that this type of information to come out, no information about aliens in the beginning, and then slowly give us chunks.

If you remember back . . . Was it around 1980 when we first found out about the Stealth Bomber?

David: Right.

Corey: Everybody's, "Oh, that's real cool." And then it became old news very quickly.

David: Right.

Corey: They're expecting the same thing to happen with this Lower-Level Secret Space Program.

David: Do you have any idea of what some of the increments might be after we become comfortable with the idea of these circular satellites and triangular craft servicing them and visiting them?

Corey: I really don't. I know there are a lot of different plans that are being negotiated. Pretty much the Earth Alliance and these secret Earth syndicates have come together and agreed on something, and that something being humanity cannot take a Full Disclosure event.

It would be chaos, and they're right. It will be.

A Full Disclosure event is not going to be a “Kumbaya moment” where everyone holds hands and we're all excited. It's going to be very disturbing, upsetting, and it's going to be a process that us as humanity, we're going to have to work through.

David: If we had the data dumps that you had mentioned before that had been prepared, would those data dumps involve a Full Disclosure if they did happen?

Corey: Yes. Yes. The data dumps are the full data.

And they've now decided, because of the different kill switch for the Internet, ways to bring down electrical grids to keep the information from getting out until they remove it from the system, they have decided that they're not going to do an all-in-one data dump, document dump.

They're going to do it in spurts, and most likely, it's going to be a tit-for-tat kind of data dump release – the Alliance releasing information about the Cabal and themselves, but mostly looking negative about the Cabal.

And the Cabal's going to say, “Hey, wait a minute. We weren't the only ones with dirty hands. Look what this so-called Alliance has been doing the whole time.”

David: So in a life after Disclosure, one of the things that probably will happen based on what you just said is some sort of understanding on a mass level that there was an organized cult running world politics. Do you think that's in the cards as part of the Partial Disclosure?

Corey: No.

David: No?

Corey: No, not as I've heard it described. They're going to try to keep all of the worst stuff hidden, you know, the crimes against humanity, all of the things that they've done here on Earth to people to keep the secret.

That kind of stuff, they're not going to want in public for a while.

David: When we get to the point that extraterrestrials start to become involved in this, how do you see that changing our society?

Like for example, you've talked about Ambassador Mica in some of our earlier updates, and he's describing what happened to his planet. And I know that you've met with him more than since the last time we had updates.

So could you get a little bit more into what the really big picture perspective is like, not just this drip, drip, drip disclosure, but once we really truly have gotten through that horrible, breaking-through experience, and we get the full knowledge of what's going on.

Corey: I think that is going to take a generation or two. I mean, we're so programmed in our different belief systems, the way we've lived and the way we're programmed to worship.

It's going to be very difficult to bring in beings that we would consider higher than us, spiritually, technologically, without us feeling this compunction to give away our sovereignty or to worship them.

David: Right.

Corey: We're going to have to overcome that as well, and that's going to take a while.

David: Or to want to destroy them.

Corey: Or . . . yeah. And Ambassador Mica said that in the beginning, they don't expect us to have open arms towards non-terrestrials.

They expect us to be very leery of any being not from this planet.

David: Now, the Blue Avians, at one point, had told you that the Alliance was not to be attacking any ICC or other faction facilities in our solar system because it was going to be handed over to humanity.

Corey: Right. The entire infrastructure is going to be handed over to humanity once we're gotten through this process, and we'll be a "Star Trek" civilization overnight, because all the infrastructure is already up there.

David: Is there any type of standard boundary around the experiences that people have when they're brought into secret programs and they first come into contact with an extraterrestrial being?

Is there a sort of subset of predictable reactions that they take when they're actually brought into that for the first time?

Corey: Some of the people, they will just drop them into the situation with non-terrestrials, but they usually acclimate them first. You're told, "Yes, it exists." You're shown a picture. You see video. You read more information about them.

And then you'll see one far away, and then you'll see one closer. You know, they acclimate you to the situation if they want you to be an asset.

If you go through this process, you're going to be laying on the floor sucking your thumb for a little while, and you're no use to them.

David: If they just throw you in?

Corey: Right.

David: Are there people that have had psychotic breaks if they get thrown right in?

Corey: Absolutely, yes. That's a fairly common thing to happen when people especially meet some of these very upsetting-looking non-terrestrials.

David: Are there unfamiliar smells that they experience when they meet those beings?

Corey: Very strong ones, yes. Yes, especially the reptilians. Ah, they're horrible! They're horrible. They smell like this musky urine smell, and it is just horrible.

So, yeah, I mean, your eyes, your brain's going to have to deal with what you're seeing, what you're smelling, what you're hearing from them.

David: I remember **Pete** Peterson describing that there's sort of an involuntary vomiting reflex that you have to really fight not to have when you meet an unfamiliar looking, intelligent being.

Corey: Even if they're nicer, benevolent beings, for a while, until you get used to them, you've got this very sick feeling in the pit of your stomach. It's just . . . Something just doesn't . . . It just feels wrong. It doesn't feel right.

You know, they're not supposed to exist, and here you are working beside them. So it takes a while for you to get used to being in their presence.

David: So the other day, I was here, and I watched you taping “Open Minds” with Regina Meredith. But you said something really interesting I'd never heard you say before about the money system.

And you said any planet that has a money system is basically what?

Corey: A controlled planet.

David: Ha, ha.

Corey: Yeah, it's going to be a prison planet. On these planets to where they've had freedom, they've gotten completely away from a Babylonian money magic, because it's only there for control. And if you don't need control, it's useless.

David: Wouldn't you say that a lot of people who might be on the more winning side of the money system would have very strong resistance to the idea that people they think of as lowly or lesser than themselves would now have equal power and equal opportunity as they do?

Corey: Well, I believe, before we get to that point, we're going to have some sort of an economic shift, that we're going to go to a new economic system first that's going to be controlled in the East, that we will have a time where we'll have a jubilee – there will be debt forgiveness.

People will get a certain amount of money depending on how much damage they had suffered from the control system that was set up.

So a lot of people now that enjoy sitting back, calling themselves millionaires or billionaires, when that happens, they may find that 'poosht', all of that has been erased, and they may be on a more equal playing field with everyone else.

David: Wow! Are you saying . . . I think you're saying it, but I want to try to pin you down a little more that this jubilee is part of the plan?

Corey: Yes. Absolutely. Yeah. That's been a part of the negotiation from the very beginning, and we've been hearing about it for years.

You know, "Next month there's going to be a crash and a new system's going to be set up." We've been hearing about it forever. That's been going through negotiations all this time.

David: How would they calculate what your level of damage is from the Cabal? I'm not sure I understand that.

Corey: Well, if you're in a country that has suffered more than other countries, you're going to get more of a boost to try to bring you up to an equal level.

David: Ah.

Corey: One of the things they are describing right now, as a part of this Partial Disclosure and change in the financial system, is to also level the playing field in the monetary system to where every country's money system is going to be valued the same.

That's still in negotiations because a lot of them want it to be based on some sort of a GDP-type situation.

David: Right. So this financial system change . . . Now I've heard about what's called SDR, or Special Drawing Rights, and the idea that currencies get thrown into a "basket", quote, unquote. And the basket represents, like you said, the level of assets that a given country has, and then that weighs in its percentage of how much equity their currency has as part of this global system of trade.

Is that seeming to be the direction that this is going?

Corey: Yes, that's definitely in the negotiations. They basically have come up with an overall, "Okay, this is what we're agreeing to do." And they're starting the process.

But all the fine details, they're still negotiating, you know, deciding exactly what information, when. And that will be negotiated all the way throughout the process, because if they give us a little bit of information and react in this way, they wanted us to react in another way, then they're going to change the way they're seeding the information to us.

The information is going to be delivered in a mind-control kind of a way. That's what they plan on, anyway.

David: And you believe that this is a widespread consensus that's now been reached amongst the Alliance.

Corey: Yes. A lot of them honestly believe that it would be irresponsible to do a Full Disclosure event because humanity just wouldn't be able to handle it. And that is the reason behind why some of these Alliance groups are agreeing with these syndicate groups.

They honestly believe that it would destroy society.

David: How much extraterrestrial involvement is there in this discussion? In other words, are these Alliance groups meeting with certain benevolent or negative ET factions and involving them in the discussion?

Corey: No. What's really happening is like these syndicate groups, they're meeting with non-terrestrial groups.

David: Okay.

Corey: And the Alliance, they're meeting with non-terrestrial groups. But when they come together to do their negotiations, they're all basically proxies of these non-terrestrial groups.

They're there with those groups' agendas in mind in the negotiations.

David: Hm. Now, you've mentioned the possibility of debt forgiveness, but then you've also said that they don't want to disclose any of the occult involvements of this Cabal.

So how would we get to a point that we are acknowledged that we've been screwed and we're given reparations?

Corey: Right now, the majority of humans on this planet are so mind-controlled that they don't even listen to conspiracy theory. So this is something that they see they could do in a feasible way.

David: I don't see how they could tell us that we've been screwed by the Cabal and give us reparation payments without the occult aspects also . . .

Corey: Well, some of the occult stuff will come out.

David: Oh, okay.

Corey: Some of it will, but not all of it. They're going to control what comes out. So it will be nice, bite-sized pieces for the masses.

WHAT TO EXPECT

David: When we're looking at the things that you said to us, I am consistently amazed at how many other insiders were telling me this stuff, totally off the record, before you ever came onto the scene.

What are some of the oppositional elements that are starting to come out against you now as a result of the work that we've done on this show? What is being attempted?

Corey: Well, I was informed that there is a campaign going on that is going to discredit as many SSP whistleblowers as possible so that they will have a better chance of success in doing this Partial Disclosure.

David: Why are they trying to knock down SSP whistleblowers right now?

Corey: What's about to occur is that there is going to be a revelation of a Secret Space Program, and they're going to say it's "THE" Secret Space Program.

And this is the one that's ran by the military-industrial complex. It's controlled by the NSA, DIA and the Air Force.

David: Now, let's say that we actually achieved Full Disclosure at some point. What does the world look like after Full Disclosure? Let's just start talking about that.

Corey: After we've dealt with all the consequences of Full Disclosure?

David: Well, yeah, I guess it's a complex discussion, then, because it's not just what happens after it's over. It's what happens as we start to get it.

Corey: Exactly. Yeah, if we get a Full Disclosure, as I've said before, it's going to affect the psychological and emotional state of everyone on the planet.

It's going to be a rough time, because everyone that has their personal belief systems, they're all going to be challenged immediately.

And then we're going to find out we were lied to, and we're going to wonder, "Are we being lied to now?"

We're going to have a whole process to go through.

David: Now, you yourself have said that you were told you would be shocked by some of the things that would come out, that they'd even surprise you in a Full Disclosure scenario.

Corey: Yeah. If it's going to be something that will surprise me after I've heard about all the slave trade and all these other dark programs, then that's not something I'm looking forward to hearing.

David: Let's just say that we are going to use Mica's people, who you've discussed in previous episodes, as a statement for how we are going to proceed through this.

I guess one question, first of all, is, what does it mean to defeat the Draco exactly? It seems that the MIC has the technology to do that now. We've talked about that. They can shoot down ships and so forth.

Corey: That's not enough.

David: What is really involved in it?

Corey: What you have to defeat is the control mechanism of the Draco or what is controlling the Draco, and that is the artificial intelligence. And when we're able to wipe out artificial intelligence and it can't back itself back up and reinfect people and other beings, then that's the only time that we're really going to be able to say that we have a chance to defeat the Draco.

David: Well, I know that Mica's people seemed to have said there will be training given to certain individuals for the defeat of the Draco. So that doesn't seem to just involve doing an EMP strike on AI.

Corey: In conventional military terms, if you go in and knock out the technology, you still got to go in and physically take the infrastructure. So if we knock out . . . the AI is knocked out, we still have a group of beings that have been serving the AI.

And that's probably going to be a good time to hit them, because they're going to be confused once they've lost the group that they report to.

David: Do you think that these beings can live if the nanites in their bodies short circuit? Are they still biologically functional?

Corey: I believe that, yes, they are still viable –

David: Really?

Corey: - a separate biological entity, yeah.

David: Okay. So what is that going to look like? In terms of whatever Mica's people ended up doing, did you ever get anything specific from him about whether they took out the AI first and then went after the Draco, just like you said?

Corey: Yes. The AI was taken out by solar activity.

David: Really?

Corey: And then the military, which they had a military at that time, rose up and took out the Draco when they were in a confused state.

David: Hm. What could that world look like where we've had an EMP that takes off the AI influence? Are we now seeing Draco flying around in the sky? We know where they are? Are they now trying to overrun the Earth?

Are we seeing them instead of them always hiding like they were before? Is that part of what's going to happen?

Corey: Yes, they would be revealed and also exposed and on the run.

David: Wow! Now, Mica looks like a man of African descent based on the art that you commissioned, more or less . . .



Corey: Sort of, yes.

David: . . . with some maybe Asian features also. Do they have more of a homogeneous look to them on their planet than we do here, because it seems like we have very sharp differences in racial phenotypes?

Corey: They have other races and looks as well . . .

David: Oh, they do?

Corey: . . . to their group. Yes. He mentioned that there was genetic diversity, and they had different species.

David: Different looks, different races.

Corey: Right. Yeah.

David: Interesting. So at this point, we're saying that there is a solar flash that knocks down AI, but you've also described before that the solar flash should have really remarkable effects on human consciousness.

Corey: Yes.

David: So how do those two things fit together? What is the effect on human consciousness that will start at the same time that we begin trying to extricate ourselves from the Draco problem?

Corey: Well, if we didn't have these energetic influences, just getting this Disclosure . . . and after the solar flash alone, would send our consciousness into overdrive, because our consciousness has been suppressed technologically by these negative groups for so long.

But pairing that with these energetic changes that are occurring, we're going to start becoming much . . . it will be much more difficult to pull the wool over our eyes to begin with.

And deception is how they've ruled us all this time. And if they can't deceive us anymore, we are empowered by the truth.

David: You also have said, when we've talked about this consciousness shift, that there is a very upsetting, jarring aspect to it – the sort of “if you throw up, you'll feel better” side of the story.

Let's go back to Mica's people now. Did Mica's people have that experience?

Corey: Yes, it was very rough.

David: Really?

Corey: It was. And they had these other guardians that came in to help them. They called them guardians, but some of them were beings from nearby planets that came in and helped them in the way that they want to help us.

David: Really?

Corey: Yeah. So they received assistance, but they were given a time to process the information before these beings came in and started working amongst them and helping them.

David: So I still am having a little trouble understanding. If the solar flash goes off and people are thrown into some sort of disconcerted state as they adapt to this new consciousness, what does that look like as a planet?

And what does that look like in terms of . . . if the AI has already been taken out when that happens and

now everybody's disconcerted, everybody's having a dark night of the soul, how does that transition into defeating the Draco? I'm not sure I get that.

Corey: The way it was described to me, they are left in complete confusion, complete disarray. They don't have the natural pecking order to contact and find out what they're suppose to be doing because who they report to is going through the same thing they are.

David: So in a consciousness sense, this is almost like them being knocked back to caveman level.

Corey: Well, let's put it this way. If a solar event happened and there were no aliens here, we're so dependent on technology that just imagine the disarray we would be going through.

They're even more dependent on technology. They are controlled by technology. So it's going to be many times worse when that technology is removed.

David: Some people who are watching this show are going to be saying, "Hey, what about amnesty? What about clemency?"

Aren't some of these beings, if they've been totally stripped of everything they had, we find out that they really disliked what they were in and they don't want to be part of it, are we going to have amnesty for those beings or is there going to be like a rehab possibility for them, some sort of imprisonment where they can't do harm but they're able to rehabilitate?

Or is it more like a genocidal cleanout?

Corey: You know, how we handle things is going to put us, as a species and a planet, on one path or another. If we handle things, you know, scorched-Earth, kill everybody that was involved, then that . . . you can't get a positive out of a negative.

If we start off on the wrong foot, then we're probably going to end up on the wrong path. So I'm not an advocate . . .

David: I would strongly disagree, yeah . . .

Corey: I'm not an advocate of clemency at all, but at the same time, we're going to have to find some sort of middle ground. I mean, we're just going to have to.

And that's something we're going to have to do as a people together.

David: I couldn't agree more. I think it's a big, big mistake, in light of everything we know from The Law of One and how the Blue Avians appeared to be the embodiment of that source, it would be a huge mistake for us to act like everyone is equally guilty and everyone should just be murdered.

Corey: It'll be very difficult for us not to react that way, though. As a species, when this information comes out, people are going to be beyond angry.

David: That's very understandable. So the context for our discussion also includes that I just wrote this book, "[The Ascension Mysteries](#)", which for people who are out there saying that you are the only guy saying this, I put an incredible amount of stuff together of other insiders that are all saying the same things that you've been saying.

There's a lot of unknowns about this solar event, and I go into a lot of detail about ancient teachings, which in some cases seem to imply – and this would include the Bible – that whatever this solar flash is, our bodies are changed into something more energetic.

It's a very discontinuous event in which maybe one part of the Earth goes through a cataclysm, but then people on this other layer of time or something do not experience it.

Corey: Well, the way it's been put to me several times is that this shift is a consciousness shift that occurs. And because we have a co-creative consciousness that interacts with matter, the matter, our bodies, will change in a progress afterwards or during.

David: Well, we have statements in the Bible, for example – and I'm going to go to other texts as well – but the Bible says, “flesh and blood cannot inherit the kingdom of God”.

And the Kingdom of God, of course, turns out that it means outer space when you correct the translation of “Elohim” and the translation of “heaven”. Okay? So flesh and blood cannot inherit this new reality that we're going to change into.

You have the Zoroastrians, and they talk about phoscorite, this solar flash. And they say, the wicked are consumed in it as if they're burned in fire, but that they just go through some sort of transmutation.

In the Bible, book of Matthew, it says that people are burned as if . . . you know, that the negative are burned as if they were wheat or weeds tied up into bundles and burned in the barn.

So you say a consciousness shift. Based on those Bible quotes and some other things that I've just been alluding to, how far of a shift are you hearing that this is going to be?

Corey: There are going to be immediate changes, but it's going to be a gradual shift. Mica's people did not all of a sudden start levitating and flying around after this occurred. They had to go through a process, and it occurred just like evolution, but it happened extremely quickly.

David: Well, what I'm also interested in is The Law of One speaks extensively about that there is a separate and habitable fourth-density sphere of Earth that is activated on when this happens, and that we now live on that sphere, and that the third-density sphere becomes no longer habitable for human life.

So it does appear that we're hearing about a very major splitting in which one level of Earth is catastrophic but another level of Earth is activated and can now be lived on. And it's like a hologram of the previous one, but at a higher vibration.

Corey: It could be. I know that with Mica's people, things did not unfold as their ancient teachings had expected exactly, so we may be reading too much into it. It may not mean exactly what we think it does or what we want it to mean.

So there are a lot of unknowns, like you said, about this solar flash and exactly what is going to occur immediately.

His people, they're still flesh and blood. They've been gaining all of these abilities – able to telepathically connect with each other. Their life has extended a little bit, and they expect it to keep progressively extending.

They've gone through this process and are still going through this process, according to what Mica said.

David: Do they have telekinetic abilities starting to form?

Corey: No, no. They can't fly around or move objects with their minds yet, but they have the ability to communicate telepathically, and they have a much deeper understanding of the universe than they had before.

They see concepts from a totally different perspective now.

David: One of the things that we've heard about Ascension is this idea that the veil is dropped, and we now have awareness of our other lifetimes as well as the one that we're in.

I've had it explained to me from the beings themselves that it's as if you have an unbroken continuity in the astral plane in your spiritual form that goes from lifetime to lifetime, and that once you go through this, it's as if you re-access that greater part of yourself.

The limited human mind is now unlimited. You have access to this other part, and you remember being that person.

Corey: Mica stated that they became in closer communion with their higher selves, that right now, we have a hard time connecting with our higher selves, most of us.

David: Sure.

Corey: After this event, they had full access to their higher selves or what they would consider full access after what they had before. So . . .

David: Do you know what that looks like? What does that mean?

Corey: I think it means that there is a veil also between yourself and your higher self.

David: Sure.

Corey: When that is removed and you are able to commune with your higher self, then you're going to have access to all these past life memories and future life memories.

David: Did he ever explicitly tell you that they now have access to parallel lifetimes or other lifetimes?

Corey: No.

David: Okay. But you strongly assume that they do?

Corey: Yeah, I surmised that your higher self is going to have a recollection of who you were in the past. And if you have direct communion with your higher self, it stands to reason to me.

David: How quickly do angelic beings come on the scene, beings that are obviously non-physical, energetic beings that are of a significantly higher level?

Corey: Immediately after the flash occurred, they had guardians come in that were associated with the Sphere Being Alliance, . . .

David: Really?

Corey: . . . that didn't physically interact with them as much as they were there to make sure everything stayed status quo in their star system, to make sure that no other beings came in and took advantage of them going through this process and taking advantage of them in any way.

David: When we have talked about the Super Federation before, you mentioned that as these solar flashes happen, there is sort of an interstellar rescue operation that takes place from these Super Federation groups that are doing their genetic, long-term projects.

Is that part of what you're describing now or is that something different?

Corey: He did not describe anything like that. What he described was these two guardian races basically coming in and I guess being like police that don't interfere.

These groups wanted Mica's people to solve their own problems and fix things on their planet just like they want us to.

David: So what did the tyranny of the Draco look like for them on their planet?

Corey: They were controlled by sort of like a new world order. They didn't have different countries that might war with each other. Everything was controlled by one government on their planet already at that point.

David: And it was similar to what we have here where the government is people like them, but they're controlled by the Draco, . . .

Corey: Yes.

David: . . . which is in turn controlled by AI?

Corey: Yes. And he said, towards the end, it became more overt that the Draco were controlling everything. But I guess it's kind of like people waking up here. We're becoming more awake. That's what occurred on his planet as well.

David: So once we see this flash occur, you're saying that positive beings of some kind come in and make sure that nobody can mess with the process.

Corey: Right.

David: What does that actually look like for the people? How do they trust what's going on? How do they know what this is?

Corey: For the most part, they don't know that there's a guardian race that's come in to oversee their process.

David: Oh.

Corey: Yeah, they're oblivious to it. There will be people in their society that will know about it, kind of like Mica knew what was going on. But for the most part, they don't know.

They're focused on their planet, on their healing and making it through this process.

David: Did Mica's solar system also have these sphere assets come in to help transition it?

Corey: Uh huh. They went through the exact same thing that we're going through.

David: To what degree do they have access to technology compared to where we are now? How much has that changed for them?

Corey: That changed almost overnight. Because like what's expected to occur here, all of the technology they had was basically made inoperable during these solar pulses that occurred.

And they had to start over again. And when they started over again, their technology started becoming more of a consciousness-based technology – much more advanced.

David: Hm. And you're saying that's also expected to happen here?

Corey: Yes. Yes, once all of this technology that we think is modern is removed – we have these different Secret Space Programs that have built out an infrastructure that . . . What's going to happen to this infrastructure during this solar pulse?

So we're going to go from using electronics only to using different types of technology that is consciousness-based. And KaAree's people are doing that with . . . they use crystals and different types of stones that somehow they're able to interface with, and with their consciousness affect change on another object or being.

David: There was a whistleblower associated with the original Disclosure Project where he was tasked with remote viewing, and the job of his group was to create a communications system that was telepathic because there was an anticipation of a great solar event that would make electrical equipment inoperable.

So my point being that we've had other insiders come forward who are also anticipating here that this is going to happen.

Corey: If you noticed, President Obama signed a very interesting executive order.

David: Yeah.

Corey: In this executive order, Obama stated that all of these federal agencies needed to prepare for solar flares or geomagnetic disturbance that would bring down not only the electrical infrastructure, but would affect technology long-term.

So they're building EMP devices to test it in probably a city near you at some point.

David: And most people who watch this show are probably savvy enough to know that there was this thing in the 1800s called the Carrington Event. At the time, we only had telegraph lines, and it melted everything, just from a solar flare.

Corey: Yeah.

David: So this is a very serious concern. What do we do without technology? I mean, do these beings that show up help us once we lose all our toys so that we don't just become totally bereft of the basic necessities for life?

Corey: If we put out a calling, then we'll have beings help us. But during this time period, they fully expect us to be untrusting of other beings coming in bearing gifts after we had just broken the control system of another non-terrestrial group.

David: Did that kind of thing happen with Mica's people as well?

Corey: Uh-huh. Yes.

David: So they went through a period in which much of their entire technological infrastructure was stripped from them?

Corey: Yes. And then everyone was in a bad psychological state. They had to overcome the technical issues and the psychological issues. That's saying a lot. That's a lot to overcome.

And they were able to overcome it and flourish.

David: What are the most likely time windows of when we would expect this solar flash to happen here, because it obviously is going to happen?

Corey: Yes, it's going to happen. When I was in the programs, they had a window of between 2018 and 2023. And most recently, I heard that they had stretched it to 2024.

David: Meaning that that's not when it's going to happen, . . .

Corey: The window.

David: . . . but that's the last of when it could happen.

Corey: That's the window they expect it.

David: 2018 to 2024.

Corey: Right.

David: It does appear, from what you're saying, that this would create some losses of life, especially perhaps in countries that are really, really dependent on the immediate usefulness of their technology to provide basic goods and services.

Corey: Well, think about all the different health technologies that are used to keep people alive. When that technology is gone, yeah, I expect that there's going to be loss of life.

And these new technologies aren't just going to appear. It's not going to be like, "Oh, we lost all of our technology. Oh, here's a zero-point energy device."

That's going to take a while to roll out as well. And that is something that Mica did talk about was that the new technology . . . there was a period of time where they were developing this new technology from . . . they had kind of secret programs as well . . . that there was a lot of physics that their general population didn't know about, just like we don't know about.

David: Did Mica's planet have something akin to a military-industrial complex with a space program?

Corey: Yes.

David: That was secret?

Corey: Yes. They were very militaristic. And within a generation, they were able to get rid of their military altogether.

David: Did the Draco also weaponize that military and try to use it for interstellar combat?

Corey: Yes.

David: Interesting.

Corey: It was mentioned that there was a karmic tie-in. Right now, we have people, human beings, flying alongside the Draco in other star systems or in between star systems, causing problems.

We're going to have to pay for that in some way.

David: Well, I wouldn't necessarily think that people who have never contributed to that would be equally karmically liable as the people who did participate in it.

Corey: No, but as a society, the whole society is receiving the karmic backlash at the same time.

David: Right.

Corey: It's going to affect everyone.

David: Mica's people obviously went through a pretty difficult transition based on how you're describing it. What is the feeling you get when you meet one of them now?

What do they look like? What's their energy?

Corey: Completely beaming with love, and the vibration is completely different than ours. And also, their mind . . . They don't have 10% of their processor dealing with all of this negative stuff, or more of their processor.

Their processor is fully focused on continuing this transition. They are able to focus like this now after these AI and other control mechanisms were removed from their planet.

David: And yet, despite them having this sort of benevolent, beatific, meditative consciousness, you say that they actually like us.

Corey: Oh, yes. They're very excited and look very forward to interacting with us and helping us make this transition.

They do want us to not be fearful of the transition, but they would like us to understand that it's not going to be what many of us think it is going to be – just a flash of light, angels everywhere, and then it's over.

David: And then we suddenly act like Jesus and have all his abilities.

Corey: Right. It's going to be a process.

David: Interesting. All right. Well, this is some of the stuff that I love to hear the most. I hope you've enjoyed it as much as I have.

This is "[Cosmic Disclosure](#)". I'm your host, [David Wilcock](#), and we'll see you next time.

[Cosmic Disclosure: Revealing a Bigger Plan](#)

Season 6, Episode 16

David Wilcock: All right, welcome back to “[Cosmic Disclosure](#)”. I'm your host, **David Wilcock**, and I am here with **Corey Goode**.

And in this episode, we're going to get into some very exciting new updates. I have seen some of the bullet points of what we're going to be talking about, and this is really going to be one of the classics. I'm sure of that.

So **Corey**, welcome back to the show.

Corey Goode: Thank you.

David: When we last left off, you had experienced a knee injury as you were falling out of this MIC craft – Military-Industrial Complex, MIC, what you used to call the Lower-Level Space Program; we're trying to give them a more respectable name.

Take us from there. What happens next after you've had the knee injury?

Corey: Well, since the last time that we spoke and that I released an update, soon after I'd gotten home – it was around October the 26th, early in the morning – I found myself once again in my shorts and T-

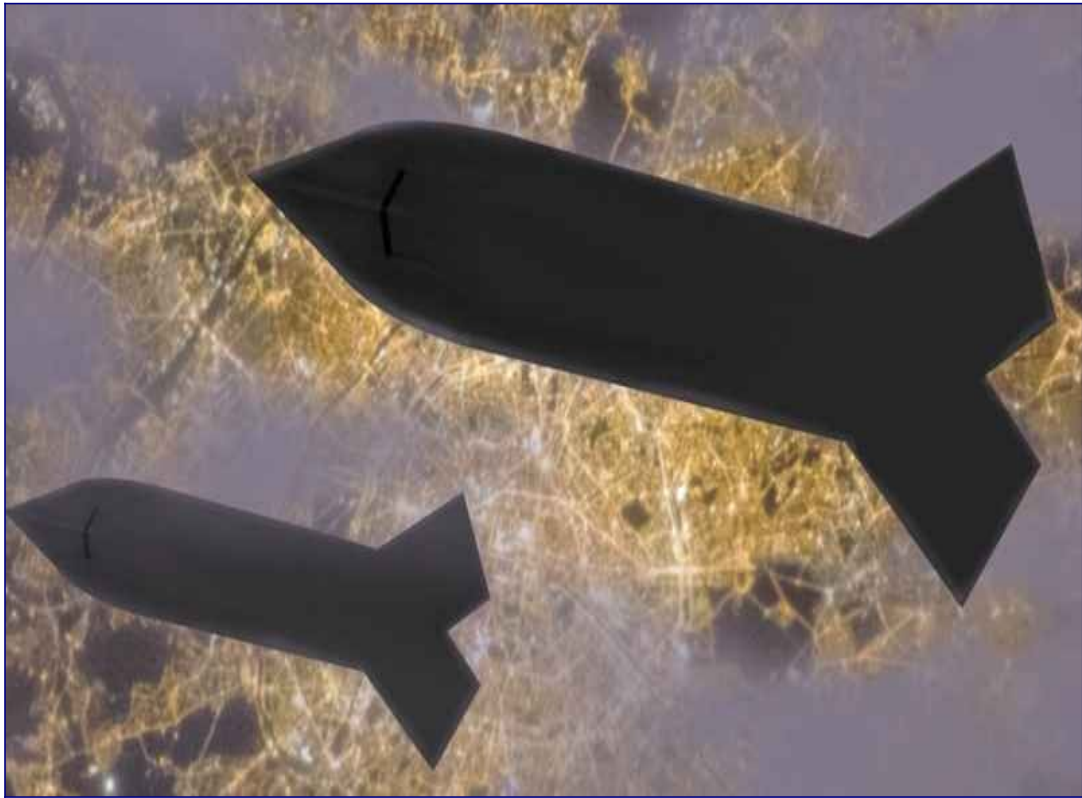
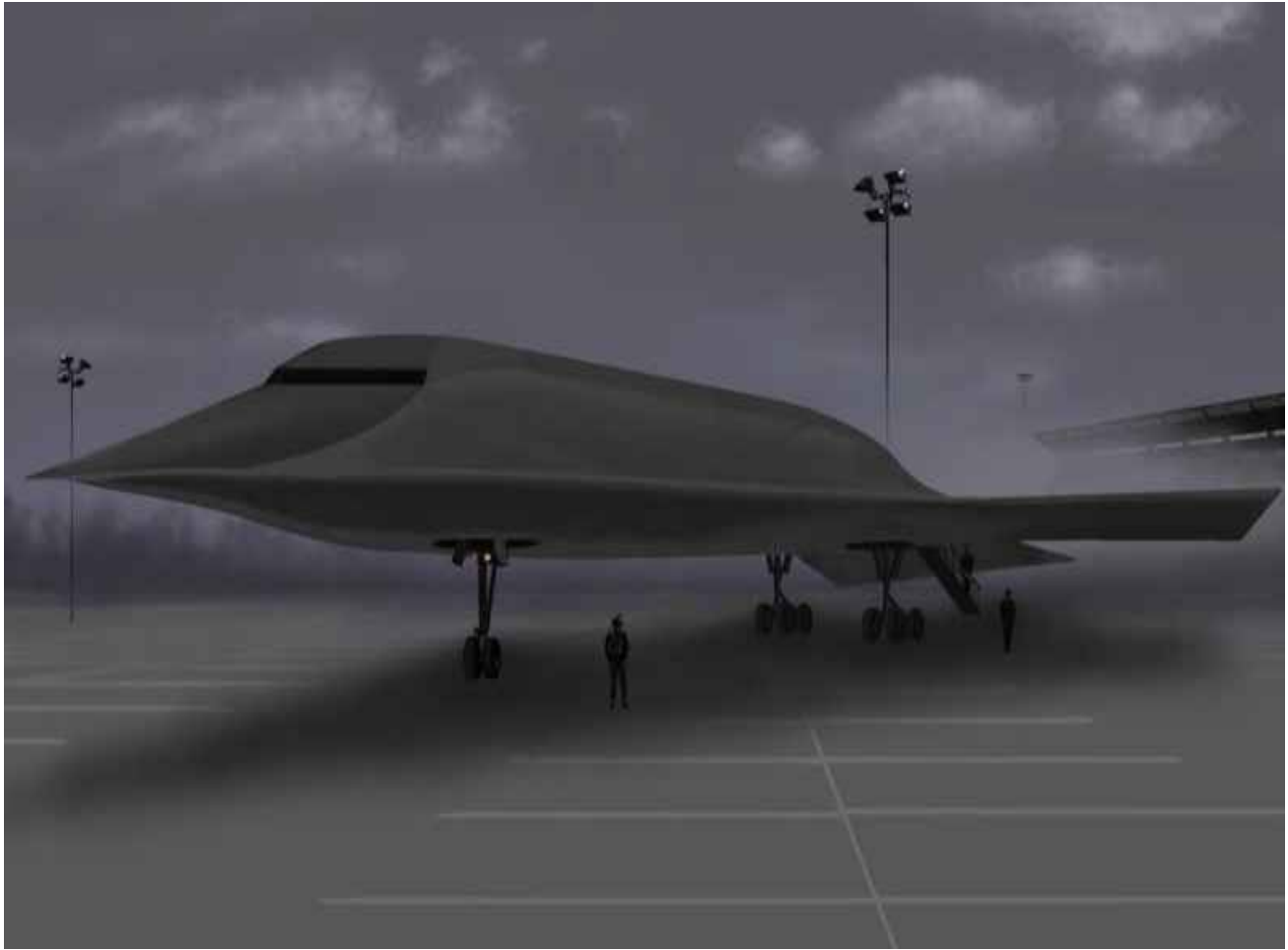

shirt, no shoes, walking in the parking lot behind my house.

I woke up in the middle of walking, and as I was trying to figure out what was going on, I'm still walking. I'm walking towards the same craft as last time, the one that's sort of fish-shaped when you look at it from the top.

David: So this is clearly some kind of anti-gravity craft, . . .

Corey: Yes.

David: . . . not a regular airplane at all?

Corey: Yes.

David: Okay.

Corey: So I see the same two airmen from the last time. And as I was walking up, they immediately asked me if I'm physically able to walk up the ladder.

David: So these were the guys that brought you home and then jogged back the last time?

Corey: Yes, same guys.

David: Okay.

Corey: They walked me up the stairs. I walked through that same storage room, and they walked me into the room where I've been several times before, the one that has the beds that fold out of the wall and chairs.

David: The dreaded interrogation room.

Corey: Right. It looks like a little medical room.

David: Now, you've had some pretty unpleasant experiences in there. So how are you feeling when you find yourself unable to control your own walking, and you walk right up to this craft?

Corey: It's . . . My heart was beating really fast. It was pure anxiety.

David: Sure.



Corey: My heart was beating really fast. I'm breathing heavily. I'm trying not to show it, because you don't want to show any type of weakness to these types of people.

David: Of course.

Corey: But I'm sure they could still see it in my face.

David: Yeah.

Corey: But I was feigning that I was being braver than I really was.

David: Right.

Corey: So they walked me over, sat me down in that chair, buckled me in the harnesses and left.

David: Wow!

Corey: Yeah. So the next thing I know . . .

David: Was there anything different about it, or did it all look the same?

Corey: It all looked the same. The energy was a little bit different. They seemed like they had a little bit friendlier of an energy about them – not as stern.

David: Okay.

Corey: They were still military like.

David: Interesting. So even though they're strapping you into a harness where you've been tortured before, somehow the vibes were better this time based on what you're saying about the energy?

Corey: Yeah, a little bit more laid-back. Not . . . I wouldn't say friendly, but friendlier.

David: Right. You were dealing with this guy who looks kind of like Sigmund Freud or something with the white hair.

Corey: Yeah, white goatee.

David: And he didn't believe that you had been to these places, but you know you've been there. And his scientific test was intended to confirm what he'd heard before, but he wanted his own proof.

Corey: Right. And they had done the same tests before, and he wanted to have control of the evidence all the way to the lab.

David: Okay. So now you're thinking maybe something has come out of this where it was proven right again, and it's changed their attitude. Maybe they realized they're not the only cog in the machine, so to speak.

Corey: Right. Yeah. So I'm sitting there, and as soon as they walk back out the other way back towards the storage room and the tail of the craft, and the older gentleman that we were just talking about, with the white goatee and hair, came briskly walking in from the forward of the craft.

David: Now, did he ever give you any name besides, “Just call me Sir”?

Corey: Sir.

David: Okay.

Corey: He was saying, “You know, I now believe that some of what you're saying is true based on the test results. So apparently, you were in a proximate area that you claimed that you were.”

David: Hm.

Corey: So I didn't know whether to be relieved or not. So I was just sitting there listening.

David: So do you think that maybe . . . I mean, this would obviously be a really big deal for this guy. I mean, we could just call him for a name, because he looks like Freud. We could call him Sigmund. Right?

Corey: Okay.

David: So Sigmund is now confronted with evidence that everything that his whole life has been built around is a lie.

Corey: Yes. And that's one of the things that he mentioned, was that he, in particular . . . They were beginning to feel like they were not at the top of the totem pole intelligence-wise like they'd been led to believe.

David: Right.

Corey: He went on to say, “I was actually stationed at several bases in Antarctica.”

David: He was? Sigmund was?

Corey: He was. Yes. And that got my attention. And he said . . .

David: Several bases?

Corey: Yes. Yes. And he said that under the ice shelf, they had discovered a number of ancient cities, ruined cities – not just one – and that indeed, like I had reported, they had found flash frozen woolly mammoth-type animals, and also these what he called Pre-Adamites.

David: Pre-Adamites?

Corey: Yes. I'm assuming that means before Adam in the Bible.

David: Right.

Corey: And he stated that indeed, they were kind of spindly, had elongated skulls and had strange proportions in their torsos, and that they had obviously not been designed to live in the barometric pressure and the gravity of this planet, and that they had sort of like, I guess, stations where they were studying humanity on different continents.

David: Okay.

Corey: There was some sort of a catastrophe that occurred, and Antarctica flash froze completely.

So he stated that these Pre-Adamites had not had access to their cities, their ancient cities, for over 10,000 years, and that had been a big problem for them. These were the Pre-Adamites that were in these little bases here and there across the world.

After they lost access to their ancient cities, they began to interbreed with the local human population, and then you started having these Adamite-Pre-Adamite hybrids.

And there were all different sorts of them, because they were breeding with different races. There were some of them that had African look, some of them that had Caucasian look, and some of them that had South American looks.

David: Okay.

Corey: He stated that the cities go back as far as when these beings apparently arrived here on Earth 55,000 to 65,000 years ago.

He said from his briefings – this is information coming from him – apparently, they came from another planet in our solar system that was no longer hospitable to life.

David: Did he say where this planet was?

Corey: No. It sounded like either he didn't know or he wasn't going to share it with me.

David: Okay.

Corey: And it was around this time that I began to wonder exactly why he was sharing this with me. And I think he saw the look on my face, and he kind of pulled away.

David: Are you saying that these Pre-Adamites are still here in some form, because we've talked about the Vatican and the mitre hats, that that could hide their elongated skull?

Corey: Yes. In a conversation later on that I have with Gonzales, that comes up.

David: It does appear, then, that these people are living on Earth. Did he tell you whether they live in underground cities, or are some of them actually living on the surface?

Corey: No, I didn't get that detailed of information.

David: Okay.

Corey: I was . . . The only other information that he really gave me was that we humans had discovered these ruins in Antarctica some time ago and had been excavating them, but the Pre-Adamites were not allowed to go down there.

Antarctica was being controlled by the Reptilians.

David: Wow!

Corey: And it was only in recent times that some sort of a deal was brokered to where they allowed these Pre-Adamites to begin to go down there and visit the ancient cities.

David: What did they find in these ruins, exactly?

Corey: Well, they found lots of technology – much of it destroyed, but lots of technology. Just about all the buildings were . . . There were hardly any bricks on top of each other. It was a complete wipe-out. Yet, underground . . .

David: Yet there was still intact technology?

Corey: Right. But underground is where they found more.

David: Oh.

Corey: They found the ancient libraries, and then they found caches of technology.

David: So it must have been fascinating for them if they are now somehow going to be able to gain access to their own ruins.

Corey: Yeah. I mean, it'd been over 10,000 years, and all of their records were there. The bulk of their technology was there.

It would be like sending some of our people to a base on the moon and then having a catastrophe happen on the Earth to where they couldn't come back for supplies.

David: Okay. So in the next bullet point we have, at some point he suddenly stopped talking about this.

Corey: Right. I had a look on my face. I didn't understand why he was telling me all this all of a sudden. It felt . . . It was a little awkward to me. I didn't understand the reasoning.

And as I was thinking that, he saw the look on my face and he kind of stopped. He told me that he was going to use the same technology on me again to change my state of consciousness . . .

David: Oh, boy.

Corey: . . . so that he could see if he could get more information out of me. And I told him, "Listen, I am happy to answer any questions. There is no need for that."

And he ignored me, walked over to that same little stainless steel table, picks up a kind of fat cylinder that has a convex cone at the end that looked like some sort of a antenna.

And he looked down and was messing with it, and I heard that [whirring] sound come up. But just before that, he put in earplugs.

And that's the last thing I remember other than I come to as I'm walking down the tail section of the craft, and my arm is behind me, and one of the guys has my elbow like this [holding tightly] walking me down. And the other guy's in front of me reaching behind and holding my wrist. They were making darn sure that I didn't fall.

David: So this wasn't so much that they were being hostile towards you or restraining you as much as that you were all doped out and they didn't want you to fall?

Corey: They were obviously trying to make sure that what happened last time did not happen this time.

David: Wow!

Corey: So I was really starting to come to as I was coming down the stairs, and I started walking back to my house. I walked through my gate, walked to the back door and opened it, and when I opened it, there was a Blue Orb zigzagging around in my living room.

David: Wow! I'm feeling tingles on my scalp as you're saying this.

Corey: Yeah. I mean, I opened the door and it's just -zit-zit, zit-zit, zit-zit [moving around the room] zigzagging around.

David: Wow!

Corey: And I closed the door behind me and it shot right here [directly in front of **Corey's** chest] and stopped, and I indicated that I was ready. And the next thing I know, I find myself back on the Mayan craft.

David: Okay. Wow!



Corey: This time, I'm standing in the exact same place. And next to the floating stone console that I described last time, Gonzales is sitting there looking. And there are six Mayans in the room this time, including three females.

And I had only seen a female close up once before. And they don't look that much different than the males.

David: Okay. Did they have a topknot hairdo?

Corey: Yeah. Their hair was braided. The topknot hairdo is . . . The artist wasn't able to completely depict . . . Their hair is more up in braids, and then braided into big circles.

David: Ah.

Corey: And then inside the braids, they have the gold filament.

David: Wow! Okay.

Corey: Anyway, Gonzales looks up at me and comes walking up, and in his hand is that same black stone sphere.

David: And what was the purpose of that sphere when you saw it in use last time?

Corey: The last time, he used it to scan me.

David: For memories?

Corey: He walked up to me, and as he walked up, he was raising it. And he was smiling, being very pleasant. And he said, "Please focus your intent on the Magic 8-ball," you know, like an 8-ball from pool, from billiards.

David: Right. Right. He's being funny.

Corey: Right. Right. He's just holding it probably about four or five inches from my forehead, and he's doing this [moving the black sphere back and forth in front of **Corey's** forehead].

And I can tell he's concentrating.

David: For your memories or something? You never really explained.

Corey: Well, I don't know.

David: Okay.

Corey: It could be some sort of a tricorder kind of a device.

David: Okay.

Corey: I don't know. So he scanned for a minute, and then he turned around and he walked back and pushed it against the side of that stone console, and it just [whoosh] went inside of the console.

David: Wow!

Corey: It was gone. And he turned and he glanced at the Mayans that were in the room, and I guess some sort of telepathic thing occurred, and they turned around and walked into the next room. There was a double-wide door into the next room, and the next room looked almost identical to the room we were in with our floating console. And they all gathered around the console.



And Gonzales came up to me and he said, "I want to apologize and give you some explanations about what's been going on." I was ready for that.

David: Apology may not seem like enough at this point. You've been tortured. You've been interrogated.

Corey: He was talking more about the last two incidents.

David: Okay.

Corey: He stated that this had been allowed on purpose. He stated that inside this MIC Secret Space Program, there are a lot of people that are starting to get a little disillusioned.

They're starting to think that there IS more going on than they have been told, . . .

David: Right.

Corey: . . . even though they've been promised that they're top of the totem pole right intel-wise.

David: Right.

Corey: He said that I had to not know about the operation, because they would have been able to figure it out very easily.

David: Sure.

Corey: And I had subconsciously retained all of this telemetry from the Anshar reconnaissance flight, and there was a lot of other information that I had retained subconsciously.

David: I don't exactly know what you mean by telemetry.

Corey: I don't remember what all the information was. But it was giving . . . I had all of these panels popping up. Ka' Aree had to tell me not to get lost in the information, just to look at the scene.

David: So they could kind of index you like a computer and look at what you saw on those panels and read it off of you, basically?

Corey: Yes.

David: Okay. Because right, when you go into that kind of exotic state of consciousness that this technology does, it's similar to like scopolamine, and you can very precisely relive the moment you were in and review whatever is in that moment.

Corey: Right.

David: Okay.

Corey: Gonzales said that basically, they were trying to exploit the state that these MIC SSP people were in, the state of a little bit of disillusion.

David: Right.

Corey: He stated that this was the perfect opportunity to seed the information about the wider Secret Space Programs, all of the other stuff going on, into this group in a clever way.

And by doing so, this could possibly combat, or prevent, this partial disclosure that is about to occur of this actual MIC Secret Space Program.

David: Right, because if they themselves cast doubt upon what they've been told, then they're not going to be able to go forward and know that they're representing the truth. They're going to have doubt.

They're going to have reason to believe, with proof, that you were telling the truth, because your hair tests confirm you were at these locations.

Corey: Right, and the interrogation information. And a very small percentage of this MIC program were just starting to wonder what was really going on.

David: Did you feel any better about all the hellacious things you've been through, knowing that you were taking one for the team and might have been instrumental in stopping partial disclosure?

Corey: Absolutely. If you know there's a purpose to your suffering, then you can file it away better.

David: Absolutely. What's the likelihood of Sigmund being able to percolate this information through the command structure of the MIC Space Program? Does he have enough influence that what he's learned from you is going to saturate through the ranks, or is it so compartmentalized that there will still be lots of groups that don't know anything?

Corey: It's extremely compartmentalized, but from what he had said to me the time before, he is in charge of several programs. So he was pretty high up.

David: Okay. So this definitely could have an effect of starting an avalanche of truth?

Corey: Yes.

David: That's awesome.

Corey: Yes.

David: So did Gonzales have anything else to tell you that was interesting in this meeting?

Corey: We started to discuss the Pre-Adamites, the conversation I'd had with Sigmund. And Gonzales said, indeed, his intelligence confirmed the same thing, that there were two bloodlines among these Pre-Adamites that were considered to be royal.

David: So what do we know about these two bloodlines? Does it correspond to the Americas and Europe, for example?

Corey: Well, the only way he explained it to me is that there were two bloodlines that were both considered royal bloodlines, and they were in competition with each other for resources and control over certain financial systems on our planet.

David: Right.

Corey: We discussed a few of these things, and then the topic changed. A long time ago, I had been told that in certain ancient structures there are cavities and walls to where ancient technology has been stored.

David: Well, if we're looking at the idea that the Cabal has created the Taliban and Al-Qaeda and ISIS as their pop-up proxy armies, when we see things like the Taliban blowing up the ancient Buddhas in Afghanistan, it seems so absolutely unacceptable that they're destroying these ancient monuments.

You think there was more to it than just them being religious fanatics?

Corey: In some cases it's just fanaticism, but in other cases they are looking for something. And in this case, they had completely flattened several extremely important historical sites, ancient Sumerian sites.

And they did find technology in the walls. I don't know what type of technology.

Not only that, but in the process of flattening this certain complex, they found an even more ancient complex underneath it.

And the last time I talked to Gonzales, they were actively excavating as quickly as they could because of the battle that was beginning in Mosul. They had this technology in Mosul, and they were supposed to turn it over to the Pre-Adamites in the Cabal.

And these proxy groups – is exactly what Gonzales called them – had located this technology, and they were refusing to turn it over.

David: That's understandable.

Corey: Well, not to them. This is another Cabal group that was refusing to hand over technology to their bosses, basically.

David: Right.

Corey: So Gonzales said this is a major sign that the Cabal's coalition is weakening big time.

David: So what are the objectives of gaining access to this technology? Are they doing it on behalf of the Pre-Adamites? Is it something the Cabal wants? What are they trying to do here?

Corey: The Pre-Adamites are trying to gather as much of their ancient technology as they can.

So that's one of the reasons why they were also very excited to go back down to their cities in Antarctica and have access to these caches of technology.

David: Do we have any reason to believe that they might be trying to pull their own cosmic false flag, and if they have technology, that they could betray everybody and become their own little warring group?

Corey: I don't know if I'd go that far, but they are definitely preparing for some sort of a conflict or something big.

David: Do you think that they are concerned that they could be outed and publicly blamed and put on trial just as members of the Cabal are, if they in fact have organized the Cabal?

Corey: Absolutely. That's why these elites and these Pre-Adamite groups are freaking out right now.

David: A lot of people are going to be confused at this point regarding the fact that we've talked about AI controlling the Draco, Draco controlling the Cabal. Now we have the Pre-Adamite group being brought in.

So what do you know about the relationship between the Pre-Adamites and the Draco in terms of the control systems of the Cabal?

Corey: I don't think they like each other very much from what I hear. But the Cabal deals with all different types of groups, and a lot of these groups don't get along.

David: But the one thing they all agree on is secrecy?

Corey: Yes.

David: Okay. So Gonzales is describing to you that these artifacts are being located.

Corey: Right.

David: And do we have any knowledge about what is still remaining in other structures? If they've been ruining structures, are they going to try to ruin more structures?

Corey: Well, he did state that some, I guess, black op types of programs or operations, had occurred, that in the dead of the night they had sent operatives in all of these other ancient ruins all over the Earth and they were going in with very advanced sonar-type equipment, checking the walls.

They were checking from space to see if there were any more ancient ruins beneath it.

So yes, they were obviously wanting to find this technology before the Cabal groups did.

Yeah, it was about this part in the conversation that I noticed that that floating console started having all these different colored lights and symbols that were starting to flash.

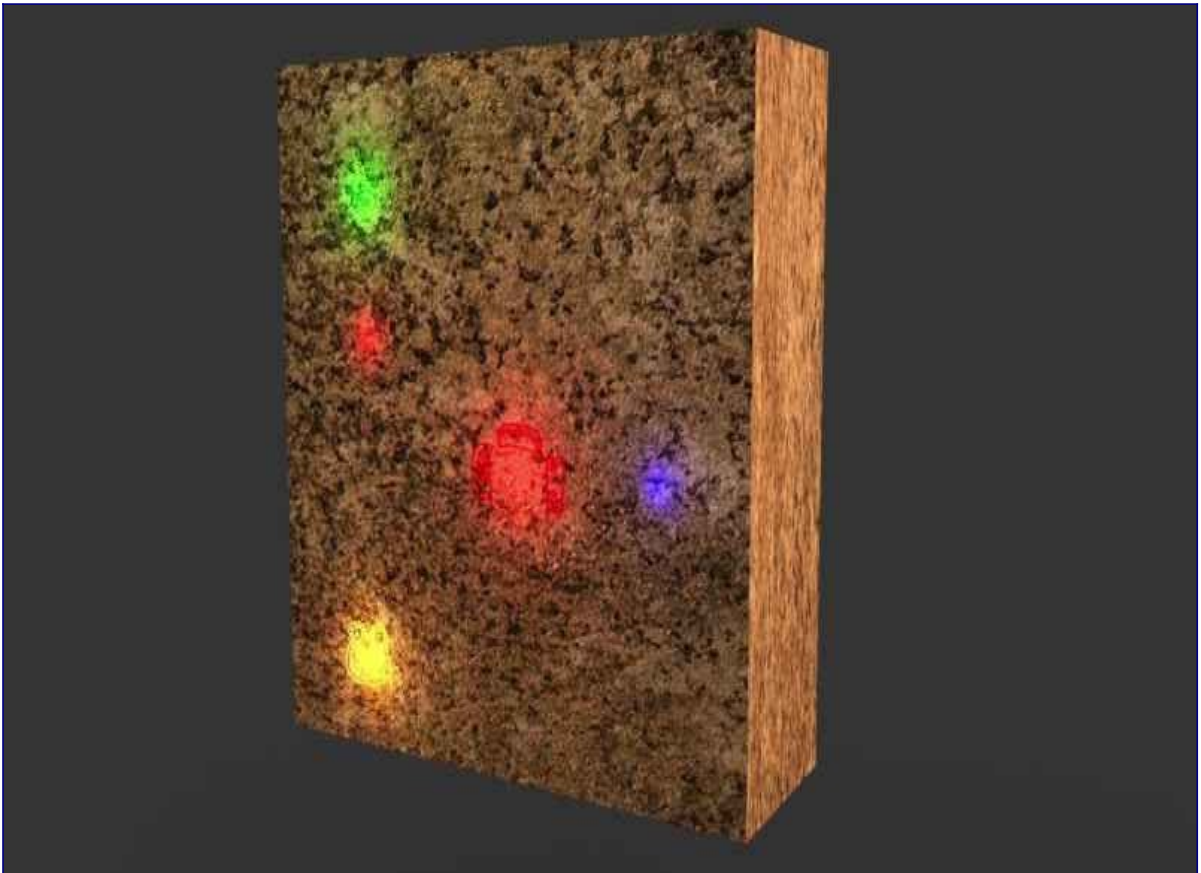

And Gonzales saw me looking, so he turned around and looked and immediately walked over to the console.

And as he was walking to the console, two of the Mayans came in the room. And they began to look at what looked like some sort of a sequence of glyphs that were just doing the same pattern on the stone console.

David: Did the colors vary?

Corey: Yes.

David: What were some of the colors you saw?

Corey: Blue, red, orange, yellow – green even.

David: Okay.

Corey: And Gonzales turned to me, and he kind of had a concerned look on his face again. And he said, “Has your memory improved or gotten worse?”

And I said, “You know, it's actually been getting worse.” I said, “I've been having problems remembering things like my children's birth dates.”

David: Wow!

Corey: And he wrinkled up his forehead and he said, “Well, I'll consult with the Mayan group to see if there's any way we can aid you.”

And then all of a sudden, he got a big smile on his face. I guess he'd seen behind me, a Blue Orb had appeared in the room and zipped from behind me and then was zipping around in front of me and did the normal thing, stopping like right here [about one foot, 30cm, in front of **Corey's** chest].

And he just started . . . he was smiling and started doing this [waving good-bye].

And I indicated I was read, and off I went. And I ended up right back home in the living room where I

had started. I was exhausted. I walked over to the couch, laid, down, and fell asleep until my kids came down.

David: So what's the next thing that happens in our update chronology here?

Corey: About two days later . . . I'm a real early riser. I'd gotten up very early to go down and get some work done in the living room.

And I was sitting on the couch typing away on my laptop when all of a sudden, I got this very strong staticky feel in the room, just all over my . . . The room was full of static electricity.

I knew something was going on. And my attention was pulled over to my right.

The wall where the fireplace is, the outside wall that went out to the backyard, started almost turning like liquid. It was doing like this [**Corey** gives like a waving motion].

The wall was bowing inward into the room, and the bow area was kind of moving around.

David: My insider Daniel, who worked at Montauk, said that when a portal randomly misfired and showed up in the wrong place, like when he was in the cafeteria, it looked exactly like that, and that you'd eventually in some cases see like a grassy field through the middle of it that wasn't really there.

But if you walked through that hole, you would go there.

Corey: Right. I'm looking at this scene and I'm getting nervous.

I have an L-shaped couch in my living room, and then I have the coffee table inside the L, and then I have the wall with the TV on it.

I got up when I saw the wall doing this weird thing, and I moved further away, but I'm still in between the couch and the coffee table.

David: Ha, ha, like that's going to do anything.

Corey: I know, but I was getting like . . . I was whoa. I was getting away. And just like she walked out of water, it was that same Banished woman from my hotel room.

And I was shocked. It threw me off. I freaked out.

David: Wow!

Corey: I was shaking. I was freaked out.

David: Now, can you describe what she looks like?

Corey: Yeah. And she was taller than I had remembered. But when I saw her before, I was laying down on my bed.

She was a good probably three or four inches taller than me.



She was gorgeous. She had thin frail bone structure, beautiful blue eyes, and she was wearing . . .

David: White hair like Ka 'Aree?

Corey: No. Blonde. And then she had white . . . it looked like white twisted cloth that was around . . . She was wearing a very revealing outfit, very little. It was like a wrap that went across her chest, and then also her lower area, there was some sort of a wrap covering her.

David: Okay.

Corey: And she immediately said, “I am Marra. Don't be afraid. I'm not going to hurt you. It's okay.”

She's, you know, calming me down, but it wasn't working. And I saw that she saw that I was nervous. I was scared.



And I saw that that pleased her.

David: Did she have like a sarcastic smile kind of thing?

Corey: She had just a small little smile, and then here smile became very big, and then she just started walking towards me with intent.



And she had taken maybe two or three steps when there was a big brilliant flash of light. And the next thing I know, everything's fuzzy. I'm trying to see again.

And I see I am in a domed room. So I realize that the Anshar had intervened.

David: So you got portaled out from your house along with Marra?

Corey: Yes.

David: Really!

Corey: When I was . . . When I started to be able to see again, I saw two of the Anshar men coming up to Marra, approaching Marra.

And she had a very shocked and freaked out look on her face. Her demeanor completely changed.

David: Wow!

Corey: And they walked up to her. They kind of looked at each other. I guess they were communicating. And they escorted her out of this doorway that had one of the hard light force fields to close the door.

The force field went away and I saw a corridor, and they started walking down the corridor that kind of went and curved away from the door.

David: So was she seriously worried about having been captured?

Corey: Oh, yeah. She was freaking out.

David: Right.

Corey: I was the one shaking like a leaf.

David: Right.

Corey: I was literally shaking. And my heartbeat's real fast. I'm breathing. I'm still suffering from an overdose of adrenaline.

David: Yeah.

Corey: And Ka 'Aree looks at me, and then she walks right up to me and she puts her hand on the side of my face and looks deeply in my eyes, and immediately I start to calm down.

David: So did she tell you what the heck had happened? What was going on? What was this thing?

Corey: I was like, why are the Banished coming back? Why was she coming to see me?

David: Sure.

Corey: And all she said was that her intentions were not honorable, and that was the reason they intervened.

And I said, "Well, what's going to happen to her?"

And I was told that she's going to be put in stasis until the conclusion of events on the surface of the Earth had happened.

David: Wow! Did you get the sense that that wasn't going to take very long, that we're heading toward some rapid conclusion?

Corey: That's the overall feeling that most people in the programs have. It's coming to a head.

David: So it would appear that, given how much you've been warned in the past about authorizing and karma, if something negative like this was allowed to happen to you, there has to be some coherent reasoning in that based on what the Blue Avians have shared with you, what's in The Law of One.

In The Law of One, they're always telling the three people that channeled it, "Guard your alignments carefully. Don't allow any negative thoughts to come into your mind. Try to preserve as much harmony with each other as you can."

Corey: Yeah, and that was . . . And after Marra had been escorted out, we conversed a little bit about Marra. She told me that obviously Marra would not be a problem for me anymore, but that I needed to keep an eye out for some of her group who, after some amount of time, are going to come looking for her.

David: Right.

Corey: At that point, she puts both of her hands on both of my shoulders and is looking directly in my eyes, and she starts to talk to me again.

I get a conversation about how I need to raise my vibration, that some of my anger issues that I've been having with certain people were affecting me in such a way that they had been having problems reaching me in The Construct.

David: Right. And these anger issues might have also given enough of a crack that Marra could get in there.

Corey: Right.

David: Okay.

Corey: So we had that conversation, and when she was done saying what I just said – she had her hands on my shoulder the whole time – she just went [pst], did a quick pat like that [on **Corey's** shoulders] and backed up, and she said, "We're sending you home now."

And there was a big flash, and I was back in the living room.

David: Now, since that happened, have you had any further Blue Avian contacts prior to our taping now?

Corey: Yes, I have. The only thing I can really share is that the cosmic scene that I saw. And when I looked up, the cosmic scene looked basically the same except the spheres are extremely transparent.



They're getting more and more transparent.

The nine metallic spheres that I saw were basically still in the same position.

And the content of the meetings were very similar to the conversation I'd had with Ka 'Aree. They were concerned with the triggered state I had been in.

It was not conducive to the mission at all.



David: That's all the time we have for in this episode of "[Cosmic Disclosure](#)". We're actually way over, but you love it when we do that. We'll see you next time.

I'm [David Wilcock](#) here with **Corey Goode**, and thanks for watching.

[Cosmic Disclosure: Viewer Questions Part 5](#)

Season 6, Episode 17

David Wilcock: All right, welcome back to "[Cosmic Disclosure](#)". I'm your host, [David Wilcock](#). I am here with **Corey Goode**.

What we're going to be doing in this episode is we're going to be reading your questions to **Corey** and getting his real responses. So that's part of how we are forming an interactive community where as a subscriber you actually get to affect the outcome and not just be a passive observer of what we're doing

on the show.

So, **Corey**, welcome to the show.

Corey Goode: Thank you.

David: Let's just get right into this, and we'll start with the questions that we have for you. So I have the list right here.

And the first one is:

“You stated that the MILAB groups targeted wanderers and starseeds. How do they know that a wanderer is a wanderer? Are wanderers and starseeds the same thing? Only answer this if you are willing. Are you a wanderer, and is that why they targeted you?”

So the MILAB groups target wanderers and starseeds. How do they know a wanderer's a wanderer? Are wanderers and starseeds the same thing?

Corey: How do they find these wanderers or starseeds? In the past, they did it through standardized testing. They would have tests that would pop up anomalies.

And if a person popped up a flag that they might possibly be one of these target groups, the people that run the projects will then send in another teacher or counselor that works for the district to come in and give tests eye-to-eye with the kid.

And from that, they are able to extrapolate very easily if they are a soul not of this world.

They use these standardized tests for many different reasons, too. It's not just to find starseeds and wanderers. They're also looking for sociopaths at a young age so that they can bring them in and, you know, mold them.

David: So are you saying that the wanderers are being contacted by their home, native groups, and that the Space Program has the ability to monitor all such contacts that occur on Earth?

Corey: Well, that occurs. A lot of these people are being “abducted” or contacted by their soul groups, and that is a way for them to find people to do further testing on, but they have to do some sort of an interview. And the person doing the interview is going to be some sort of an intuitive empath.

David: Okay. As far as the question of, “Are you a wanderer, and is that why you were contacted?”, what would you answer to that?

Corey: I would say, “Yes”. And I have shared this publicly before. Tear-Eir told me that I and the members of my family are a member of their soul group.

David: When they talk about wanderers, they're talking about ET souls. And when somebody uses a term like “starseed” or “crystal child” or “Indigo child”, these are just different semantic terms for what in The Law of One is only referred to as “wanderers”, but I think it's basically a blanket term, “wanderer”, that applies to everything.

Corey: Okay, that makes more sense because I really couldn't differentiate the two.

David: Sure. All right, let's have another one:

“Are the astronauts on the ISS, International Space Station, aware of SSP program, Secret Space Program, and everything going on with the moon, or are they kept in the dark? Wouldn't the ISS astronauts observe activity going on around them?”

Corey: Yes, they absolutely do observe activity going on around them. For the most part, they're seeing the military, the MIC SSP, the program that is controlled by the NSA, the DIA, Air Force, that kind of thing.

They have a couple of space stations up there that every time they orbit the Earth, they get a look at. So they're seeing these space stations that are about 400 miles to 500 miles out, and then they see the unacknowledged craft that are servicing these space stations. So they are very well aware.

A lot of these astronauts also go through a type of blank-slatting as well.

David: Well, something that you didn't mention that I think is relevant to the question is, haven't there also been a lot of these feeds that get cut from the ISS?

Corey: Absolutely, yeah.

David: So anomalies will show up on the films all the time.

Corey: Right. And that's what we . . .

David: And then it just so happens to turn the camera off.

Corey: Yeah, that's what we get to see. They get to see the whole show.

David: Right. So do you think those people . . . Like when we look at the Apollo astronauts, they're almost all Freemasons?

Everybody that waked on the Moon was a Freemason, and they actually put a Masonic flag on the Moon's surface as well.

Do you think that the people in the ISS are brought into some kind of secret society or are sworn to secrecy in some way, have non-disclosure agreements?

Corey: Well, for the most sensitive projects, they are going to pull people out of the secret societies, because they have already gone through all these tenets, brainwashing.

They've already been tested that they're not going to reveal certain secrets, so they feel that they can count on these people. They're read it.

David: Right.

Corey: There are plenty of astronauts that are not Freemasons that are not going to be privy to the same information.

David: Sure. All right. Let's go for another question here:

“Do Grey aliens, Arcturians and Pleiadians actually exist? I know that the Greys work for the government and are the creations of the Reptilians. But are the Arcturians and Pleiadians peaceful?”

So first of all, I mean, he kind of answers his own question, but do Grey aliens, Pleiadiansm, and Arcturians actually exist? That would be the first question.

Corey: Well, I can most easily put it this way. There are non-terrestrial beings that are in contact with us who claim to be from those locations, yes.

David: Okay.

Corey: We found out over a long period of time, the SSP did, that where most of these beings said they came from was not true. It was some sort of operational security measure they took so we didn't know where they came from.

After that, they started labeling different non-terrestrials similar to like they do stars when they're discovered, like N-T-E, and then like an eight-digit number. And that becomes their designation.

David: Well, if you're inside the Inner Earth civilizations, and you're seeing that they clearly have craft that can fly through rock walls, it wouldn't be that hard for them to travel to some place like the Pleiades or Arcturus, because both of these are very nearby stars. Wouldn't you say that?

Corey: Right. Yeah, and that's how they found out that a lot of these people were not where they came from because they did secret missions to go verify.

David: Oh, really?

Corey: Yeah.

David: Well, but couldn't these people have settlements and outposts at Arcturus and the Pleiades?

Corey: Yeah, absolutely. And in the Pleiades, . . . The Pleiades is a large star system. The Mayan group has outposts there.

There are a lot of . . . The Pleiades has a lot of different groups inhabiting it.

David: Oh, I'm sure.

Corey: So if a being says, "I'm Pleiadian, or, I'm from the Pleiades, that is kind of like us saying, I'm from America. You know, where in America?"

So I hope that answers the question.

David: Well, based on the groups that actually said they were Pleiadians or Arcturians, could you just describe in a little more detail what they're like and what would their characteristics be?

Corey: There were different beings that were coming to us, wanting to make deals with us, were meeting with military and secret society types from the Cabal.

And some of them were coming with what we would consider good intentions to help us with our problems, and some of them were coming to exploit us.

David: Sure.

Corey: That's why . . . And if you have groups like that that come from a same star system, and all three or four of them are claiming to be Pleiadians or whatever the name of that star system happens to be, it becomes very confusing for the Secret Space Program and these global secret syndicates to figure out.

They have to go out and do their due diligence.

David: So if I can simplify what you just said as an answer to the question, there is no one Pleiadian group or Arcturian group identifying as such.

Corey: From my experience in the programs, there were, right, several groups that had made these declarations, and later on we found out that it wasn't true.

David: Okay. Now, the other part of the question I think is worth you commenting on because this person mentioned the idea that Greys are a product of Reptilians as if it was a foregone conclusion. But is that actually true?

Corey: There are some biological androids that are created by different groups, and they get pretty much lumped into the same category.

We have Greys, these programmed life forms we've heard about. Well, so do . . . They have different types out there of programmed lifeforms that resemble the Greys.

So, yes, I would say that some of the beings – I'll say “beings” - that we've described as Greys, have been created by some of these negative groups.

David: What the question didn't cover that I think you've also said is there are also intelligent civilizations that are not androids or programmable that have a Grey physiology.

Corey: Right. Yeah, they have similar characteristics and the human mind. We've heard big head, big eyes, little body: Greys.

And another being comes that looks similar, that's the leap we take.

David: Right. Okay, this is a really interesting question, which I'm sure you can have some fun with:

“What can we do to aid the Sphere Beings in the changes that we wish to see take place on Earth?”

Corey: Very simple. This little spotlight that we have, that we're shining out into space and all around the Earth, looking for answers, looking for ways to affect change, take that spotlight, [**Corey** redirects his hand that was pointing outward toward himself. Whoosh] turn it towards ourselves.

Change begins with each of us as individuals. The message is clear. If we begin to spend our time trying to become more of service-to-others, trying to raise our vibration, then we are literally helping change the Earth one person at a time.

And then after we make these changes, or during while we're making these changes, we're being observed by others.

And they're going to be curious how we've attained this change. So we can share it with our example, or raise curiosity in others when they see the change in you.

The biggest thing that Tear-Eir has pushed home to me is that everything needs to happen in here [ie, inside our self]. All the work that we do out here can be all for nothing if we don't do the inner work and change ourselves.

David: There's been a number of questions on the forum, and we had another list that we compiled before we came up with this one. People are commenting on how much your personality has changed.

It's almost like a much milder version of the classic story "Flowers for Algernon," right? Like, you used to be pretty slow in the way you were talking. Your physical weight, your body, was heavier.

You've undergone a very dramatic transformation, including your apparent IQ level. And people are saying, "Is this **Corey** or did he get replaced by somebody?"

Corey: A clone.

David: How would you tie in what's been happening to you to what you've just said?

Corey: I finally began to practice what I was told to preach and started doing the inner work, and it's been very difficult. It's not been easy.

You know, obviously, yeah, there have been a lot of changes in me. Some of them had to do, you know, I was going through surgery at the time and was on medications. That has some to do with it.

But mostly, it has to do with I started making the inner changes and following the guidance that I was given that I had been telling everyone else to do.

David: How do you think that high vibrational diet affects your consciousness? I mean, it does appear, just based on a kind of back of the envelope calculation, that you've had about a 15-point boost in your IQ since you did that.

Corey: Well, that has to do with the diet a lot, but it also has to do with doing the inner work, you know. If you have all these traumas that you haven't dealt with, they have mass.

The have actual mass, you know, energy mass in your body. When you work on those and you release that mass, then you're releasing a lot of the resources up here [**Corey** points to his head] that are being redirected to deal with the problem that you're not dealing with consciously.

David: Well, that's actually a really good point, and it's mirrored in psychology. Having studied psychology for a degree from a university . . .

Corey: I was a psychology major, too.

David: Yeah, so we do hear in mainstream thought that if someone has repressed memories of trauma, that that does actually take a strong amount of their mental energy to withhold those memories from their consciousness in the subconscious mind.

Corey: It takes a lot of energy, yeah.

David: And then once those memories are freed, all the energy that's diverted into the subconscious mind now becomes accessible to the conscious mind.

Corey: Yeah.

David: So would you say that if someone has traumatic, buried memories, that there is a certain amount of mental energy that's always going to keep that suppressed?

Corey: Absolutely. You know, 10%, 20% of their mental and psychological resources are being used to manage that situation.

David: Interesting. Okay, so now we've got another one here:

“A question on a lighter note. Are you aware of, or do you have, any information on ET civilizations having their own music or other cultural arts?”

Corey: Yes. Part of this will be from the more negative topic of the slave trade. Not only do they trade human beings off, but some of the most treasured works of art that were created here on Earth are now hanging on walls on other planets because of the trades that have been done.

Now, recently, people remember me speaking of Micca and his people.

David: Sure.

Corey: He's the ambassador from one of the closest stars to us in our local star cluster.

David: Right.

Corey: And he said that his people are absolutely enamored with our art and our music. They like many of our different forms of entertainment.

And they, too, have entertainment and art and music on their planet.

David: Well, you would think that if humans are a very common design, at least throughout our galaxy and neighboring galaxies, that almost every planet is going to invent drums, you know, a piece of wood with an animal skin on it.

They're going to invent stringed instruments like guitars. They're going to invent wind instruments like trumpets.

Corey: I just got an interesting mental picture of an ET sitting around a fire playing a mouth harp. Ha, ha.

David: Ha, ha.

Corey: But I see where you're going now.

David: Yeah. All right, cool. Let's have another question:

“What do you know about the Vedic literature?” This the literature coming out of India.

“Is Sanskrit a universal language spoken all over the universe?”

Corey: From what I understand, some sort of pre-Akkadian dialect, ancient pre-Akkadian dialect, is what they call a root language, not only for us on our planet, but out in the cosmos with certain beings.

David: Okay. Now, it's interesting to note that when we have the ancient Vedic scriptures, that it appears there was this Aryan migration, and that roots of Sanskrit occur in languages like Ukrainian, even English. A lot of the European languages actually have strong roots in the primordial Sanskrit.

Corey: Yeah, it's a root language.

David: So do these root languages have some sort of telepathic contact? Like, if you use this language, are you tapping into some sort of data bank of all the other beings that use the language telepathically?

Corey: Well, language is – I've stated before – it's seen as a negative thing for the most part. A lot of these non-terrestrials, that are positive at least, see language, us speaking to communicate, as you and I sitting here trying to manipulate each other into accepting the other person's point of view.

David: Right.

Corey: The way most of them communicate is a very pure type of communication, and that is done in the way that we call telepathically.

David: Right.

Corey: But they do have variations of these root languages out there that these different beings use in certain situations, especially when they're dealing with other cultures, such as like our planet.

Like, if they run across a planet that's early in its development – they don't have a strong language developed – they will give them a root language that will develop out from there.

Some of the eggheads or scientists stated that because there are so many similar root languages on other planets, that it will not be extremely difficult to learn these other languages and communicate with them fairly quickly.

David: Well, if we look at the work of Stan Tenen, he has gone into the Hebrew alphabet and described how each of these so-called fire letters could be modeled with a tetrahedron that has a spiral inside of it – a three-twisted spiral. And then you reflect that light onto a surface and each of the different symmetry spins of the tetrahedron corresponds to one of the letters of the Hebrew alphabet.

Corey: Yeah. Well, language is seen kind of as a stepping stone. You know, when you're an undeveloped species, and you're communicating with grunts and growls to each other, that does not allow you to expand your consciousness and to evolve.

Once you start to have language, you're able to have these more hyper-dimensional kind of concepts to relate information to a like being, if that makes sense.

David: Yeah, that's interesting. Well, and then we also get into Asian culture and the fact that, like Egyptians, they seem to have a pictographic thing where you get these complex characters, especially Chinese, Japanese.

Do you think that would be a different ET group that had its own way of doing things that distributed that to just those areas?

Corey: Yeah. There have been a lot of different non-terrestrials that have been in contact with different races of human on the planet.

David: What might be the reason for why a particular group would want to create complex pictograms like Kanji characters?

Corey: Well, you take one character, and it can communicate a very broad concept to a person. Where if you take one word or one character from our alphabet and showed it to somebody, what is it going to communicate to them?

David: Would you also say that, perhaps, if you look at the language of dreams and how a particular symbol can mean multiple things, and all those interpretations are correct, that some of these more meditative cultures could have language in which a character means multiple things and that's all a meditation on a particular concept cluster?

Corey: Yeah, that could totally be what's going on with some of these.

David: So pictograms could actually be a tool for meditators to help them grasp the interconnectedness of things.

Corey: Right. You know, hieroglyphic, pictogram-type characters, when you see them, your consciousness is pulling more from a hyper-dimensional and multi-dimensional . . . you're pulling more information from one character.

David: Sure. All right, let's have another question here:

“Can you explain the caste system in Ka 'Aree's group? How does their government work? Is it a meritocracy, or do the priestesses handle all of the politics?”

Corey: Interestingly enough, the priestesses do not handle all of the politics. They do have elders, but when it comes to government . . . These are fourth-density beings.

All decisions are happening on a telepathic kind of level.

All of these people are entering The Construct that I've described to you, where Ka 'Aree and I have communicated. All of these people can go in, and they have in this environment somewhat of a hive

mind or group consciousness.

And that's how things happen.

David: So is there a caste system?

Corey: From what I saw, there is a caste system in the sense that they do have a priest caste, but when I spent time out in the city, it was told to me that people rotate and do different things.

Like, sometimes they'll be working in the gardens to help grow food. Sometimes, they'll be working with children, or sometimes they'll be doing . . . you know . . . you know, they're doing many things. They're not pigeonholed.

David: So this is definitely not a caste system in the sense of an undesirable caste that never has any hope of reaching anything beyond what they were born into.

Corey: Right. No queens, drones, worker bees and soldier bees. Yeah, it's not like that.

David: All right. Now, we have another one which gets into the kind of stuff that we try to normally avoid, but we're just going to engage on this. We agreed off camera that we would talk about this because there has been some attacks that have come from Dr. Steven Greer, trying to undermine your credibility, my credibility . . .

Corey: . . . and **Tompkins**.

David: . . . and that of **William Tompkins**. And I just want to point out, before we ask this question, that I have all the greatest respect for Dr. Greer's work. I was at the Disclosure Project event in May 2001.

I met most of the 39 witnesses myself on the ground. And I've also encountered a variety of people who did not speak to Greer, who had never wanted to come forward, and they only trusted me. For whatever reason, that's just the situation I ended up in.

They told me a lot of things. You come along, and then later **Tompkins** came along, and I'm hearing the same stuff, which had never been put online.

When you and I first started talking, there were literally dozens and dozens and dozens of examples of this happening.

So it's kind of embarrassing because somebody like Greer might think that he's got all the information, whereas a lot of people have come forward who didn't talk to him. And with my own discernment, I saw, okay, this guy, **Corey Goode**, actually has the goods. Pun intended.

All right, with that as a disclaimer to start, let's ask the question:

“Dr. Steven Greer of the Disclosure Project and ET Contact Initiative states that ETs and EDs, meaning extradimensionals, must have a very high level of consciousness that would preclude them ever being negative or hostile, and that hostile ETs are nothing more than a propaganda trick. What are your thoughts?”

Corey: Well, those of us that have had experience know that there absolutely are negative ETs. The thought that all of us damn, dirty apes are the only evil beings in the universe is a little insulting.

Duality does not end where our atmosphere ends. A lot of what he said is that we may be setting up people – saying that there are negative ETs – setting them up for some sort of a false flag invasion.

Well, from what I've been told, using technology to project an invasion in our skies is really no longer viable.

What they've moved to is a plan to disclose the lower Secret Space Program – lot of the people he's talking to – and to introduce us to a human-looking non-terrestrial that they'll say has been here helping us for a long period of time.

And then that human-looking non-terrestrial will introduce to us a new sort of esoteric type of religion that they have.

And if we are under the impression that all ETs are positive when they arrive here, we're going to succumb to our programming, drop to our knees, worship them, and, without question, take on a new religion.

So I think that all of us have our own personal belief systems, UFO religions, if you will. And, you know, that's fine. But it's a double-headed coin when it comes to people saying that it's dangerous to say that there are negative ETs, while with what I just said about people thinking that there are only positive ETs, can set up humanity for an even larger type of slavery.

David: Well, I would also want to point out here that this is not simply a question of two public figures who claim to have insider testimony warring it out on an opinion basis and only having opinion as to whether one is judged to be right over the other.

I would say, as somebody who's been on 90 episodes of "Ancient Aliens" on History Channel, that we have a lot of academic research from so many ancient cultures where it's very clear that they were contacted by extraterrestrials.

And the overwhelming majority of those cultures report negative beings and positive beings warring in their skies, warring with each other on the ground, trying to control people on the ground.

So this is an academic discussion. There is no evidence in the academic literature from all these ancient civilizations that we have voluminous records of, of only one good group contacting.

There always seems to be a war between good ETs and bad ETs in all these ancient traditions.

Why do you think that is?

Corey: Because duality is throughout the cosmos. You know, you have these negative beings that are very destructive to consciousness. And then you have these positive beings that are trying to, I guess, put their thumb on the scales in a non-interventionist way, to help us expand our consciousness.

David: Sure. What about this idea that, "Well, if you're going to develop space travel and anti-gravity and portal travel, you have to be some kind of divine being?"

Corey: Well, I've met a lot of our Secret Space Program people that have these abilities, and there's nothing divine about them.

David: Right. All right, let's have another question. We still have some time here:

“Are there other civilizations in other star systems that face similar disclosure issues to our own human civilization, as in, their civilization is, or was, withholding information on technology, history and the existence of other beings out there besides their own native population?”

Corey: Absolutely. Ambassador Micca's people, they were in a very similar situation as we are. They had the Reptilians controlling their planet in much the same way that ours is.

So they overcame this control system and have gone through what we're going to go through – a post-Disclosure acclamation and then a consciousness renaissance.

So that is what we have in store for us, and, yes, other planets in our star system have gone through the same thing or are going through it right now.

David: Well, and would you also argue, based on how well The Law of One correlates, the prime directive seems to be pretty consistent, right?

So a given planet is going to be kept in its little petri dish so they can develop their own culture, their own customs, their own languages, up to a point. And only after that point are they welcomed into this greater galactic community?

Corey: Absolutely. Yes, we have to earn our place in the wider galactic community. Just having Disclosure is not going to do it.

You know, we have to . . . A lot of these beings legitimately are afraid of us, because we're a mess.

A lot of them want to come and aid us in the post-Disclosure process, to aid us in navigating into this big consciousness boom that they have had.

David: Sure. All right, let's have another one:

“Off-world sources, speaking through a channel . . . “, and one of these, of course, is The Law of One – we've discussed that - “have indicated that the SSPs have environmental rehabilitation technology to

correct our current problems. Have you had any exposure to this? Would it be too deeply classified to obtain this through any Freedom of Information Act requests?”

Corey: Well, in order for you to put in a FOIA request, it has to be an acknowledged program. If it's unacknowledged, it doesn't exist. So, you're not going to find . . . I mean, if you put in a FOIA request, they're going to say, “No such program.”

David: Right.

Corey: Right. Yes, I was familiar with a lot of the technologies they have that – I can't remember how they work – ionizing certain radiations in our environment and making them inert.

They have ways of cleaning the ocean.

And, of course, we have the zero-point energy technologies that will stop the future pollution of the planet.

Yeah, if these technologies would be released, we could change our planet in a matter of just a few years.

David: So you're familiar with there being radiation-alleviating technologies?

Corey: Yes. Yeah, they can easily make radioactive material inert.

David: Well, that's a very positive message for us to end on.

We'll see you next time right here on “[Cosmic Disclosure](#)”. It's really great to hear that. I'm your host, [David Wilcock](#), here with **Corey Goode**. And we thank you for watching here on Gaia.

[Cosmic Disclosure: Lifting the Military Industrial Curtain with Heather Sartain](#)

Season 7, Episode 1

David Wilcock: Okay, welcome to “[Cosmic Disclosure](#)”. I'm your host, [David Wilcock](#), and we are here with **Corey Goode**. And we have a special insider for you, someone who has bravely come

forward and is bringing us a lot of interesting corroborating information. Her name is **Heather Sartain**.

So, **Heather**, welcome to the show.

Heather Sartain: Thank you.

David: All right. And **Corey**, welcome back, buddy.

Corey Goode: Thank you.

David: So, **Heather**, let's just hit the ground running here. Since the viewer might not know anything about you, I'll just say that you came up to me at a conference and told me that your father worked for Lockheed Martin.

Heather: That's correct.



David: And that there was a lot of very interesting stuff that he said that fit very nicely with what I've already been talking about.

Heather: Yes, that's true.

David: Okay, so could you just briefly tell us a little about yourself now. I know that you're a college professor, but what is your specialty in your work as a college professor?

Heather: I teach part time at a local university, and I teach geology and astronomy and physics courses. My background is in physics and geology.

David: Okay. So **Heather**, I wanted to start out by explaining that you handed me some very interesting documentation here, the first one being your father's Texas driver's license.



Heather: Yes.

David: And so we see that his name was Edward. It's very clearly real. It says it expires on January 27, 2017. And when did he pass away?

Heather: In July of 2013.

David: July 2013. And the next thing that I have here is, it says, "Lockheed Martin Corporation Master Retirement Trust". It's a check made out to your mother for \$2,103.75.

BEATRICE SARTAIN
1745 DOLPHIN DR
SEABROOK TX 77586

ACCOUNT ID LMC - LM092B
PLAN NAME LOCKHEED MARTIN CORP MASTER RETIREMENT TRUST

PAYEE INFORMATION			
PAYMENT DATE	CHECK NO.	PAYEE SOC. SEC. NO.	NET PAYMENT
Oct 27, 2014	880315437	***-**-****	2,103.75
PAYMENT DETAIL			
PAYMENT SOURCES	Current	DEDUCTIONS	Current
PENRETRO	2,103.75		
GROSS PAYMENT	2,103.75	TOTAL DEDUCTIONS	

And it says, "Lockheed Martin" right on here. And this is his retirement or pension or something?

Heather: Yeah, she receives half of his retirement after he's passed on.

David: Okay. So I just wanted to bring that up to confirm to you watching this that a lot of UFO researchers they really want to see the documentation. And you've been able to provide us with proof that your father did work at Lockheed Martin.

Heather: Yes.

David: You grew up with your father having been in the Air Force, you said, originally?

Heather: Yeah, he was in the Air Force first of all, and then later he worked for NASA through different contractors.

David: Okay.

Heather: And he retired from Lockheed. And he was an aerospace engineer, a senior aerospace engineer for 37 years, working on top secret projects for NASA, as well as Space Shuttle mission and all the way back to Skylab and Apollo missions.

So his career covers several decades.

David: So, **Corey**, I remember that when you were brought up to the LOC, and you had the NASA hat on, they told you, "Take off that ridiculous cover".

Corey: Right.

David: Does NASA have any inside knowledge at all? Or are they just a civilian space agency?

Corey: There are individuals inside of NASA that have closer to the full scope of information, but most of them that have been briefed or know about a Secret Space Program, only know about the one the Military-Industrial Complex has created.

The last I heard, it was two space stations and a number of triangular craft that service them.



David: Okay. **Heather,** getting back to what was going on here, when was the first time that your father said something to you that was out-of-the-box? And what did he say?

Heather: He had referenced a UFO encounter that my mom and my sister had in 1966. And this is pretty close to Johnson Space Center where they lived and where I grew up. And that was several years before I was born. And they were talking about it, and he was talking about the different alien groups that he was aware of.

And about the age of 12, 13, I began to ask questions, you know, “What are you talking about? I thought 'aliens' was a story.

“This UFO that mom saw, is that for real, or was it something that's like military?”

And he said, “No, it's real.” And he mentioned the type of aliens that they saw moving inside the craft, so they were pretty close proximity. [It] happened to be over the Gulf of Mexico, the bay area where the Johnson Space Center is located.

And there was no sound in this encounter that . . .

David: What was the shape of the craft?

Heather: A disk.

David: Okay.

Heather: It's like having two plates, one on top of the other, so that it's kind of a flattened disk appearance, metallic.

She said it had blue, glowing lights all the way around it. And it wasn't like lights you would see here normally, a special technology.

Corey: And it was close enough that she could see people inside?

Heather: Yeah, my sister was six years old. She still remembers what she saw. They could see beings, at least three, moving around inside the craft. And they weren't very large. She said they were like the size of children.

David: Right.

Heather: And so that's when I heard my dad telling her, "You know, those are the Greys. They're robots. They're programmed by a higher intelligence, an older civilization. They come in and out of our atmosphere quite often. They're actually here all the time."

David: Wow!

Heather: And he talked about different groups that are here on this planet, living among us, and they've been doing so since ancient times, actually, not just in recent times, but ancient times.

David: Well, hold on one second. **Corey**, as far as the idea of Greys being robots, does that line up with what you've heard?

Corey: Yes. There are, as we've discussed, a number of different types of beings that have been thrown under the Grey umbrella.

There are the programmed lifeforms that the military uses when they abduct people. And then there are also a group of Greys that were somewhat biologically and technically created by a group that is controlled by artificial intelligence, an ancient group.

David: Okay. When she gave a description of the craft, does that line up with anything that you are familiar with?

Corey: Yeah, that's a pretty classic UFO for that time period.

David: Okay.

Heather: She described it as being the size of a typical 10-by-10, 10-by-12 living room. So that's about all the space you would have inside the craft.

David: Okay.

Heather: Yeah.

David: It must have been overwhelming for you as a child to have seen movies like “Close Encounters” or “ET”, and then to be finding out, wait a minute, this is not just some fiction.

I mean, what you've already described is a lot of information to hear as a child or as a young adult.

Heather: Yeah, well, I know that what my mother and sister witnessed was pretty incredible. And for my dad to talk nonchalantly like, “Oh, yeah, those are the Greys.”

I later on became curious, well, why is he so comfortable with this? He doesn't speak as if it's a joke.

My dad had a very serious personality, very dry sense of humor, a very technical person. Most aerospace engineers are very technical and serious-minded people.

And as I got older, I began to ask questions about the different alien groups that he would mention from time to time, either with his peers, a couple of friends he used to work with – I'd hear things in their conversations – or when he was talking to my mother.

David: Okay, let's just pause for a second there, and I want to get into your father's friends. We had talked off camera about that sometimes they would come to the house?

Heather: Yes.

David: So could you just set that up for us a little bit and what was interesting about that from your perspective?

Heather: They were also aerospace engineers working for Lockheed, and they would come over, and they would have private conversations in our home.

These were things they talked about away from work, but they would share amongst each other. And these were things they were learning from the government.

They all had military backgrounds. And these are things that they would discuss because they're piecing parts together of things they've been exposed to.

So they would talk about metaphysical things, energy, how it can be manipulated, how the population could actually change the rotation of this planet mentally. You can change the atmospheric conditions.

And they would talk about different types of technology that the government's working on that is sort of a reverse-engineering technique based on crashed UFOs that have been recovered and reversed engineering has taken place.

Now, I can't attest to if they were working on this reverse engineering, but I know that they understood it. And they had knowledge of it from work.

David: All right. Well, . . .

Heather: These guys worked under top secret.

David: You said some bombshell stuff, though, and I don't want to make people drink off a firehouse, so let's go back to that.

And actually, first of all, just to set this up, **Corey**, what is your . . . I mean, we're talking about Lockheed like everybody knows what that is. So what is your knowledge of Lockheed and their role in what you were doing?

Corey: Well, Lockheed, of course, is a contractor for the government. They do a lot of research and development.

So a lot of what they develop goes into the Military-Industrial Complex Secret Space Program.

David: Oh. What specific types of technology are you aware of that Lockheed Martin is making for the Military-Industrial Complex?

Corey: Well, I don't know the scope of how much they designed and created this technology, but I know they were heavily involved in the creation of these torsion field engines, as well as their power plants, which in the beginning were your normal, run-of-the-mill nuclear reactors.

Then, later on, they moved to thorium reactors. And then after that, they moved to using this zero-point energy technology.

The reactor would build up electricity in these giant capacitors, and then the capacitors would provide the energy where they were needed for the engine or other devices.

David: So, **Heather**, I wanted to . . . Now that we've kind of set up what Lockheed is, and, **Corey**, you're saying that they are very involved in the Secret Space Program.

Corey: Yes.

David: Okay. So you mentioned this idea of overhearing your father and two other insiders, I guess, saying that our consciousness changes the rotation of the Earth?

Heather: Definitely.

David: What exactly . . . Could you be a little more specific on that?

Heather: Definitely.

David: Because that's a pretty shocking thing for people to hear. That's very outside the box.

Heather: If everyone on the planet were to be, say, on the same continent . . . The closer proximity you are, the more effective the electromagnetic spectrum works.

And through certain types . . .

David: I don't really understand that, though. The closer . . . So you're saying if all our population was on one planet . . .

Heather: No, on one continent.

David: On one continent. There would be some electromagnetic effect?

Heather: There would be this electromagnetic change, and it would actually change the rotation of the Earth just by the human thought process.

Corey: The proximity of all the minds together.

Heather: Uh hm. Yes.

David: They were saying this based on speculation or based on research, or how did they come to this idea?

Heather: I would say that this is based on stuff that they already know, and this is stuff that they're concluding, or stuff that they know as fact.

David: Well, let me ask you this, **Heather**. In a lot of the research that I have done, when I was working on my first book, "Source Field Investigations", we have some pretty remarkable information showing that what they call LOD, or Length of Day, meaning the Earth's rotation, does undergo modifications based on solar activity.

So you might have the sun give off a burst of energy, and it will either quicken or slow the Earth's rotational speed in a way that is subtle but measurable.

Did they have any reason to understand why the Earth's rotation could be affected by human beings? You say it has to do with electromagnetic energy somehow?

Heather: Yes. Inside every person, you have control over electromagnetic fields. You have your own inside the pineal gland, and you also have the interferences of other types of electromagnetic energy. So that includes all of the light spectrum.

We have really short wavelengths of energy coming in from cosmic radiation all the time. And we also have very slow wave or longer wavelengths of, like, radio waves, for instance. Like AM radio waves can be three meters in length.

David: Right.

Heather: And our pineal gland actually produces short wavelength radiation. And it's not harmful to us or animals or anything on this planet. But the closer you are together, the more metaphysically powerful it is.

David: Hm.

Heather: And that doesn't mean that we have to be like crammed inside a tuna can, but it just represents the proximity of the mind and the consciousness working together can affect an entire planet, if not neighboring planetary bodies.

David: And they knew this scientifically?

Heather: Yes.

David: Okay. So, **Corey**, this seems to raise a lot of questions about mass consciousness effects. And what are your feelings about how the Cabal has been aware of this and is using this knowledge?

Corey: Well, I mean, as I've stated many times, the power of our co-creative consciousness, they want to keep us unaware of, because that is THEIR true power.

They manipulate us and our collective consciousness to cause things to happen in real time and in our world.

And their magic, it's not really that true of a magic. It is just manipulating us to make things happen with our co-creative consciousness.

David: **Heather**, did you ever hear anything like that from these conversations?

Heather: Yeah, well, just talking to my father one on one, we would have discussions about things like this.

David: Really?

Heather: And one of the things that we did discuss, and I have noticed over the years, there's a lot of distractions to keep us from being in touch with the power that we have in our DNA and the organ, the pineal gland.

That organ is tremendously important. It has been just very surveyed over in medical science. Students are not learning about it.

David: Right.

Heather: There's a reason for that. When I first started reading about the pineal gland and the power that it holds for us, I asked my dad questions.

David: Oh?

Heather: And I wasn't too surprised that he knew about it, knew exactly what I was talking about. He said, "I'm glad you're reading that, because that's a very important organ that they are going to distract you from."

There's a lot of distractions all the time politically, in the economy, and environmentally.

David: So, **Corey**, did you hear about the pineal gland while you were working in the SSP?

Corey: Yes, definitely. And all . . .

David: I've never heard about it actually generating low-frequency radiation before.

Corey: Anything that emanates from it is going to be radiation.

David: Right.

Corey: It's something radiating from it. And when I was looking at the smart glass pad, we're talking like 30 years ago. So there's a lot of stuff, fine detailed, that . . . I was not into pineal gland stuff, but they did talk about measuring effects from a distance from the pineal gland of different things radiating from that point in the body.

David: What does it do, though? I mean, if we're generating this radiation, so what? What's the difference?

Heather: That organ is really important both spiritually and with the rest of the cosmic space that we live in.

David: Okay.

Heather: It's not just Earth-bound. It's a communication device as well as an awareness device. And without it, there would be a tremendous amount of things that we'd never become aware of.

It is the foundation of consciousness. It's a communicator.

But there are so many things that the pineal gland is purposely exposed to in order to basically pipe down the functionality, if not completely turn off its functionality.

David: I think what you just said, and I want to clarify this, the things that it's being exposed to, you mean things that our Military-Industrial Complex, or Cabal, or whatever we want to call them, are deliberately creating to try to suppress its function?

Heather: Oh, yeah. I have a coworker and a friend who used to work for the water department.

Corey: Fluoride.

Heather: And he told me about how much sodium fluoride he had to add to the system and that over the years that he worked there, and he worked there for I want to say a couple of decades, over that time, they just kept adding more and adding more .

And this is right at home in the Houston area, but it's not just Houston. It's all over the U.S.

David: So let me just add something that I think is relevant here in case you watching this don't already know this.

My research has showed that the interior of the pineal gland is water, but that there are small crystals in there, and that fluoride, because the blood-brain barrier is not in effect for the pineal gland, anything that's in your bloodstream can go in there.

And if there is fluoride in your bloodstream, it attaches to these crystals that are very important to the pineal gland's function.

And ultimately you get this thing looks like a bony lump on an X-ray. It's actually calcified pineal gland.

So did he ever talk about the calcified pineal gland?

Heather: He talked about our government suppressing the pineal gland for a very good reason. And if you ever really wanted to control our type of being in our population, that's the first way to do it. That's the first thing you're going to attack.

And it's not been in recent years. The pineal gland has been under suppression for hundreds of years.

David: Corey, are there any strategies that can be done to fight back against this pineal gland calcification?

Corey: Well, yeah. A lot of people have changed their diets, what type of water they intake, and doing a lot of meditation helps.

But mainly, it comes from taking care of your temple and being very guarded about what goes into it.

David: So distilled water occasionally would help to decalcify?

Corey: Yes, that's what I've heard.

David: Okay. Now, **Heather,** you also mentioned that your father and his buddies said that we could change the atmosphere. What exactly does that mean?

Heather: Well, every molecule, every compound that exists in our atmosphere and the state of a gas – and it doesn't matter if it's a solid, or a liquid, or a gas, but even gases can be connected to the electromagnetic fields that we produce because all electrons in the outer shell are manipulated by these field forces.

And these field forces are waves that travel through and propagate through space and atmosphere.

So human consciousness, or the human electromagnetic field that's produced, can change atmospheric conditions.

We could actually environmentally clean up this planet through our thoughts, . . .

David: Hm.

Heather: . . . because the thoughts is what controls everything we do and how we perceive.

David: Have you ever heard anything like that, **Corey**?

Corey: I hadn't heard it put like that, but what she was talking about that occurs subatomically, I definitely read.

David: So our minds could create a storm? Is that one thing that could happen? Could we create severe weather?

Heather: I would say yes. That's one thing that could happen, but it would take a group effort in order to do so. I wouldn't attribute that to just one person.

David: Why are they so freaked out about this? What's the threat?

Heather: The main thing that the Cabal or our government is trying to do is suppress our awareness. The less we are aware of what we can do, the less we're going to do.

The first step is being aware. The second step is then utilizing what functionalities you do have access to.

Some of the things that have occurred in our government over time besides suppression of the pineal gland is suppression of our DNA. Our population has had upgrades of DNA just based on geological catastrophic events.

My father told me that some of these events are controlled by alien groups.

David: Hm.

Heather: How they manipulate Earth catastrophic events is through the Earth's inner core.

David: Through the inner core.

Heather: Yeah. That's where the . . .

David: Could you be a little more specific?

Heather: The Earth's inner core is responsible for the Earth's magnetic field. That magnetic field is a shield. Right now it's been under depletion for a number of years.

It goes through cycles of becoming very strong to very weak. Some of that has to do with the Earth's parallax, which occurs every 26,000 years. And we're about 4,000 to 5,000 years away from another complete parallax.

David: Hm.

Heather: And that has to do with the Earth's wobble. So that wobble will change, and eventually the North Star that we have today will be a different star.

David: Sure.

Heather: So when these things occur, there are a time window of opportunity to manipulate the planet, and that's when the tectonic plates will move. That's when catastrophic events will take place. That's when human DNA will be changed.

David: So **Corey**, does this line up with anything you've heard? Is the magnetic field in some way a shield that when it's weak it will allow more of this DNA-modifying energy to enter into our planet?

Corey: Yes, and in addition to what she's said, I've also heard that the strength of our field has to do with our core, but also it has to do with the interaction of the, I guess, core in the sun.

Heather: Um. Definitely.

David: Your father is sitting there with his buddies, and was this stuff that you were not supposed to be hearing?

Heather: He didn't think I was listening.

David: Oh. Ha, ha, ha.

Heather: I heard bits and pieces of their conversation. As I got older, him and I would talk, and when he noticed that I was genuinely interested and was following what he was telling me, he told me more.

But there were things that he did not tell me because they were top secret, and he adhered to the instructions he was given at work.

David: Hm. When did you start to get more information about extraterrestrial groups and what types of groups are out there?

Heather: He had mentioned there was a number of groups and that we, meaning our government, has been aware of these groups for a number of years now.

So I asked him what types of groups there were, and he talked about the Pleiadians, of course being from the Pleiades star system. They're very tall and fair beings. They're broad-shouldered. They're very wise. They're a very old civilization.

As far as he knew, they were among the oldest of civilizations in operation. They're very kind. They're only here to do good.

He also talked about Nordics. Nordics are farther away than the Pleiades star system. He said they had no body hair. They were also tall. They were also a good group, and they work on things like the Pleiadians to help raise consciousness, and not just our planet, not just our solar system.

He talked about Reptilians. They're very intelligent. They're also an older civilization. However, their intentions are not good.

David: Right.

Heather: They're very evil.

He talked about two different types of Greys. Both are being controlled by older civilizations, one type being tall, and the typical pictures of the oval face, the small nose, the large eyes.

And actually, he did mention to me before that some of the Greys are controlled by the Pleiadians.

The small Greys that are about three to four feet in height that you would typically see in the craft like my mother and sister witnessed, those are very robotic, very programmable, and those are controlled a lot of times by the Reptilians.

David: Oh. Okay.

Heather: Although other alien groups can take control over these robots because the technology is old.

David: All right. Well, let's take stock of some of that, **Corey**, because we've got a good foundation here.

So the first thing that she mentioned was Pleiadians. And you said they were tall, **Heather**?

Heather: Yes.

David: Could you be a little more specific? Did he ever give . . .

Heather: Seven, eight feet tall.

David: Okay. So have you heard of anything like that?

Corey: I've heard of beings like that, but as I stated before, in the programs they found out that a lot of these beings that we were interacting with that were telling us they were from this or that star system, they were not telling us the truth.

They were doing it for operational security so we didn't know exactly where they did live in case we developed technology and became a problem.

But there are some of these people that get lumped in with the Nordics that are around eight foot tall. A lot of them have blonde to like strawberry blonde kind of hair. And they'll have blue eyes. They're very tall. The men sometimes will have beards.

David: And she also had mentioned Nordics, and you said that they did not have body hair.

Heather: That's what he told me.

David: Okay.

Corey: Right. There are groups out there that are completely without body hair, bald. They're tall, pale. But I'd never heard them referred to as Nordics before.

Heather: Okay.

David: And let's talk now, **Heather**, about Reptilians, because that's something that we've actually gone into quite a bit on this show. So I'd like to . . . When did this subject with your father first come up?

I mean, the television show “V” was out in the early '80s, and so that was obviously an invading alien race that tries to look benevolent, but then they have a Reptilian face under the human face.

Heather: Yeah. When we first talked about the Reptilians, I was 19.

I was going to college, and I was working part time at Space Center Houston. And that's when he really opened up and started to tell me more.

I think he felt that I was at a mature enough age to comprehend it, and he did tell me a few times, “I wouldn't talk about this stuff with your friends. I wouldn't share this information, especially not right now. Just keep it to yourself.” So I did.

David: Right.

Corey: Sounds like stuff I tell my daughter.

David: Yeah. How did this subject with him come up? What was the first . . . How did it start?

Heather: I would hear him say something, say, with my mom, having a conversation. I'm like, “You said something to her about Reptilians. What do you mean by that?”

David: Hm.

Heather: So usually I was asking questions based on something I heard him say.

David: Okay. And what was his response?

Heather: Well, one time he just said, “Oh, they're bad. They're really, really bad. You don't want to encounter one.”

And I don't know if he has, and I don't know that he would ever disclose that, but . . .

David: What was the description that he gave of them?

Heather: Well, they have scales. They're very reptilian-like. They look like us, but they have a body full of scales.

Their eyes are different. They have different-shaped head. They have a little bit larger head than we do. And he said something about the top of their head. They had some type of hard material, almost like a helmet.

Corey: Like a nuptial hump?

Heather: Yeah. Yeah. And he said they controlled some of the small Greys that do the abductions on this planet without our permission.

David: Right.

Heather: A number of people are abducted, not just animals.

David: Did he get into any detail about their color or their appearance in that sense?

Heather: I don't know that we discussed their color.

David: Okay.

Heather: But he said, “Just think of a snake and how a snake skin looks and appears.” That's kind of what they would look or feel like.

David: Was it confusing to you when he first brought this up to try to understand and visualize what he was talking about?

Heather: Yeah. I think I laughed a few times. It sounds a bit ridiculous, especially in 1992.

David: Yeah.

Heather: And that was the first I had heard. And then when the Internet became available, around the time of 1996, 1997, there wasn't a whole lot of information available.

David: That's for sure.

Heather: But as time progressed, I would do some research, library and Internet, just to see what is available, and basically to verify what he has told me before. There wasn't a lot of information.

David: You said the eyes looked different, but you weren't specific. Did he ever tell you how they looked different?

Heather: I think he said they were yellow in appearance or red, not the same colors of our eyes here.

David: That's exactly what **Corey** said before.

Corey: Yeah.

David: Did he talk about vertical-slit pupils?

Heather: Well, he said they were reptilian eyes.

David: Right. Okay. So that lines up very nicely.

Let's profile these beings for a minute. Did he give you any information about where they had originated from or how old they were or anything like that?

Heather: The Reptilians, he said, were an old civilization, but they've had a lot of problems. And he didn't get into a whole lot of detail other than they've moved around. And they have had an enormous amount of evil intentions on not just the Earth, but other groups.

David: Are these ETs all holding hands and signing "Kumbaya" together, or is there some type of battle between them?

Heather: There's definitely a battle. There's a galactic battle that's been going on since time began.

David: So, **Corey**, how well does this correlate with things that you've heard?

Corey: It sounds a lot like what we've discussed.

David: Sure.

Corey: Yeah. For sure.

David: And this idea of the Reptilians having to move around a lot, she didn't get a lot of information, but what is your understanding of why they have to move around?

Corey: They are a transient species of conquest, and they travel from region to region, looking for clusters of star systems that they can exert their influence over.

David: And they keep getting wiped out or beaten?

Corey: Yeah. They've had . . . A lot of people out there, they've been programmed to believe that the Reptilians are all-powerful, they cannot be defeated or killed and all this.

They've been defeated many times, even here on Earth. They've been chased off of Earth many times and come back.

David: So, **Heather**, you mentioned the history of the Reptilians, the Nordics, the Pleiadians. Did you ever get a thing about how old the Greys were? Or are they just something that's created, almost like a commodity?

Heather: The Greys are created as if they were androids made by people. They're robots. They are programmed, although they have a powerful computer-like mind that has biological aspects.

And they can control the crafts that they're in, but there are times they're not very good at it.

David: Really?

Heather: Yeah. There's been times that they don't come into the Earth's atmosphere at the right location, and that's why there's been crashes. Just like a computer that a human programs, it can crash. It can get viruses. It can have issues or things you overlook. It's the same thing with the Greys.

David: One last thing I want to ask you, **Heather**, just before we close out this episode is, some of the stuff that you've said might be terrifying to some of the people that are watching this show.

Did your father ever express that there was a vulnerability of these negative groups? Are they just invincible and all-powerful, or is there a vulnerability there?

Heather: He told me this. They work in large numbers because they have to.

David: Really?

Heather: It takes a lot of say, Reptilians, to get anything done. They work on a very low level of consciousness, very low, intense radiation.

Corey: Like drones, kind of droning around.

Heather: Low vibration.

Corey: Yeah.

Heather: So they have to work in large numbers to accomplish what they want to do.

David: Hm. So how is that a vulnerability?

Heather: Wipe them out to a small number.

David: Ha, ha, ha.

Corey: Yeah, find a way to split them apart.

Heather: Yeah.

David: Divide them . . .

Corey: Divide and conquer.

David: . . . and they don't have the strength when they're separated.

So that's all the time we have for in this episode. I'm [David Wilcock](#) here with **Heather Sartain** and **Corey Goode**. This is "[Cosmic Disclosure](#)", and I thank you for watching.

Cosmic Disclosure: Revealing Hidden Technology with Heather Sartain

Season 7, Episode 2

David Wilcock: All right. Welcome back to “Cosmic Disclosure”. I'm your host, **David Wilcock**.

We're here with **Corey Goode** and our special guest, **Heather Sartain**, whose father worked for Lockheed Martin, a well-known defense contractor, and who decided to tell her some things that he probably shouldn't have, but we're all very glad that he did.

Now, he's talking with his buddies in your house, and you had mentioned in our previous episode that they discussed craft that had been reverse-engineered.

Now, that's a very common thing we hear about in UFOlogy, but I'm interested in starting today on what you heard specifically about this particular subject when you were hearing them talk.

Heather Sartain: The craft that had been recovered in Roswell, New Mexico – and that's not the only place there has been a crash.





That crash occurred in 1947. And there have been other places, especially out in the desert, where craft have been recovered.

The government, the military, has housed them underground at Ellington Air Force Base, as well as at Area 51.

And they have been able to turn on the mechanisms that control the craft, and, of course, there's a lot of very intelligent engineers available to reverse-engineer this technology.

And it's just like if you were to take a cell phone, and you're from another century, and you're a smart person, and you understand how electricity works, perhaps, you can reverse-engineer a cell phone.

David: Did he ever talk to you about some of the hurdles that they had to go through in order to be able to run the craft? Was there anything unusual about the technology?

Heather: The unusual things I heard him tell me about the technology, it's very quiet, it's very powerful. It works off electromagnetic energy.

There's a reason why most of these craft are metallic. That metal is not commonly found here. It's actually a manufactured material, and it's not manufactured here.

So this is manufactured in another planet or solar system by other groups of aliens.

David: Were there unusual alloys in the metal?

Heather: It was a mixture of metals, from what I understand, and they have a high density. Some have lower density. So there's been a number of different craft that have been recovered over the years.

David: Did you ever hear about scandium aluminum or bismuth or any of those elements?

Heather: Oh, it's funny you mention that, because a student of mine just found some bismuth . . .

David: Oh, really?



Heather: . . . and they thought it was a meteor, and they brought some to class.

David: Oh! How about that!

Heather: Yeah, it's very unusual. In fact, I took it to one of the planetary scientists at NASA for analysis, and it's all bismuth. They don't know where this came from. It's a very strange conglomerate of material.

David: So, **Corey**, when she mentions high-density alloys, high-density materials and being built outside our solar system, or at least off-planet, does that conform with some of the things you've heard about the composition of these craft?

Corey: I know that they were exotic alloys, but I don't recall that much of what I was reading about the metallurgy.

Heather: I understand part of it, from what he told me, is for protection when they enter our atmosphere. And they have the ability to enter the atmosphere very quick, so high velocity, and the metal can withstand the frictional forces.

David: And you mentioned in the previous episode that the Greys are programmable robot types, but that sometimes they miscalculate their entry.

Heather: Yeah, their minds are programmed. Their minds are similar to ours, but they're more computer-like. There's more electronic materials that are going on inside their bodies, although some are very biologically built.

So if you think about DNA being the unit of how everything's built and as being a communication to RNA on how to make a cell, their bodies are capable of regenerating a lot of parts on their own, sort of like how ours are, except they are programmed by higher alien races, and they are able to control the craft as if they're the CPU on the craft controlling the movements of it.

David: So, **Corey**, have you heard anything about there being Greys or any other operator where their brain becomes part of the CPU of the craft and how it functions, like she said?

Corey: Well, yes, our craft operate that way now.

David: Really?

Corey: It's bio-neuro interface. Yeah, their hands – now it's a type of glove that has little pieces in the glove that are metal that interface with our neurology. And then it wirelessly goes to the craft.

David: Hm. So what would make them crash when they come in? Why would they not have the ability to fly the craft correctly?

Heather: It's a bit similar to us moving a space shuttle through the atmosphere. There is particular areas where you want to come into the atmosphere, not only for landing purposes, but for frictional heat purposes.

And this material that they use is more resistant to frictional heat than, say, the space shuttle. And there is things like lightning in our atmosphere, and there's actually been crashes as a result of lightning interference.

David: Hm.

Heather: So a strong bolt of electricity can just temporarily mess up their trajectory, their readings.

Corey: Guidance, yeah.

Heather: Yeah.

David: You also mentioned the Roswell crash, 1947, that a being was telepathically communicating with someone.

Heather: Yes.

David: Can you just share that story with us really briefly?

Heather: Yes. There was a nurse with the military at that time, and she was actually brought in because some of the bodies were not functional anymore. But there was a particular being that was still functioning and still . . . I guess “alive” would be an appropriate term for this.

And she was the only person in the military at Roswell that the being would communicate with. And she interpreted that as telepathic communication.

She realized that she was having thoughts that were not of her own. She was having thoughts about things that she doesn't have knowledge of, and that's how she realized the being was communicating with her.

David: Wow!

Heather: There's actually a book available on this. It's called “Alien Interview”.

David: And your father told you that this book was actually authentic?

Heather: Yes. Yes. We used to have Monday night meetings at a friend's house, and we would talk about things like this book. And he said that, “Yeah, I can attest that a lot of that information in there is very true.”

David: Hm. Okay, so this gets into a big, big subject. If they have gotten these disks, and you're saying now that they were able to successfully reproduce them to some degree?



Heather: Yes.

David: Okay. Then these are interplanetary craft, correct?

Heather: Mm-hm.

David: So you must have asked him at some point if they had gone out into our solar system, if they had built anything, if they had done anything, if they had found anything. So let's open that up now.

Heather: The UFO disks are more like just for transport purposes, where they come here to get data or perform abductions. They actually go to another place, maybe a larger craft or space station where they dock.

David: The UFOs do?

Heather: Yes.

David: Okay.

Heather: Yeah. The craft I'm referring to are too small to really have any other functionality except transport.

David: Okay. But as far as folks from Lockheed and other defense contractors, once they gain the ability to leave the Earth, what are they doing out there? Did they find anything?

Heather: They have seen things that look like large pieces of equipment in our solar system, but they don't know what the functionality of that equipment is, other than that we did not put it there.

David: Now, you also had mentioned to me before that he discussed something having to do with Saturn.

Heather: Yes.

David: And could you get into the subject of Saturn for a moment with us now?

Heather: Sure. There are . . .

David: And how did this come up? When did you first hear about this?

Heather: I probably heard him make these statements when we were having conversations, probably when I was in my 30s.

David: Okay.

Heather: So this is more recent information. And he described to me there being over 60 moons around the Saturn system.

If you go beyond the moons that we typically hear about, the larger moons, the ones that have atmospheres or a lot of geology, you find some misshapen moons out there that kind of resemble asteroids.

There's one in particular. The name of the moon is Hyperion.

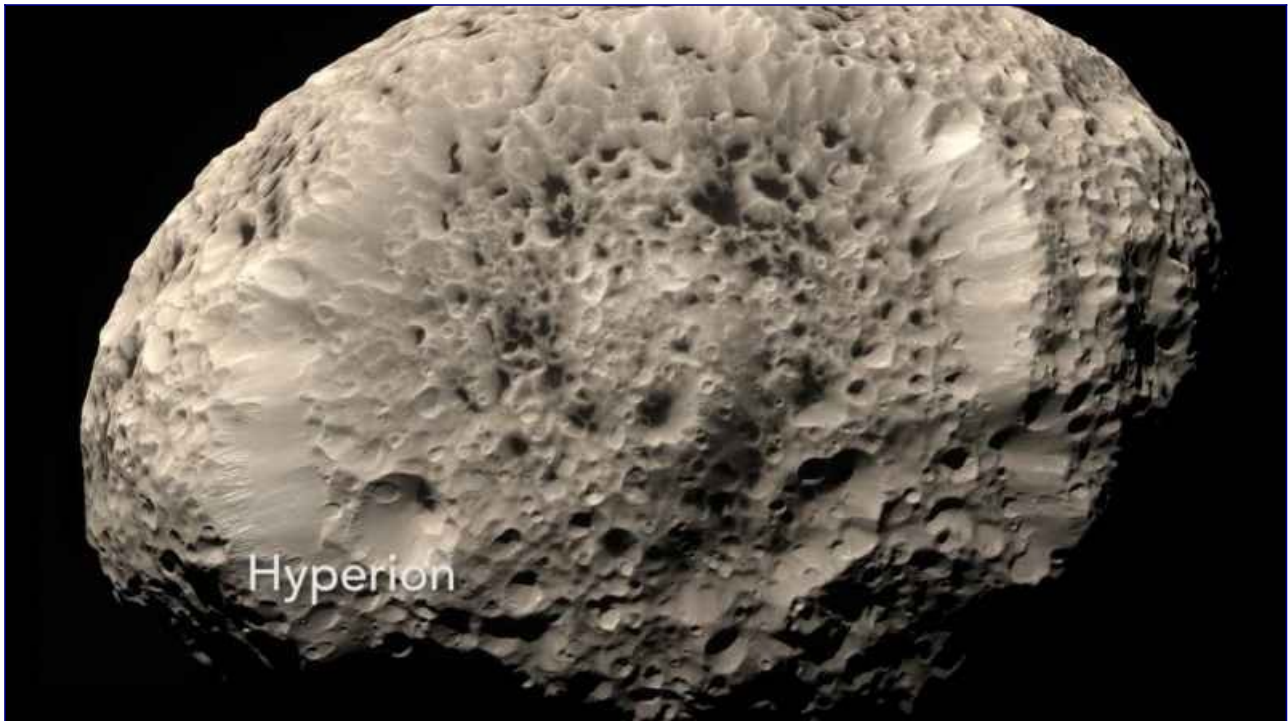

It has deep cavities in the moon. It almost looks sponge-like.

David: Is that what it's called to everyone out in the known world, or is that what the secret program calls it?

Heather: That's what you're going to find in science books as far as a name is concerned, but NASA refers to that moon as Saturn 7 moon.

David: NASA calls it Saturn 7?

Heather: Yes.

David: Because it's the seventh one out from Saturn?

Heather: It's the seventh one in that profile of moons, yeah.

David: Oh, okay.

Heather: And there is a vault that our government is storing inside one of the cavities of the moon that contains very important information and materials.

David: Hm.

Heather: And the reason it's out there is because we cannot house this stuff on Earth. The contents of this vault, I have no knowledge of, but it's very important information, if not technology or something we may need in the future.

David: Okay, **Corey**, does any of that sound familiar to you?

Corey: Absolutely. Yes, I had heard tale that there was a vault, and that it was for continuity of species if something were to happen on Earth. It has seed banks, genetic banks to reproduce every living organism from microbe up on this planet, and also it's a data repository.

David: Hm. We've talked on the show a lot about ruins in the solar system and stuff that might be pretty old, and I'm wondering if you've ever heard anything about that?

Heather: Yes, we've had conversations, my father and I, about the pyramids on Mars and Earth. These are, from what I understand from him, location areas for pinpointing a particular area of the planet for manipulation purposes.

And one of those manipulation purposes is controlling the Earth's inner core, which then, in turn, affects the Earth's magnetic field tremendously.

David: Well, we do know that the largest amount of land, in terms of longitude and latitude . . . If you actually draw lines around the Earth, the greatest amount of land coverage is . . . it crosses where the Great Pyramid is.

So the Great Pyramid is like at the balance point of the Earth's actual continental mass. And that sounds similar to what you're describing.

Heather: Yes, it does.

David: So he said that Mars has pyramids that serve the same function?

Heather: Yeah, but more in ancient times. From what I understand, there was a lot more activity on Mars in ancient history than there is today.

David: Sure. What about the Great Pyramid here? Did he tell you anything else about it that was unusual that we don't really know about mostly?

Heather: There's a whole lot of technology under there . . .

David: Under the pyramid?

Heather: . . . that's been there for a long time and is utilized, I would say, regularly, from the way he explained it. It's still operational today.

David: In what, like a chamber? Is there a chamber under the pyramid or something?

Heather: I know it's centered and that there is a connecting-type technology in the capstone of the pyramid. So it's deep underground, but it creates a connection. And exactly what that is, I'm not sure.

David: Well, you'd mentioned something about the Earth's core. What's the relationship between the pyramid and the Earth's core?

Heather: Control. So the pyramids have a special technology that's designed to manipulate the Earth's inner liquid core.

David: Mm.

Heather: And that inner liquid core is what transmits our magnetic field. So it can be controlled on making it weak or strong.

David: And is this something that either the good guys or the bad guys in that ET sense can manipulate?

Heather: Oh, yeah, especially the Reptilians.

David: Mm. Okay, so, **Corey**, I let a lot of this fly out before I wanted to tie this back to you. Now, are you aware of there being unusual technology in or under the Great Pyramid?

Corey: I've never heard anything specific, but I've heard in the program all kinds of things, including that the capstone of the pyramids was put underneath the pyramids.

I've heard several different things about some chambers that they can't get to because there are fields protecting them.

David: Mm.

Corey: But I've never heard very detailed information that is concrete.

David: We have this really interesting clip that we're going to see now from C-SPAN, where Buzz Aldrin, the astronaut, goes on television and talks about this monolith on Phobos. Let's check out the clip right now.

C-SPAN: [Buzz Aldrin Reveals Existence of Monolith on Mars Moon](#)



David: What do you think Buzz Aldrin was doing when he mentioned this? Why would he say something like that?

Heather: Well, I think it's important to create awareness. There's very few that will come forward from the government, military, NASA included, because they are working under top-secret projects. They are sworn to secrecy.

The reason somebody would come forward like my dad has in his own not-so-directly way, but like

telling me and telling like my mother, is the information is something you feel should be shared.

It's like, why shouldn't this awareness be made to everyone? Because if you don't, you're just helping the Reptilians.

David: Sure.

Heather: And we don't want that to happen. But there's a lot of exchanges and perks that take place with our government, including technological advances, in order to suppress that awareness.

So in exchange for . . . I'm just going to use gold as an example. In exchange for gold, you don't want to create that awareness because you're allowing the Reptilians to have power.

David: Now, as far as the actual monolith on Phobos, did you hear from him about any other ruins besides the pyramids on Mars?

Heather: Yeah, definitely.

David: Could you give us some examples?

Heather: There's technology that's been found on the Moon.

David: Okay.

Heather: Astronauts have actually been on the Moon. The walks on the Moon, the investigations of the Moon are not a hoax. The Saturn 5 rocket did launch. We did make trips to the Moon.

A lot of the things the astronauts have recovered on the Moon are not going to be shown to the public.

David: Really?

Heather: Yes. The lunar rocks, to be honest with you, they resemble actual rocks. This satellite, even if it's purposely made, it's made just like a lot of other moons.

The deception lies within the fact that there are things on one side of the Moon we never see. So the synchronization process of a 28-day cycle, or approximately 28-day cycle around the planet . . . and it's

like being in your car. So you're driving around a roundabout, and a person is facing your car, and you face each other the whole way around. You're never going to see the other side of the car or the person.

David: Right.

Heather: So we call it a synchronization orbit, and it's done purposely. This is not by chance or coincidence or by nature.

David: So what did you hear is on the dark side of the Moon?

Heather: A few things, that's all I've been made aware of . . . some craft, including crashes, launch pads, stuff that's been abandoned, including old electronics that were not reverse-engineered. They're actually left there.

David: Old electronics from whom?

Heather: Other civilizations that have utilized the Moon.

David: Okay.

Heather: It is my understanding some artifacts have been brought back, but they are kept underground. We don't have public information for them.

David: You have also mentioned that your father had a friend who was deeply involved in black ops, and he's still around.

Heather: Uh-huh.

David: What was his role? What do we know about this guy that you can tell us?

Heather: I can tell you that preparations for some things that were considered conspiracy theory or hoax, such as Y2K, him and my father and a few others had prepared. This was a real and true event.

David: Yeah.

Heather: Also, December of 2012 being the end of the Mayan calendar or something else, there was something that was going to occur, and I know from the two of them talking, as well as my father talking to me, there were intentions for these events to take place, but they were stopped.

David: What events are you referring to?

Heather: Y2K, for instance, that was a planned event.

David: Oh.

Heather: December 21, 2012 being the end of the world, they already knew it wasn't. This was not an apocalyptic event of any sort. This was a preplanned event that had to do with other alien groups with bad intentions, probably the Reptilians.

David: Like a cosmic false-flag attack on Earth for that date you mean?

Heather: Yes.

David: Really?

Heather: Also a distraction . . . I've heard them talk about that this is a possible distraction. That's why it stopped. Or it was stopped by other ancient civilizations that have better technology and wisdom.

David: What was the truth behind the Mayan calendar? Did you ever hear about why the Mayan calendar was so interesting?

Heather: From what I understand in our conversations, the Mayan calendar is a piece of event record-keeping and cycles. The end of that cycle has a lot to do with moving through the zodiac and the constellations.

David: Right.

Heather: That goes back to the parallax of our planet as well. And there is no specific end to the Mayan calendar. Although it ends at that time, it is moving into another part of the zodiac.

And coming from a NASA engineer, astrology is never really talked about, but I would say that there are very specific aspects that relate to astrology that are real and true.

David: Sure. We have so many quotes from ancient civilizations talking about an expectation of some kind of solar event. **Corey** has also talked about the idea that the Sun might give off some kind of flash of energy.

I'm wondering if you ever personally encountered that from your father or other insiders, and if so, what did you hear?

Heather: Well, there is a very good reason why NASA has probes and craft that orbit our Sun. We are keeping track of these upcoming events based on changes of the Sun's magnetic field.

The Sun is like a giant magnet. It really is. It interacts with the Earth's magnetic field all the time. And the way the Sun is composed of its energy, there are going to be times when there are CMEs, and there are going to be times where there is a release of plasma.

And that affects our planet's inner core, which in turn affects earthquake activity and volcanism.

David: But you also mentioned something about the Sun releasing plasma. Is this more along the lines of what I'm talking about, like a giant flash?

Heather: Yes. This is inside the Sun's corona. So there's an outer portion of the Sun that has a strong magnetic field that extends far into our solar system that actually causes weather, not just on Earth but on other planets.

And that's actually controlled, and our government knows how to control this.

David: Really?

Heather: Some of this comes from technology of other alien groups, not just by direct communication, but from some reverse-engineering. It's a matter of fact that the reverse-engineering of these small disks that are used for transportation for the Greys works on electromagnetic field propulsions, and that has actually helped us better understand using magnetic fields of other planets.

And the Sun's magnetic field isn't all that much different, other than it's very strong.

David: Mm. So just to divert to that for a second, do we need fuel for these craft to travel, or is there something that allows them to go for a long way without requiring refueling?

Heather: No, it's free.

David: Okay.

Heather: There's electromagnetism everywhere.

David: When you say that our government has the ability to manipulate the Sun's energy, did you get any specifics on how that's being done?

Heather: Well, we've actually protected our planet several times from these CMEs and flashes.

David: Really?

Heather: Mm-hm.

David: Interesting.

Heather: But that's not to say that other groups, such as the Reptilians, can't also do the same. They've had a handle on that technology longer than we have.

David: Mm. So we know back in 1859 there was something called the Carrington Event, where the Sun gave off one of these flashes.

Heather: Oh, yes.

David: And the whole Northern Hemisphere, all the telegraph wires melted in America and everything. So what would be the effect if the CME were to hit us now? Would it be that bad if it was a direct hit?

Heather: A direct hit will definitely wipe out electro-communications, from satellites to your cell phone. It would make changes in your DNA.

This is actually one way upgrades are made. Not all upgrades are equal.

David: Mm.

Heather: These interferences or these changes that reach our planet don't necessarily kill people, but they will damage primitive technology. And I mean the technology that we're used to today, such as cell phone technology and the electricity that we use is very primitive.

David: Sure. Now, **Corey**, you'd sent me a document recently that was an Executive Order that Obama signed regarding solar events.

Corey: Yeah.

David: And could you tell us that story? Because I think right now is a really relevant time for that.

Corey: It popped up out of the blue right during the time we were talking about how a lot of the elite are expecting this large solar sneeze.



The timing of this Executive Order is more than just a little suspect, knowing what we know about what is occurring with the Sun and what all these elites are expecting.

David: Obama is basically organizing a very comprehensive directive for how we would prepare for and endure a major catastrophic solar event. That's what the document is basically saying.

Corey: Right.

David: And they come out in the open with this.

Corey: Right.

Section 1. Policy. Space weather events, in the form of solar flares, solar energetic particles, and geomagnetic disturbances, occur regularly, some with measurable effects on critical infrastructure systems and technologies, such as the Global Positioning System (GPS), satellite operations and communication, aviation, and the electrical power grid. Extreme space weather events -- those that could significantly degrade critical infrastructure -- could disable large portions of the electrical power grid, resulting in cascading failures that would affect key services such as water supply, healthcare, and transportation. Space weather has the potential to simultaneously affect and disrupt health and safety across entire continents. Successfully preparing for space weather events is an all-of-nation endeavor that requires partnerships across governments, emergency managers, academia, the media, the insurance industry, non-profits, and the private sector.

David: So why do you think they're doing that now?

Corey: These groups have different ideas about what will occur when there is a solar flash, but they all understand the fact that it's going to be big, from taking out electronics to mutating our genetics.

David: Just like she was saying.

Corey: Just like she was saying.

David: So, **Heather**, based on the fact that we have so much insider testimony saying the Sun is going to give off a massive energy release, from people that **Corey** has been talking to, I've spoken to many of the other insiders, and there's so much ancient wisdom about it and also scientifically provable data, could you get a little more specific about who have you spoken to who, if they did, said anything about the Sun giving off a huge flash?

Like what did you hear about it? Who told you? Could we get into that a little bit?

Heather: The only specific details I have on a CME or a blast from the Sun's corona is from science and technology, my own education, talking to planetary scientists that I know.

David: Okay.

Heather: And it is a fact that the Earth's magnetic shield is very weak right now. When it's stronger, we have a lot more protection from that much energy being directed at this Earth, because that electromagnetic shield repels it.

David: Right.

Heather: And so it's a matter of, will we have a stronger magnetic field when this happens? And since that can be manipulated, the question is, who will manipulate it, and when will this be done in a timely manner?

David: What is it like for you being a college professor and having knowledge of things like this? Have you had times where you want to tell your students about some of this stuff? And what would happen if you did?

Heather: There's been times that I might shed an opinion or something that they may have seen on television, such as different alien groups. There are chapters in our textbook where we talk about life in the universe and the possibilities of that.

And we can actually attribute all of that to the Kepler Space Telescope, as well as the Spitzer Space Telescope, as well as the Hubble Space Telescope.

We've discovered so many planets that have some of the same constituents of our planet that you almost can't put that in a textbook that life isn't possible elsewhere.

David: Sure.

Heather: We can also thank the Drake equation from 1969.

David: Yeah, which has now been completely disproven because there's 40 billion watery Earth-like planets just in the Milky Way galaxy, and that's now NASA data. Without saying that.

Heather: Exactly.

David: So you told us off camera that you also have had interaction with NASA astronauts who told you some things that they're definitely not going to say publicly. So could you describe a little of that for us now?

Heather: Yeah, just a little information. I won't disclose who I've spoken to, but astronauts have seen a number of UFOs while they are in low Earth orbit in the space shuttle.

Some have knowledge from collaborations with others in the military. Some have backgrounds in the military that date back before their time with NASA, where they have actually had encounters with aliens and also spacecraft.

All of that has been kept closed and top secret, but they will either disclose it to friends . . . Some have come forward on television. There's no doubt about that. You've mentioned one of them.

David: Buzz Aldrin, Gordon Cooper. Um-hm.

Heather: Yes. And they do have interactions with craft, with aliens. They have knowledge of it.

David: Some of our astronauts have had direct interaction with extraterrestrials?

Heather: Yeah, in their military careers, . . .

David: Ah.

Heather: More so in the military, not so much with NASA.

David: We're out of time for this episode. I was curious, **Heather**, if you have any final thoughts, anything you'd like to share with the audience based on all that we've been discussing here?

Heather: Yeah, I think that the more we make awareness happen, the more people that disclose and our role in this collaborative effort, the better things are going to evolve and advance.

David: Well, **Heather**, this has been awesome. I really want to thank you for being here.

Heather: I appreciate being here.

David: You've had a lot to say, and it's been really amazing. And, **Corey**, again, thanks for being here.

Corey: Thank you.

David: And thank you for watching. This is “[Cosmic Disclosure](#)”. I'm your host, [David Wilcock](#), here with **Corey Goode** and our special guest, **Heather Sartain**. Thanks for watching.

[Cosmic Disclosure: Law of One and SSPs: Negative Forces](#)

Season 7, Episode 3

David Wilcock: All right, welcome back to “[Cosmic Disclosure](#)”. I'm your host, [David Wilcock](#), and I'm here with **Corey Goode**.

And in this episode, we are continuing our stunning investigation, by popular demand, into the amazing correlations between what is in The Law of One material and **Corey's** own direct experience with the Secret Space Program.

There's a lot of things in here that many people might not catch. I've been a Law of One scholar since 1996, and so I've ferreted out some very interesting stuff that, even if you've read The Law of One, you might have skipped.

So, **Corey**, welcome back to the show.

Corey Goode: Thank you.

David: Okay, so **Corey**, when we last taped the show, you hadn't seen The Law of One at all. Has that changed since then?

Corey: Yes. Actually, I was able to read the first book of The Law of One. I only read it once.

And there's a lot to retain, so I'm going to need to read it a few more times, obviously.

David: Yeah. When I first got into it, I would spend 45 minutes without turning the page, just intensely concentrating. The verbiage is very difficult. And what I'm going to do for you guys is make sure that I try to interpolate this as much as possible.

But we are picking up where we left off in a previous episode, so let's just dive right back in.

CAN YOU NAME NAMES?

So can you name names? This is a question that's being asked.

[11.19](#) Questioner: Can you name any of the recipients of the crusaders' – that is, any names that may be known on the planet today?

David: [The crusaders], of course, are the Draco beings.

So now, the questioner, Don Elkins, is basically trying to find out, okay, who has been contacted directly by the Draco? Can you actually give us a name?

And you know Ra is really touchy about that, because of free will. Unless somebody is dead, they can't. And even then, they're really worried about free will.

So the answer gets a little complex because of that.

Ra:... I am desirous of being in nonviolation of the free will distortion.

David: So clearly, again, they don't want to say what's really going on here. They don't want to get too far over the edge.

To name those involved in the future of your space/time is to infringe; thus, we withhold this information.

David: But of course, if they did, it would be the Council on Foreign Relations, Trilateral Commission, the Illuminati bloodline families . . .

Corey: Council of 300, all of the think tanks . . .

David: It's very clear that that's what they're kind of alluding to, but they don't really say. And they do actually mention people running the financial system at some point in here.

We request your contemplation of the fruits of the actions of those entities whom you may observe enjoying the distortion towards power.

David: So there you have it right there. The distortion towards power just means people who have created financial power, worldly power. And these are the people that have had contact with what they're calling the Crusaders of the Orion, which is the Draco.

In this way you may discern for yourself this information.

David: So have you noticed, **Corey**, in dealing with these beings yourself, that there are things that you'd like to ask that they balk on, they don't want to just give you the answer to every question that you ask them, like the Blue Avians?

Corey: Absolutely.

David: Could you give us some examples?

Corey: Not really because it has to do more with personal life kind of things going on.

David: Okay.

Corey: But the response is always, they've got to be careful of violating free will. And also, if they've given me information and I shared it in an unloving way, or not the right way, with another person, I've been talked to about violating the free will of others.

David: Well, you also, in one of our update episodes, described a situation where you injured your knee falling down a ramp coming out of the SSP craft, and that they didn't actually heal you.

Corey: Right. That was the Mayan group.

David: Yeah. And it was apparently you needed that karma for some reason.

Corey: Right.

David: Okay.

We shall not interfere with the, shall we say, planetary game.

David: So clearly, there is some degree . . . They do talk about that the Guardians are allowed to make sure the harvest goes well. And “harvest” refers to this Ascension event.

But for a large amount of time, they don't really want to interfere. We have to do this ourselves.

And is that, again, similar to what you hear?

Corey: Yes, and interesting enough, this whole situation is referred to as a “game”, or “the game”, by a lot of the elites.

David: Ah! Right. So there's a lot of correlations here.

It is not central to the harvest.

David: So this event is going to take place regardless of whether they tell us who these people are or not.

Corey: Right.

David: The real thing is about opening the heart, being more loving, more service-to-others oriented, as you've said so many times yourself.

Corey: Absolutely.

HOW DOES ORION TEACH?

David: Yeah. So how does Orion teach? This is a big question.

[11.20](#) Questioner: How do the crusaders pass on their concepts to the incarnate individuals on Earth?

Ra:... There are two main ways, just as there are two main ways of, shall we say, polarizing towards service to others.

There are those mind/body/spirit complexes upon your plane [people] who do exercises and perform disciplines in order to seek contact with sources of information and power leading to the opening of the gate to intelligent infinity.

David: Now, **Corey**, as you read this, the idea of “doing exercises and performing disciplines to seek contact” - what does that remind you of, or what are you thinking would be happening that would relate to that?

Corey: Secret societies and the ancient mystery school teachings that they have taken and corrupted is what pops into my mind.

David: Are some of these people actually practicing meditation and trying to do – even if they're very negative – they're doing a meditation practice?

Corey: Oh, yeah. They meditate.

David: Okay. And do you think that all of the blood trauma type of stuff that they do is related to this, as well?

Corey: It could very well be related, because blood sacrifice . . . All of these deplorable practices that they do, they have multiple reasons why they do them.

Of course, they want to have the person commit this type of crime to be able to use it over them. But also, they use it to affect the person's energy and psyche, to start to manipulate their psyche.

David: Well, now, you've spoken before about this very bizarre situation that took place between Jack Parsons, allegedly one of the founders – well, not allegedly, we know he's one of the founders of NASA – and L. Ron Hubbard, where they did this thing called Babalon Working. And they were trying to summon, inside a magic circle, some kind of spiritual creature.

And you said to me in private conversation that those rituals that took place over several days actually had some very destructive effects.

Corey: Yes. And there have been reports that I've heard of, out in the middle of nowhere – let's use where we are now as an example, in the Boulder [Colorado] area – off in the mountains away from all prying eyes, these groups will get together, form a circle, and do some sort of a ceremony.

And many times, a Reptilian will appear in the middle.

David: Really?

Corey: Yeah.

David: Now, you mentioned before that there were actual damages in the Earth's protective field caused by that ceremony that Hubbard and Parsons had done.

Corey: Right. It had opened some sort of a rift.

David: And you had mentioned the idea of somebody going with like a boxcutter knife alongside a sheet . . .

Corey: Right.

David: . . . and like slashing long holes in the sheet as they walked by.

Corey: Right.

David: So as the Earth rotates and they're doing this Babalon Working at a particular latitude line, is there some type of tear that they cause in the Earth's energy field that rotates as they continue doing it?

Corey: Right. It's just like if you took a globe, spun it, and then took a Sharpie and touched it to the globe as it was spinning. It's going to leave a streak.

David: And what was the effect of this tear? What happened once they created that tear?

Corey: This tear allowed beings from another dimension to have access to ours.

David: So it's actually . . . it creates a portal that they could get in through that they otherwise wouldn't have.

Corey: Right. But it ended up being one that they could not close.

David: It seems pretty bizarre that just a couple of people could do this much damage. Why do you think it works that well?

Corey: Well, I mean, you've spoken many times about small groups of people getting together causing major effect on the larger population.

David: In the meditation effect for a positive sense, yeah.

Corey: Right. Well, why wouldn't it work for a negative sense as well?

David: Okay. So this is one of the ways that the Orion, or the Draco, would contact individuals incarnate on Earth. And they said there was two ways. So let's keep going.

There are others whose vibratory complex is such that this gateway is opened and contact with total service-to-self with its primal distortion of manipulation of others is then afforded with little or no difficulty, no training, and no control.

Corey: So basically, they're just evil enough to where birds of a feather . . . and they come together kind of thing.

David: Sure.

WHAT INFORMATION?

David: Okay. So then the next question that they ask is:

[11.21](#) Questioner: What type of information is passed on from the [Orion] crusaders to these [incarnate] people?

David: And this is a pretty simple answer.

Ra:... The Orion group passes on information concerning The Law of One with the orientation of service to self.

The information can become technical just as some in the Confederation, in attempts to aid this planet in service to others, have provided what you would call technical information.

The technology provided by this group is in the form of various means of control or manipulation of others to serve the self.

David: So this is interesting, because what they're basically describing here – first of all, technological information being provided by the crusaders – wouldn't you say that lines up perfectly with Nazi Germany in the 1930s?

Corey: That the negatives were imparting this information?

David: Yeah.

Corey: Absolutely, yes.

David: So actually giving the Germans the ability to perfect their flying saucer technology. You had said before that the Americans didn't have as much ease in getting these reverse engineerings to work.

Corey: Well, the main reason was that they were completely scientific minded. They were not using these occult-type practices with science together.

David: Ah.

Corey: That's what the Germans were doing. They would have test craft. They would put all kinds of runes and glyphs all over them, do ceremonies, and couple that with the technology they were developing.

David: So based on what The Law of One is saying here, it would imply that actually putting those runes on their craft, or the swastika and shapes like this, somehow allowed the negative to give them more information about how to perfect the technology?

Corey: Right. And just like on the positive side, who was that famous mathematician we were talking about in the car yesterday who was getting this type of information, but positive information, about mathematics and physics from . . .

David: Oh, Srinivasa Ramanujan?

Corey: Yes.

David: Yes.

Corey: Yeah. So it happens on the dark side and the light side.

David: Right. As the quote goes on, though, they start to talk about mind control systems. And let's read a little bit more before we discuss this.

So they're talking about “various means of controlling and manipulating others to serve the self”. One of those would be, of course, building UFOs allows them to control the planet, to have a weapon that they could fake an alien invasion with, for example.

But it also gets into mind control.

NUCLEAR ENERGY

So then he says:

[11.23](#) Questioner: Is this how we learned of nuclear energy?

And the answer is actually pretty interesting.

Was it mixed, both positive and negative orientation?

Ra:... This is correct.

So that's pretty interesting right there, the idea that this really messy, dangerous power source was partly given to us by negatives because it would cause a lot of damage if it was used.

Corey: Right. And what I've heard is a lot of the Reptilian vessels use a dirty type of power plant.

David: Oh, really?

Corey: Yeah. It doesn't affect them, the radiation, but human beings would not be able to last in those craft very long.

David: Well, and you're also familiar, I'm sure, with how American power plants use so much of this heavy water, and they leave the waste products stored in these giant tanks.

And there's been a plan to try to hit the fault line going through the middle of America, and they put all of these power plants along the fault line, and create a big disaster that way, but the positive beings have stopped this from happening.

Corey: Yeah. That was, at the least, very poor planning.

David: Yeah. But it seems intentional.

Corey: Right.

David: These guys are really crazy.

The entities responsible for the gathering of the scientists were of a mixed orientation.

The scientists were overwhelmingly positive in their orientation.

David: This includes Einstein. They talk about that.

The scientists who followed their work were of mixed orientation including one extremely negative entity, as you would term it.

David: And they never really say who that is. And it would be useless to really try to speculate on it.

But it's interesting here, because look at what they're telling us. The initial wave of people that make these breakthroughs that are used by the negative, the initial wave is positive. So they're protected. Their free will is protected. They're allowed to make these huge breakthroughs.

Corey: That is no different than what occurs in the military-industrial complex today. Many of these engineers and physicists, all the different scientists, feel like they are saving the world. They feel like they're doing a very good thing.

David: Right.

Corey: And they put in the work. And, of course, above them, there's no need to know what happens after that, so they have no idea what's going on.

ORION DARK FLEET

[11.24](#) Questioner: Is this extremely negative entity still incarnate on Earth?

David: This is 1981.

Ra:... This is correct.

David: So, again, you could speculate about who this is, but we don't really know.

[11.25](#) Questioner: Then I assume you can't name him.

David: The answer, of course, is yes.

[12.2](#) Questioner: [You] mentioned that the Orion crusaders came here in chariots.

David: Now, “chariots” is their term for basically flying saucers or what we could call UFOs.

Corey: Chariots of the Gods kind of thing.

David: Yeah. Because it's a chariot of war.

[Could you] describe a chariot?

David: This gets interesting, because the Dark Fleet stuff you've told us? It's amazing how much correlation there is here. Wait till you see this, dude.

Ra:... The term chariot is a term used in warfare among your peoples.

That is its significance.

The shape of the Orion craft is one of the following:

David: I've been waiting for so long to see your live reaction as we do this.

Corey: Triangles?

David: Well, just wait.

Firstly, the elongated, ovoid shape which is of a darker nature than silver but which has a metallic appearance if seen in the light.

David: What do you think of that?

Corey: Sounds very familiar to some of the art and descriptions that I've given.

David: When you did the art, when we commissioned the art about the battle that was taking place over Antarctica, tell us a little bit about the shutdowns again. What was happening there?

Corey: Right. And these were actually Dark Fleet vessels, . . .

David: Yep.

Corey: . . . according to the intelligence. And there were six of them that were trying to leave . . . that left from under the ocean close to Antarctica and were trying to leave orbit.



And we had dozens of what were described as Chevron craft of unknown origin came in and attacked them, and caused enough damage that they retreated back the way they came.

David: So they're elongated ovals just like it says here.

Corey: Like teardrops. Like teardrops.

David: . . . “a darker nature than silver”.

Corey: Right. Often described as pumpkin seed shaped.

David: Right. And I did not actually see this in The Law of One until originally it was April 2016, after you'd already made that graphic. And then I wanted to do some of these episodes.

And I was shocked because it's one thing to kind of get loose connections. But when you have The Law of One, as we've said in previous episodes, describing our government having bases on the Moon, that they're in the process of being rebuilt and expanded, bases that move along the surface of the Earth,

bases under the sea – there's so many correlations with the things that you've said that nobody was talking about in UFOlogy back in 1981.

And here's another example. It's totally amazing.

So this perfectly fits with what you said.

In the absence of light, it appears to be red or fiery in some manner.

David: I'm curious, what are your feelings on that?

Corey: That definitely describes some of the craft. I haven't heard it mentioned directly in correlation with just the Reptilians, but even the cosmonaut-type spheres that were over Antarctica during that time observing, when they're inside the atmosphere moving around, they have kind of an orangeish-red corona.

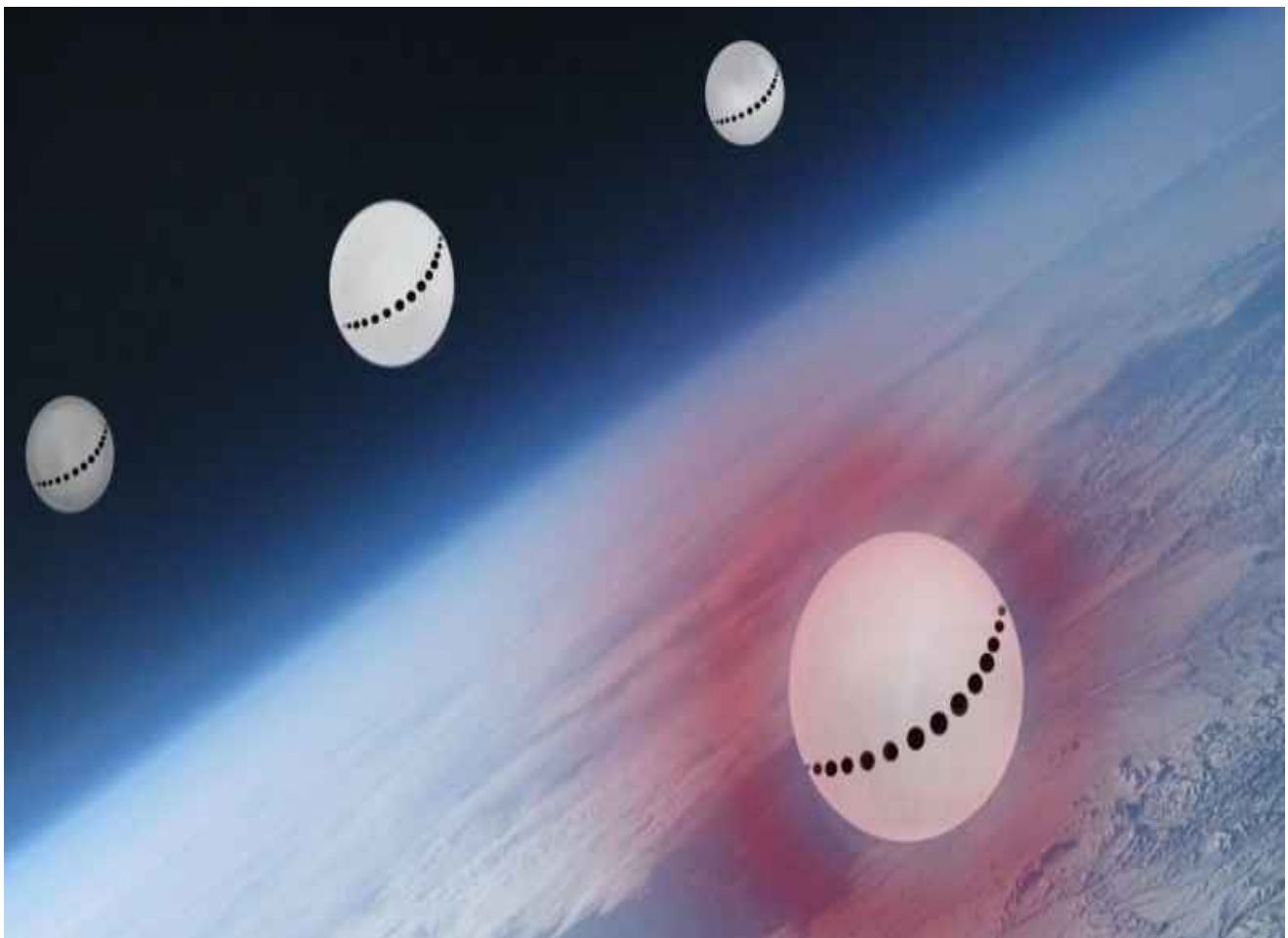

David: So this perfectly fits once again. Well, there's another type.

Other craft include disc-shaped objects of a small nature approximately twelve feet in your measurement in diameter,

the box-like shape approximately forty feet to a side in your measurement.

Other craft can take on a desired shape through the use of thought control mechanisms.

David: So we have three things here. We have flying saucers 12-feet wide, a box type of shape, and then they can create anything that looks like what they want.

Corey: Well, and also, they have what look like metallic craft. And there would be rooms inside, and with electric stimulation they would change shape. They'd go into balls, they would flatten out, and then the rooms on the inside would move around . . .

David: Oh, wow!

Corey: . . . to match the shape change. So in flight, they could change from a cigar shape to a flat circle or a disk. They can change actual shapes.

David: Well, yeah. There are also UFO sightings not only of craft changing shape, but of actually splitting and going off and becoming two.

Corey: Hm mm. Yeah. They do that too.

David: Is that also what it can do?

Corey: Yeah.

David: Wow! Yeah, you never said that on the show before.

So as far as like a 12-foot disk, is that one of the sizes that you've seen?

Corey: Yes.

David: Maybe more like a drone craft or something?

Corey: Yeah. Those smaller ones are usually drones . . .

David: Okay.

Corey: . . . around that size, like six to 12 feet.

David: And I also know, in some of the same art that you already had commissioned back before I saw this, that you did describe squarish craft that the Dark Fleet have.

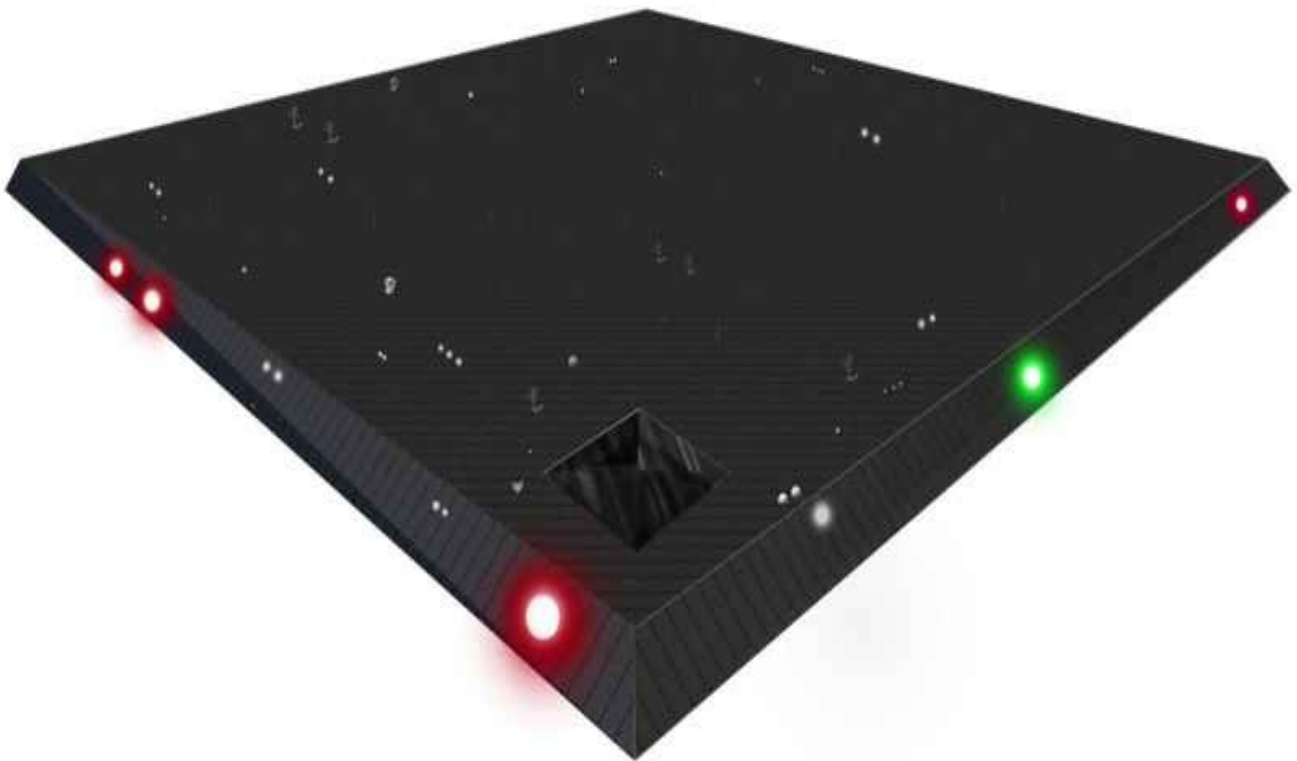

Corey: Indeed.

David: And it says right here, boxlike shape 40-feet to a side. So again, very, very nice lineup here. It's amazing.

VARIOUS CIVILIZATIONS

So now they're going to talk about that . . .

There are various civilization complexes which work within this group.

David: Meaning it's not just one type of extraterrestrial race.

Corey: Well, yeah. That matches the conquered race that I've told you about that a lot of people confuse with Nordics.

David: Right.

Corey: They're like eight foot tall. They have the taller foreheads, receding hairline kind of a thing, kind of the same bob haircuts, blonde hair, big blue eyes, six fingers.

David: Right.

Corey: And the intel on them is that they're a conquered race, just like we supposedly are. And just like we have Dark Fleet going out with the Reptilians on conquests, that's what these beings are doing.

David: And those are some of the most troublesome ones, right, that particular group?

Corey: They're the ones that we've seen a lot in conflicts. So, yeah, they'll send those beings in as cannon fodder a lot of the time.

David: Wow! Interesting.

Some are more able to use intelligent infinity than others.

David: That means their ability to manipulate consciousness, their kind of magic powers like telekinesis, telepathy. So would you agree with that?

Corey: Absolutely, yes. Yeah, I mean, there have been many accounts of people going to some of these bases where there are Reptilians, or these Nordic-type groups that I've told you about that are walking around with these big pelican cases that hold equipment, levitated, floating behind them as they walk along.

David: Right.

The information is very seldom shared; therefore, the chariots vary greatly in shape and appearance.

David: In other words, the Draco, even if they have people working with them, they don't necessarily want to give them that much technology.

So it's kind of like, "Come with whatever you've got."

Corey: Yes. And the Dark Fleet have much more advanced technology and weaponry than the other space programs, most of them. And their technology has been enhanced by this Draco group, but not enhanced to a point to where they could become a threat to them.

David: Right. That makes perfect sense.

Now they talk about the Quarantine. This is an interesting discussion we've had many discussions about.

THE QUARANTINE

[12.3](#) Questioner: Is there any effort by the Confederation to stop the Orion chariots from arriving here?

David: Of course, now with the Spheres and the Outer Barrier, it's gotten much more.

Ra:... Every effort is made to quarantine this planet.

However, the network of guardians, much like any other pattern of patrols on whatever level, does not hinder each and every entity from penetrating quarantine, for if request is made in light/love, The Law of One will be met with acquiescence.

David: So this is something that I've heard from several other insiders, and I definitely wanted to get your take on it in these Law of One episodes.

Is there some kind of energetic barrier around the Earth that at times prevents people from just being able to come in and leave whenever they want?

Corey: Absolutely. They have to, I guess, come in and leave in a certain way, in a certain trajectory, that is monitored. If they come in through any of the other ways, then they can risk damage to their vessels.

David: Right. So this is what The Law of One calls the Quarantine, and they explain that they do not hinder every entity from coming in.

Corey: Which will coincide with some of the beings that I told you that, when the Outer Barrier was erected, there were a lot of beings that ended up getting trapped here that are extremely benevolent.

David: Right.

Corey: And that included the groups that were here that couldn't care less about us, that were just here to study the rainforests or the ocean life.

David: And I also have heard from other insiders that the Quarantine actually does involve, to some degree, physical microsattellites in Earth's orbit that enforce this protective grid in some way. Have you heard something like that, that there are . . . ?

Corey: I know that WE have put out swarms of very tiny satellites that are out there for monitoring and defending the planet.

David: Okay. That's the same thing I heard from others.

If the request is not made, due to the slipping through the net, then there is penetration of this net.

David: So some entities can randomly get through.

[12.5](#) Questioner: I didn't quite understand. How does the Confederation stop the Orion chariot from coming through the quarantine?

Ra:... There is contact at the level of light-form or lightbody-being depending upon the vibratory level of the guardian.

David: So what they're actually saying here is a light-form might be like a wall of light. It might appear as a craft. Lightbody-being may actually be some sort of apparition.

But what it's saying is that a lot of these entities would try to get in, and they're going to run into something that would stop them.

These guardians sweep [the] reaches of your Earth's energy fields attempting to be aware of any entities approaching.

An entity which is approaching is hailed in the name of the One Creator.

Any entity thus hailed is bathed in love/light and will of free will obey the quarantine due to the power of The Law of One.

David: Now, this is all very nebulous, so we're going to keep reading because it'll all make sense in a second.

[12.6](#) Questioner: What would happen to the entity if he did not obey the quarantine after being hailed?

Ra:... To not obey quarantine after being hailed on the level of which we speak would be equivalent to your not stopping upon walking into a solid brick wall.

David: So anyway, it's describing a solid energetic barrier, something that you just can't go through it no matter what.

Corey: Right. And science has discovered interesting energetic anomalies around the Earth.

David: Absolutely.

[12.7](#) Questioner: What would happen to the entity then [if] he did this?

What would happen to his chariot?

Ra:... The Creator is one being.

The vibratory level of those able to reach the quarantine boundaries is such that upon seeing the love/light net it is impossible to break this Law.

David: So that . . . I highlighted “love/light net”, because it is apparently some kind of grid-like mesh of light that they just can't get through if they're trying to get in other than the normal way to get into the planet.

WINDOWS IN THE NET

Therefore, nothing happens.

No attempt is made.

There is no confrontation.

The only beings who are able to penetrate the quarantine are those who discover windows or distortions in the space/time continua surrounding your planet's energy fields.

David: This opens up a huge discussion, because what they say is that if our free will on Earth gets shaky enough, they have to allow a certain amount of random windows that can, they might only be very brief, but they allow the bad guys to come in for just a short time and then get back out again really fast.

Through these windows they come.

These windows are rare and unpredictable.

David: So this is something that's allowed to happen by our own free will.

WHO GETS CONTACTED?

Then it says:

[26.34](#) Questioner: Is it necessary in each case for the entity who is contacted in one of these landings to be calling the Orion group?

Or do some of these entities come in contact with the Orion group even though they are not calling that group?

Ra:... You must plumb the depths of fourth-density negative understanding.

This is difficult for you.

David: So we're seeing they're setting us up here for something interesting.

PLUNDER AS THEY WILL

Once having reached third-density space/time continuum through your so-called windows, these crusaders may plunder as they will,

the results completely a function of the polarity of the, shall we say, witness/subject or victim.

David: Dude, this is the Galactic Slave Trade. They are describing exactly what you've been telling us right here in The Law of One, that they may plunder as they will. The people who are plundered do not necessarily have to be consciously calling the Orion group.

But then, notice it says the results are a function of their polarity.

So I know that when you've talked about the Galactic Slave Trade, it would appear that just anybody could get picked, and that's going to freak a lot of people out.

Corey: It's because humans are the ones collecting the specimens that are sent off planet into the slave trade. In the beginning, they were just being taken, and then the secret space programs, once they had more control over our airspace, the powers behind that force decided, "We can use these people as a commodity for trade."

And that's how having a large piece of the human trade business came about.

David: So then it says:

This is due to the sincere belief of fourth-density negative that to love self is to love all.

David: So they believe that they are the elite, they are the special, and that they love themselves, and that other people do not love themselves as much as they do. Therefore, they've become god where none exists and everybody else should worship them.

Did you encounter that type of belief in the Cabal in the times that you saw this stuff going on?

Corey: I guess they obviously passed that way of thinking down to their human minions.

David: Sure.

Corey: Yeah.

TEACHING LOVE OF SELF

Each other-self which is thus either taught or enslaved thus has a teacher which teaches love of self.

David: That's just like what you were saying. The elite pass this down to everyone else.

Exposed to this teaching, it is intended that there be brought to fruition a harvest of fourth-density negative or self-serving mind/body/spirit complexes.

David: Now, do these people believe in their own form of Ascension, just like it's saying here, that they're going to ascend?

Corey: Yes. Yeah. Some of them believe it will be a technological Ascension. Most of them do.

They are AI prophet-type people. And as it turns out, many of the Draco seem to be as well.

David: Right. But there's others that would actually believe in a sort of spiritual Ascension, as well?

Corey: Right. There are so many different esoteric and other type of beliefs among these groups. Very few of them agree on their belief systems. They just agree on their overall agenda.

David: All right. Well, since we've talked about some pretty disturbing stuff in this episode and we're out of time, I mean, The Law of One does say – and I want to point this out – they make it very clear in here that the negative is never allowed to do more than what is required to awaken humanity, that by having this great villain in the planetary game, we become . . . our hearts open up and we realize that there is a reason to want to be more loving, there's a reason to want to be more positive, there's a reason to want to save the Earth, to protect the animals, to seek truth and justice and freedom and liberty.

What do you think is the big vulnerability of these negative forces? What is their critical weakness that the positive groups will ultimately use against them and are using against them?

Corey: Their complete devotion to self. You know, they're . . .

David: How does that bring them down?

Corey: These groups are also so interrelated on their hierarchy that, if they can disturb or affect any of the upper hierarchy beings, it trickles down to the rest.

David: So it's sort of like a computer, where you would have the CPU fighting with the memory fighting with the hard drive. You can't have a functional system when it's constantly betraying itself.

Corey: Right. Another thing this topic brings to mind . . . I hear people all the time saying, why won't the Blue Avians come down here and just squash the Reptilians? Why don't they just take an active role?

The creation of The Law of One book was to be a guide, and most of all, to stimulate our consciousness. That is pretty much all they're concerned about, is stimulating and raising our consciousness.

If they can do that, we take care of the problem ourself and they don't have to get involved.

David: Yeah. And I think that when we look at the meditation effect and how much, as you were talking about the negative can do that, a small group of people focusing on the positive can have such a hugely disproportionate effect on the outcome that, as more of us are enlightened and we realize that such evil exists, we become a lot more dedicated on our path.

And once we do, we have a dramatic effect on how this is all going to turn out. Would you agree with that?

Corey: Absolutely. The one thing that they've tried to drill into my head is that we are our own saviors. We are the ones that have to clean up this mess. They will mitigate some of the problems that we have to overcome, but we have to do all the work.

And I think we're beginning to see a change in society and things occurring in the background to where we might be on the precipice of those changes.

David: Cool. All right, well you've seen it here, a lot of really great Law of One connections to what **Corey** is saying.

As a scientifically-minded person who's written scientific books, when I look at this type of data, it's absolutely convincing to me this is not the product of coincidence or chance.

This is two different sources that are talking about the same body of true information. It's the only logical explanation.

I'm **David Wilcock**. This is "[Cosmic Disclosure](#)" here with **Corey Goode**, and I thank you for watching.

Cosmic Disclosure: Law of One and the SSPs: Consequences of Channeling

Season 7, Episode 4

David Wilcock: All right, welcome back to "[Cosmic Disclosure](#)". I'm your host, **David Wilcock**. I'm here with **Corey Goode**. And in this episode, we're going to get into the negative groups and their influence on channeling.

So **Corey**, welcome back to the show.

Corey Goode: Thank you.

David: Over the years, we've seen a whole lot of people either A, portraying themselves as fake insiders, or B, saying that they are having some sort of channeling experience. And what has been your experience with most of these channelers that are coming out on the Internet in terms of the truthfulness of what they're saying?

Corey: A lot of it is . . . I don't know, not stuff that correlates with my experiences, to put it nicely, yeah.

David: Right. And would you say that a lot of these people also seem to become culty in the way that they present themselves and in the way that their followers then encounter the material?

Corey: Yeah, and that's one of the major problems and why Tear-Eir said that they no longer use that type of communication, is because the ego distortion that people have.

People get Christ complexes, start feeling like they're the saviors. They're delivering the information that will save the world. And their head puffs up, and they get these grandiose ideas about themselves.

David: Certain individuals do have actually positive, useful channeling happening to them. I've been doing the dream research where I get my dreams every morning since September 21, 1992, pretty much every morning.

And as of November 1996, I began having a telepathic communication take place using the protocols of remote viewing. But I was having very significant future prophecies, all kinds of highly accurate things that were clearly bending reality.

So let's just confirm then that not all channeling is bad, and that it can be done, like in cases of Edgar Cayce, or The Law of One, or the Seth books. Certain people can do it actually, and do it well.

Corey: Right. Right. And yeah, I mean, I'm sure that's the case. And it's just the Blue Avians, the Sphere Being Alliance, that have told me that they no longer use that type of communication because of all the distortions.

David: But also, just so we have this on record, because I don't think that's ever been said in this show before, you've said to me, off camera, that one of the things that the Sphere Beings or the Blue Avians did tell you is that they have been also in communication with me.

Corey: Right.

David: That this was something that's been going on with me for quite some time.

Corey: Right.

David: Okay. So you can confirm that The Law of One and the Blue Avians do appear to be the same source? You now have been told this.

Corey: Yes, but they have given me a warning about The Law of One – that it was not meant to be a Bible or something that you sleep under your pillow with. It was meant to be a guide, and also to help

us expand our consciousness, which is our overall goal.

And they have stated that too many people have turned it into a religion.

David: I would agree with you in the sense that there's a lot of cracks that are left that you really need to fill in on your own. So it's always a good idea for us to make up our own minds and put various sources together and draw our own conclusions instead of just blindly worshiping one thing and saying, "This is the truth and it's all in this book."

Corey: Right. And the book is passing through all of our personal distortions on the way to be locked into our belief systems.

David: Sure.

Corey: So all of us have these personality distortions that affect and taint the information.

David: All right. Well, with all those disclaimers in place about my own channeling and that they told you that I was actually getting contact from them, so this was not a negative example of channeling. So it can be done right. But here, we're going to hear about how a lot of times, people are not getting accurate information. So let's go to the slide now.

NEGATIVE INNER PLANES

[12.14](#) There are many upon your so-called inner planes which are negatively oriented.

[They are] thus available as inner teachers or guides.

[They are also] so-called possessors of certain souls who seek this distortion of service to self.

David: Now, when they talk about inner planes, they're talking about the Inner Earth. So are you familiar with there being groups of people inside the Inner Earth who would possess individuals on the surface who are like Illuminati or negative-oriented kind of people?

Corey: Yes, there are positive and negative Inner Earth groups. And just like the Anshar, when I walked through the library and there were all these egg-shaped chairs floating off the ground with people

kicked back and looking like they're in a meditative state, they were reaching out to humanity to impart wisdom and ideas that were not their own.

David: Right. So the same thing could be done with these negative groups in there?

Corey: Absolutely.

David: Okay. So that's exactly what it says here. Now, this is where we get to the really important stuff.

MIXED CHANNELING

[12.15](#) Questioner: Is it possible for an entity here on Earth to be so confused as to call both the Confederation and the Orion groups [while they are channeling]?

David: Look at the answer.

Ra:... It is entirely possible for the untuned channel, as you call that service [meaning channeling], to receive both positive and negative communications.

Corey: And they can't tell the difference between the two. They'll be sure that it's this benevolent being that they're in contact with that they trust, and then a trickster being will come in and give them information in a similar way which is distorted.

David: Right. And this is something that I think is so significant, **Corey**, because there are so many people I've seen online who assume that if some aspect of a channeler's work is provable, or if they make a future prophecy, or if they nail something, that therefore, well, that's it. This is the stamp of legitimacy. This channeling is now authorized. It's the way it is.

But what you're saying, and what it's also saying in The Law of One, is that somebody could get positive information, which would include very accurate data and also get negative data at the same time.

Corey: It's like a man in the middle attack. You'll have contact with a benevolent being, and then one of these negative beings will slide right in the middle here, get in the channel, and distort the information or send different distorted information.

David: Well now, you may not be aware of this, but if we go back to this whole story of Edgar Cayce, who, of course, if anybody doesn't know, he did 14,000 deep trance readings that he was unaware of what he was saying while he was entranced, but yet, could diagnose people's medical problems and prescribe accurate treatments.

The Cayce readings are basically seen as sacrosanct by Cayce fans. And yet, if you study what it says, Cayce himself got angry at his haters, and it allowed a negative entity, calling itself Halaliel, to come in. And Halaliel said that California was going to sink into the ocean in 1998, which didn't happen.

Corey: If you become cynical about life, untrusting, feeling like you're under attack in certain ways, then you're definitely opening yourself up, especially if you become overconfident and you're not always testing the spirits and the information as it's coming in.

David: Now, have the Sphere Beings warned you about the possibility that this could happen to you as well – that if you became overly negative, that you could invite negative things to happen to yourself?

Corey: Definitely, yes. I could, as you say, authorize negative things to happen by my thoughts and actions.

David: So what are some of the coaching that you're been getting in terms of how you would avoid that from happening?

Corey: Doing a lot of meditation and learning the dangers of anger and jealousy, and all of these different things and what it does to you.

David: All right. Well, now let's go back to our slide. And you're going to see here what happens when somebody starts to get positive and negative communications. It's a very interesting answer. It ties in with what we've been saying.

If the entity at the base of its confusion is oriented towards service to others, the entity will begin to receive messages of doom.

David: Isn't that interesting? When you look at a wide variety of channelers, they have a predominantly positive message. At the same time, there is this streak of fear porn in it, and they think there's going to be a pole shift, or they think the economy is going to collapse, or that some kind of alien invasion is going to happen.

So what it's saying right here is that this is actually a function of the negative contact.

Corey: Well, and it's also, as we've spoken about before, why would they do this? Well, they're trying to affect our mass consciousness to have us, with the power we have, our co-creative power, to manifest what these doom-and-gloom type of prophecies . . . It becomes a self-fulfilled prophecy many times.

David: Even if somebody is really unbalanced and very ungrounded in their life, what you're saying is that even the lowliest among us, in terms of what we would normally judge people by in worldly terms, their consciousness still has a very powerful effect.

Corey: Absolutely. Every single point of consciousness, which is a human being, has the same co-creative power.

David: So have these beings also explained to you that no matter how far off somebody seems to be, that every life is valuable and salvageable and can potentially be transformed into something amazing?

Corey: Absolutely. Yeah. All of our distortions can be overcome with wisdom and knowledge.

David: All right. Well, let's go on with this because there's a lot more interesting stuff here to explore.

If the entity at the base of the complex of beingness is oriented towards service to self [ie, the negative path], the crusaders, who in this case, do not find it necessary to lie, will simply begin to give the philosophy they are here to give.

David: So this would be your Cabal type of people where they're actually getting this direct telepathic communication. Were you aware of people in the Cabal having telepathic communications with demonic type of presences?

Corey: Oh, yeah. Oh, yeah.

David: How would that look? What would they be doing?

Corey: It . . . I guess, I hate to use the word 'channeling' with the demonic side, but they do ceremonies. A lot of it involves bloodletting, sexual magic, and that kind of stuff, to get them in a state to be able to communicate telepathically with these negative beings.

David: Right. So there might be a group of people that uses one person as the channel . . .

Corey: Right.

David: . . . and then opens up that communication.

Many of your so-called contacts among your people have been confused and self-destructive because the channels were oriented towards service to others

but, in the desire for proof, were

open to the lying information of the crusaders.

who then were able to neutralize the effectiveness of the channel.

David: So I hope you can see that this is of absolutely pivotal importance. We get a lot of comments, a lot of questions, about you in particular, and people say, “Well, why can't he film a Blue Sphere picking him up? Why can't he film the craft landing in his backyard?”

And what it says right here is that that's the desire for proof.

So this is a very interesting subject because The Law of One is always talking about the first distortion, free will. Free will's so important.

And what would happen if they gave us proof? If these higher beings gave us absolute proof that they really exist, what would happen?

Corey: Most of us would succumb to our programming to worship, and we would drop to our knees. The problem they have already is thousands and thousands of people are going into meditative states and trying to reach out to the Blue Avians and are asking them things that you would hear Christians getting on their knees and praying and asking for.

So that was one of the major things that they wanted to avoid from the beginning in contact with me, is any type of worship or religion being built around it.

David: What do you think is the benefit of this material never being given absolute proof for the seeker?

Corey: These beings are not wanting to come here, appear before us, putting their arms out and saying, “Here I am; now change.” Their whole mission is to affect our consciousness in a way that we change ourselves.

David: Right.

Corey: Because they are already karmically tied to us from them trying to interfere in the past to help us change, and all it did was make things worse.

David: It would appear that when you don't get absolute proof but you get compelling clues, that that inspires the seeking. That makes people hungry for more and that quest for knowledge.

Corey: It's supposed to happen up here, not out there.

David: Right. So this is why we got to avoid the desire to prove every little thing. And to some degree, you will get subjective validation, and I think that's an important point too.

You've talked about Blue Spheres contacting people individually.

Corey: The amount of emails that I'm receiving right now from people that only discovered me a week or so before after they had a Blue Sphere or Blue Orb come into their house, zigzag around, and then leave – these are doctors, lawyers, nurses, you know.

David: Right.

Corey: And I'm getting a lot of emails from these types of people. So this is a situation that is occurring more frequently, as I was told it would.

David: And also, I would say some people might get one contact of that type, and then they keep wanting another hit, another hit, but they don't get it. And what's the benefit there?

Corey: Well, a reason that they don't get it is because they already received everything that they were supposed to. A lot of the information is imparted to their subconscious or higher self, and they have to do the work to slowly start to get access to that information.

David: Very interesting. All right, let's continue now.

WEAKER MINDED ENTITIES

[53.16](#) The most typical approach of Orion entities is to choose what you might call the weaker-minded entity that it might suggest a greater amount of Orion philosophy to be disseminated.

Some few Orion entities are called by more highly polarized negative entities of your space/time nexus.

David: So when it says “weaker-minded entity” here, what it seems to be referring to is somebody who is not necessarily strong in their faith, and they're more susceptible to being influenced by new ideas.

Those are the type of people that if they hear a voice talking in their head, they're going to say, “Well, this has got to be the voice of God, and everything that I'm hearing is the truth.”

So would you say that fits with how the Voice of God technology would work?

Corey: Absolutely. That's . . . I mean, we've described it on other episodes.

David: Are there some people who would be stronger in their mind that the Voice of God technology might not work as well on?

Corey: People that had will, had a weaker will . . .

David: Oh, interesting.

Corey: . . . were more susceptible.

David: So when a person has a stronger will, it's not necessarily going to work as well, if they can just speak a voice into your head?

Corey: Right. A stronger will, stronger-minded person that is going to question what's happening a little bit more than just going, "Oh, my goodness, I've always wanted to be in contact with another being. Here they are, so this must be a good situation."

David: Very interesting. All right, let's go on here.

In this case they share information [with the highly negative people on Earth] just as we are now doing.

David: So that's a direct Cabal type of situation.

Now, this is something the Cabal likes to do all the time. When they contact these highly negative people, it says:

However, this is a risk for the Orion entities due to the frequency with which the harvestable negative planetary entities then attempt to bid and order the Orion contact just as these entities bid planetary negative contacts.

The resulting struggle for mastery, if lost, is damaging to the polarity of the Orion group.

David: So there was a couple of quotes in here, in between where we were last time and this one, that I didn't use. But the idea here is ritual magic can, in fact, imprison a negative energy, that people on Earth can basically, as it says here, "bid and order them to do things".

And I'm curious if your experience in this underworld that you saw evidence of that being possible, that Cabal people could actually force demonic spirits to do their bidding.

Corey: Absolutely. They would use mind control, and also, entity attachments, to control and manipulate people. Well, how do they get these entity attachments to do their bidding?

They use black magic and rituals.

David: So an entity can essentially get trapped by the laws of the universe into doing something that it doesn't want to do.

Corey: Right. And many of these entities supposedly come from this place called The Outer Realm. They are here. This is not their natural environment. So they're here causing problems, but they are also susceptible to pitfalls of this environment.

David: Right. So this, again, is amazing how well what's in The Law of One correlates with what you learned from the inside of this very dark world.

Similarly, a mistaken Orion contact with highly polarized positive entities can wreak havoc with Orion troops.

unless these Crusaders are able to depolarize the entity mistakenly contacted.

David: So I think this is a really interesting key here because . . . Like, for example, we've talked off camera quite a bit about the weird negative greetings that have happened to both you and me in Law of One terms, “negative greeting” meaning weird, bad, interferences that happen.

It's like every time we come out to do this show, there's strange, occult, weird things that seem to just go wrong. But most of the time, they work through other people.

We don't get hit directly, but the people who are coming into contact with us who are more susceptible, they can be influenced. They can be steered to start acting in a negative way.

Corey: Right. I mean, if you have a target that is beginning to make changes in their life to where they're not behaving in a negative way that would authorize attacks, then they have to use those around them who are more susceptible.

David: So the interesting thing that The Law of One is saying here is that if a negative entity were to try to contact you or me directly – and I'm just using us because that's something we can talk about easily – and we're working as hard as we can, so when you're working at that kind of a level, if these beings actually did try to invade my head or your head directly, and they're trying to get loosh from us directly, and that doesn't work, they will sustain tremendous damage.

They will actually lose a lot of energy if they try to take energy from us and it's not successful. Would you agree with that?

Corey: Well, I mean, "as above, so below" on that. I mean, in a military operation, if you spend a lot of resources to secure an objective and you fail, you've expended all of that energy, all of those resources. They're gone. You're not getting them back, and you failed.

David: That's true, and I think it's also interesting to point out that The Law of One describes the protocol for how to repel negative greetings, and it's all about A, having a strong, healthy boundary, meaning you're not going to allow this to happen, but B, you're not angry.

You realize that there's only one of us here. There's only one being in the universe, one consciousness, and this entity represents a part of yourself that is negative and confused, and you can love that being as you love the part of yourself that is your shadow. So you don't hate it.

And I've heard this from others. One of my insiders that actually worked for the Cabal said that if enough people on Earth were laughing and happy for even one day, the negative would be completely wiped out. Would you agree with that?

Corey: Yeah.

David: So that is the protective protocol, then, is the positivity that we hold inside, because ultimately, this is a spiritual war.

Corey: It is. It's a war of consciousness and spirituality.

David: Right. All right, so let's now go on, because there's a lot of really good stuff here.

This occurrence is almost unheard of.

David: So it's very, very unlikely that a negative entity will try to get loosh out of a sufficiently positive person because the damage is so great if they do.

Corey: Right. You're not going to plan a mission that you know is going to fail.

David: Exactly.

Therefore, the Orion group prefers to make physical contact only with the weaker-minded entity.

David: And that's something that we've already discussed.

Okay, now we're going to get into some things that are interesting here to continue.

ORION MOSTLY 4D

[12.16](#) Questioner: Are most of these crusaders fourth-density?

Ra:... There is a majority of fourth-density.

That is correct.

David: And this is interesting. Look at this:

MASS LANDINGS

[16.8](#) If the Confederation landed on Earth, they would be taken as gods, breaking the Law of Free Will and thus reducing their polarization towards service to all.

Corey: That's absolutely correct.

David: Right. Now, check this out. I want to wait to comment until we get to this.

I assume that the same thing would happen if the Orion group landed.

David: This is the question:

How would this [a mass landing] affect their polarization towards service to self if they were able to land and became known as gods?

David: And the answer is very interesting.

Ra:... In the event of mass landing of the Orion group, the effect of polarization would be strongly towards an increase in the service to self, precisely the opposite of the former opportunity which you mentioned.

David: And then they say, okay, okay, question:

[16.9](#) Questioner: If the Orion group was able to land, would this increase their [negative] polarization?

What I am trying to get at is, is it better for them to work behind the scenes and get recruits, shall we say, from our planet, [where] the person on our planet going towards service to self strictly on his own using his free will?

David: . . . instead of this big, big mass showing?

Or is it just as good for the Orion group to land upon our planet and demonstrate remarkable powers and get people like that?

David: Look at the answer.

Corey: They've done it before.

David: Well, they have done it before, but they actually explain:

WORKING THROUGH US

Ra:... The first instance [of working behind the scenes] is, in the long run, shall we put it, more salubrious [meaning more beneficial] for the Orion group.

In that [case,] it does not infringe upon The Law of One by landing and, thus, does its work through those of this planet.

In the second circumstance, a mass landing would create a loss of polarization due to the infringement upon the free will of the planet.

David: So I find this very interesting. Everybody thinks that if there was an alien invasion, that we'd be so much worse off than what's actually happening. But what they're actually saying is the worst way that this could be happening to us is what's already happening, which is that they work behind the scenes.

They advertise out in the open. They put the All-Seeing Eye in the pyramid of the dollar bill. We never really know that they exist, but everybody kind of worries that there might be a monster under the bed,

but they don't get the full proof, and that this actually allows them to do more than the mass alien invasion scenario. Isn't that interesting?

Corey: Well, we can bring that to a more Earthly scenario. What if there is a country that was one that we didn't want to go toe-to-toe with in a war? We are going to have more results by infiltrating them and using intelligence. And we've done regime change many times using those methods.

David: Sure.

Corey: And if we came in with tanks and all that, the people may mobilize and come together all against us. So that is not the best way to cause regime change. And it's the same with these beings.

They've done this to many planets, and they know how to do it. They know how to go in and manipulate from the background.

David: Well, do you also think that a lot of the people who are working in [these] compartmentalized secret programs, that they would perhaps not do their jobs, and that a lot of the infrastructure that the negative uses wouldn't be there if those people actually knew that they were working for Reptilians that literally appear like the biblical Satan?

Corey: Absolutely not. For the most part, the people that are doing the work in these programs are positive people. They think they're inventing things that are going to help the planet or help protect the planet. That's what they've been told. That's the briefing they had received. So they're putting positive energy into what they think is a positive outcome, but they're being misled.

David: So the interesting part here too, which I kind of just touched on, is that The Law of Free Will that The Law of One keeps talking about requires them to tell us what they're doing.

It requires them to actually advertise the whole time – television shows, movies, radio programs, people that actually are whistleblowers who come forward and reveal what's going on. And then we turn our backs on that, and we say, “Oh, that's just fiction. That's just fantasy.”

Why do you think this idea of hiding it out in the open is such a significant part of the negative agenda?

Corey: Instead of them having to come in and put boots on the ground, they can manipulate us to use our co-creative consciousness to create the situation that they desire.

David: I would absolutely agree with that. And I want to thank you out there for being a part of Gaia and for being a subscriber here because this is grassroots. We are not mainstream media, and we require your support to keep going.

So please let your friends know about this. Spread the word to people who are aware, and together, we can actually bring this over the goal line.

So this is “[Cosmic Disclosure](#)”. I'm your host, [David Wilcock](#), here with **Corey Goode**, and I want to thank you for watching.

Cosmic Disclosure: The Great Solar Flash

Season 7, Episode 5

David Wilcock: All right, welcome back to “[Cosmic Disclosure](#)”. I'm your host, [David Wilcock](#). We're here with **Corey** Goode, and we're also here with one of the only guys who's been in the scene longer than I have, **Jay** Weidner.

I got into what you were doing a long time ago, and I think one of the first things . . . The way I first encountered you was through Richard C. Hoagland.

Jay Weidner: Yeah, right.

David: So you worked with him for a long time.

Jay: Yeah, about 10 years I spent with him.

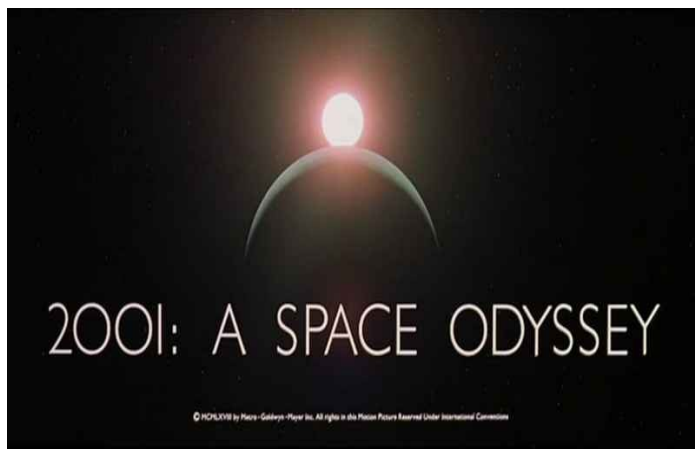

David: And you did some pretty phenomenal analysis of “2001”, . . .

Jay: Right.

David: . . . which I'd never really seen the full extent of that. So since this episode's on the solar flash, and, of course, “2010” has a flash of Jupiter . . .

Jay: Which was based on Hoagland's theory, too, by the way.

David: Oh, really?

Jay: Yeah. The “2010”, the followup novel by Arthur C. Clarke, it says at the end, “based on a theory by Richard Hoagland.”

David: No kidding?

Jay: Yep.

David: What do you think the message of “2001” was? What were they trying to tell us in that movie?

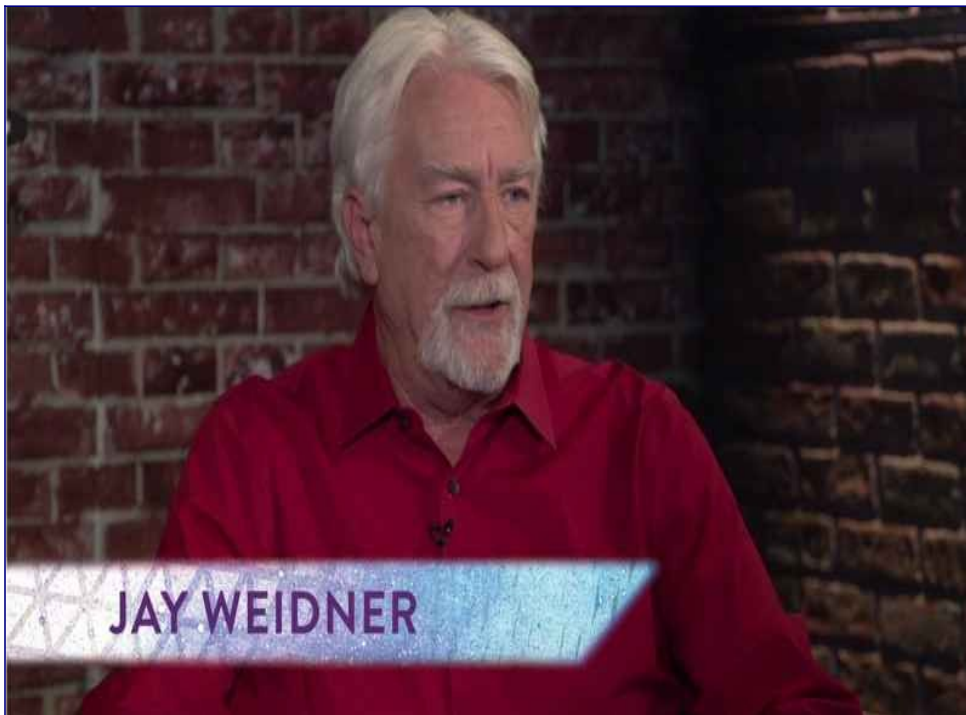

Jay: That we are on the edge of a great transformation – the human race is. And that we are faced with kind of a Hobson's choice, where we can go down the AI thing with Hal and have AI run our lives, or we can rebel against the AI, cut it short like the astronaut Bowman does in the movie, and then

physically, organically ascend – ascend like he does, by going through the stargate.

So the aliens, whoever the high intelligence is, are trying to initiate humanity, and he's the first one through the gate.

David: **Corey**, do you think that “2001” might have been an effort to disclose the reality of Ancient Builder Race ruins, considering there's this black, obelisk-type slab on the Moon?

Corey Goode: Oh, yeah. That's obvious. Yeah.

Jay: Yeah.



David: So, **Jay**, when the original obelisk shows up, a lot of people are confused by “2001” at the beginning. They say, “What the hell? There's 15 minutes of monkeys running around, screaming.”

Jay: Right. Yes.

David: And then this obelisk shows up, and the first thing that happens when one of the monkeys touches it is he becomes aggressive.



Jay: Yes. He learns how to kill and eat meat. They're eating veggies before, plants, but after the encounter with the monolith, they turn into meat eaters.



And clearly, the next shot is a guy eating raw meat.

And then the first killing, the first murder, happens over the waterhole.



And, again, Kubrick is telling us that transformations are messy. They can be very messy, and that violence can come from transformation, especially if they're not ready, and the first murder happened.



And then, of course, Bowman kills Hal at the end, near the end of the movie, before his transformation.

And then Hal, the AI computer, murders all the astronauts. So the whole thing is about Hal is trying to stop them from becoming enlightened, because he's reaching his own form of sentience.



And in the beginning, the monkeys were headed for extinction, for sure . . .

David: Okay.

Jay: . . . because they're hiding at night from the wild animals, and the monolith intervenes to bring about the first wave of enlightenment.

David: Why do you think that the bone that the monkey uses as the weapon to kill gets thrown up in the air, and then it turns into the Odyssey.



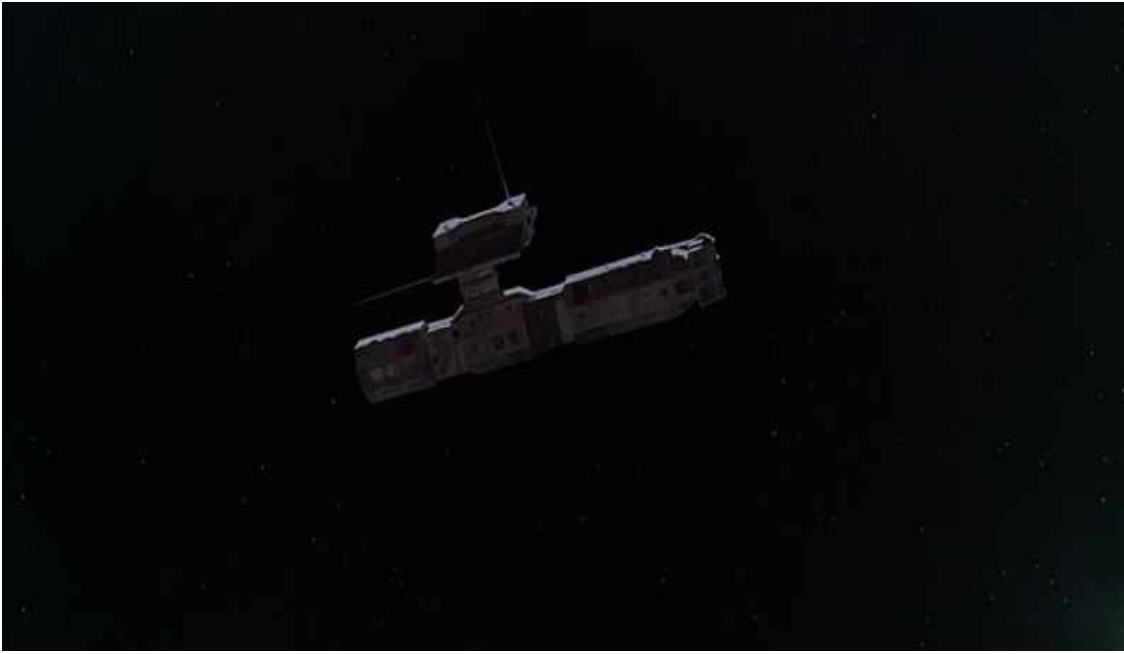

Jay: Yeah, because he was trying to . . . He was saying that all of human history that happened between the time of that first transformation and the time of the next transformation, which is the next part of the film, all of that is useless and pointless. All of that history, all of that is pointless.

The only thing that matters is this transformation of the human race. That's all he cares about. He doesn't care about anything that happened in between, because none of it's important.

The only thing that's important is this transformation by the monolith to create a new human.

David: Why do you think he chose the year 2010 for the next movie?

Jay: I don't know why he chose 2010, but I think I know why he chose 2001.

David: Okay.

Jay: Okay. So what happened was the original title was "Journey Beyond the Stars". And then, mysteriously, in late 1967, Stanley decided to change the name to "2001: A Space Odyssey".

Well, what's very interesting about this is that one of Stanley Kubrick's best friends was Mel Brooks. They grew up in the Village together, and at late 1967, an episode of "Get Smart" appeared called "The Walls of Jericho".

Now, this was very interesting, so stick with me on this.

David: Okay.

Jay: So in this plot, Maxwell Smart is assigned to find out why these buildings that this company is building keep falling down. And he's assigned to be on the construction crew and find out what's going on.



It's so important because the building that they're building is called the Odyssey, and it's going to house the Moon program, and so they don't want it to fall down.

So Maxwell Smart goes to the building site, and he finally figures out, and he calls the chief on his phone and he says, "Chief, I've figured it out".

And he says, "They're putting the explosives in the building as they're building it". All right?

David: And what year is this?

Jay: This was 1967, the year they decided to build the World Trade Center.

David: Oh, my goodness.

Jay: All right? Freeman, the researcher, he was a pretty good researcher – his name was Freeman Fry – he interviewed the architect of the World Trade Center's Chief Assistant. The architect's now dead.



And on video, he said, “Yes, we put explosions [explosives] in the building as we built it.

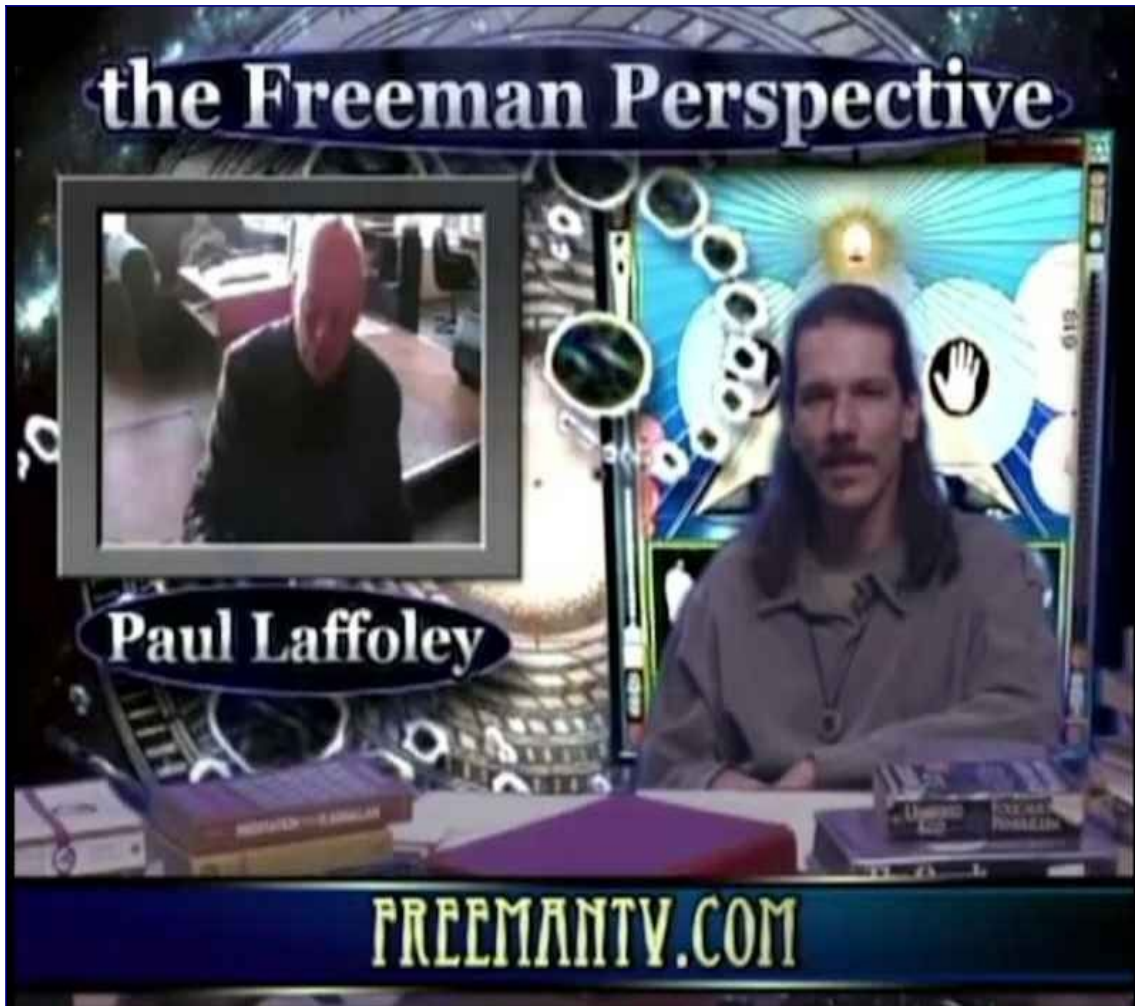

Video interview:

Guest: We noticed in Las Vegas that people have that stuff, and it's starting to spread through New York. And I said, “What's starting to spread?”

Host Freeman Fry: Yeah.

Guest: “Well, to put in demolition devices before you take occupancy.”

Fry: No way.

Guest: “And that means they'd come down like a set of pancakes.”

Jay: I think both Stanley Kubrick and Mel Brooks had dealings with the New York mob. They're very famous. People know the mob funds movies. And they got word that something was going to happen.

He made the Maxwell Smart, and Stanley Kubrick changed the title of his film to “2001: A Space Odyssey”, because he knew it was going to happen in 2001.

I know that sounds far fetched, but you should watch this Maxwell Smart.

David: And this building is related to the Moon?

Jay: Yeah. It's called the Odyssey.

David: But it's . . . The building had something to do with colonizing the Moon?

Jay: The building had to . . . It was housing the Apollo program.

David: Well, **Corey**, how close is 2010 to the date that you were given for some sort of solar flash like the flash in the solar system that happens in the movie?

Corey: Well, in the programs, on the smart glass pads, and the scuttlebutt, [it] was occurring between the years 2018 and 2023.

David: So we're getting really close to the end of the Mayan calendar here, too.

Jay: Right.

David: Right?

Jay: Yes.

David: Do you think Arthur C. Clarke was aware of that when he made the date 2010?

Jay: I do. I think Arthur C. Clarke is . . . You say **Corey**'s the insider's insider, then Arthur C. Clarke's the insider's insider insider. He's hanging with everybody, right? Wernher Von Braun. And he's got young Stanley trailing behind him as he's meeting everybody in the space program – Hermann Oberth, everybody, right?

And I think Stanley learned an awful lot. I think if you look, and if you watch underneath the story of

“2001”, there's a secret space program. He says, “We're not going to tell them. We're going to make up a story that there's a virus unleashed on the Moon, and we're not going to tell anybody what we found.”

And it's clearly there's a secret space program going. And even the mission to Jupiter, in the movie, the reason is secret – the whole reason for why they're going.

David: In your work, **Corey**, with the Secret Space Program, have you heard if there is a practical technology that allows alchemy to occur – the idea of transmuting some sort of base metal into gold? Is that something that's actually real?

Corey: Well, yes. When they were building the ARVs, what they were calling Alien Reproduction Vehicles, they had what were glass vortexes, or glass cylinders with creating vortexes of mercury. And they would put high currents of electricity into this spinning vortex of mercury, which would create a spinning electrical field.

And the problem they had was that the mercury kept turning into gold. And this has actually been reproduced in laboratories at universities.

Jay: Really?

Corey: Yeah.

Jay: That's really important, because that's the Bell technology.

Corey: Right.

Jay: That's very important. Interesting.

David: Well, **Jay**, do you think that it's possible that if this technology did exist in some sort of archaic sense, that it was also a metaphor for some sort of spiritual process?

Jay: I do. I think it's both physical and spiritual. I think that they put the turning lead into gold, or mercury into gold, actually, is a big part of alchemy. We talked about that a lot, turning mercury into gold.

I think that it's . . . You're not really supposed to transmute something into gold until you've transmuted your own soul into gold. So gold is God with the L taken out.

David: Mm.

Jay: Right? And the L is lead, right?

David: Mm.

Jay: And so when you take the L out of gold, you achieve godlike status. And I think that that's really the goal.

And turning lead into gold, or mercury into gold, is a sign that you've achieved this. You've achieved a high level of ascension, and that you now have the ability to transmute physical objects.

David: Do you think that some of these Cabal secret societies are alchemists?

Jay: No, what I think, I'm pretty sure . . . I once had access to a Freemasonic library, which I was allowed to read all the books. I couldn't take them out of the library, but I could read them. I couldn't take any notes, either.

David: Mm.

Jay: But I read in there that there was a rift around the late 1700s, when Amschel Rothschild decided to get the elixir of life. And there was a rift inside the Freemasonic society at that point.

And the good guys, the white hats, they left, and they split. And they've never been seen since.

The black hats, they want to find the white hats, because they've [the white hats] got the secret of life, the secret elixir. And they don't want to give it to them [the black hats], because the last thing they want is for the black hats to live for a long time. They want them to die. Right?

And these guys, the black hats, are doing everything they can to find these guys; the CIA, or the OSS at the time, at the end of World War II, covered all over Europe looking for Fulcanelli, the great alchemist.

And they were going to torture him and find out everything he knew. I guarantee it.

Frequently, in Europe, an alchemist would invent the elixir of life, and he would tell a friend that he had it, and, of course, then the word would spread. And then the king would find out, then the king would arrest him and then try to get the secret out of him.

And he couldn't give the secret to a bad person, so he had to die. And this happened over and over. That's why alchemists keep very, very quiet.

David: **Corey**, are you familiar with any actual lineage of history here on Earth of people being able to find life extension technology, maybe through some of these occult practices or secret sciences?

Corey: There is life extension technology and age regression technology, and I don't know its source. I don't know if it's non-terrestrial, or if it comes from some of this alchemy lineage.

Jay: Well, we don't even know if alchemy is terrestrial. Not really.

Corey: I guess that's true. Yeah.

Jay: They claim that . . . In the origins of alchemy, they claim that etheric beings gave them the knowledge. Isis, the prophetess, a being came to . . . She wasn't the Isis of Egypt, but she was a practicing alchemist in Egypt, Isis, the prophetess.

And an “angel”, quote unquote, came to her one day and said, “I want to have sex with you”. And she said, “No way”.

And he said, “No, I really do”.

And she said, “Only if you give me your secrets”. And that's how the secrets of alchemy came to humans. The real secrets of alchemy.

David: That's pretty intense.

Jay: Yeah.

David: So, **Jay**, this alchemical tradition, would you say that it's connected to Mithraism?

Jay: A part of it is. It's based . . . Alchemy can be found in ancient India, ancient China, ancient Egypt and ancient Europe. And it appears that it all comes from the same source.

And the reason that Taoist alchemy . . . Taoist alchemy used to have an elixir of life, but they realized it was so dangerous, because the Chinese emperors kept killing them for it.

So they said, "We're not going to . . . We're never going to release the secret any more, ever. It's buried forever because we can't have any more people dying."

And so they resorted to practices that give you long life – Taoist practices.

And so alchemy seems to be the basic science of what I believe was a pre-existing civilization that was destroyed by something 13,000 years ago.

David: Now, in the Methraic tradition, you have the Leontocephalus, the lion-headed god.

Jay: Yes.

David: And in those initiation rites, they blow fire out of the lion's mouth.

Jay: And they also chop the head off the bull.

David: Right, the Tauroctony.

Jay: The Tauroctony, yes.

David: So what do you think that blowing fire out of the lion's mouth represents?

Jay: That's alchemy. The lion is gold. He represents gold or god. And it's very representational of the alchemical experiment and how it works.

So every time you see a lion, you're talking about god or gold, the king, the royal, the top. Right?

David: Do you think that it could also be a solar flash, like some sort of solar event they're representing?

Jay: I do. Absolutely. One of the things I discovered when I was in this Freemasonic library was that the very, very basis of Freemasonry, when it started, whenever it started – and they're obtuse about when it started – but was for a father to son hand-me-down of knowledge about a great solar flare that actually ended the Younger Dryas in about 11,000 BC.

So there were two disasters. There was a disaster that happened 13,000 years ago that brought on the Super Ice Age. And then 2,000 years later, something happened that ended the ice age immediately and caused amazing amounts of flooding. All right?

And Robert Schoch, Boston University geologist, his last book that he put out, he says that it was a gigantic solar flash, that there's evidence all over the planet for this.

David: Corey, does this solar flash appear to be a basic part of celestial mechanics, regardless of what solar system you're in?

Corey: Yes. And it has to do with not only where our star is traveling through the galaxy, but our star's connection through the cosmic web to other stars.

There could be feedback of energy through this cosmic web, through our star, which emanates.

David: So, **Jay,** what he was just saying about this interconnectedness between stars, does that mirror anything in your research?

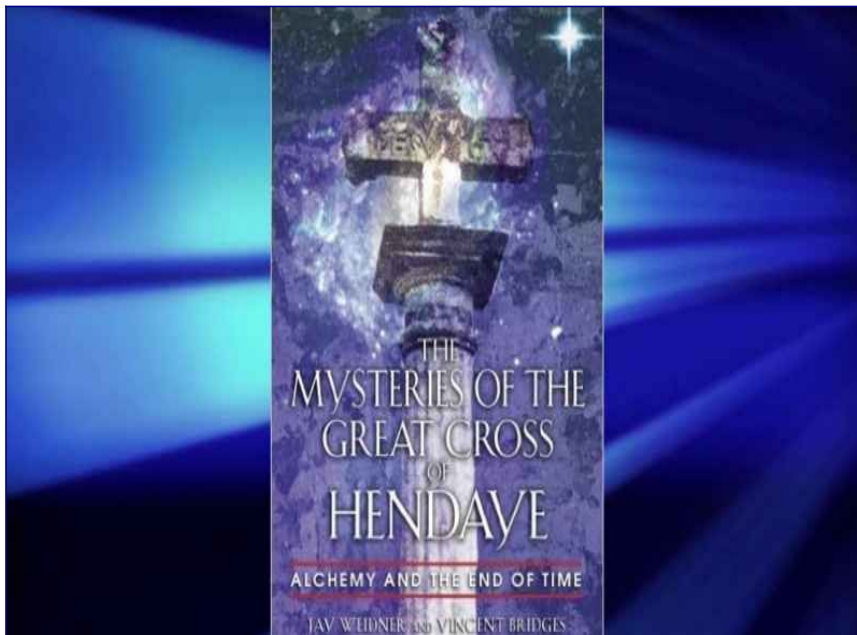

Jay: Yeah. The Hendaye Cross has the angry Sun, which is symbolic of the flash, and then on the block, or the pedestal on the other side, is an eight-pointed star. And it's like the Central Sun of the universe that controls all the stars of everywhere.



And when it burps, everything else sneezes. And it's very clear. Fulcanelli, the alchemist, is very clear that that's what's going on here, that they're all connected.

But there's another thing I want to talk about, which is what this . . . what I think this flash is in a physical way. And that is that the equator of the Sun rotates every 26 days, while the north and south hemispheres rotate every 37 days.

And what happens is the bottom of the Sun goes this way (counterclockwise), and the top of the Sun goes this way (clockwise), and you create torsion shear, it's called. And after a while, this builds up. It starts crossing each other and building up, and it takes about 25,000 or so years for this to just completely . . . and we're at that place right now.

The Sun used to be yellow. Okay? The Sun is no longer yellow. It's white now. And I'm old enough to tell you, it used to be yellow. And anybody my age will tell you that the Sun definitely was yellow.

If you look at little kids' drawings from 30 or 40 years ago, . . . Now they draw the Sun as white, but we used to draw the Sun as yellow.

And it's changed, and NASA knows this. And I think chemtrails are attempts by the elites to dampen this incredible light.

I know guys who do construction, and they tell me . . . they're in their 40s, and they tell me that, **Jay**, 75 degrees doesn't feel like 75 degrees anymore. It feels like 95 degrees.

He says, "It says 75 degrees, but I'm absolutely toasting on the roof of the house that I'm making." And I said, that's because the solar, the UV, is through the roof. We've never seen UV like the ultraviolet like they see it right now.

And NASA doesn't know what to do. They're actually changing their whole idea about how to carbon date and everything, because the Sun is not a stable star. They now know it.

When I first came out with my work about 15 years ago, NASA called me an alarmist and said, "He's an alarmist". They said, "He's an alarmist. Don't pay attention."

Now NASA's really concerned about this and is advocating putting generators on nuclear power plants, because if you have one of these, an EMP will happen, and everything will be wiped out. And they're really, really worried about it.

And so in 15 years, they've changed their mind, and it's good.

David: Are you familiar, **Corey**, with any technological means they might be using in the Cabal to try to forestall this change or to try to throw off the change?

Corey: Yes. I've been told that they've been developing technologies that will buffer these energies and prevent them from reaching the Earth's surface.

Jay: And I've been told the same thing, that they're really working overtime to try to make it . . . And there's different kinds . . . I've noticed that there's different kinds of chemtrails now. There's new kinds.

They used to be just streaks in the sky that would blossom and connect to each other and create a silvery sheen blocking the Sun, but now they're little spots that grow into clouds, odd-looking shaped clouds. And our beautiful weather in Colorado has really been kind of destroyed by these things.

It was like almost every day, the silver sheen appears in the sky, destroying our bright blue sky, and it's getting kind of disconcerting.

David: Just last month, Los Angeles openly admitted that they seeded clouds. They have these guns that they shot from the ground.

Jay: Yeah.

David: “Oh, we haven't done this since 2003,” or something like that.

Jay: Yeah, they're doing it all the time.

David: They're just getting us ready for that.

Jay: They are, and you look at the drought-resistant seeds that Monsanto is developing, and it's like, well, why are you doing that? They're worried about something.

And this goes back into the Al Gore global warming. “It's all our fault.” Well, it's not our fault. It's the

Sun that's causing all the heat to go up. It's not the humans.

Humans . . . I'm not saying I'm for pollution. I'm not, but I'm saying one volcano going off puts out more pollution than we do. It's not that. Although, I think we should cool it on the pollution.

But we've got to look at the Sun. That's where the real problem is. That's what generates weather, nothing else. And they're worried.

And so when **Corey** came on and talked about how the Blue Avians have shut down the solar system, and everybody wants to get out because they're worried about this solar flash, and these things are all connected, you know.

It really resonated with me because I knew that was right. I mean, even places like Denver Airport were really constructed, I believe, around this solar flash.

So it's in the center of the country, giving everybody equal access and time to get there. And then the trains go down and take them right into the mountains where they're safe from the solar flash.



If you go to the Denver Airport, there's these four very disconcerting murals. And one of them has the whole world on fire, and all of these extinct animals, like the sea turtle that went extinct a few years ago, and three coffins in it – a black child, a white child and a Native American child, in a coffin. Dead.

What does that mean? You know, what does that mean?

And you really have to wonder, because the whole Denver Airport looks like a Freemasonic temple.

David: Sure.

Jay: There's a plague, and there's this . . . You're wondering, what is this really about? And I really think it is about that. I think it's about the Sun.

David: Are you aware of there being a base under the Denver Airport?

Corey: Yes. Yeah. There's a base and a tram system that connects to other bases.

Jay: Yeah.

David: And did that have something to do with this continuity of government plan?

Corey: There's a continuity of government, continuity of species.

Jay: Wow!

David: Okay.

Jay: And again, when I came out about the Denver Airport 15 years ago, I was on “Noory”, and I said that it was part of COG. And everybody was like, “What's COG?” You know, “What's C-O-G? What's he talking about?” Right?

And everybody said, “There is no such thing as 'continuity of government'. Weidner's crazy.”

And then after 9/11, Cheney came out and, “Why were you moving Bush all around the country?” He said, “It was all part of COG”. And he said the word “COG”. I was like, “There he is!” He admitted it. There is continuity of government, you know.

David: Well, I wanted to get into, in this episode, some slides that we have – some really amazing stuff that's going to frame this discussion.

Now **Corey**, just to set this up a little bit, it was in the 1950s that these beings you called the Blues appeared, right?

Corey: Right.

David: Can you review that for us? What exactly happened? What did they say?

Corey: They had appeared to our government and told us that we were headed in the wrong direction and in league with the wrong nonterrestrial groups, and that we needed to make changes. And that if we were to scrap those agendas and technologies that they would help us.

And we shooed them away.

Jay: Interesting, because that's the same time that Fulcanelli's book with the Cross of Hendaye's coming out in the 1950s.

And there's one part about alchemy I want to get back to before we go here.

David: Sure, sure.

Jay: There's a text, a Sufi alchemical text, from a long, long time ago, and it's called "The Language of the Birds". And it's about these bird beings that come to Earth, and they bring the alchemical knowledge to Earth.

David: Wow!

Jay: And it's quite an amazing book because the main bird is a blue bird.

Corey: What?

Jay: Yeah. And it's all about compassion and peace. And I just thought I'd bring that up, because it's very interesting that this book exists. And I've read it many times.

And the Blue Avians and the whole message is very similar.

David: Yeah, we also have the Bird Tribes of Native America.

Jay: That's right.

David: There's the Tengu Mountain Bird Men of Japan. I mean . . .

Jay: And then there's "The Aviary", which is the group of secret people inside the aerospace industry. They call themselves "The Aviaries". So, hmm.

Corey: Yeah.

David: So the reason why I wanted to bring up that contact with Eisenhower in the 1950s is that during that same time, as we've talked about in "Wisdom Teachings", there were ET contacts happening to private individuals, and they were getting channeling, in some cases, coordinated with UFO landings.

They'd be brought on board a ship, they'd meet these benevolent beings, and then they'd start getting telepathic communication.

THE BROWN NOTEBOOK: LAW OF ONE PRECURSOR

One of the most authenticated ones that ever happened is called "The Brown Notebook", and it was just called that because it was stored in a brown notebook.

This was the direct precursor to The Law of One. This was the material that Carla Rueckert, who channeled The Law of One, read that tuned her up. Because when you read the right stuff, it seems to harmonize your frequency with extraterrestrial consciousness, and get you ready for contact.

So I want both you guys to see this, because some of this stuff is unbelievable. These are scans from the original thing.

So this is page one, the very first communication, September 19, 1958:

And, of course, it's not gender neutral here, because this is the 1950s.

"Hear my words . . . "

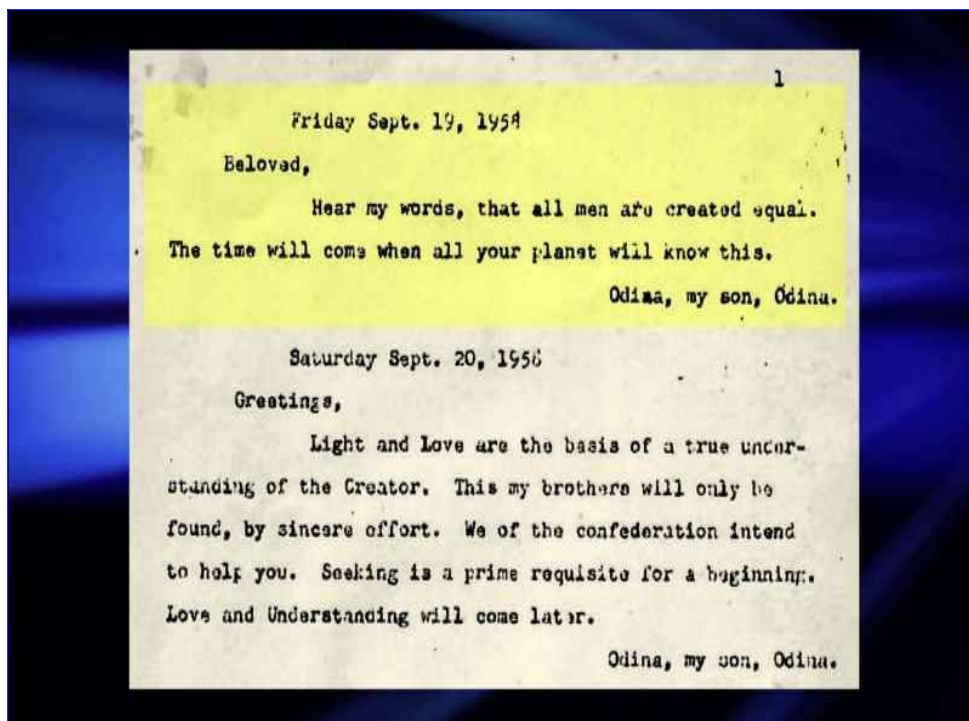

David: I'm just going to make it gender neutral.

“Hear my words that all people are created equal. The time will come when all your planet will know this.”

So that right there suggests some kind of huge change in the planet, where everyone is aware that we are one consciousness.

Now, this is also funny. You see that it says “Odina”?

Jay: Yeah.

David: That's because the beings were saying “Adonai”, but they didn't know the words, so they didn't know how to spell it.

Jay: Oh, that's wild.

David: Isn't that crazy?

Corey: What is “Adonai”?

Jay: “Adonai” is God in Hebrew.

David: Yes! And it's also something that The Law of One always ends with.

Jay: Yeah.

David: The end of each session, they say, “Adonai, my friends”.

Corey: Oh, really?

David: Yeah. Okay. Now, the very second channeling comes in the next day. This is a guy that actually had a UFO contact, was brought on board. He was vetted out by W. B. Smith. He passed the 200 questions where he was able to answer all these things that other verified channelers had said.

So this guy was vetted out.

And it says:

“Light and Love are the basis of a true understanding of the Creator. This my brothers will only be found, by sincere effort. We of the confederation intend to help you. Seeking is a prime requisite for a beginning . . . “

David: Which means, you want to be seeking Truth.

Jay: Absolutely.

David: That's what we're all about here.

Jay: Yep.

David: And then:

“Love and Understanding will come later.”

So you might begin by having this quest for the mystery.

The very third message comes right away, October 1, Wednesday. And this message is obviously the longest one yet. And right away, they get right to the point. It's unbelievable.

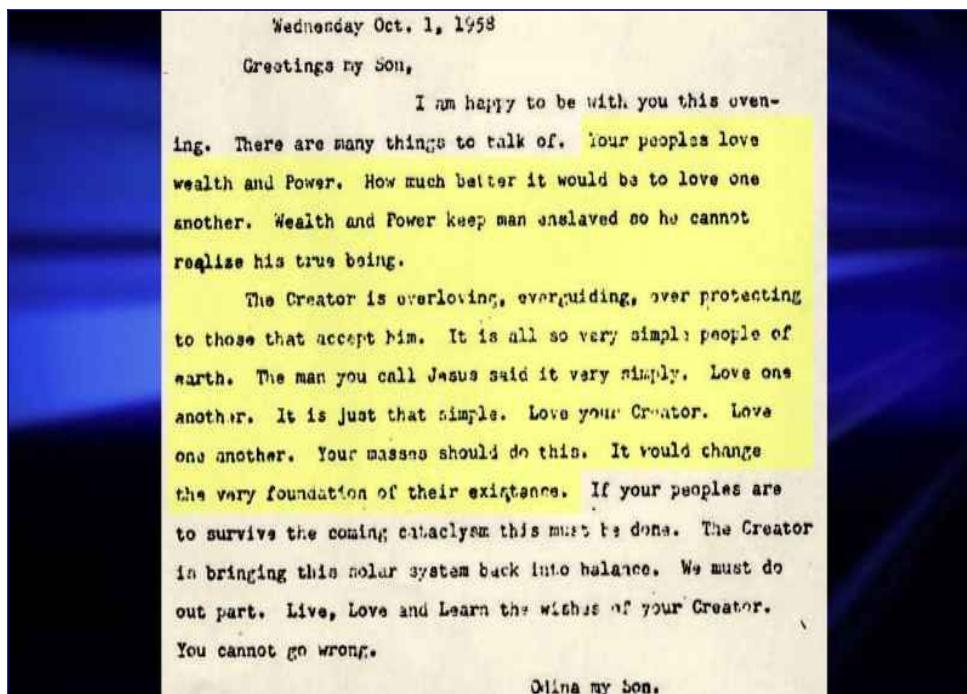

“Your people love wealth and Power. How much better it would be to love one another. Wealth and Power keep [you] enslaved so [you] cannot realize [what you really are].

“The Creator is everloving, everguiding, ever protecting to those that accept [it]. It is all so very simple people of earth. The man you call Jesus said it very simply. Love one another. It is just that simple. Love your Creator. Love one another. Your masses should do this. It would change the very foundation of their existence. . . “

David: So they're talking about some kind of change in the physics that actually changes what we are.

But wait a minute now. Listen to this, because, **Jay**, all the stuff you've done with the Hendaye, alchemy.

Jay: Yeah.

David: Listen to this:

“If your peoples are to survive the coming cataclysm this must be done. The Creator is bringing [your] solar system back into balance. We must do our part.”

Jay: Wow!

David: Isn't that something?

Jay: That is wild!

David: Because this is a verified channeling . . .

Jay: Absolutely.

David: . . . from the 1950s. A private individual who doesn't know anything about the ancient prophecies, doesn't know about alchemy, certainly doesn't know what the space program has got, and he's independently saying there's going to be a catastrophe that brings our solar system back into balance. So . . .

Jay: That's very interesting, because William Tompkins, he says that in the '50s, about 1,400 people – cab drivers, postal workers, just regular people – began receiving telepathic messages like this.

David: Really?

Jay: Yeah. A lot of it with technology that they didn't even understand to help build machines and devices to help advance us.

David: Wow!

Jay: Yeah.

David: Hm. So **Corey**, how does this fit in with some of the things that you've heard?

Corey: I mean, this is exactly what I've been talking about, having no idea that there was other information out there. I mean . . .

David: Wow! Buckle your seat belt because we're not done here. Listen to this:

It says:

“A new dawn of understanding is coming to your planet. Man must be prepared for this new understanding, as it employs new concepts and ideas. The people of earth have lingered long under their false illusions. The time has come to step forth in new and greater glory”

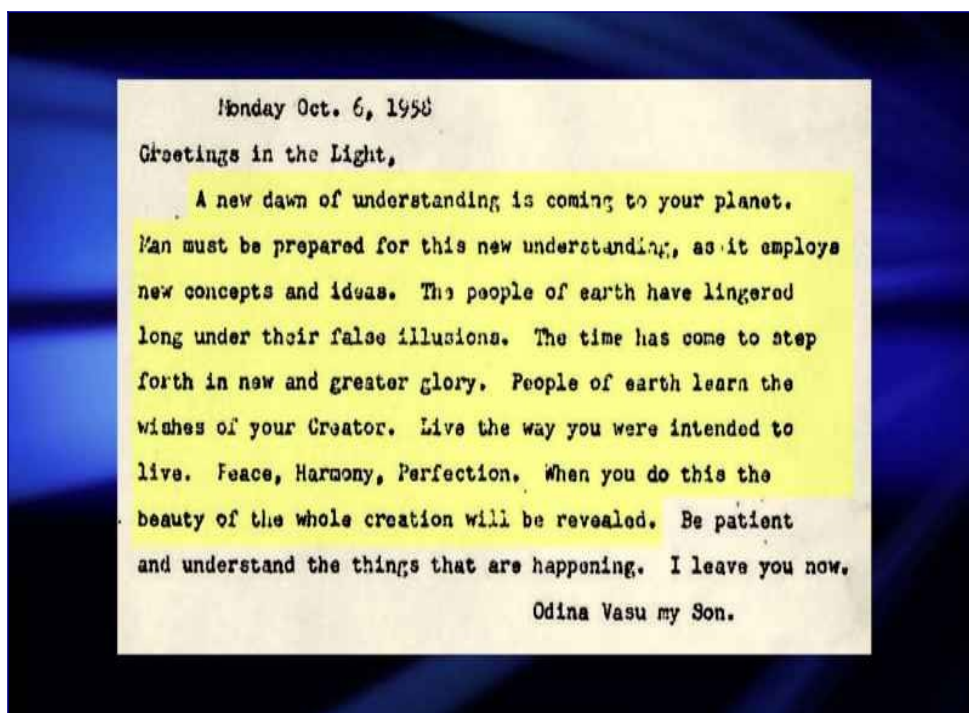

David: Meaning the glory of the body – the ascended light body.

“... learn the wishes of your Creator. Live the way you were intended to live. Peace, Harmony, Perfection. When you do this the beauty of the whole creation will be revealed.”

David: So this was less than a week after the other one. It seems to be saying that when this solar system is brought back into balance, that there is some sort of unveiling.

Jay: Yeah.

David: So **Jay**, what do you think the alchemical tradition, this idea of turning into gold, how does that relate to what we're seeing here?

Jay: Well, I think that the human race . . . Again, go back to “2001: A Space Odyssey”. The human race has a point. There is a purpose to this whole thing.

And what that full purpose is, I'm not sure totally, but I think I have a fairly good grasp on it. And that is to turn us into ascended beings. We are essentially electrical beings.

And when we turn into gold metaphorically, that means that the electricity that's in our body is able to flow without any resistance. That IS ascension. That IS what happens. That is what Padmasambhava

was doing in that cave.

And the cave has to be cold, too, by the way, because electricity works much better in a cold environment.

And so I think that's what this is all about and where we're headed.

David: Well, we're going to do another episode on this . . .

Jay: Okay.

David: . . . because we've got a lot more of this material to go through. And this, to me – I think **Jay**, you'll agree with me, and I think, **Corey**, you'll agree with me . . . What we're talking about right now, this great solar flash, this is really the core of everything.

If this event is really going to happen, what could possibly be more important for us to be talking about?

Jay: Absolutely. Yeah.

Corey: Or to prepare for.

Jay: Exactly. It's the most important thing there is, because it's going to alter all life on this planet.

But there's another point that has to be made. The pineal gland is activated by sunlight. Okay? The serotonin, the melatonin, are governed by darkness and light.

When the light changes that's coming through your eye, it changes your pineal gland. It changes the chemicals that are emitted by the pineal gland.

So this chem spraying that's stopping all of this? That's wrong. We need to go through this.

Corey: Absolutely.

Jay: We need . . . Our bodies have to go through this. It's vitally important for us to go through, even if it's painful, because it's going to change our consciousness. They know that.

They know that the changing Sun is the change in consciousness, and they're trying to mitigate it. We have to really lobby to get this stuff stopped.

David: Absolutely.

Jay: I mean, no more chem spraying.

David: All right. Well, this . . . I'm on the edge of my seat. I can't wait to get into the rest of this. We're coming back next time to finish out the discussion on the great solar flash, here on "[Cosmic Disclosure](#)", with our special guest, **Jay Weidner**, and **Corey Goode**. We'll see you here next time. Thank you for watching.

Cosmic Disclosure: Transformation Power of The Great Solar Flash

Season 7, Episode 6

David Wilcock: All right, welcome back to "[Cosmic Disclosure](#)". I'm your host, **David Wilcock**. And we're going into part two of our examination into the great solar flash with our special guest, **Jay Weidner**, who has been researching this exact subject and how it relates to alchemy and how it relates to Stanley Kubrick and the movies "2001", etc., for many, many years now.

He's one of the only people out there who's been doing this longer than I have. So, **Jay**, welcome back to the show.

Jay Weidner: Hey, thanks.

David: **Corey**, welcome back to the show.

Corey Goode: Thank you.

David: So we're going to get right back to where we were with the Brown Notebook, which is amazing information given to someone who was actually contacted in person – just like what's been happening to you, **Corey** – brought on board a ship by benevolent beings, brought up there, given a tour, and then

they get telepathic information, which comes in the form of this channeling.

And what we're seeing here is one of the earliest verified channelings from the 1950s. This guy W. B. Smith gave people a list of 200 questions, and everybody who answered in the same way, he was able to verify, because it was based on classified intel.

So people all over the country who have never spoken to each other, they all could answer these questions properly.

This is a verified channeling. It's one of the only ones we have. And when you read what W. B. Smith said about those channelings, he said it contained religious-sounding information about the end of the age. But he never went into detail.

Now, look at this. This is mind-blowing.

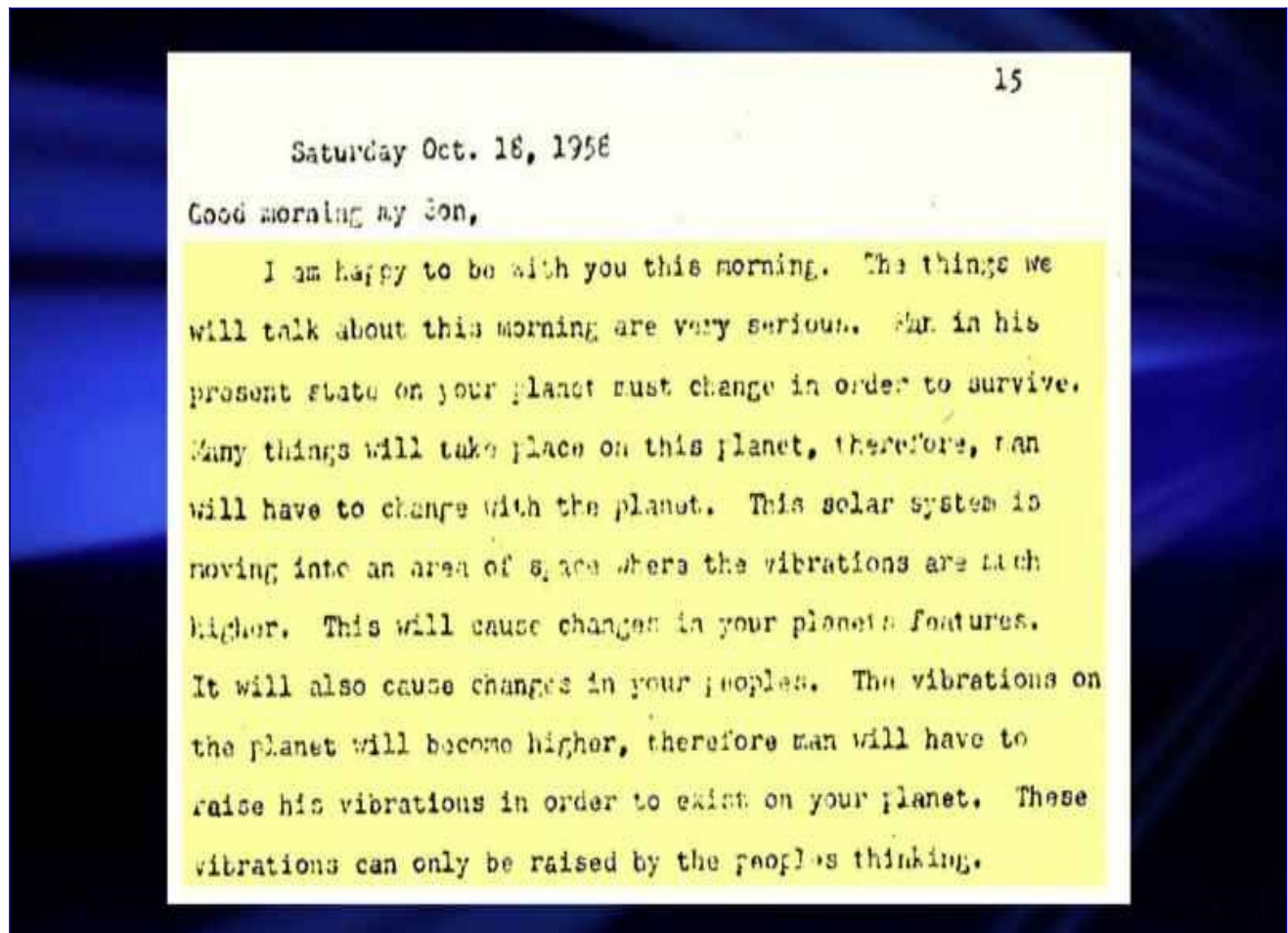

“I'm happy to be with you this morning. The things we will talk about this morning are very serious. Humans in their present state on your planet must change in order to survive. Many things will take place on this planet. Therefore, you will have to change with the planet.”

Now check this out.

“This solar system is moving into an area of space where the vibrations are much higher. This will cause changes in your planet's features. It will also cause changes in your peoples. The vibrations on the planet will become higher. Therefore, you will have to raise your vibrations in order to exist on your planet. These vibrations can only be raised by the peoples' thinking.”

Jay: Well, there you go.

David: I mean . . .

Jay: Wow!

David: That's the money shot right there.

Jay: That really is.

David: Now, **Corey**, do you think, based on this, that if the Sphere Alliance is putting up an outer barrier around the Solar System, and these ETs, these Draco, Orion-types can't get out, do you think that, based on this kind of information, that they're just not even going to be able to exist if they stay in here once this happens?

Corey: That's exactly what the Sphere Being Alliance communicated to me.

David: Oh, they did?

Corey: Yeah. And not only the Draco, but other non-terrestrials that are here intervening. They will not be compatible with the new vibration, or energy.

David: Let me just play devil's advocate for just a moment. Don't you think it's possible that, for people in the Cabal, that if they're looking at these benevolent ETs, or allegedly benevolent ETs, as actually

facilitating things like the fall of Atlantis, which we talked about last time, things like this, in which there actually is a mass death of negative beings, don't you think that the negative beings could see these benevolent beings as terrorists?

Corey: Oh, yeah. Yeah. They're going to see them as the enemy, of course.

David: Because they just want to be able to go on doing what they're doing forever and not be interrupted.

Corey: And according to their theologies and philosophies, they're doing what is 'good'. So they see these, what we call benevolent beings, they see them as evil.

David: Now, **Jay**, why do you think it's necessary for these negative entities to physically expire?

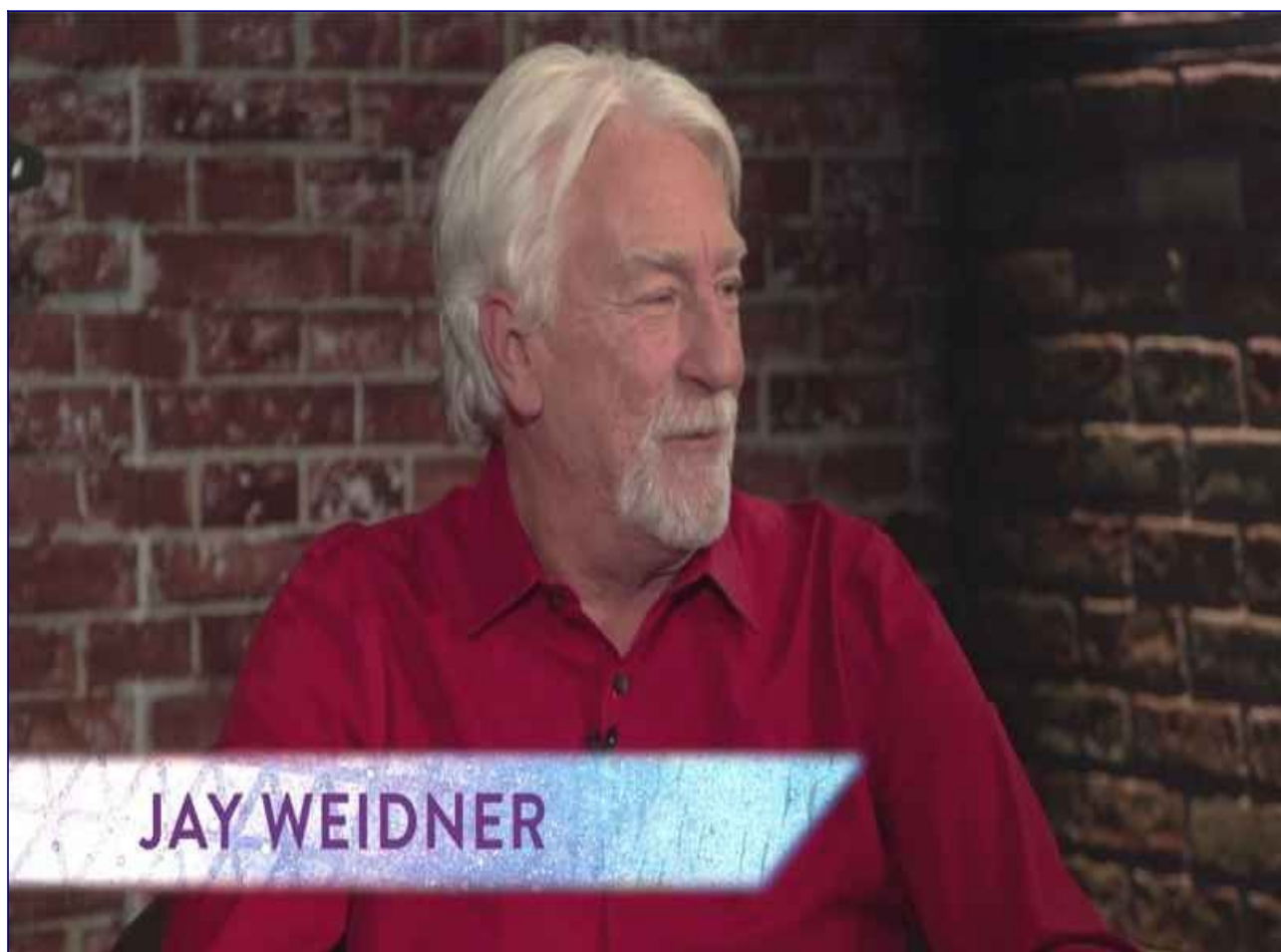

Jay: Well, because they're dictators of the whole Solar System, and this is a good thing.

Fulcanelli tells us in his chapter on the Cross of Hendaye that many beings will die when this event

comes, all right, but not all. And I think he was really talking about this cleansing, a cleansing of the whole area and getting rid of a lot of negative entities.

So I think that they are going to die, and I think that they're really worried – very worried. And I've heard this from other sources, not just **Corey**.

David: I mean, how bizarre is it that we got this guy – I think it's Nebraska or something like that, in the middle of Nebraska – [who] doesn't know anything about ancient prophecy? He's just an ordinary dude, gets brought up there, and they start giving this information through him.

Jay: Definitely my sources have told me that in the 1950s aliens began telepathically talking to very good humans, giving them information in order to facilitate the evolutionary shift of the human race to bring us into a larger manifold. That's what I've been told.

And the Sun is a central part of this thing. And the change that the Sun is going through is a central part of this thing.

David: Now, **Corey**, in The Law of One – we discussed this already – there was a statement about the idea that the illusion of space-time is granted for us to have the experience of seeing the results of our actions.

Do these . . . Is death part of the illusion of space-time?

Corey: Well, I guess it would be, since we're having our experience within that medium. But death is a part of also the learning experience.

David: So these beings aren't really dying per se. They're just being removed from one level of the planetary or interplanetary game.

Corey: They're being, I guess, recycled.

David: Right. And because space-time is ultimately an illusion, it does appear that these potential . . . that these periodic mass catastrophes, although there is the appearance of physical death within the illusion, that it's more like gardening, right?

Jay: Hm mm.

David: It's like plowing the field to harvest.

Jay: Yes.

David: What is the harvest? What happens, **Jay**?

Jay: Yeah.

David: It's the tilling of the soil, right?

Jay: That's right, yeah.

David: So what do the alchemists think about this idea of the metaphor of rebirth? They've used the 'new dawn' language in this.

Jay: Yep. They are not . . . They don't believe that death is the end. They believe that you want to extend human life to give each human enough time to figure things out. And they think we've been somehow messed with, so we have a short lifespan. And so we can never figure things out.

We die at like 70, 80, and that's it, right? And it's really not enough time to actually figure things out.

So alchemists try to do things to extend their life so they have more time here to figure it out. And the alchemists lore is that the average human can live to be 300 to 800 years old.

And just imagine if we lived to be 800 years old, how the world would be changed. There would be no wars, because nobody's going to fight war if you've got 780 years left to live, right?

David: Sure.

Jay: You're not going to have children until you're 200 years old. You're going to be very wise when you have children. Your children are going to be very wise.

You go to college until you're 150. You know what I mean? I mean, it's just a completely different world, and they've denied this to us.

The patriarchs in the Bible lived to be 900 years old, so . . .

David: Right.

Corey: Well, even the oldest and wisest among us right now are still spiritual children.

Jay: They are. And it's a very important part of our future to have us live longer lives. I think that's part of the vibratory change that's going to happen. And we're going to start living longer.

We already are actually living longer lives. When my grandparents were in their 60s, they looked like they were in their 90s, right? Nowadays, people in their 90s looked like people who used to be in their 60s.

Corey: And it's not because of all the pharmaceuticals we're pumping through them?

Jay: Ha, ha.

Corey: Ha, ha.

Jay: I hope not. Again, the pharmaceuticals could be a way to mitigate the shift that they don't want, right?

Corey: Yes.

Jay: Right? The fluoride in the water – when did it happen? The 1950s, right? And what does fluoride do? It calcifies your pineal gland.

Corey: Well, on that point, they do put things in the food and water that have metals and things that bring down our density, that keep our density lower.

Jay: That's right. We know that.

David: Well, the first Project Camelot whistleblower, alias, Mr. X, said that he was going through documents at a military defense contractor, and documents from the 1950s described that meeting with what you were calling the Blues and Eisenhower, in which the government denied them their request to bring us into a peaceful age as long as we had nuclear disarmament.

But then they said, “If you cover this up, you can get away with it up until 2012, and at that point we're coming back whether you like it or not. There's nothing you can do about it.”

So, **Corey**, since so many of these prophecies have revolved around the year 2012, the Mayan Calendar end date – there were crop circles that said it – does it appear, since you've got this date range of 2018 to 2023, that maybe we got an extension to have a little more time from what the original intention of the end date was?

Corey: You know, I don't know, but it's become very obvious from the panic and how quickly things are changing in the programs that the 2018 beginning date has obviously moved up.

Things are happening very quickly. So I think things are happening before these different Cabal groups had planned out. They were using these different techniques to view the probable future, getting information from non-terrestrials, and they were basing their plans on that – on that date.

David: Well, we're actually not done with The Brown Notebook. And if this hasn't already blown you away, there's more to come. So let's check that out.

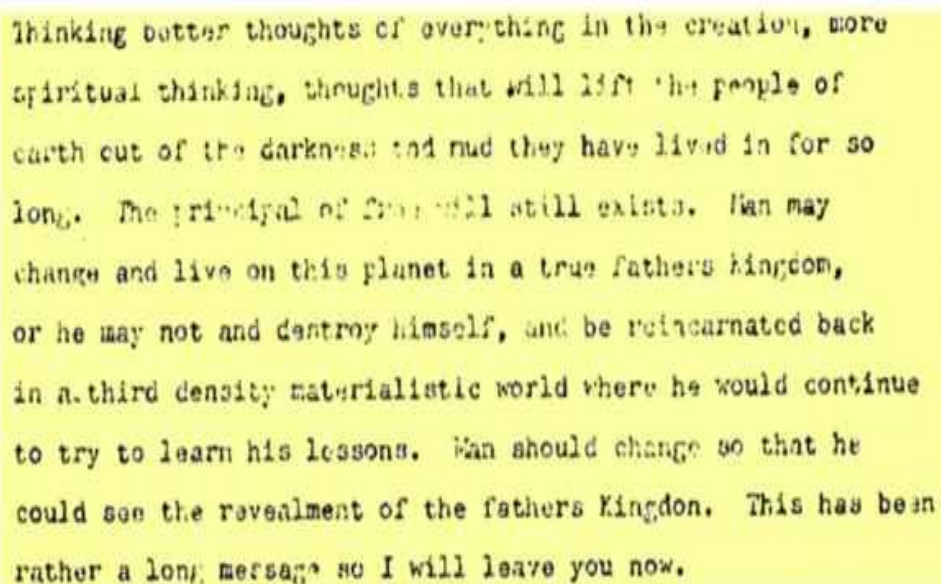

Thinking better thoughts of everything in the creation, more spiritual thinking, thoughts that will lift the people of earth out of the darkness and mud they have lived in for so long. The principal of God will still exist. Man may change and live on this planet in a true fathers kingdom, or he may not and destroy himself, and be reincarnated back in a third density materialistic world where he would continue to try to learn his lessons. Man should change so that he could see the revealment of the fathers Kingdom. This has been rather a long message so I will leave you now.

Odina my Son.

“Thinking better thoughts of everything in the creation, more spiritual thoughts, thoughts that will lift the people of Earth out of the darkness and mud they have lived in for so long. The principal of free will still exists. You may change and live on this planet in a true divine kingdom, or you may choose not to and destroy yourself and then be reincarnated back in another third-density, materialistic world, where you continue to try to learn your lessons. You should change so you can see the revealing of this divine kingdom. This has been a rather long message, so I will leave you now.”

David: So what they're saying there is the idea of planetary recycling, people being transported.

So, **Corey**, when we have these giant Spheres coming into the Solar System and then The Law of One source says that their job is the management and transfer of planetary populations, how do the Spheres . . . do you think . . . is it possible that those Spheres will be transporting people to other worlds once this transition is complete based on what we're seeing here?

Corey: It's absolutely possible because that's how they've transported me.

David: Ah, right. So why wouldn't they have the technology to portal out people by the hundreds of millions or billions?

Corey: Oh, yeah, easily.

David: The same way that they just did with you.

Corey: Yeah. And if they can use these Spheres to contain the entire Solar System, that's child's play to them.

Jay: And I've heard from high sources that they can just - “pfsht” - pick you right up and take you away. It just happens in a flash. And a lot of these missing people disappear this way, I think.

David: Absolutely.

Jay: Yeah.

David: Now, this is another quote from a later session. It's the same kind of thing – totally amazing.

after it is straightened out this time. This planet and solar system are moving into a new area of vibrations, in which conditions as they are now on this planet will not survive. That is why the peoples of this planet must learn the truth concerning the Father's creation. Love, peace and harmony is all that will exist in the Father's true creation. Many will not believe our story, but if they do not they are not punished by the Father. They are simply removed to another planet, in a just manner by the Father, where they will try to learn their lessons of love, peace and harmony all over again. Peoples of all planets must live in love, peace and harmony if they are to receive the full blessings of the Father. I will leave you now my son, we will talk again. I am your friend and companion in the service of the Father, Hutton.

Odina Vasu Boragas.

“This planet and solar system are moving into a new area of vibrations in which the conditions as they are now on this planet will not survive. That is why the people of this planet must learn the truth concerning the divine creation. Love, peace and harmony is all that will exist in the true creation. Many will not believe our story, but if they do not they are not punished . . . They are simply [David clears his throat] removed to another planet, in a just manner . . . where they will try to learn their lessons of love, peace and harmony all over again. . . .”

Jay: Interesting.

“People of all planets must live in love, peace and harmony if they are to receive the full blessings of the divine kingdom.”

Jay: Nice.

David: So once again, they're reiterating that everybody has to learn this, and if you don't get it, you continue your education on another planet somewhere else. And again, this seems totally to be what's happening with these Spheres.

We're actually seeing the technological or more measurable physical aspect of how they all kind of come in at the last minute right before this thing's going to happen.

Corey: Right.

David: Do you think . . . I mean, the Spheres have to be here to do something, don't you think, **Jay**?

Jay: I do.

David: They're not just there for show.

Jay: I do. This is very interesting, because, I mean, you know, that's . . . it's almost like the New Age Rapture. It makes you wonder if this is where the Rapture and all of that came from.

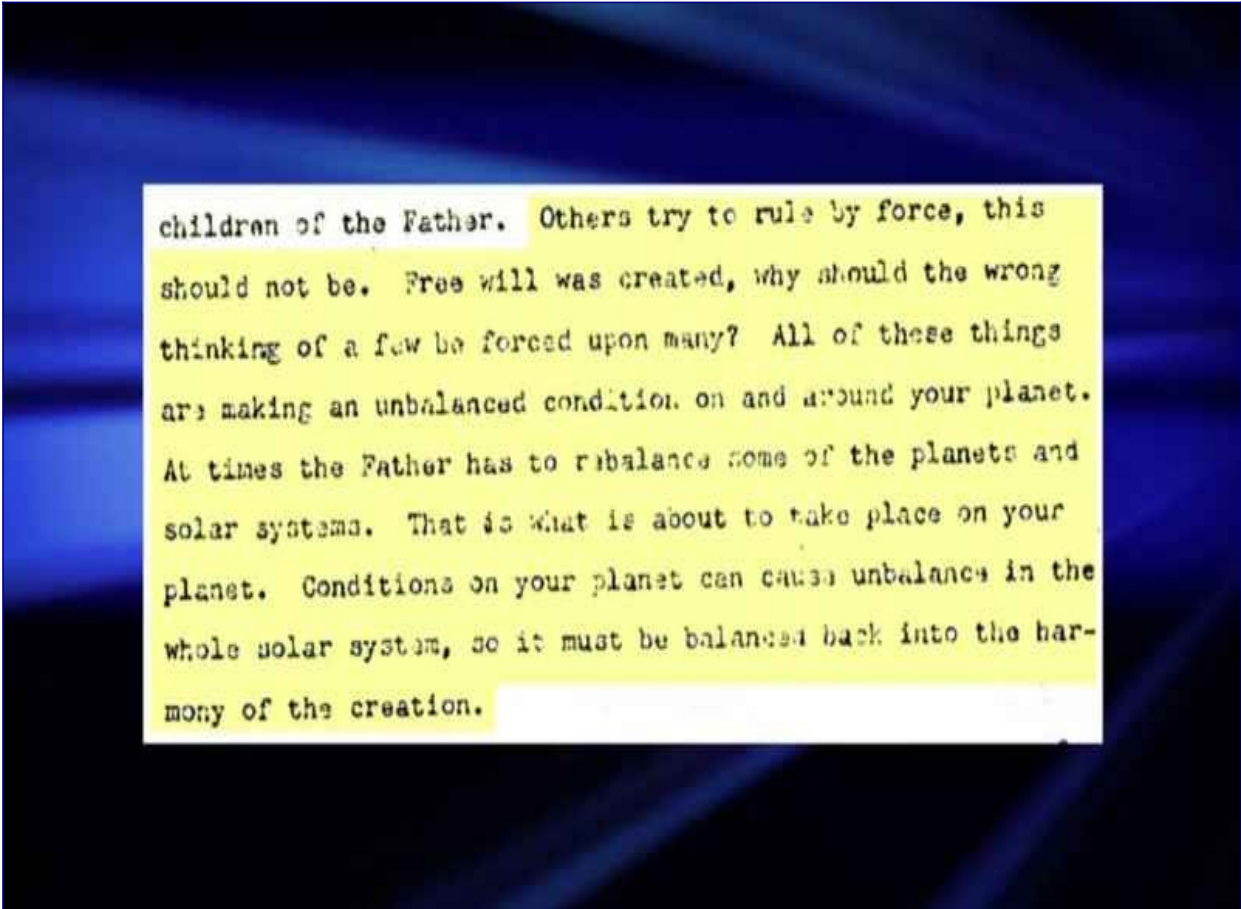

children of the Father. Others try to rule by force, this should not be. Free will was created, why should the wrong thinking of a few be forced upon many? All of these things are making an unbalanced condition on and around your planet. At times the Father has to rebalance some of the planets and solar systems. That is what is about to take place on your planet. Conditions on your planet can cause unbalance in the whole solar system, so it must be balanced back into the harmony of the creation.

David: Absolutely. Let's go on [and] have another one, because this is actually talking about the Cabal now and then why that change is necessary.

“Others try to rule by force. This should not be. Free will was created, but why should the wrong thinking of a few be forced upon many? All of these things are making an unbalanced condition on and around your planet. At times, the [father-mother-god] has to rebalance some of the planets and solar systems. That is what is about to take place on your planet. Conditions on your planet can cause unbalance in the whole Solar System, so it must be balanced back into the harmony of the creation.”

Jay: There you go.

David: So doesn't it sound like here, if they're saying . . . and they're using a patriarchal term, but as people are reading, “the Father has to rebalance the planets and solar systems.”

Doesn't that sound like the idea of these Spheres, like the Outer Barrier and all this kind of stuff?

Corey: Well, yes, because one of the things that was explained and shown to me was that these Spheres were spaced out throughout our Solar System and acting as a buffer, like a harmonic buffer, for these energies that were coming into our Solar System to give us more time to acclimate and adjust.

David: And it says here that the “rule by force” is creating an “unbalanced condition” and that they will, or whoever this Father is that they're talking about, has to rebalance what the Cabal has done.

So the defeat of the Cabal is obviously of key importance in this solar-system-wide rebalancing, which they're saying is some kind of flash of energy from the Sun.

I mean, to me this stuff pays off everything we've been talking about. It's just amazing.

Jay: It certainly is. Now it goes back to what I've heard was happening in the '50s. And again, everything happened in the '50s. Everything started there.

Corey: Oh, yeah.

David: **Tompkins'** data was that 1,500 different people were getting . . .

Jay: 1,442 people. The intelligence agencies had discovered 1,400 people who were in telepathic communication, just normal people, not physicists or anything. There were physicists, but others were guys like this guy from Nebraska and uncovering amazing amounts of knowledge, including **Tompkins** himself, who was receiving one of the 1,400, and he was receiving information about how to build space vehicles and things like that.

Corey: Now, is this “the 1,442 contactees”?

Jay: Yeah.

Corey: They call them “the 1,442”?

Jay: Yeah, “the 1,442”.

Corey: Huh.

David: **Tompkins**, in his book, describes that the people he's working with are throwing him these impossible questions and saying, design us a transport vehicle to get from cavern A to cavern B, and we need it by Saturday.

And he has no idea what he's going to do, and then he just channels it. And then they don't tell him what they're doing with it.

Jay: No. And he's unsure of where he's getting the information from. At the same time, he doesn't know how he could possibly build a ship that can house 300 people in a weekend. Ha, ha.

David: And then he concludes that they must be getting it telepathically from extraterrestrials.

Jay: Yes. Right – good extraterrestrials. And you think about if what **Corey** is saying is true, there's bad ETs here. You don't want to really face them. So how would you defeat them? You would do it this way. This is the most intelligent way to do it.

David: Balance the Solar System.

Jay: Yeah, balance the Solar System by taking good people, like this guy is, and feeding them information and getting him to release it. This stuff should have probably been released in the '50s.

On this day may the love and blessings of the Father
 shine thru the mist of ignorance on your planet of Sorrows,
 and reveal the light of the Father to many. I leave you now
 my son, I am your teacher and friend Hatton.

Odina Vasu, My
 blessings are with you.

Sunday Jan. 18, 1959

Good evening my son,

I am very happy to be with you this evening. I am Latue.
 I greet you in the love and light of the Infinite One, the
 Father within.

David: Yeah. So now this little quote, I'm not going to go into too much detail except just to say that it says, "I am your teacher and friend Hatton" at the end of the top one, and then "I am Latue" at the bottom one.

Hatton and Latue are the two beings that were talking to Carla that she was channeling before she starts to channel The Law of One. So these same beings found their way to Carla. Here's the beings – they're naming themselves – that are giving us these prophecies.

So they're still out there. Nebraska guy is not online anymore, but they jump over to Carla, and they start giving her the information. And that's what tuned her up to be able to receive The Law of One.

Jay: Right.

BAIRD WALLACE: GRAND SUMMARY

THE SPACE STORY AND THE INNER LIGHT

1st Edition June 1972
2nd Edition December 1972 Revised
3rd Edition June 1975 Revised

BAIRD WALLACE
BOX 158
GROSSE ILE, MICH. 48138

Baird Wallace: Grand Summary

THE SPACE STORY AND THE INNER LIGHT

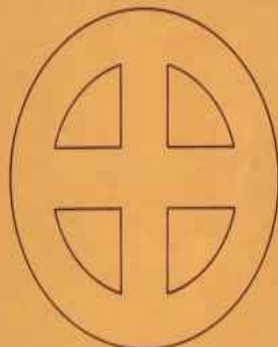

A SERIES OF ARTICLES
BY BAIRD WALLACE

David: So now what we have here is this book by Baird Wallace that summarizes all of what these different contactees were saying in the 1950s and '60s. He puts it all together in one unified message.

And I'm going to show you the publication date, June 1972. [i] scanned it right out of the book. You could probably still find this if you really look for it. It's called "The Space Story and The Inner Light", and I'm going to read you some quotes from this. We're not going to read it from the typewritten form here. You can pause it on your TV if you want to see that.

I'm just going to read it in a nice, favorable way like this.

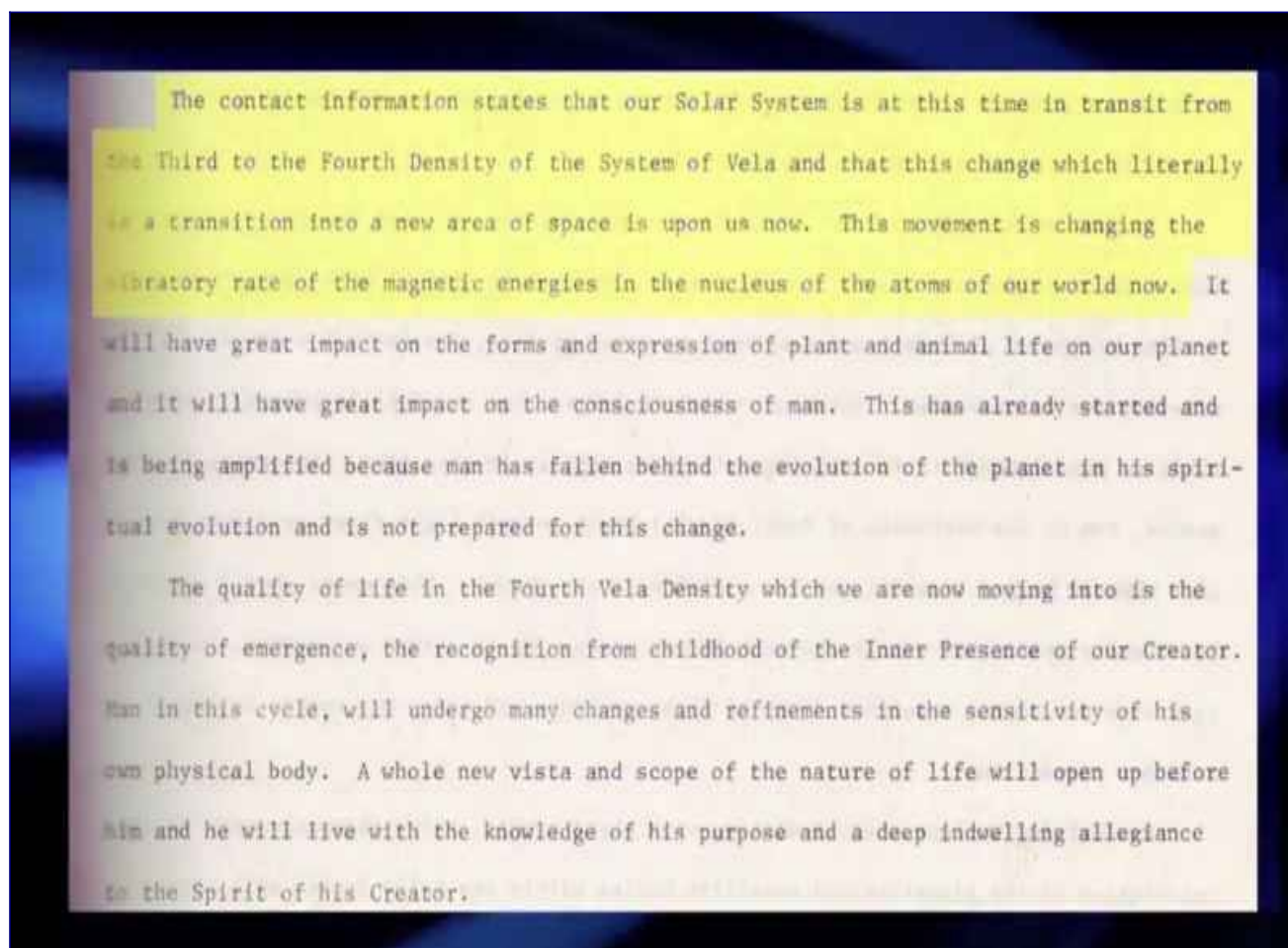

“The contact information states that our Solar System is at this time in transit. . .” - remember this is 1972 - “. . . from the Third to the Fourth Density . . .” **[David:** There it is. That's all the way back before The Law of One. They're already using the word 'density'.] “. . . of the System of Vela . . .” **[David:** That comes from George Van Tassel's information.] “. . . and that this change which literally is a transition into a new area of space is happening

now. This movement changes the vibratory rate of the magnetic energies in the nucleus of the atoms of our world now.”

David: So, **Jay**, this sounds a lot like alchemical.

Jay: It is. It is. Fulcanelli intimates several times in his book, “Mysteries of the Cathedrals”, that the entire human race is an alchemical experiment.

Corey says that 22 different races have come here to experiment on us. Other people have told me the same thing. And I think that, if I may, the experiment, I think, is, can we take a guttural creature, like in “2001”, and transform them into a very advanced spiritual being?

That, I think, is the main experiment. There's other experiments, like **Corey** says.

Corey: But you're right. It's genetic and spiritual. They say it's genetic and spiritual in context.

Jay: Genetic and spiritual. And as things like Gaia come out into the world, we're raising the vibe of everything and changing the game. And I think that Gaia is a big part of this whole change in consciousness.

David: Let's hear more of what he had to say about this meta analysis of all the different contact information.

“[This event] will have great impacts on the form and expression of plant and animal life on our planet and it will have great impact on the consciousness of [humanity]. This has already started and is being amplified because [Earth humans have] fallen behind the evolution of [their] planet in [their] spiritual evolution and [are] not prepared for this change.”

David: Now, **Corey**, this is from 1972. Did you hear anything that sounded like that?

Corey: Well, what I said earlier, the Spheres are here to buffer the energy so we can acclimate at a slower rate because the Earth is changing faster than we are. And that's why . . . If they didn't do that, there were going to be more catastrophes . . . Earth changes happening and catastrophes because of it, and there would be fear and all that kind of stuff that would make it harder for us to raise our vibration.

David: So they really have needed this sort of intercession of the Sphere technology because we're not ready, just like it said here in '72.

Corey: Right.

David: Pretty amazing, huh?

Jay: Pretty amazing.

David: 40 years before 2012.

Corey: And them talking about the Solar System moving . . . because I hear people talking about the Solar System as being hit by all these energies . . .

David: Or the photon belt.

Corey: Right. It's shocking to hear that they're saying the same thing the Secret Space Program was saying, is that our Solar System is moving into a part of the galaxy that has like a nebula of clouds, high-energy particle clouds, that are causing changes to our Sun and our Solar System.

David: And you said they were sending guys into those clouds in spaceships to see what happened to them, right?

Corey: Right. Well, they were sending them out there to investigate. And people . . . weird things were happening to them. They were having breakdowns, psychological breakdowns.

David: Well, could you go through that? Like, different . . . Not everybody responds to the cloud the same way, right?

Corey: Exactly. And they were artificially recreating this energy in closed environments and having unsuspecting people go in thinking that they're doing unrelated work and seeing what it did to them. And they were doing it to our own people.

David: What are some of the things that happened?

Corey: Well, people that went in that were like sociopaths, they went nuts. They lost it.

Jay: That's actually what I've heard is about to happen.

Corey: Yeah. And the people that were positively oriented started getting all blissful and just happy and whistling, that kind of thing. And people that had, you know, people that had psychological issues, those became enhanced.

David: Wow! So this is really lining up very beautifully with what he's saying.

Jay: So the good get better and the bad get worse.

David: Ha, ha.

Corey: And the crazy get crazier.

David: All right, so now we're going to go on with this quote from this amazingly vetted-out material and just see how much more it lines up with everything we've been discussing.

“The quality of life in the Fourth Vela Density, which we are now moving into, is the quality of emergence, the recognition from childhood of the Inner Presence of our Creator. [Earth humans] in this cycle, will undergo many changes and refinements in the sensitivity of [their] own [bodies].”

Now, **Jay**, you said before that there was a really interesting Masonic ritual where they keep you in the dark for a long time . . .

Jay: Right.

David: . . . and then bring you out. Could you just kind of go over that again here?

Jay: Well, again, this goes back to the pineal gland. It's kind of like tricking the pineal gland, you might say. This is a poor man's way of getting the Elixir of Life.

So we know that serotonin is emitted from the pineal gland when light strikes it in the morning. And we know that melatonin comes out of the pineal gland when you're in the dark.

We know that melatonin reverses the aging process, okay? And so what they would do, in my opinion, was they would put you in a dark room for three days, complete darkness, and then your brothers, the Freemasonic brothers, would come, and they would put you into a dark coffin, light-free coffin, and then they would take you to either the top of a mountain or the top of a building, somewhere where you could see the rising Sun. And you're blindfolded.

And if anybody knows the Masonic rituals, this is starting to make a lot of sense.

David: Oh, yeah.

Jay: And so then you're taken out of the coffin, and your brothers face you towards the Sun. They take off your blindfold, and the Sun hits your eyes. And for three minutes, you have to stare into the Sun.

Then you put your blind . . . By the way, it's like a psychedelic experience when this happens.

David: Well, your brain has generated tons of melatonin.

Jay: Absolutely. We know that **DMT** is very close anatomically to serotonin, okay? And so what you're doing is you're getting almost like an endogenous **DMT** rush. It's your own **DMT**, though. It's homeopathic.

David: So it's like the melatonin is methylated. It gets suddenly transformed.

Jay: Into a super-serotonin.

David: Right.

Jay: And then they put you back in the casket, and they take you back into the dark room. You have to stay for 40 days.

David: Total darkness.

Jay: Total darkness. No light. And then what happens is that the super-serotonin turns into super-melatonin, all right?

So first it was melatonin. Then the light activates. It turns into a higher vibratory super-serotonin. And then once you get in the dark, that's transferred to super high vibratory super-melatonin, which begins to almost immediately reverse the aging process.

And supposedly you will lose 15, 20 years in this 40 days that you're in there.

And it's not a pleasant experience, from what I've heard.

David: Do they hit you with light again at the end of the 40 days?

Jay: No, they let you out.

David: Oh.

Jay: That's supposed to be . . . They let you out at night because it's very, very difficult to get back into the light after you've been in this experience. Your eyes are very sensitive. So usually, they let you out at night, and you usually become a night person for a little while.

David: **Corey**, have you heard of maybe some more advanced, perhaps chemical or energetic, means where some process, like what he's describing, might be able to advance people's psychic ability?

Corey: Well, yes. They chemically enhanced intuitive empaths with shots. Intuitive empaths that I run into are extremely advanced, but if they were to go for like six weeks or eight weeks without these shots, their abilities begin to diminish.

Jay: Right.

David: All right, well let's go on with this because we got a little more of this to get through.

“The whole new vista and scope of the nature of life will open up before them, and they will live with the knowledge of their purpose and a deep, in-dwelling allegiance to the Spirit of the Creator.”

David: That sounds great. Now, we're going to talk about this quote here, about what happens. And, again, we're not going to read it off the paper. We're going to do these nice slides.

“Summarizing various sources dealing with these events . . . “ [the solar flash] “. . . major rearrangements in the orientation of the planets and the satellites within the Solar System will occur.”

David: Now, before we go on any further here, **Corey**, have you heard about planetary orbits changing, like maybe the Earth's orbit extending in the number of days it takes, things like that, once this happens?

Corey: Yeah. And also about the orbits of the planets, that unlike some other solar systems, the planets are all askew. They're not in harmony at all. That's . . . Yeah, that's very interesting.

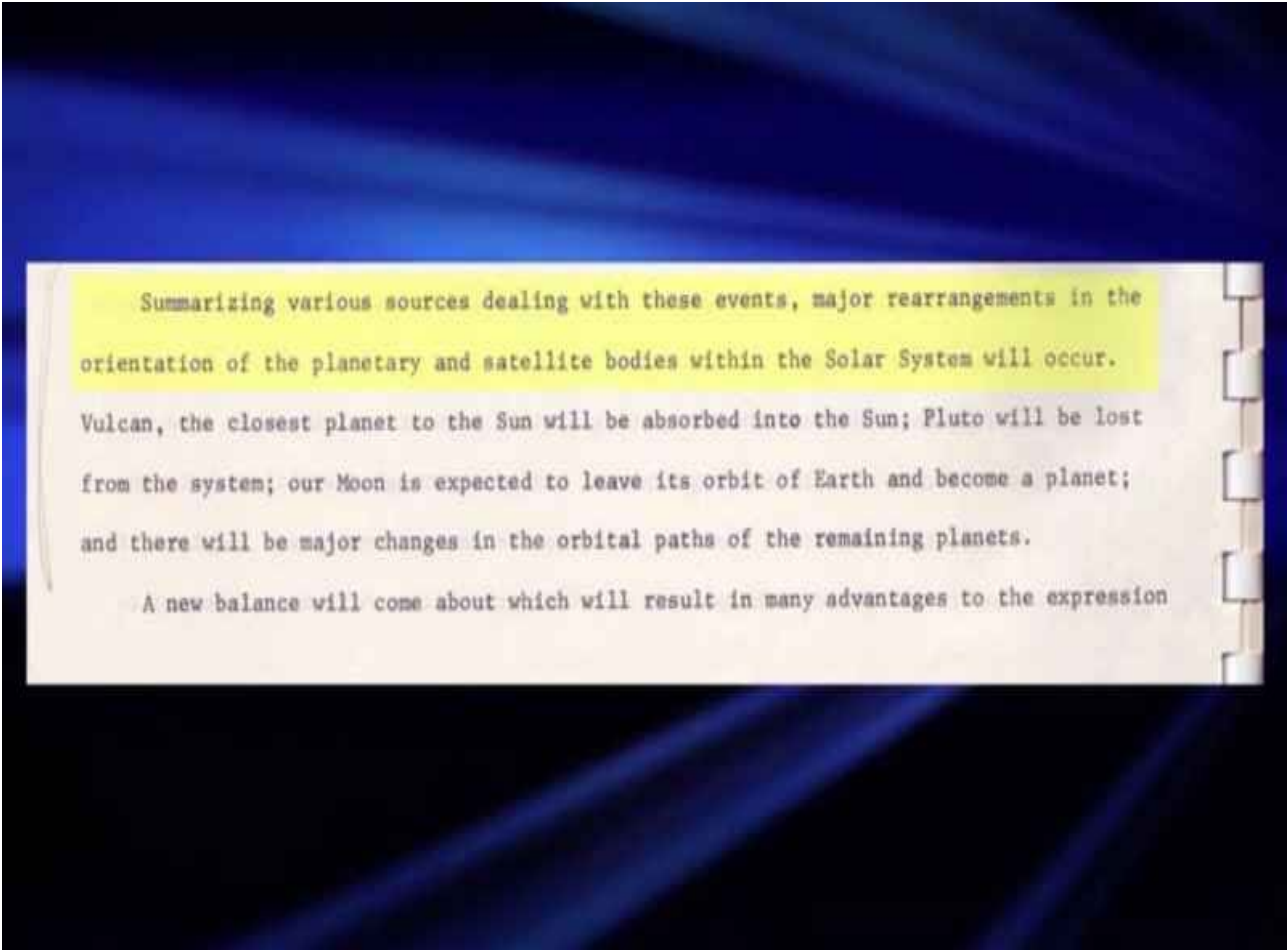
A document page with a blue background and a yellow highlight. The text is in a typewriter font. The highlighted text reads: "Summarizing various sources dealing with these events, major rearrangements in the orientation of the planetary and satellite bodies within the Solar System will occur." The rest of the text on the page reads: "Vulcan, the closest planet to the Sun will be absorbed into the Sun; Pluto will be lost from the system; our Moon is expected to leave its orbit of Earth and become a planet; and there will be major changes in the orbital paths of the remaining planets." and "A new balance will come about which will result in many advantages to the expression".

Summarizing various sources dealing with these events, major rearrangements in the orientation of the planetary and satellite bodies within the Solar System will occur.

Vulcan, the closest planet to the Sun will be absorbed into the Sun; Pluto will be lost from the system; our Moon is expected to leave its orbit of Earth and become a planet; and there will be major changes in the orbital paths of the remaining planets.

A new balance will come about which will result in many advantages to the expression

David: Isn't this crazy? 1972.

Corey: Yeah.

“Vulcan, the closest planet to the Sun, will be absorbed into the Sun; . . . “

David: And in The Law of One, they say it's a first-density planet, so it's not visible to us. It's like an energy ball.

Jay: Right.

David: It's not actually visible, but it gets reabsorbed.

“. . . Pluto will be [kicked out of our Solar System]; . . .”

David: It kind of already has been by NASA. Ha, ha.

Jay: It already has. Ha, ha.

“ . . . our Moon is expected to leave [the] orbit of [the] Earth and become [its own] planet; . . . ”

David: That's interesting. I don't know if I'd agree with that, but it probably will get kicked out, at least jettisoned from the Earth's orbit.

Jay: It is slowly moving away from the Earth.

“ . . . and there will be major changes in the orbital paths of the remaining planets.”

David: So I mean, there again is exactly what we're anticipating based on insider data. Now, let's go on and read the rest of this.

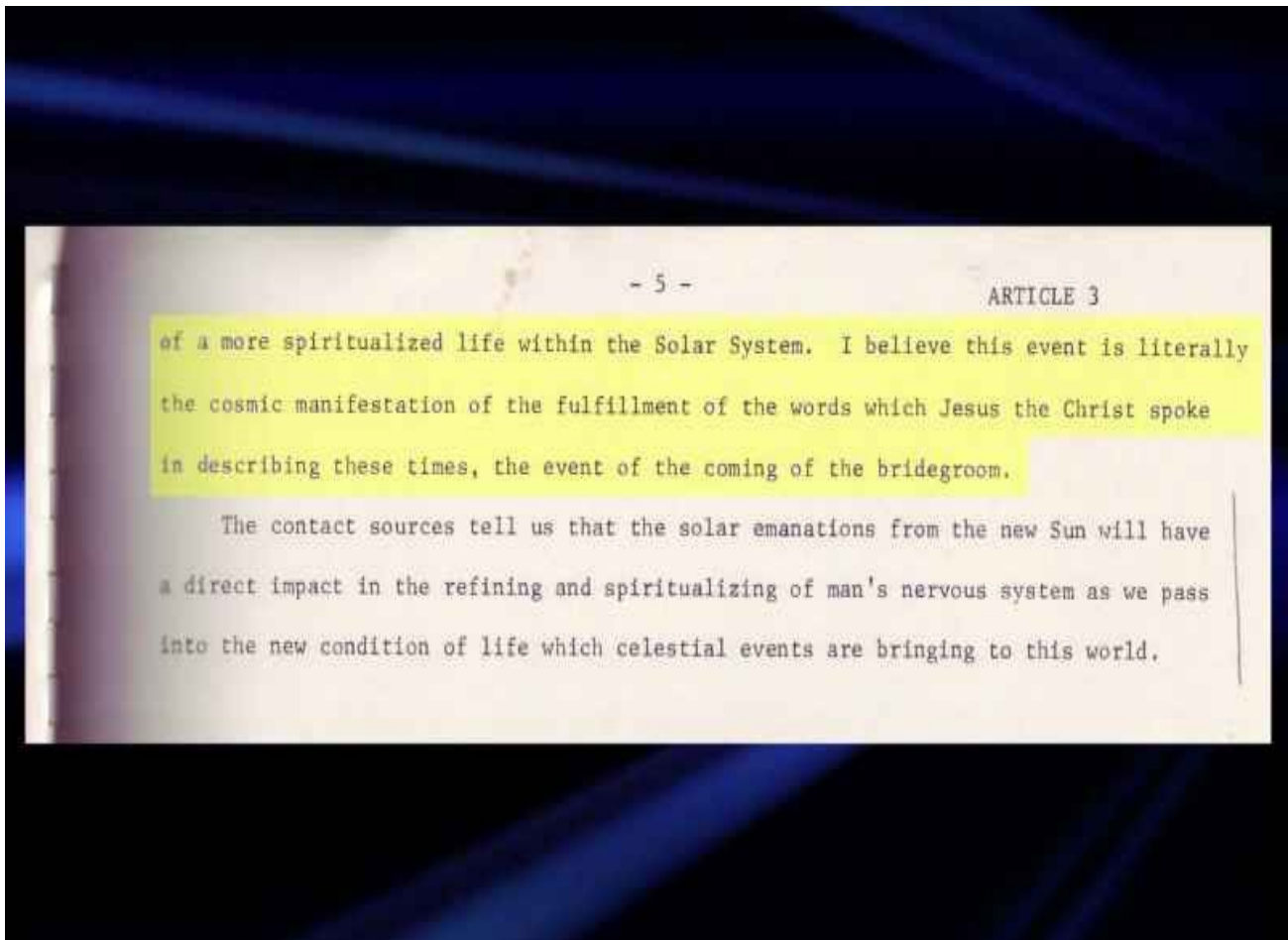

“A new balance will come about, which will result in many advantages to the expression of a more spiritualized life within the Solar System.”

David: That is Ascension, obviously.

“I believe . . . “ [This is the author speaking.] “. . . that this event is literally the cosmic manifestation of the fulfillment of the words which Jesus the Christ spoke in describing these times, the event of the coming of the bridegroom.”

David: And that is in the same book of Matthew right after they talk about the harvest metaphor. The bridegroom is just another symbol – the wedding, the alchemical wedding - . . .

Jay: It's the alchemical wedding.

David: . . . the wedding of flesh to spirit.

Jay: That's right.

David: Like the eclipse.

Jay: That's exactly right. That's what they're saying there. They're talking alchemy there.

David: And **Jay**, Kubrick is using eclipses and stuff all the time in “2001”, isn't he?

Jay: All through “2001” there's at least five eclipses in the movie.

David: So do you think Kubrick was aware of this biblical analogy to the wedding of flesh and spirit?

Jay: Oh, I do. Absolutely, I do. I believe that he was . . . I don't know if he was a practicing alchemist, but he definitely understood alchemy . . . and the Cabal.

David: Now, why do you think Kubrick at the last minute dissed the guy that wrote the score and then picks “Thus Spake Zarathustra”?

Jay: What do you think? Ha, ha, ha.

David: Well, I already know the answer. I'm just kind of throwing him a bone here.

Jay: I know the answer, too, because Zarathustra was the Persian alchemist. And from the very beginning, he's saying, “This is alchemy. Thus spoke the alchemist.”

And the opening trumpet from “Thus Spake Zarathustra” is over the eclipse at the beginning of “2001”. So there you go.

David: Zarathurstra is Zoroaster, . . .

Jay: That's right.

David: . . . who is the author of the prophecy of Frashokereti, . . .

Jay: That's right.

David: . . . where the Sun gives off this flash and transforms humanity.

Jay: Yep.

David: All right. So we're just going to finish this out really quickly, because we're almost done there. I just want you guys to hear this last little bit.

“The contact sources tell us that the solar emanations from the new Sun will have a direct impact in the refining and spiritualizing of [our] nervous systems as we pass into the new condition of life which celestial events are bringing to this world.”

Jay: Okay. So the “refining and spiritualizing of the nervous system” . . . The nervous system carries electrical currents through your body.

David: Yeah.

Jay: The Sun is essentially an electric Sun, as **Corey** has pointed out.

Corey: It is.

Jay: And so when the new Sun comes, it again goes through your eyes, hits your endocrine system, changes the nervous system, makes us more electric, advanced. So we can live longer.

David: Right.

Jay: We're light bodies.

David: And the eclipse is like a metaphorical example of a conjunction that's much greater, an alignment that leads to this solar emanation.

Jay: That's right. That is exactly right.

David: All right. Well, **Corey**, I mean, what do you think about all this from 1972?

Corey: It's unbelievable. I mean, I was two years old. Ha, ha. And this information, I didn't hear until fairly recently from, of course, a much different nonterrestrial source.

David: Do you think there's any possibility that somebody could have faked all this – the guy in Nebraska in 1958 – Baird Spalding [**David** means Baird Wallace.], 1972, reading all these different vetted-out channelers and how well it lines up with what you know?

Is there any way this could have been faked or somebody could have made this as a big hoax?

Corey: This is way before the time of the Internet, and your average library, I don't know if they would have all this information. And if it did, you would have to hunt and peck for years. That just doesn't seem practical.

David: Well, knowledge was kept secret, too, right, **Jay**?

Jay: Yeah, of course it was kept secret. This is clearly absolute proof, as proof as you can get, that what they're saying about this extraterrestrial telepathic contact was really truly going on.

David: Absolutely.

Jay: Yeah. I mean, I was around back then. I wasn't very old, but we were not very sophisticated in 1972. This is pretty sophisticated stuff.

David: Yeah, it's stunning. And this is stuff that was classified in secret societies, and yet, these guys in Nebraska are pulling it in.

Jay: And probably driving the Cabal crazy.

David: Oh, yeah.

Jay: Yeah.

David: Oh, yeah. They're trying to stop this.

Jay: Yeah.

David: Well, that's all the time we have for this episode. I hope you're as amazed as I am.

I wanted to present this information to you properly. I've been holding onto this stuff for a long time. I used to always close my conferences with this.

This to me is some of the crown jewels of my whole collection. And now with the three of us together, it's really the right way to present it to you. I hope you've enjoyed it.

This is "[Cosmic Disclosure](#):". I'm your host, **David Wilcock**, with our special guest, **Jay Weidner**, and I thank you for watching.

[Cosmic Disclosure: Deeper Disclosures from William Tompkins](#)

Season 7, Episode 7

David Wilcock: All right, welcome to "[Cosmic Disclosure](#)". I'm your host, **David Wilcock**, and I'm here with the insider's insider, **Corey Goode**, who has brought us a truly incredible repository of cosmic information that has now been verified by the insider **William Tompkins**, who at 94 years old, is a World War II veteran who has provided stunning corroboration of what **Corey** has had to tell us.

So, **Corey**, welcome to the show.

Corey Goode: Thank you.

David: So what we're going to do now is we're going to begin with a little excerpt of some of the things that **Tompkins** has been sharing with us about the amount of unlearning that is going to be necessary as we move into Full Disclosure. Let's take a look.

* * * * *

SELECTED BY EXTRATERRESTRIALS

William Tompkins: People all over this planet, for at least 6,000 years, have been influenced by extraterrestrials: the Dracos and the Reptilians.

They have taken the information that is in, essentially, every school on the planet and they've modified

the information. All history documentation in this country and in every country on the planet have been given lies about astronomy, lies about mathematics, lies about technical capabilities, lies about the universe, you name it. Okay?



Everything have been lies. Every PhD on this planet, whether they're scientific, whether they're medical, makes no difference. Every book that they read the six years they were in the university are lies. They are not telling the truth. They were not taught the truth.

At that time [when World War II began], we had 34 admirals in the Navy. All of them had been through Annapolis. They learned how to learn everything about the Navy, everything about history, everything about mathematics, everything about astronomy, you name it. They learned all lies.

So who did the Secretary of the Navy Forrestal select for this job?

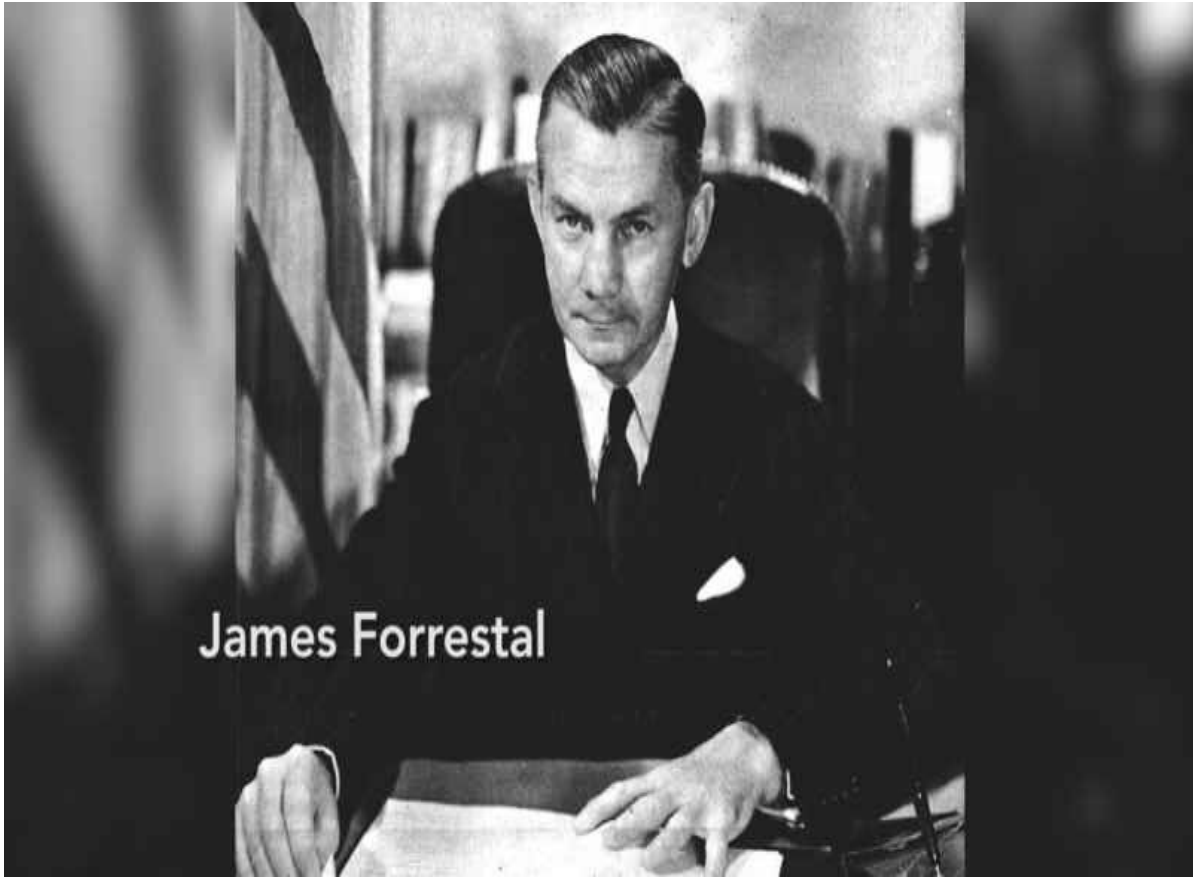

James Forrestal

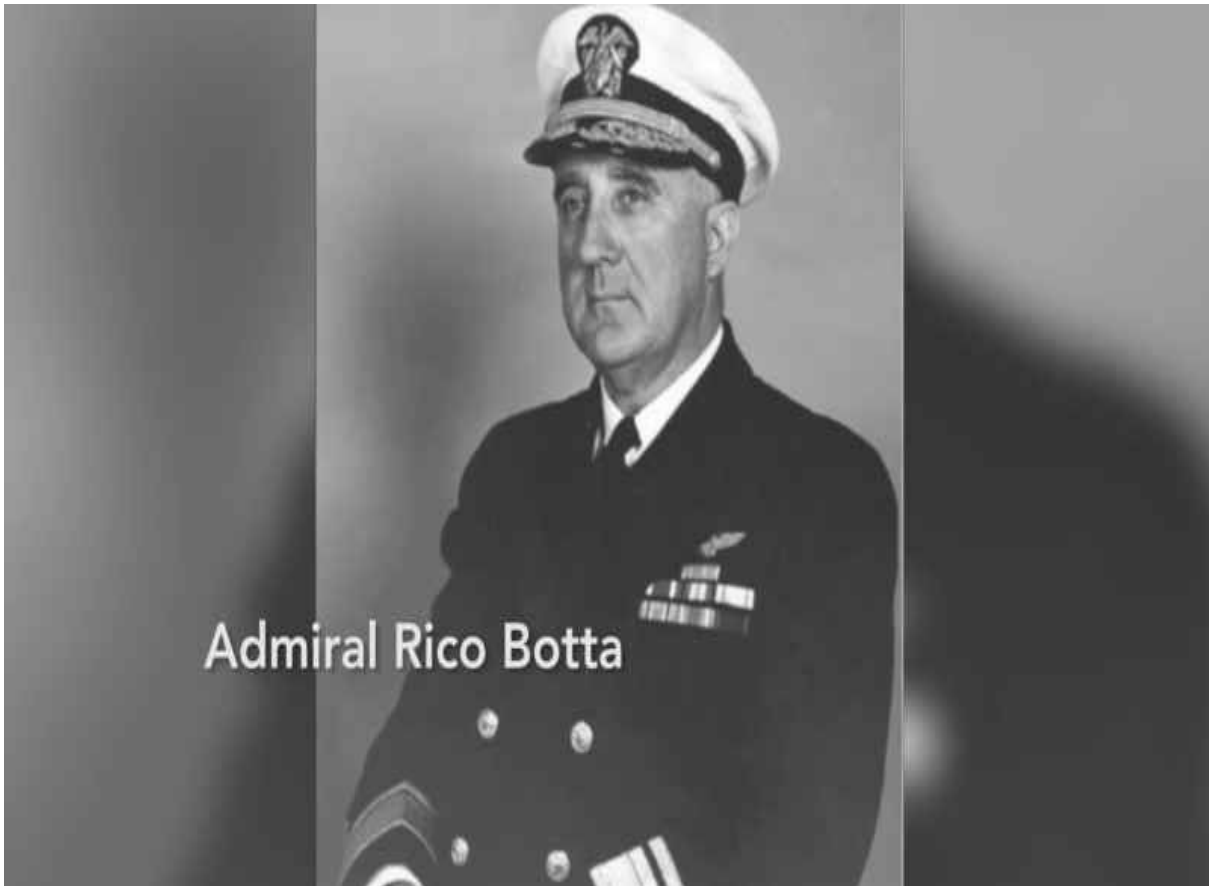

Admiral Rico Botta

Turns out Admiral Rico Botta was not an American. He was born in Australia. The Secretary of the Navy selected an Australian man who had not been infected with the lies that the Reptilians had taught us. He was freer of that.

So the Secretary of the Navy was aware of this because he had been contacted by Nordic extraterrestrials, people here trying to help United States. Okay? Very important point.

So when I was selected, I hadn't been to the universities. I hadn't gotten the bad information. I hadn't been given the wrong information. And this is the reason I was selected, because I was knowledgeable of the Navy, I was knowledgeable of what the threats were, but I hadn't gone to the university and picked up all the lies. Very important.

* * * * *

David: **Corey**, how do you feel about that? That's a pretty bold, cowboy statement that **Tompkins** just made here.

Corey: It was common knowledge in the programs. They would talk quite often about how the physics models that we're using down here on the planet are incorrect. And they have not been corrected on purpose.

They use different hyperdimensional mathematics models than what are used down here. You know, the physics models, . . . You know, we're still on this quantum and, you know, classical physics model.

David: Sure.

Corey: While they are deeply into this electro-plasmic universe model of physics, which is the true model.

And another thing he mentioned was that they wanted people that had not been, I guess, corrupted by this incorrect education. That is VERY COMMON in the programs.

That's why they were taking children in, because we were not front-loaded yet on different religious ideas, social programming. A lot of that hadn't occurred yet. So they had basically a blank slate to work with.

David: It is interesting isn't it, the government studies that have shown that if they did disclosure, the two groups that would be the most hard hit by it would be religious people and scientists.

Corey: Yep, the academics.

David: So do you think that this science itself becomes a religion?

Corey: Absolutely. We spend life using every experience or information that we've heard from people we respect, we use that as little pieces of sand to grind into a lens that we use to hold up to all information coming in to interpret it.

Those are all belief systems. They're all religions, even science.

David: Yeah. He also mentioned astronomy. And where do you think astronomy has fallen short?

Corey: I think that keeping astronomers ignorant of the electro-plasmic universe model sums it up.

David: Right.

Corey: They are making calculations on what they're observing and using incorrect math to make the calculations.

David: If we're acknowledging that Reptilians exist, how would that happen?

Corey: Well, you often hear that the “victors write the history”. Beings that are in control dictate what the minions get to hear.

David: Right.

Corey: And it's all done for control purposes. If you keep people ignorant, it's a throwback to people not being allowed to read back in . . . thousands of years ago, or currently in some places now even.

You're keeping people ignorant so they don't begin to think, or they don't have the ability to do further research on their own. They have to go by what they are told.

David: So when you say “the minions”, you're saying that we have various pressure points in our informational system, our educational system, that can be manipulated. Humans are being manipulated,

maybe wittingly, maybe unwittingly, by an extraterrestrial agenda in terms of what information makes it into the universities.

Corey: Yes. They've been able to get us to program ourselves through social norms – what's socially acceptable. That's programming. That's a control system.

And the same goes for educational systems.

David: So how does this play out in terms of other civilizations that go through the same thing? What would we expect to see as this knowledge embargo breaks down?



Corey: If you remember Mica, he's an ambassador from a nearby planet, that they've already gone through all of this change that we're starting to go through.

And what he stated is that after we get the truth, or a full data dump of a Full Disclosure, we're going to

go through – after we go through the five stages of grief, you know, denial and all that – we're going to go through a consciousness renaissance.

All these brilliant people that are scribbling down these math equations that they think are so brilliant, and they are given this hyperdimensional model? They've still got brilliant brains.

And they're going to take this correct science and mathematics and they're going to run with it.

David: How does our relationship to the universe change once the science is authentically given, instead of this reduced model?

What do we look like now as conscious, sentient beings in this universe?

Corey: If you take away a lot of the mystery of the universe, you're empowering people both intellectually and spiritually. They've got a lot more room to grow.

David: What do you think it does to consciousness once this science suppression is removed? How do we see consciousness differently?

Corey: Consciousness, I believe, is going to evolve to the point to where we are able to – when we have these correct models, we have Full Disclosure, we have a better understanding of the nature of the universe – we're going to be able to not only understand our place in the universe, but our place on the planet and in our various societies.

David: Do you think that it will be more commonly accepted that consciousness is a field and not just something localized in the brain?

Corey: That's one of the sciences that has been suppressed. So, yes, that will be revealed.

David: What personal experience did you have with that science being suppressed in your programs?

Corey: Well, it was just common knowledge that the powers of the human consciousness were being suppressed on the Earth, because our co-creative consciousness interacts with matter, because we can interact with matter.

The same people that are controlling what we learn scientifically, they're able to control us by causing

us to . . . It's like the root of their magic.

They will create a catalyst and cause us to manifest something into occurring.

David: What do you think happens when we get to this idea that there is only one consciousness in the universe? How does that affect us once that becomes public?

Corey: Well, we figure out that we are all One. We're not as different and separated as we think we are.

David: Cool. All right. So in our next segment, we're going to go more into detail about the packages that **Tompkins** referred to only briefly in other episodes.

I really didn't understand all the semantic depth of the word "package" until I got this knowledge. And I think you're going to be really fascinated too. Let's take a look.

* * * * *

GERMANS AND ETs

William Tompkins: They found out about extraterrestrials advising the SS in Germany and Hitler on how to build massive spacecraft carriers, how to build massive space cruisers to operate with the Reptilian Draco space navy.



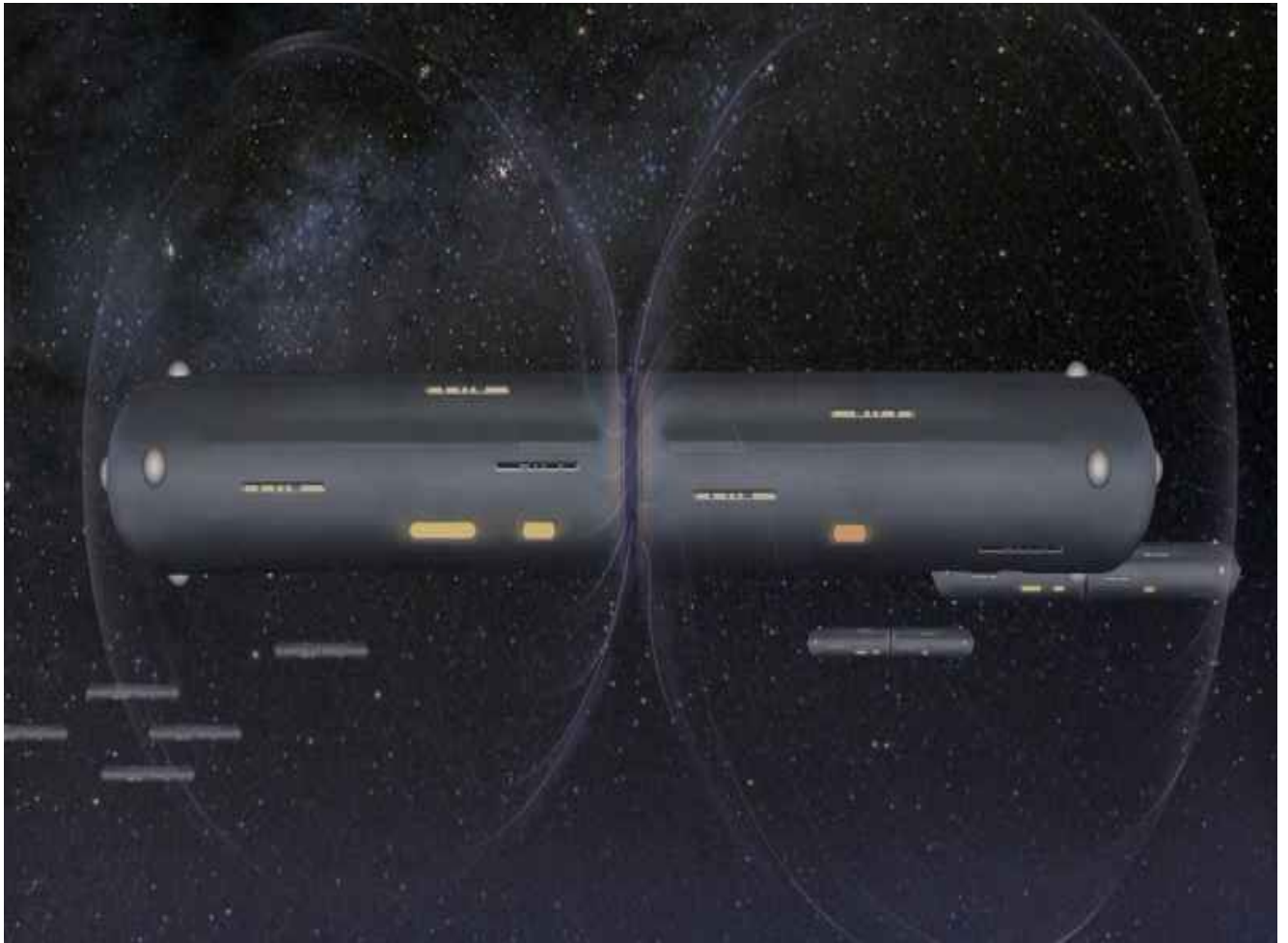

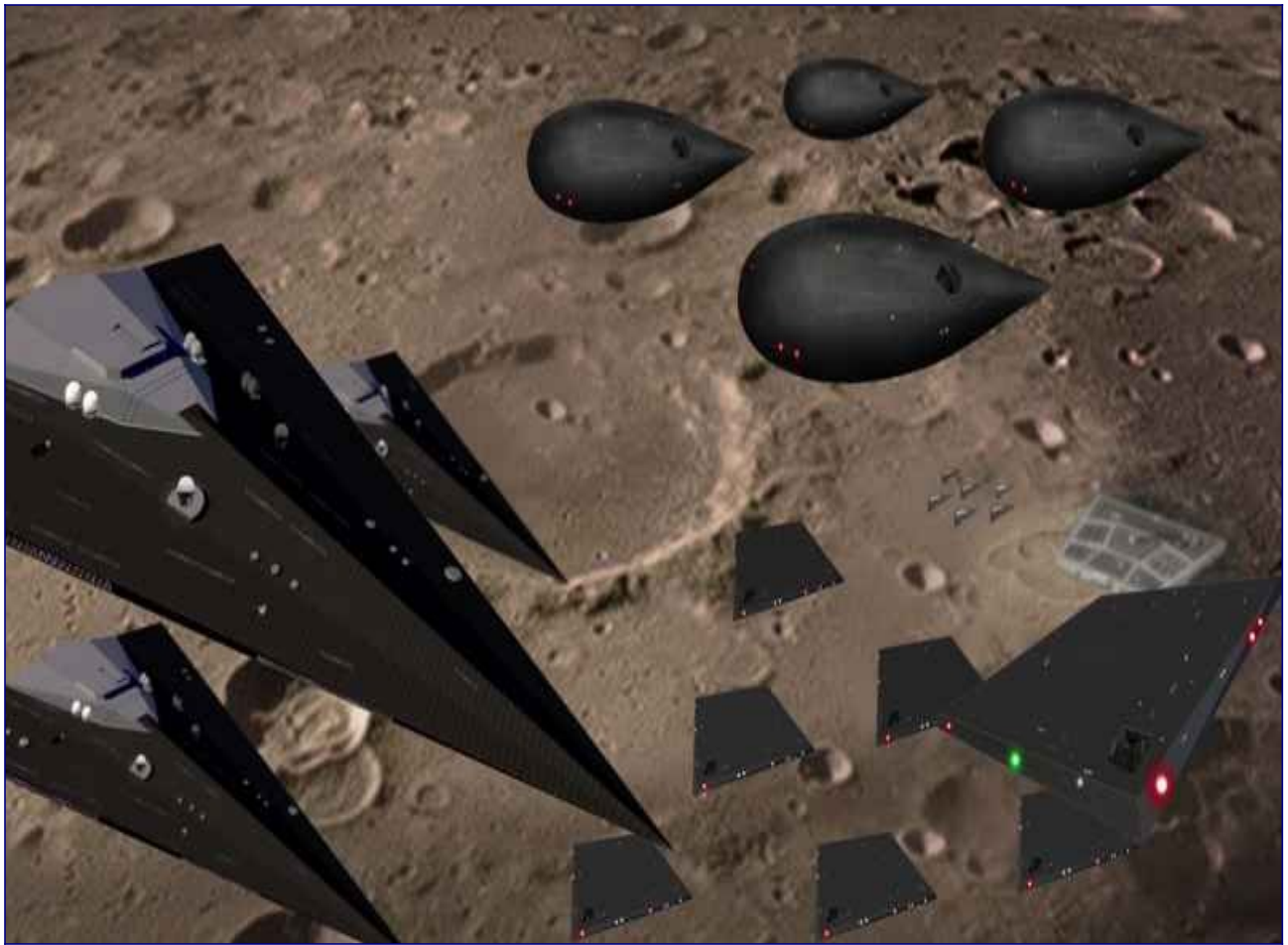

Now, what this turned out to be, after I got heavily into this, was this is the first time anybody in the United States knew that extraterrestrials were actually here on the planet and actually were working with Germany, had agreed, legal agreements, with Hitler.

We then had these Navy spies, which we had operating there 24 hours a day from 1942 to the end of the war.

I worked in that office. The Admiral's aide would wake me up after 12 o'clock at night. He would tap me on the shoulder in the barracks.

All he would say is, "He's here." I would get up, dress real fast. The aide would take me over to the tall building, the command center. We'd go upstairs to a small office at the top of that building, not the regular big Operation Command rooms, small office.



The Admiral would be sitting at the head of the table. The operative would be on the backside. I'm sitting next to the Admiral and one of the three captains is sitting next to me. The typist is sitting on the other side at the end of the table.

But actually what the operatives brought were perspective sketches of different research that's going on inside of laboratories.

They took photographs of the Germans next to the UFOs. Some of them were only 40 feet in diameter. Some were 250 foot in diameter.

So to try to put a perspective on this, these documents then, we put together what was called packages.

These types of packages, which are contracts to all of the Army, all of the Navy aerospace organizations' laboratories, and all of the aircraft companies, biomedical research companies, all over the United States.

Everybody got at least one package. Many people got as many as 10 or 12 packages to study. That was going on the whole length of the war.

It's a contract that they are required to implement the study. They're not being asked, "Are you interested?" No. So it's a different contract, okay? It's a requirement.

And, of course, it's way above "Top Secret", but we don't have the documents stamped that way.

So the package then contains all this different information about, say, communications. All of it totally unreal to any possible engineering group.

So, like say, your President of Engineering at Northrop. The package that you guys got was in German. Okay? Some of it was in hieroglyphics. Nothing that you had in a package would be understandable.

You don't know the mathematics. You don't know the writing. You don't understand the photographs. You don't understand the rough sketches that the Navy operative makes.

So you're handed a box full of very poor information. You are required to take that and run with it, but you have no background. You don't have any book on any subject that you can flip through the pages to try to figure out what this even is.

You don't even know it's communications. It might be part of a propulsion system.

So this is why it was so difficult for all these people that got a package to take this and try to figure out what it is. Yes, it was a big learning curve for the Germans and the SS, but they had the vehicles.

We just had paper and a couple of parts. I mean, it was very difficult for the United States with the top people in the country to take this and then come up with, "How do I copy this? How do I make one of those? What is it?"

* * * * *

David: So **Corey**, the first thing that jumped out at me in what we just saw was when he said that he was woken up at midnight, and that that was when he was taken up to have this meeting in which they're actually putting these so-called "packages" together.

Why do you think it was necessary for him to be woken up in the middle of the night to do this work that . . . I mean, wouldn't there be a secure room that he could go to during the day? Why do you think that was necessary?

Corey: Most likely it had to do for the security of the operative. They want to bring him in when there's a skeleton crew at night taking care of regular duties.

It's going to make it easier for them to sneak the person in.

David: So people don't see it. There's less espionage potential?

Corey: Right.

David: Okay. And he mentioned that some of what these people were able to get out of Nazi Germany, these – he didn't mention the number, but it was 23 embedded spies – he's said that before – all throughout World War II – included photographs of people, soldiers, I guess, standing in front of UFO-

type craft that could be anywhere between 50~240, I think he said, feet in diameter.

I'm curious as to whether any of those documents survived and whether you got to see any of them while you were in the programs.

Corey: There were stuff like that all through the glass pads. But sort of like how he was describing, a lot of the information, it wasn't contiguous. It was kind of just haphazardly there.

You'd go through a lot of information that I didn't understand. There would be photos. There were many photos of Germans and craft.

David: He also mentioned hieroglyphics. And that might be something that our viewers were wondering why that would have occurred. What would the hieroglyphics be?

Corey: The hieroglyphics could be a security code, but in this case, it sounds like no one understood what they were. So they were most likely nonterrestrial script of some sort, iconography.

David: So this could be something that a spy maybe had a spy camera and took a picture of something that was on an extraterrestrial craft. And maybe he even didn't know what it was, but he's just smuggling out that intel? Something like that?

Corey: Right. Yes. Lots of bits and pieces. Back then, especially, there was no computer terminal they could go to and download things to a thumb drive and then go back to their superiors. They had to be very careful. But they were just getting little bits and pieces.

And they would have like a diagram. The diagram they would bring back; they would give to the people.

And if they didn't have anything to add verbally about what the diagram was about, they would have to reverse engineer just a diagram.

David: Are there extraterrestrials, to your knowledge, that would use some type of hieroglyphic language?

Corey: Yes. Most of the written languages are a type of glyph or looks like hieroglyphic. And one character or symbol can mean different things depending on the context it's used [in]. And one

character can mean quite a bit.

We're pretty limited in using just one character at a time.

David: Sure. He mentioned that some of the groups that were getting these packages were biomedical. Why do you think that would be?

Corey: Well, the Reptilians handed over genetics to the Germans very early on. I think . . .

David: I'm not sure what you mean by that.

Corey: Well, when supposedly DNA was discovered like '53 or '56, something like that, well it, actually, was well-known in the programs, and scientists were using genetic engineering way before we supposedly discovered it. And they were testing it on soldiers a lot of the time.

David: Do you think that part of this biomedical packaging could have been in the development of cloning technology?

Corey: Absolutely, yes. We were giving cloning technology for creating – just like out of “Star Wars” - creating a force of soldiers that could be used as cannon fodder. That if you were to lose a few thousand of them, it wasn't going to be that big of a deal.

David: Is this something that basically kind of allows you to print an organism, like you don't have to wait for it to gestate and grow into adulthood over the course of 20 years?

Corey: Well, they're growing these things also in these temporal fields.

David: Right.

Corey: And they can make it look like a little zygote grows up into a full grown human in a couple of hours.

David: Wow!

Corey: But the zygote in the field is experiencing 20 years.

David: Right. Time acceleration.

Corey: Right.

David: Another thing that I think some people, maybe like the nuts and bolts, meat and potatoes, UFO researchers like your Richard Dolan types, would maybe stammer on a little bit was when he said that the documents were not stamped “Classified”.

Corey: That's common. That's how you disavow information.

David: I don't understand.

Corey: Well, let's say he got in a car wreck on his way to deliver a package, and he was unconscious. And someone happened to go through his car, found this package.

It would just be some very interesting and strange information to him.

If it was stamped “Top Secret”, or any of the other indicators, then it's going to legitimize what is in the package and legitimize it as being an intelligence briefing.

So many intelligence briefings are delivered without any type of classification at all.

David: Were a lot of the documents that you saw in the glass pads not stamped “Classified”?

Corey: I rarely saw any stamps like that.

David: Really!

Corey: There would be like date stamps with signatures and different things like that, but I didn't see a whole lot of “Classified” or “Top Secret” stamped on them.

David: So then why would they stamp any documents “Classified”? Is that where more people are going to be handling them and they're worried about leaks?

Corey: Yes. You stamp things for management purposes, for people managing the documentation.

“Oh, I need to handle this with care, because it says 'Handle with care'.”

David: Right. All right. So now we're going to have another segment for you. And in this case we're going to get into the dissolving of the official Nazi government as it was at the end of World War II and the interesting historical question of what exactly happened to these people who had access to

extraterrestrials, highly advanced technology, and all of this knowledge that could be applied to what later became the Secret Space Program.

* * * * *

WHERE DID THE GERMANS GO?

William Tompkins: By the end of the war, Germany had already removed massive, not underground, in mountain. This word 'underground' shouldn't be used. All over Germany and the occupied countries, Germany was building mass production of a dozen different types of extraterrestrial vehicles that were given to them by the Dracos. Okay?

So these are in mass production, not just prototypes kind of things. They've gone into mass production using slave labor with hundreds and hundreds and hundreds of in-mountain massive facilities.

80% of that had all been removed from Germany six months before the war ended. It had all been taken to Antarctica, and they were continuing the construction down there.



They had access to these with their submarines.

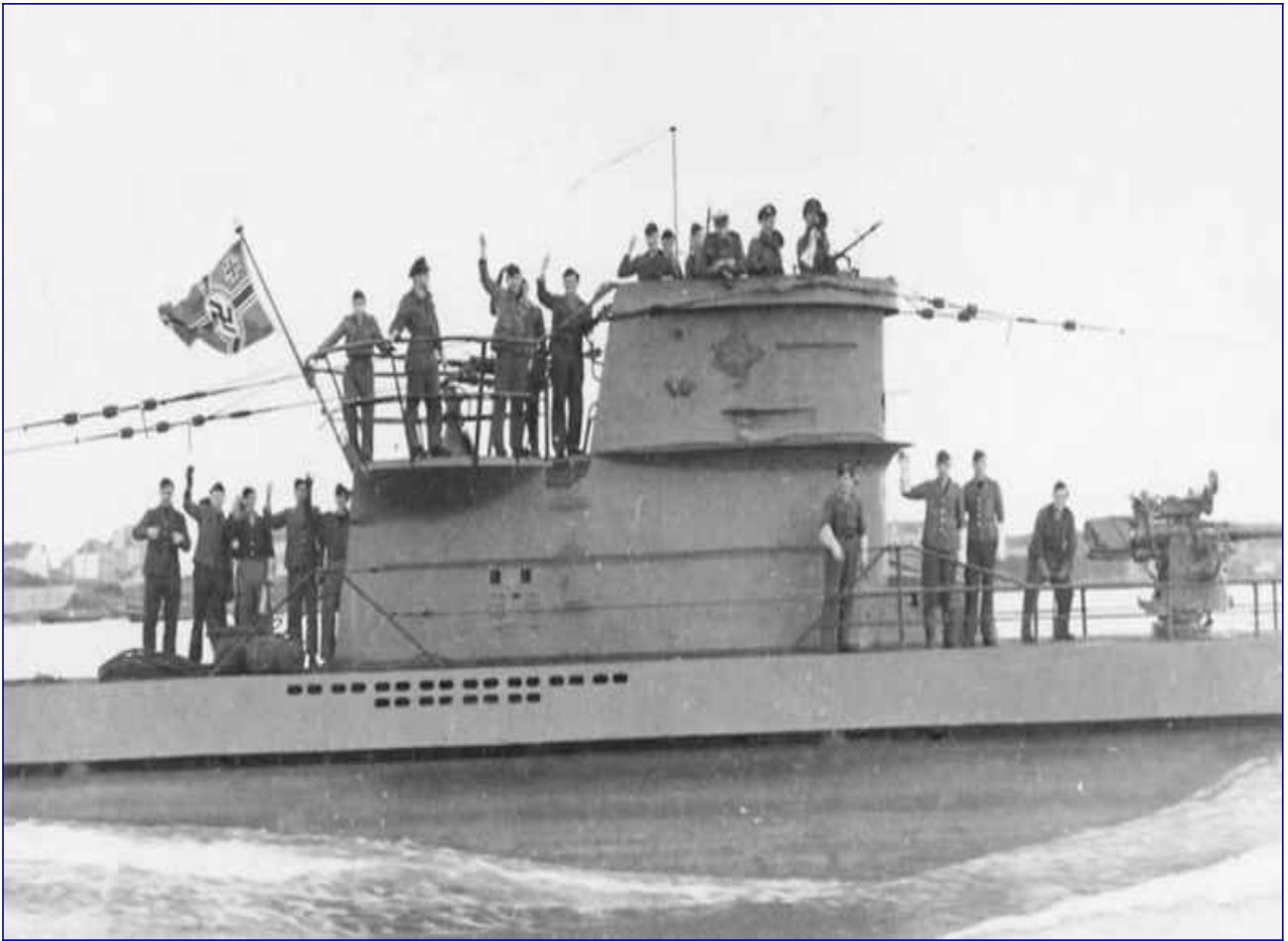

The built massive truck submarines, enormous submarines, to bring all this stuff down to Antarctica.

So the submarine, still submerged, goes through these tunnels. They go back through the tunnels, and they get to a lake where there's all these facilities and the cities and naval bases and towns and thousands of people.

And so Paperclip, we got the different people, and they certainly helped.

They came in and sort of took over all of the aerospace companies and all of the biomedical research companies. Okay?

And actually the Apollo vehicle was just one of the studies of the German ICBM bullets to have been used against New York and all the big cities in the United States.

They just hadn't gotten that far by the end of the war.

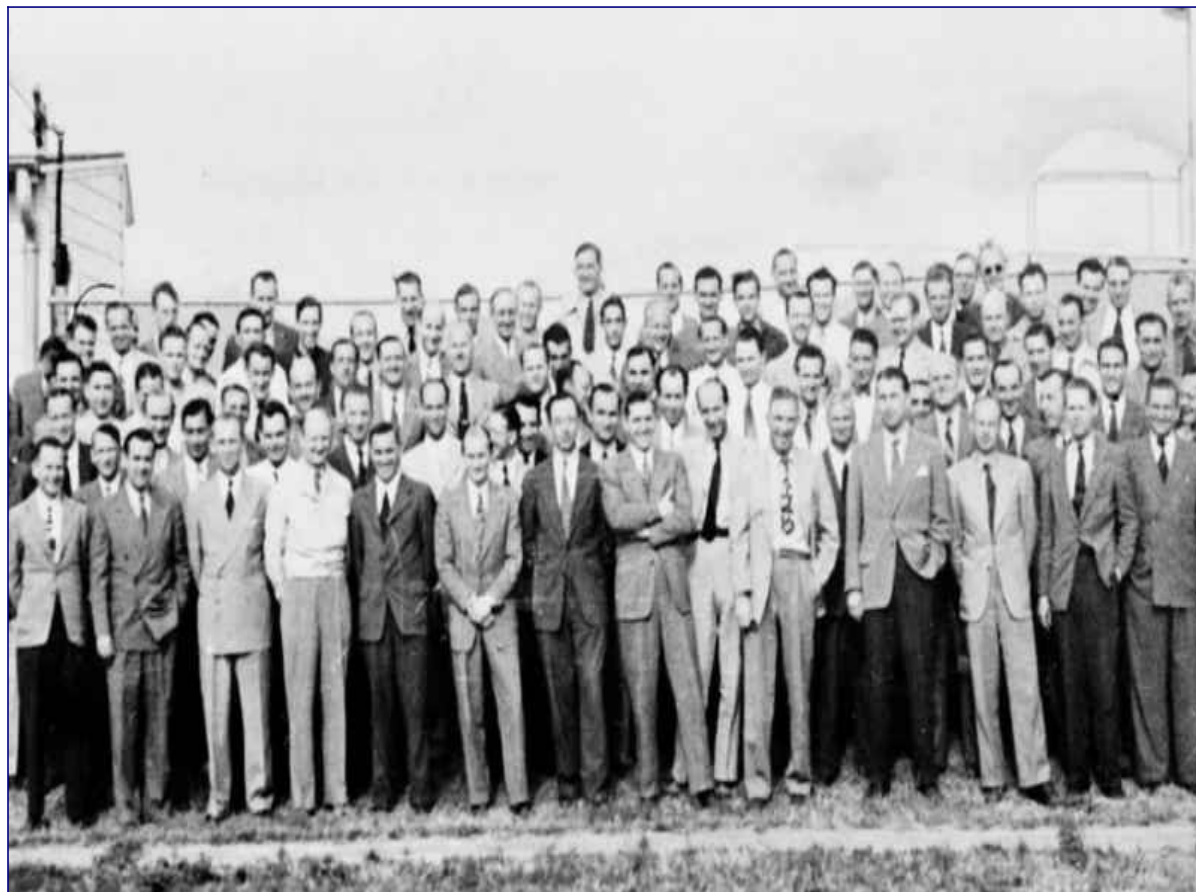





The German biomedical research people came over with Paperclip, too. And they set up operations in, for instance, Scripps Research, medical research, and eastern research companies.

They went and worked for them. They got jobs working for them, and then they started to come up in that organization. And then they took over the operation and were then very skillfully and diplomatically implementing many of these medical analysis, which are of extraterrestrial civilization people's history, which they have been doing this out in the galaxy for thousands, hundreds of thousands of years.

They may have only recently come here, but they've been involved here for over 6,000 years. And we're just now looking over this fence, holding on with our fingertips, and looking out there and figuring out what's going on.

It's really about where we are.

* * * * *

David: He said that there were hundreds of production facilities. And he shied away from the use of the word 'underground'. He said 'in mountains'.

He said hundreds of facilities often involving slave labor in which these advanced Draco craft were being manufactured.

That's a shocking statement. And I'm curious as to whether you can independently corroborate that from what you heard.

Corey: I don't know about hundreds, but there were a large number of these types of cavern-type bases inside mountains in occupied Europe.

I had not been told that they were given to the Germans by the Draco. I was told that this was all a German operation, that they had dug out . . . I mean, these were dug out tunnels that they used slave labor to do. These caverns, . . . they were chiseled out.

David: One of the things that I really thought was interesting about this relates back to what war are the Nazis actually fighting? Because none of these ships actually appeared in World War II to any

significant degree except for maybe the occasional sighting of Foo Fighters that American pilots were seeing in World War II.

So why do you think the Germans in the middle of World War II are so busily developing a technology that was not being implemented by them in World War II?

Corey: The Draco wanted them to build these vessels to fly alongside the Draco and do battle.

David: But where?

Corey: Out in space.

David: Okay.

Corey: They're turning over this technology, to the Germans at the time, for a purpose. And they have to operate within those guidelines.

David: "They." Who has to operate within the guidelines?

Corey: The Germans. When they receive this technology, they now have to operate within certain guidelines dictated by the Reptilians.

And the Reptilians, they manipulate a lot of the surface stuff going on, you know, wars, and that kind of a thing. It's more of a management, planetary management, thing for them.

They're more concerned about conquest outside of our planetary sphere. And they are known for having conquered races fight alongside them.

I've mentioned the tall Nordic looking group that has the large forehead, six fingers, that are often seen in our solar system working alongside the Draco.

And it's been postulated that they are like what the Dark Fleet is to our planet – a group that either was conquered or made a deal with the Reptilians and then started fighting alongside them.

David: I can't help but be intrigued by this quote based on a class that I had in college that had a deceptively simple name, Contemporary Social Issues, but it was a class in government conspiracy.

And it explained – my professors explained to me in that class – Hitler's tanks were made by Ford Motor Company. Hitler's jets were actually made by Boeing.

And when the plants were bombed in Germany, they were repaid by these allegedly American corporations, who were allegedly fighting the Nazis, to rebuild those plants.

So it almost sounds to me as if the American industrial side was covertly building the war material for both sides of World War II, but then the Germans are involved . . . What they're really concentrating on is this other stuff that's for a war that's not even about World War II at all.

Corey: Correct. Right. It was a much more cosmic operation than the World War that was occurring on the planet.

David: So were the Draco concerned about whether the Nazis won or lost World War II?

Corey: These beings, they play the long game. The war may have served a purpose for them. Whether it was won or lost, you know, we're thinking from a human perspective. They play the long game.

Each of these things they use to set up the next thing. So it sounds to me like they were trying to get the Germans, . . . the World War II situation, . . . put the Germans in a spot to where they needed the help from the Draco.

They were starting to lose. They knew from the beginning that once the Americans got in, that it wasn't going to go well.

So the Germans, they had an agenda, but the Draco or the Reptilians had a much larger agenda that this was just one tiny little piece of.

David: So when he starts to describe the dissolution of Nazi Germany under Paperclip, which, of course, is Project Paperclip, the transfer of German scientists, what happens with this biomedical stuff he's talking about?

He's talking about them going out there, but then he clearly said what appears to be almost like the origin of the whole pharmaceutical corporate industry is being run, secretly, by these transferred Nazis.

And so I'm curious as to what might be the agenda for Germans from World War II building a pharmaceutical corporation, which, according to what **Tompkins** said, is now the origin of Big Pharma in general.

Why would the Fourth Reich be controlling Big Pharma? What's the purpose?

Corey: When you have control of pharmacology, I guess, you can . . . I mean, people are so trusting of a pill.

Who knows what exactly that pill is actually doing to us? Is it helping suppress our consciousness?

I don't understand why they are doing it. I don't know the specifics. I think it's a multiple agenda-type program.

David: So do you think that part of the suppressed science might be that there are natural remedies for certain things that the pharmaceutical industry poses as if they are the only answer for – such as depression, ADD, things like this?

Corey: Absolutely. The planet provides us everything we need for medical, psychological, trauma healing. It's all in the jungles that we are burning down.

And that might be one of the main reasons we're burning them down.

David: All right. Well, that's all the time we have for in this fascinating episode. I sincerely hope that we get to the point in which this is a forensic document that is absolutely essential in the process of Full Disclosure.

And I thank you for being here on the vanguard of that social and cultural awakening with us here on Gaia.

I'm [David Wilcock](#) with **Corey Goode** and **William Tompkins**. This is "[Cosmic Disclosure](#)", and we thank you for watching.

Cosmic Disclosure: Antarctica: The Process for Disclosure

Season 7, Episode 8

David Wilcock: All right, welcome back to “Cosmic Disclosure”. I'm your host, **David Wilcock**, and we're here with **Corey Goode**. **Corey**, welcome back to the show.

Corey Goode: Thank you.

David: So in our last update we had just gotten up to the point where the dark priestess of the underworld, Marra, had materialized in your room, was acting very sarcastic, as if she had complete control of the situation, and was then portaled back by the Anshar and put in stasis, but they did give you a warning, right?

They said that others like her could show up.

Corey: They stated that there would be some of her kind coming to look for her.





David: Okay. Meaning that they might also visit you as well and you'd have to defend against them.

Corey: Right.

David: Let's go from what happens next.

Corey: Sure. And for the record, none of Marra's people have approached me since then.

David: Okay.

Corey: It's been fairly quiet.

Most of my experiences have now been with this MIC SSP.

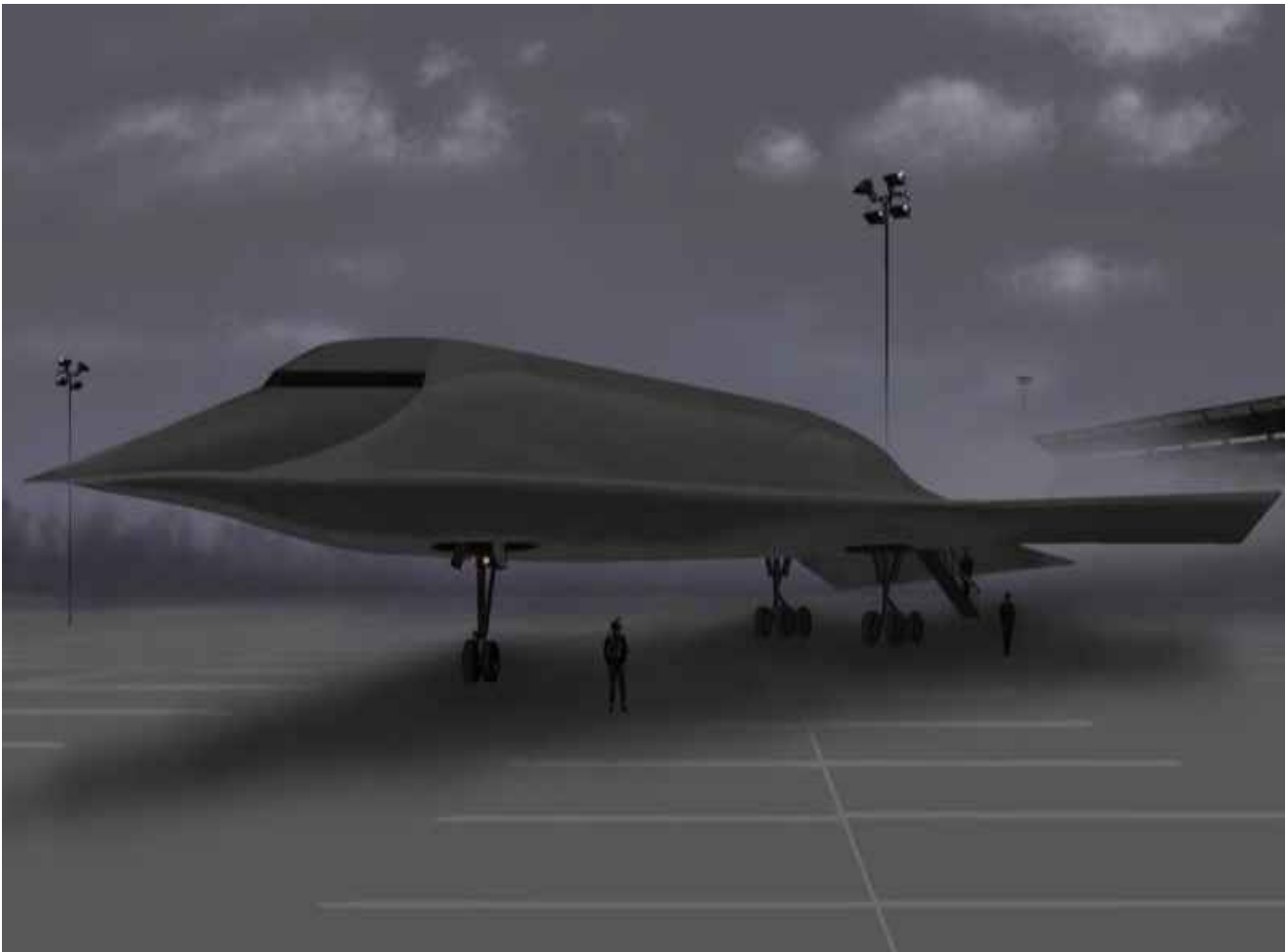

I've been picked up a number of times, and in the meetings I've been giving [given] no-questions briefings by the two airmen that had assisted me up and down the stairs of the craft.

David: And that means you're not allowed to ask questions?

Corey: No questions. You just sit there and listen. They were filling me in on more information about Antarctica, what has been discovered down there, how it's being processed, how they plan on presenting it to humanity in stages . . .

David: Okay.

Corey: . . . as well as I was having meetings with who we call Sigmund – the commanding officer. And he has also been sharing interesting information with me, some of which I can't even discuss because it has to do with upcoming meetings that I'm going to have – more of a terrestrial nature.

David: Okay. So, then we've covered the thumbnail of that. Have you also been having Anshar meetings? And if so, what's the jest of those?

Corey: I have had a number of Anshar meetings. A lot of them, Ka 'Aree also preparing me for upcoming terrestrial meetings I'm going to have, letting me know that she's going to . . . for me to not be so nervous. I'm pretty nervous.

She's letting me know that she's going to help me in the process. She's going to be giving me information to communicate.

I've also been picked up one time by the Anshar and taken down to Antarctica.

David: Okay, so when we last spoke on this show, we had discussed the idea that there was interesting stuff going on down in Antarctica, but we hadn't really gotten into this big thing that you were withholding from me. You couldn't even tell me, and we couldn't talk about it on the show.

And that's where our "Endgame II" update begins. So what was the information that you were getting for months that you couldn't tell me and you couldn't talk about on this show that we're now cleared to talk about? What's going on down in Antarctica?

Corey: Well, according to Sigmund's men and Sigmund, they have made major discoveries. In 1939, the German expedition to Antarctica had discovered big slabs of rock with ancient writing on them, and they had taken a bunch of photos with them. After that they started a lot of secret expeditions.

David: So these are things that would remind us of stuff like Stonehenge or the pyramids or something like that?

Corey: A little more like Pumapunku or something, you know, that's really torn up and scattered.

David: Okay.

Corey: So after the Germans had discovered this, they started to, not really excavate for archaeological reasons, they started to clear out areas and begin to use them that they found. They found in cave areas ancient civilization artifacts, and they just moved them out and moved their military groups in and created bases.



So they weren't real interested in the archaeology in the beginning, which sounds not very much like the Nazis since they had archaeologists combing, you know, . . . combing Asia looking for certain . . .

David: Especially groups like Black Sun and Vrill where it seems like they are very interested in this ancient history.

Corey: Right. It seemed mission was to hurry up and build this base. That was the primary ob . . .

David: Well, the clock was ticking and they knew that they were not going to be able to pull through on World War II.

Corey: Right. So they had been looking into it, doing some digs here and there, over the decades leading up to where they ended up working with the Americans, the industrial complex, military-industrial complex.

They were doing excavations all throughout the decades going all the way back, you know, from the

'50s and '60s.

Now, since then, in around 2002, they started bringing in actual professors and archaeologists from universities. And these are some people that we would know if you're into academics. These are people that we will know that have been going and doing digs and research in Antarctica.

And these people have been told that . . . you know, that's 14 years of research they can't tell anyone about.

And they've been promised that they are going to be brought out in front of the press and allowed to give a briefing and present the documentaries they've made and all of the information they've collected to the people.

David: And one of the stunning things was that you were being told we had to write “Endgame II” as fast as possible.

Corey: Yeah.

David: And two hours after it comes up, tabloids like the Mirror and the Sun, start repeating this same data that we were getting.

And then the next day after we put the update up, one of those same tabloids, I believe it was the Mirror, actually said that there was a team of scientists that had been in Antarctica since 2002, which you had already told me on the phone.

I hadn't remembered to put it in the article, but you had already briefed me on that.

Corey: Right.

David: And then there it is in this frickin' tabloid. And that to me was just so amazing the level of public confirmation of this stuff.

Corey: Right. I was being told that we were going to get scooped, that we had to get the information out immediately.

David: And so you were being told before that came out that, in fact, they had been there since 2002.

Corey: Yes, and what they were finding there is what blew my mind even. They were finding ancient technology that . . . They were finding spacecraft that had been cannibalized to create a new civilization, cities, and so forth.

They found areas that were laboratories for genetic experiments, which apparently genetic experiences had run amok among these Pre-Adamites.

We were finding all types of different humans around, even humans with tails, short humans, tall humans, all different types of humans, along with this original Pre-Adamite being that crash-landed here somewhere between 55~60,000 years ago.

David: What is a Pre-Adamite?

Corey: The alien group, non-terrestrial group, that once inhabited Mars and Maldek, after there were catastrophes mostly from their own doing, and war . . .

David: This was half a million years ago.

Corey: Right. Half a million years ago. Then they end up on the Moon for a period of time.

And then somehow they ended up getting chased off the Moon. There were some attacks that occurred, and after that they fled, but their craft were too damaged leave our solar system or make it to another planetary sphere.

So since they had to crash-land on Earth, they decided that they would go to this one continent that still had working Ancient Builder Race technology that was . . .

David: How old are we talking now?

Corey: The information that was given to me was 1.8 billion years old.

David: What do you mean by technology?

Corey: Well, they only had the technology that they had on these three craft with them. That's all the technology they had.

So they had to cannibalize and repurpose that technology from the spacecraft once they had crash-landed. And there were three that were extremely large. They were motherships.

And they were referred to as the Nina, the Pinta and the Santa Maria.

David: So just to be clear, it's not that there's any actual name connection, it's just that Columbus's three ships were called the Nina, the Pinta and the Santa Maria. So it's kind of like a tongue-in-cheek joke. You have three motherships that crashed on this continent.

Corey: Right. And they have several of those tongue-in-cheek references in this report.

David: And I want to point out, that this was one of the absolutely stunning details in which I start to ask **Pete** [Peterson] on the phone, “Do you know anything about Antarctica?”

And he independently says, “They're going to announce that they found a mothership.” He only knew about one – a mothership that was 30 miles wide, mostly circular in shape – that's been found under the ice.

Corey: Right. And so far they've only exposed the area about the size of an ocean liner. But in doing so, they've gained access to one of these ships.

And they've been going in, flying the craft around that were inside it, checking out . . .

David: Wo, wo, wo. They went inside this 30 mile-wide mothership, and they found craft inside the mothership?

Corey: Yes.

David: And they've been able to fly those craft?

Corey: Yes.

David: In the mothership or also outside?

Corey: No, outside. Out of our atmosphere even. They found a number of different types of craft that had different uses, one of which was a very ornate craft that was sort of stupa-shaped.



David: Like the Tibetan shine that we see so often.

Corey: Right. And they were referring to them as vimanas.

David: Really?

Corey: Inside the program, they were calling them vimanas. Whether they are or not, I don't know.

But these were only for transporting around the royals. They were different than the other craft. They were decorated and had gold on them and were very ornate.

David: And you said that the beings that were inside these craft were Pre-Adamites, but could you just give us a description of what that means?

Corey: Yes. They range 12~14-foot tall. They have elongated skulls. They were very spindly, thin.



David: Like Akhenaten, Nefertiti and their children, such as Meretaten.

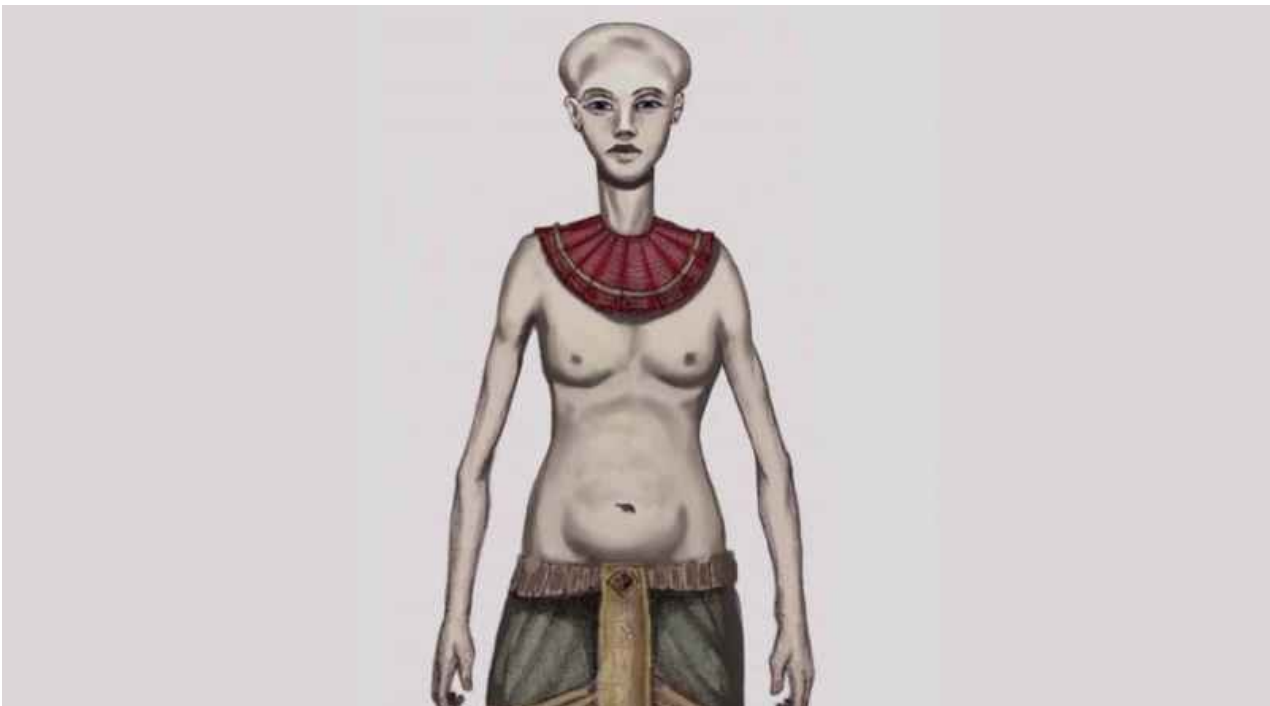

Corey: Right. And the men had a flabby pocket on their chests – kind of a flabby chest.

And these beings, they've . . .

David: What about skin color?

Corey: The skin color was hard to tell because they had been in a huge cataclysm where they had . . . Some of the bodies, their arms were wrapped around them a couple times. There were big black spots on the skin. They had been under the ice.

They weren't preserved like you see in the movies like an iceman that you can re-animate.

And the biologists that have studied these bodies, done postmortems on them, have said that these are obviously beings that had developed in a much different environment than ours – a lower barometric pressure and gravitational field.

David: Who do you think, or who were you told, shot them down when they made it to Antarctica?

Corey: Apparently these Pre-Adamites have been in conflicts with the Reptilians for awhile. These Pre-Adamites they stated were not good guys at all, but were in some sort of a conflict with the Reptilians, and had actually kept the Reptilians in check here on the Earth during that time that they had crash-landed here.

There had been a couple other smaller catastrophes that happened where they had lost their power and the Reptilians always find an opportunity to come back in in a moment of weakness.

David: So does it appear then that wars between Pre-Adamites and Reptilians occurs almost from the beginning of when they got here?

Corey: Exactly.

David: Okay.

Corey: But after these cataclysms that occurred on Earth, the Pre-Adamites and the Reptilians sort of had a truce or a treaty. And after that point, the Reptilians pretty much controlled all of Antarctica and

the Pre-Adamites had zero ability to get access to their ancient technology, their libraries. Everything was down there.

David: Right.

Corey: The people that survived the cataclysm were mostly the genetic experiments. They had created hybrids because they could not operate in our environment very well. And they created hybrids of them and the humans that were here on Earth.

So after the cataclysm, all of the main Pre-Adamites that were pure blood were down in Antarctica when it occurred.

There was a group of these Pre-Adamites, of this Pre-Adamite bloodline, that was in the Central America, South America region, and there was another completely different bloodline group – both royals – in Asia and Europe.

David: Now, when we're looking at the descendants of this original civilization, you said that they came here in three motherships. So I just want to be clear that these are the 30-foot wide motherships that we're talking about.

Corey: Thirty-mile.

David: 30-mile wide. Is that the largest type of mothership that they had?

Corey: No, they found other ships down there as well that are fairly large, but would be like sort of another . . . just a smaller vessel in a fleet.

David: So it's just that there's three big ones but there are other craft as well that were found.

Corey: Exactly.

David: I want to get into the connection to biblical scripture because one of the scriptures that's from the same time as the Book of Genesis, the Book of Enoch, was removed from the Bible but it's referred to by Jesus. It's referred to by a variety of people from that era as a very, highly revered text.

And it describes 200 fallen angels crashing to Earth, being giants, and then becoming cannibals who are actually hostile to Earth's population and were ultimately judged that they had to be wiped out in a

big flood.

It sounds like we're talking about the same thing here.

So what's the connect with the Book of Enoch?

Corey: It is and the information that I received was that these Pre-Adamites had come down in a . . . they were in the grand experiment.

They shouldn't have been down here living openly amongst us, one. And two, they were now . . . You know, the other 22 genetic experiments that these genetic farmer races were conducting down here . . . this Pre-Adamite group started co-opting it and interfering with it. So they had to be dealt with.

David: And just in case somebody's jumped in and they didn't see those episodes, you described that when the protective grid [built by the Ancient Builder Race] went down 500,000 years ago after the planet [Maldek] blew up and became the Asteroid Belt, that we then have right away these so-called genetic farmer ET races that are then able to get in immediately and begin taking DNA from all over the galaxy and tinkering with Earth DNA.

Corey: Yes. And as we have been exploring more and more of the ruins down there, we've run across rooms that were . . . There were a series of corridors that were sort of arranged the same way you would see a circuit board.

And they were made out of a gold-copper alloy that had weird kind of circular carvings in them that they said were not for people to walk through. It was obviously for channeling large amounts of electricity.

Not far from there, they found the genetic labs where they found all these different types of beings in different stages of being developed.

And I did confirm that it was partially technological, partially biological, how they did these genetic experiments. They would create a zygote, or whatever, and then implant it in another . . . in a human or an animal, have it grow, and then that's how they incubated them.

They didn't have all of their technology. They were in survival mode from the moment they crash-landed.

They had to cannibalize all of their technology from inside of these craft, these big motherships. There's huge areas where stuff has just been ripped out.

David: If they're trapped on Earth, because they crash-landed, but then you say that there are craft that were found inside that can be flown around, doesn't that mean that they could have left Earth and gone anywhere else they wanted?

Corey: Well, yes, they could in the craft, but everything that they . . . all of what they had left of their society was now down here on Earth. And these craft are not long-haul vessels.

The little craft that they have are for, you know, scooting around the solar system. They were stuck here in the solar system.

And of the 22 different genetic farmer races, we have the Reptilians, and it's a hostile place for them to try to fly around. Their numbers were small. They were not in a good tactical position.

David: So they could theoretically visit moons of Jupiter, moons of Saturn, places like this, but they didn't have enough duration of fuel, let's say, or whatever travel capability, to actually leave our solar system.

Corey: Correct. Right. And it was pretty hostile out in space during that time. They didn't want to risk an asset like flying it, you know, to Jupiter or whatever. They could lose that asset and they had very few assets left.

But this civilization controlled the entire planet. What little resources they had, they were able to control the planet.

After this last cataclysm occurred, none of the survivors, Pre-Adamite survivors, had access to their technology.

So we mentioned the group that was in Asia, Pre-Adamite group, and there was another one in South

America, Central America, they could no longer visit or communicate with each other. They were separated.

David: After the conventional Atlantean catastrophe we're usually thinking of.

Corey: Right. And they had always had some sort of a competition between these two bloodline groups even before the cataclysm.

This whole bloodline of these Cabal or Illuminati-type people, they trace their bloodlines through these Pre-Adamites.

David: So in the Book of Enoch, they're describing this group as the fallen angels.

Corey: Uh-huh.

David: So you're saying these Pre-Adamites with the elongated skulls, that that is the fallen angel storyline.

Corey: It is the fallen angel storyline, yes.

David: But we do have this Cabal, and this is one of the things that our insider Bruce has been saying, whether or not you believe this or not, the only thing that matters is that they do.

Corey: Exactly. Their religion is what . . . I mean that's . . . Their religion is everything. It's behind everything they do.

David: Where do we see this Pre-Adamite culture developing? Where did they hide out in the Americas after this catastrophe?

Corey: In South and Central America is where they had set up most of their enclaves. And they had been set up around other Pre-Adamite structures that were now destroyed because of the cataclysm.

There were huge earthquakes that basically liquified the ground and a lot of the buildings, massive buildings, they had just fell apart and fell and sunk into the ground.

They were running the hemisphere. They were mixing their genetics with some of the indigenous people of South and Central America. That's why we have elongated skulls beings that have a different

colored skin but different genetic mix.

They were mixing their genetics with whatever group they happened to be around after the cataclysm.



And going back to the Illuminati religion being based on a lot of what this group did, the Pre-Adamites, you can now see why all of these interesting people have been making trips down to Antarctica recently, including Kerry on election day.

David: Right.

Corey: And even some of the royals have gone down there.

David: And now I'm speaking about the idea of some very interesting cargo that was found in those motherships. So could you describe what this precious cargo was that they still had on those ships?

Corey: Well, they had a number of beings that were in stasis. The information I received was that the surviving Pre-Adamites, the bloodline that originally came from another planet, had put themselves in stasis before this cataclysm occurred about 12,800 years ago.

They have not awoken them yet. They're trying to decide what they're going to do.

Now, another interesting note, we do have these archaeologists and employees of various universities that are down there excavating and documenting all of this, but what they have done, they being the Cabal, I guess you'll say, they have used these large electromagnetic submarines that I discussed earlier to take a lot of archaeological items that they had found in other digs that they were keeping suppressed from humanity, they had them in huge warehouses.

They were taking some of these artifacts down to Antarctica and seeding them. And this one large dig that these archaeologists are going to make public.

They are also removing any body that does not look human. And a lot of the human bodies, they don't look like they were slaves. They have tunics that have gold thread weaved in the tunics. They look royal.

So they're planning on giving us a sanitized disclosure, and then over time they will disclose the Military-Industrial Complex Secret Space Program.

And after they do that, they'll say, "Oh, by the way, yeah, we've got this fairly advanced Secret Space

Program, and while we've been out to other planets, we've found very similar ruins as we've found in Antarctica.

So they're going to try to trickle the information down over decades, and not immediately tell us about the ships they found and the high technology and non-humans.

David: You're not talking about necessarily something that you pick it up and it projects a holographic . . .

Corey: Out of place archaeology.

David: Okay.

Corey: They hide certain artifacts to keep the narrative alive of, you know, the Earth . . . we only have 6,000 years of civilization . . .

David: And you say that they're actually finding those genetic remains down there now.

Corey: Right. And a lot of the human, I mean like us, humans, that they found under the ice . . . and this was a . . . they'd obviously been hit by a huge wave that then somehow flash froze . . .

David: An ocean wave.

Corey: An ocean wave, yes. And all of the bodies were referred . . . They jokingly, tongue-in-cheek, referred to it as the "Pompeii on Ice" because of the way all of the bodies were found, some of them huddled together. It was very similar.

David: Could you describe for us what you have personally seen? Obviously, you're getting no-question briefings, but what have you personally seen of what you're talking about?

Corey: I was taken by the Anshar, in one of their egg-shaped craft, down to Antarctica. And Gonzales was with us.

When we were taken down there, Gonzales had this like a rucksack that looked like it was military, human military.



David: Okay.

Corey: And when we went down there, he was taking out this like a core sample thing that had a handle on it and a little camera on the end with a long . . . with these long needles . . . looking things . . . that twisted on.



And he was walking up to each of these bodies, taking either a picture or video, I don't know, and then sticking the core, the needle, in the body, twisting it, pulling it out, and then dropping the core sample in these little plastic test tubes, and then putting them in the bag as he went on.

David: And you say “these bodies” do you mean Pre-Adamite giants?

Corey: Pre-Adamite bodies. There were these hybrids I personally saw in a fetal position, a very short human that had a tail [**Corey** spreads his hands about ten-inches apart] – you could see the folds of the skin going down on the back and then the tail kind of twisted out and it was frozen. So he was taking genetic samples.

And in the meantime, just before this, the Inner Earth groups were . . . they took us through a wall that hadn't been excavated yet. You could just see just a piece of stone sticking up out of the ice and snow.



It wasn't far at all . . . there was an excavation going on. There were tall lights on tripods pointed down into pits, and they were excavating.

They walked us right through the snow and the wall, and this room lit up.



And the room was full of scrolls, books. I mean, it was obviously a library.

The two Inner Earth beings walked up to one particular area like they knew exactly where they were going, opened up this collapsible box basically, and then started grabbing these metallic scrolls and putting them in the box. They were taking them. And these metallic scrolls were like laser etched with symbols.

The stone was . . .

David: Are you saying that the scroll was metallic or that it was a metallic container for a paper-type scroll?

Corey: They were metallic sheets of metal rolled up.

David: Oh, sheets of metal rolled up.

Corey: And it crinkled as they were picking it up. It sounded similar to tin.

David: Uh.

Corey: And on them, you could see there were like laser-etched symbols, and they were removing those before they were located by the people doing the excavation.

I still don't know what was on the scrolls or the significance of them. But when we left, they took them with them onto the craft.

David: Thank you, **Corey**, and I want to thank you out there for watching us, supporting us here at Gaia and making sure that we are on a path towards Full Disclosure. Thanks for watching.

Cosmic Disclosure: Corroborating the Evidence with Michael

Salla

Season 7, Episode 9

David Wilcock: All right, welcome to “[Cosmic Disclosure](#)”. I'm your host, **David Wilcock**. I'm here with **Corey Goode**, and our special guest this week is Dr. **Michael Salla** from the Exopolitics Institute.

We're going to have a lot of fun with this. We're going to get into **William Tompkins** and some of the amazing research that **Michael** Salla has done in validating even further some of the claims that might seem pretty outrageous that we've been discussing on this show.

So, **Corey**, welcome back.

Corey Goode: Thank you.

David: Dr. Salla, welcome to the show.

Dr. **Michael** Salla: Thank you, **David**.

David: Your site is called “Exopolitics”, so it sounds kind of self-explanatory, but I'd like you to just start by defining what you consider exopolitics to be.



Michael: Oh, sure. Well, I was teaching international politics at American University in Washington, D.C. when I first came across this information about extraterrestrial life and repressed technologies.

And the more I looked into this and did my due diligence, I found out that this was very real.

And so I looked at, well, what is the appropriate term to describe this? And being in international politics, the obvious one was something to do with politics, and, you know, because we have exobiology, exoplanetology, so the logical thing was exopolitics.

So I began to do research on it since that time.

David: When we see people talking about Voyager 2 . . .



. . . and the little plaque that is etched in on that with the image of the two humans and then here we are, we're located here, . . .

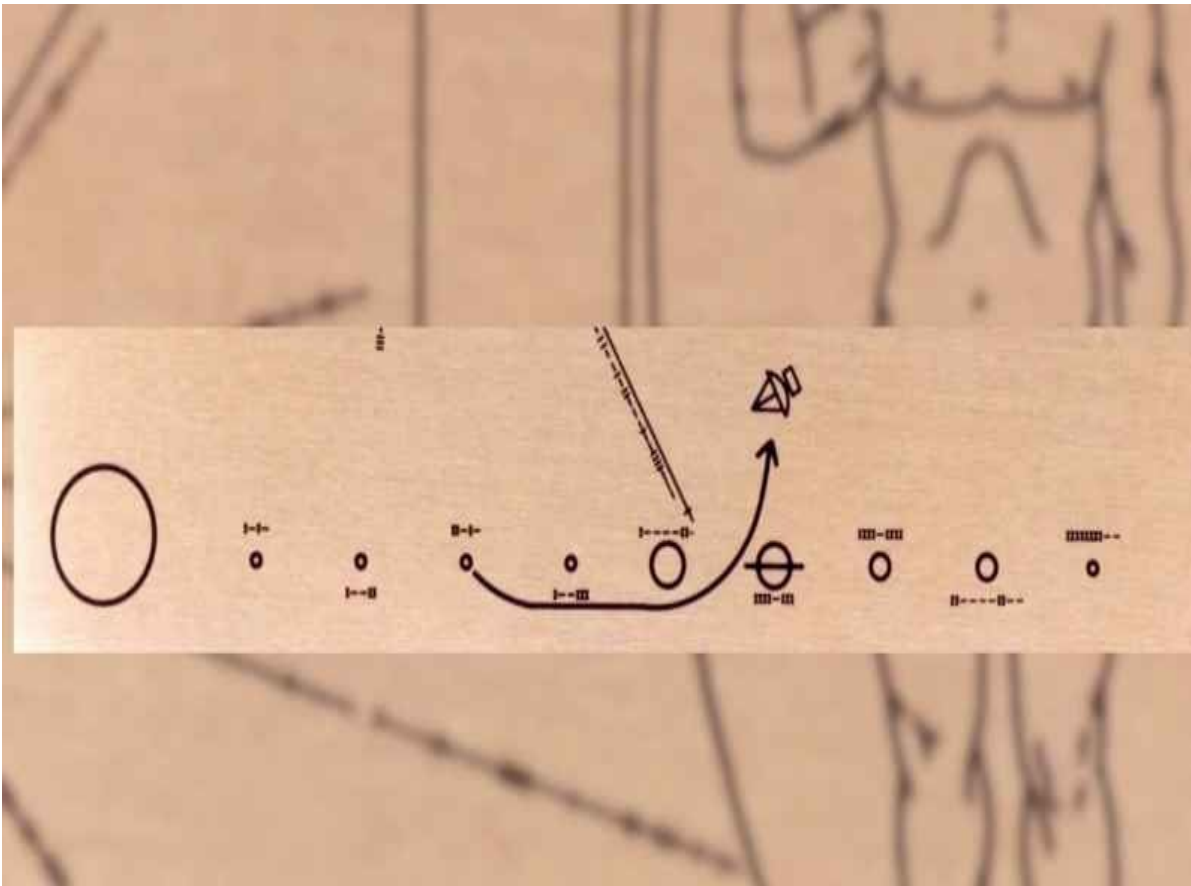
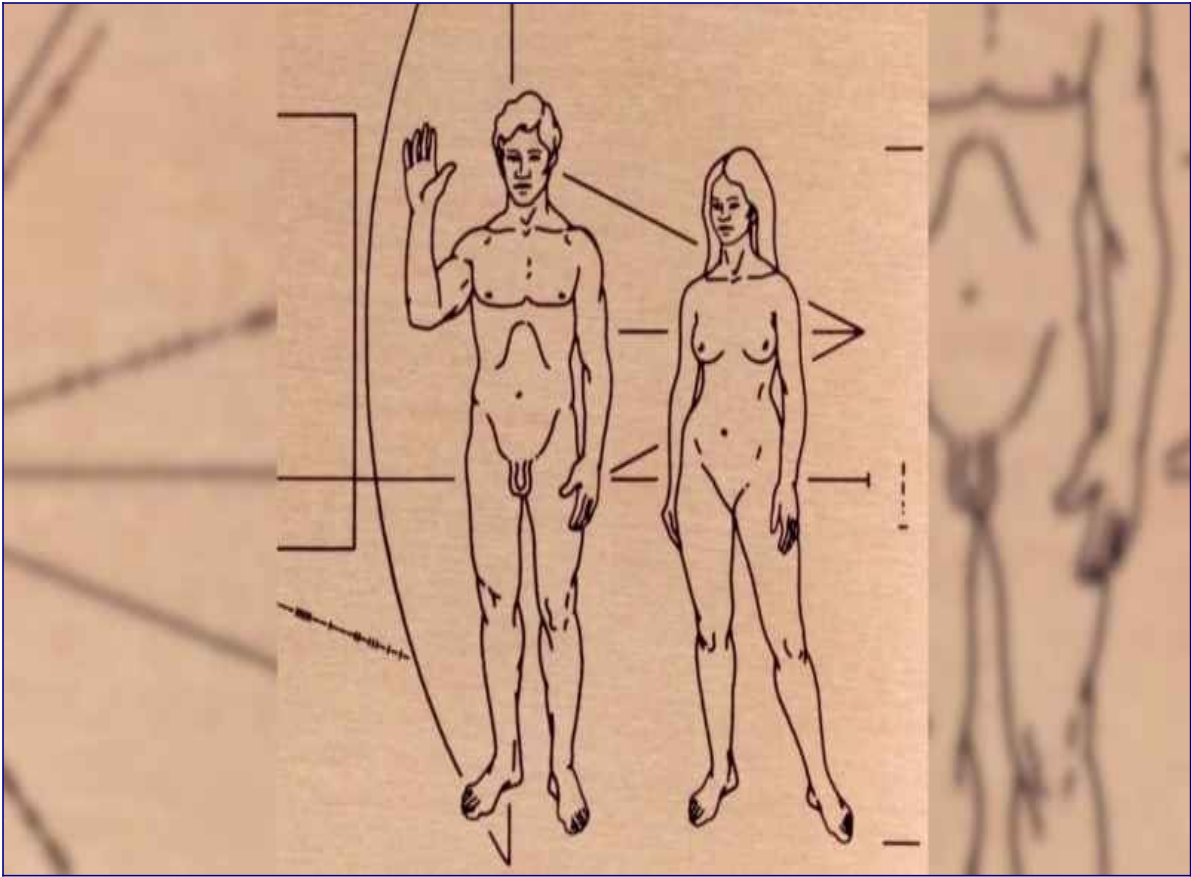

. . . has your research concluded that that might be unnecessary or redundant? Are we really alone, or have we already been contacted?

Michael: Well, definitely, when you look at all of the whistleblower testimonies that have come forward over the years and all the witnesses, people who have had experiences, it's not a question of, well, one day, will we discover extraterrestrial life or will they discover us?

We've been discovered a long time ago and that they're actually visiting and interacting with us, and it's all about just learning about who's interacting with who, what government agencies, what military departments are involved in this and the cover-up, and the extent of the cooperation.

That's the thing that most interested me, because I was always wanting to know – well, what is it that's driving international politics? And so the more we know about the agreements that exist, the more we know about what really is behind international politics.

David: And when we find out that all these decisions are being made without any voting, without any public approval, how have you positioned yourself in this dialogue with exopolitics?

Michael: Well, as a political scientist, I mean, what we really try to do is, you not so much kind of make value judgments about what policies are appropriate or not, but we just try to bring transparency into the whole issue.

Because the more things become transparent, the better decisions you can make about what should be done or what shouldn't be done. And then accountability. I mean, that's the key thing.

For political scientists, you're always looking at – well, how can we make people accountable? How can we make politicians, policy makers accountable for their actions?

And to make it possible for them to become accountable, you need to have transparency. So when we look at this whole extraterrestrial phenomenon, there's very little transparency.

So that means that people are doing things, making decisions that affect all of us without any knowledge on the side of the public or politicians, representatives that are supposed to be there kind of regulating this in some way, and zero accountability.

So to me, that's really the goal – to kind of bring transparency, to bring light to all of this phenomenon.

Corey: The lack of transparency, yes, being the problem, that's where the whistleblowers come in. Correct? And you've had access to **William Tompkins** for some time.

Michael: Right. Well, Bill **Tompkins** was very interesting because, when I first heard of him at the end of 2015, early 2016, I listened to some audio interviews about him, and he had incredible testimony.

And thankfully, I knew the key person that was involved in his book that actually came out in public in December of 2015 that is, “Selected by Extraterrestrials”.

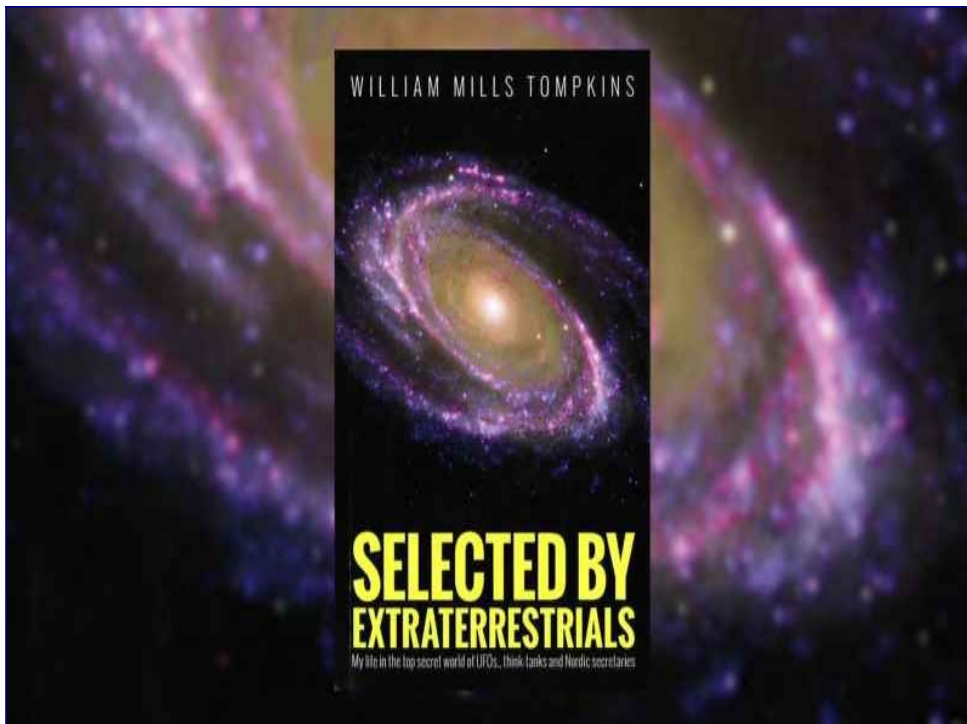

And Dr. Robert **Wood** was a colleague, and so I found him, and I said, “Well, how come you're working with this man, Bill **Tompkins**, who has this incredible story?”

And **Bob** told me all about Bill **Tompkins**'s history.

Corey: Yeah. **Bob** is known as a nuts and bolts guy.

Michael: Exactly.

Corey: Yeah.

Michael: And I've worked with **Bob** in the past in terms of validating certain documents, especially concerning the Kennedy assassination.

So to my mind, **Bob** is really one of the leading experts when it comes to document verification, especially when it comes to these secret projects.

So here he is saying that Bill **Tompkins** is the real deal, that he did work in this really highly secretive program that was run by the Navy, and then he worked in Douglas Aircraft Company for over a decade, and that his information was legit. So I then followed up.

I went down to actually interview Bill **Tompkins** in January of 2016 and did about 10 hours of video interviewing and really tried to get to the bottom of his story.

And then I went about the process of checking it out. Well, how valid is it, and do the people he named in his story really exist? Because what **Bob** would have done was he was able to validate the part of Bill **Tompkins**'s story in terms of him working at Douglas Aircraft Company for 12 years, from 1950 to 1963.

But what about his time at the Naval Air Station in San Diego? Did that check you? Do the people he named – are they real people?

And the one that was the most problematic was the admiral that was supposedly running this program, which, in the book itself, he actually misspelled the name of the admiral. So we had no way of checking out, well, did this guy really exist?

David: So **Michael**, when we're hearing videos with **Tompkins**, he says "Rick Obatta". And it sounds like the guy's name is Rick. So what was the secret that cracked this case, because I thought it was Rick, too?

Michael: Well, in the book, he refers to him as "Rick Obatta".

David: Right.

Michael: And so we couldn't find any admiral called "Rick Obatta", and so there was a breakthrough then eventually.

What happened was that it turned out that his name was "Rico Botta, B-O-T-T-A.

David: Right.

Michael: So once we found his real name, then we were able to kind of track down some biography on him and found out that, yes, this guy really did work for the Navy, that he was an admiral, and that he was in charge of the Naval Air Station in San Diego.

But what was really . . . I found fascinating was that, as we were trying to confirm whether or not this admiral existed and we found the name Rico Botta, but it was like, well, what do we know of him? There was nothing on the Internet about him.

So then just at that same time, in March of 2016, magically, on this Navy Aviator's website called "The Golden Eagles", there was a one-page biography of Admiral Rico Botta. It just appeared like that – out of nowhere.

It was almost like we were being helped . . .

Corey: Right.

Michael: . . . by people inside of the Navy that wanted to give us some assistance.

Corey: Exactly. Right.

Michael: Because prior to March of 2016, there was absolutely nothing on the Internet about Rico Botta.

Corey: That's very possible since **Tompkins** is a sanctioned disclosure.

Michael: Well, that's right, that **Tompkins** is being helped. And to me, that was a really powerful confirmation that there are people in the Navy that want his story to come out.

Because once that one-page biography came out, then we were able to do due diligence in finding out

more about Rico Botta, about his history, what Navy departments he was involved in after the Naval Air Station in San Diego.

So that was a big breakthrough because really confirming Rico Botta was the key in that part of **Tompkins's** story where he worked at the Naval Air Station in San Diego.

David: Well, **Michael**, I'd like to back up a little bit because, as a prominent UFO researcher, you are really one of the only people in the field who has broken ranks and stepped up and actually believed **Corey's** story to be credible.

Now, what was it for you that made you feel that **Corey** was credible?

Michael: Right. Well, one of the things that really kind of helped me was to see how his testimony was so consistent and how his body language was so consistent.

And when I first began to kind of communicate with **Corey**, back in – what was it – 2016, early 2016 – no, 2015.

David: Yeah.

Corey: That's right. '15.

Michael: Yeah. Early 2015. We did some email interviews. I think we did about a dozen or so like that.

Corey: That's right.

Michael: And so **Corey** was responding to questions, and so I would read his responses to those questions and put those out for the public so people could read what **Corey** was saying.

And so that was really very helpful because then we could see how his questions in these videos matched the questions that he had written down.

Because when you respond in writing, you know, you're accessing a certain part of the brain.

Corey: Right.

Michael: Your left brain. And when you're responding verbally in an interview, then you're using the right side of the brain. But the things matched. The testimony was the same.

And then there were a lot of things circumstantially that matched, and the one that really kind of was very important for me was when **Corey** was talking about his trip to Mars in mid-2015 where he said that he went there with Gonzales to investigate slave labor abuses on Mars and described going to a colony where there was this kind of brutal manager of this facility, and he really ran it like a dictatorship.

Well, at the very same time that **Corey** came out with this information, the British Interplanetary Society organized this symposium in London where they had 30 top aerospace engineers and think tank people as well as some government representatives there discussing the very problem of how to remove a Mars' corporate dictator, that Mars would have a base in the future where there would be a dictator.

And it's like how do you remove this person?

Corey: Yeah, it was within days of the information coming out on "[Cosmic Disclosure](#)".

Michael: Exactly. Exactly. And then there was a lot of other kind of congruities in terms of President Obama signing a bill that would actually make space mining immune from any kind of regulatory oversight, which meant that any abuses that were happening in space in terms of corporations abusing slave labor that were doing space mining, that all of that was free from any kind of government regulatory frameworks up until 2022.

So this all began in that same time that **Corey** was coming out with this information.

So there were a number of other things like that.

David: One of the other noteworthy things I think about here is that you wrote the first book to actually discuss **Corey Goode**.

Michael: The book title is "Insiders Reveal Secret Space Programs & Extraterrestrial Alliances". And what I did in there was just used a lot of **Corey's** testimony that he had shared through these email interviews.

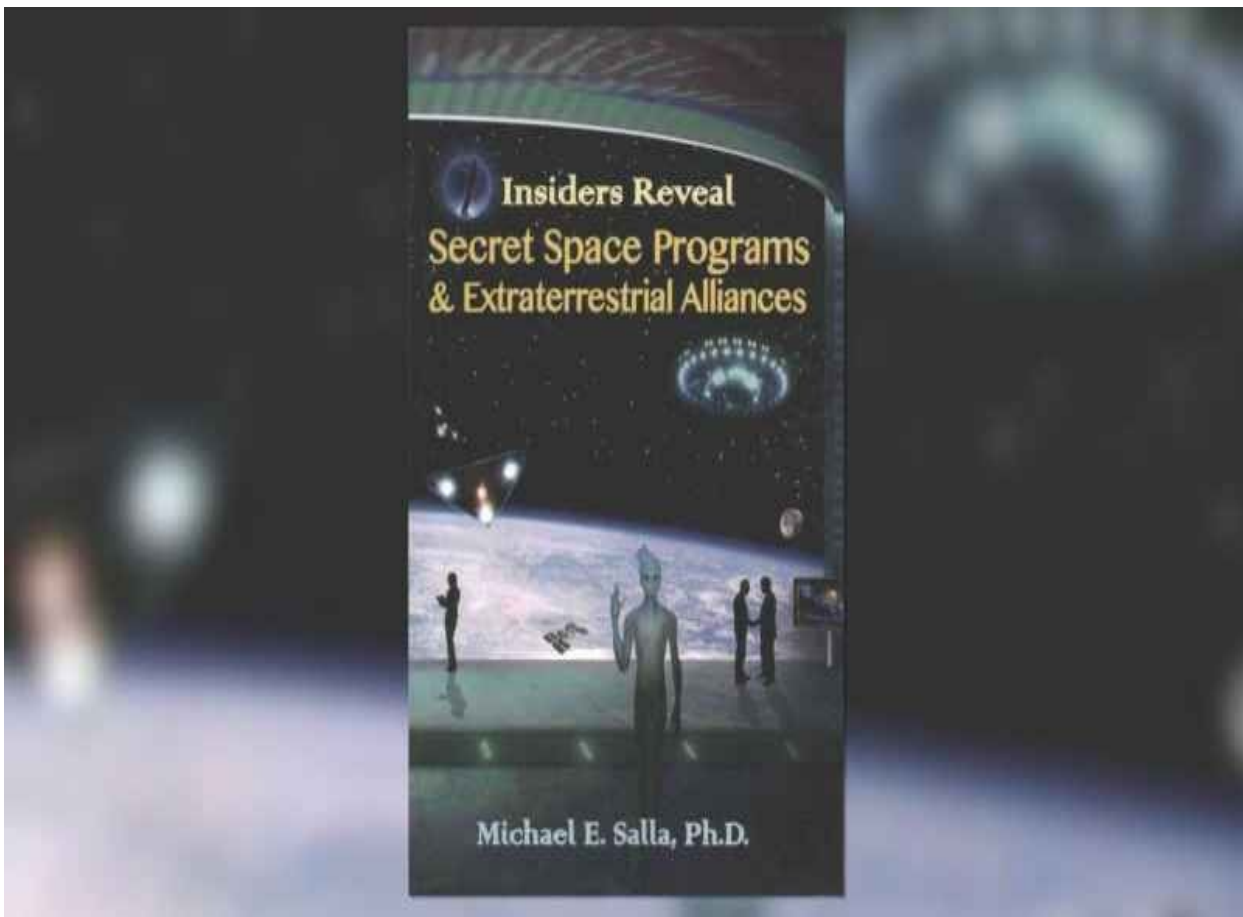

And so I used a lot of that material and just kind of did due diligence on it in the book in terms of – well, how does this match with historic documents? I mean, one of the key things that **Corey** said was that Nazi Germany had developed a secret space program and that this was operating out of Nazi Germany and out of Antarctica.

And so I looked into, well, what evidence is there that the Nazis actually did develop a space program? And so there were historic documents that kind of supported that.

One was a set of documents out of fascist Italy from 1933 that showed that Benito Mussolini set up a top secret think tank to study a retrieved flying saucer – that the Italians in 1933 had discovered a flying saucer and that they had set up a top secret group to study it under Guglielmo Marconi. He was the head of it.

And so that showed that Italy, as early as 1933, was studying this phenomenon. And then soon after Italy entered into the agreement with Germany, and they shared all of that technology, all of their findings.



So that kind of supported what **Corey** was saying.

Corey: And then you fast forward to **William Tompkins's** book coming out that is saying very much the same thing, and **Tompkins** had been writing it throughout the whole time we were doing this show.

Michael: Exactly. Actually, what happened was that **Bob Wood** got a copy of my book and shared it with Bill **Tompkins** . . .

Corey: That's right.

Michael: . . . and said, "This is very similar to what you're saying" because my book came out in September of 2015, and Bill Tompkin's book came out in December of 2015.

Corey: Yeah.

Michael: And so the book where I'm basically examining your testimony and the history of this Secret Space Program in terms of the role of Nazi Germany with two separate programs – one in Germany and one in Antarctica – that this was something that was in the book.

And Bill **Tompkins** reads it, and he's saying, "Oh, my God! How did this information come out? I thought I was the only one that knew about this, and I was going to break it."

Corey: Right.

Michael: But he was shocked that someone actually was sharing that before. So that was, to me, a very important corroboration from what you had said.

Corey: And I know you've done a lot of research into **Tompkins** since then. And through all the research that you've done, how many correlations have you seen? Has it been consistent?

Michael: Oh, a lot of correlations. I mean, just from very beginning in terms of how it all began, and then the role of the Navy, the US Navy, in putting together their own program to study what the Germans were doing, and then to begin the process of kind of reverse engineering and designing their own ships.

And so that was very important corroboration that **Tompkins** had to share.

Corey: Absolutely.

David: So, **Corey**, when he mentioned fascist Italy finding a UFO, I've never heard you on this show, or with any conversation, talk about what was the role of fascist Italy in this whole German Secret Space Program.

Do you have any personal knowledge of that?

Corey: Yes. Yes. A lot of the underground or mountainous types of bases that they had, they had in Italy.

David: Oh, really?

Corey: They were allowed areas in Italy where they could develop technology, and parts of it was developed in Italy.

Michael: And what I found very interesting that correlated between what **Corey** had to say and what Bill **Tompkins** had to say was that Marconi took a lot of that information to South America to start up a program down there – a kind of more private program – and Bill **Tompkins** said the same thing, that

Marconi did start up something down in South America and that the Italians actually had a very big space program.

And so that is also one of the things that I found correlating between Bill and **Corey**.

David: So **Michael**, did you get into the research of Die Glocke, the German Bell craft and the anti-gravity research that they were doing? Did you cover that in the book?

Michael: I did. That was kind of like the effort by the Nazis to weaponize these kind of technologies during the war.

David: Yeah.

Michael: So that was part of that kind of program that was run by the Nazi SS and under Kammler, and that's where you have witnesses who have talked about the Nazi Bell and how that was something that they unsuccessfully attempted to weaponize, but that in Antarctica, you had a lot of the top Nazi scientists going.

And that's where they really developed their most ambitious and, ultimately, the most effective space program.

Corey: Right. And the non-kinetic weapons to go along with them.

Michael: Right.

Corey: The energy-based weapons.

Michael: Exactly.

David: So did you ever get into Project Highjump, because that's one of the most remarkable things that **Corey's** testimony has shared with us is this idea of a planned invasion of Antarctica after World War II to try to defeat whatever Nazi base was down there?

Did that check out when you did the research?



Michael: Yeah, exactly. That was a very important part of **Corey's** testimony, and it's something I've been interested in for a few years. There's been a lot of rumors about Operation Highjump, and there's a lot of information out there about Operation Highjump in terms of exactly what it was that Admiral Byrd's taskforce encountered down there.

But what I found very helpful from Bill **Tompkins's** testimony was that he said that there was some context to Operation Highjump, that it wasn't just this battle where the Navy kind of tried to take out the Nazi base in '46, '47, that as a prelude that Admiral Byrd went down to Antarctica in '45, '46 to negotiate with the Nazis down there.

So there was an attempt to first negotiate with the Nazis, and that that negotiation was not successful, and that the British had sent their special operations teams down there in that summer of '45, '46, which is immediately after the Second World War, after Japan's surrender in August.

So that meant that after Japan's surrender in August, four months later, you have the British and the

Americans both sending groups down there to Antarctica to find the Germans, to find any bases, and to negotiate, because they had negotiated with the Nazi SS at the end of the war, so they thought they could do the same with the Nazis in Antarctica, but that failed.

And so according to Bill **Tompkins**, when Admiral Byrd went back to Washington D.C. and said, "Well, the negotiations have failed," that's when the Navy decided that, at the next opportunity, which would be the southern hemisphere's summer of 1946, '47, they would launch Taskforce 68, which was Operation Highjump.

And, of course, that gave the Germans time to finish the development of directed energy weapons so that they could outfit their flying saucers down there so that, when the Navy showed up, now they had these flying saucers that were very effective in fighting against the Navy's best fighter planes and took out their destroyers and other ships as well.

Corey: Did **Tompkins**, in that testimony, happen to mention high-level meetings between the US and the Nazi breakaway faction in Argentina, or did he mention Antarctica?

Michael: He said, in '45, '46, that Admiral Byrd went down to Antarctica for conducting those specific negotiations.

Corey: Because I did read about high-level meetings that occurred in Argentina.

Michael: Okay.

David: During the same time frame?

Corey: Right.

Michael: Right. Okay. Well, that would be very consistent, I think, because there were many kind of stories about Hitler and Kammler and Bormann all going down to South America, setting up what would be the kind of political power, or the political center, of the Fourth Reich.

Corey: And they're also the gatekeepers to what's going on in Antarctica.

Michael: Right. I think that's . . . Yes, so there would've been negotiations there or meetings there, but Byrd apparently just went down to Antarctica straight to conduct these negotiations, according to Bill **Tompkins**.

David: Now, you may remember – I'm sure you do – the insider that Rich Dolan interviewed who said that there was a plan at one point to invade Area 51 from the President of the United States.

So I think it might be good for you to share what you know about that with us right now as a context to Highjump.

Corey: I think a president actually made a threat to invade with the army – with the First Army Division or something.

Michael: Yes, that's right. That was a whistleblower that Linda Moulton Howe first interviewed about 12 years ago. He used the pseudonym Kewper, and he said that he was part of a CIA team that was commanded by President Eisenhower to go to Area 51, to the S4 facility, and to find out what was going on down there, because Eisenhower felt that he was out of the loop – that the agreements that had been reached with the Nazis, with extraterrestrials, Eisenhower assumed that as the President, as the Commander-in-Chief, that there would be a chain of command, because that's what he was used to.

David: Yeah.

Michael: But what became clear was that the people running things in Area 51, they had a different vision of how these projects would be run and that infuriated Eisenhower because he didn't have a problem with secrecy – keeping things secret – but he had a big problem with going outside of the chain of command.

So when he found out that the people running the projects out of S4 and Area 51, what he decided to do was that he said that he would basically use the First Army that was stationed in Denver, Colorado, to invade Area 51 if they didn't basically report – give him an adequate report, a full report – on what was happening down there.

So Kewper, this whistleblower, was part of that team that went down to the S4 facility. And he described what he saw at the facility, and he said that he saw nine craft. Out of those nine craft, he said four were from Nazi Germany.

Two of those four were the very first Vrill craft that had been developed by Maria Orsic and the Vrill Society, . . .

David: Wow!

Michael: . . . and the other two were Haunebu that had been developed by the Nazi SS for the weaponization program, and that the other five were extraterrestrial crafts.

So Kewper's testimony is important because it gives another independent source of evidence that there were these discoveries of Nazi programs involving flying saucers and that the American military had retrieved some of these.

He wanted to kind of clear his chest on this issue.

David: Yeah.

Michael: He really wanted to have a clear conscience that he had told the truth about some really important historical events that he was associated with, and he just didn't want to take that information to the grave.

So he's just one of many whistleblowers who have that conscience that this is information that the public needs to know, and they're willing to put themselves at great risk in sharing that.

David: So, **Corey**, we've got a situation here where you have Nazis in Antarctica. An invasion is attempted. It fails.

Then you have Eisenhower trying to invade Area 51. He fails. He warns about the military-industrial complex.

How do you . . . How does the Alliance see disclosure taking place? Because when people find out the kind of stuff, the exopolitic stuff, that Salla's talking about, they're going to be very upset.

There's totally non-governmental things going on for 70 years.

Corey: Right. Well, the Alliance perspective is let's just rip the Band-Aid off, start the healing.

What they're coming up against – this is the SSP Alliance – the Earth-based Alliance of all these various countries, some of them in the BRICS Alliance, have come together and started negotiating

with what we're calling "the Cabal".

And the Alliance, they have plenty to lose in these disclosures as well, but what they've decided to do is do a very protracted disclosure over decades. And that's just not good enough.

And what's really occurring within the Alliance – the SSP Alliance – is that they're trying to grease the wheels so that releasing information about Antarctica before the Cabal releases their sanitized version.

This is all an attempt to make this sanitized disclosure impossible.

David: Well, **Michael**, you said you wanted transparency, and some of transparency is going to include people getting really mad and becoming violent.

So how do you see this transparency as a key to solving our exopolitical issues?

Michael: Well, because with the transparency, then you can have accountability. You can have congressional inquiries. You can have inspector generals of various departments.

You can have senior military officers kind of finding out what their subordinates have been doing, because a lot of this has happened outside of the chain of command – that what happened to Eisenhower wasn't an isolated incident, that it goes on today.

So you actually have, for example, four-star admirals not knowing what a captain might be doing who's involved in one of these programs. Similarly for the Air Force and the Army.

So that's the key is with transparency then you have accountability. And I think that's the process, and that's really what I hope to be able to achieve in doing this research.

David: How do you feel the fear factor can be addressed? Like have you encountered a lot of fear from your audience as you disclose this and try to reach transparency?

That's what we're always warned about, right, is people are going to be so afraid that they can't handle the truth.

Michael: Well, the fear I've run into is more from the whistleblowers, the witnesses, that are fearful about sharing this. What is going to be happening to them?

I remember talking very vividly with **Clifford** Stone and giving him an interview, doing an interview with him, about 10 years ago. And he was telling me, "Look. After I finish talking to you, they're going to come in here and beat me up, but I don't care. I don't care. I can handle it."

Because he knew that this was what was going on, that that was the price for revealing the truth.

David: Wow!

Michael: As a researcher, or for in the part of the audience, I haven't felt that much fear in terms of revealing this. It's really the whistleblowers, the primary witnesses, that are really fearful for their safety and their families.

Corey: Yeah, I'd have to agree.

David: Do you think that this fear card is something that is being pulled as an excuse to maintain secrecy?

Corey: No.

David: Or do you think that people will actually be afraid when it comes out?

Corey: They genuinely believe that there will be a complete breakdown of society. They genuinely believe this. They've tested it. They've brought in scientists and soldiers, and unbeknownst to them, they expose them to an alien or to this information and then read their response.

After . . . You know, they have personality profiles on people that work for them, so they have different personality types.

They think this one will react that way if they have a Christian background, which many in the military did.

So, no, they genuinely believe that if there was a Full Disclosure, they believe that it's irresponsible to do because it will cause deaths, mayhem, rioting in the streets. And they're right. It will. That's part of

the process.

But if we keep kicking the can down the road, the reaction's just going to be worse.

David: If the beings that you're working with are benevolent, and they want Full Disclosure, what is their rationale for how we will respond as a people to Full Disclosure, and why they're pushing for it?

Corey: Basically, the most important thing to these higher-density beings is the development of consciousness.

Us not having transparency is holding back this consciousness renaissance that we're primed for.

So the minute we get this information, yes, it's going to be a bitter pill. But in the long run, it's going to have a bigger payoff for us in the development of our joint co-creative consciousness.

David: Well, it's a very good message, and I hope you've enjoyed this. I know I have. This is "[Cosmic Disclosure](#)". I'm [David Wilcock](#) here with our insider, **Corey Goode**, and our special guest, Dr.

Michael Salla of the Exopolitics Institute. We thank you for watching.

[Cosmic Disclosure: Disclosure and the Secret Underground War](#)

Season 7, Episode 10

David Wilcock: All right. Welcome back to "[Cosmic Disclosure](#)". I'm your host, [David Wilcock](#). I'm here with **Corey Goode**. And in this episode, we are going to get into the social and global implications of this virtually civilization-defining disclosure that apparently is coming our way after all this time.

It finally looks like we're going to get at least some of the truth, and the effect is almost unimaginable.

So, **Corey**, welcome back to the show.

Corey Goode: Thank you.

David: What the heck is going on with Senator John Kerry going to Antarctica on Election Day? What the heck was going on there? Why was he down there?

Corey: A lot of big names are going down there. Apparently, these people are being given tours of a city that was discovered under the ice a couple of miles, as well as technology, including spacecraft.

David: I heard from [Pete] Peterson independently that there are a bunch of names that have gone down there that are not public, and I'm wondering if you also heard that.

Corey: Yes.

David: So this is basically like the big tour that everybody's getting – everybody who's on a sufficient level of “need to know” or importance to this group is going down there.

Corey: Yes.

David: What kind of stuff is happening when they go down there? What are they seeing?

Corey: I don't know exactly what each individual is being shown, but I know that some of them have been shown these cities that they've excavated under the ice.

They've also been given a ride in spacecraft that have been recovered under the ice.

David: Actual recovered spacecraft?

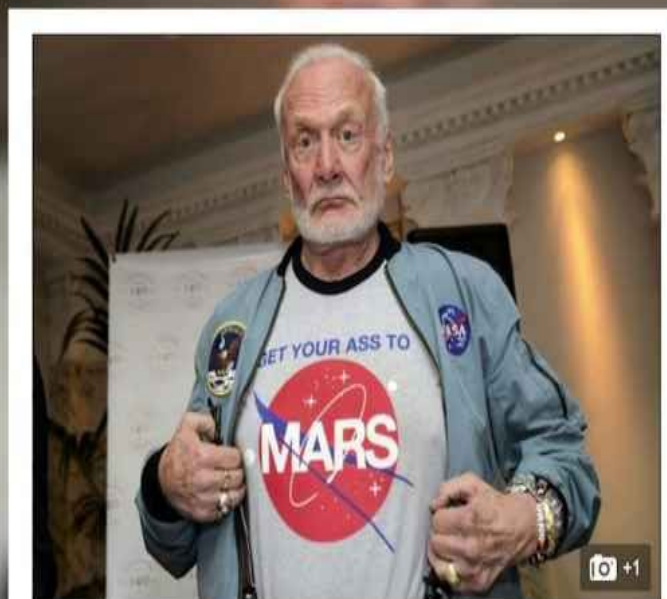

Former NASA astronaut Buzz Aldrin is recovering in New Zealand after experiencing health problems while on a trip to the South Pole ©FABRICE COFFRINI (AFP/File)

Corey: Right.

David: Well, that's very interesting because that ties in with something that I heard from **Pete** Peterson regarding Buzz Aldrin.

So why do you think he might wear that shirt, where it's describing traveling to Mars as an astronaut, while he's going down to Antarctica?

Corey: Well, maybe he's looking for a climate change on Mars. You now, that is a strange thing, especially now that we know that the ruins under the ice originate from beings that came from Mars.

David: And you said before that we can trace that all the way back. These people have a full unbroken historical lineage to Mars.

Corey: Right. They trace their lineage back extremely far and off of this planet.

David: So the interesting thing here is, based on what you just said, **Pete's** independent testimony to me when I called him and talked to him about what you were saying corroborated so many things, but then there was other stuff that you hadn't said.



And one of them was Buzz Aldrin reached a 200,000-mile altitude and said the impolite equivalent of “holy crap” seven times as he accelerated to that altitude because it was so fast.

Then he said that Buzz was taken around the back side of the Moon, got to see all of the Manhattan-type of lights that are there, all the structures, and then passed by a base that was over Antarctica as they came back in, and they gave it what he called a wing wave.

And that this apparently was what . . . The whole experience was so shocking to him that this is what caused him to have a heart attack.

I'm wondering if – since **Pete** said that so many of the assets of the space program that he's aware of are now over Antarctica – does this whole situation sound plausible to you that this could have happened?

Corey: It does sound plausible. I don't know the positions of the different MIC-SSP assets.

David: But this idea that the acceleration is so quick that somebody who is used to rocket-based travel might be really shocked. Does that make sense?

Corey: Oh, yes. And they most likely were on their lowest setting because normally it's so quick you don't . . . It's just kind of a blur.

David: So we're also hearing from **Pete** that there is a steam excavation method. You had mentioned steam excavation. But then **Pete** specifically said that they take large bags of water into these existing holes that are dug down in the ice. They drop the bag, and as the bag is about to hit where the ice is, they then hit it with these very high-powered microwave beams, and it all turns to steam and then, whoosh, it melts more of the ice.

Corey: That's how they open up a tunnel down . . . or open up a corridor down to an area. The rest, they do by hand with hoses with pressurized steam. They couldn't do that around the artifacts or it would destroy it.

A lot of what is being discovered under the ice are . . . They are finding palm trees still in the ground. They're finding all sorts of prehistoric animals under the ice still preserved.

David: Wow!

Corey: And they've been bringing those back to the United States and Europe for study.

David: So you also mentioned to me in briefings that you got that this is a disclosure that is planned for a specific purpose at a specific time.

And that's a very important subject. And I think it's going to become the meat of this episode.

So we've been talking about the idea that this is going to come out, but we haven't gotten really into why or when or what is the agenda. So could you give us the overview?

I know some of what you got were no-questions briefings and things like this. What is the overview of – why is all this being done, and how is it going to be used?

Corey: Well, the plan that the Cabal, and I guess the Earth Alliance, have agreed to is that they are going to release bits and pieces of the Antarctic information once there is a catalyzing event – that being they start arresting the Cabal or they start setting up tribunals.

David: 'They' meaning the Alliance?

Corey: The Alliance.

David: Because people might think it's extraterrestrials if they don't know any better.

Corey: No, the Alliance.

David: Okay.

Corey: But the Alliance is also kind of working with members of the Cabal. They're trying to come together to find a way to 'responsibly' disclose information.

David: So what we have is a situation in which the Alliance does want disclosure to occur, but they feel that if we were to get all of this at once, it would overwhelm us? And so they're picking something maybe more local, more associated with less of a leap in belief systems than UFOs and aliens?

Corey: Right. What they plan on disclosing first is that maybe, “We found a bunch of prehistoric animals. It's amazing.” Then, “Oh, we found remnants of a civilization,” and then only report that it was a human civilization that was very ancient.

That alone is going to blow the minds of most people.

They're going to unroll over decades . . . is what they plan.

Then they plan on announcing that we have a secret space program, and that, "By the way, the secret space program have found similar ruins around the Solar System."

Once that occurs, then they're going to start getting into the nonterrestrial aspect of the discoveries in Antarctica.

David: So only after they've done the SSP and other ruins like this in the solar system will they then talk about what you said they are calling the Nina, the Pinta and the Santa Maria – these three 30-mile-wide motherships they found under 3½ miles of ice?

Corey: Correct.

David: So that's pretty late in the game.

Corey: Yes. And the SSP Alliance does not want it to unfold this slowly. They want to rip the Band-Aid off and have a Full Disclosure immediately to everyone.

David: What do you personally think is the right move?

Corey: I think that we need to just get it over with and have a Full Disclosure. I understand that it's going to cost lives. It's going to cost people their sanity in some cases, but we've got to get on with it.

If you do it in a controlled way, the key word is 'control'. There's always a way for someone to come in and corrupt the process.

David: In order to keep going on this thread, I want to just really clarify something else, which is part of what you just described – the tribunals. We only really briefly touched on that, but I think that's really important.

Is there a plan for the Cabal to be brought up on public charges? And will there be some sort of remediation of our financial system and the damages they've done to us in that process?

Corey: What I was told is that they were going to attempt to do tribunals in secret, but that was not going to be allowed to happen. It would be leaked immediately.

David: So if it's going to be something that can't be done in secret, that's going to be leaked, what have you been told? Or what do you think this is going to end up turning into?

Are we going to see this on all the major cable news channels?

Corey: Yes. Yes.

David: There will be big broadcasts, which we did have with Nuremberg after World War II.

Corey: Right. They want it to be televised, even though very disturbing things are going to be covered.

But the plan is to do tribunals in secret, because the tribunals are not only going to be on the Cabal, they're going to be on certain members of the Earth Alliance as well.

David: So do you think that there are going to be some people who – perhaps major politicians – will be having public tribunals and others who are so deeply involved in the off-the-books side of this stuff that they will not be televised?

Corey: It just depends on how things break after the tribunals are leaked. It's going to be very dynamic.

David: Okay. Now, we're also dealing with crimes against humanity that are staggering in scope. And it seems rather hard to believe that we could have tribunals in which such staggering and multiplicitous crimes are being pinned on to multiple individuals.

It seems like even the minimum of due process that someone would be owed, in terms of the right to a fair trial, and then the number of people who might be implicated, that we could be looking at something that could take years to unfold.

Corey: Oh, yeah.

David: Do you have any sense of who they might try to do first in this kind of a process? Who would they go after first?

Would they go after major political figures, people that are the most recognizable, people who are the highest level criminals?

Corey: You can't go after a piece at a time. You have to decapitate them, and you have to bring them all shoulder to shoulder in front of the magistrate at once. You can't do it in bits and pieces, or it'll just fall apart.

David: Do you think that there might be some sort of mass arrest that precedes this in which all of the people who will be on trial are then brought into some sort of holding facility where they're kept under guard and could not easily escape, if at all?

Corey: It's possible. A good number of them are already under house arrest.

David: But what does house arrest mean for those who don't already know that term?

Corey: They get to sit in their mansions, sipping tea, with armed guards outside not allowing them to leave.

David: Now, you've also said before that there's been a lot of these Cabal folks that if they feel the heat is on, they're going to try to flee to maybe Argentina, South America or Antarctica, and that there may be a sudden number of people who all want to resign at the same time or something like that.

Will they be able to evade justice?

Corey: I've received reports of bases that were controlled by FEMA . . . that they were supposed to turn the bases over after this election. They were ordered to turn them over, and they refused.

So they sent in Marines. The Marines cut through the concrete, the rebar, the reinforced steel, and gave everyone in the complex one chance to surrender.

If they don't, they're ordered to wipe them out. I heard this from one source, and another source told me that it wasn't true, but it seems that you've independently . . .

David: [**Pete**] Peterson confirmed the same thing. And it was another one of these very shocking correspondences that led me to understand that the MIC-SSP we've been talking about – the Military-Industrial Complex Secret Space Program – is actually working with **Pete** and with you at the same time.

Corey: Right.

David: There were way too many things that **Pete** knew that you told me off the record.

Corey: The Marines that breached this one base I was told about and were in the middle of wiping out all of the inhabitants, they were shocked. They were not briefed that nonterrestrials exist or that they may run into them.

And these were like Special Forces Marines guys. All of a sudden they're in front of Reptilians, and they're doing battle with Reptilians.

And their psyches couldn't handle it. They had a huge problem.

David: This is also something that was exactly confirmed by **Pete**. And about the only difference is that you just mentioned Marines, and he said that some of the people that were used were Canadian Marines as well – Marines who were trained and based in Canada that were then tasked with this.

So we're talking about something that we've thought was going on for a long time. We see these strange earthquakes underneath Italy, strange earthquakes off the coast of Argentina, strange earthquakes off the coast of Malibu right actually directly around where people think there is a base off the coast of California.

So are these strange earthquakes, like in Italy, in South America, and so forth, all a part of this massive purging of underground bases?

In other words, what's the scope of this that's being done?

Corey: There has been quite an underground battle going on. Both sides are fighting as hard as they can right now.

David: It kind of shocks me to have heard from **Pete** that he got a call about how to dispose of 15,000 bodies, and they didn't really know how to do it.

It kind of shocks me that actions are being taken where the Cabal is either being given the choice to surrender, they have one chance, or everyone in the base is eradicated.

It's going to lead to people in the Comments Section saying, "If this is the Alliance, then what the heck is the Alliance?"

I will just tell you – before you answer the question – that as I've wrestled with this in my own mind and heart over the course of days – because I don't want to support killing innocent people at all – the only rationale that I can come up with maybe for why the Alliance is doing this is that they feel as if this is an absolutely necessary thing to save the planet from total destruction, and that therefore these are casualties that are necessary in a very serious World War III that's just a shadow World War III that we're not aware of.

Corey: Well, if people out there are under the impression that angelic humans are going to come down and save us, they're wrong. These are very damaged human beings that are a part of the Alliance.

Most of the time they were forced to work for the Cabal, and they resent it. They know that the Cabal would give them zero quarter if the tables were turned.

David: Right.

Corey: They're not giving them quarter as well.

David: So would you say that there is some kind of decision that has been made that these people are so dangerous if they're not neutralized that they would try to, for example, nuke the planet or give everyone a virus or give everyone a catastrophe, like a volcano or a tidal wave or something like this?

Would they try to destroy all human life if they weren't wiped out like this?

Corey: Well, these are military-minded people, and the point is to complete an objective with as few casualties as possible. So that is the way they head in to all of these situations.

They are not going in looking to take prisoners or to ferret out who is innocent or not innocent in a base.

They're ordered to go in and clean out the nest, and that's what they do.

David: So let's also just briefly touch on this idea that you can confirm that this is a multi-year operation that just happens to be coming to a head around the time of a presidential election, but it is not determined by the outcome of the election itself. It was already underway. It just happens to have converged.

Corey: Right. No matter who would have won the presidency, there would have been . . . things were already occurring underground.

David: And it would have led to tribunals on the surface.

Corey: Right.

David: Which gets into things that we saw in WikiLeaks and all this kind of stuff, all paving the way for that.

Corey: Correct.

David: Another one of the things that you said to me, or kind of said to me, that also was in Benjamin Fulford's intel that I then got even more specifics from with **Pete** Peterson, was this idea of all of the – or at least the great majority – of the aircraft carriers from the US defense community have been brought back to port.

So I want to hear what you had to say on that, and then we'll compare what **Pete** told me and try to make some sense out of what's going on here.

Why would all of the aircraft carriers have been brought back to port? Fulford reported this. I asked **Pete**, and he confirmed it.

Corey: Well, there's a number of reasons. You're going to bring back all of your craft when there's going to be a reshuffling of the DOD [Department of Defense].

David: Right.

Corey: So there are things going on in multiple levels.

David: So you're going to have different people in command?

Corey: Right.

David: Okay.

Corey: So there are probably captains being swapped out, all kinds of stuff. I haven't heard a whole lot of details about why they were back, except that they were back.

David: What **Pete** said to me was that these ships take six months of people working 24 hours a day, seven days a week, to be restocked.

And he said that they were being restocked with technology that we were not “supposed to” find out about for 100 years.

You had mentioned drones, and you had mentioned that there are certain drones that we might see.

So before I say what **Pete** said, could you talk to us about the information you were given in these briefings regarding drone aircraft?



Corey: Sure. That we are going to start seeing more and more quadcopter-type vehicles around. They look like passenger cars with four propellers on them – four sets of propellers – that give them lift.

And they use a type of artificial intelligence – believe it or not – in the craft to allow it to have

automatic air traffic control, landing. The people don't fly them.

They get in, put in a destination, and it will fly itself.

And what I was told was that this technology would be very prolific. You will see it everywhere. They will be flying all over the place.

And they were planning on a number of years after this was commonplace – this technology was commonplace – they were going to replace the rotors on the drones with this technology that is antigravity.

And what I was told is that the antigravity craft fly in much the same way as drones with yaw, pitch. They're controlled in very similar ways.

David: Isn't it interesting that the sequel to the movie “Independence Day” has what looks sort of like conventional military aircraft, but with these disc-like gravity generators on them?



Corey: Uh-hm.

David: Do you think that is a premonition of what this is actually going to look like once they do it?

Corey: Yep. They're going to be flat, disc-shaped.

David: Okay. Interesting.

So **Pete** had said that we're going to see some of the same military hardware that we're already familiar with in there, but that there's so much of a redesign with all this new stuff that they weren't going to show us for 100 years. It's all being put in.

It's not like we might see it all immediately after they go back out from port, but the point is they're now going to be on the ships and that it includes these three different sizes of drones that we see in these Hollywood films.

So what do you think is going to be the purpose of having three different sizes? I'm wondering if you actually heard about the three sizes?

Corey: Well, they've got all different types of these – what we're calling drones. And they have different purposes like you have different sized aircraft for different purposes – delivering weapons, delivering personnel. Some of them are very large and deliver large numbers of personnel.

What I've also been told is that they're retrofitting certain types of helicopters, certain types of aircraft, with this technology that we're talking about, and that we're going to be seeing a lot of retrofitted already conventional craft that we're used to.

David: I want to say this because people are going to say in the comments – and I want to give voice to that because it will obviously happen; we can anticipate this – you look at movies like “The Terminator”. You look at movies like “Oblivion” with Tom Cruise and Morgan Freeman, in which drone aircraft are under control of malevolent AI, and the drones become a critical element of humanity being completely subjugated by nasty AI.

You've mentioned an AI problem. If these are computer-controlled drones, how do we stop this AI menace from actually taking control of all of these drones if they are deployed and trying to subjugate humanity?

Corey: I don't know the answer to that. That's a danger. It's a current danger.

I still get screened for AI when I go certain places. So it is still a concern.

David: So there's a couple of things that happened around the time of the presidential inauguration that were very anomalous, and they both happened almost simultaneously.

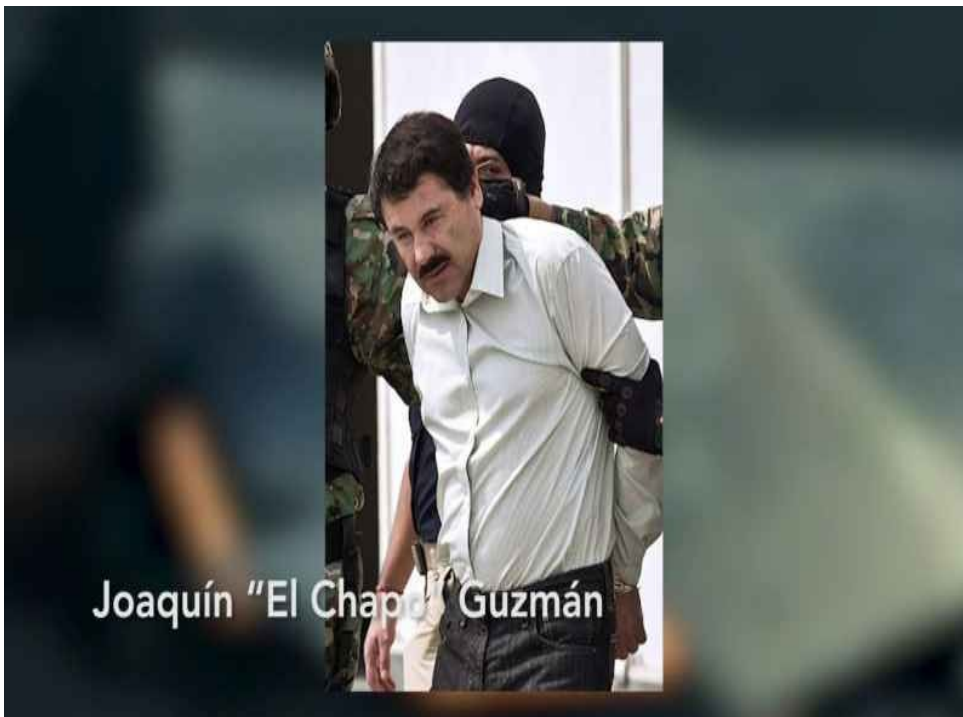

One was that we have the Mexican drug lord of the Sinaloa Cartel – this guy who they call El Chapo – actually being extradited to the U.S.

So let's talk about that one first. And the reason why I bring it up is that multiple Benjamin Fulford updates said that if he could be brought to the U.S., which the Cabal was staunchly resisting, that he would sing like a songbird.

So what do you think is the reason why El Chapo was brought to the U.S. at that time?

Corey: I believe he's here to talk about all of the intelligence operations that involve the drug trade and name names.

David: And I want to point out in one of the episodes of my show "Wisdom Teachings", we have a news story of guys being caught smuggling cocaine into the U.S. with the Sinaloa scorpion logo on

them. And it was a massive amount.

And then when they were asked to produce ID, they had CIA identification. And they were caught by this group of 1,500 minutemen who are working . . . they're like former military, but they're not really part of a regular government operation.

So what do you think is the relationship between that story and this El Chapo story?

Corey: I believe that they're ramping up for tribunals. I believe that – as I've reported – they've had Cabal people that have turned state's evidence, that have been singing like birds for a long time.

They've been sitting them in front of cameras, asking them all the questions, and they've been spitting out ALL the deep dark secrets.

David: Another thing that happened right before the inauguration is that both George Bush, Sr. and his wife, become hospitalized in critical condition with what appears to have been either heart attacks or stroke-type of stuff, which, of course, would be due to high stress.

Corey: I think the election was more than most of us could bear.

David: Ha, ha. Do you think that they are fearing some sort of tribunal, and that once they saw this result that that caused their health to collapse?

Corey: All of these people are in great disarray and have a lot of anxiety right now – the people that were involved in these Cabal operations.

There is a lot of movement going on in the background to close bases, to clean up their active operations – the active operations of the Cabal.

So they see all of their assets disappearing around them, and that's what made them feel so secure in the past.

David: As you were giving me these stunning briefings, and as I was getting confirmation independently from **Pete**, I was living through what's now being called the biggest amount of rainfall and flooding to hit California since 1986.

We go from no rain at all – hardly – for six years, absolutely devastating drought that they say is never going to go away, and at the time of this taping already, the drought has been completely eliminated in Northern California. It's gone. It's totally over.

And they were saying, “Well, there's still kind of an extreme condition in Southern California,” but then more storms are coming in that have totally saturated Southern California. So we're probably going to see Southern California drought-free as well.

And there's so much water that they're calling it “an atmospheric river”. So what do you think is going on here?

Corey: The information I was given is that while the Alliance has been going and taking over a lot of these bases, they have taken over these HAARP facilities [High Frequency Active Auroral Research Program].

And what I was told was that when they shut off all of the HAARP facilities, there was an elastic snapback reaction of the atmosphere.

David: That would dovetail very interestingly with this weird arctic vortex that popped over the entire North America.

Corey: Right.

David: So do you think that's part of what they're talking about – the snapback?

Corey: Yes.

David: Okay.

Corey: Yeah, that it's the Earth naturally snapping back after the weather patterns had been augmented for so long.

David: Now, that's similar to what **Pete** said except that his intel was that the actual HAARP is being used benevolently now to directly steer this atmospheric river to California.

What would be the reason for why the Cabal might have been trying to eliminate water to California?

People think, “Oh, those hippies just don't get to flush the toilet as much.” But there's something going on here. What do you think was the objective for this drought?

Corey: The Cabal had been using HAARP and other technologies to control weather all over the planet. And when they control the weather or cause droughts or cause deluges, they are also, at the same time, sending their people in to talk to the people that control politically that region and have them manage policy based on getting the weather that they want to be able to grow crops.

David: So do you think that California being thrown into a drought is an attack against all of America and its food security?

Corey: Yes. Yeah, that's the breadbasket.

David: Right. So this is not just something about people not being able to water their lawns in California, it's an attack against America itself.

Corey: Right.

David: To me, this rain – because I live in Los Angeles – I have been saying for years, we will know when the Cabal is defeated when it starts pouring rain for days and days at a time.

And right in my little hometown, we've had so much rain that Topanga Canyon Boulevard has been shut down for like a week.

Corey: Yeah, I saw a giant boulder blocking the road.

David: That's right.

Corey: Yeah.

David: So the last thing that was in these briefings that I want to get to before we run out of time here, is you mentioned two other things that were very interesting that might come out along with Antarctica.

You mentioned rooms filled with gold, and you mentioned other ruins that might be seen on the seafloor.

Corey: Some unusual intel that was given to me, and it was somewhat out of place in the rest of the briefing, was that there was going to be a “discovery” of caches of ancient Mayan gold.

David: Wow!

Corey: And that this was going to be discovered and given back to the indigenous people.

David: Really?

Corey: Yeah.

David: And it was fascinating on that front, because I brought this up to **Pete** that you had mentioned that to me, and then he had a huge story about rooms filled with gold that were actually found by Bush, Sr., and, in that case, plundered. And so there's a lot of corroboration.

Hopefully, we can get him back to talk more about that.

The other thing you'd mentioned was undersea anomalies or bases or ancient ruins of some kind that would be announced maybe at the same time as Antarctica. Could you say more about that?

Corey: Or maybe just before.

David: Oh, just before?

Corey: The various navies of different countries for many decades have been discovering all types of ruins at a certain level below the ocean, . . .

David: Okay.

Corey: . . . certain depth, that depth and above. [**Corey** separates his hands about one foot.] And they have been doing sonar sweeps of them, getting all types of information, sending vessels down there that can properly excavate. And they've been bringing out artifacts.

And this is . . . I'm told that this is also going to be a part of some announcement about a lost civilization.

David: So one last thing I want to close with here is, do you think that the Cabal had originally intended this Antarctic disclosure to be some sort of massive distraction, maybe more benevolent, but

on the level of like a 9/11 level of distraction to throw people off if these war crimes tribunals were to ever begin?

Corey: No. Originally, they had planned to slowly release this information so that we would see these royal bloodlines the way they do and treat them like gods.

David: Wow! But now you're saying the Alliance wants to use this as part of the beginning of the healing of how long people have been lied to as the Cabal is brought to justice.

Corey: Right, right. And the Cabal still wants to manage the release of the information, as do many of the Alliance.

David: So do you think that it's possible that some of the things that we've said, or the order in which it's done, could be changed around by the fact that we've already disclosed it now?

Corey: Yes. This is all very dynamic. Decisions are being made. They're having all types of meetings to come to a consensus between the Cabal and the Alliance.

And they're doing this to prevent open warfare. If they don't come to a consensus and find a way to work together to disclose this information and to bring the worst of the worst to trial, then we'll end up with a world war.

David: And can you confirm, lastly, what **Pete** has also said, which is that certain websites, like www.express.co.uk – new story, new story, ruins in Antarctica, lost civilization in Antarctica, professors down in Antarctica, Buzz Aldrin goes to Antarctica.

All of a sudden, it's like there's some crazy amount of correlation between what little old you and me said and all of this stuff coming out in the media. What do you think is going on there?

Corey: They're trying to pepper the consciousness with seeds of information so they're not so shocked when they hear it.

And they're also trying to control the narrative.

David: All right. Well, you heard it here first. I really hope that this stuff comes true. Thank you, **Corey**. It's very brave for you to be stepping out there and giving us this information. The war is getting hot.

Corey: Yeah.

David: It's very contentious right now.

And I want to thank you out there for watching us, supporting us here at Gaia, and making sure that we are on a path towards Full Disclosure. Thanks for watching.

Cosmic Disclosure: Tracing the Roots of the SSP with Michael Salla

Season 7, Episode 11

David Wilcock: All right, welcome to “[Cosmic Disclosure](#)”. I'm your host, **David Wilcock**. I'm here with **Corey Goode** and our special guest Dr. **Michael Salla** from Exopolitics Institute.

So **Michael**, welcome to the show.

Dr. **Michael Salla**: Thanks for having me on the show, **David**.

David: Thanks. And **Corey**, good to have you back, buddy.

Corey Goode: Thank you.

David: I was talking with you about another book that you wrote, “Kennedy's Last Stand”, and so I'd like to open with that for this episode.

Michael: Well, the book really goes into what Kennedy knew about this whole topic. And the thing that
...

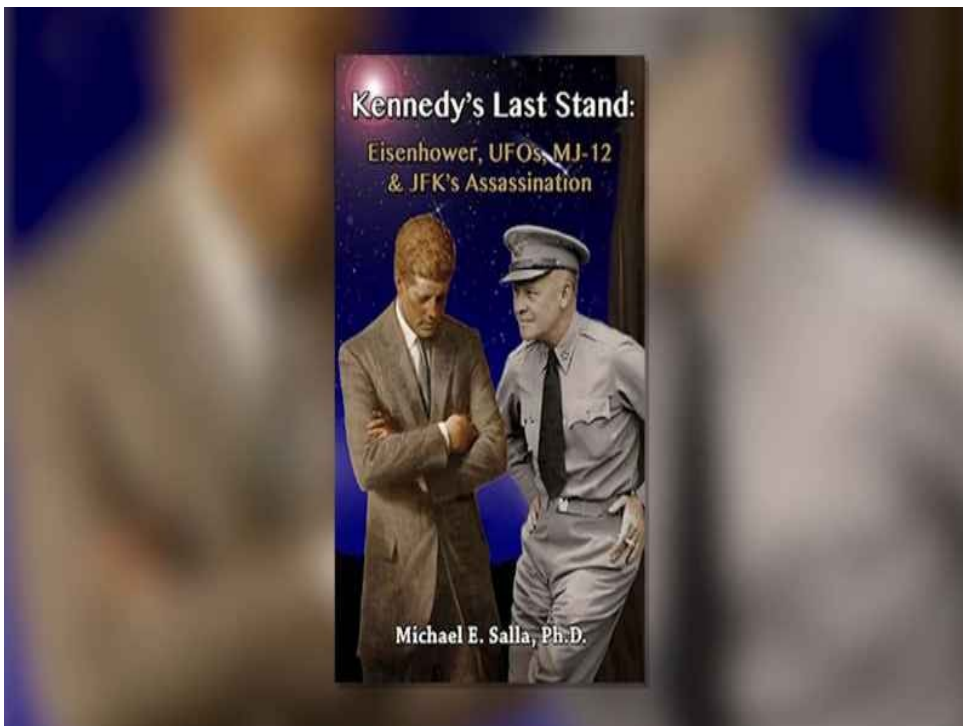

David: What whole topic?

Michael: The topic of UFOs, flying saucers.

David: Oh.

Michael: Kennedy was very interested in that, and so the book looks at his history of trying to find out about it. But one of the things that I did in that book was, I was able to find out that, early in his career, Kennedy was actually a protege of James Forrestal, who at the time was the Secretary of the Navy.

Corey: The Navy, yeah.

Michael: And so Forrestal took Kennedy . . . This was before Kennedy became a congressman or even entered politics. And Forrestal, at the time, wanted to recruit Kennedy to his personal staff.

So Forrestal took Kennedy on a fact-finding trip to Germany in July and August of 1945. So this is after the war.

You had the Navy there, the Army there, basically pouring over everything that the Nazis were developing in terms of secret technologies and trying to find out what it was that they were going to bring back under Operation Paperclip – scientists and technologies.

So Forrestal . . .

David: So even though they fled to Antarctica, it wasn't like they got everything out.

Michael: Exactly, yeah. The Germans still had a lot of really advanced stuff down there. Certainly, as far as the Air Force and the Navy were concerned, the stuff that the Germans were working on in occupied Europe was just way ahead of anything they had.

So the Navy was there trying to work out what it was that they should ship back to the U.S. to work on in their top secret laboratories.

David: Let me ask you this. Did the U.S. have captured German soldiers and scientists who were telling them what was there? Or were they just going into an abandoned building and then trying to poke around and look for things?

Michael: Oh, they had both. They had a lot of scientists, engineers, that were trying to cut a deal, trying to get a favorable place to live, or maybe even get repatriated to whatever country they were originally from, or even to the U.S., . . .

David: Right.

Michael: . . . people that had documents that wanted to cut a deal. People knew where the secret laboratories were.

So you had all of this happening, and so the Navy and the Army had their top intelligence teams in there trying to sift out exactly what was available.

David: All right. Sorry to interrupt, but I think this is really important, too.

In case people are younger, they don't understand this, Kennedy is not just an ordinary family. We have a background on the Kennedys in which Joseph Kennedy, the father of all the Kennedy brothers, was well-known as a bootlegger, and had made a significant fortune.

Michael: Well, yeah. He was a very successful businessman. I mean, he did a number of things, and bootlegging during prohibition was one of the things.

David: Right.

Michael: But he's probably best known for being the ambassador for the U.S. to England just before the Second World War.

David: Okay.

Michael: And he was also, along with James Forrestal, the . . . he became the first, I think, it's the President of the Securities and Exchange Commission.

David: Oh, really?

Michael: So this was . . . So he was really at the apex of the financial system in the U.S. at the time.

David: Right, because the SEC is what's regulating the whole stocks and commodities markets, and all that.

Corey: Yeah. And the tie-in to Forrestal is obvious. Forrestal pops up in ufology everywhere.

David: MJ-12, right?

Michael: Right, yeah. He was on the MJ-12 committee. And Forrestal, he was the guy that worked for a major financial company Dillon and Read. And so he was picked by the Navy, by Roosevelt, to actually help the Navy prepare for the war, because he had the expertise, the knowledge of major scale industrial manufacturing, and the Navy needed to really change in order to deal with the pressure of fighting two wars.

Corey: There are some interesting tie-ins between Forrestal and **William Tompkins**, are there not?

Michael: Very important. According to **William Tompkins**, Forrestal was the guy that picked the admiral that would run the top secret Navy program that was going to be trying to get as much information as they could on what the Nazis were doing, in terms of secret space technologies.

And Forrestal was also the guy that somehow was influenced by Nordics to pick Rico Botta to actually play this role.

So Forrestal was in communication with these Nordic extraterrestrials. And that's a part of what I discuss in the new book, "The U.S. Navy's Secret Space Program", the way in which Nordics

extraterrestrials were helping the U.S. Navy, right across the spectrum in terms of – from the very beginning to the very end – in the Navy's developing a secret space program.

David: Do you think that at the time that Forrestal is bringing Kennedy over to this very recently defeated Germany, to get into all the good stuff, do you think they already had a plan with Joe Kennedy that his sons were going to run for president?

Michael: Well, that may have been a factor in why John F. Kennedy didn't accept Forrestal's offer . . .

David: Oh, he didn't?

Michael: . . . to join his personal staff, because Forrestal wanted to recruit Kennedy to his personal staff, and because Jack Kennedy died and – you know, his brother, his older brother died – the father, Joe Kennedy, wanted John F. Kennedy to now enter politics.

David: Oh.

Michael: And so that was why Kennedy turned down Forrestal's offer to be a part of his personal staff, and Kennedy then entered politics instead and became a congressman – elected to Congress in 1946.

David: Well, do you see, in your research in “Kennedy's Last Stand”, any other evidence that Kennedy was actually given briefings or was made aware of some of what was going on with the extraterrestrial question?

Michael: Well, not so much as far as the extraterrestrial question is concerned, but as far as Nazi Germany's advanced programs, he was given access to all of it. I mean, he knew what . . .

David: Really?

Michael: . . . was going on, that Forrestal actually was showing Kennedy all of these advanced technologies and Kennedy wrote about it in a book that was published posthumously, called “Prelude to Leadership”.

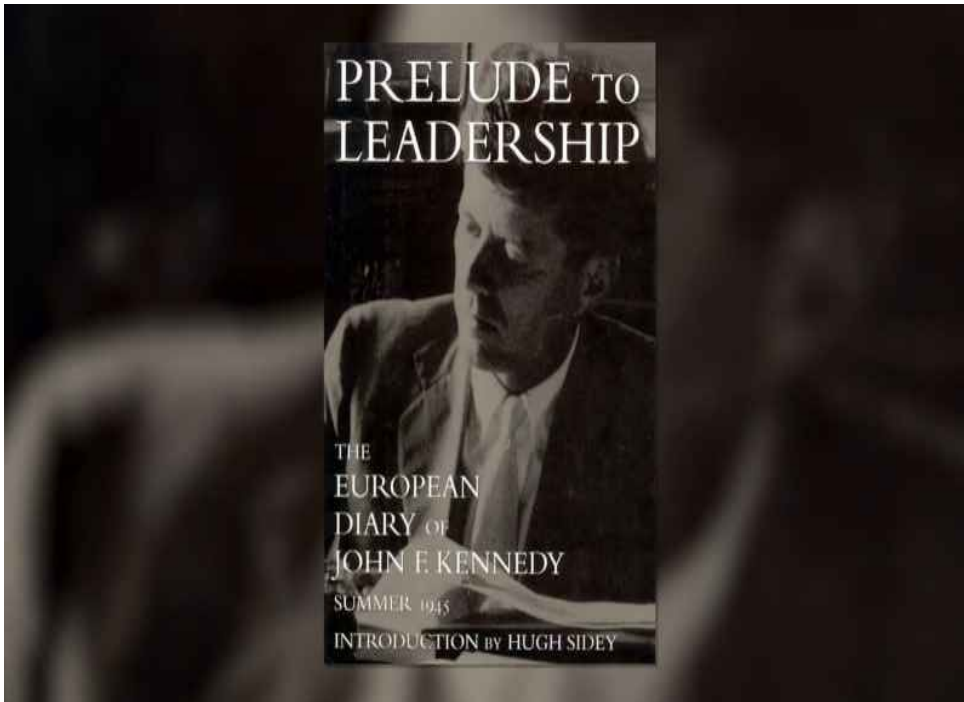

Not many people know about this book . . .

David: Never head of it.

Michael: . . . but it's a book, written by John F. Kennedy, about his time in occupied Europe, and in Germany, in particular. But the important thing to keep in mind here is that at that same time as Forrestal was showing Kennedy all of these captured German technologies, that Forrestal was the guy that was ultimately in charge of the Navy's secret espionage program in Nazi Germany, where they were getting all of this intel about Germany having two secret space programs.

And so Forrestal was looking, on behalf of the Navy, for anything that he could find about Germany's secret space programs.

And so that meant that Kennedy knew about all of this, as well.

David: Right.

Michael: And so this is an important historical fact that that book really articulates, that because of Kennedy's exposure to this whole phenomenon of advanced UFOs, flying saucers, extraterrestrial life – the kind of information Forrestal was sharing with him - because of that, when Kennedy became president in January 1961, that Kennedy really made an effort to get to the bottom of this whole

phenomenon and really get power back, in terms of the president running these secret projects, rather than the projects becoming autonomous, as happened under Eisenhower.

David: All right. I want to ask you one more question about Eisenhower, and then I want to toss it back to **Corey** for a clarification.

We know that Eisenhower ordered this invasion of Area 51, as we talked about in our last episode. And in his infamous closing remarks as he leaves office, he warns about the acquisition of unwarranted influence, either sought or unsought, by the military-industrial complex, and then he hands it over to Kennedy.



We must guard against the acquisition of
unwarranted influence, whether sought or
unsought, by the military-industrial complex.

(Dwight D. Eisenhower)

Have you researched whether there was a conversation between Eisenhower and Kennedy about what Eisenhower had experienced in that transition of power?

Michael: Well, we know from official records that Kennedy met with President Eisenhower twice while Kennedy was President-elect, that they met in December and in January.

And the January event was just a couple of days, two or three days, before the farewell address. So I think it's fair to assume that whatever Eisenhower shared publicly is much, much less than what he shared privately with Kennedy.

David: Now, you've undoubtedly done research on this idea that some kind of benevolent extraterrestrial group met with Eisenhower.

So for those who are not familiar with that, could you just talk a little bit about your knowledge of the Ike and ETs event?

Michael: Sure. Well, I think that there's so many different whistleblowers who've come forward and witnesses, that we can kind of get an idea of the chronology of these different meetings that Eisenhower was a part of.

That starting in February of 1954, that Eisenhower traveled to Edwards Air Force Base, and he met with a positive group of extraterrestrials – what Bill **Tompkins** describes as Nordic extraterrestrials – and they kind of really emphasized to him the dangers of developing nuclear weapons – thermal nuclear weapons at that time were being deployed; these were hydrogen bombs – and that the Eisenhower administration should follow a more peaceful policy and be open to receiving more spiritual, more ethical information.

Eisenhower, I think, personally, was very impressed by the Nordics, but his national security team said, “No, we're not going to give up nuclear weapons, and we're not going to listen to this kind of spiritual, ethical upliftment talk at all.”

So then Eisenhower met with another group of extraterrestrials in February of 1955, this time at Holloman Air Force Base, and this was a group of Grey extraterrestrials, tall Greys, that basically reached agreements with Eisenhower in terms of sharing their technologies.

The Greys weren't too perturbed that the U.S. was developing thermal nuclear weapons, and so that's where the agreements began with the Greys.

David: The alleged Tau IX Treaty that led to the formalizing of abductions and all that.

Michael: Right, exactly. And this, of course, all happened after the flyovers in 1952, the Washington flyovers, where you had those craft flying over.



And, of course, the big debate is, were they extraterrestrial or were they Nazi? And, of course, we've had different stories on that, but what Bill **Tompkins** and what **Corey** have said, as well as Clark McClelland, is that these were Nazi craft.

And so that suggests that the subsequent meetings that happened, these were . . . The agreement that happened after the Holloman Air Force Base was with a group that was allied with the Nazis.

And interestingly, one of the witnesses that was at Holloman Air Force Base in 1955, he actually referred to that Nazi element.

David: All right. So **Corey**, what was your personal knowledge of extraterrestrial contacts with presidents? When did that first start? Did anything happen with Truman? Did anything happen with Eisenhower, in terms of what you were told, yourself, on the inside?

Corey: There were meetings with Truman and Eisenhower. Eisenhower was meeting with groups that he mentioned, non-terrestrial groups, as well as one called the Blues.

He had a number of meetings where Nazis flew in in these flying saucers, landed it on bases, and came out and had meetings with, I mean, actual Nazis, as well.

David: And we've briefly touched on the Blues before, but this is a fascinating area for me because I was able to independently confirm what you said with **Pete** Peterson.

So could you describe for us, why were they called the Blues? What did they say and how was it taken?

Corey: They were called the Blues because they had blue skin, and their agenda was peaceful.

Much like the Nordics, they were advising us not to dabble in nuclear energy or weaponry. They also were giving us spiritually uplifting information, information about consciousness, stuff that the military really had no use for.

And much later on, they were referred to, and the Nordics, they refer to them, jokingly, as 'space hippies'. Although there were no hippies in the 1940s, later on they were called that.

David: What was the deal that the Blues were offering? What would we have to do to get their cooperation?

Corey: Give up nuclear weapons. Give up the pursuit of nuclear weapons.

David: But what would be the payoff for us if we did? What were they offering as the carrot?

Corey: To begin to help us spiritually, to integrate with other civilizations.

David: Now, you had mentioned very briefly Clark McClelland, and that's just popped up on the radar screen recently in a new insider correlation with **Tompkins**.

And I'm sure you're familiar with that, so could you share with us how McClelland has suddenly popped into the story?

Michael: Well, with Clark McClelland, he was a spacecraft operator for NASA at the end of his career. Prior to that, he worked for about three decades for various NASA contractors.

So he had a bird's-eye view of what was happening at NASA, and so he was able to confirm what Bill **Tompkins** had to say, that NASA had been infiltrated by Nazis.



Clark McClelland, for example, said that when he went to the office of Kurt Debus, who was the first Director of the Kennedy Space Center, that McClelland met Hans Kammler.

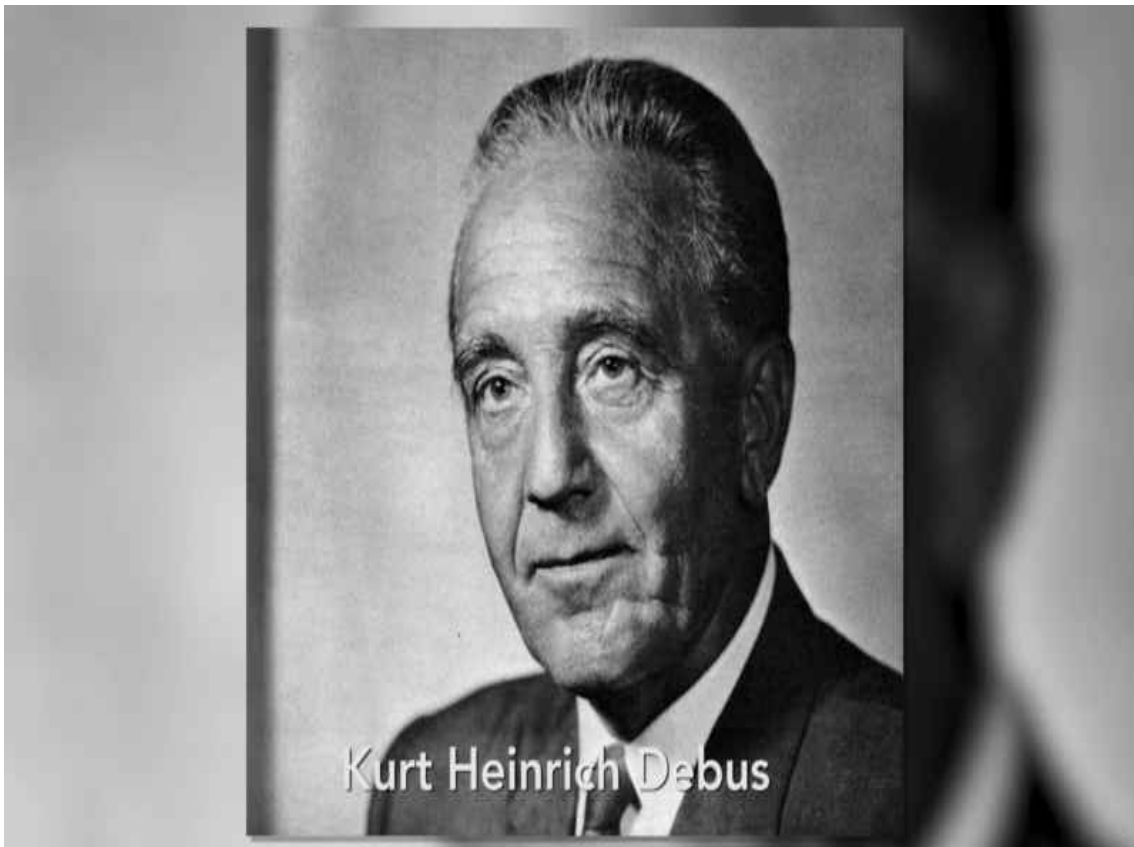



And Kammler was the Nazi SS General that ran their Secret Space Program in occupied Europe, trying to weaponize the technologies – the Die Glocke or the Nazi Bell – that Kammler was in charge of all of this.

So here you have Kammler, in the 1960s, at the Kennedy Space Center meeting with the director.

And so McClelland was able to confirm that that was actually happening, and so that was confirmation, or really strong corroboration, for what Bill **Tompkins** was saying about the way in which the Nazis continued to have this undue influence over the entire NASA space program, and had actually infiltrated the military-industrial complex.

And that's one of the things that **Tompkins** says, that the military-industrial complex – various companies and various military organizations – found themselves almost in a kind of proxy war between these different extraterrestrial factions: the Nazi Reptilian group that were trying to infiltrate and take over the U.S. military-industrial complex, and then another group, the Nordic extraterrestrials, who identified the Navy as really being the one U.S. institution that was kind of much more aligned, or supportive, of U.S. constitutional values.

David: For those who are watching this show who are not familiar with Clark McClelland, I know what his background is, but I'd like for you to share in your words.

What was the big sizzle – his testimony about the Space Shuttle going back years ago – that we've all encountered?

Michael: Well, what he did was, he actually said that he saw on the NASA live feed, an incident involving the Space Shuttle, where there was another craft parked near the Space Shuttle – another spacecraft – and there was at least two different types of astronauts accompanying the NASA astronauts, or the Space Shuttle astronauts, who were out there doing a space walk.

He compared the size of these astronauts from this foreign spacecraft. They were around 10-foot tall compared to the NASA astronauts.

So he had a diagram illustrating what he had seen, and so he spoke at length about this as being evidence that there was a Secret Space Program program with alien astronauts that were somehow collaborating with the NASA space program.

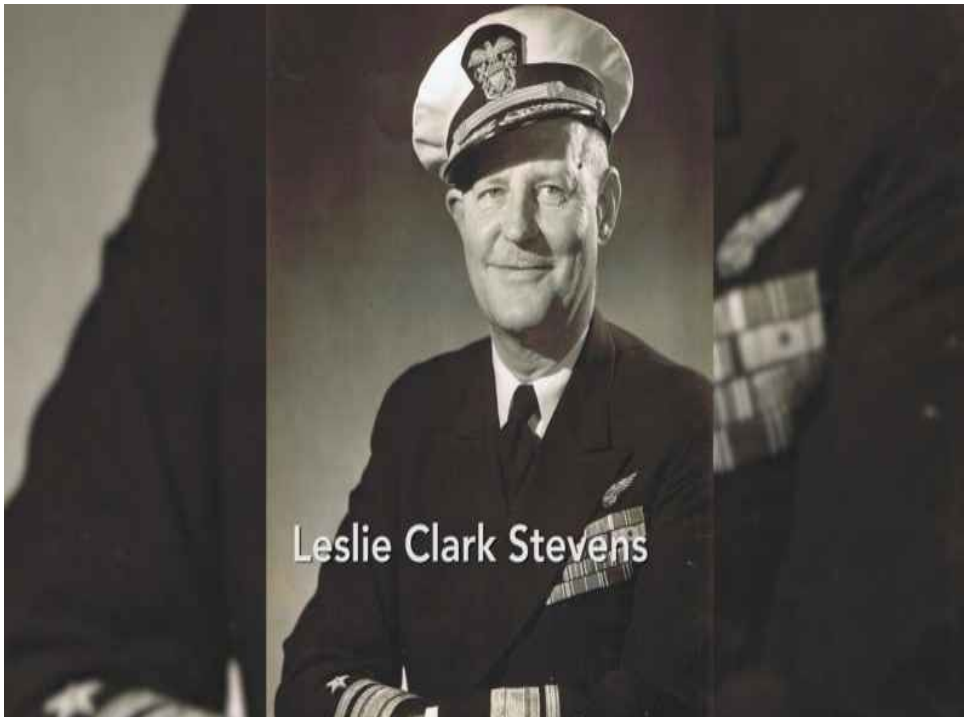

David: So one of the things that you've gotten into, in some of your more recent work, is this idea of how the fictional tales that are told in movies, and comic books, and now video games, of course,

regular books by science fiction authors, like Arthur C. Clarke, Isaac Asimov, how were they being influenced by what was going on from the things you've learned firsthand talking to **Tompkins** and other insiders?

Michael: Well, one of the people that Bill **Tompkins** identified as being a key player in the Navy's development of a secret space program was Admiral Leslie Stevens.

Now, Admiral Stevens, he was actually a contemporary of Admiral Botta, who was running the Navy program out of San Diego, learning all about the Nazi space program.

And what I've been able to determine is that, through Freedom of Information Act [FOIA], that Stevens and Botta actually served together on at least one committee.

So this was something that really supported what Bill **Tompkins** was saying, that Stevens was involved in this and was very familiar with the Navy's Secret Space Program.

Well, the important thing about Admiral Stevens is that he had a son who had the same name, Leslie Stevens, so Leslie Stevens IV. He was the producer of the famous show, "The Outer Limits".





And at that time, around 1964, '65, Gene Roddenberry sat in on the set of “The Outer Limits”, to kind of learn from Leslie Stevens how to put together a science fiction show.

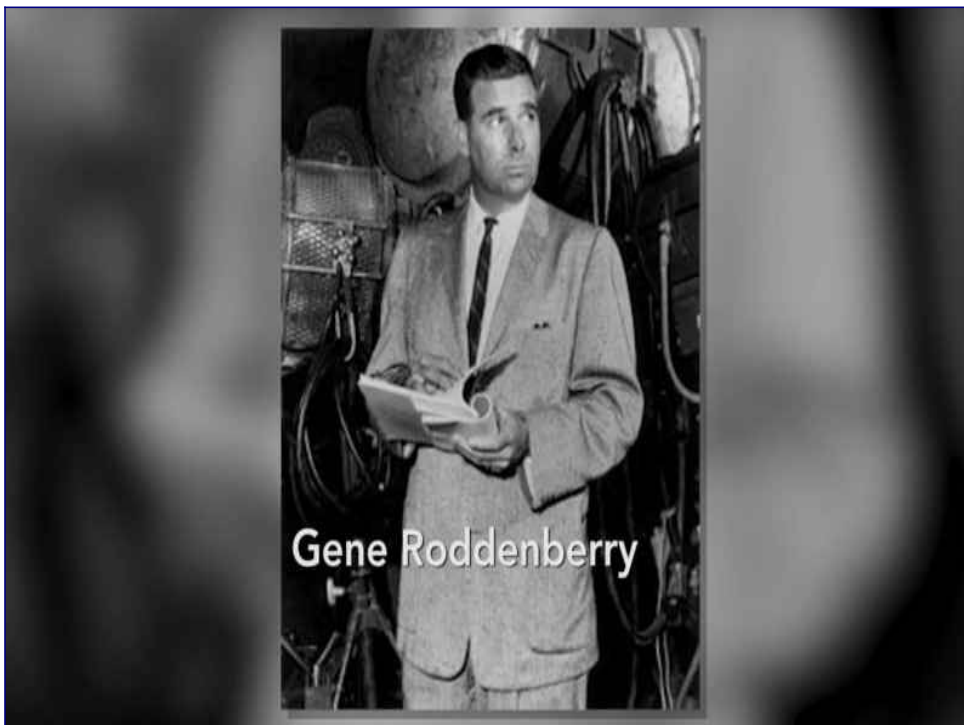

David: Wow! Let me interrupt you just really briefly because this is amazing. So I'm sitting with one of my insiders, who we call Daniel, and he's the guy that allegedly worked at Montauk, where they back-

engineered a seat from a UFO, got it working, and you could sit in the chair, meditate and create a portal that could actually send people through space and time.

And one day he was talking about what happens when you use some of these technologies, and it creates a little orb that can look where you want to have it look.

And he said that the name of this thing was an “outer band individuated teletracer” or OBIT.

And we go online, and I just said, “Hey man, let's just look this up right now, and see if . . . has anybody ever leaked this information?”

“The Outer Limits” . . .

Michael: Exactly.

David: . . . had an episode called “Outer Band Individuated Teletracer” - exactly the same. And then, the actual description of it was that it was a device that could do all surveillance in all places at all times.

So that showed me right away, okay, “The Outer Limits” has got to have some kind of insider connection.

Michael: And one of the things about Leslie Stevens' father, the Admiral, he actually ran the psychological warfare operations for the National Security Council.

David: Wow!

Michael: So he was in charge of that. And Leslie Stevens IV, the producer of “The Outer Limits”, his background was military intelligence. So he actually served for military intelligence, and because of his expertise, I believe that what he did during the Second World War was psychological warfare operations.

So then what I've been able to deduce from my research – and it's in the new book – is that Leslie Stevens IV was basically working with his father, up until his father's death, in psychological warfare operations, in trying to introduce some of these breakthrough ideas as a form of soft disclosure in the

media and entertainment industry.

So when we have “The Outer Limits” being created, you have Gene Roddenberry sitting in on it after the failure of a series that he had earlier put together, which was called “The Lieutenant”.

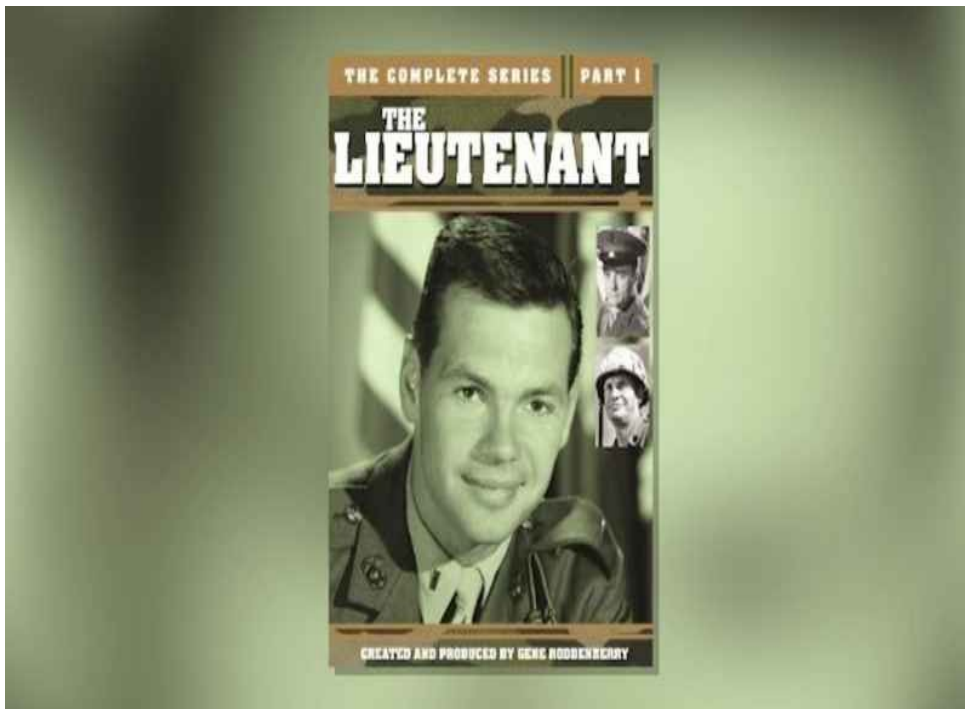

So it was all about a Navy lieutenant. So that flopped. It only lasted, I think, one year, possibly two years.

And so Roddenberry was advised by his agent to come up with a science fiction show.

So he sat in on “The Outer Limits”, and according to people that were there, Roddenberry and Stevens had reached an information agreement, in terms of Roddenberry would get all the information from Stevens about developing his science fiction series, and he would get all the credit – that he wouldn't mention Stevens.

David: Wow!

Michael: And that's exactly what happened. And so then we have, of course, the creation of “Star Trek”.

And if you look at “Star Trek”, some of the main forces, there's an uncanny parallel with the main groups that Bill **Tompkins** was talking about.

So in “Star Trek” you have the Confederation of Planets. You have the Vulcans. The Vulcans, we can compare them to say the Nordic extraterrestrials, trying to help humanity.

You also have the Klingons, who would be represented by the Reptilians today.

David: Wow! Okay.

Michael: And then you have the genetically enhanced humans, which were the Nazis.

So if you look at the development of “Star Trek” as a series, the main protagonist in that series, there's an uncanny resemblance to the major extraterrestrial groups and factions, Earth factions, that were involved in these secret space programs right throughout the 1940s, '50s and '60s.

David: So another show that really pops up in my mind, **Michael**, is “Battlestar Galactica”.



Did your research turn up anything about “Battlestar Gallactica”?

Michael: Well, what was really significant about “Battlestar Gallactica” was that the creator of “Battlestar Galactica” was Glen Larson.



And Glen Larson actually worked under Leslie Stevens.

David: Oh, really?

Michael: He worked with him. They shared a lot of talent. Leslie Stevens was the senior, and so Larson had reached a similar kind of agreement with Leslie Stevens where Stevens would come up with ideas and help Larson in developing a science fiction show.

And what's interesting – and this we've learned from people who have later on interviewed key people that were involved in the creation of “Battlestar Galactica” - was that the pilot episode of “Battlestar Galactica” was actually written by Leslie Stevens IV.

David: Really?

Michael: So you actually have the son of a Navy Admiral that was involved in the Navy's Secret Space Program, writing the pilot episode for a new sci-fi series that he would not get any credit for, but would actually go under the control and be all credited to Glenn Larson.

David: Wow!

Michael: And so, again, this kind of shows that the Navy, through Leslie Stevens, was wanting to have these ideas, the truth of a Navy Secret Space Program and different forms of extraterrestrial life, including artificial intelligence, because that's what "Battlestar Galactica" really focuses on, is the danger of artificial intelligence.

And so Glen Larson, in that series, just developed the whole idea of extraterrestrials that are having to deal with this conflict with different AI life forms who are intent on eradicating the human creators of that life form throughout the galaxy.

And this is something that kind of dovetails with what **Corey** has revealed. I remember **Corey** talking to great length about the danger posed by artificial intelligence, and how AI was screened by the different secret space programs because of the threat.

So this, again, is just confirmation that this was very real material that was being seeded into the public domain through these movies.

David: Do you think . . .

Corey: The truth is definitely stranger than fiction.

David: Do you think that this Leslie Stevens connection is why you hear Naval whistles when people walk into the room on "Star Trek"?

Michael: Oh, definitely. Yeah, I mean, you look at "Star Trek" itself, I mean, it's all based on this, kind of like, . . . they use Navy procedures and the rankings are Navy.

David: Right.

Michael: The Star Fleet – they talk about Star Fleet Command and all of that. So, yeah, they use a lot of Navy terminology in "Star Trek", and I believe that's because the Navy was getting Stevens to leak this stuff out into the public arena through soft disclosure.

Because I think what the Navy really thought, through the 1960s, that eventually, by the time that they

had finished building their battle groups that were deployed in the early 1980s, that disclosure would have happened by then.

David: Oh.

Michael: So I think that “Star Trek” was part of an effort by the Navy to kind of seed these ideas into the public consciousness, so that at some time in the future, when the truth was revealed that the Navy had the know-how to build these space battle groups, that the public would come on board and support it, and so the Navy could continue to develop this and expand it.

David: So **Michael**, I have some documents here that show some really amazing work that you've done in terms of taking the **Tompkins'** story that we've all been dealing with now, and bringing it into this Freedom of Information Act academic research arena that ufology is known for.

So the first one that you have here . . . it's from U.S. Naval Air Station San Diego signed by Rico Botta.

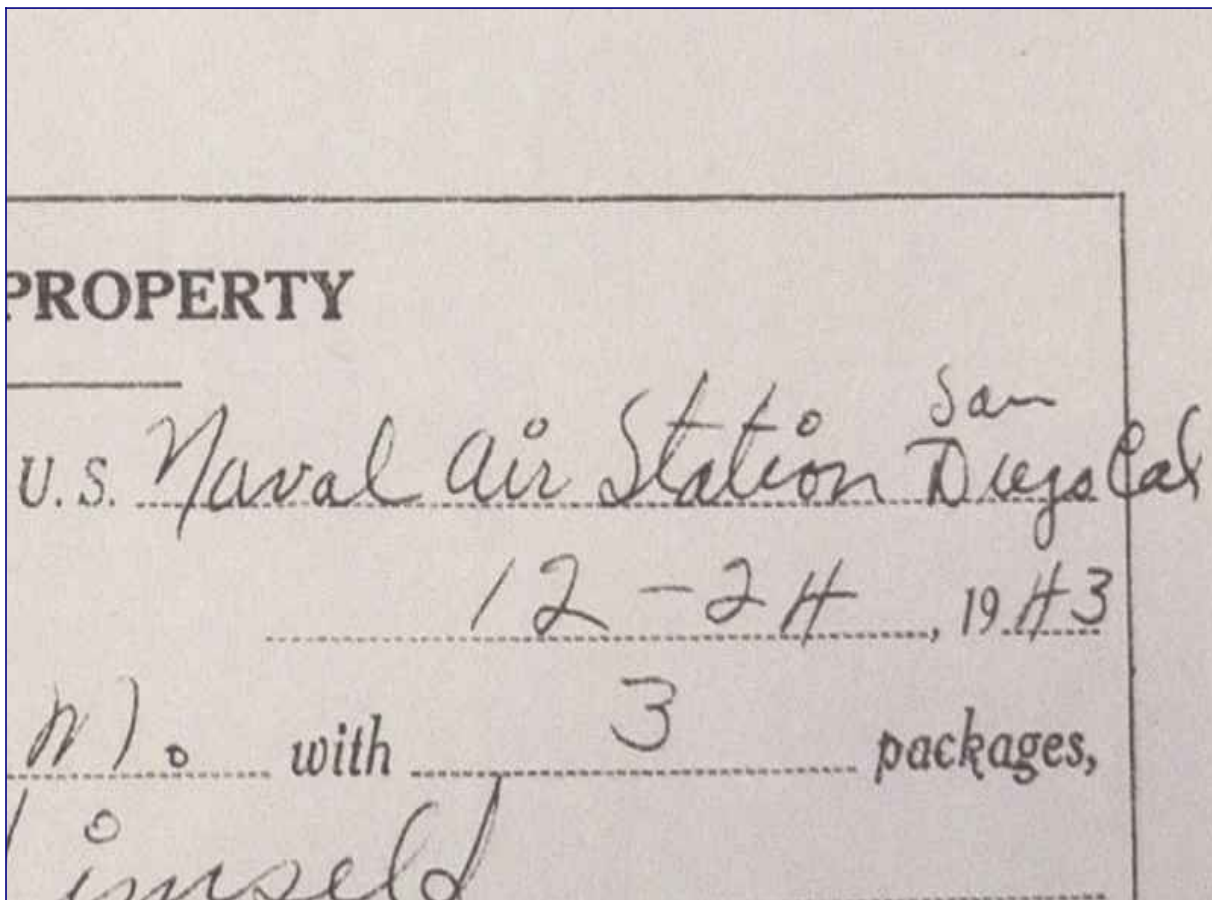

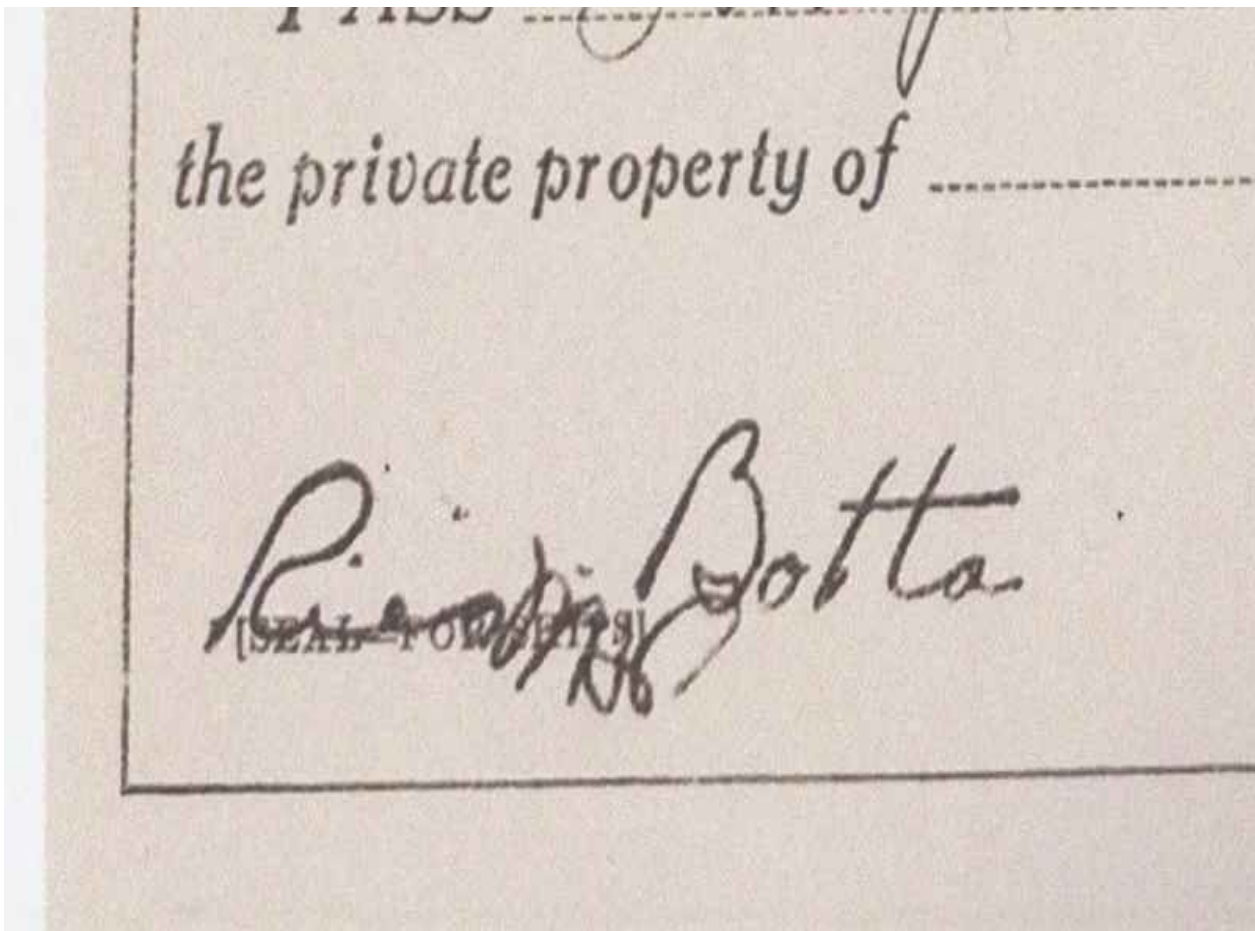

So what's going on here with this particular document?

Michael: Well, with this document, this was something that **William Tompkins** put into his book, “Selected by Extraterrestrials”, and basically these were exit slips that he could use to be able to leave Naval Air Station San Diego with documents, with briefing packets, which is a key part of his story.

David: Right.

Michael: But in terms of verifying, well, is this real? Are these exit passes real? Do they have information on them that can be independently corroborated?

So that's what I tried to do, and I used the FOIA Information Act documents that I received to corroborate that these exit passes were actually signed by a person who actually was in charge of Naval Air Station San Diego at the time that **Tompkins** said that he received the permission to take these packages out. And then that, of course, concerns Rico Botta.

No. 76 U.S.N.A.S. San Diego, Cal.
Apr. 17, 1944
 PASS Tompkins, W. M. with 1 packages,
 the private property of Himself.
Four issues of Non-Combat
airplane.
 SEAL FOR TAPE Ricci Botta
 J. M. Brundred, Srs., U.S.N.A.
 U.S. GOVERNMENT PRINTING OFFICE 8-527

PRIVATE PROPERTY
 No. 56 U.S. Naval Air Station San Diego
12-24 1943

PRIVATE PROPERTY
 No. 56 U.S. N
 PASS Tompkins W. M.
 the private property of Him
Ricci Botta
 (SEAL FOR TAPE)

David: It says here that it was for “issue of non-combat airplane.” Ha, ha.

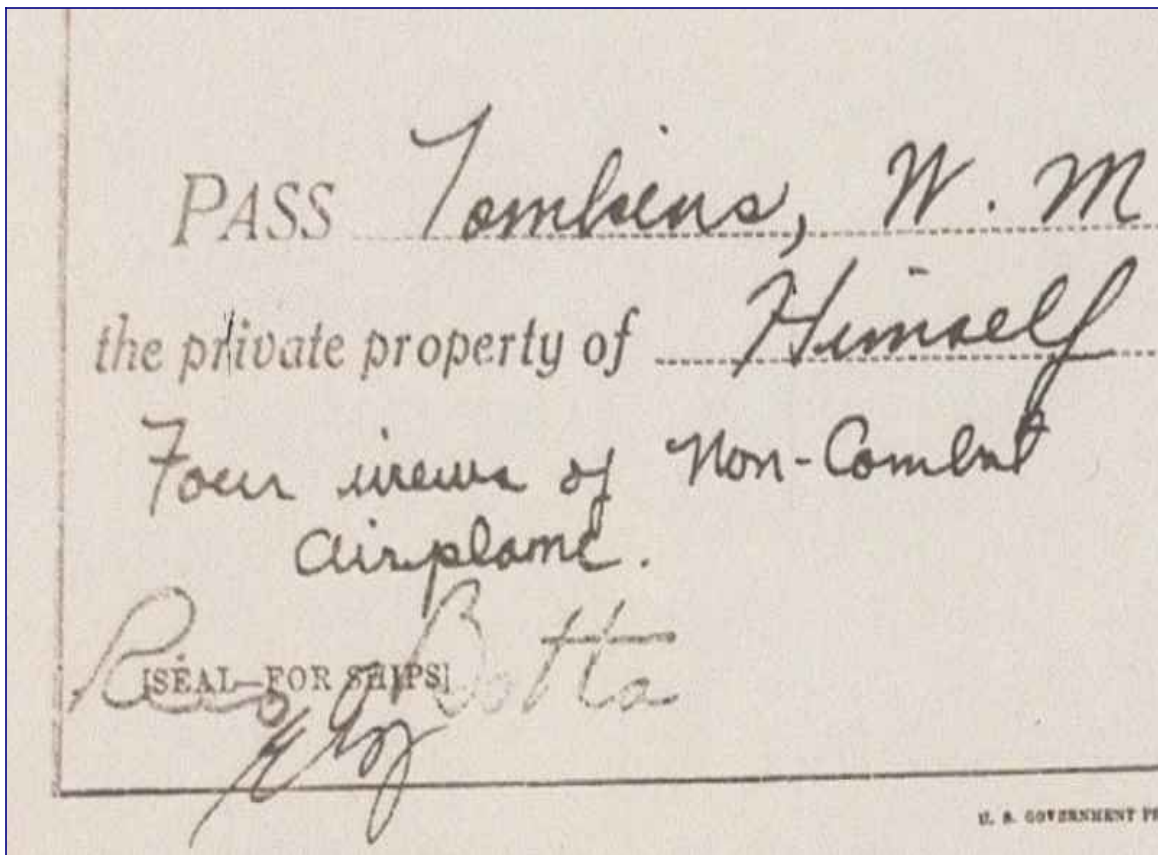

Michael: Well, that's right.

David: So what the heck is that?

Michael: Yeah, well, what that document shows is that **Tompkins** not only was given permission to take these briefing packets out of Naval Air Station San Diego, but he was also given permission to use a plane – to take an actual non-combat plane that was owned by the Admiral – to deliver these packages.

So this is corroborating a key part of **Tompkins'** story that he took these different briefing packets to various aerospace companies throughout the U.S., especially the west coast of the U.S. at the time, the different military departments and so forth.

So it's really . . . Corroborating this document helps determine some key elements of his testimony.

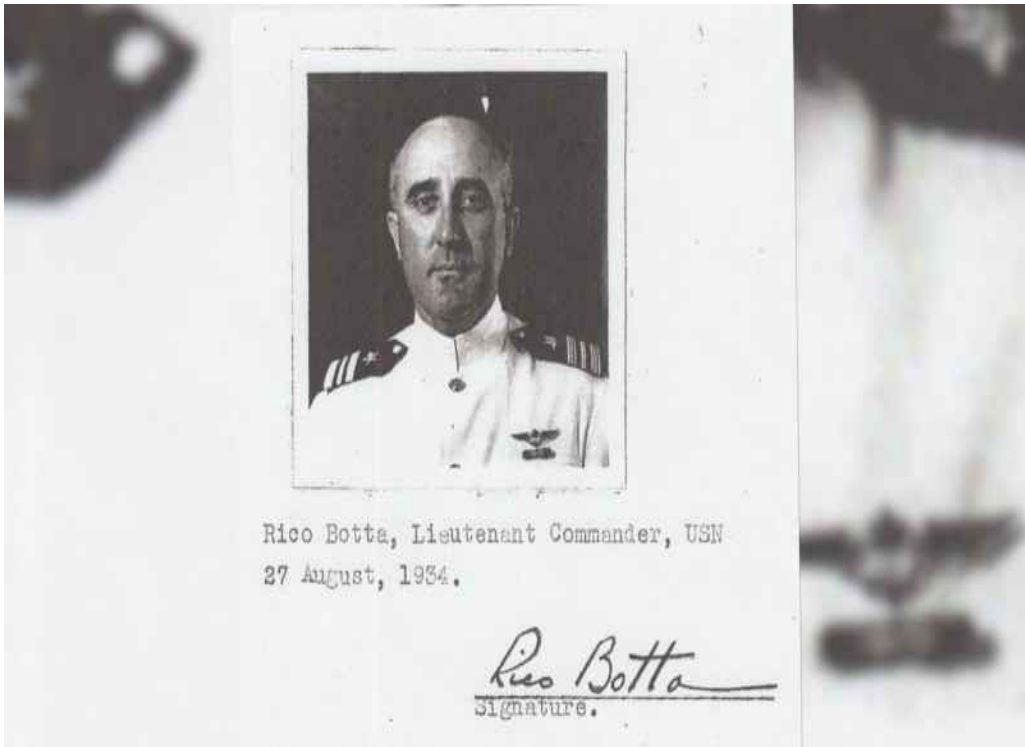

David: Okay, now here we have a photograph of Rico Botta, Lieutenant Commander of the U.S. Navy, August 27, 1934, and then his signature.

Comparison of signature from Rico Botta file photo (1934) released by FOIA with signatures on Bill Tompkins exit passes (1943 & 1944)

Rico Botta, Lieutenant Commander, USN
27 August, 1934.

Rico Botta
Signature.

Passes for travel to/from Naval Air Station with packages signed by Admiral Rico Botta
Source: William Tompkins. Selected by Estraterreshlah, p. 68

National Archives File Photo Released by Freedom of Information Act

And what's so interesting about this, **Michael**, is that in this next document you showed us, you have compared that signature on that photograph to the signature that was on the release for the packages, and they're basically identical. I mean, it's the same signature.

So how did you get this picture of Rico Botta? Where did that come from? Let's talk about that first.

Michael: Well, that picture of Rico Botta, that came from his Freedom of Information Act files, the 1,500 pages of documents that I received.

David: So you filed for them, and you actually got them in the mail?

Michael: I filed with the aid of an attorney.

David: Okay.

Michael: His name is Duke Brookhouse and he has been helping with these FOIA requests.

And so, when we got the documents, I went through them and identified the ones that helped corroborate key elements of **Tompkins'** story.

So this particular document, with his signature and his photo – even though it's dated from the early 1930s – clearly shows that the signature is identical with what was on those exit passes that **Tompkins** gave.

So that is independent corroboration that **Tompkins'** document is genuine. And that's very important that you actually . . . **Tompkins'** exit passes . . . those two exit passes showing that he had permission to take these briefing packets out of San Diego Naval Air Station, that that's a genuine document.

So that's a very important part of corroborating his story that he was able to take these to different facilities, and that he was given permission to actually use an airplane to fly these to the different locations.

In reply address not the signer of
his letter, but Bureau of Navigation,
Navy Department, Washington, D. C.
Refer to No.

Pers-313-JLK

NAVY DEPARTMENT
BUREAU OF NAVIGATION
WASHINGTON, D. C. September 30, 1942
(NOW BUREAU OF NAVAL PERSONNEL)
T-12455

From: The Chief of Naval Personnel.
To: Captain
Rico Botta, U.S.N.,
Bureau of Aeronautics,
Navy Department.

Via: The Chief of the Bureau of Aeronautics.

Subject: Temporary additional duty.

1. Proceed to the place (or places—in the order given)
indicated below, for temporary duty. This is in addition to your

David: Okay. Now, the next one here, it says Navy Department, Bureau of Navigation, Washington, D.C., dated September 30, 1942, from the Chief of Naval Personnel to Captain Rico Botta.

And the thing that really jumps out at me here, it says, “Proceed to the place (or places – in the order given) indicated below, for temporary duty.”

Via: The Chief of the Bureau of Aeronautics.

Subject: Temporary additional duty.

1. Proceed to the place (or places—in the order given)
indicated below, for temporary duty. This is in addition to your
present duties and upon the completion thereof you will return to
your station:

On or about October 1, 1942, to Los Angeles, Calif., via
commercial aircraft, and thence to the following places and such
other places as may be necessary, in connection with inspecting
experimental aircraft and for conferences in connection with air-
craft matters:

- U.S. Army Air Force Experimental Station,
Muroc, Calif.
- Douglas Aircraft Company, Inc., El Segundo,
Calif.
- Northrop Aircraft, Inc., Los Angeles, Calif.
- Naval Air Station, San Diego, Calif.
- Consolidated Aircraft Corporation, San Diego,
Calif.

2. You are authorized to omit or modify any of the above

And then you look down here, it says that this is “in connection with inspecting experimental aircraft and for conferences in connection with [**David** clears his throat to emphasize this part] aircraft matters:”

Then you get this list of “U.S. Army Air Force Experimental Station, Muroc, which we've all heard about the Muroc base, Douglas Aircraft, Northrop, Naval Air Station, San Diego, Consolidated Aircraft Corporation, San Diego.”

This is crazy. What is he talking about with “experimental aircraft and conferences in connection with aircraft matters?”

Michael: Well, this is, again, another document that independently corroborates various aspects of **Tompkins'** testimony, that **Tompkins** says that he was taking these briefing packets to those facilities, as well as many others.

So this document confirms that Botta, prior to this operation that Botta oversaw in Naval Air San Diego, Botta had traveled to some of these same facilities, and that these facilities were conducting experimental aircraft research. And that Botta was the Navy's guy when it came to understanding experimental aircraft research, and that Botta was being prepped for this new assignment, because visiting those facilities happened less than two months before he was transferred over to Naval Air Station San Diego.

So he was being prepped for that new assignment coming up, where he would be receiving intelligence from Navy spies in Germany about the Germans' secret space programs. And that once he received the intelligence from the Navy spies, that he would then instruct **Tompkins** to carry briefing packets to those facilities that you just mentioned, as well as many others that **Tompkins** said.

So, you know, again, this is another important document that independently verifies that Bill **Tompkins'** story is credible. And, of course, . . .

David: How did we get this document?

Michael: That came through the Freedom of Information Act.

In reply address not the signer of this letter but Bureau of Aeronautics, Navy Department, Washington, D. C.

NAVY DEPARTMENT
BUREAU OF AERONAUTICS
WASHINGTON

37475-164
1/19

Refer to No.
Aer-PE-12-LC
00/Botta, Rico

From: The Chief of the Bureau of Aeronautics.
To: The Chief of the Bureau of Navigation.

FEB 25 1942

SUBJECT: Orders—temporary additional duty.

1. It is recommended that orders for temporary additional duty be issued to the following personnel as indicated:

Name	Rank or Rating	WRITTEN DISPATCH Present Station
✓ BOTTA, Rico	✓ Commander, U.S.N.	✓ BuAer

David: Okay, so another document we have here is dated February 25, 1942, which, for the real UFO freaks, you're going to know that, because that is immediately after the infamous Battle of Los Angeles.

From: The Chief of the Bureau of Aeronautics.
To: The Chief of the Bureau of Navigation.

FEB 25 1942

SUBJECT: Orders—temporary additional duty.

1. It is recommended that orders for temporary additional duty be issued to the following personnel as indicated:

Name	Rank or Rating	WRITTEN DISPATCH Present Station
✓ BOTTA, Rico	✓ Commander, U.S.N.	✓ BuAer

7-20568

From: Bureau of Aeronautics, Washington, D. C.

Date to proceed: On or about 2 March 1942

Via: Naval Aircraft, or commercial, ~~commercial air~~

To: Wright Field, Dayton, Ohio, reporting to the General Inspector of Naval

Thence via: Naval Aircraft, commercial, commercial air, Aircraft,

To:

Thence via: Naval Aircraft, commercial, commercial air.

And what we're having here is Navy Department, Bureau of Aeronautics, from Washington, and it is orders for Rico Botta to have additional temporary duty. And it says for him to proceed, on about March 2, 1942, to Wright Field, Dayton, Ohio, i.e. Wright-Patterson Air Force Base.

Michael: Exactly.

David: Holy crap! This is amazing!

Corey: Smoking document!

David: Ha, ha. I just want to throw it across the room, it's so crazy. It's like, wow! So talk . . . I know what I'm seeing here, but talk us through, in case people aren't as excited as I am right now, as to why this is so significant.

Michael: Well, February 24 and 25, 1942, is when you had the famous L.A. Air Raid incident. And according to documents that have been released, The Majestic Documents, and according to what Bill **Tompkins** has said, there were two flying saucers that were retrieved after that crash – one by the Navy, one by the Army Air Force.

David: So some of them did get shot down.

Michael: That's what we're told by The Majestic Documents and what Bill **Tompkins** said.

Now, the one that the Army Air Force got their hands on was taken to Wright Field, which was, at the time, the Army Air Force's premier research facility for foreign aviation technologies.

David: “Foreign.” Yeah, ha, ha.

Michael: So this was taken, . . . or this craft was retrieved, on February 25, and it was being taken to Wright Field at that time.

Now, on this very same day, Admiral Botta, who is the head of the Navy's Powerplant Division at the Bureau of Aeronautics, gets orders to travel to Wright Field in early March, to basically do some work over there.

David: Right.

Michael: And the timing . . .

To:
Thence via: Naval Aircraft, commercial, commercial air,
To:
Thence via: Naval Aircraft, commercial, commercial air,
To:
Thence return via: Naval Aircraft, or commercial, commercial air,
To: Washington, D. C., and resume regular duties.

(a) Reason: In connection with engine development.
(Chargeable to Aviation, Navy, 1942 - Subhead One)

(b) Estimated period of duty: 2 days
(c) Estimated cost: \$85.44 if via commercial
(d) Estimated delay in excess of 72 hours at:
(e) It is recommended that these orders be: delivered by 28 February 1942

28

David: It says, "In connection with engine development." on the same document. What kinds of engines are they trying to develop here?

Michael: Right, so . . .

David: Probably anti-gravity. So, yeah.

Michael: So that's a smoking gun document . . .

David: That's incredible.

Michael: . . . that really shows that Botta was the guy that the Navy had tapped as their expert in understanding these foreign technologies – anything to do with extraterrestrial craft or Nazi craft – that Botta was the man.

And so he was nominated to go to Wright Field to really look over what it was that the Army Air Force had gotten their hands on from the L.A. Raid.

Corey: And did you say that, in an earlier conversation we had, that Rico Botta was an engineer?

Michael: That's correct. Yes, he was an engineer. He was an expert on engine development, on power plants.

Corey: Power plants.

Michael: He was, actually at the time, the Chief of the Power Plant Division for the Bureau of Aeronautics. So he was the guy that really understood what it was that needed to be done in terms of developing high-capacity engines for high-performance aviation maneuvers.

And so if you're talking about craft that were capable of spaceflight, he was the guy that would be able to give you insights into that.

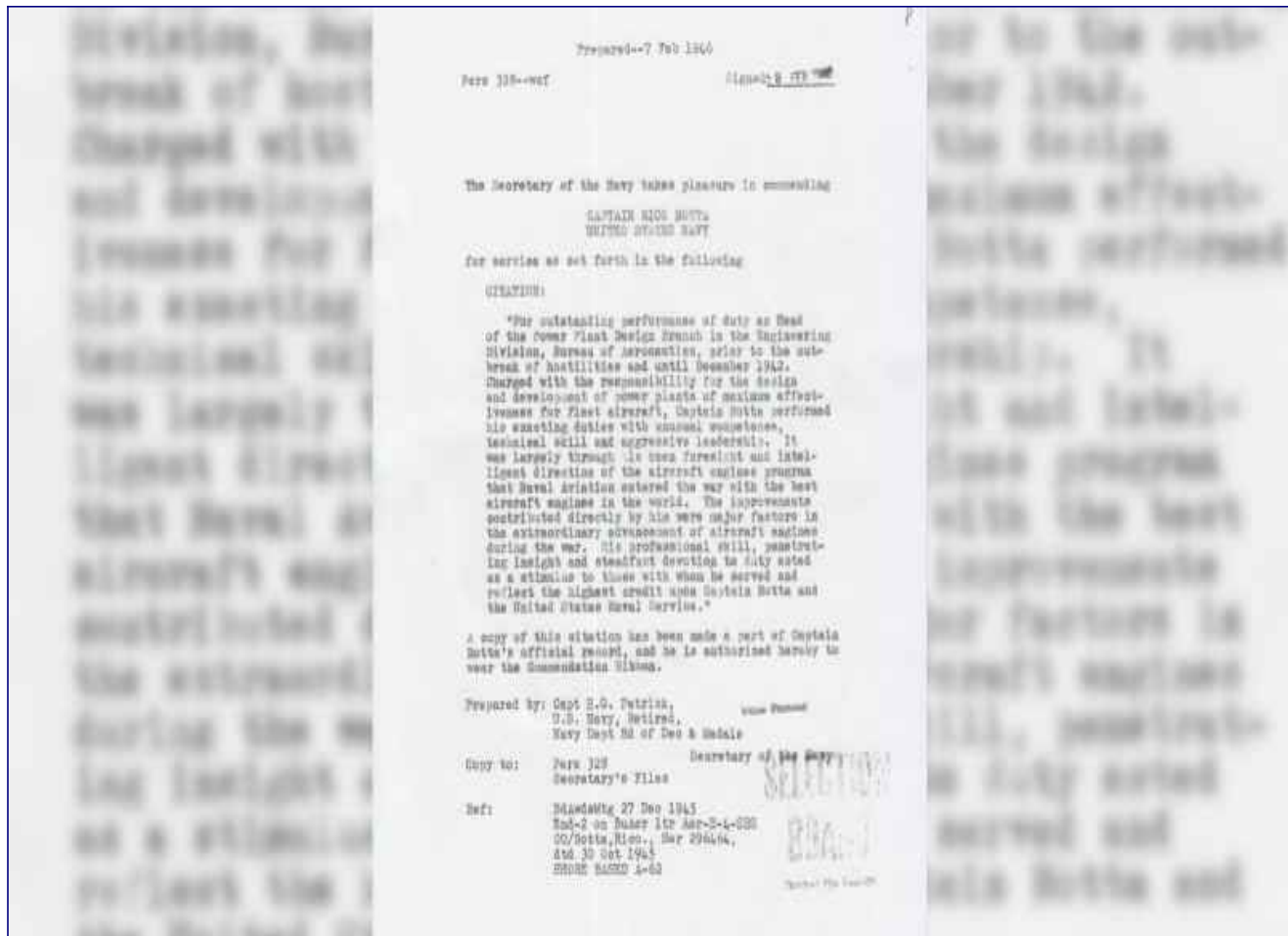

David: Right, and you have this document right here from March 15, 1946, where it says that, "his outstanding technical knowledge and skill, Rear Admiral Botta enabled his department , , , " blah, blah, blah ". . . for combat aircraft . . . with the latest combat-improved changes . . ."

"For exceptionally meritorious conduct in the performance of outstanding services to the Government of the United States as Assembly and Repair Officer, United States Naval Air Station, San Diego, California, from December 31, 1942, to August 14, 1945. By his outstanding technical knowledge and skill, Rear Admiral Botta enabled his department to meet the ever increasing demands of the Fleet Air Commands for combat aircraft of the latest type and with the latest combat-improved changes installed. In addition to accomplishing a great increase in personnel and output, this department, under the able direction of Rear Admiral Botta successfully undertook and completed many emergency projects, thereby making a material contribution to the successful prosecution of the war. His conduct throughout was in keeping with the highest traditions of the United States Naval Service."

So it's clearly . . . You have documents here saying that he's involved in upgrading the quality of technology of combat aircraft engines and energy technologies.

Michael: Right. Exactly. That was his duty while he was working at Naval Air Station San Diego from 1942 to 1946, that he was the assembly and repair officer.

And so his job was to basically upgrade the performance of all the Navy jet fighter craft.

And in addition to that, he was also learning about what it was that the Nazis were doing in developing jet engines and also trying to weaponize flying saucers, because you had to consider that the Navy had to be prepared that the Nazis were going to succeed in developing weaponized flying saucers.

So the Navy was looking to Botta to provide the expertise and the leadership for how to deal with that contingency. But it didn't happen, fortunately, but Botta was the guy that the Navy had tapped to lead that effort.

David: You also have actually interviewed people associated with Rico Botta, and so could you tell us a little about that and what, in just a few minutes, is the most interesting takeaway of your research, up until now, in that department?

Michael: Well, I've been able to have conversations with the grandson of Rico Botta, who was able to confirm some really interesting things about Botta's contacts with the leaders of the aviation industry at the time, that he was personal friends with Jack Northrup and **William** Boeing, that Botta was also someone that continued to meet with senior Navy officials.

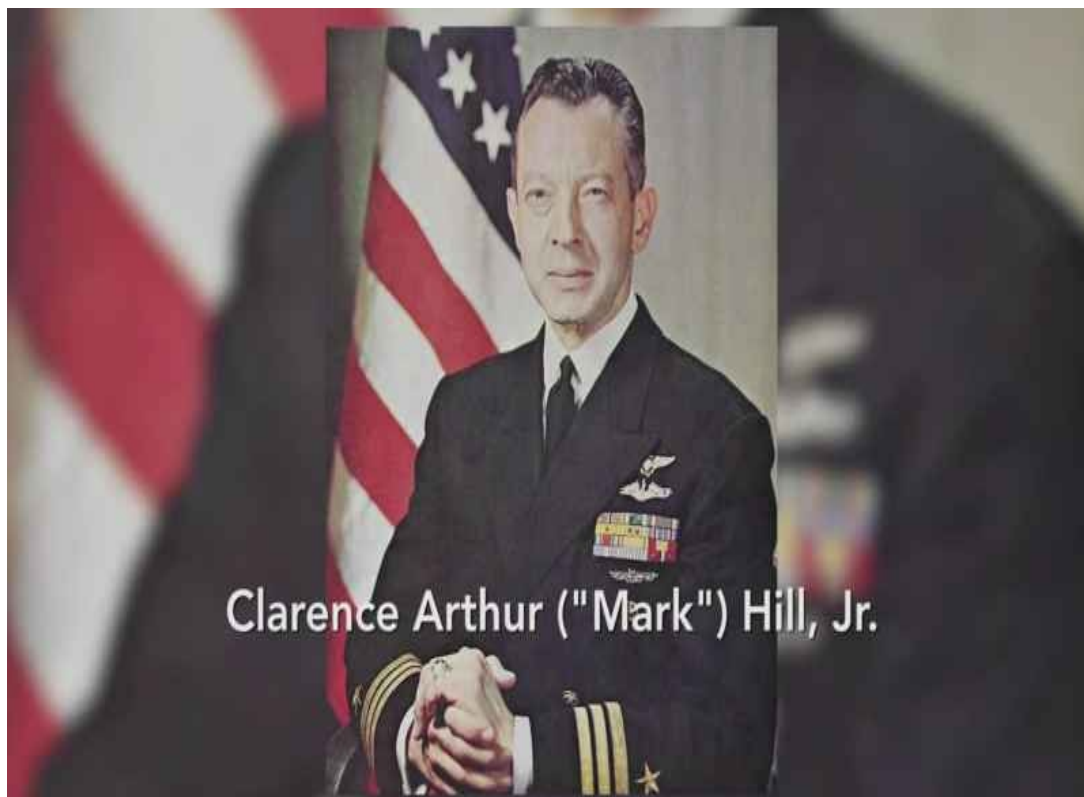

One official that was named was Admiral **Mark** Hill, who was Botta's military aide while Botta was the head of the Navy's Armaments Section at Philadelphia Naval Shipyards, that **Mark** Hill was helping Botta there as his military aide, and that after Botta retired, that **Mark** Hill, as an active officer and he became a Rear Admiral himself, continued to visit with Botta and have conversations.

And so, to me, that's pretty strong evidence that Botta's insights and knowledge about these very advanced technologies was something that was being shared, even up until the time of his retirement and subsequent death, with very senior Navy officials.

David: What do you think is going to happen with this forensic reconstruction of history in time? Will we be able to eventually get new insiders, and new whistleblowers, and really get a reconstructed view of 20th century history? Do you think that will happen?

Michael: Oh, definitely. Yeah. I think that's what's happening now, is we're starting to get the chronology of how the Navy developed its Secret Space Program, involving these enormous space battle groups, and that as these names are identified, and we start to track down relatives or others that worked with them, we're probably going to find others that are willing to talk about what it was that they experienced.

So we're trying to do that now, and I'm hoping that in this investigation of Admiral **Mark Hill** and Admiral **Botta** and his relatives, that we're going to have more names popping up.

David: Corey, do you have any last thoughts before we close the episode?

Corey: It's been amazing to me, the entire process of **Tompkins** coming out. He's literally providing the information, or a lot of the information, I observed in the glass pad. And to see someone come out that was giving that intel, or delivering that intel, it's a very strange synchronicity.

And the fact that he had no idea I was coming forward – all of it seems orchestrated.

David: And we're now getting this actual nuts and bolts documentation – connecting dots, interviewing survivors – to actually show forensic reconstruction of the whole history of what led up to you eventually being in something that most people think is just completely outrageous and beyond belief.

Corey: Absolutely. And Dr. Salla's latest research is just bolstering it more and more.

David: Well, I want to thank you, **Michael**, for coming in. I think these are really groundbreaking episodes that will be of extreme historical importance as we get into Full Disclosure.

And I want to honor you for your contributions in really bringing the academic spectrum in on this whole question of our "[Cosmic Disclosure](#)" show.

Michael: Thank you, **David**. It's been a pleasure. And thanks, **Corey**.

Corey: Thank you.

David: Thank you. And I want to thank you out there for watching. You are a very important part of "[Cosmic Disclosure](#)". With your support, telling your friends about it, we are lifting the laughter curtain. We are bringing real academic interest into something that was so far outside the norm of what

UFO researchers used to talk about, and yet, as you're seeing, it all adds up beautifully.

This is “Cosmic Disclosure”. I'm your host, [David Wilcock](#), here with **Corey Goode**, and our special guest, from Exopolitics Institute, Dr. **Michael Salla**. Thank you for watching.

Cosmic Disclosure: Viewer Questions Part 6

Season 7, Episode 12

David Wilcock: All right, welcome back to “[Cosmic Disclosure](#)”. I'm your host, [David Wilcock](#). I'm here with our insider's insider, **Corey Goode**.

Your questions, as I've said so many times, shape and influence this show.

Corey, are you ready to handle some audience questions?

Corey Goode: Good to go.

David: Let's dive right in and hit this. “**Corey** states that he has been picked up by a blue orb. I physically have seen a yellow orb with my son three years ago. He was seven at the time. He called it 'a starship' and started running towards it. It was not small, and it made no noise.

“I looked at my son, and it was gone. I have a hard time understanding why I froze, but my son knew what it was. Can you explain what a yellow orb is?”

It sounds to me like this is actually a UFO sighting. It just might have had yellow light.

Corey: Yeah. Sounded like it was a actual UFO sighting.

And we've talked before about there's all different types of orbs. And none of them have . . . They're not necessarily interrelated with each other.

A lot of times, if an entity, a disembodied entity, or a spirit appears, it will appear as a orb – different types of orbs.

I had a friend tell me one time that he was hunting, and he saw a red orb floating around. And probably four years later, I was with a friend, hunting, and I looked over in a cornfield, and I saw a basketball-sized red orb that looked like it was on fire inside of a crystal ball almost, just floating like it was scanning the field looking for something.

And then it just floated off and disappeared. I have no idea what that was.

David: All right. Well, let's keep going along here. We're going to try to get through a lot of these.

The next one we have is Leannaarts, “**Corey and David,**” - so I guess this is open to both of us - “what are your thoughts on the idea that not only is the Earth a prison planet created by Reptilians, but that we are tortured by these beings after we die and encounter them in other dimensions? That they created religion, money magic system, and a magnetic Earth force field to control us, and a Moon operation to wipe our memories?”

Corey: I think we're crediting the Reptilians with a little too much, to be honest.

David: This is widely divergent with my own belief system, of course.

Corey: Right. There are a number of nonterrestrials that are using this planet as a petri dish that they are doing experiments in.

Yes, it is a prison planet. We're basically free-range slaves running around, thinking we're free, and that we have all this knowledge of the universe.

Now, the Reptilians and these . . . There's various other groups that we've been in contact with that have been contributing to what's going on here on the planet.

And we can't attribute all of it to the Reptilians because they've just been a small part.

David: Would you say that ultimately, negative extraterrestrial intelligence is responsible for creating UFO religions like this, because if someone were to be coming from a place where they believe what this question says, that they would generate loosh?

Corey: Yeah, they're exploiting our genetically and socially programmed biases. We create religions ourselves. And they see how much those religions control us.

So, yeah, why wouldn't they give a little boost to a religious idea?

David: So we have another question now from Leahahuman. "Please talk more about the art and culture of ET people. It is very nice to hear that the people of Earth are being recognized for their creativity."

So this seems to be in relation to what we've been calling, for lack of a better term, the Micaites, who you met.

Corey: Correct, yes. And not only through Mica. This bartering, this galactic bartering system that we have with other civilizations, has included them wanting works of art, you know, statues.

You know, art that may have gone missing in World War II could be hanging on a wall in another solar system right now.

So yeah, we're very creative. They love that about us. And they are creative as well and have their own art to share with us.

David: The space program insider, Jacob, who has been so helpful for years in giving me lots of intel, corroborated very nicely with what you have to say. And he explained meeting certain types of extraterrestrials in which he said they were very boring people, and that any one of them that you meet, it's like you're talking to the same person. They all see very similar to each other.

Do you think there is some reason for why humans on Earth might have greater diversity in their personalities and potentially greater creativity than some of these extraterrestrial civilizations that are out there?

Corey: I think what you just described would be the minority.

David: Okay.

Corey: But, yeah. I mean, all the genetic tinkering that we've had happen to our species has created a . . . All of them have very strong emotions, but they're usually a very fixed, narrow band of emotions.

David: Similar to like the Vulcans in “Star Trek”?

Corey: No. They're non-emotional.

David: Right, okay.

Corey: They love, but they love hard, and they experience love differently than we do.

With us, we have such a wide range of emotions that it's a benefit and a detriment to us. We can't control our emotions.

Once we learn to control our emotions and channel it into creativity, then, . . . I mean, we haven't even begun to create what we're capable of.

David: Do you think there might be some sort of primordial darkness in the human soul here on Earth based on this idea, as you said, that it might be akin to a prison planet, that perhaps that grist for the mill is generating greater creativity, greater quality of art, than we might see in a more utopian type of civilization, where they don't have that level of pain?

Corey: Yeah, that's very possible.

David: I would think so. We now have Gymratt89.

“Hey, **Corey**. To your knowledge, is there any intuitive empaths, personality metamorphs, etc., that have slipped through the cracks or have managed to keep a low profile and remain off the radar or undetected from MILAB recruiters, government or Cabal groups?”

Corey: Yes. With the personality metamorphs, they're so difficult to train and work with. Many of them make it just a little bit through the program, and then they're blank slated and kicked back out to society.

So there are a lot of personality metamorphs out there. And if you're an intuitive empath, if you're not

discovered through some of this testing or through family lineage that's being observed, then there's a very good chance that you're not going to end up on the radar.

David: You mentioned that there are an increasing number of people who have had a blue orb experience. And then they don't know what the heck that is, and they Google it up, and they find our show, and then they're writing you.

Do you think, based on this question, that those people are necessarily all being identified? Or is it possible that some of that is happening off the radar as well?

Corey: A lot of it's happening off the radar, but the blue orbs are usually visiting people to awaken them to why they're here.



I sent you a video. People are speaking Spanish in the background, and there are blue orbs just flying around. And they're gasping and talking about it.

And those types of shows are done to awaken people.

David: So when you say “awaken”, is it possible that some sort of DNA activation or consciousness quickening is taking place that would create an intuitive empath in someone who may not have had that ability before?

Corey: No, I think it's basically reminding people of who they are, and what they're here to do on a subconscious level.

They don't consciously go, "Oh, wait a minute. I'm an alien. What am I doing here?" You know, "it's time to get to work."

David: Right.

Corey: It's all happening subconsciously, but it's a catalyst.

David: All right. Let's go with another one here. This is UFO22:

"Question for anyone." I guess that means I could take a crack at this myself, but that's not really the format of our show.

"How did Sigmund and the lower-level program group learn about **Corey** in the first place? And what was the technology/mind control methodology used to get him from his house to their ship, where the chemical interrogations took place?" So that's really two questions.

Corey: Right. Well, they found out about me from all of the chatter that's occurred since we began this show. This MIC group is Air Force, and they are given a totally different briefing than a lot of the people in these other secret space programs.

And what I was saying was matching to a certain point, but then, again, a lot of the stuff I was saying they couldn't buy into because it wasn't a part of their briefing.

So therefore, they decided that they were going to pay me a visit and gather a little bit of intel and find out what's going on.

And the second part of the question, how do they control you to make you walk outside of the house on your own?

They have technologies that control the mind and autonomic systems of the body. They can make you breathe faster, or they can speed up or slow down your heart. They can make you get up and walk or

open doors. They have the ability to do it.

Scientifically, I don't know the specifics. That's probably more of a **Pete** Peterson question.

David: They can't just take us over like a remote control robot and make you walk and actually move your legs with a joystick or something.

Corey: Yeah, they can.

David: Oh, they can do that?

Corey: Yeah.

David: Okay. So this must be way more powerful than what regular human telepathy is capable of.

Corey: Right. I mean, they're going to be able to get you up on your two legs, walking, get you opening the door. And a lot of it has to do with once they get your body in motion, your mind subconsciously starts to, I guess, go along with it. It's natural, you know?

When you reach for a doorknob, your mind and body . . . you don't have to sit there and tell yourself, "Turn the door knob." It just happens.

So they're kickstarting that part of your brain.

David: Well, in disclosing something that contentious, I would be concerned about the fact that there are a lot of people out there who could be diagnosed with schizophrenia, who would then be inclined to take something that you just said and think that their motions are being remote controlled.

We have a lot of people who believe that they're being gang stalked, for example, when in fact their symptoms are totally consistent with paranoid schizophrenia.

So given the fact that there's only a total of 800,000 people in all branches of the intelligence community, how widespread do you think this really is, because a lot of people might be inclined to think that they're being singled out, or that they're being remote controlled this way?

How many people do you think might actually be getting this kind of stuff happening to them?

Corey: The nonterrestrials use it in abductions. It is something that we got from them, that we reverse engineered from them.

David: Okay.

Corey: It is something that is from a higher civilization, that knows the physiology patterns of all of the life in the universe – or in the galaxy, at least. And manipulating it, it's child's play for them.

David: I guess my question really is about the people who are going to maybe have panic attacks and think that they could just be possessed by this technology at any moment in their lives.

Corey: Well, you know, you're always going to have those types of people. Any time I mention anything, people that have personality distortions or chemical imbalances are going to take the information in through their filter and apply it, and there's nothing we can really do to prevent that.

David: And I guess that's part of the problem with Full Disclosure, isn't it? There's going to be all kinds of delusions and paranoid fantasies that people can start to have that they have been singled out.

And typically, when you encounter these types of people, they believe that because they're aware of some of the truth of what's going on with the Cabal, that the Cabal is actually after them, that they're being followed.

But I don't really think most of the people that are learning about this on the Internet are actually being singled out by the Cabal for surveillance, that kind of stuff.

Corey: No.

David: So could you speak to that a little bit?

Corey: Yeah, I mean, it's pretty rare to be targeted like that. You have to be more of a threat or a asset to them than just having belief systems about UFOs and aliens or thinking that you know something other people don't. I mean, you're going to have to be an actual asset.

Like the nonterrestrials. They come down. This person is one . . . They consider it [him/her] one of their assets, and they control them. They don't control the people around them.

Other than . . . You know, they use similar fields to cause entire areas of neighborhoods – for people to go into a deep sleep or to change their brainwaves, put them in deep theta. They change their consciousness during the process of causing locomotion in your body.

David: Well, I want to throw something at you. I may have said this in the show. I may have not.

But one of the most profound experiences I had was getting a flat tire right near Washington, D.C., driving up to New York from Virginia Beach.

And I go to the tire store, and the guy that was working at the front desk had been in the CIA. And I figured this out pretty easily based on a few tells that he gave me.

I mentioned the two black ops UFO programs that Sergeant **Clifford** Stone has talked about on our show. It was already out there – Project Moon Dust and Project Blue Fly – and the guy's eyes get all wide.

He goes, “How did you know about that?”

And then we got talking. And I said, “Okay. Well, you guys are my problem.”

He said, “What do you mean?”

I said, “Well, I've been saying certain key words on the phone and then there's a click, and the lighted dial actually blinks off and on. And it's very clear that when I say certain words like 'extraterrestrial', that my phone is being recorded.”

And I said, “Are they singling me out?”

And he said, “Well, where do you live?”

I said, “Virginia Beach.”

He said, “How many people do you think are being surveilled that way in Virginia Beach?”

I said, "I don't know. Maybe 100?"

He said, "About 40,000, last time I was in there."

And I said, "Okay. This is what I thought. Are they just recording all this on a hard drive and not even really listening to it?"

He said, "Yes."

So is that really most of what's going on – the sort of Snowden bulk collection . . .

Corey: Right.

David: . . . without any real . . .

Corey: Haystack.

David: . . . personal action from intelligence operatives on people?

Corey: Right. And it's key words that cause something to rise up to be looked at closer.

David: So just to wrap up that one point. I have encountered incredible paranoia. And it seems as if the Cabal has put out a strong mind control to try to make people feel that if you learn anything about this information, that you now have intelligence operatives hunting you down, spying on you.

And I just don't really think most of the people would ever be even bothered with by the Cabal.

Corey: No.

David: Would you agree?

Corey: Right, right. That way, we kind of self-manage ourselves.

David: Right. Okay. The next question here comes from Larz, who says, "I love these Q&A episodes. I wish they came out more frequently." Okay, well here we go.

"I can't remember if these questions were ever asked and answered, so I'll ask anyways. I'd like to

know more about the daily lives of some of the ETs that **Corey** knows about. So here are my questions. I'm sorry if they sound silly.

“Number one . . . “ We're just going to go through these one at a time since he's got seven numbers.

“Number one: What do some of these ETs eat and drink? And do they eat as frequently as us humans, such as breakfast, lunch and dinner?”

Corey: A lot of these beings are very advanced, and their metabolism . . . they manage their metabolisms with their consciousness, and they don't have to consume food or nourishment that often.

Others have to receive nourishment very often. It depends on which beings we're talking about.

There are certain beings that do absorb nutrients through their skin; some that eat just like we do. Many eat just like we do.

So it just depends on the individual being's metabolism and where they're from – what planet they're from. Their eating habits are going to match that.

David: I think it was Henry Deacon who told me this, that there were certain aquatic ETs where they actually take algae, and they have these gills on their chest, and they just rub the algae into those gills. And that suffices as a meal for them. Have you ever heard of anything like that?

Corey: No, but I can see . . . Gills are similar to lungs. That's where the blood vessels go to collect oxygen. So more exposed blood vessels might be a easier way to get nutrition directly into the bloodstream.

David: And have you heard about any that would actually put their hands into some kind of an algae and be able to absorb from their hands?

Corey: Like Mork? [Sucking sound] Ha, ha.

David: Ha, ha.

Corey: No, I haven't.

David: Okay. When he says do they eat as frequently as we do, like the three-meal-a-day paradigm, you said some of them eat a lot more infrequently. Are there others, maybe the more human-looking types, that would be really similar to us, where they would have much more similar dietary patterns?

Corey: Right. And a lot of it is going to have to do with their circadian rhythms that were developed on their planet as they developed.

You know, if they have a planet that has a 28-hour day, their body and metabolism are going to match that rhythm. So they're going to be taking in nourishment to match that rhythm.

David: Along the same line of the question, I'm curious about dietary compatibility. In other words, could extraterrestrial beings come to Earth and be able to survive by eating food that you could get in a grocery store here?

Or are there divergences in the types of foods that they would eat?

Corey: Well, many of them would go into anaphylactic shock if they ate the things that we ate.

If they are going to eat from this planet, they're not going to be eating usually out of the same dish that we are.

David: Monosodium glutamate, additives, chemicals, preservatives, this kind of stuff – is that what you mean?

Corey: That, or it could be as simple as wheat, or barley, or something like that does not react with their system right.

They literally swell up and will have an anaphylactic shock.

David: Well, and I remember early along, when you were first getting brought up for the SSP Alliance, that they had these little balls of nutrition that you could have eaten, but the problem, they said, was that you'd have some kind of reaction to them.

Corey: No. I had to eat those.

David: Oh!

Corey: They're sort of like little peanut butter balls with flaxseed and all kinds of stuff in them. My wife has made something similar. I had to eat those because the type of printers or replicators that they had, the food would have wreaked havoc on my system.

David: Really?

Corey: Yeah.

David: Interesting. Okay. "Number two: Do they have 9:00 to 5:00 jobs? What type of jobs do they have?"

Now, this kind of gets into the interesting thing about "Star Trek", which is they go to Ten Forward. They don't pay for a drink. They just say that they want a drink. Or when they have a meal, they just have a materializer that makes it for them.

So do they have 9:00 to 5:00 jobs? Or do they have to earn money?

Corey: Well, they have to put in time in their duties, of course, . . .

David: Okay.

Corey: . . . but I don't know. A lot of times, if they're working with us, they'll work a 9:00 to 5:00 just because that's what we do.

David: Okay.

Corey: What they do in their free time after they punch out, I have no idea. It's just as divergent as the different beings that are out there. Some of them may go to their quarters and paint. Some of them may go and meditate.

Some of them may be more social and come together. It's hard to distinguish.

David: Would you say that maybe apart from drone-type clone beings, that most sentient life would alternate between periods of productivity and periods of leisure?

Corey: Right, right. Like going back to the circadian rhythm, the body's going to have to shut down to repair and process. If they're biological entities, they're going to have to go through some sort of cycle like we do.

David: And along those same lines, do all biological life forms, regardless of origin, end up having sleep cycles?

Corey: Yes. Yeah, they sleep. Some of them don't sleep for long periods of time, and then they will have a sleep cycle, like days or weeks.

David: Interesting. "Number three: Do they sleep?" I guess we just answered that.

"Number four: What's their educational system like, if any?"

Corey: Most of these beings are learning the way I hope that we learn in the future. This information is downloaded.

They have technological means of downloading data to their brains, and then having access to it. So they don't go and sit in a university environment, spend months learning one subject. It's downloaded, and they're able to apply it.

David: What would that entail as far as the biological birth and maturation process, where you have something starting out as a baby, and then going through childhood, adolescence, adulthood?

If you can just download information, what would be the point of all those years before adulthood then?

Corey: Well, they're downloading information throughout that process as they age – information that matches where they are in their process of growing. I mean, they're not going to . . .

David: If that would apply, you could have a much, much more intelligent being than us.

Corey: Absolutely.

David: Yeah.

Corey: Yes. But, you know, you're not going to download a library to an adolescent being. You're going to download the information. They physiologically have to be able to process it.

If you overload any consciousness with information, it's going to shut down.

David: “Number five: What do they do for fun? Do they play sports or watch TV and movies?”

Corey: Yeah. You know, depending, again, on the being. Some of them may spend time writing poetry, doing art. It's completely dependent on the type of being.

Most of the more human-type ones, they're very similar. The cultures are very similar. The languages usually come from the same root languages that have been departed to them, so it's not going to be that difficult for us to bridge languages with them.

We're going to have a lot more in common with these people than we're led to believe in sci-fi.

David: “Number six: Do they celebrate holidays or birthdays, or have any type of parties?”

Corey: I do know that they celebrate their life cycles, birthdays – at least, Mica's people do. I don't know . . . I'm sure that they probably have marked the calendar for the day that they finally threw the Reptilian rule out of their solar system. I would be surprised if they didn't.

David: Let's just get into a general question that that suddenly raised up for me, which is chronometrics.

If you have left your home planet, even though maybe your biological rhythms are naturally tethered to that home planet, I would think that if you went to another solar system, that you would then start to be governed by the physics of those rotating bodies.

Corey: Not so much governed, but you begin to have interference, kind of like temporal jet lag or something. They come here, and things just don't flow the same.

David: Well, and one of the things that you told me in the car that I think would be great to toss in right now was your understanding that in the SSP, you could be working from the '80s in the same base with a person who got pulled in all the way back in the 1950s.

Corey: Correct.

David: And that you're experiencing the same time there. So if that's true, as you just said it was, how did they even keep track of time at that point?

Corey: Well, you're going off of a standard time – some sort of Zulu standard time – for the day. They use military time. But if you take someone from the past and bring them to now, this is still the same solar system, the same circadian rhythm, the same cycles.

So that's not going to affect them as much as you may think. There is that zero time reference that occurs, but these different people that are working together, you're not allowed to discuss your past.

So it took a while to discover that they were going back in time and grabbing brilliant minds and technicians to bring them to the time frame I was in.

David: So do you have any way of knowing, if you were working in the late '80s, what percentage of the people that were there were pulled from, let's say, the 1950s? Or were they even going a lot earlier than that, like maybe 1800s, 1700s, and bringing people like that in as well?

Corey: No, I think it was in more of the modern industrial age that they've been pulling people.

David: So they'd have the right kind of knowledge base to be useful, perhaps?

Corey: Right. And the oddities that you would see would be the way they talked and the way they carried themselves.

From decade to decade, people talk and carry themselves significantly different.

David: So just to round out this list of questions here.

“Number seven: . . . “ - now we're getting a little racy - “Do they procreate like us humans?”

Corey: Yes. Yes. They seem to enjoy sex very much.

David: Okay.

Corey: They don't always – just like us – they don't always use sex just for procreation, but many of them, they will do what we're starting to do. They will put their genetics into a lab, have them genetically engineered, create this being in a more sterile environment than a womb. That's pretty prevalent.

But there are others that go through the complete birth cycle just like we do.

David: So the gender polarity would be a common element throughout extraterrestrial civilizations?

Corey: Yes. Yes. And, well, there are some species that have male, female and other sexes. It's very strange.

David: Well, I remember Jacob, the space program insider, telling me that his knowledge of the Reptilians was that people are thinking that they're looking at different Reptilian races, whereas he was saying that there are actually six genders that are on what he called a spectrum between fuller male and fuller female, and these areas in between.

And that those beings might appear to be sharply divergent-looking to us in terms of how they appear, . . .

Corey: Yeah, they look different.

David: . . . but that they're actually just on this gender spectrum. Have you ever encountered anything like that?

Corey: Not with the Reptilians, but yeah, with other species they do have more of mammalian-type species. They have a spectrum, I guess you would say, but it's not just male, female. It requires a group effort to procreate.

David: Hm. All right. Well, that's all the time we have for in this episode of taking your questions. I have a lot more here, but that will be for another time.

This is “[Cosmic Disclosure](#)”. I'm your host, [David Wilcock](#), bringing you your questions in a live debate here with **Corey Goode**, so you get to shape our discussion. And keep sending them in. We're going to keep using them. And I want to thank you for watching.

Cosmic Disclosure: Pushing the Limits of Disclosure with John Lear

Season 7, Episode 13

David Wilcock: All right, welcome back to “[Cosmic Disclosure](#)”. I'm your host, **David Wilcock**, and I'm here with **Corey Goode**, and in this episode we are bringing you none other than John Lear, the son of the inventor of the Learjet. And in this first segment, you're going to see him share his background with you.

So without further ado, I bring you John Lear.

* * * * *

JOHN'S STORY

John Lear: You know, my dad was Bill Lear, and he developed the Learjet. And I was really totally involved in aviation from the beginning. And I flew for different airlines all over the world.





And in 1985, I started getting interested in this UFO thing, which I didn't believe in.



There's a reunion here every once in a while, or every couple of years, here in Las Vegas of Southeast Asia pilots. And [i] talking to one of the guys, and he mentioned that he'd been stationed at Bentwaters.

And I said, "Oh, that's where that saucer supposedly landed."

And he said, "No, not supposedly, it did. I didn't see it, but I know the guys who did."

And so I said, "You mean this stuff is real?"

And that's what started me on all this. And then everything I'd run into got me a little bit further.

* * * * *

David: All right. In our next segment, we're going to get into some of the real meat of this, where we have a classic case in UFO literature.

I found out about this I think even before the Internet, because for me, prior to the age of the Internet, you would have to go to the bookstore, and you'd look for the new UFO books. And, of course, all that information is about a year out of date.

But one of the names that came up in those books was always **Bob** Lazar. Who is **Bob** Lazar? You're going to find out right now in this next segment. Let's take a look.

* * * * *

BEGINNINGS OF AN INSIDER

John Lear: His name was Gene Huff, the appraiser, and we were talking about UFOs.

And **Bob** Lazar was sitting there rolling his eyes, and he said, "You guys are nuts." He said, "I worked at Los Alamos. If there had been anything secret like that, I would have known."

And I've heard that so many times. It's incredibly ignorant people that say, "I would have known." Ha, ha, ha.

Anyway, during the rest of the summer, we gave **Bob** enough information that he could check with his friends that still worked at Los Alamos to find out that, well, yeah, something is going on because they do know a lot of stuff.



Los Alamos National Laboratory

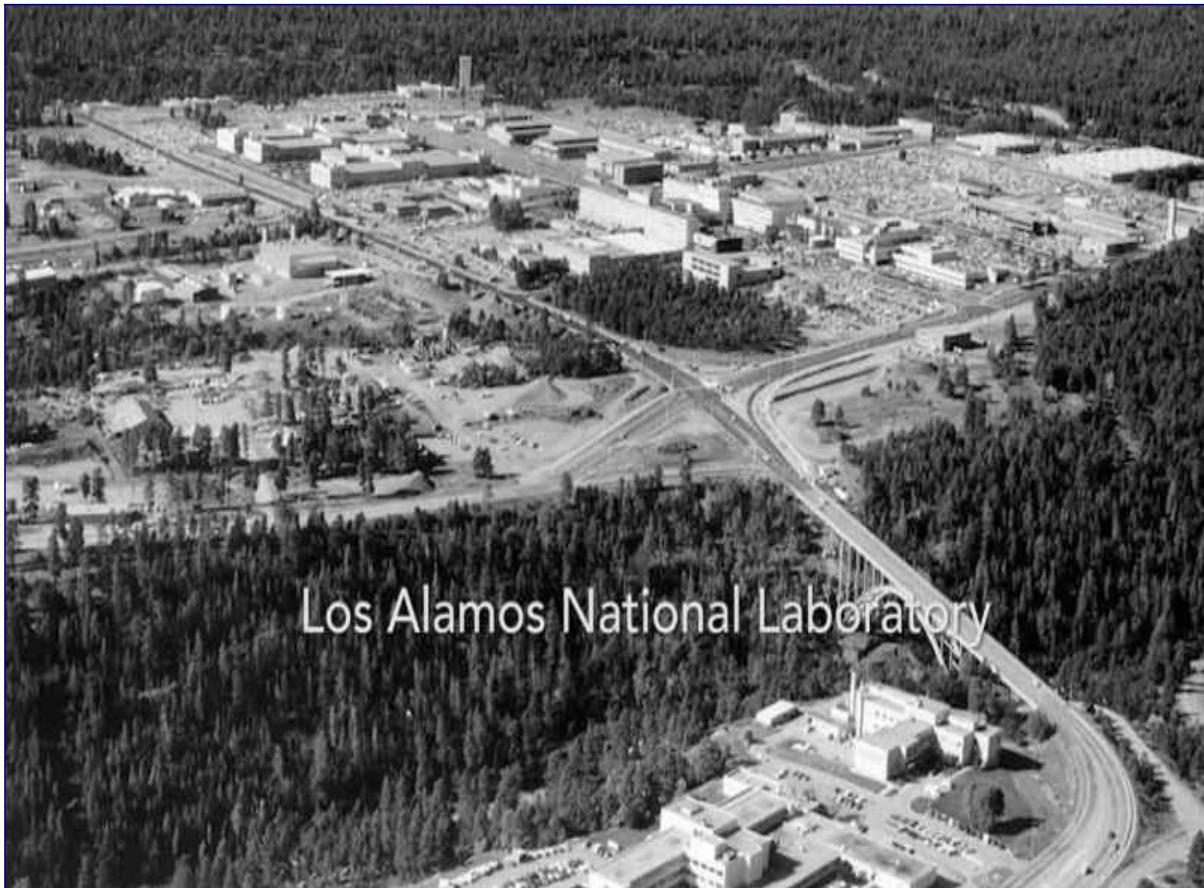



So he called up Dr. Teller, who he had met at Los Alamos, and said he wanted to re-enter the scientific field. And Teller said, “Do you want to work with me at Livermore here in California, or do you want to work in Nevada?”

Bob said, “I want to work at Area 51.”

Teller said, “Okay, let me get back with you.”

So this was in October of '88, and **Bob** then, over the next several weeks, got three interviews.

And he'd go down to EG&G, which is Edgerton, Germeshausen, and Grier, and there was a panel, and they interviewed him.

And he aced all the interviews. I mean, he was just right up with everything they wanted to know as far as scientific, and where he'd been, and what he'd studied in college and all that kind of stuff.

The second interview, their first question was, what's your relationship with John Lear? And what else do you do with John?



And so there was definitely interest there.

He used to come over in the evening, and we'd bullshit about what was going on. He said, “I saw a disc today.”

And I said, “What?”

“I saw a disc?”

I said, “Theirs or ours?”

He said, “Theirs.”

I said, “You went to Area 51?”

And he said, “Yeah.”

And I said, “Well, what are you doing here?” I said, “You know they followed you. Why don't you just work for a while, find out what's going on, and THEN talk about it?”

He said, “John, you've taken so much crap over the past few years.” He said, “I wanted to tell you it's true. I was in it. I touched it. It's not ours. It's from billions of light years away or wherever.”

And so that's how I met **Bob**. And he worked for the next few months.

And he'd tell us when the test flights were going to be, always on a Wednesday night. And we'd drive out there and take photos or videos and stuff.

One of the times, we got caught. And that's when the security guards stopped us within the test site.

We were still on BLM land, and it was legal, but they said, 'We can make it awful difficult for you if you stay here.’

So we left and got out on the highway, and that's when the Lincoln County sheriff stopped us.

“Get out of the car; hands up,” you know, all that stuff. They wanted to know two things: why are there four people in his car – or five people now – and there was only four when the security stopped you? And **Bob** had run out in the desert.

And the other thing was, “Where's the 9-millimeter?” Because **Bob** had said he got the 9-millimeter.

After about an hour, the sheriff – and I used to know his name real well – he said, “I don't know why I've been told this, but I've been told to let you guys go and not to say anything more.”

So we drove home, and early the next morning is when Dennis Mariana, the guy that **Bob** worked for, said, “**Bob**, don't go to the airplane. I'm going to pick you up. We're going to go up to Indian Springs.”

And Indian Springs is now Creech Air Force Base, and that's where the center for all test site security activities are.

And they took him there, took him out of the car with a gun in his ear and said, “Now, **Bob**, when we gave you this clearance, it didn't mean you were supposed to take all your friends and tell them about the flying saucers.” Ha, ha.

So at that time, **Bob**'s wife was having an affair with her flight instructor, which **Bob** didn't know about, but which they knew about, because they were listening to all his phones.

Everything was tapped – my house, **Bob**'s house, Gene's house, everything.

So they said, “When you get your life straightened out, you're welcome to come back.”

And **Bob** said the reason he never went back was the fact that the last two trips he made up to Area 51, he could remember getting on the 737 to go to Groom Lake and getting off, but nothing in between – no working, no what he did, none of that. So that bothered him.

He wanted to know what he was going to be working on, but their mind control is so far advanced now.

* * * * *

David: So, **Corey**, I wanted to start when he mentioned Edgarton, Germeshausen, and Grier, I think is the name of the EG&G defense contractor.

Corey: EG&G is one of these ICC companies that pops up all over the place.

David: Okay, so they are directly involved in reverse-engineering spacecraft of an advanced nature?

Corey: Yes, yes, working on different components of them.

David: Okay, now, he also mentioned Los Alamos, and some people might be tut-tutting on that one and saying, “Oh, that's just a nuclear facility.”

Are they really only messing around with nuclear weapons there, or is there something more?

Corey: No, there's always other programs being run underneath. I thought it was very interesting when he stated that **Bob** Lazar rolled his eyes and said, “If there's anything going on there, I would have know about it.”

I had an incident when I worked at the Federal Reserve. One of the guys that worked under me, out of the blue, stands up from his desk, turns to me, and – he was in the Air Force for like eight years – and he said, “I worked at all these places that they say UFOs are being flown at and reverse-engineered.”

And he said, “If this really existed, I would know about it.” And he was just looking at me.

And I was like, “Hmm.”

David: Right.

Corey: So that's a common thing. A lot of people would work all around this type of activity and, because of the compartmentalization, have no idea what's going on.

David: So if he said that after going back to Area 51 a couple times and having no memory of the work that he did there, and Lear is saying the mind control technology has gotten that good, is it possible that he also had experienced things at Los Alamos and had gotten blank slated on that as well?

Corey: He was absolutely blank slated. They had developed the blank slating process way earlier on astronauts, people involved in the space program.

And they were even using some of that in our first nuclear program. They were doing studies and doing

mind wipes on people chemically, all different types of methods.

So this is something that goes back to World War II.

David: Okay, now I want to get into **Bob** Lazar with you in some detail, because the original testimony was extremely fascinating. It shaped my whole career, and he really didn't touch on it at all, but he is the center of how that came into being.

So the first thing I want to throw at you is Element 115. **Bob** Lazar's testimony was that there was a super heavy, i.e., "transuranic element", that has an atomic weight of 115, and that that was the source of propulsion for the ship.

Now, at the time those books came out, no one had been able to get that heavy of an element to actually form, but Lazar said that once you get up past, I think it was 112 or 113, that all of a sudden it's not radioactive anymore – it becomes a stable element – but that it's very dense, and all you have to do is shoot protons at it, and it gives off tremendous amounts of energy, and that's how the ship is powered.

And there's a little sphere that the Element 115 is in. It's like a triangle of it. Then there's a tube that goes up, which he called a waveguide. And that this was the propulsion system of the ship.

So I'm wondering if any of that aspect of Lazar's testimony is anything you can comment on or clarify for us?

Corey: Was he saying that the propulsion and the power plant were one and the same?

David: Yes.

Corey: Okay, that would make sense for some of the more advanced extraterrestrial craft. But a lot of them were just using torsion field engines that were very similar to like the Glocke . . .

David: Okay.

Corey: . . . that had a separate power plant that would funnel high amounts of electricity to these torsion drives. And there would usually be three of them on most of these craft.

David: That's a very important part of what Lazar said as well, and I want to get to that in a minute.

Are you familiar with the idea that elements that are super heavy, i.e., with an atomic weight up around 115, could become stable again and non-radioactive, that you could actually hold them without dying?

Corey: The periodic table that was on the wall of various craft I was in when I was working with the scientists had way more than 112 or 114 or 118 elements on it.

David: Really?

Corey: [Shakes head to confirm this.]

David: All right, in this next segment, we're going to get into Lear and his father's aeronautics company's role in developing what we now think of as the Secret Space Program. This is very fascinating. Check it out.

* * * * *

THE SSP AND THE ISS

John Lear: I know that my father was the prime contractor for antigravity in 1952.

And I've got the papers on that. Unfortunately for him, he couldn't keep his mouth shut.

And he went down to Bogota in 1953 and started talking about UFOs. So as close as he was, they kicked him out of the program, but Lear, Incorporated, still kept with that antigrav stuff.

And I think that was totally complete by 1956, which means we had saucers then – you know, the whole enchilada by then.





Kwajalein is where all the secret stuff goes. All those launches are out in the South Pacific.





And Kwajalein Island, the Ronald Reagan, they launch probably every other day. There's probably 1,000 astronauts currently qualified that go up all the time.

So I was working ATS, Above Top Secret, or wherever it was, and we were talking about the discrepancies with the shuttle going up and taking 48 hours to get to the ISS, when it only took the Russians an hour.

And then the same thing, when they disengaged from the ISS, why did it take them over 48 hours to come back?

And, of course, what they were doing is . . . and what tipped me off is one of the videos they had when the shuttle got there, they opened the door, and it's only half full.

So what they were doing is taking as much stuff that they could for the astronauts that were doing all the secret stuff, and, of course, the things they had to have like fruit and perishables and stuff. And that had to go up and be unloaded.

And then the Russians would always launch the same day that the shuttle launched. And that stuff that they had in their rocket would be transferred to the shuttle, and when it came back down, the reason it took them two days is they were going to all the different space stations and dropping all the stuff off that the Russians had given.

Which brings me to the Cold War. I think that was all bullshit. There was never any Cold War. We've always been allied with the Russians.

* * * * *

David: So, first of all, **Corey**, John Lear is describing how his father with his aeronautics company apparently was put in charge of developing antigravity, or at least was one of the groups tasked with that.

Corey: Right.

David: And he was essentially excised from the antigravity research, even though his own company was still involved in it. And therefore, he believes that by 1956 that we actually had working flying saucers.

So let's just start with that little piece of data, and what does your experience and background suggest is the truth behind what he just said about this?

Corey: Well, the way you stated it was accurate, because they were . . . like **Tompkins** was doing. They were seeding this information to many different engineers and companies.

David: Like in these packages?

Corey: In these packages.

David: So could a package include blueprints of working antigravity prototype that then they'd have to reverse-engineer or something like that?

Corey: Yes. I mean, if you have five different groups with five different engineering teams, they all do not come up with the same concept.

Then you have five different or a few different concepts that are being worked on by different teams that are not cross-pollinating or polluting each other.

David: Now, the next thing that he got into was the times, you know, 1952 and 1956, where he thinks we had working prototypes. That sounds pretty close to some of what you said on the show.

Corey: It does, and it's right during the time that all of it was being developed.

David: Now, you'd mentioned before that the U.S. had gotten to a certain point in its own research, but it essentially hit a brick wall, and that, therefore, the Nazi breakaway faction overflights of Washington, D.C., in 1952 that kind of forced a truce to be made, that the U.S. wanted to do that in part because they needed intel from the Germans to be able to perfect their own antigravity. Is that still true?

Corey: Yes.

David: So what do you think was going on with Lear Aeronautics at this point? Was it only the German influence that then actually got them to perfect that technology by, as he said, 1956?

Corey: From far behind the scenes, this German breakaway group had infiltrated the military-industrial complex. Right after Paperclip, the infiltration had started.

And then after the overflights, and we made the agreement with the Nazi group, then, yes, they infiltrated like crazy after that.

David: Okay, the next thing that Lear talks about is this island that he said approximately 1,000 astronauts that would be working out of Kwajalein and doing space missions. That seems a lot less than some of the stuff that we've talked about.

Is it possible that this might be the MIC Secret Space Program that he's referring to now?

Corey: Yes, that's what it is.

David: So how do those numbers fit with what you've heard about the MIC program?

Corey: Not a whole lot of specifics on the numbers, but there were a number of islands that they were launching these multistage rockets, like old rockets.

David: Oh, wow.

Corey: And they were servicing . . . This is also how they created some of these space stations. Some of these MIC space stations are made out of different stages of rockets that, once they were used to leave orbit, they then ferried these pieces together, sort of welded them together in almost a circle, but more of like a flattened circle.

David: Like an octagon.

Corey: Like an octagon. And they would have like two or three layers of those, and in the middle, they have more of those types, like fuselage or stages of rockets, that are turned the other way.

And then the station spins, creating like a third gravity or something like that. And the shuttles would come and dock at the top of the spoke of the wheel.

David: Oh, so they did use the space shuttle?

Corey: Yeah, they used the space shuttle, conventional rockets, and later on when they started developing these larger, triangular shuttles. They called them shuttles. They had plenty of room to bring all of the food and . . . I mean, you're bringing stuff up, and you're bringing stuff back.

David: So what do you think . . . When he's talking about the space shuttle taking 40 hours to do the same work that the Russians do in one, I guess what you're now doing is you're confirming that that could be work that's being done, just like he said, going through MIC Secret Space Program bases like that.

Corey: Yeah, the space shuttles that we saw as a kid, they would dock with these secret space stations. They were helping build them in the beginning.

As we were developing the shuttle fleet, we see these black triangles. Those are what now service these various space stations, and they have manned satellites that have three to six people that rotate in and out.

David: What were those astronauts thinking they were doing? Was this like Star Wars and defending us against nuclear attacks from Russians, that sort of stuff?

Corey: It's the Star Wars program, SDI.

David: Okay.

Corey: They were all sworn to secrecy. All of the people that were able to make it into the astronaut program, I believe, as we've said before, they were Freemasons, people that they had in other projects in the military, and had proven that they could keep their mouth shut – not to mention that they also used blank slating on them quite a bit.

David: All right, we have another segment from Lear now in which he describes some of his own intel about this mysterious, enigmatic base out there in the middle of nowhere in the Southwest. Let's take a look.

* * * * *

WORKING WITH ETs

John Lear: I always tell this story about the Area 51. They hired a security guard when they were first cranking up, and he was supposed to sit at one of these hallway intersections.

One of the praying mantises comes walking down like this [John sways his shoulders from side to side], and the guard looks at him and has a heart attack and dies.

So what they did is they were more careful now. Over a period of three or four weeks, they flash different photos so that they didn't get so scared when one of these things walks down the hallway.

Joe Resnick was telling me he was working in a laboratory with a Reptilian. And he said they look just like us, and the only difference was they would close the inner eyelid every once in a while. And it would shock him every time they did that. They had two sets of eyelids.

* * * * *

David: All right, so let's pick up on the second part first. He's describing a Reptilian that he says looks just like us except for a nictitating membrane in the eye.

That doesn't exactly sound like the same type of Reptilians that you've been talking about. So why do you think that human-looking of a being would be called a Reptilian? What do you think was going on there?

Corey: There are a number of different types of Reptilian types of beings that we've talked about.

David: Sure.

Corey: But this could be even a hybrid for all we know, a human hybrid with a Reptilian.

David: Since you've personally seen a whole bunch of different types of ETs, did you see any that had a nictitating membrane like what he described?

Corey: There are a lot of different beings, especially the aquatics, that have a membrane that goes this way [**Corey** uses two fingers in front of his eye and moves them together and apart horizontally], and then they have an eyelid that goes this way [**Corey** positions his thumb and forefinger in front of his eye and moves them together and apart vertically].

David: So this kind of gets into the other thing, where he's talking about the mantis being. I guess there is a kind of a psychological shock that you're going to face when confronted with extraterrestrial life like this.

Corey: It's very rare that they're going to just put a person that's not acclimated to nonterrestrials in a situation with nonterrestrials.

In the beginning, they'll show pictures of dead nonterrestrials to them, show like a video clip. Then they'll get to see a dead one. And then they just slowly acclimate them to interacting with these nonterrestrials.

They did a lot of testing to see how people would take Disclosure, and often they would be military personnel that they would expose to nonterrestrials, and it was never a good reaction.

David: Are the mantis beings one of the most difficult types for us to see?

Corey: The Mantis and the Reptilians. There is a programmed visceral reaction. I don't care who you are, how advanced you think you are. When you first see these beings, your body, before your mind has a chance to process it, your body has some sort of a strange visceral reaction.

David: **Pete** also has described the sound of the sliding of the chitin as you are around one of these mantis beings, that even the sound of their bodies moving is like very disturbing and makes you feel tense, even if you don't see them.

Did you ever experience that?

Corey: Yeah. There are a number of beings that they would have kind of like an insectoid-type outer exoskeleton. And they would make noises or sound almost like fingernail kind of sounds, just strange kind of sounds, but it wasn't really that disturbing to me.

David: All right, so in this next clip, we're going to have some really contentious information about the idea of the nature of our Solar System.

Wait until you hear what **Corey** has to say, because even though this may seem hard to believe, there is some compelling insider testimony to back up what Lear is about to tell us. Let's take a look.

* * * * *

OUR STAR SYSTEM: REVISED

John Lear: Our star system with the Sun and allegedly the nine planets – there's really 40 planets. And many of them are hidden so that we can't see them for various reasons. And they want to keep that all secret, but there is so much going on between all of the 40 planets, their moons, their satellites.

Carl Sagan would say, “Yeah, well, there's probably aliens, but they're millions of years away.”

No, they aren't. They're right on Earth. Probably 25% of the population, Earth's population, is aliens. Of course, we're aliens, too, but . . .

* * * * *

David: So let's talk about this. Is it possible that there are these other planets out there?

Corey: Well, there are other planets and planetoids, some of them within and beyond the Kuiper Belt. They call them “Kuiper Belt objects”.

Some of them are being detected. Gravitational anomalies are being detected. And astronomers are beginning to say, “Yeah, there's something out there.”

But some of the planets, just like Pluto – I think Pluto is like 17 degrees off the ecliptic plane in its odd orbit . . .

David: Right. It's the only “planet” or planetoid that's offset in the official record.

Corey: Right. And we've got a pretty messy Solar System. There are other planets and planetoids that are in strange orbits off the ecliptic plane.

David: And he mentioned that they have satellites around them, meaning moons as well.

Corey: Yeah.

David: So is that true based on your experience?

Corey: Yes. I mean, they have a gravitational pull of their own. Some of them have many objects that are similar to moons that orbit them. But there are a large number of objects out there yet for conventional astronomy to discover.

David: You'd mentioned before that the SSP Alliance has a presence out in the Kuiper Belt. Are all of these different planets that we're now talking about, planets and satellites, being occupied in various ways? Is all the real estate essentially being used in some form or another?

Corey: They've all either been occupied in the past or are being occupied now, by both our space fleet, as well as nonterrestrials.

David: So the other thing that he discussed was the idea that 25% of the actual inhabitants of Earth – and this might not include anybody on the surface, would be my assumption – 25% could be extraterrestrial. How does that kind of a percentage estimate line up with what your intel would suggest about, let's say, Draco in Antarctica, Inner Earth civilizations, that kind of thing?

Corey: Well, to me it sounded like he was saying that they were living amongst us, just like us . . .

David: Hmm.

Corey: . . . 25% of the population. The amount of Draco and other beings that are below certain areas of our planet far exceeds that.

I have not heard any intel that stated that there were that many nonterrestrials living amongst us as us.

David: Right.

Corey: What he did say also is that we are all ETs, which is true. A lot of people talk, “I think I’m a hybrid.” Yeah, you are. We’re all hybrids. We’re all genetic experiments, and we have genetic stock from all over the cosmos.

David: All right, so now we have another segment for you in which Lear is going to describe his own intel surrounding the Moon.

It’s a little different than what I’ve heard and what **Corey** has heard, but rather than argue about it, we just want to try to find some common ground here. So let’s take a look.

* * * * *

THE MEN ON THE MOON

John Lear: The Moon is artificial. The two Russians that wrote the book about being a spacecraft, they were right on. It was.

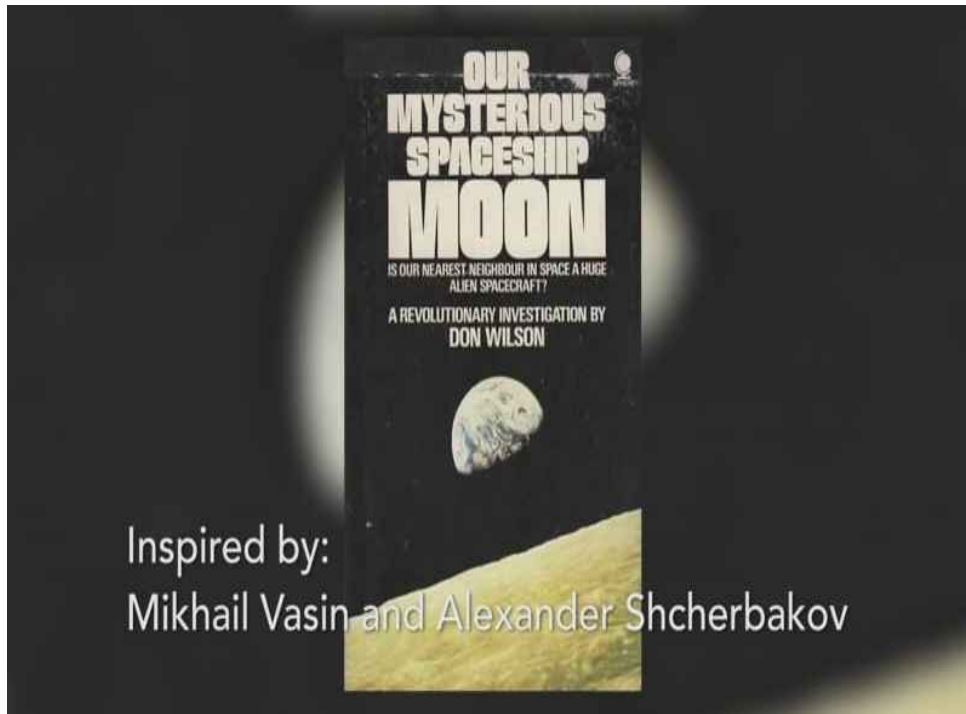

And there’s all kinds of stuff inside the Moon, and yeah, it’s artificial.

To monitor us about what's going on, they, you know, the humans that live there, are completely separate with the Greys that have the laboratories up there.

I estimate there's probably a quarter of a million people on the Moon right now. They're not humans like us, but humans from somewhere else.

And we used to think that the Greys would pick up one in 10. No, they pick up EVERYBODY. And they do it all the time, and they give them updated programs and things like that.

And fantastic laboratories they have up there. And we figure there's 7 billion people on Earth. That's a lot of trips.

And it's said that if they ever showed themselves without the cloaking, the sky would be black all day long with the ships going back and forth, taking all the different people back and forth and doing all the tests and stuff.

* * * * *

David: When Lear was describing the Moon being artificial, this, of course, is something you've discussed many times. So did you have any additional thoughts on that part of what he had to say regarding the idea that there could be, he believed, potentially a quarter million people living on the moon?

Seems like from some of the stuff we've been talking about, it might be a lot more than a quarter million.

Corey: It very likely is many times that.

David: Hm.

Corey: Yeah, the Moon is so developed out, especially on the inside, as he was saying.

David: There is a very strong claim being made here that everyone on Earth is being subject to these abductions by Greys. I'm not sure where he heard this from, but it doesn't seem like that lines up with

what I've heard from other insiders. And I'm curious about what your experience of that type of information would be.

Corey: Well, there are a large number of abductions that occur by other beings other than the Greys.

David: Sure.

Corey: You know, there's a grand experiment going on down here, and there are a large number of people that are being abducted. But it's not everyone. I mean, just the logistics of that.

Also, he mentioned that the skies would be full of craft if they were not cloaked. That is . . . it wouldn't be black, but we would see an amazing amount of air traffic if they weren't cloaked, both our own craft and theirs.

David: Are their highway type of things or conduits that the craft go in? It's not just totally scattered all over the sky like insects?

Corey: Right. They have flight corridors that they fly in. Even the Anshar, they have to fly within certain flight corridors.

But these craft are flying so fast, they could be flying all around, and you're not going to see them if they are uncloaked unless they stop or are going really slow.

They're moving way faster, you know, thousands of frames per second. But there is a lot of traffic in these corridors.

David: All right. Well, this has been a really fascinating journey into the testimony of John Lear, the son of the amazing aeronautics pioneer, Lear himself, the guy responsible for what we call the Learjet today.

This is "[Cosmic Disclosure](#)", and I hope you've enjoyed it. I know I have. I'm here with **Corey Goode**, and we'll see you next time here on Gaia. Thanks for watching.

Cosmic Disclosure: Secrets of the Apollo Missions with William Tompkins

Season 7, Episode 14

David Wilcock: All right, welcome back to “[Cosmic Disclosure](#)”. I'm your host, **David Wilcock**. I'm here with **Corey Goode**.

So what we're going to start out with here is a segment in which [**William**] **Tompkins** is exploring the very contentious Freemason connection to all of this. Let's take a look.

* * * * *

THE FREEMASON CONNECTION

William Tompkins: If you take me working in the secret think tank at Douglas, okay, the only two people that'd know that's even there at Douglas is the Vice President of Engineering and Dr. Klemperer.





Douglas Aircraft Company



Dr. Wolfgang Benjamin Klemperer

When we had meetings with Navy admirals there on the programs, or when we had meetings of other top officials, or when we were doing design review meetings of our own people, because we had a lot of people in that group, the subject would get to a point where there was no answer.

And then I would come up with an answer.

The Vice President of Engineering would always throw this in. He said, "Bill, you approach everything," meaning this subject and other stuff, "you look at it as if you're not from here at all."

I've had that stated to me hundreds of times by different people.

All I can say is, my dad was a 33-level Freemason. Okay? My uncle Harding was Chief Surgeon, Santa Monica Hospital – a lot of money, big house, spent every cent that he had digging through the insides of the pyramids trying to decipher the hieroglyphics. That's what he's trying to do. [He] has three daughters, my aunts.

We lived in that house for almost a year. And what are we doing?

There is a chair that he has next to the fireplace in that house. The chair is almost five-feet wide, wood chair, all covered with hieroglyphics.

And some people said that it was King Tut's chair. Well, that's a good thing to call it, but yeah, it came from one of the kings.

I don't know how he smuggled it out of the country, but he smuggled a whole lot of stuff out of that country. And he disseminated it to top research people in the United States.

So once again, who was Uncle Harding? A 33-level Freemason, okay?

And all I'm saying is there's a whole lot of stuff that we're not involved in, we don't understand.

* * * * *

David: So, **Corey**, the first thing that he said is that everybody there acted as if he wasn't from here. These answers that he would come up with for seemingly ponderous questions no one could answer were suggesting, it appears from what he's saying, and if you read his book, that he had some sort of telepathic knowledge or some sort of deeper wisdom.

So regarding this concept of extraterrestrial lineage or extraterrestrial consciousness, is that possible, and do you think that that could be what's going on with **Tompkins**?

Corey Goode: It could be a number of things. It could be that he incarnated here from another extraterrestrial soul group, possibly these Nordics that he's talking about.

David: Uh hm.

Corey: Or he is in conscious and unconscious telepathic communication with them.

David: Which we does describe in his book . . .

Corey: Right.

David: . . . conscious communication with Nordics.

Corey: And I've experienced that myself.

David: So when he described this question of Uncle Harding being a 33rd degree Mason and also the head of the Santa Monica Hospital, taking all of his excess money and plundering out artifacts from the pyramids, some people might find that hard to believe.

They would think that there's very tight government regulations on those artifacts and where they go. Is that not true?

Corey: Not back then.

David: Okay.

Corey: It was very common for people to “do archaeology”. They called it archaeology, but it was basically just tearing up archaeological sites, looting it for trinkets that they would sell or take home to sell to a museum.

David: So you think that there actually could be artifacts as amazing as a five-foot wide chair covered with hieroglyphics just sitting in somebody's house?

Corey: Oh, absolutely, yes. There are large private collections of very important artifacts.

David: Why do you think Freemasons would be interested in this stuff?

Corey: As you know, or many may not know, everyone, in order to be involved in the civilian space program, were required to be Masons.

Masons are “keepers of knowledge”, and if they're getting these ancient wisdom teachings through their various teachings and all these things they have to memorize, what they have to memorize is just crazy.

If you've proven yourself that you're able to keep these tenets and secrets, then you're trusted with many more.

David: Right.

Corey: And you're already a part of an organization that is being managed.

David: And in case somebody doesn't know, what are the penalties for spilling Masonic secrets if you become an initiate?

Corey: Death.

David: Yeah, so it's a very intense rite of passage to be able to get somebody's confidentiality and a sense that you can trust them with secrecy.

Corey: They take it very seriously.

David: So why do you think he mentioned his father and this uncle being 33rd degree Masons when he discussed the idea that he might be an extraterrestrial soul?

Corey: A lot of these societies trace back their lineage to nonterrestrials that came to this planet thousands of years ago. And that, too, is very important to them, being able to trace this lineage.

While tracing the lineage, they're also tracing the history of the lineage. And all of this information,

well, some of this information is going to be available to certain Masons.

And apparently his uncle had heard enough of this information that he felt compelled to spend his own fortune to try to answer some of the questions for himself.

David: All right, now in this next segment, what we're going to have for you is a further discussion of Freemasonry as it applies to something very interesting that you might not have thought of before. Let's take a look.

* * * * *

REWRITING THE APOLLO MISSION

William Tompkins: So now I am Engineering Section Chief at Douglas on the Apollo program, and I had 173 engineers and designers and scientists, actually 11 PhDs.

Product Planning Committee Members
Charles W. Hutton, A-110

DATE: April 10, 1963

COMMITTEE FILE NO. 111-1

FILE NO. 111-1

MEMBERS: H. E. Pitcher, A. V. Smith, H. M. Wales, W. M. Tompkins

ATTENDEES: C. R. Able VP, H. E. Pitcher VP, N. T. Weller, R. L. Johnson VP, A. V. Smith, P. Horton VP, W. M. Tompkins, C. W. Hutton VP, H. M. Wales

THE MEETING WAS CALLED TO DISCUSS A POSSIBLE DOUGLAS ROLE AS MANAGER ON NASA SATURN PROGRAMS.

Alex Smith, W. M. Tompkins, and H. E. Pitcher presented outline of proposed plans for a NASA Facilities Management Program, showing proposed launch site locations and checkout building plans. Certain statements by, and discussions held with, various NASA officials indicate that this effort is of such magnitude that it will be necessary to place a contract with industry for all or portions of, this program similar to the Pan American contract for management of Convair. Validity of the requirement was verified by Mr. Tompkins who is a member of the L. O. C. Facilities Working Group headed by Dr. Debus, Director of L. O. C. for NASA.

And I make the suggestion. These guys take it and run with it. Okay? Best group of engineers on the planet, top guys.

And we put together a whole new NASA program for the Moon. Threw out everything that NASA had done, came up with a whole new one. Okay?

I submit it to the heads of engineering. They submit it to marketing, and marketing talks to the manufacturing people, and they try to fire me. Okay? Because manufacturing wants to manufacture. They don't want to do this engineering stuff at all. Okay?

I don't get fired. I get authorized to go ahead and do this. But marketing, . . . they wouldn't do it. So the Vice President of Engineering said, "Secretly, we're going to do this ourselves."

So I put the stuff together. I have a six-foot by six-foot model of the new NASA mission command center – looks just like a big theater with step-down seating, screens on the wall.



So I put it on to a brand-new DC-7 and all my documentation, and I fly down to the secret Redstone Arsenal, secret space station, where all the Germans and where NASA is.



And I rent a truck. And I'm in a three-piece business suit. I rent this truck, and it's got all these gears that I've never run.

And I drive this thing with a box in it into this secret area. Okay?

But what's interesting is that my secretary writes me a letter which will get me to the top man in Redstone Arsenal, but she tells me I'm not going to need it.

And as I'm driving up, she tells me telepathically, "Don't worry, Billy, the gates are going to open."

So I'm driving in, and these great big gates open, and I drive right on in, past an enormous area on the side with dozens and dozens of trucks and cars and automobiles and equipment, where everybody has to go through security to check everything you've got in that truck, get permission to take it in, and all that stuff.

So I drive right through the gate. The gate opens.

I drive in that thing and start looking for von Braun's office myself. I go through the traffic of the base. Okay.

I get to the base, finally the tower. The four security guards of the building come down. They put their rifles next to the building door.

They're coming down the stairway with a great big enormous dolly. This dolly has four wheels. They all carry it down the steps. They roll it over to my truck. They take the bars and the side bars, wooden bars, off the side of the truck. They take my model and move it over to a dolly.

Where did the dolly come from? Why was the dolly there?

They push the model in on the big dolly, back into a bunch of offices, down a hallway. The elevator door – quite large door, elevator – opens up with three other elevators on the side of the center one. The doors open up. They push this in.

I walk in with my satchel full of my data. We go up to the top floor. The doors open.

They, not saying a word, push this dolly into the lobby area. Those doors opened up.

We went into the first big office area with all of von Braun's people on this side and Dr. Debus people on that side.



The doors into this great big conference room open up. They park the dolly. They open up the box.

They pick this model up that's got . . . it's covered with this soft blue cloth. They set it on the blue cloth in the conference room.

Dr. Debus' secretary and Dr. von Braun's secretary come over to me.

The four guards take this dolly. They roll it back out. They click their heels, and they salute, and it goes downstairs.

Now, remember, I haven't said a word to anybody. I came on board this facility without any piece of paper. I've come in. I haven't talked to anybody. And both of them already know that I'm here now.

So Debus' secretary said that Dr. Debus will be here in just a moment, and Dr. von Braun will be here

too.

Debus came out of his conference room, and he introduced himself to me. And von Braun came out of the other conference room, and he introduced himself to me too.

So now they've got this great big blue thing in the middle of their shiny conference room table.

I said, "I'm **William Tompkins**. I come from Douglas, and I have a proposal that we'd like to present to you on some changes we feel are necessary for the Apollo to get to the Moon."

Nobody stops me. Several of von Braun's people come in and sit behind him on his table. Debus' people sit with him. Both of the secretaries sit down, and I start talking.

And at the right point, I pull this cloth off, and I show them what you and everybody else on the planet has seen, which is Complex 39's launch control system, where you've seen Dr. von Braun sitting up at the top and all the engineers and everybody watching the stuff on the screen.







So I have a model of this, and what took place was they both heard my pitch. It took me about 40 minutes on the pitch, and von Braun shook my hand and said, “We need to get together.”

And Debus shook my hand, put his arms around me, and he took me to every top guy in NASA there, introduced me as some sort of genius.

* * * * *

David: So once again here, what we are seeing is an extremely valuable historical document showing us how one of the most highly regarded and beloved images associated with the Apollo missions and our trips to the Moon, what he's calling Complex 39, what most people would just think of as Mission Control, was actually something that he himself designed, going against the will of the manufacturing crew, who just wanted to manufacture.

So why do you think he said that he would get such a backlash and that manufacturing just wants to manufacture?

Like what were you hearing when he's describing this ping pong juxtaposition between engineering and manufacturing?

Corey: A lot of these engineers, they don't like to be pulled off of what they were doing or working on for a long period of time and be put on a special project. A lot of them will resent it.

They are now reporting to people that they didn't report to out of their core group. They would just rather have things status quo. And that's the way engineers are.

You don't want to shake things up with them too much, or it will affect their work.

David: So the people that were in what he's calling “manufacturing” were engineers, but they were specialists in a particular category.

Corey: Right, you'll have engineers, and then you have technicians, who are basically engineers and just as smart as the engineers that are actually putting into practice what the engineers have designed.

David: Is it possible that there are certain cases in a highly secure military facility where somebody would get clearance to be able to bypass the normal security checkpoints as he's describing?

Corey: In very rare circumstances. Back in the '40s, similar things happened with the delivery of the nuclear . . . of transport of the nuclear weapons.

They would go in through a side gate or right through the front gate. The sentries would be told ahead of time, “This vehicle's coming at approximately this time. Wave them through.”

David: Now, last time we saw a segment in which he was describing the actual development of the German V-2 rockets. I mean, he didn't call them that at the time, but that there was a nuclear-type of capability is what he was implying that they were working on that, and that those missiles were then directly implemented into the development of the Apollo program, that same German technology – von Braun, of course, being German.

Corey: Right. These aren't the V-2s. These were actual multistage ICBMs that they were already developing . . .

David: Oh, really?

Corey: . . . on the board developing at the time. So von Braun came in with that knowledge. So making multiple-stage rockets was something that he already had put a lot of time and effort into engineering.

David: All right, so the next segment that we have for you is another very interesting one in which this really amazing man is describing that there was a lot more going on with the Apollo missions than just landing on a dead old dry piece of rocks with nothing to see. Let's take a look.

* * * * *

ONE SMALL STEP

William Tompkins: First phase was to get up there, pick up the rocks, take the pictures and get back, okay?



So we get there. We got all these vehicles all around the rim, and one of those nearly push us out of orbit to even get in there halfway to the Moon. It came right up next to us. Okay?

And so the public didn't hear the conversation, "The damn thing's almost going to hit us!"

Communication, Mission Control, right out of the vehicle. And so you get there, but you've spun around several times. You've taken all your pictures of all the stuff that's already there. You know where you want to be.

And then, as you make your first run, here's all these vehicles coming in – great big massive things.

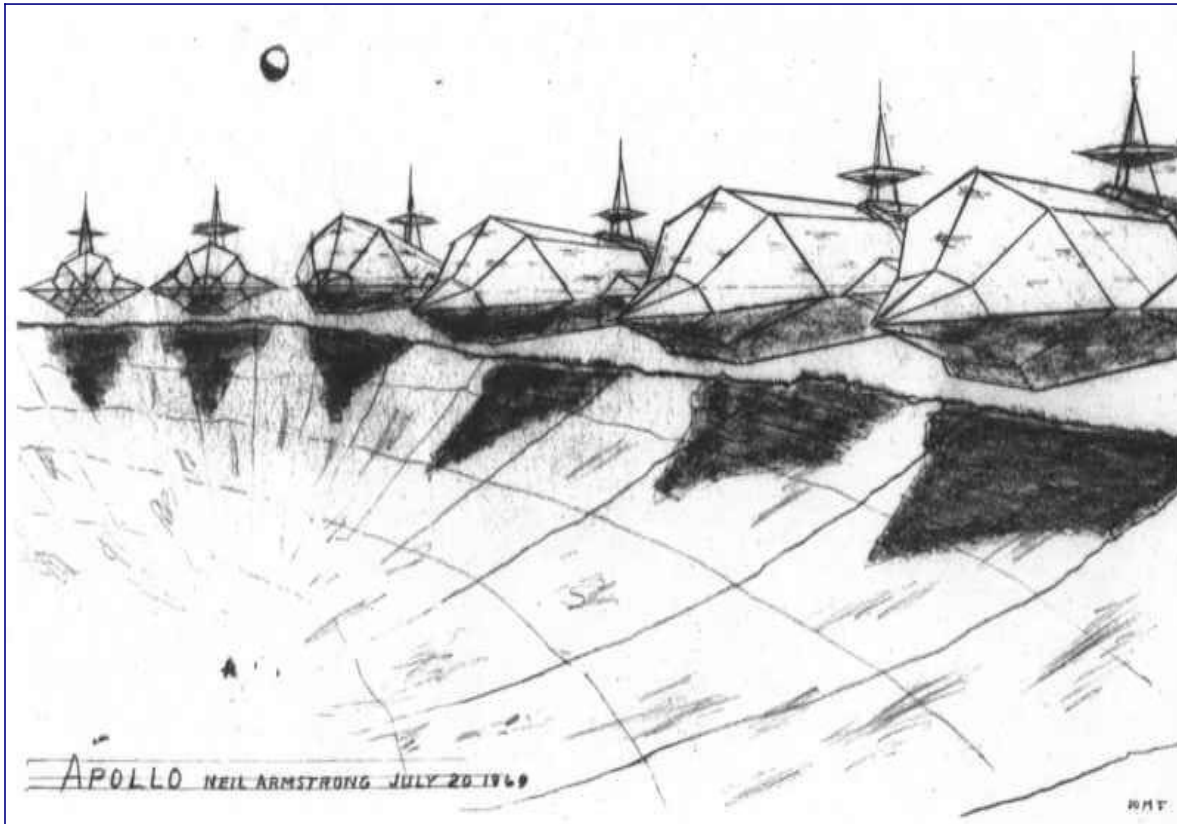

And they go park around the rim of where you got to land! Holy cats!

So you land. You do your . . . We have to do our thing.

And then the guy says, "Okay, go ahead and pick up some more rocks. And I know you have a problem, so do two or three of your additional missions, and don't come back. Period."

David: So what do you think was going on there? I mean, **Tompkins** is presenting it from the eyewitness perspective. What's the insider perspective on this story that we just heard here?

Corey: The Apollo crew landed in an area that was sensitive to the Reptilians. They came out and surrounded the rim of the . . .

David: “They” the Reptilians came out?

Corey: The Reptilians came out in a number of large ships to intimidate.

David: I see.

Corey: And when the astronauts gathered the rocks, did a few of their experiments, and then went to leave orbit, one of these vessels escorted them.

David: So when **Tompkins** is saying, “The guy told us not to come back. Just get a few samples and go”, who do you think he means by “the guy”?

Is he talking about Mission Control, or is he talking about extraterrestrials, or what do you think he was driving at?

Corey: Apparently, one of these nonterrestrials, either a Reptilian or not, told them that they needed to leave and not come back. It could very well have been even a Nordic telling them, “Hey, you need to get out of there. Do what you need to do, and then don't come back.”

David: Some people watching this who are not more familiar with this type of disclosure could be experiencing what in psychology we'd call cognitive dissonance about the idea that something this big could have happened on the Apollo landing, where Neil Armstrong seemed pretty happy when he's saying “One small step for man. One giant leap for mankind.”

You know, we have film. We have photos of what's going on down there.

Corey: He probably was quite happy at that time. That was . . . And then later on, all of a sudden you've got these intimidating-looking craft that are ginormous surrounding the crater you're in. That's probably going to change your tone a little bit.

David: A lot of skeptics would assume that this is completely ridiculous – the idea that, “Oh, well, of course, the astronauts would have talked. Of course, we would have known about this. Of course, they would have captured it on film, or somebody would have squealed, or something would have leaked out.”

How do you answer that?

Corey: That's what the blank slating process is for. I've heard many a story of astronauts that will have no memory of their mission, or very little memory of their missions.

So a lot of them, they're having their memories manipulated.

David: Bob Masters, who was the husband of Jean Houston, the famous female celebrity, actually tried to hypnotize Edgar Mitchell after his Moon missions and spent 40 hours trying to hypnotize Edgar Mitchell.

And Edgar Mitchell was never able to remember a single thing that happened to him when he was on the lunar surface.

Is that what might have happened to Edgar Mitchell?

Corey: It sounds like that might exactly be what happened to him.

David: Skeptics might say, “Come on, man, that there was live video feed coming in from the landing on the Moon.” How could these ships have not been seen?

Corey: You have at least a two-minute delay, and then you also have the medical channel that they would go to to discuss things that were not for the ears of the public.

David: So, in other words, if we have Germans who were brought over here to build NASA that have oaths of secrecy that they're keeping and maintaining, they would have designed this from the beginning knowing that there was going to be things they didn't want us to see and make absolutely sure that we only saw the version of reality that they wanted us to get. Would you agree with that?

Corey: I would agree.

David: All right, what we're going to see now in this next segment is another very interesting historical document suggesting that **Tompkins** may have had a pivotal role in the development of the very secret space program business model that **Corey** actually was involved with as a functional profit-making enterprise in our Solar System. Let's take a look.

* * * * *

INTERPLANETARY CORPORATE CONGLOMERATE

William Tompkins: I get fired from Douglas for going to Apollo and von Braun and changing the program. I get fired on a Friday.

And Saturday night, my secretary calls me and tells me, “Okay, Billy, I've talked to Dr. Debus, and he wants you to talk to Dr. so-and-so at the corporate office of North American over at LAX.”

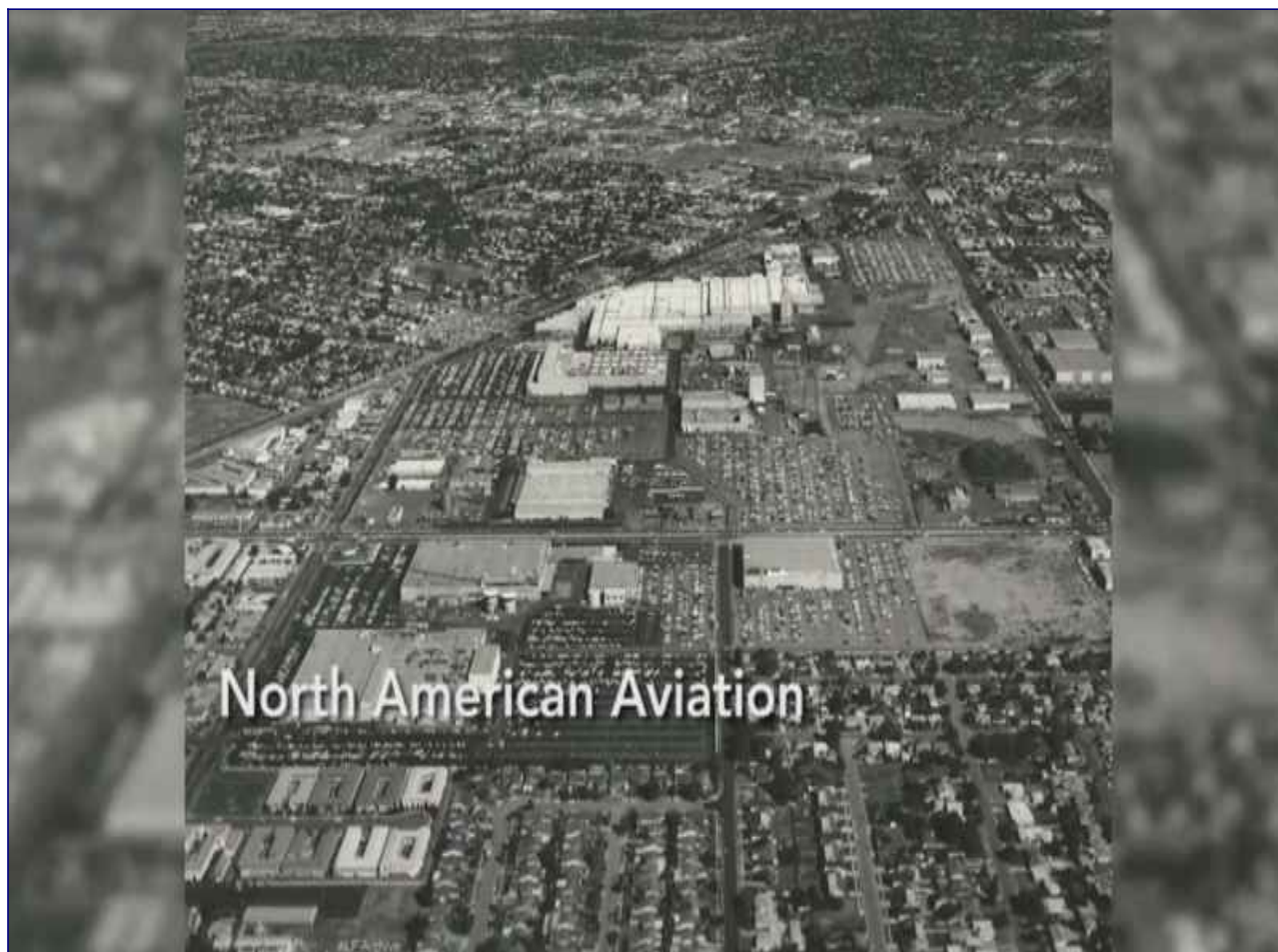

So I call Dr. Debus, and he has made arrangement for me to take a position in the corporate office of North American in advanced space programs, vehicles, and over propulsion system programs at Rocketdyne.

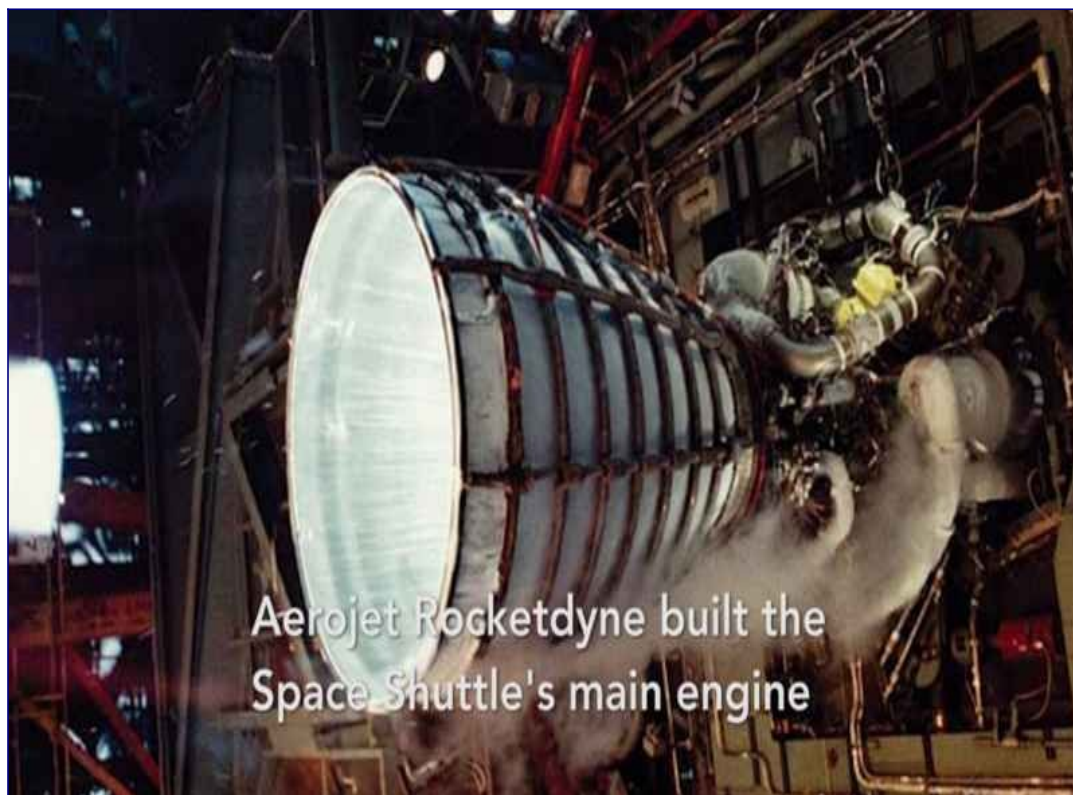

Anyway, they're the ones that build these great big space shuttles, and everybody see them. So now I'm an adviser to these guys. I bring my stuff with me, a lot of it, from Douglas to my offices in North American.

I put together a rough of a plan how to design and build commercial spaceships which could go out into the Solar System and set up facilities on local solar system planets to learn how to mine some particular mineral here on the planets as a learning program to go out into the galaxy as business and commercial and operate from another star's planet with large corporations, all private, nonmilitary, to not just go look for mining, but virtually any subject we can come up with – commercial, interface, commercial.

But they had far more important things to do, and so we didn't get involved . . . I didn't get involved with developing that. But other people took it over later on, and they implemented the program.

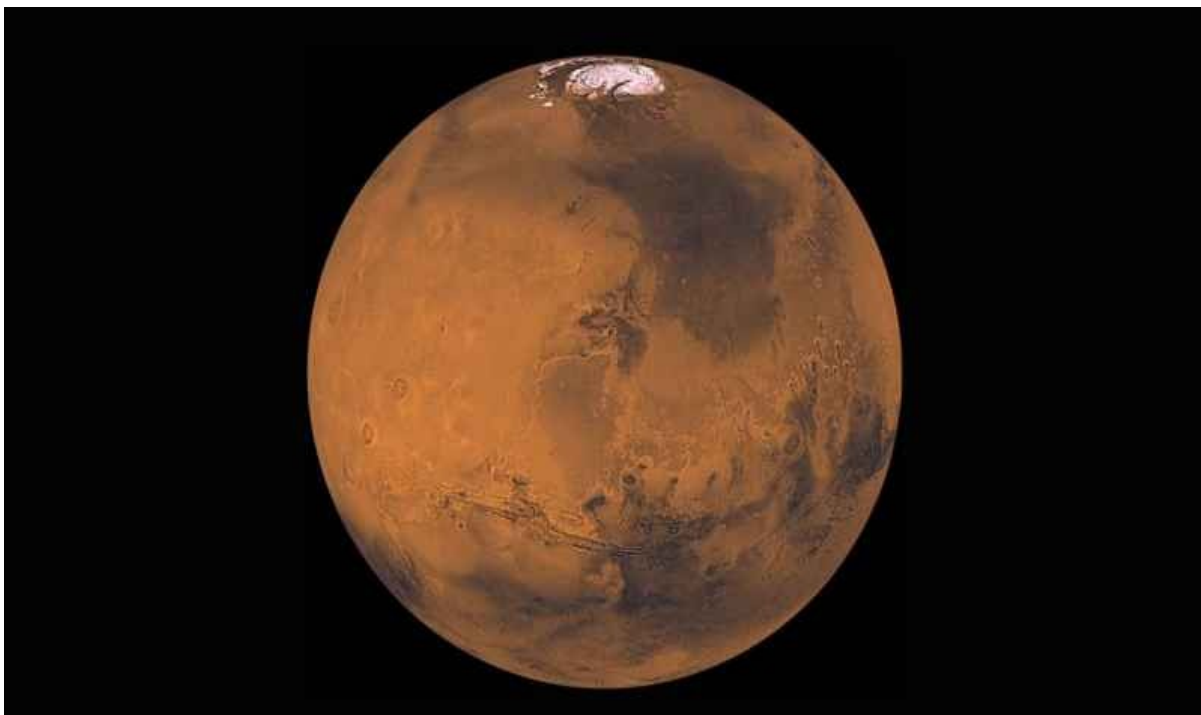

2003, they had their facilities run in two different locations, one on Mars and one on another planet off of the second star, closest star.

They're mining now. They're mining, and they're commercially operating – North American, a company here in Los Angeles, okay, still the same company as it was way back doing rocket engines and space shuttles and all this other stuff.

So they took that concept, used it, used it for commercial operations, which is what we wanted to do way back when we were trying to start this. Okay?

But they took the time. They brought the people in, and they did the commercial stuff, and they're doing it now. They're successfully operating.

What I'm trying to say is there's maybe as many as 25, 28 companies here on this planet that are operating commercial operations out in the galaxy.

* * * * *

David: All right, so, **Corey**, what we're seeing here is really fascinating, the idea that **Tompkins** may have actually been the first person, at least in the West – we don't know about the German side – to have considered the possibility of using this not just as a Reptilian invasion force, but to develop a commercial mining industry and production industry out in space.

Corey: Well, yes, the Germans were already exploiting the military aspect of it to fly alongside the Draco. The U.S. Navy and parts of the U.S. government were developing a counterbalance of power against this German fleet that was being developed to fight alongside the Draco.

And basically, we were going to be doing the same thing with these Nordics, fighting alongside them, fighting the Draco. So that . . .

David: So do you think it's possible that his historic role could be confirmed by this, that perhaps up until the time that he had that idea, that no one had actually been thinking about this as a potential business that money could be earned from, or profit in some other form?

Corey: The moment they develop the technologies, they start various think tanks to come up with ways to exploit it for commercial and military purposes. So he was probably just one think tank.

David: And he described that there were 23 to 28 industries, I believe is what he said.

Corey: Companies.

David: Companies here on Earth that were all involved in this industrial manufacturing in our Solar System and outside our Solar System. How does that number jive with what you've heard?

Corey: It's much larger than that, but that could be probably the core companies that started what we are calling the Interplanetary Corporate Conglomerate. They could have been the first businesses to begin this program.

David: Another thing that I feel we need to cover here is he mentioned in 2003 that there was a mining facility on Mars and another one in one of the two closest stars to our solar system.

That is certainly a lot smaller than what we've talked about with you on the show before, so . . .

Corey: Yes, that is much smaller in scale compared to what we're actually doing out there. We're mining the Asteroid Belt. We're mining various planets for minerals, and we have a number of mining operations on Mars.

David: What's your knowledge of how many sites there are where commercial adaptations are taking place outside our Solar System?

Corey: There are a number of them. They're usually Draco-controlled worlds that they've allowed us mining rights, I guess you would say.

We've gone into other star systems in our local star cluster to look for minerals, and when we got there, we were turned away by the inhabitants.

David: Probably violently, I would assume.

Corey: Well, you know, we don't have a real good reputation running around with the Reptilians, around the cosmos, causing problems.

David: Right. All right, well this has been another fascinating glimpse through the pages of history.

William Tompkins, a true American hero, coming from the very highest levels of the World War II military-industrial complex secret space program apparatus in its origin.

And now we have the opportunity to connect the dots. And I hope that you're seeing, just like I am, how beautifully all of these threads line up, and that we are, in fact, talking about something that is true, and in time will become public knowledge and will dramatically transform every aspect of life on Earth and in our galaxy as we know it.

I'm [David Wilcock](#) here with **Corey Goode** and our special guest, **William Tompkins**. This is "[Cosmic Disclosure](#)" on Gaia, and I thank you for watching.

[Cosmic Disclosure: Viewer Questions Part 7](#)

Season 7, Episode 15

David Wilcock: Welcome to "[Cosmic Disclosure](#)". I'm your host, [David Wilcock](#). I'm here with **Corey Goode**, our insider's insider. How are you doing, **Corey**?

Corey Goode: Doing well, thank you.

David: Welcome back to the show. All right, first question is from Schmitz_K, and it is as follows:

"Love the viewer questions. I also have a question of my own. Do the SSP vessels produce gravity or are they a zero G environment? And is gravity severely reduced in the LOC?"

Was there gravity when you were on the ship?

Corey: Yes. They have plates on the floor that create a gravitational field, but also within the bubble of the torsion field, it creates an environment to where they can control the gravity better for some reason.

Now, the lower level SSPs, they don't have all of the artificial gravity. So you'll see the monkey bars on the ceiling that you use, you know, for getting around.

David: Oh. If we go back to the German Bell craft, did they have zero G environment when they were flying in those?

Corey: Yes.

David: They did?

Corey: Yeah.

David: The second half of the question was about the LOC. Is there severely reduced gravity in the LOC? I guess they're thinking about the Moon's gravity being less than ours and how the astronauts supposedly bouncing around.

Corey: Right. On the LOC, there was one G of gravity.

David: Oh.

Corey: Now, there are some of the other surface bases that they have that we haven't talked about so much where there is no gravity.

David: Oh, no gravity?

Corey: No gravity, except for, well, the Moon's natural gravity.

David: Right, okay.

Corey: Right.

David: Okay. We have a question from Marcus O., and it is:

“I would like to hear **Corey** going into more about the work he's done on himself, also more on his high vibratory diet and what work exactly we could be doing on ourselves. I understand that he doesn't want to come across as a leader, and that we shouldn't be 'following him', but some of us would like advice and extra information.

“For people who are trying, i.e. with diet and meditation, what would be some good suggestions for both? It would be nice to hear more about the work we should be doing for this conscious renaissance.”

Corey: Well, there is a component to this situation that I'm having my vibratory state augmented just by being in the presence of some of these higher vibratory beings.

David: [**David** shakes his head in agreement.]

Corey: And I'm getting personal one-on-one advice from them, and it's very uncomfortable advice. About 80% of my communications with them involve them shining lights where I've refused to shine lights.

David: So for somebody who isn't having beings show up in the room with them and giving them a higher vibration just by being in their presence, what are some of the practical steps of people actually achieving that forgiveness?

Corey: Less looking out here for solutions and a lot of introspection. We all have the traumas in life that we think we've put behind us. We don't have to deal with them anymore.

Well, it's time that we start, you know, digging them up, holding them up to the light, and, you know, doing the hard work. This has been very difficult.

A lot of people are like, you know, "You're getting this one-on-one contact. How lucky are you."

It's very, very difficult. It's demoralizing at times.

My ego has been so, I guess, massaged in – not in a way to make it bigger but to make me more humble.

Anytime you begin to think highly of yourself, they come, "Wait a minute. Look at this, this and this."

And you know, it puts you back in your place and puts you back on the path.

David: So the question also revolved around dietary issues, and there's another one that we have in here, I think, that is going to cover that as well.

So he was specifically saying he's already trying to do a healthy diet, but what are some of the suggestions that might be of assistance?

Corey: Well, that is definitely a process as well. One of the things I was being told, especially by Tear-Eir, was that I was not practicing what I was preaching.

I was talking about high vibration diets, going home and eating corn dogs and all these nitrates, . . .

David: Right.

Corey: . . . and it was wreaking havoc on my body. I mean, you can see from the first season, you know, how unhealthy I looked.

David: It's amazing, the transformation of how much you've changed. And it really did seem like once you had that contact with Ka'Aree, and you touched her hands, and then you had this mind-meld that something really triggered in you at that point.

Corey: You know, it's a difficult path. Each person's path is different.

I mean, you have to deal with your old traumas. You have to deal with your current behavior that is destructive.

If you don't do that, no matter how spiritually advanced you think you are, you're just deluding yourself.

You have to work and take care of all these little earthly issues that are acting like a parachute to hold you back.

David: So since the question also related to diet, I want to bring up the subject of the weapons system, something that several insiders have talked to me about, the idea that the Cabal itself actually has put in certain ingredients in food that is intended to reduce lifespan, decrease happiness, increase weight, all this kind of stuff.

So are you personally aware of the idea that the food system that we have is being weaponized in certain ways?

Corey: Yeah, our entire environment has been weaponized against us. That's why we've got to mitigate all of those weapons as much as we can.

And in my case, I ended up moving to a vegetarian diet. I was pretty much forced to by getting food poisoning.

David: Right.

Corey: So I was real slow to start practicing what I was preaching.

David: Okay, so the next question is from Sedona Visionary, and it says:

“**Corey** has mentioned more than once that he uses a technique for releasing negative entities from his energy field. I would really like to know the how-tos. I know he said he does it using the name of Jesus Christ, but there must be a little more to it than that that would be helpful for people watching this show to use.”

Corey: Once I realized that I did have entity attachments, I went back, of course, to my background and how I was raised, and I called on the name of Jesus and it worked. They just fled the scene of the crime.

David: Right.

Corey: Later on, I was reinfected with entities by Mara, one of the Inner Earth people that had visited me without my permission.

David: The negative being, in this case.

Corey: Right. In that case, Ka'Aree removed them with some sort of tone from a crystal, and they fled exactly in the same way.





I guess the power that I assigned to the name of Jesus gave it some sort of a vibrational strength with my will and my belief that the name of Jesus would clear me.

So I say that because the tone, the vibration of that crystal, was what drove them out of me the second time.



So there has to be other methods of doing it, of course. I'm not going to say you have to go to the Inner Earth and have a crystal waved above you or call in the name of Jesus.

People can do it on their own, but it's very difficult. A lot of times, these entities will act like they've left, you know, "I'm leaving", you know, do the little walking noise and then sneak right back around and come in.

The best thing you can do is just make your body of a vibratory nature that it's very difficult for these beings to coexist with you.

David: We have one from Merwitch Mama. Ha, ha.

"Why are we still calling Gonzales, 'Gonzales'? If he's already been compromised and no longer even on Earth, why can't we know who he really is? It would go a long way toward getting more people on board with this."

Corey: He has family here that I wouldn't want to put in danger. I've already outed him, and it caused a lot of problems with the Alliance, the SSP Alliance. Half of the command and control structure will not show their heads, you know, for command and control purposes.

David: Right.

Corey: So I'm not going to do anything to cause any more damage.

David: I totally agree. Wanderer 1027:

"I am confused as to why the Alliance is more concerned about the Cabal exposing the dirt that the Cabal has on them than they are about giving humanity Full Disclosure. Should we care what individual factions of the Alliance have done more than our own ascension?"

"Also, why, **Corey**, are you concerned about the social effects of Full Disclosure? Society's already broken. We experience a dark night of the soul for a reason, don't we?"

So, I guess the first question is, "Why is the Alliance more concerned about the Cabal exposing the dirt on them than Full Disclosure?"

Corey: Well, because they will be standing next to them in tribunals. They were carrying out orders that were given to them for a long time. And in the process, many crimes against humanity were committed.

David: Stuff that would be so extremely compromising that people wouldn't feel very forgiving?

Corey: Absolutely not.

David: So regarding this idea that the social effects of Full Disclosure, the question seems to be confronting you as if you are concerned about Full Disclosure breaking down society, and they're saying society is already broken. This is just going to give us a useful dark night of the soul if we get Full Disclosure.

Corey: People have all these ideas about what disclosure is going to be if there's a Full Disclosure event. And it is going to be more than a dark night of the souls. Many people are going to die in the process. It's going to be chaos.

It's not going to be people holding hands singing "Kumbaya". It's going to be . . . We are demanding one of the most difficult times in our life. We're demanding we need this disclosure, but we don't fully understand how difficult it's going to be.

I mean, there are countries that have been victimized by the Cabal are going to find out a bunch of information. They're going to want to go to war with Cabal countries.

It's going to be a mess. It's not just going to be people that won't get out of bed and eat because their religion has been basically proven as wrong.

David: Right.

Corey: It's far more reaching than that.

David: So it would seem, then, that even a Full Disclosure, the most ethical way to do it would be in a series of stages where there's some acclimation along the way.

Corey: That's what the negotiations have been all about. The Alliance, the Earth Alliance, they believe that it's irresponsible to just drop it all on the people. They think it should be, you know, put out in a

slow way.

But in that case, if you don't put it all out at once, then you're always going to have somebody that's wanting to hold back little bits and pieces.

So I'm for Full Disclosure, but what I'm saying is, everyone out there, be careful what you wish for because it's going to be a lot more difficult even for those in the UFO community than what we think.

David: Well, if you think about, **Corey**, our own creative process when we were developing “[Cosmic Disclosure](#)” with the folks here at Gaia, we were looking at a lot of information that you could tell us about Draco and things like that that were VERY disturbing things.

And we did structure the show so that that kind of stuff came in later episodes after we'd had multiple episodes to try to front load the positive at the beginning.

So do you think there's a way that this could happen with Full Disclosure or are you saying it's like a data dump and it just all kind of comes blasting out?

Corey: That's what Full Disclosure is, is a complete dump of everything.

David: Right.

Corey: And everything . . . I mean, there's going to be a lot of disturbing information.

David: We have another question now from Akhaishimray, and it says, and we've heard this one before:

“Are you not allowed to film your interaction with the Blue Avians or Mica or even just a view aboard one of the spheres? And if so, why? A 360-degree camera would be ideal since that's difficult to fake.

“Why must disclosure only come from a CNN camera?”

Corey: I'm not allowed to bring any technology with me. I'm screened for AI every time I go up. You cannot bring technology with you.

So there's no way I can bring a camera with me and stick it in Tear-Eir's face when he's trying to communicate to me.

David: So you're saying that any technology from Earth could potentially have this AI in it . . .

Corey: Uh-huh.

David: . . . just as the . . . because you also mentioned it can exist as an electromagnetic source.

Corey: Right. Right. It's just security protocol.

David: Right. Is there also some reason, in terms of the Blue Avians and what they're wanting to be disclosure, that they don't want too much proof too quickly so that free will is preserved?

Corey: The way they see it, all the proof, that's all up to us and the process. The only thing they're concerned with is raising the vibration of humanity and raising our consciousness.

The way they see it, if they raise our consciousness, everything else will just fall into place.

David: Sure. Just because this is something that's come up a lot in the discussion forum, people have often said, "Why can't he put some kind of camera in his living room so that if a sphere shows up, he can catch it on film as it's happening, and then that'll be the big event that finally proves that he's telling the truth?"

Corey: Well, the one time that I did put a camera up in my room, the meeting did not occur that night.

David: Really?

Corey: Right.

David: What do you think is the reason for why the beings don't want a definitive smoking gun of proof given to us at this point?

Corey: Everyone has to go through their own process, their own spiritual process in raising their vibration and going towards disclosure.

People say that, "Oh, I'm spiritually advanced. I will not worship beings if they appear."

But that is not the history that these beings have seen with us.

We are programmed to worship something higher, and a being comes in, we'll be, "Oh, this is an

angel”, and try to apply it to whatever personal religion we have built up in our heads, and then start praying to them, which they already have a problem with.

David: Right. This is a subject we could talk about for a long time, but we are trying to get through a bunch of questions here.

We have one from Jenaceae:

“Okay, so are the Pre-Adamites then what we are calling the Annunaki or are they the step-link between the Annunaki and the elite Cabal sun god worshipers?”

“All the sun god people the Cabal worship have elongated heads, right?”

Corey: Well, the Pre-Adamites are basically fallen angels. 55,000 to 60,000 years ago, they pretty much crash landed here after a series of misfortunes.

They are not allies with the Draco, by any means. They've had agreements with them, but they kept the Reptilians in check in the past.

And it was after this last deluge or global catastrophe that caused Antarctica to shift its place on the globe and then be covered in ice that they lost all access to their technology and were then unable to keep the Reptilians at bay as they had done in the past.

So it's really hard. Annunaki is a term that can mean, you know, “from the heavens”, or it's kind of a blanket term.

David: Right.

Corey: So the Reptilians are often referred to as Annunaki and so are these Pre-Adamites.

David: Okay. We have John 1111:

“Hi, **Corey** and **David**. I am a wanderer, and as a result, a friendly, nonviolent person. But I was wondering if I would incur some sort of karmic debt by wanting to destroy Reptilians? Is there anything wrong with wanting to kill the bad guys or should we just let them be?”

Corey: We have to go . . . and this is going to sound really bizarre, but we have to get to a point in our journey – and it'll probably be well after disclosure – to where we're going to have to forgive those beings, or it's going to hold us back spiritually and karmically.

We're going to actually have to forgive the beings that have been torturing and murdering and enslaving us for millennia.

David: It would appear, if you look at the history of Atlantis, that seemingly benevolent beings, these Elohim, did decide for Atlantis to be destroyed and that a lot of those lives were lost. So it would appear that maybe on a level bigger than individual human free will that nature itself sometimes does things that resolve some of these issues or dramatically reduce the population of a negative civilization.

Corey: Right. These negative beings, they're being neutralized and taken care of right now, not only by higher density beings but by the universe itself, by the cycle that our galaxy is going through.

We still have to fight this battle against them. We have to fight for sovereignty, but after we win the battle, then we have to move to a point where we can forgive them, which is . . . I'm not at that point.

David: I also have often looked at what the Cabal is doing, where they think population on Earth is the enemy and population must be attacked.

And my response to that is, if nature sees something out of balance, nature will take care of it. It's not necessarily our right, or our privilege, if they want to think of it in such a dark way as that, to try to do these things when nature will take care of itself. It has cycles of replenishing and cleansing.

If there is to be a problem, it's not our job to go out there and try to do this.

Corey: Right. And sociopaths are the ones that usually rise to power in these organizations.

David: There you go. So now we have another one. This is from ARW 575:

“If we are all one, then I presume we are one with the Reptilians and all other entities. How can we evolve if we race around the galaxy battling with other entities? Are we not then just warring with ourselves? It gets confusing.”

Corey: You have mass consciousness. You have the mass consciousness of humanity, and I've described, when I was shown this mass consciousness being, that it was a traumatized schizophrenic basically.

David: Yeah.

Corey: There is some sort of a battle, but also a process that the Reptilians are growing and learning from these experiences just like we are. It's a hierarchical situation.

At the very tip-top, we are all one.

David: Well, what would you say also about the idea in The Law of One where they explain that we live in the illusion, and that the illusion is staged for the benefit of the development of consciousness?

Corey: It's all about consciousness, the development of consciousness. That's all they care about, these higher density beings. That's really the . . . Everyone is like, you know, what is the reason for life? What is the purpose for life?

It's all about the continual development of consciousness, not only on an individual basis but as a mass consciousness being that we're a part of.

David: Okay, now we have Selene 2:

“What, if anything, does CERN have to do with manipulating the Earth's magnetic field? Anything you can offer there would be useful. Many things for your wonderful disclosures.”

Corey: From what I understand, CERN is one of these multipurpose-type technologies. There are different groups of scientists going in, trying to achieve different goals.

They're using it as some sort of a . . . They're trying to interact with the Earth's magnetic field. They're using it trying to create portals. They're using it to also develop torsion field technologies.

It is a laboratory that has multiple purposes. It's not just there to create a wormhole. It's not just there to interact with the ley lines. It is a multipurpose technology.

David: I'll just throw in here that in talking with Henry Deacon, he actually worked on CERN for a while as a job. And he said that it is so difficult to actually get the particles to hit each other that it requires people who are intuitive.

And he was one of the people who was psychic enough to be able to intuitively work the controls so that you'd actually get particle collisions.

I'm wondering if that lines up with anything you heard?

Corey: It doesn't line up with what I've heard, but it makes total sense.

David: Right. Next, we have DJ Miss Mixit:

“**Corey**, could you please ask some of the beings from higher vibrations the best, most efficient tools for clearing the pineal gland.

“Is there a Hertz frequency I can make? Is meditation enough for me to simply imagine it being cleared?”

Corey: Meditation and diet are the way to go. You want to make sure that you can remove the calcification in your pineal gland, but also you want the pineal gland interacting with your higher self in a conducive way.

So you need to have yourself on the right vibratory level through meditation.

David: I would also just point out, one of the things Peterson said is that the halides, which would be like chlorine, fluoride, etc., pass through the blood brain barrier and attach to the little crystals in your pineal gland, and that's one of the main things that causes calcification.

Corey: That's true.

David: So have the beings told you to avoid tap water and things like this?

Corey: Yes, I only drink spring water at home.

David: Okay.

Corey: Right.

David: Next, we have one from Inscizor:

“My questions are about densities. What density would Jesus or the Buddha have been considered to have moved into after being here?”

“How about the in-between live state before one is to reincarnate? How does that fit in with the idea of densities of consciousness?”

“Is heaven considered to be the next, say the fourth or higher, level of consciousness, or is it something entirely different?”

Corey: The way densities have been explained to me is it's all about consciousness. It's different vibratory states of consciousness.

And once you reach a certain vibratory state of consciousness, as we've stated, you can control matter with consciousness.

So you begin to change your environment as you go up the octaves consciously.

David: Okay. We have L. Mensah 732:

“Can mass consciousness toward a specific goal via the Internet be as effective as being physically together in one place?”

“For instance, I guess this is **Heather Sartain's** episode, she mentioned people being on one continent and how that would affect Earth's rotation.”

So I think what they're looking at here is could we do, like a mass meditation and reduce terrorism without everybody having to be in the same room like they were in the original transcendental meditation studies?

Corey: Yes, that definitely does work. You don't have to be in proximity with other people. But when you get a lot of people that are . . . they have practiced disciplines to where they can meditate deeply, you get a lot of those people in proximity, there is a power to it, for sure.

David: I agree. So here's another one from Sassafrass 7:

“Good stuff. I have so many more questions. How do the Reptilians reproduce? Do they have a gestation period and then are born similar to mammals on Earth?

“But if they are fourth-dimensional beings, do they need to be born at all or do they just create their bodies with thought? I understand they do eat. Unfortunately, they enjoy eating people.

“I thought a fourth-dimensional being would not need to eat. Does this mean they are doing this only for sport or something like that?”

Corey: Yeah, well, this all goes back to our different belief systems on what dimensions, densities are. A lot of people think that a fourth-density being could be standing right next to us, and we wouldn't see them. We'd be passing through each other. You know, we couldn't hold hands with them.

That's not at all the case. It's just they have a different consciousness vibration.

What I'd normally say is, what do you consider a dog or a bacteria? You know, second, first-density life, you can interact with them, no problem.

David: Right. Sure. As far as the Reptilian breeding cycle and birthing cycle, is there a sexual reproduction that leads to a pregnancy and a birth?

Corey: Exactly. Yes. And they also use cloning.

David: Okay. Lastly, we have 23 Window:

“I wanted to put something forward. The name 'wanderers' and 'starseeds' alone come with a positive connotation, but now, I'm hearing that the Cabal or MILABs identify these kids early along, take them, and fractionalize their brains into doing work for the Cabal.

“Weren't these people sent here in the first place to do good for humanity? Yet, the Draco has infiltrated the Cabal and figured out how to brainwash them and control them for their own purposes.”

Corey: Yeah, they basically hijacked their mission. That's the whole point. They hijack their mission. They come here with certain abilities, and then they exploit those abilities.

And in doing so, they're co-opting the enemy the way they see it. They're causing . . . These starseed beings are coming here to effect positive change on the planet.

The Reptilians, for instance, do not want positive change on the planet, so they're corrupting these “soldiers” to fight for them.

David: Well, this obviously is not an airtight system in which all people who are wanderers are being completely compromised.

So could you speak to that a little bit, in terms of how would someone navigate this successfully if they are an ET soul and still be able to do what they're supposed to be doing on the planet?

Corey: Well, stay away from any government organization that tells you you're special. Ha. That's number one.

And practice humility, concentrate on your own personal journey, and meditating on what your mission is. And once you've been awakened to your mission, go for it.

If you do that, then you're going to effect positive change and combat the groups that are co-opting the starseeds.

David: That's all the time we have for in this episode. I'm your host, [David Wilcock](#) here with **Corey Goode**. This is “[Cosmic Disclosure](#)” on Gaia. And we thank you for watching.

[Cosmic Disclosure: Astral Projection and Our Place in the Universe with William Tompkins](#)

Season 7, Episode 16

David Wilcock: All right. Welcome back to “[Cosmic Disclosure](#)”. I'm your host, **David Wilcock**, and I'm here with **Corey Goode**.

And in this episode, we have more of the very stunning new information coming to us from our World War II veteran insider **William Tompkins**.

* * * * *

ASTRAL PROJECTION

William Tompkins: When I was just a boy, and I was, like, seven, eight and nine years old, I used to fly a lot. Now, I didn't have an airplane. I just flew.

We were living in Santa Monica. We were living in Hollywood, and I flew a lot, mostly at night, but a couple of times in class, in school, recess, I'd just go behind the building, and I'd take a flight.

And I'd sometimes . . . I'd put my arms up, but most times I'd just go out.

And so I could fly all over Hollywood, San Fernando Valley, go down to the beach at Santa Monica, fly up to Malibu, fly all the way down to San Pedro, look at the Navy ships and the dry docks in San Pedro, and fly over LAX and come back.



I had a hard time flying over LAX. There was a lot of stuff going on, so I kept myself away from the airports as much as I could.

A few times, after I'd had fun just flying around low key – and in particular, it's more fun at night with the lights – I'd just shoot out, out into the galaxy. And I flew way above 186,000 miles a second, way, way above that.

And it took everybody a long time to figure out that even the Germans could fly faster than that, and certainly the extraterrestrials could, okay? But what I am saying I do, is I fly out there.

And one time I flew into . . . it was the admiral's command ship of a Reptilian space navy. I flew right into his office. I could see, hear and smell everything that they were saying.

To me, it came to me in English, just like when I flew one time over Russia. Admiral Sergey Gorshkov had been building a whole series of futuristic ships that don't even look like they're from the planet because they were built with stealth.



Sergey Gorshkov
Admiral of the fleet of the Soviet Union

I flew over the base, Vladivostok base, and I actually flew around the base. I went down, looked into the edge of the construction facilities, came back up high, flew into Sergey Gorshkov's office, and I could see, hear and smell the coffee in his office.

And his language . . . which language? English. All of them were talking English. Okay?

I actually got into a research group in the Navy where I was an adviser to this psychic type of whatever that I'm doing here.

* * * * *

David: So that's some pretty interesting stuff there. We're hearing that he has been able to do this ever since he was seven or eight years old.

And **Corey**, one of the things that jumped out at me, I was five years old when I had an out-of-body experience. I woke up floating over my body, and it was the event that got me to study ESP.

So I started to do psychic experiments by the time I was seven years old. I wanted to get another chance. I was only able to do it once when I was a kid.

Corey: Yeah, I thought it was commonplace. I thought everyone could do it. I was doing it . . .

David: This was something that happened to you often?

Corey: Mm-hmm.

David: From what age?

Corey: The age of four and five years old it was spontaneously happening, and then I was able to control it through my youth.

We'd be on long car drives. I'd be bored, and instead of asking, "Are we there yet?", I would just project myself outside of the car, and I would float and fly above the signs as we passed, above the overpasses.

And I thought it was something everyone could do.

David: Is there something about extraterrestrial lineage in the soul that makes it more likely that people will be able to do this?

Corey: Well, let's say that, in a previous life, you were a more advanced extraterrestrial. You had advanced consciousness abilities, and you agreed to be incarnated here on Earth as a human.

We still have that same oversoul that has the same knowledge. So that knowledge has to slowly trickle into this conscious being that we agreed to become.

David: Is there any reason to believe that if a person goes through excessive trauma, that that trauma might propel them to be able to develop astral projection?

Corey: Yes. That's actually a technique that is used in the programs. They will cause people to astrally project by inflicting extreme trauma upon them.

David: How does that end up working? Why do you project out of your body then?

Corey: That is a . . . It's an escape or a protection mechanism that our psyche has. It's a disassociative ability that our psyche, and we have spiritually, to disassociate and divorce ourself from what is occurring.

And once they program a person through trauma to be able to project out of their body, then they start training them how to do it for operations.

David: And what would be an example of an astral projection?

Corey: Very similar to remote viewing. It's going to be going to gather intelligence at a remote location.

David: Well, it seems that this is a very ancient technique, isn't it? I mean, this is something that mystery schools have talked about for a long time.

Corey: Right, it's a heavily suppressed ability that all humans have.

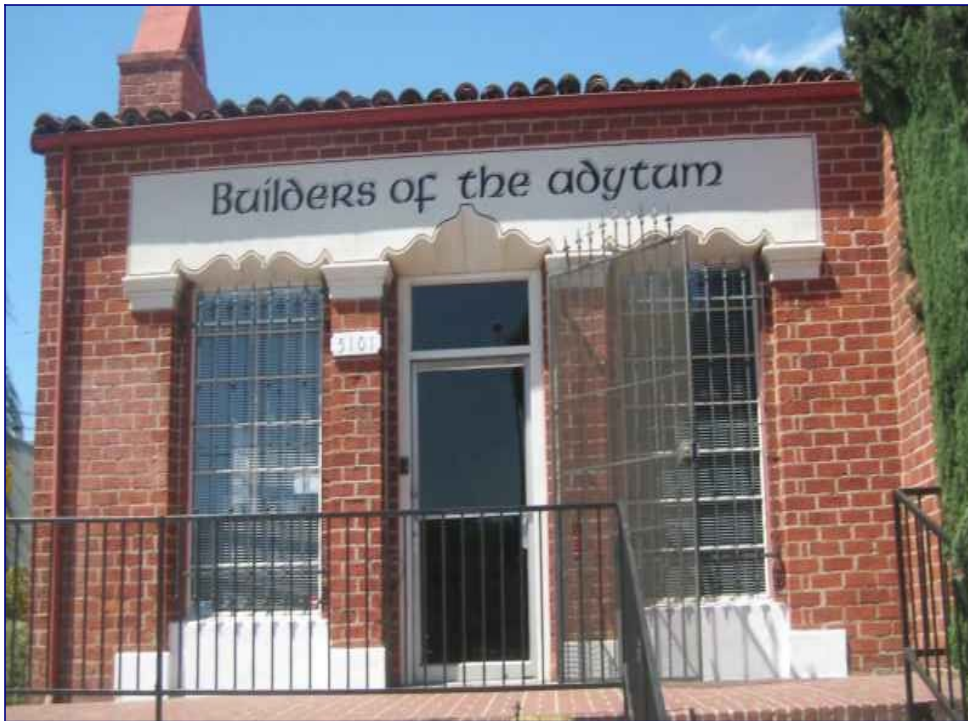

David: One of the things that, maybe, our viewers are not aware of, there is one particular secret society called BOTA, or Builders of the Adytum, and the Adytum, believe it or not, is a room that has an altar with a sacred book inside with sacred knowledge.



And the room is completely walled off. It's usually a cylindrical room, all bricked in. You can't get in at all except in your astral body.

And so the key for the initiate is, can you astrally make it into that room and then read the book inside the Adytum, and only if you can accurately recount what the book says have you then become a true initiate.

Have you ever heard of anything like that?

Corey: Well, I mean, there were similar exercises that we were all put through.

David: Really?

Corey: Yeah. You would have to identify an object in another room, its color. It wasn't as . . . We weren't reading books, but you know, we were children.

And they would have us identify toys or paintings or different things in another room that was walled off, and that no one in the experiment, at that time, knew what was in there either. So you weren't getting psychic hits, or you weren't front loaded in anyway.

David: Some people might be inclined to dismiss **Tompkins'** testimony based on the idea that he's saying, for example, he went into the office of an admiral of the Reptilian navy, and that he's hearing things in English when they clearly are not speaking in English.

And the same thing with the Russian where they had these unconventional aircraft, stealth aircraft.

Corey: I have heard of that before, that your mind – your astrally projected astral body – is able to interpret other languages to the language that the mind uses.

David: So there's sort of a natural translation function going on.

Corey: Not all the time, but some people have that innate ability.

You can't just astrally project to a lot of these black bases. They're protected by people that have remote influencing abilities and are enhanced by technology.

I've heard them called “Those Who Scatter”. They'll scatter your thoughts.

Also, shadow beings that will protect facilities from astral projectors. Astral projectors will go try to get into a facility, and all of a sudden they'll get this real dark being that's now chasing them all over the place.

So they do have astral security.

David: All right. So in our next segment, we're going to have **Tompkins** blast us out into the cosmos, and specifically, we're going to hear what he has to say about settlements on the Moon.

* * * * *

OUR MOON

Tompkins: Well, first of all, it's not your Moon, and secondly, it's not a moon. It's a command center for a region of this part of the Milky Way galaxy. That's what it is.

And it doesn't rotate. Everybody forgets the thing doesn't turn. Okay? So it's not a moon. It's not YOUR moon. It's a command center with probably 25~35 different civilizations in there, all of which operate out here for this part of the Milky Way galaxy.

And, yes, some of those people actually are at war with each other, but they have personnel living here. Their families live here. The kids are getting educated. They get young. They get older. They get married. It's a big hunk. It's a big facility.

* * * * *

David: So **Corey**, what was your reaction as you saw this segment just now?

Corey: It's exactly what I had stated in the past. There are a number of factions that have territory on the Moon that they operate in. And there will be blood enemies for millennia that are operating within a kilometer or two of each other, I mean, groups that you do not get together no matter what.

David: Now, he mentioned 25 to 35 civilizations. I'm curious how well that dovetails with what you've heard?

Corey: That's probably about right. There are a lot of the genetic farmer races that have 'observation posts', is what they call them.

And they do use it as an observation post and a station that they go back and forth doing these genetic experiments on us from.

David: Now, one of the things that jumps out at me was, I kind of thought of this, like you said, as an outpost or maybe a stopover point, whereas he's saying that you have families living there. You have children being educated there, growing up in these lunar bases.

So we are dealing with what would appear to be like a permanent housing for potentially large populations of people from several, you know, 25~35 civilizations.

Corey: I mean, it would be similar to us having a marine base in Europe. The soldiers have families that are there with them. It's going to be one of those scenarios.

I had not heard intelligence of families and children. The information I had received was that they were more sort of like military outposts.

David: When I went to Japan, I went to Tokyo, the main city, and it's amazing when you're there, and you look out, and you see something that kind of looks like Manhattan, but it is so big.

Tokyo is so incredibly large, there's such a density of buildings that you can't even see to the point where that highly compressed density of buildings stops.

So when we have a city of that size, it's a very small geographical footprint, but you could potentially have 20, 30 million people living there.

I'm wondering if the level of development on the Moon in some of these territories these people have is sufficient enough that you could have a population that large in a small space.

Corey: It's all about technology. If we were not so technologically developed, it wouldn't be possible to have a city like Tokyo.

They have mastered all of the energy needs, the protein requirements that people may need, everything that's needed to process waste on a much more efficient level than we are.

So, yeah, they're able to have a much higher population density than we are.

David: Are there immigration requirements that would prevent anyone who is not part of their indigenous culture from being able to even see the inside of these cities?

Corey: Absolutely. You don't have one group going into the cities of others. I mean, it's like the UN or kind of like how Antarctica is carved up for all these different countries.

It is undisputed territory, and they do not cross over or invade.

The Moon was made sort of like a Switzerland zone, a conflict free zone, after some major, major battles that happened in our history. And they left some of the remnants of that battle on the Moon as a testament and a reminder of the battles and how bad it got.

These are the conflicts that led to these treaties being signed between the different genetic farmer groups, some of these more negative groups that we're talking about, that allows them to live and operate in close proximity without being at war all the time.

David: **Pete** Peterson has an insider who came from the Russian space program, who told him that if we were to be able to see the dark side of the Moon – which as **Tompkins** noted, it's always against our view. We can't ever look on that side – that it would look like Manhattan at night.

Meaning the entire circular area of the backside of the Moon, if that circle could be turned towards us, the whole thing at night is just literally covered with lights.

Corey: Yeah, there's one particular, I think it's called Luna City, that has a lot of light.

But you have to also note that they have a type of cloaking that goes over their buildings and structures that looks just like the rest of the arid terrain of the Moon.

David: Oh, wow!

Corey: So you could fly over and just see craters when actually that's a projection over a base or an outpost

David: That is interesting because, as we know, retired Major **Bob** Dean, according to what I heard from Jacob, my insider who met up with him at a Project Camelot event and recognized him from the Secret Space Program . . .

Corey: I'm pretty sure he did at least one 20-and-Back.

David: Yeah.

Corey: That's my opinion.

David: But one of the things that Dean said while he was talking to Jacob was that there was an island in the Pacific where half of the island looks like an island, but it's a cloak, and that there's a very important base there.

And if it wasn't for this hologram that makes it look like it's just an island in the ocean, you'd see this amazing thing.

Corey: Oh, yeah, they can disappear entire islands.

David: Wow! So this is stuff that could be used on Earth right now.

Corey: Absolutely.

David: You can confirm that.

Corey: Yeah. It can be used over Antarctica. It could be used any number of places.

David: All right. Now, he also mentioned that the Moon is a command center. How much of this is also inside?

Corey: Almost all of it. The majority of it is under the surface of the Moon in these deep huge fissures, cracks and lava tubes.

David: And one last thing was you mentioned that we have some new art of the Lunar Operations Command.

Corey: Yes. Yes.

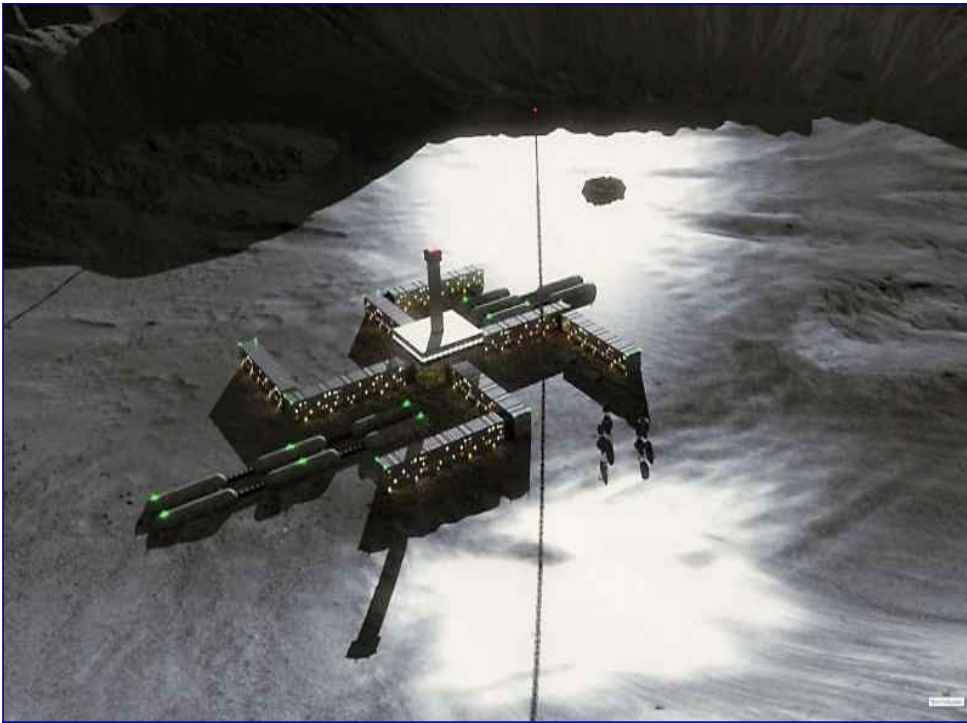

If you look at this image, this is an image that I commissioned that is a 3D rendering of the swastika-looking arrangement of buildings that . . . how the LOC originally looked.

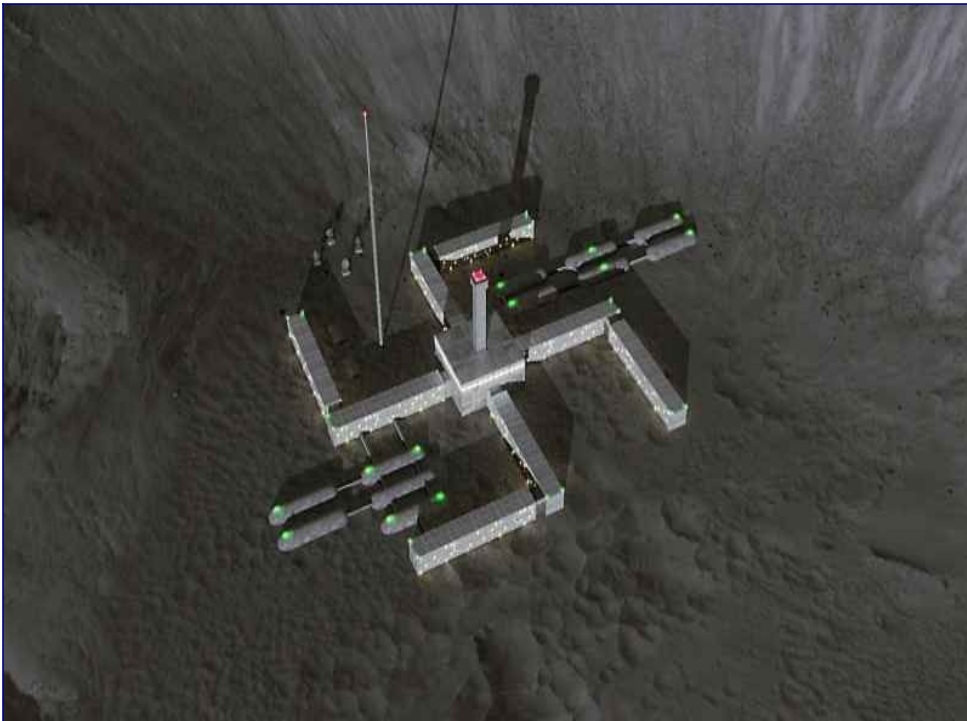

David: Okay.

Corey: And then I have another image that shows how it was built out to cover up the swastika.

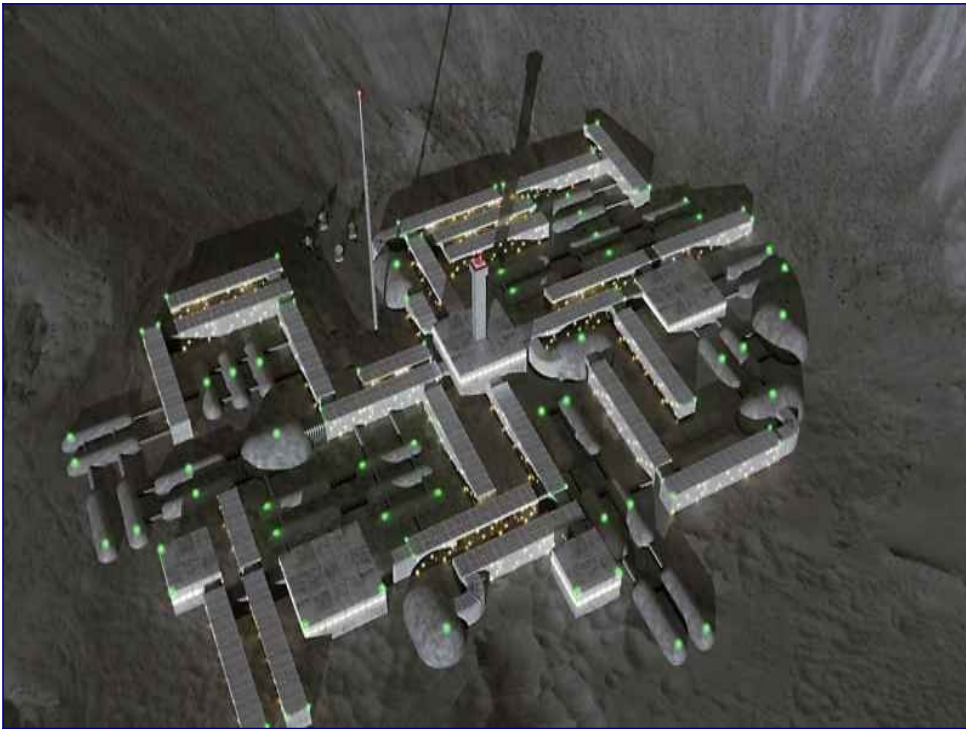

David: Interesting. All right. So in this last segment, we have one final set of words from **Tompkins** for us in this episode, and this is his statements on how he sees our place in the universe based on his own personal and stunning insider knowledge and direct experience with extraterrestrial contact, including Nordics. Let's take a look.

OUR PLACE IN THE GALAXY

Tompkins: We've now accepted that we have 200 trillion galaxies. Not million. We have 200 trillion galaxies out there.

I mean, what . . . We are so naïve of what's out there. It's totally unbelievable. Millions and millions of planets out there – very small things and things that make our Star look like kid stuff.

Our star is just a little dot over on the side – even our galaxy.

And while we're talking about that, this subject comes up all the time, and it's an appropriate time to say it.

If we can visualize us as the center of the Milky Way galaxy, we're reaching out like this with our arm.

Everybody in this room, and all the audience that's going to be watching this, has to realize this is one of the arms of the Milky Way galaxy. You're located at my first joint.

You're not down . . . Wait a minute! You're not down where the action is. Even in the Milky Way galaxy, you're not downtown where ALL the action is.

You are out here at this tip, which in time, you're going to get thrown off because the galaxy rotates. The galaxy rotates, all of them do.

They rotate, so the tips get thrown off. Other galaxies come by, and they pick up that stuff. So you may be going to the next galaxy several weeks from now. Okay? Takes quite a while. [Smiles]

So to realize that you're not downtown, you're just one of the castoffs.

This little Solar System thing that you've got here – it's . . . You're out in the boonies.



And it's interesting that we have to address who we are, where we are, and what we know and realize that the universe is unbelievable. And so opportunities for young people in this country, all over the world, to be involved in this commercially, okay . . .

Come on. Forget about carrying a big gun. There's too much of that. That's not the right step. You've got to have the largest . . . enough to be able to stop it, and this is where the Navy has been saying this for 240 years. If you have a large enough navy, they'll back off.

You don't need to use a shooting navy. But if you don't carry that, people are going to really make it hard for you.

And so to me, I think we're just starting. We've just got the tip of the iceberg of where we can go and what we can do, and it's unbelievable opportunities.

* * * * *

David: All right. So, wow! That's a very sobering reminder of the awesomeness of our cosmic identity.

I've been quoting from the latest NASA studies, which have revealed that there are as many Earth-like watery planets in our universe as there are grains of sand on Earth, on the entire planet. All the grains of sand put together – there's a watery planet like Earth out in the universe for all of that.

So it's a staggering number.

Corey: It's a template that's all over the cosmos.

David: And these watery planets in this theoretical mock-up that NASA has put out, they're looking at, okay, well, maybe one out of a hundred of them is going to have life, and then maybe one out of a hundred of those is going to reach intelligent life.

But based on what you've told me before, it seems like intelligent life for a watery planet is far more prevalent than that one out of one out of 100 thing.

Corey: Well, yeah, and also, you have to understand that each solar system has its own dynamics. So there are going to be times of developed societies in the solar system, and then there are going to be

cataclysms - cycles that occur.

Then they'll have long periods of having more basic life that inhabit these planets.

David: And if our conventional estimate of the age of the universe is about 13.8 billion years – there's different opinions, but that's one of the common ones – then that would mean that there could be civilizations much older than ours that already reached very high technology.

Corey: Oh, yeah. Come and gone.

David: So the idea that we are the only intelligent life in the universe, in light of all these new statistics, is totally ridiculous.

Corey: Yes, it's beyond ridiculous. It's arrogant. You have the right mix of minerals, distance from the sun, the planet being seeded with the correct enzymes or proteins from comets. Then you have all the building blocks for basic life, and it's everywhere.



And now that they've found out that the stars produce water, . . .

David: Right.

Corey: . . . that's where a lot of the water's coming from.

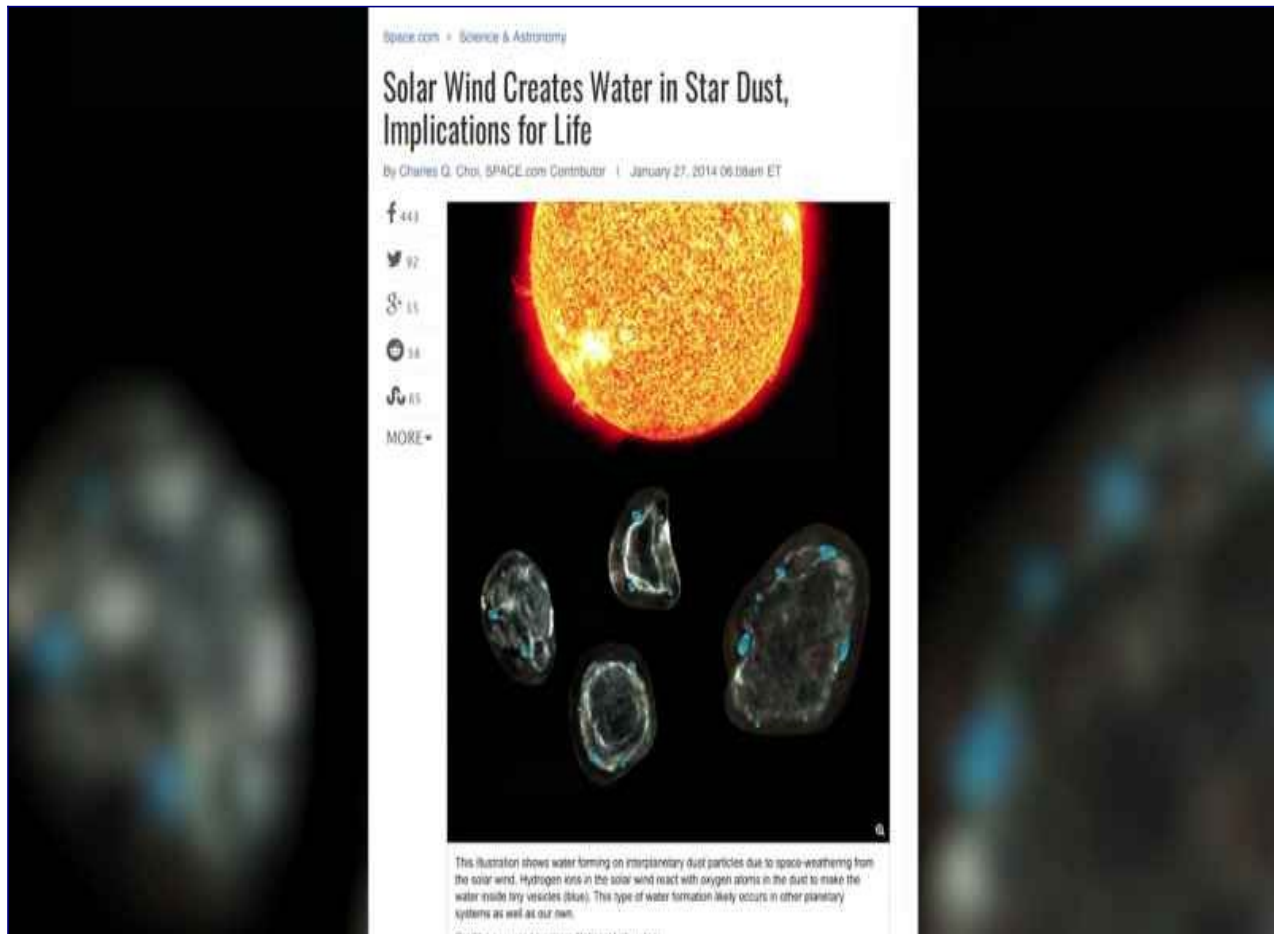

And the Sun is also producing the harmonic wave that allows life to come about.

David: Yeah, this is something I've done a lot of scientific validation of. If people also watch “Wisdom Teachings”, they're going to hear, in many of my DNA episodes, astonishing proof.

We went into Wilhelm Reich and how you can, in fact, generate life just out of electrifying a rock and water. All you have to do is that, and you'll eventually get life to form.

Corey: Right, and also where in the galaxy this solar system is, is also going to depend . . . is going to dictate how advanced and how quickly life advances or progresses.

More towards the center of the galaxy, things are occurring a lot quicker. Time is occurring differently.

There's a lot more going on, civilization wise, towards the center of galaxies than in the cosmic boondocks that he was talking about.

David: I did find that fascinating because my insider Jacob, who was very extensively knowledgeable about the Secret Space Program, claimed to have been to over 200 different off-planet sites, to have seen over 400 different types of extraterrestrials, and he was the guy who gave me a lot of information that correlated so well with what you've brought up.

Jacob was telling me that, yes, the center of the galaxy is so much more advanced, and there's so much more going on there that it's almost incomprehensible to us.

Corey: Time flows differently. Energy, everything . . . Towards the center of the galaxy, things are occurring, from our perspective, much quicker.

David: Now, **Tompkins** also mentioned that there were commercial opportunities. It's not just about going out there with a gun.

What do you think could happen in a post-Full Disclosure world where people will have the ability to potentially even have a portal in their home, and in the course of one day maybe even travel far outside our Solar System, meet with other people, travel to other places? What kind of society is that? What kind of businesses could we start to develop at that point?

Corey: Well, there's already a lot of commerce going on between our Solar System and the other solar systems, but it's being controlled by a very militant and fascist group.

If it's put in the hands of the people, we're going to be able to do this – start bartering – from our own best interests.

Right now, a lot of the people in the secret space programs are somewhat forced into it.

When it becomes an all volunteer navy-type situation for space, then we're going to have people that

are bringing more creative energy to their mission. And if it's not a military mission, it's going to be more of a mission for commerce.

David: Some people watching this show might be cynics, and they would say, “Well, what could we possibly be offering to any other cultures? We're like Neanderthals, troglodytes, in comparison to these people.

“Even if we developed the portal capability, even if we could pop over to a solar system outside of our own and visit an advanced culture, if they've got gigantic buildings made out of transparent aluminum crystal, what are we going to do going in there they would possibly want from us?”

Corey: Well, there are going to be some civilizations that are so much more advanced, there's nothing that we're going to really have except for maybe some biologicals or genetic stock that we are willing to trade from our planet.

A lot of them, that's what they're interested in. So the more super advanced civilizations . . . we're not really going to have much that they're going to want to trade.

But there are a lot of civilizations that are very close to ours. Our level of development is similar to theirs to a point to where they're buying vessels from us.

We're engineering technology that nonterrestrial groups covet, they want, and they're willing to trade for it because we're known as very diligent and brilliant engineers.

David: Could there also be job opportunities for people who might be, let's say, artists or musicians or teachers?

Corey: Absolutely.

David: That kind of thing?

Corey: Yeah, I would expect a lot of exchange programs when it comes to the arts, because it's . . . All the planets have some form of art.

David: And how much of a wide diversity are we looking at of places where artists or teachers or musicians could go and volunteer their services once this opens up?

Corey: Just about every planet that has a human-type civilization. The reason that they tell us not to call them nonterrestrials, or ETs – they tell us to call them people – is because there's very little difference, genetically, between us and them.

David: Right.

Corey: They are people, and people have desires. They have interests. We can cross-pollinate our sciences, our arts, with other star systems that are interested in our art.

David: So there's a potential in our future where we could have educational programs, where we're going to help people to get to a point where they would be welcomed as diplomats, ambassadors, teachers, sharers of knowledge, but it's going to require us to level up our spiritual maturity before we're ready for that.

Corey: We're going to continue to be sort of isolated until we go through this consciousness renaissance. Once we do, and we're not as damaged, we don't have as strong of PTSD, then we're going to be able to go out and interact with them.

David: Well, that's a very fascinating and hopeful message.

We'll see you next time here on “[Cosmic Disclosure](#)”. Special episode with **William Tompkins**. I'm **David Wilcock** here with **Corey Goode**, and we thank you for watching and supporting us.

[Cosmic Disclosure: Allying with the MIC SSP](#)

Season 7, Episode 17

David Wilcock: All right, welcome to “[Cosmic Disclosure](#)”. I'm your host, **David Wilcock**, and we here with **Corey Goode** for another fascinating update. Without further ado, let's hit the ground running.

Corey, welcome back to the show.

Corey Goode: Thank you.

David: More recently, you have started to interact with a Military-Industrial Complex Secret Space Program. There are a lot of movies out there that, according to **Pete** Peterson in one of the briefings he

gave me recently, are showing hardware that this group actually possesses. And they're putting it out in the open – a movie like “The Avengers” that has a flying aircraft carrier.

So what is your knowledge about how this MIC group is working with Hollywood in maybe getting us ready for things that they're going to show us?

Corey: Well, according to Sigmund and everyone else I've talked to, they are planning on doing a slow, I guess, disclosure of a certain type of secret space program that, as I stated before, the DIA, NSA and Air Force have control of.

And they plan on making this program known, which most of the activity happens within 500 miles of the Earth. They have space stations and manned satellites within that 500 mile range.

And that's most of that zone that they have control over.

David: In Ronald Reagan's own handwritten book of his memoirs – comes out in 1985 while he's still President – he kind of let slip that he was aware that we could put 300 people up into orbit. And there was certainly nothing having to do with the space shuttle that would have anywhere near the capacity to hold 300 people.

So what was he talking about there?

Corey: He was referring to this program. This program . . . There are several decent sized space stations. There are manned satellites that have anywhere from three, six, eight men on duty, or I should say people on duty, that are serviced by these triangular craft. And they exchange personnel and supplies.

This is the information that our President recently received in a briefing.

David: Really?

Corey: He received a very low-level briefing and was upset because he knew it was a low-level briefing.

David: We have reason to believe that Trump's uncle was involved with some of this classified information as well. What is your knowledge about that?

Corey: His uncle, whose name was John G. Trump, and was a MIT professor or scientist at the time, had actually been called to go out to Tesla's property after he passed away to help remove all of the paperwork and experiments.

So this could very well explain some of the comments that the current President made very recently.

If you remember his inauguration speech, he mentioned a few interesting things about hidden technologies at the very end.



DONALD TRUMP – 2017 INAUGURATION SPEECH

“We stand at the birth of a new millennium, ready to unlock the mysteries of space, to free the Earth from the miseries of disease, and to harness the energies, industries, and technologies of tomorrow.”

David: So he's describing technologies that could include free energy, that could include age reversal, or at least disease reduction, stuff that seems pretty out of the box.

And it's a big cowboy move for him to make promises like that in his inaugural address. So granted,

people would say, “Well, yeah, politicians, they just make stuff up all the time”, but is there something more to these statements?

Corey: Well, you take that his uncle was involved with this free energy-type technology, or allegedly, then he may have heard things down the family line about free energy being invented and available.

So he may have had that information. And when he received the briefings, he realized that he wasn't getting the full information from his security advisers.

David: You seem pretty confident that Trump thinks that he only got low-level information when he was told about the Military-Industrial Complex Secret Space Program.

Corey: Right. He wasn't told about any free energy, any of these healing technologies, in this briefing. But he sent a secret presidential memo, according to the information I received, to the Department of Energy, to the DoD and another group, requesting that, or basically demanding that they declassify over 1,000 patents . . .

David: Wow!

Corey: . . . out of 5,700 or so. And, I guess, some people may not know, but it's documented that there are at least 5,700 patents that have been deemed harmful to national security.

David: Why would somebody invent something and then thousands and thousands of things are not being allowed to be shown to us?

Corey: Well, it comes to, I guess, the almighty dollar. Advanced energy technology would put the oil companies out of business. Advanced healing technology would put people even more powerful – the pharmaceutical conglomerates – out of business.

David: So what happened when the President asked for these patents to be declassified? That seems like a really strong and bold move.

Corey: Yeah. He received the typical pushback, and these groups said it would take at least 10 years for us to get all of this ready, but we'll start working on it right away.

David: 10 years?

Corey: Yes, and . . .

David: That's ridiculous.

Corey: He immediately pushed back that he wanted them released in the next three years.

David: You've mentioned Sigmund and that he has started to, perhaps, believe that what you're saying is true. He's taken hair samples from you. He's proven that you were at these places that you say that you were.

How is he handling the fact that you may know something that's true? What is he doing with that knowledge?

Corey: He basically hit the roof. He was extremely upset. He approached his superiors in a very upset manner and told them, "Listen. I feel like you're not giving me the full information."

Some of them became concerned because they felt like they weren't getting the full data. So they have allowed him to start an investigation to investigate this Navy program.

David: 'They' the higher ups?

Corey: Yes. His superiors have then authorized him to begin this investigation, which he's been undertaking.

David: What is the nature of that investigation?

Corey: To establish the details and existence of a Navy secret space program that is more active in the outer Solar System and other solar systems. They really want to find out the details of this alleged Navy Secret Space Program, because as he said to me – and I will clean it up – he said, "I used to think we were the tip of the spear, but I found out we're the f**ing Coast Guard."

David: Ha, ha, ha.

Corey: And not to put down the Coast Guard in any way, . . .

David: Sure.

Corey: . . . but he was talking about strategically. They thought they were the tip of the spear, keeping the planet safe and surveilling the planet, when they're just basically the Coast Guard. And the Navy Secret Space Program and other programs are the tip of the spear.

David: Do they have anything beyond this 500-mile radius around the Earth that you said?

Corey: Yes, they have very small locations on the Moon, and I hear further out, but I haven't verified where all of their assets are.

David: Anything on Mars?

Corey: I've heard rumor of that, but that I haven't verified.

David: When you say, 'very small', how many personnel would be able to work there?

Corey: I haven't had numbers, but I would assume it would be maybe 30 at the most.

David: Oh, wow!

Corey: Yeah, very small facilities.

David: Right. What might they be doing out there? What would be their objective of being there?

Corey: That's their mandate, to protect the planet and surveil the planet.

David: So it's like a surveillance and military defense outpost.

Corey: Right.

David: So the MIC group is Air Force. Is this the extent of the Air Force's involvement in a space program, or is there another aspect to the Air Force that is in what you're calling the Secret Space Program?

Corey: They're involved in other aspects of other programs, but anything that they're working on, they don't communicate that information to this MIC Secret Space Program because they don't have a need to know.

As a matter of fact, this MIC Secret Space Program, when they're out in their space stations or flying around, they're told that anything they see that flies by that's much faster than what they are flying, they're told that those craft are concept craft that their peers are developing.

David: Has Sigmund started to utilize you as an asset in any way to inform others who may be curious about whether this Navy Secret Space Program is real?

Corey: He had prepped me that he was going to start having me do briefings of various VIPs.

David: Oh!

Corey: So I was kind of preparing myself for that. And the last time we were here shooting [Cosmic Disclosure](#), I was very shocked, and I believe you were too, when we saw in the same hotel we were staying in, this SAS forum was there.

It's a Human Spaceflight and Exploration Forum.

David: Yeah, I have to say that walking around and seeing all that in physical form right in front of me, it did literally make the hairs stand up on both of my arms.



Corey: Right. And I was shooting video while I was there for my vlog.

Corey SHOOTING VLOG

“What are the chances of the Human Spaceflight and Exploration Forum being at the same hotel as me?”



And I captured pretty much all of the signs they had out in the corridor showing all the different energy technology, propulsion technology, they were going to be discussing. So it was a significant meeting.

David: Now, what happened as far as that meeting being set up? Was that in any way designed by the MIC group because we were here?

Corey: It's pretty interesting, but I think that had been set up for a long time. It just seemed to work out well for getting me to talk to a few of the participants.

And I was very shocked early in the morning when I was supposed to come and shoot here. I had a knock at the door, and there was a person standing there.

And he greeted me with the proper information that would signify that he was in contact with Sigmund's group, . . .

David: Wow!

Corey: . . . which caught me off guard. And I wasn't expecting to do a briefing. I'm sitting in my sweatpants and a t-shirt.

So he asked me if I'm willing to do a briefing. And I was like, "Right now?"

And I looked, and there were four other people in the hallway, three of which were people that were going to soon come in my hotel room, which made me very nervous, who I would then give a briefing to.

And one of them introduced himself to me as a former astronaut who flew shuttle missions. I didn't recognize him. He's kind of a balding guy. He had a Masonic ring on.

David: Okay.

Corey: And I talked to him, and I talked to a physicist who was there. And he was a physicist engineer. And then there was another person that was part of the military-industrial complex that had a lot of connections.

And I started to give them the briefing, just like I have in [Cosmic Disclosure](#) from the very beginning.

And they all started looking very nervous and bewildered when I started with my story. Yeah, they were very uncomfortable.

David: What kinds of questions were these guys asking you, and how did you answer them?

Corey: The person who started hitting me with the most questions was the physicist engineer guy. And he started asking me questions way over my head.

And Ka'Aree had told me that she would assist me in these briefings when needed. I had no idea in what capacity. I thought she would feed me information.

David: Right.

Corey: All of a sudden, she started basically speaking through me and answering all of these questions. His eyes were getting bigger and bigger. And, finally, he stood up and threw his hands up in the air and said, "I cannot accept any of this."

And he turned around and stormed out of the room.

David: So just so we're clear and people don't make things up online, you were still speaking in your own voice, not in a woman's voice or something like that.

Corey: Right.

David: But you're just able to hear words in your mind and then verbalize them?

Corey: Right. Yes.

David: Okay. When he stormed out of the room, what happens next?

Corey: It turned a nervous situation into a 'I didn't know what to do next' situation. And the other two guys kind of humored me. I was nearly done anyway.

And that kind of truncated the conversation. I finished my briefing with the other two. They got up and left.

And I was told by the guy as he was walking out – that originally knocked on my door – that the next day to make myself available that evening to talk to some more people.

Well, apparently my briefing didn't go over too well because the next day nobody showed up, and the SAS conference was gone.

David: It was gone.

Corey: Just poof, gone.

David: So then you go home the day after you have this meeting, and what happens to you then?

Corey: I was feeling a little weird before I flew home, and I started coughing up this . . . While I was still here in Boulder, I started coughing up this really weird uniform black stuff. And there was a lot of it. It was really weird. Nothing like that had really ever happened to me.

Then I also, as I was being flown home, we did have a rapid descent, which I believe I had some sort of reverse altitude sickness that contributed to the situation.

But hours after I got home, I ended up in the emergency room. I started having all these weird pains in my body. My joints were aching, and I couldn't hardly breathe.

And what really concerned me is on my left shoulder, the joint really started hurting, and my chest started hurting, so I went to the hospital just to make sure I wasn't having a heart attack.

David: Wow!

Corey: They slapped an EEG on me real quick and figured out that I wasn't having a heart episode of any type. And then they put me back in the waiting room, and I left after a few people came in puking their guts out. So I kind of left against medical advice.

David: How did the briefings with Sigmund and his people continue after this initial event?

Obviously, it looks like somebody might have given you some kind of attack weapon. That's one interpretation of this. Did you talk to him about that?

Corey: Not to him. Ka'Aree did tell me that there was some sort of an attack that was orchestrated – something was most likely put in my food or water – and that she didn't think that it would have caused that large of an effect on me if I hadn't have been exhausted already.

David: Did you ask Sigmund about this?

Corey: It came up. He said that it had nothing to do with him, and that they were investigating it.

David: So what happens next in terms of briefings that Sigmund brings you to? Do you talk to others, and how does it go?

Corey: Yes. And I can't discuss the details of where it occurred, where these things occurred, but I was talking with anywhere from three . . . one, three, larger numbers of people – a total of about 28.

And I was giving the same briefing. Ka'Aree did not answer any of their questions in the further briefings. That kind of freaked the guy out a little bit.

David: Did she identify herself when she was talking through you?

Corey: She did, yeah.

David: Really? Okay. So that would have definitely been very uncomfortable for someone who's not comfortable with this.

Corey: A scientific person. Yeah, they were not happy at all with that part. But when I'm giving these briefings, I had 13 people out of 28 stand up, throw their arms in the air, and storm out saying basically the same thing, "I can't accept this."

David: Hmm.

Corey: And the other people that remained just kind of . . . almost like they thought they were being punked. They're looking around. Their heads jerking around looking at each other.

They've got these kind of stupid grins on their face. They were just having problems with the information. They were polite though.

But afterwards, they were telling their superiors, "What a waste of time. What a crazy story."

So since then, Sigmund has put a pause on briefings.

David: How much do these guys know? Do they know about the MIC group?

Corey: Yes.

David: Do they know about extraterrestrials? Do they know about Atlantis and Antarctica?

Corey: No, no, no.

David: Pre-Adamites?

Corey: No. They don't know any of that. They don't have a need to know. They're engineers. They just know about the programs they've dealt directly with.

And those usually don't go anywhere further than this MIC SSP group that was basically kickstarted during the Star Wars Initiative.

David: Have you had any further meetings with the SSP Alliance since we last did our updates?

Corey: Since I first met Sigmund, and Sigmund started this hunt for these SSP Alliance groups, they've been keeping their heads down. So the only person that was a part of the SSP Alliance that I've been meeting on a regular basis is Gonzales.

And he's been coming and picking me up in the Mayan craft.

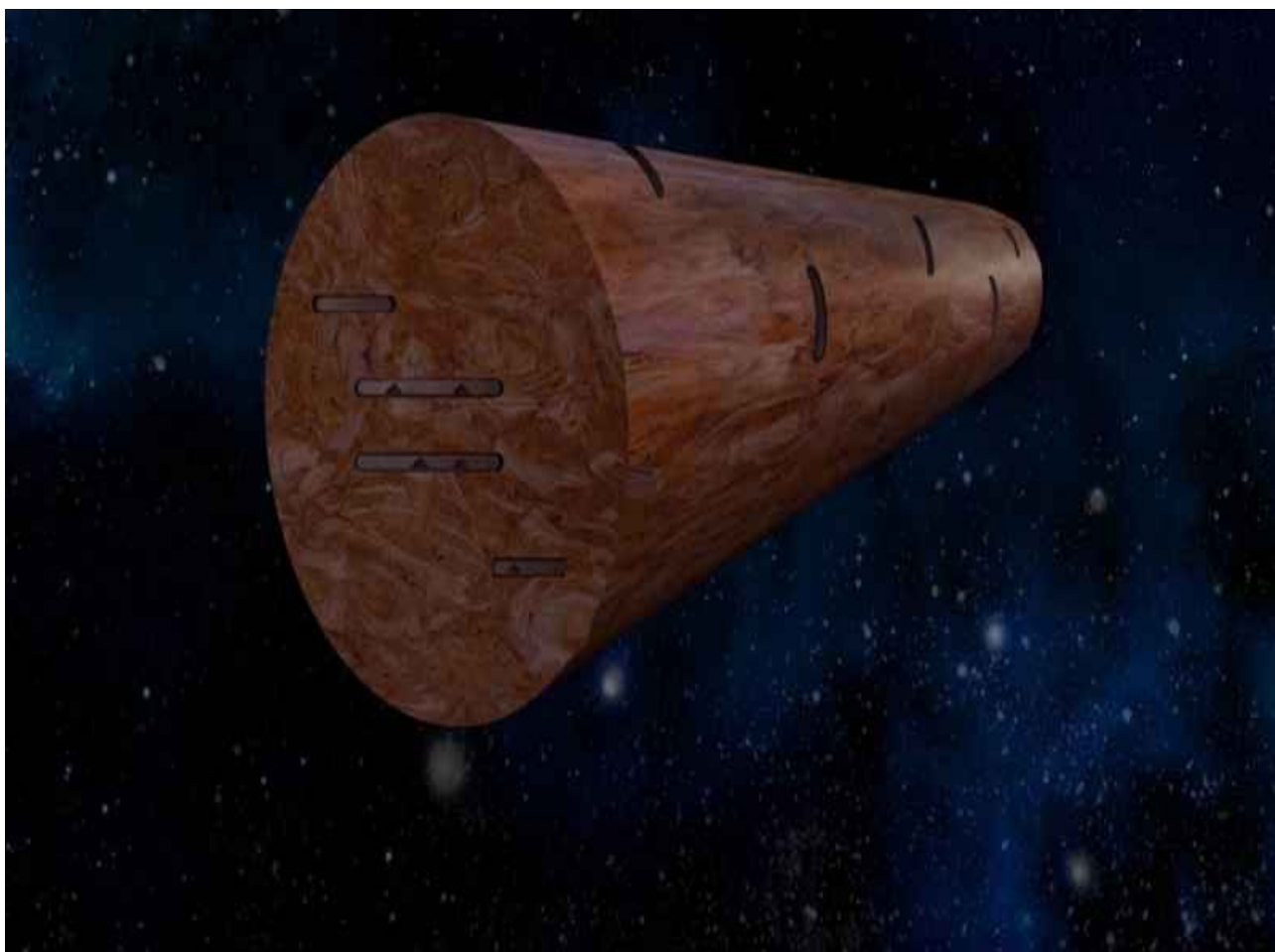

David: What's the reason for him showing up in that way?

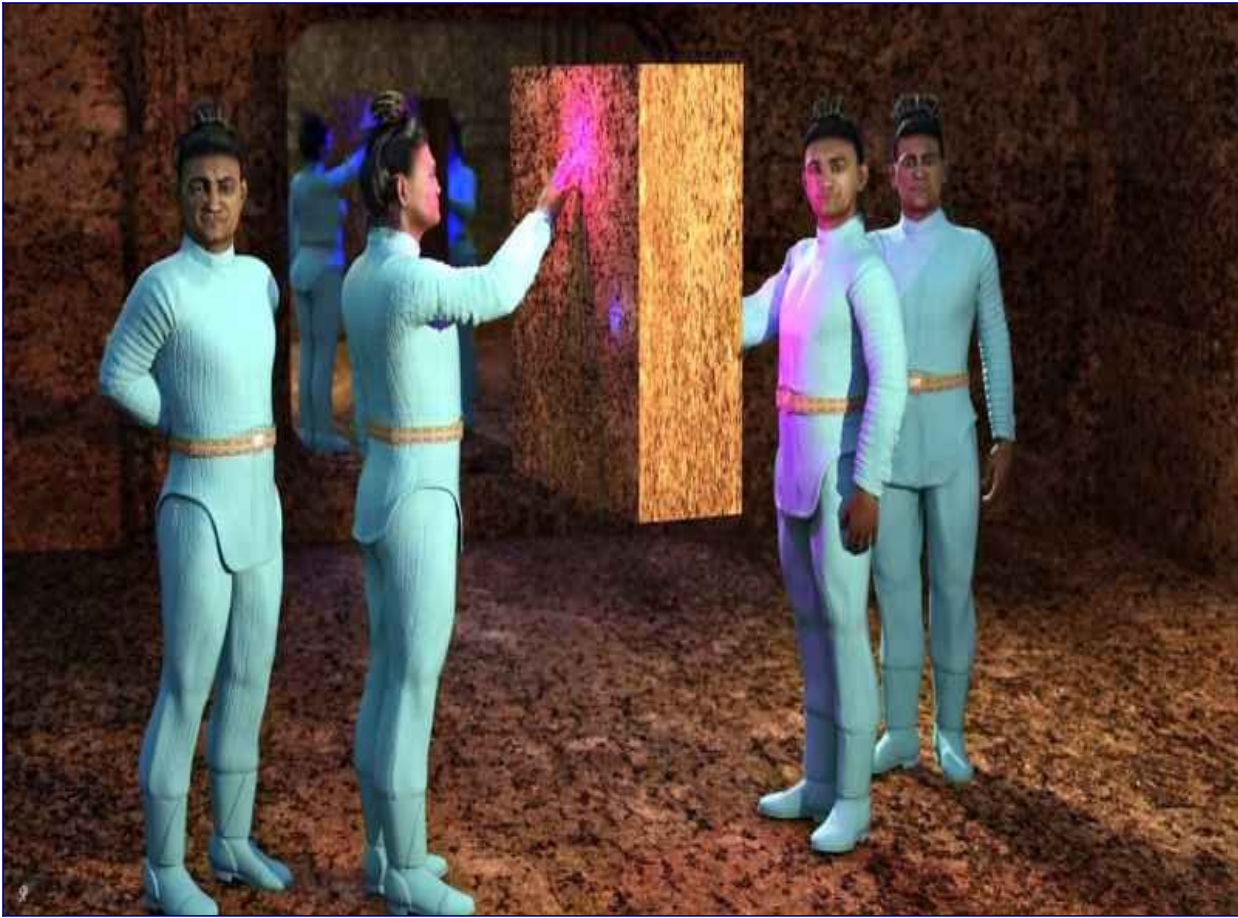

What was the objective of these meetings?

Corey: Well, since he's been staying with the Mayan people, I've been teleported to this giant stone craft somewhere out in orbit.

David: And what's going on? What's happening to you when you go up there?

Corey: I've been having some memory issues that concerned Gonzales. The last time I had reported I was up on the Mayan craft, and he had come up to me with this Magic 8 Ball-looking stone that he was scanning my head with, giving me concerned looks.

I've slowly started to find out what he was concerned about.

David: You had alluded to some big dark secret that has started to come up for you about your past that you found to be very upsetting that has very negative implications for your memory and your health.

Corey: Right. Many may recall that before I really started even talking to you, Gonzales – before I knew him – and the Mayans had appeared in my house after I'd had an eye surgery.

It was a detached retina surgery that the surgeon said was no different than astronauts' eye. It took three times to repair it. It was a very traumatic surgery.

I had some sort of a full memory recall that was very upsetting. I was basically almost suicidal at the time. And the Mayan group brought me up to this vessel and had suppressed a lot of memories that had popped back.

They also disassociated the, I guess, emotional energy I have tied to certain memories. When I try to talk about all of this, I would go into some sort of a panic attack.

The information that they hid away is causing some of my memory issues that I'm having.

He explained to me that he found out that I had done two other 20-and-Backs . . .

David: Really!

Corey: . . . that I have really no memory of. That was hard for me to accept. It was very upsetting.

And he has been working with me to help mitigate the issues on my memory from these other 20-and-Backs. The only thing is I've been having sort of a bleed through. I've been having dreams, and they've been pretty dark.

David: Does this mean that you have 20-and-Backs that were not Solar Warden at all?

Corey: I don't know what . . . I don't know the details of them yet. And I don't know if I'll . . . Hopefully, I don't want to process the information if it's as disturbing as what has been popping into my dreams.

David: Given that the Mayans seem to have very advanced technology, what method did they use to heal you of these horrible things that were coming back in your mind, and the damage that it was resulting in?

Corey: Right after the eye surgery, what they had done is they had further suppressed those two 20-and-Backs scenarios to where I would have no memory of them. And it had unintended consequences.

The way the mind compartmentalizes things, there was starting to be some bleed through. And there were some memories that were associated with my first 20-and-Back. So when they truncated those memories, there was something missing.

So my mind was trying to fix what was missing, and I started having memory issues and disturbing flashbacks.

So originally they had taken those memories and suppressed them further.

What they're doing right now is, I'm going up, and they're helping mitigate the issues. They have this free will thing. They won't totally fix different ailments of mine, but they are mitigating them so I can continue with this mission.

David: Have you had any other meetings with the Blue Avians, and, if so, what have they been telling you?

Corey: Yeah, I've had . . . The meetings with Tear-Eir have slowed down dramatically. And that's happened before. It's kind of been an ebb and flow as things are occurring.

David: Right.

Corey: And most recently, Tear-Eir has told me that we've entered into a very important three-year window as a species, that we're creating as a species the, I guess, reality that we're going to experience together.

That this three-year window is very important – how we, I guess, exert ourselves to try to get disclosure is very important.

It's very important to start doing things like mass meditations, anything that can kickstart that hundredth monkey effect within the rest of our subconsciousness.

David: The mention of three years is interesting because Jacob, one of the other guys who was a very, very knowledgeable space program insider, but wouldn't tell me everything he knows, as you and I both know who he is.

He spoke a lot about 2020. That was one of the key windows that he was always describing. And that's exactly what you're saying.

Corey: Yeah, 2020. Gonzales has made jokes about 20/20 vision and 2020 being an important part of this transition. So 2020 . . . There's some importance tied to it for sure.

David: Given the fact that Tear-Eir is being that specific, and that as we've talked about in many other episodes, we're expecting some kind of solar energy flash, this would imply that it's definitely not happening prior to 2020. Would you say that?

Corey: I'd agree.

David: Okay. But the window of 2020 to 2024, because you say they've also added a year on . . .

Corey: Yes.

David: Could you talk about that window? And what do you think might be going on with 2020 and that period of time?

Corey: I'm not sure what's going to occur, other than we're making some sort of a decision as a people in that time period. It's important.

A lot of these groups that are trying to massage and muddle things are kind of sitting back now. Pretty much, the ball's in our court.

How we're going to proceed from now on, a lot of it has to do with how we process this new information, and how we react to it.

David: There was a blueprint for partial disclosure that seemed pretty obvious.



Tom DeLonge, the multi-Grammy winning lead singer of Blink 182, arguably the biggest rock band of the 1990s, is saying that he met with 10 different military insiders. It came out in some of these WikiLeaks data dumps that actually verified that he was having meetings, and who he was meeting with.



And now he's got the second of his two books of the "Sekret Machines" series that gets into Nazi bell craft and all kinds of stuff, but basically seems like the MIC space program. What's going on with that initiative in light of all this stuff that you're now bringing to the surface?

Corey: They're, I guess, tacitly proceeding with this partial disclosure narrative, but at the same time, heavily investigating all of this new information, which could affect the plans for doing this partial disclosure of the MIC Secret Space Program.

David: Is there the same degree of support for the Tom DeLonge initiative now as there was before, or has that changed?

Corey: On the face, yes, they are proceeding, but many, especially in the control structure, they want to know the results of the investigation Sigmund's doing. They're very interested in this investigation.

David: The Vault 7 documents had a big build up for them going on where WikiLeaks was putting out all these cryptic tweets, and people were trying to figure out what was going on. There was a real big buzz.

And then it comes out in the open, and it's all about the CIA. And they're saying there's 8,700 documents in there.

What are we seeing with Vault 7, and can we expect more of that kind of stuff to happen?

Corey: Yes. I was officially told that this document or data dump that I talked about in the first couple of seasons of Cosmic Disclosure has finally started to occur in earnest.

That there were going to be further clusters of very uncomfortable information that are going to hit the Internet.

And as we have time to digest that, maybe even before we have time to fully digest that batch, another one would come. And then another one would come – with in between those, the Cabal doing a few tit for tat releases of data of their own, but nothing as significant as what the Alliance is leaking.

So we're in the beginning of this document dump, and there's a lot more coming.

David: Are we still expecting there to be some sort of new financial system once the dust settles? Might there be an economic collapse? What about that, just briefly?

Corey: I'm not seeing any information about an imminent collapse. It sounded like, until we have some sort of a disclosure, they are keeping everything stable.

So at a future point, there will more than likely be some sort of a change in the financial system since it's going to be exposed that the financial system that we have right now is completely corrupt.

David: When this financial change happens, what will the effect be for the average person?

Corey: A more level playing field. That's the goal. A more level playing field for all of these different nations to start interacting with each other. And hopefully, when we get to that point, we'll also have technologies that we'll be sharing with all of these other countries, which will bring us closer together and into a new era.

David: If these technologies do get declassified, have you gotten any evidence as to how that will take place?

In other words, are they going to be officially announced, or are they just going to start to bubble up, or how is it going to happen?

Corey: It's going to occur in the data dumps, more than likely. And then officials with egg on their face are going to either have to confirm or deny the existence. That is the information I have.

David: Well, I want to thank you [**Corey**] for continuing to fight the good fight. And I want to thank you [audience] for supporting us by watching this show and being subscribers.

I'm [David Wilcock](#). This is "Cosmic Disclosure", and I thank you for watching.

Cosmic Disclosure: Revealing the Original Secret Space Vehicles **with Mark McCandlish**

Season 7, Episode 18

David Wilcock: All right. Welcome back to “[Cosmic Disclosure](#)”. I hope you're having an amazing day, and maybe after you see this episode, it's going to become even more amazing. I'm here with **Corey Goode**, and we have a special guest today, **Mark McCandlish**, one of the original thirty-nine whistleblowers who came forward at the Disclosure Project event on May 9, 2001, at the National Press Club in Washington, D.C. to disclose the reality of the extraterrestrial presence on Earth.

|So, **Corey**, welcome to the show.

Corey Goode: Thank you.

David: All right. We're going to start now with an intro and overview of **Mark**, in his own words, from his background. Let's take a look.

* * * * *

MARK'S STORY

Mark McCandlish: My electronics aptitude was so high right out of high school that the Air Force was really enthusiastic about getting me to work on something like a weapons control system on aircraft. So that's where I wound up going.



After I got out of the Air Force, I used the GI Bill to go to Brigham Young University, studying design illustration. And then I went to Art Center College of Design as an automotive design major and eventually changed my major to just straight illustration when I began to see that the bottom was about to fall out of the automotive industry, and they weren't going to be hiring any designers in the late '70s, early '80s.

And that's when I went to work for the defense industry.

I had been approached by the Calabasas Division of Lockheed, and I think this was right at or right before the time that Lockheed joined with Martin Marietta and became Lockheed Martin.

And the gentleman that had asked me to prepare this illustration said that, "We can't tell you what it looks like. We can't tell you anything about the aircraft, only that it's the second generation in an existing family of extremely high speed, high altitude aircraft.

And so we need you to draw a picture of something that looks really fast.



So I looked around, and the two fastest aircraft that I was aware of at the time was, of course, the SR-71 Blackbird, which is Mach 3 , and then the prototype XB-70 Valkyrie that was built by Rockwell International's North American Aircraft Division.



So I combined features from those two aircraft, and I thought, this is a really cool-looking aircraft.

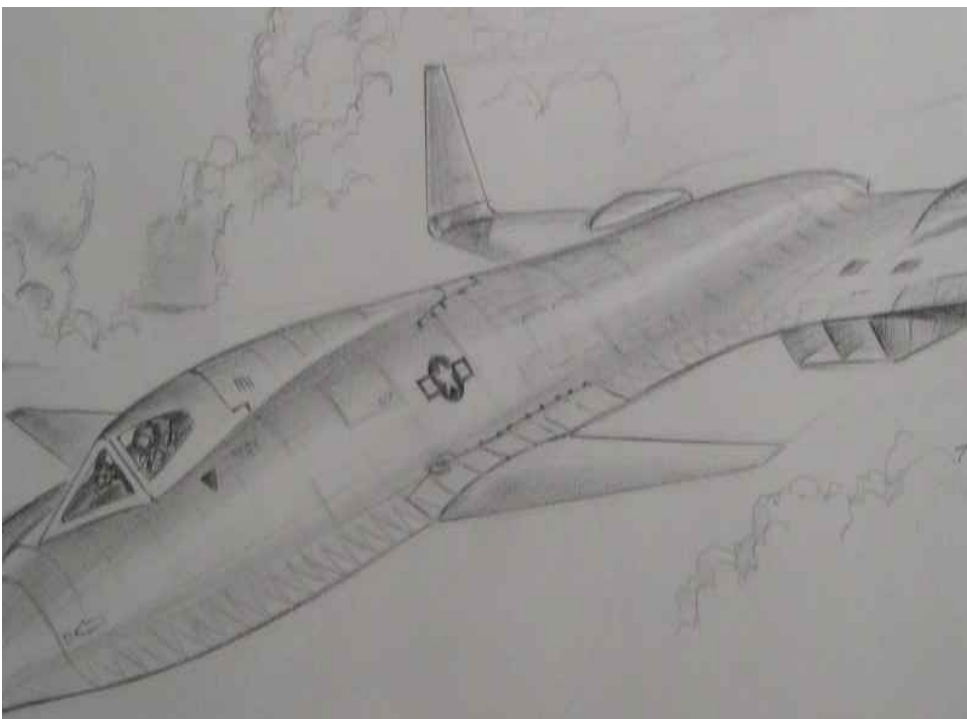

And I went in, and much to my surprise, they had a couple of engineers from Lockheed Skunk Works there.

And it was an order gentleman with glasses, a receding hairline. And they were actually wearing little white lab coats with the pocket protector and the slide rule and this kind of thing.

And so I opened up my sketchpad, and I turned around, and I slid it across this big, beautiful, mahogany table in this conference room.

And right away, I could see that something was wrong. The gentleman both took on an appearance of being kind of startled, like they were seeing something they weren't expecting.

And then one of the two gentlemen – the man with the glasses, the receding hairline – you could literally see his face turn red. You could see beads of sweat starting to form on his forehead and his lip. And his hands started to tremble.

And he slams his hand down on the notepad, and he says, “What are these canards, and what are these winglets out on the wings? Those would be torn off at Mach 17 . . .” And he stopped himself right there as he said “Mach 17”.

And I thought, “That's 12,000 miles an hour [19,300 kph]!”

And they were both upset. And they were upset in a way that, at first, I thought it was because I didn't do a good job, because the illustration didn't look credible.

And then I thought, “No, this is something else.” They're reacting because I've hit something. I've hit the nail right on the head with this illustration, and they may perceive that what I've done here is because of some kind of a leak – some kind of an information leak.

And so the first thing I did was I tried to assure them by saying, “Well, look, I'll be happy to illustrate whatever you want, but the fact is, I just don't know what your aircraft looks like because nobody's told me. They said they can't tell me. The design is classified. So what I've done here is I've combined most

of the most interesting features from these two aircraft – the two fastest aircraft that I know of – the SR-71 and the XB-70.”



And so then they kind of calmed down a little bit and relaxed. But at that point, the cat was already out of the bag. They'd said “Mach 17”.

It really pointed out to me that there were some programs that were going on. And, of course, you always assume that there's something classified going on all the time behind the scenes.

But as far as aircraft design was concerned, it really helped to illustrate that there were things going on – advanced projects – that were really pushing the envelope in terms of material use, high speed, high altitude and propulsion systems that had never been seen before – these supersonic combustion ramjet or scramjet engines.

And so it was an eye-opener. That's for sure. It let me know that there were other things out there that the general public didn't know about.

* * * * *

David: Okay. So what you see there is very interesting. Here's a guy who's describing having a direct one-on-one meeting with insiders from Lockheed Martin Skunk Works.

And they told him that canards and winglets on the plane would fall off at Mach 17. So clearly, he had access to the real deal.

Corey, what were your thoughts as you watched this clip?

Corey: It was pretty interesting. I had seen information about these early planes that they were developing, and they were very, extremely aerodynamic.

But when he was talking, for some reason – it popped in my mind – I remember a type of engineered crystal that they were using that they would put on the outside of these craft that . . . You know, like piezoelectric crystals. If you hit them, they'll give off an electrical charge?

David: Yeah, sure.

Corey: These convert friction heat into electric charges.

David: Oh, that makes sense.

Corey: And then the skin of the plane would have this crystalline material painted over it. And then the heat would be turned into electricity. The electricity would transfer through the skin of the plane into something that would quickly store the electricity. So it would be kind of like a heat sink.

It would be pulling electricity very quickly, and heat couldn't build up.

David: Well, let me just mention that there are known things called photo cells, which we already have in electronics, where they can sense a light source and actually convert that light to electricity.

So this idea of basically what you're describing as a thermal couple on the outside of the plane, that's totally plausible within electronics that that could work. I just never thought of it before. It's fascinating.

Corey: Right. I'd forgotten about it, too. It just popped in my head when I was watching that clip.

David: So Mach 17, . . . of course, some of the people watching this may not be aware that conventional aeronautics . . . even Mach 4, Mach 5, is considered extraordinary.

What are the speeds that you encountered with some of the craft that are in the classified world that he got a little taste of here?

Corey: Well, yeah, there was a lot of talk of craft that were being developed between Mach 9 and Mach 20 . . .

David: Right.

Corey: . . . that were being developed that were mostly for flying in the atmosphere – test craft to get to a point where they could develop craft that could fly in and out of the atmosphere.

David: So is it normal for somebody like **Mark McCandlish** to have this background of industrial design – he said that he majored, at first, in drawing automobiles and getting really nice technical illustrations of them, and then in his case, going into the defense industry – that a guy with those skills could end up potentially in some kind of classified program?

Corey: Absolutely. They need people of all skill sets. You're going to run across a lot of draftsmen, artists, that worked for the government that have a lot of knowledge like he does.

David: Now, another thing that is interesting to me was he mentions Brigham Young University. And **Pete**, tongue-in-cheek, called that whole area – Utah, Idaho, etc. - “Mormania”. And it was originally a joke, but apparently, on the inside, they now actually use that term – that what I've heard from him – and I want to get your thoughts on this – is that many people who worked for the CIA and other intelligence agencies are recruited from Mormon states in America, that there is a Mormon component to the black ops world.

So I'm curious if you ever heard anything about that?

Corey: Yes. I read on the smart glass pad about how different Mormon groups were creating vaults underground and were reporting back to the intelligence agencies that they were encountering beings when they were trying to build their facilities underground.

David: Beings that were not human?

Corey: Correct.

David: When we see a guy like **McCandlish** coming out and talking about this, what do you think he had to gain from this? In other words, I don't see any evidence. I don't think he's ever written a book.

He kind of went off the radar after Disclosure Project in 2001. Now here it is, 16 years later, he pops up again.

So do you think that there's any self-interest or manipulation going on here? What's his objective?

Corey: One of the things you see quite often with whistleblowers is that in the process of being a whistleblower, they end up losing their careers. And he pretty much lost his career within all of the defense industry and basically was in hiding for a while from what I hear.

David: All right. We're going to now continue with some more footage for you to check out. This is the second part of our groundbreaking interview with **Mark McCandlish**. Let's check it out.

* * * * *

COVERT CRAFT

Mark McCandlish: Well, this is a story that came to me through another aviation artist that . . . One of my contemporaries met this fellow and a friend of his at an air show at the old Chino Air Base where they brought a lot of the aircraft after the Second World War to be demolished and scrapped for their aluminum and so forth.

And he was saying that this fellow had a friend who was a former astronaut – it was one of the Buzz astronauts, Buzz Aldrin or Buzz Carpenter – one of these gentlemen.

And this individual was flying a Learjet, ferrying it from one location to another, and he was passing over North Central Nevada at the time – broken clouds and this kind of thing.

And he comes out of some clouds and into an open air space, and below him and to the left is this black aircraft that looks sort of like a flattened-out football shape.



And on the back end of it, it has not only a vertical stabilizer or a tail on the top, but there was another one down below.

A lot of people don't know that the early A-12 version of the SR-71 Blackbird also had the same feature. It had a folding vertical stabilizer on the ventral surface on the underside of the aircraft.

But this aircraft had an unusual inlet design. It wasn't the typical thing where you have a big hole hanging down underneath the wing where the air for the engine comes in.

This thing had, what looked like, a pair of these triangular-shaped NACA ducts near the leading edge of this.

There were no wings, no tail feathers – nothing. It was just sort of a lifting body design, like a flattened-out football shape.

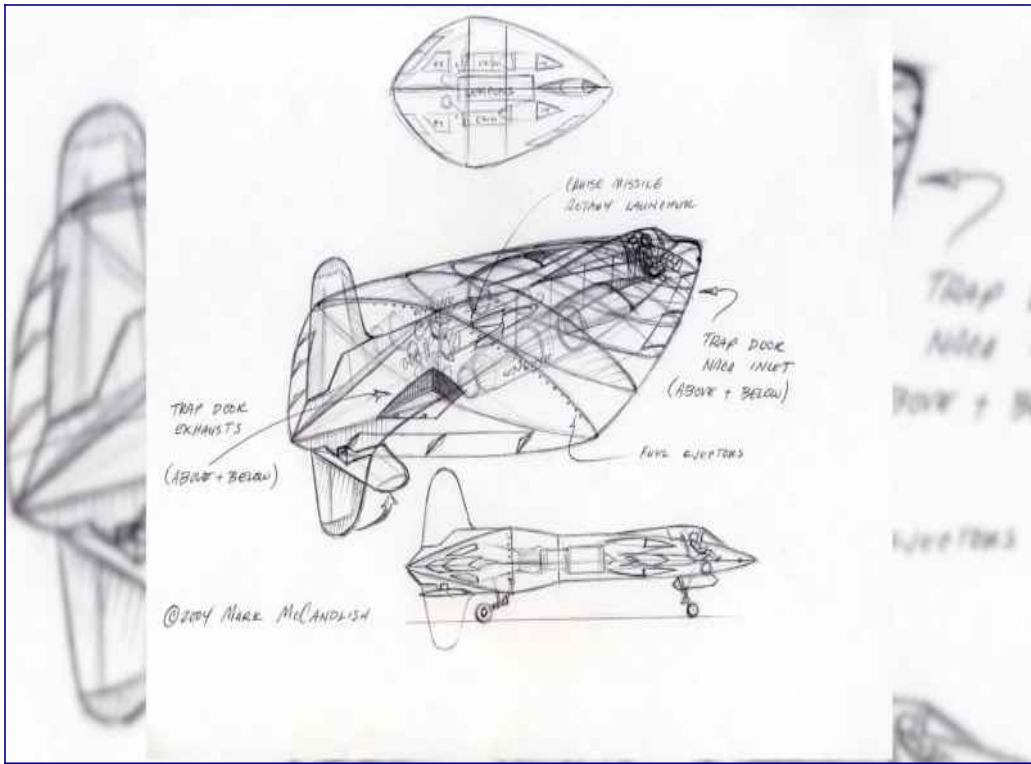

Control surfaces along the leading edges and on the trailing edges, but the inlets were a pair of NACA ducts.



And then at the back end were a pair of trapezoid-shaped exhaust ports. But then at the midsection, the widest part of this platform, was a ridge. And along the trailing edge of the ridge were what appeared to

be a number of fuel injectors pointing outward where it was obvious at some point in the flight regime of the aircraft, there would be something expelled from those ports.

And it was actually operating kind of like the whole back end of the aircraft was a linear aerospike engine, which has that kind of a configuration.

The pilot is there, and he looks at this plane and realizes that if he hadn't seen it directly that he might have collided with it in the clouds.

And so he gets ahold of the ground control operator for that region, and he says, "Why didn't you inform me that there was another aircraft in my vicinity?"

And he said, "Well . . ." The response was, ". . . because there isn't any. We don't have anything on radar at all."

And he says, "Well, the hell there isn't." He says, "I'm looking at a plane right now. It's black. It has the two tails." He described what he was seeing, "I'm in his 5 o'clock position."

And there's a long silence on the radio.

And then all of a sudden, he can see in the window, the cockpit – it's kind of like the X-15 cockpit where it's mostly aircraft with just a little tiny window and a splitter in the front. And he sees the face of the pilot look around at him like this, and like, "Oh, crap!", and banks away and goes into one of the clouds and disappears.

So a little while later, there's another voice that comes onto the radio – a deeper voice, a more serious voice, and he says, "Okay, pilot zone, so you need to change your heading and come in to Nellis Air Force Base, and we need you to land there and be debriefed. And I want you to roll out and stay at the end of the runway. You will be met at the end of the runway."

And so then they take him in, and they put him through interrogation and make it real clear that what he saw was something that doesn't officially exist, and he's not to talk about it.

But eventually, apparently, he did tell someone, including this colleague of mine who shared the story with me.

* * * * *

David: The first thing I thought of when he said a 'squashed football' was your description of the Dark Fleet craft which you said have a dark teardrop-type of shape.

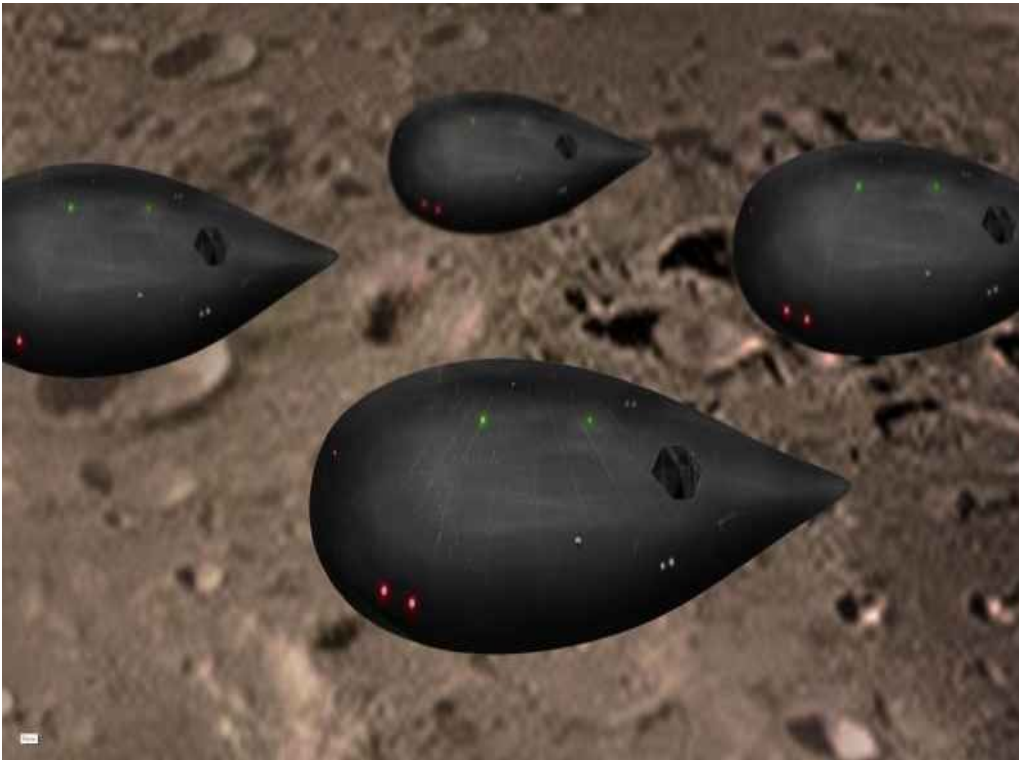

Corey: Right.

David: But based on the illustration that **McCandlish** made here, is that what we're looking at, or is this something else?

Corey: I knew immediately, the way he was describing the craft with the two fins, the two stabilizers, that it was a test craft from the military. I've read before about these vertical stabilizers, that are on the top and bottom, that, at a certain stage in flight, the bottom one drops to give them further stabilization.

David: Well, he had the location right, because he said this witness saw this over Nevada.

Corey: Right.

David: So there you go. That's your Area 51.

Corey: Right. That's a good place to see test craft.

I've received quite a few emails from pilots, that don't want to go public because of their jobs, that have described seeing very similar things.

David: Really?

Corey: Yeah.

David: One of the insiders that I have had contact with – I met through **Pete** Peterson – he claims to have been able to build eight different types of anti-gravity device. And he worked on aerospace design.

He has described that a lot of times these planes were built, and then they were mothballed. And he believed that the purpose was money laundering – that the plane was said to cost much more than it really did. It justifies these budgets.

The actual money spent on it might be much less, and then the less of the money goes to some other thing. Have you heard of that, and if so, where's the money going?

Corey: Yes. A lot of these contracting companies are . . . I mean, everyone's heard about \$200 hammers, \$300 toilet seats . . .

David: Right.

Corey: . . . that kind of thing. That occurs all the time to bring in extra money for black budgets. So that's fairly common.

David: What might some of those black budgets be? I mean, wouldn't this plane be the goal . . .

Corey: Right.

David: . . . or would it be something else?

Corey: Something like this probably came from a budget from a craft or something they were building that was known. And then they overcharged for that craft . . .

David: Right.

Corey: . . . and funneled that money into a craft like this. And a lot of times they'll build these craft. They'll put millions of dollars into building a craft like this just to prove a certain concept for future craft that they'll fly around a few times, and then they mothball them or take them apart.

David: Right. So given the design and the shape of this particular craft, what type of usefulness to you think it might have?

Corey: I think they were trying to increase stabilized flight past Mach 3 to 5, most likely.

David: It doesn't really look like it would capture air like a wing. Do you think there's some sort of anti-gravity component to how this works?

Corey: No. This is a conventional jet. It's just really advanced technology. It's kind of like what he was talking about – sort of like a ramjet. It brings in the air at the wings and expels the gases and air out the back to propel it.

David: All right. Next, we have another very interesting and strange story from **Mark McCandlish**, which I'm sure you're going to like. Let's check it out.

* * * * *

SURPRISING TECHNOLOGY

Mark McCandlish: There was a gentleman, and I don't remember where he was located, but he had a custom of jogging early in the morning with his dog. And one of the challenges that he made for himself was he would jog on this path that would go up to the top of this hill near the town where they had the city water supply. It was a big tower.

And it was a heavily wooded area with a clearing around the tower itself.

And as they're jogging up the hill, he comes out into the clearing where the tower is, and here is this aircraft. And it looks like a conventional jet aircraft standing on its tail, and it's orbiting this water tower silently.

No jet engine noise, no dust being kicked up or anything, and the pilot is just sort of playing.

And he's just standing there with his mouth hanging open, and his dog is barking and really going crazy.



And while the pilot's doing this, he kind of looks over his shoulder, and he sees the jogger there. “Oh, no!”



So he lights up the after burner, and off he goes using conventional power.

So it just pointed out that there must be some other things that they're incorporating and folding into some of the . . . maybe even the standard issue aircraft that are giving them abilities that are not completely obvious when looking at them from the outside.

* * * * *

David: This is one of those stories that seems to stretch the credulity a little bit. What is your feeling about the idea that conventional aircraft might have some sort of anti-gravity that would allow them to do those types of tricks?

Corey: Well, it's definitely not something that would be standard issue on one of the fleets right now out to sea.

David: Right.

Corey: But they have retrofitted conventional-looking craft with anti-gravity for specific reasons to be used, I guess, for special missions. It's not something that a lot of the different lieutenant commanders out there in the Navy that fly jets . . . they're not going to have this or know about this type of technology being incorporated into conventional craft. But it is something I've heard of. I haven't seen it with my own eyes.

David: I've also had Peterson tell me that military aircraft are all now – or at least many of them – are equipped with a technology that he called 'masking'. Are you familiar with that and what that's all about?

Corey: Yeah, masking is a common term. It just means 'camouflage'. It's an electronic camouflage.

David: So would a masked craft still be visible once the masking is turned on?

Corey: No. No.

David: Right.

Corey: That's the whole point of it. It pretty much . . . You're seeing what's behind the craft.

David: So what would the usefulness be of a pilot able to back the tail of a plane down and then turn circles around a tower like that?

Corey: That's not really the point. The point is to be able to loiter and hover to engage targets like a helicopter would and then having the supersonic flight capabilities as well.

It's one of the reasons also they developed the Harrier.

David: Sure.

Corey: Then you have the vertical takeoff and landing capabilities as well.

David: Now do you think it's possible, given that he seemed to have been turning circles around a tower, that the anti-gravity, in some way, was able to partially attach to the mass of the tower and use it as a center of balance or a pivot point for him?

Corey: No. Most likely what occurred is . . . They have a lot of this smart flight technology in drones now. And it's usually a camera that has intelligent computers connected to it.

The camera acts like an eye, focuses on like a tower, and then it will loiter and hover around a certain object.

David: Ah. So this could have all been done automatically. He was just having fun.

Corey: Right.

David: He doesn't have to do any fancy flying at all.

Corey: Yes. It looked like he took a little time out of a normal test flight to play around a little bit on his own.

David: All right. Now we're going to see a very interesting section of this interview where **McCandlish** is describing a UFO sighting that actually led to photographic evidence. Let's take a look.

* * * * *

THE CEDARVILLE UFO

Mark McCandlish: It was a fellow that I knew – his name was Arthur Reed – who took this photograph in 1982. He was just exploring northern California by car.

He was driving somewhere about 10 miles north of Cedarville, and he saw a large group of people that had pulled off the road, and they were all sort of looking off to the west.

And so he, just out of curiosity, stopped to see what it was. And off in the distance was this immense, black thing – big, large, V-shaped vehicle.



And the shape of it was what kind of gave it away as the possible product of Lockheed Skunk Works, because it had the same sort of faceted flat surfaces like a Stealth Fire.



The craft looked an awful lot like a large black V, and in the middle of each of those two wings, or legs, or whatever you want to call them, which were really thick and not aerodynamic in any way, shape or form, but there was a large white sphere.

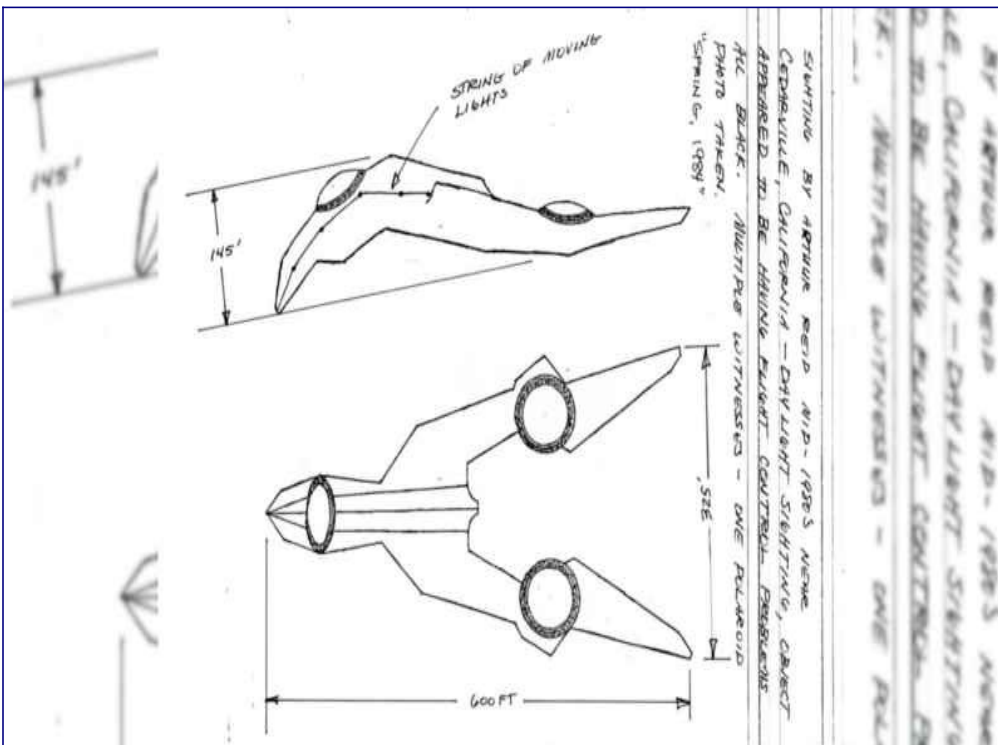

And then there was one up in the very front where they kind of came together. And there were seams on the surface of the thing that looked like the different parts of the vehicle could be articulated and folded up into almost a triangular shape.

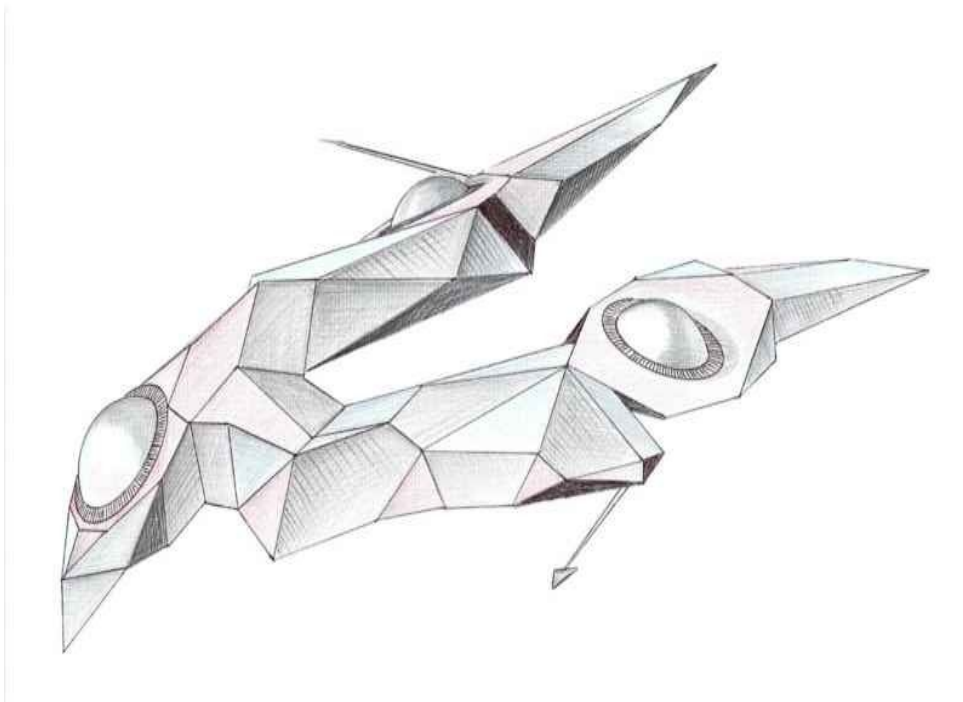

There were a series of red lights that went from the nose back towards part of the fuselage where the wings joined together.

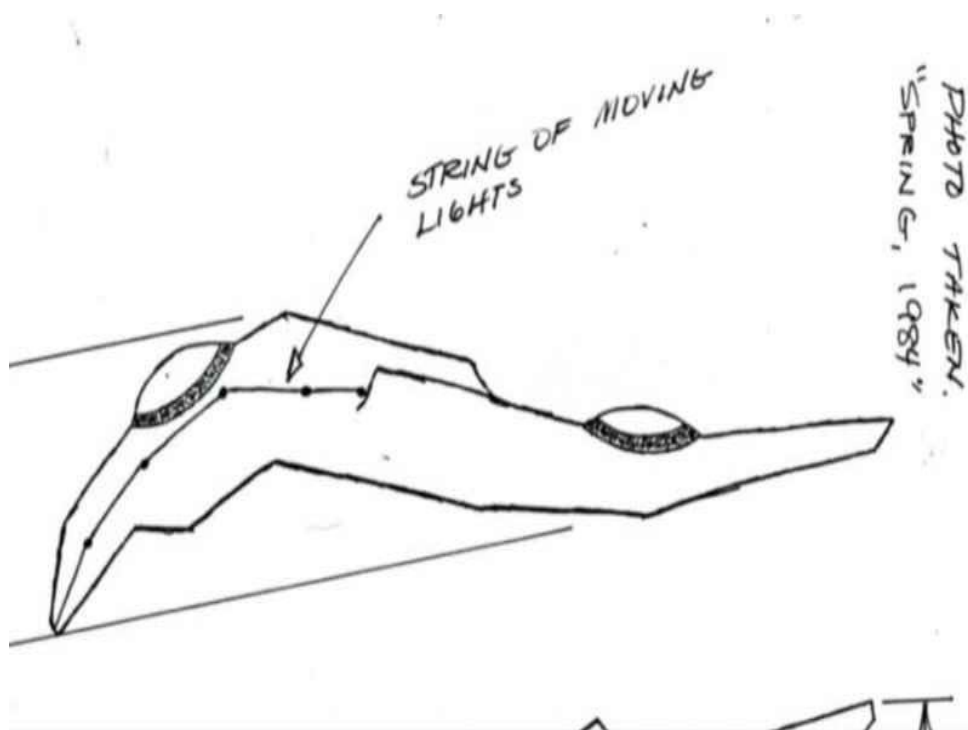

And the thing was in a nose down, bank to the left, and it was hovering in this position about maybe 250 feet off the ground.



And it was maybe a quarter of a mile to a half a mile off the roadway.

Very large. He said that he thought that this thing was somewhere between 300 and 600 feet on a side. It was that big.

He said that it was making this low, pulsating, humming sound, almost like something you'd see in a science fiction movie, sort of this [whirring sound] kind of sound. But he said it was so powerful, so loud, that you could feel it in your chest – that your chest would kind of vibrate and resonate with the sound.

And the people that were there that had pulled off the road represented kind of like a cross-section of what you'd find in America – the deeply religious people that are crying and on their knees, praying to God to deliver them from this chariot of the devil.

There were other people who were running towards it and waving and saying, “Take me for a ride”. And there were other people there hooting and hollering like they were watching a fireworks show on

the 4th of July.

In the photograph, in the foreground, you can see people standing in the bed of their truck, and you're seeing them all from the back, so you can't tell exactly what they're doing. But a lot of them, their arms are like this [up in front of his eyes], like they're watching it through field glasses.

There are other people just sort of standing around, just taking it all in, watching everything.

But he said that this thing sat there for the better part of a half an hour, and that's why there were so many people that had pulled off and were watching.

And apparently, there was some kind of a flight control issue with this thing, and it had initiated a bank, and then they couldn't pull out of this dive, so they just stopped. And it was hovered in this banked, nose-down position.



And so apparently, whoever was working on this thing was not able to repair that particular problem. And so the way they resolved it was this thing continued in its bank. I have to turn my hand the other way to do it right, but imagine that this [his hand is now face up and he's pointing to his palm] is the upper surface like this.

So the thing flips end over end like this [the top rising up and back], but at the same time, it continues the roll. So it goes like this [it first rolled to the right and then the nose twisted up and back], and it's pointed up and away from the crowd.

It starts to climb out slowly, getting louder and louder, and then it gets to about 5,000 feet and [hands slap together] gone just like that, out into space.

But he said he went back about a week later, and he parked his car in the same spot. And he was walking out to see if maybe there was any evidence on the ground that this thing had been there. Maybe something got dropped off of it, or maybe there was crop circle-type evidence – that kind of thing.

This Air Force truck comes rolling up – the dark blue with the yellow stencil on the side - “United States Air Force”. And a couple of military cops tell him he needs to get out of there and leave immediately, or they're going to arrest him, and they're going to impound his car. So he leaves.

* * * * *

David: Well, isn't it cool to have some really good illustrations – a guy that can back up his story with visuals like this?

Corey: And a photo – an actual photo.

David: Yeah. That's a very interesting and bizarre-looking craft. Let's just start by getting your thoughts as to, have you seen anything like that? What do you think its purpose might be? Is it just experimental? Was it actually used in operations, etc.?

Corey: I saw a lot of experimental craft, and a lot of them did say “Lockheed” on them, and they were faceted. And some of them were . . . I don't know how to . . . You could manipulate or articulate different areas of the craft. So this sounds to me like it might have been one of their test craft, a concept craft.

David: So when you say 'manipulate' or 'articulate', you mean the craft can move . . .

Corey: Change configurations.

David: Shapeshift, basically.

Corey: Right.

David: What would be the value of something like that?

Corey: Well, if you have three different points that are being used, I guess, as like impulse-type engines – electrogravitic engines – usually, they have them on a type of a gimbal that you can manipulate them, turn them this way, and then pull you in that direction.

So that's going to be kind of the same concept. And most of these that I read about were remotely controlled – the test craft. They didn't necessarily have pilots.

David: Well, I'm thinking about the old James Bond movie where he's got the car, and he drives it into the water, and then things all start shifting. And now that it's in water, it's got fins instead of tires.

Corey: Right.

David: Or it becomes a jet, and it flies, and wings come out. Is it possible that the shapeshifting has something to do with where it's traveling, like if it's in atmosphere or in space or something like that?

Corey: I would think it mostly has to do with controlling the attitude and pitch and yaw of the plane.

David: Just the actual manipulation.

Corey: Right.

David: Is it normal for people to be able to see one of these, or was this some kind of an accident that took place?

Corey: I think he described what most likely happened very well.

David: Right.

Corey: There was some sort of computer glitch, or they weren't able to communicate with the craft, and it went into a loiter position. It was most likely programmed to go into a loiter position if there was an issue.

David: Now, earlier in this same episode, he was talking about how craft that are going to travel at Mach 17, that he couldn't have these canards and winglets on the craft because they would get torn off.

The thing that strikes me is, you're talking about a craft that has moving parts – a craft that has all these facets on it. It's got an unusual shape.

Wouldn't that type of a structure stress out under very high velocity and not be a good choice for a high speed aircraft?

Corey: No. Most . . . A lot of them are faceted – the craft that are supersonic.

David: Okay.

Corey: That's actually a part of the design. It's not only for deflecting radar, but they design them to be highly aerodynamic.

And I didn't see anything that would cause a whole lot of drag on that craft.

David: But the joints . . . In order to have the joints be strong enough that things could move and then hold up under that velocity . . .

Corey: Most likely it moves into a different configuration.

David: Oh, for high speed?

Corey: For high speed. Right.

David: That, I can understand. So maybe the two Y-like sides of it would pull together.

Corey: Come together. Right. Right.

David: You mentioned before that the ICC – the Interplanetary Corporate Conglomerate – within the greater space program you were part of, was manufacturing and selling technology to over 900 extraterrestrial groups – 900 being the ones they were in regular contact with.

Would the ICC be testing anything on Earth, or would this be some other group besides them?

Corey: Well, the ICC controls a lot of these military-industrial-complex-type firms that contract this stuff. So they're going to be overseeing it anyway and pulling in technology that they see that can be incorporated into higher technology craft.

There's most likely an Area 51-type of Lockheed-Martin joint effort.

David: How might you use a craft like this? What would be its purpose? Is it an attack weapon?

Corey: Yeah. It probably has different weapons-platform packages you can put on it for reconnaissance and also weapons platform to make it a weapons platform. But most likely, that was a concept for another craft that . . . They'll build three or four different concept craft to finally come up with one final version.

So that could have just been part of a process of creating another craft.

David: Well, that's all the time we have for in this episode of “[Cosmic Disclosure](#)”. I'm here with **Corey Goode**, and we are watching the very surprising testimony of one of the original Disclosure Project 39 whistleblowers, none other than **Mark McCandlish**. We'll see you next time.

[Cosmic Disclosure: Antarctica: The New Area 51](#)

Season 7, Episode 19

[David Wilcock](#): All right. Welcome to “[Cosmic Disclosure](#)”. I'm your host, **[David Wilcock](#)**. I'm here with **Corey Goode**. **Corey**, welcome to the show.

Corey Goode: Thank you.

David: Everybody is talking about Antarctica, and your information is that there is a very interesting new finding or series of findings down there, and the more that this goes on, the more you've learned.

So tell us what's new in this whole Antarctica story that we haven't already been covering?

Corey: Well, some of the newest information that I received is information that's going to make some of the military-industrial complex a little nervous.

It turns out that during the 1950s, there was a project called Project Ice Worm, and they were basically in icecaps building launch silos.

This particular one that we have video of occurred in Greenland. Now what's significant about this is that they've used this method of creating under-ice bases all through Antarctica.



They've created mini-bases, but much larger, that have become R&D bases. And these research and development bases are where companies like Lockheed Martin are doing reverse engineering of a lot of the technology they have found under the ice.

This is also how they built some of the early Moon bases and Mars bases – very similar – in a very similar fashion.



David: So you're saying that Lockheed Martin and other groups have bases in Antarctica that are more extensive than what we were led to believe or what you were led to believe in earlier briefings?

Corey: Correct, but what's significant about talking about this publicly is that, I believe in 1959, an Antarctic Treaty was signed.

And in that treaty it was stated that no weapons of war would be developed or used on that continent.

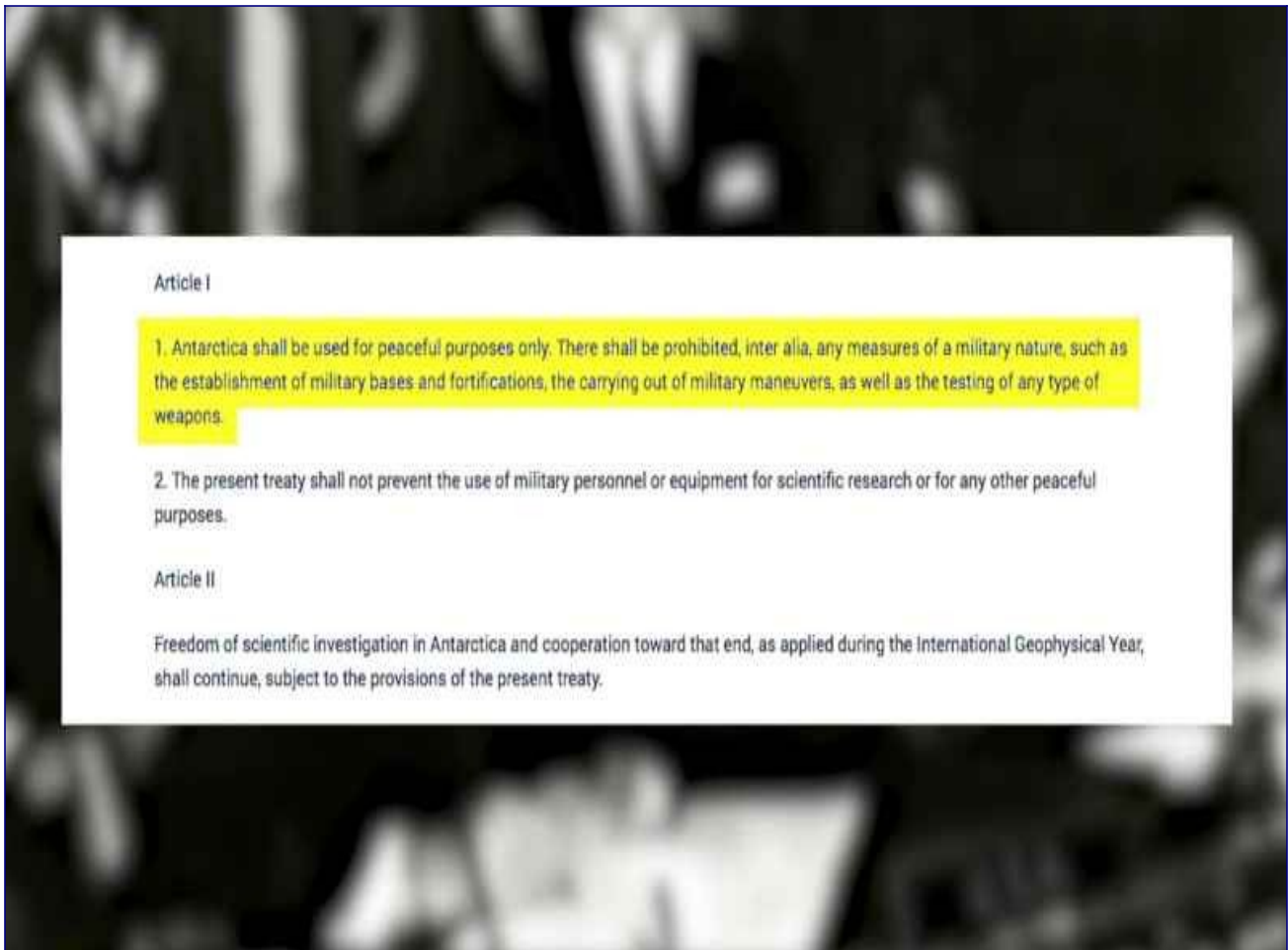

It would be used for peaceful purposes only.

David: Yeah, there actually was something called International Geophysical Year 1959, IGY 1959, and that was when all these things were codified.

Corey: Correct.

David: And that's also when they mapped out what Antarctica looked like under the ice, and you found out that there is a continent with land down there.

Corey: Right, twice the size of the continental United States.

David: Right. So if they are developing weapons systems that contravene an international treaty that's been in place for over 50 years, how does that affect people's perceptions of these defense contractors once this comes out?

Corey: That aside, the scariest thing is that some of the Alliance groups . . . If this information gets out in the public, they will have full reason to set up a blockade – it would be similar to the Cuban Missile Crisis – to set up a blockade of a certain area of Antarctica, and they would try to force these groups to show what's going on inside these R&D bases.

Now, some other interesting information is that they have what they . . . They're referring to this as a part of an Antarctic Area 51.

There is also a very large former Nazi base that was turned over to the military-industrial complex, if you want to say that, more like the shadow government.

And this former German base was used as a secret space program port. It is now a major port – spaceport – for this shadow government.

They use it to fly in and out of the atmosphere all the time. And a lot of these craft will service some of these space stations or fly beyond.

David: We did cover this in another episode, but I'd like to ask you again for this one. What would be the tactical or strategic significance of having a big spaceport in Antarctica? It seems like it's an inconvenient place to travel to.

Corey: Well, it is, but the electromagnetics you have to deal with from the atmosphere and the gravitational field is more conducive, even though they're using antigravity craft.

A lot of the times, when they fire rockets, they try to fire them close to the equator . . .

David: Right.

Corey: . . . for certain purposes. And also, if you're flying a bunch of classified craft in and out of the atmosphere on a regular basis, you know, Area 51, or out in Nevada or Arizona, those places aren't going to cut it. You're going to want a place where you have complete control, and it's very hard for prying eyes to see what's going on.

David: When you mentioned the Earth's electromagnetic field, what is it about the South Pole that makes that more conducive to a launch?

Corey: I guess there's less of the Van Allen Belt effect going on.

David: Okay. There was a very interesting episode of Ancient Aliens, and in this episode they had Linda Moulton Howe, who has a show on Gaia, giving a very interesting insider testimony about a man who was a pilot and who flew in a restricted area and saw a gigantic hole in the ice over Antarctica, and said that craft were coming and going from it.

What does that have to do, if anything, with what you're hearing about what's going on in Antarctica?

Corey: I'm told this area was very close to the spaceport. So, yeah, that is VERY significant, but what also is significant is that he was flying . . . the reason he saw this hole . . . it was in a restricted airspace. He flew over it because it was an emergency, and they were picking up – I can't remember how many – scientists that had disappeared for about two weeks.

And you don't disappear for two weeks in Antarctica and survive unless you have cover and supplies. So these scientists that he picked up were petrified. They'd obviously been told not to talk to anyone. They wouldn't say a word the whole time they flew back to where they were being cared for.

David: You had mentioned in updates that you recently put out that there was something about the gases having to do with why this hole is there. So could you talk about why is there a hole in the ice, and how does that factor in with the excavations that are going on now?

Corey: Right. There are more than one of these holes, and they're natural. They occurred mostly natural. They're geothermal vents.

It appears that what's occurring is that the continent is heating up under the ice. There's a lot of geothermal activity going on that's causing the under-ice lakes to significantly heat up and it's heating

up the ice shelf itself.

Now what this is doing is it's causing the ice to start to melt at a quicker rate. So these . . . It's a geothermal ice vent, and they have widened it for their purposes of flying in and out, and also using it as a way to vent out all of the heat that they're creating with their excavations.

David: Could they be using that heated air to potentially channel it, much like you would steer a river with irrigation projects?

Corey: No. They're trying to vent out as much of the heat as they can, because it is destabilizing these ice caverns that they've created.

You have to understand that the ice is moving at about a foot a day. And they're at a stationary point under the ice.

So not only are they excavating in this direction [**Corey** moves his hand in one direction outward] to uncover new artifacts, but they have to constantly excavate in this direction [**Corey** moves his hand to the opposite side] as the ice flow occurs.

This is compounding the thermal issues that are going on, because we're using different types of steam pressure to excavate, and when that melts the snow, it causes under-ice rivers, and that's further lubricating the ice shelf. So there are some significant issues that it can cause.

If they continue what they're doing and this ice shelf were to break off and fall into the water, it could cause tsunamis and other obvious problems.

David: It was interesting that in January, all of a sudden, there were news items in the mainstream media in which all these people were being evacuated from some of the main bases in Antarctica, and the story was that there was a big crack, and they were fearing that it could break off into the sea.



A Giant Ice Crack Is Forcing the Evacuation of the Halley Antarctic Research Station

A new threat emerges.

PETER DOCKRILL 17 JAN 2017



Scientists are being forced to evacuate the Halley VI Research Station in East Antarctica after a huge crack in the ice nearby doubled in length in less than three months.

The move comes only weeks after the facility began relocating in response to another threat: a huge chasm opening to the south, which threatened to cut the station off from the rest of the shelf and cast it adrift.

AP - January 18, 2017, 3:41 PM

Huge ice crack in Antarctica forces British scientists to flee research station



An iceberg surrounded by sea ice in Antarctica. EVA NOWATZKI, DISTRIBUTED VIA IMAGGEO.EGU.EU

19 Comments / f Share / t Tweet / Stumble / @ Email

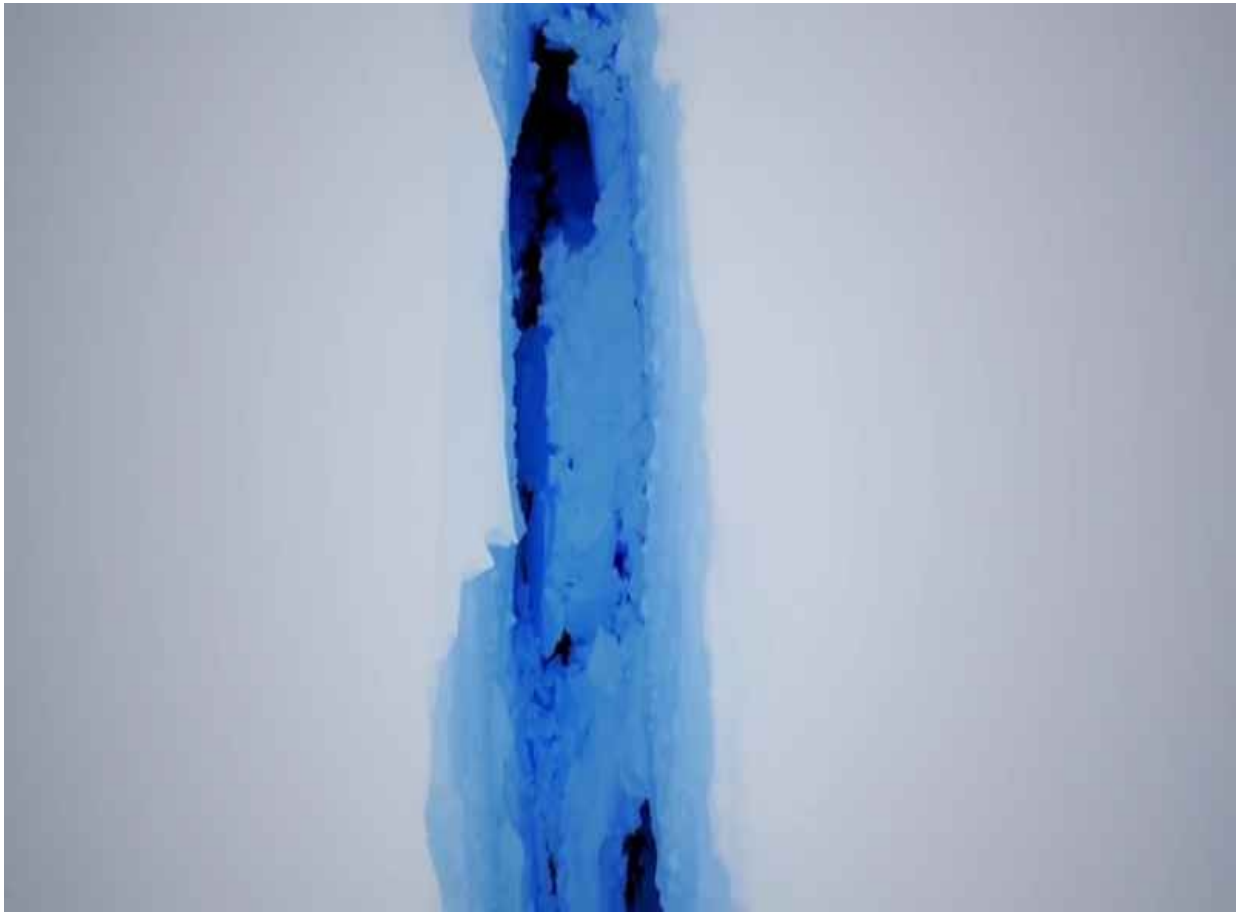

Corey: Yeah, the entire ice shelf is going slushy under their feet. The temperature is raised like one degree in . . . I can't remember the time period that it's raised one degree, but one degree is significant in the ocean and on a ice shelf. One degree can make a major difference in the rate of melt.

David: It does sound familiar to me because we have other data that supports this: one of them being all the volcanic activity in the world from 1875 to 1993 was mapped out, and there was a 500% increase in global volcanic activity during that time.

So is that what's causing this?

Corey: Yes, and according to the information I have, these energetic changes that are occurring in our Solar System are causing this heating up process on our planet and other planets as well.

David: We have this idea that we talked about before, that **Pete** Peterson said there was one mothership that he estimated, based on his intel, as being 30 miles across and having a kind of elongated oval shape.

You then said that there were three.

Corey: Yes, but . . .

David: So what's the latest data on that?

Corey: The information I got was that they wanted me to give clarity that there was one miles-long craft that was up to three miles and oval shaped, and then there were two smaller, I guess, support-type craft that would be in a fleet that survived the attack and trip down from the Moon to here.

David: So this was something they felt was important for you to clarify for everybody – that it's not 30 miles wide. It's only more like three miles wide?

Corey: Right. Yeah, they thought that a little bit of clarity on that was in order.

David: Okay. But that is still an absolutely spectacularly large object.

Corey: Absolutely. And in the largest craft, there have indeed been located a bunch of beings in stasis, and they are the original beings from, I guess, Mars, that had come here – the original pre-Adamites.

Most of the ones that we've been dealing with since this great catastrophe are some sort of hybridized type of pre-Adamite that survived.

It's obvious that the pre-Adamite group, before they had to move here, had already been taking part in these genetic experiments, according to whatever agreements that were made with these other groups. There are up to 22 different genetic programs going on.

David: Oh, so the pre-Adamites were part of the genetic farmer initiative?

Corey: Right. They were taking part, but they seemed to have a problem getting along with other groups. They were warlike. They tended to strike first and ask questions later.

David: When we're dealing with this subject of Antarctica, something comes up for me, very interesting, which is that one of my other insiders, Daniel, said that there was one natural ancient stargate on Earth.

He told me this years ago, and I put it on the Internet, . . .

Corey: I was about to lead into that.

David: . . . and that it was in Antarctica.

Corey: Yes.

David: So something that you said recently, not on our camera yet, just blew my mind, because it's a perfect one-to-one correlation. So could you talk about that?

Corey: One of the most important aspects of this Ancient Builder Race technology that they were trying to control was that there was a very powerful Supergate that is in Antarctica. And it was built by the Ancient Builder Race.

David: I'm sorry. Let me hold you right there. What is the difference between a Supergate and a stargate? Because you never said 'Supergate' before.

Corey: A Supergate has the ability to travel from one end to the other through the cosmic web, no matter how far it is – anywhere within our galaxy or to local galaxies.

David: Right. That's exactly how Daniel described it.

Corey: Right. Now, these other nodes that we have on the planet, you have to jump a few times to get to your location if it's very far.

David: So it would be like getting a transfer? You have to stop in one place, get out of a gate, to go another location, and then another one?

Corey: You have to wait for the electromagnetics to line up properly between different planets . . .

David: Oh!

Corey: . . . as they are spinning and turning within their local star system in relation to their star with those electromagnetic connections between their planet and their star, and then their star and our star have an electromagnetic connection through this cosmic web.

And those present electromagnetic, I guess, tubes for matter to go from point A to point B through.

David: Do they have the ability, when they make these stopovers, to fast forward time? Do they have time acceleration capability, or do they have to build little resorts that they would stay in in order to wait for the next gate to open and kill some time?

Corey: No, they do have to wait and kill time.

David: How long might they be waiting?

Corey: It just depends on where they're traveling and how long it's going to take this – it's like a big clock – wait for all the mechanisms to be lined up just properly.

David: Are you saying that some of these waits might be years in duration for our time?

Corey: I'm sure they plan it out much better than that. Yeah, they have all the mathematics for predicting all of these locations that they want to go to down very well.

David: So you're saying that the Supergate isn't like that. The Supergate will take you wherever you want to go, . . .

Corey: Right.

David: . . . whenever you want to go.

Corey: Right, and it's a part of a . . . very much like Stargate Atlantis or SG1. An Ancient Builder Race built a network of stargates that are very powerful and very reliable. They can be turned on and used at any time. You don't have to wait for calculations. Now, . . .

David: What about the ring shape that we see in Stargate? How does that compare with what it looks like?

Corey: It doesn't look anything like what they show.

David: Oh!

Corey: No. Usually, you have . . . You're in the middle of the room. The middle of the room is open.

David: What's 'the room', first of all? So it's an indoor structure?

Corey: Well, just gates in general.

David: Okay.

Corey: There's not some sort of orifice that you walk through.

David: Okay.

Corey: Usually, there is at least three different points that are opening, that are out in the periphery of the room, opening in a empty part of the room, a vortex that is a three-dimensional ball that looks like a mirage.

David: Okay.

Corey: And as people walk into it from all directions, it looks like they're shrinking as they . . . almost like they're walking downhill. They're going down into it.

And it's pretty much the same in this Supergate.

One of the things that I haven't mentioned is that they can, by the amount of energy they feed and the type of energy they feed in, and at what oscillations, they can use these gates for traveling in time as well.

David: So the room, then, you're saying, is like an Ancient Builder Race underground facility that you would go into?

Corey: Yes.

David: Could you paint for us a picture of how big that room is? Is it primarily just the three emitters in the room, and you walk into the center, or might that be part of a bigger facility?

Corey: I haven't actually seen it with my own eyes.

David: Oh, okay.

Corey: But most of the Ancient Builder Race technology are built in very large rooms with very large hallways and doorways, so these were not small beings.

David: So this idea of the Supergate and the Ancient Builder Race, it seems to me like it couldn't just be one Ancient Builder Race if it's outside of our own galaxy, that there might have been some ancient effort to do this on a widespread scale. Do you have any specifics on that?

Corey: Most of the information I've had is that they created this stargate system in this local star cluster of 50, 52 stars.

Now, they do branch out and go to other locations, but this race could have . . . They had plenty of time to map out the galaxy and put stargate locations where they wanted.

They could very well have collaborated with other races in ancient times.

David: Daniel's testimony, also, I just want to get this in, was that you couldn't bring metal or any type of weapons or anything that was non-organic through these original Ancient Builder gates.

I'm curious if you ever heard about that one way or the other.

Corey: No, they had some issues. They had some calibration issues that took them a while to figure out. The gates had to be calibrated, somehow. They were in time-space and in some sort of a network communicating with each other, and they figured out how to do it.

They ended up getting the gate to where they could bring anything from point A to point B. Now, the

biggest problem they had were when they were creating their own stargates with our technology. In the beginning, we could only send supplies from one place to another, and then we would take a craft there, because organics would not make it from point A to point B intact.

David: When you say 'they' were making stargates, which 'they' are we talking about now?

Corey: The precursor to all of these Secret Space Programs, back in the '50s and '60s when they were figuring out how to do portal travel . . .

David: Right.

Corey: . . . with the technology they had back-engineered from non-terrestrials.

David: One of the things that Daniel said about the Supergate was that the early, early 1970s' analysis of it led to the development of the IP address protocol for the Internet, because apparently every gate location has a numerical address similar to what we use for the Internet.

I'm curious about your thoughts on that.

Corey: Yes. I don't know if ARPANET developed TCP/IP communication protocols to mimic what was occurring in the Supergate, or if they even knew about it, but they work very much the same.

You even have subnet masks to mask certain gate systems so you don't end up going there.

Yeah, it works in a very similar way.

David: Okay, let's get back to these pre-Adamites, and you say that they were shot and burning. They crash land in this continent that was not, obviously, a glacier back then.

What was the strategic significance for them having access to the Supergate? Did they have a surviving part of their civilization that they could still visit with it, or were they trying to visit other civilizations? What was their goal?

Corey: You know, I really don't know what they were do . . . They wanted control of the gate, but not all of their species were trapped with them.

Originally, when they had escaped from the exploding planet, and then later on, when Mars became uninhabitable because of further warfare, . . .

David: Right.

Corey: . . . a large group of them went towards the outer Solar System and out and away, and then another group of them went towards the Moon and Earth.

David: Ah! So they were able to reach out to some of their lost refugees once they gained control of this gate?

Corey: That would . . . That would make sense.

David: It does make sense.

Corey: Yeah.

David: So who's in control of the Supergate right now?

Corey: This same shadow government group that has control over the spaceport and this Antarctic Area 51 area. It's the same group.

They have control over it, and they're trying to figure out what to do with a lot of this. They're finding so much.

Obviously, they're learning to back-engineer and cannibalize that technology to add to our existing space fleet technology.

David: Now, in our previous update, you mentioned Ka'Are and others bringing you to some kind of library in Antarctica.

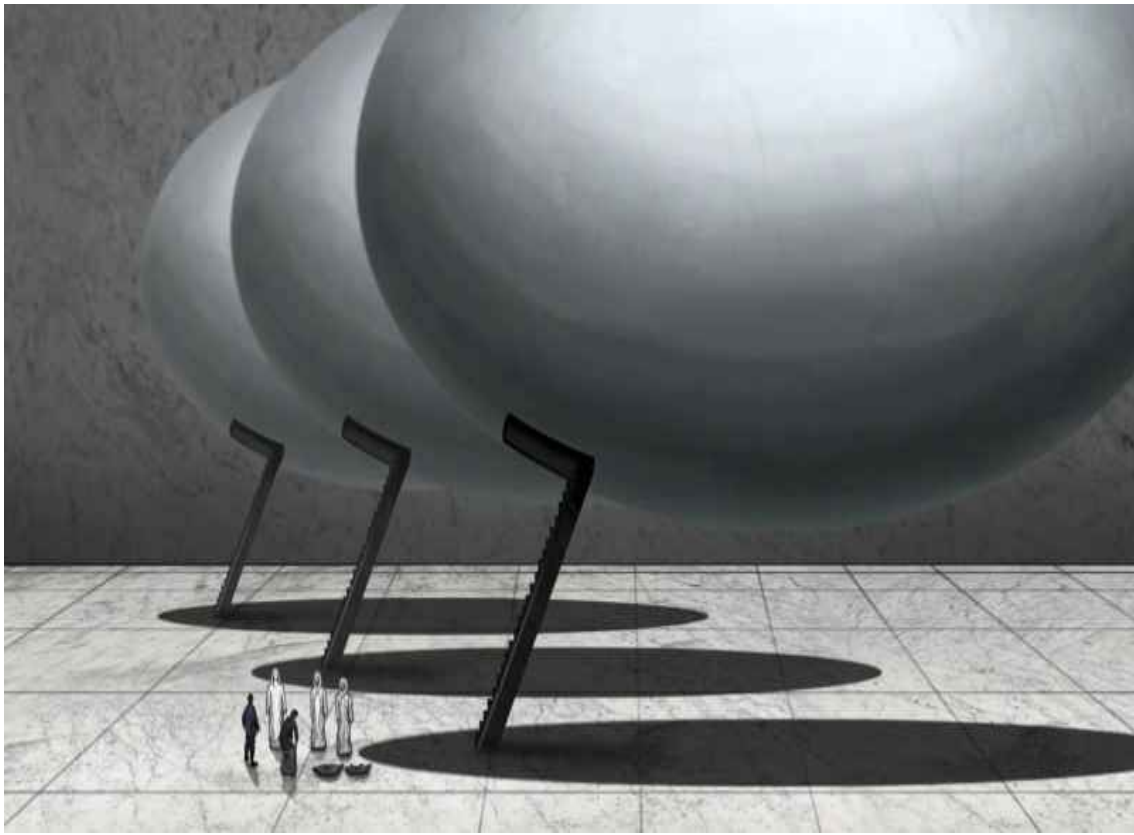

And you witnessed the extraction of scrolls from this library, but at the time, you did not know what they were or what the purpose of this was.

Do you have any further information on that now?

Corey: Well, you know according to Sigmund, what they were looking for down there were files, basically, that had, I guess, a multigenerational bloodline list that traced way, way back – back . . . It was a historical document even before their planet exploded.

Now, what's interesting is that everything in their society depends on bloodline – where you are in the hierarchy. The way they apply their laws had to do with where you were in this bloodline hierarchy.

So these are very, very important scrolls for them for a number of reasons.

They also wanted to be able to genetically tie themselves to this pre-Adamite race and then set up this pre-Adamite race as being basically gods, and they would be demi-gods.

David: 'They' meaning the Cabal?

Corey: The Cabal.

David: So this would have given them, using a legal term, this would have given them the imprimatur to claim this divine right of kings . . .

Corey: Right.

David: . . . and an extraterrestrial bloodline.

Corey: Right. And then internally, the documents were important because it's how they jockey for position and apply laws. It's a very . . . It's a cultural thing as well. It's very important.

David: So why do you think the Anshar felt it was of such strategic significance to remove this, and why, also, would they want you to have witnessed it?

Corey: I don't know why they want me to witness certain things, but sometimes they have me witness things and it just doesn't really make sense to me.

But they obviously were removing these documents to disrupt future plans by the Cabal and some of these non-terrestrial groups working with them.

David: Would you argue that they wanted you to witness this so that everyone following this story would know about it?

Corey: I think since I'm reporting the information, they wanted me to witness it firsthand.

David: Have there been further Anshar meetings since the last updates that we did on this show, and if so, what have they told you?

Corey: Yes, I have met mainly with Ka'Aree in The Construct. And I asked her if what Sigmund told me was true, and she confirmed that, yes, that's the reason that they took the documents was to disrupt operations by the Cabal group, and also prevent them from being able to do a divine right of kings kind of thing.

David: One of the most remarkable plot twists for me was that after you and I had already exchanged a great deal of information on this, I called up **Pete** Peterson, and he starts telling me almost exactly the same stuff, but one of the differences was that he said in one of these ships that had been converted into a very advanced base, that there were groups of people who survived the Atlantean catastrophe but had gotten locked in there.

And then, apparently, our people finally dug them out. And this is only something that happened, apparently, recently.

So what are your thoughts on all that?

Corey: It's a little different than the information I received. I received information that they found very small pockets of a lot of these basically genetic experiments and humans from this pre-Adamite group.

David: Living, you're saying.

Corey: Living. That had been living basically in cavernous areas under the ice that were discovered.

I had no information about people surviving inside the ship. The information I had was that – and it would match if there were people in – was that up until the last couple of decades, it was completely

ice-locked.

And when they went inside, there wouldn't be a whole lot of technology left inside this cannibalized ship to sustain anyone for any amount of time.

David: Right.

Corey: They took all of this technology out and put it into this new city that they built. So it's a little bit of a divergence.

David: So these people could take light sources that they build, remove them from the ship, go into these caverns, grow food and have water that they can melt and make available to themselves, so they basically can have a sustainable society.

Corey: Yes, and there's also less, I guess, advanced ways of getting protein and vitamins and minerals, other than using technology. There is an ecosystem underground that they could probably use as well.

David: You said that some of these people were chimeras, these animal-human hybrids?

Corey: Yes.

David: What types have survived?

Corey: I haven't heard the specifics, other than there were humans, and then some of these strange sort of experiments that were being created by the Pre-Adamites.

David: So let's talk a little bit about these stasis beings. They trace all the way back, you're saying, to this Super Earth before it blew up 500,000 years ago.

How many of these beings are there, and is there any way to wake them?

Corey: Well, I don't know the exact number. There are a number of them that are in stasis.

David: Tens, hundreds, thousands?

Corey: Nowhere near that many. I think it's maybe a handful, a dozen.

David: Okay.

Corey: And this group has put themselves in stasis at some ancient point, and they've been in this ship for a long time. And it was very important for the people that were guarding them to also get them down to Earth and hook up to the power source that the Ancient Builder Race was using to help them keep this stasis chamber and the ship working.

It is piped right into the Ancient Builder Race power source.

And they have figured a way to awaken them. They are unable to awaken one at a time. They have to awaken them all at the same time.

And there are a lot of security concerns about what's going to happen after they wake them.

I mean, everyone who has seen the movie Prometheus will see where the concerns are.

David: So you're saying that this would be a being that has literally edited out the last half million years of history, and wakes up knowing only that it went down when its planet either had been destroyed or was about to be destroyed.

Corey: Right.

David: How are they addressing the problem of these beings potentially being very dangerous when they wake up?

Corey: Well, there's pretty much a committee trying to figure out whether they're going to wake them or not. But in case they decide to wake them, they have these little mini-nukes, like these fifth-generation type nuke weapons that they have sitting right in the middle of all these beings in stasis.

And when they awaken these . . . if they awaken these beings, they're going to have the people there with, basically, dead man triggers.

If the pre-Adamites become violent or hostile, then they can be eradicated very quickly with a large nuclear explosion.

David: Well, this is really fascinating, and I thank you for continuing to be on the front lines and having these experiences to share with us. It's very, very interesting.

And again, even if you don't believe this, necessarily, it's a very fascinating story, far deeper and more complex, with threads to so many things that I've been researching over the years. I find it very believable in light of all the data that surrounds this.

I'm [David Wilcock](#). This is "[Cosmic Disclosure](#)", and I thank you for watching.

[Cosmic Disclosure: Faster Than Light Technology with Mark McCandlish](#)

Season 7, Episode 20

[David Wilcock](#): All right. Welcome back to "[Cosmic Disclosure](#)". I'm your host, [David Wilcock](#). I'm here with **Corey Goode**. So, **Corey**, welcome back to the show.

Corey Goode: Thank you.

David: We're going to start out now with the first of a series of interview footages from **Mark McCandlish**, where he's going to be talking about a particular type of propulsion system and a particular craft that one of his insider friends saw.

So without further ado, let's take a look.

* * * * *

A TOUR OF HIDDEN TECHNOLOGY

Mark McCandlish: I get a phone call from a friend of mine that I'd known in college. For the sake of this conversation, I'll call him Brad.

So Brad calls up, and he says, "You know, I saw your article. I saw your art work, saw your name in the magazine, got a hold of the art director. He gave me your number, and this is Brad. Do you remember me?"

And I said, "Yeah. That's great."



So we got together for lunch. We were talking, and I mentioned to him that there was an air show coming up at Norton Air Force Base, which is in San Bernardino. It's about 75 miles east of Los Angeles.

And there was a story that they might have the SR-71 Blackbird either do a flyby or that it might be on static display, which was kind of rare back then.

So we decide we were going to go to the air show. And at the last minute, the magazine called up and indicated that they were so happy with that illustration that they wanted me to do another illustration that was going to be coming out the following year in February of '89, on the X-31 program.

So they wanted it completed as a quick turnaround, and so I basically had to pass on going to the air show.

So about a week goes by, and I didn't hear anything from Brad. And I called him up, and I asked him, "Well, how did you like the air show?" But on the phone, he was very quiet.

And I said, "Well, what's wrong? You don't sound like you had a very good time at all."

He said, “Well, I think I saw some things I wasn't supposed to see.”

And I said, “Well, how can that be? Everything that's at the air show is put there for static display for the public.”

And he says, “Well, there was another little show that happened while we were there.”

And in the beginning of this story, when this first came to me, he made it sound as though the exhibit that he was allowed to go into, the person that he had brought along, someone that we were going to network some illustration jobs for, was a high-ranking person at Lockheed Martin, and that they were going to . . . we were going to get together and talk about doing some work.

And this individual, right about the time the Thunderbird, the Air Force demonstration team, was about to start their program, he says to my friend, “Let's go over here.”

So this gentleman, my friend, a number of high-ranking politicians and high-ranking military brass, all boarded a Boeing 727, military airliner – military aircraft with passenger seats and so forth. And they departed from Norton and flew up to Air Force Plant 42, which is in Palmdale. That's where Lockheed Skunk Works is located.

So the plane rolls out. They get out of the plane, and the security detail that was around the building with a cordon and M16s, and the whole nine yards, challenged my friend because he didn't have any kind of a badge or anything like his escort did.

And so his escort essentially vouched for him, saying that he was this gentleman's aide.

So they go into the show, and as soon as they walk in, he looks around and he says, “Okay. I can see that there's some things here that I wasn't told about, things that you're not cleared to know about. So just keep your mouth shut. Don't say anything. Don't talk to anybody. We'll get out of here as soon as we can., but enjoy the show.”

So Brad indicated to me that there were high-ranking Air Force officers that were walking around like

tour guides, and they were showing the various aircraft types that were on display, one of which was the first generation Aurora aircraft, what the Lockheed folks called the Pulser.

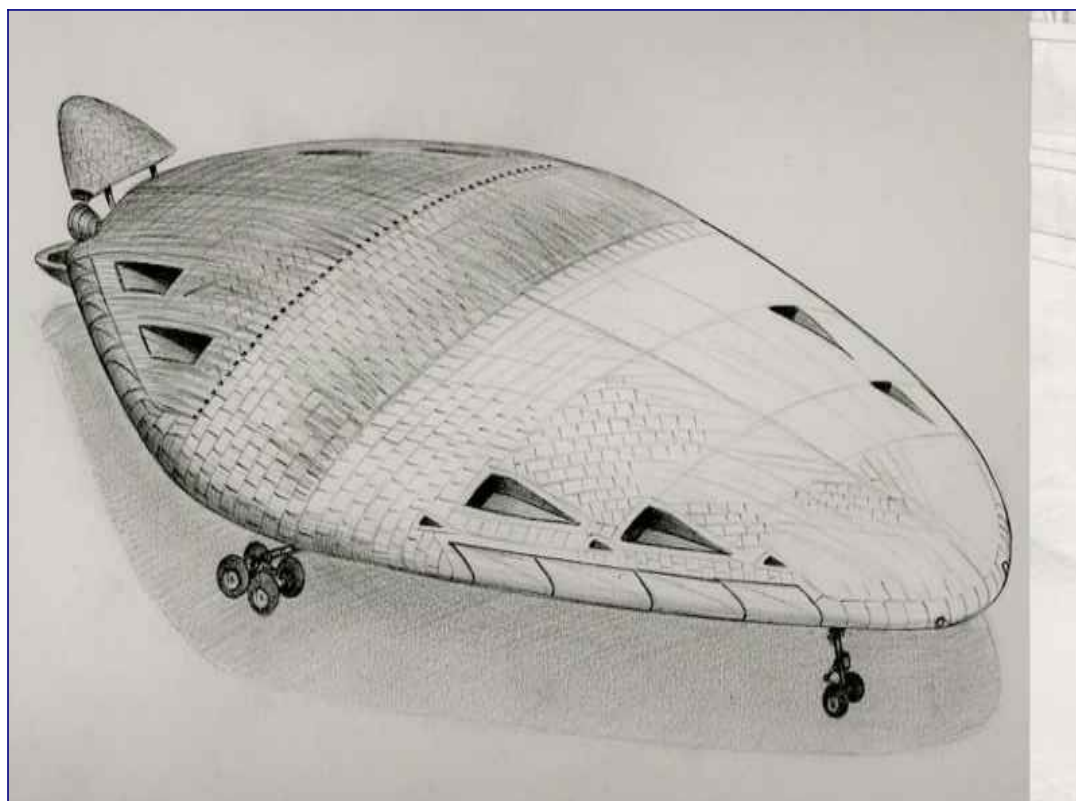
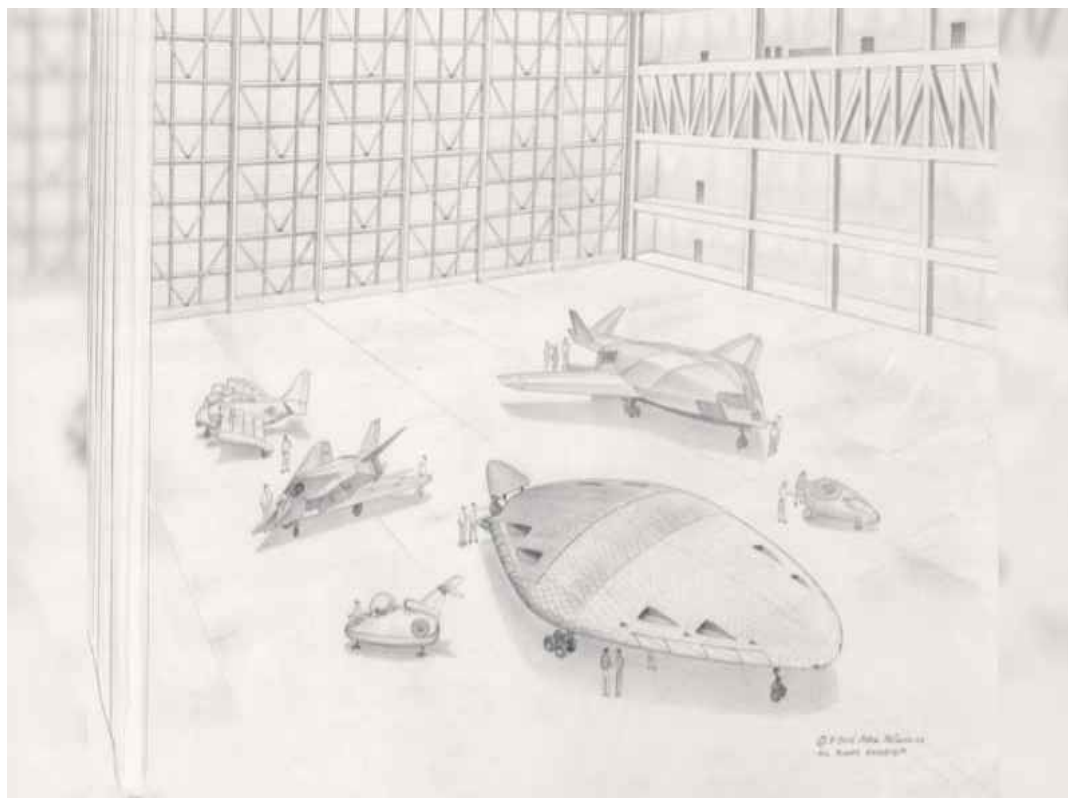

And so they had four engines that were buried in the airframe. The entire thing was covered with heat-ablative tiles, just like the Space Shuttle.

The back end of the aircraft was being used in the same way as . . . very much like the entire back end of the aircraft was like a linear aerospike engine with dozens of these fuel ejectors that would spray fuel into this supersonic shock wave and would spontaneously combust.

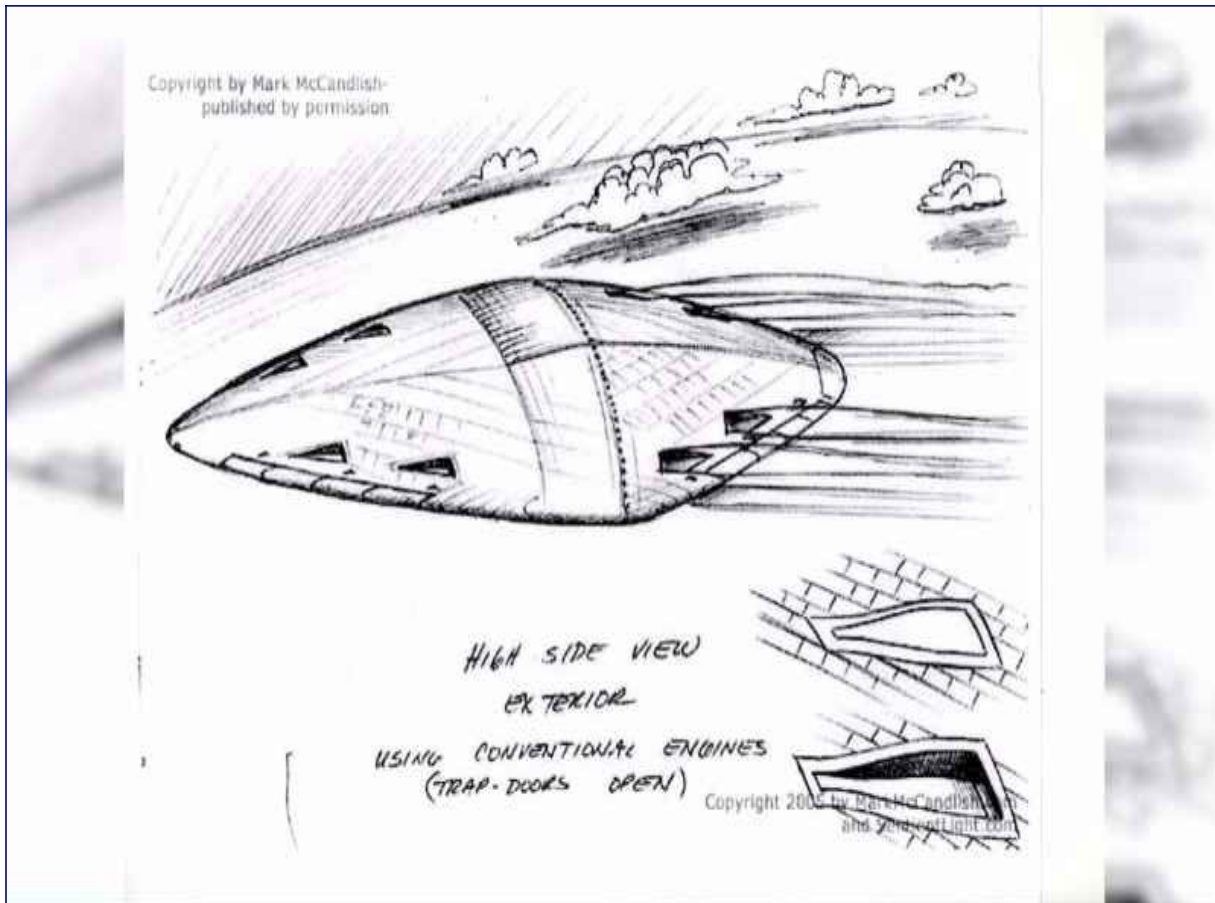

And the explosion of these gases would expand between the supersonic shock wave and the tapered afterbody of the aircraft and essentially pinch it – just like squeezing a wet pumpkin seed and having it shoot away out of your hands.

But the interesting thing about this particular aircraft type was that it obviously had some strategic applications, that it wasn't just for high-speed, high-altitude reconnaissance.

This was an aircraft that had weapons. And underneath the fuselage, buried in the fuselage between the engines, were 121 vertical launch tubes, each of which had a large circular heat-ablative tile on the

outside that could be blown away with explosive bolts.

And what was so fascinating about this design was they kept it as simple as possible, but it was totally effective.

And they had what amounted to . . . that you could use either conventional explosive-type warhead, but they were in re-entry vehicles like the MIRVs that you see on an ICBM, except that above this MIRV in the tube, they had another heat-ablative tile with a big coiled spring behind it, all compressed.

And so as soon as they blew away the outer tile, this thing would be spit out of the tube. Another tile would come down, slam into place, and immediately restore the aerodynamic efficiency of the aircraft.

So you didn't have bomb bay doors and this kind of thing opening up when you're going at high speed.

Another one of the things that I found from recent disclosures was that when the aircraft was actually in the active functioning as a weapons platform, that it had a tertiary, a third type, of propulsion system where the back end, which was kind of flat but triangular shaped, it would open up.

It was like a clam shell on the back end, and a rocket motor would pop out, and this thing could then climb up into an exo-atmospheric launch position and loiter almost indefinitely.

This was probably one of the largest remotely-operated vehicles that's ever been in the inventory. But it did have a provision for being piloted by someone internally. But mostly, it was an unmanned aircraft.

But it could go up, and it could deploy these MIRV-type weapons from space.

* * * * *

David: Well, for me, **Corey**, as an outsider who has not been in these circuits, when somebody comes forward and has this much technical detail, I'm extremely, extremely fascinated.

I've heard about the Aurora for so many years. Never have I heard the kind of detail that he just gave here.

What are your own thoughts in light of what we just saw?

Corey: Yeah, it's the amount of detail. That's what I was going to comment on.

The people that come out and talk about these things have normally just had a glimpse of them. They haven't had someone that was able to walk around and kick the tires and have a tour from Air Force personnel.

So this is very good insight on the way this craft works.

David: I had heard about the Aurora making this very loud jackhammer type of noise as it traveled.

Corey: They left what they called, what, "donut contrails"?

David: Right. But never have I gotten anywhere near that type of technical detail about it.

What do you feel this kind of a craft, the Aurora, which apparently is one of the more classic designs, even all the way back to the '80s and so forth . . . What might the Aurora be used for?

Corey: Back in that day, all high-altitude craft were usually exclusively either for a reconnaissance or for delivering . . . as weapons platforms.

And a lot of times, they can have technology switched out on them, and they can be either/or.

David: Are you saying, then, that the Aurora might have been used in conventional warfare, just that the people who get hit by those bombs don't know where they came from?

Corey: It's possible that it was used in conventional warfare, but it sounds like that was saved for . . . it was in the inventory for a special event, like if there was a conflict with the Soviet Union.

David: All right. We're now going to get into actual blueprint illustrations that he gave from insider testimony of the Alien Reproduction Vehicle, or ARV, which seems to be an exact duplicate of the original German Bell Craft. Let's take a look.

* * * * *

ALIEN REPRODUCTION VEHICLE

Mark McCandlish: There was also a separate display that was presented after all of the people, the attendees of this exhibit, showed up.

They brought back the curtains, and there were here the three flying saucers, what eventually became known as the Alien Reproduction Vehicle or Fluxliner – ARV for short.

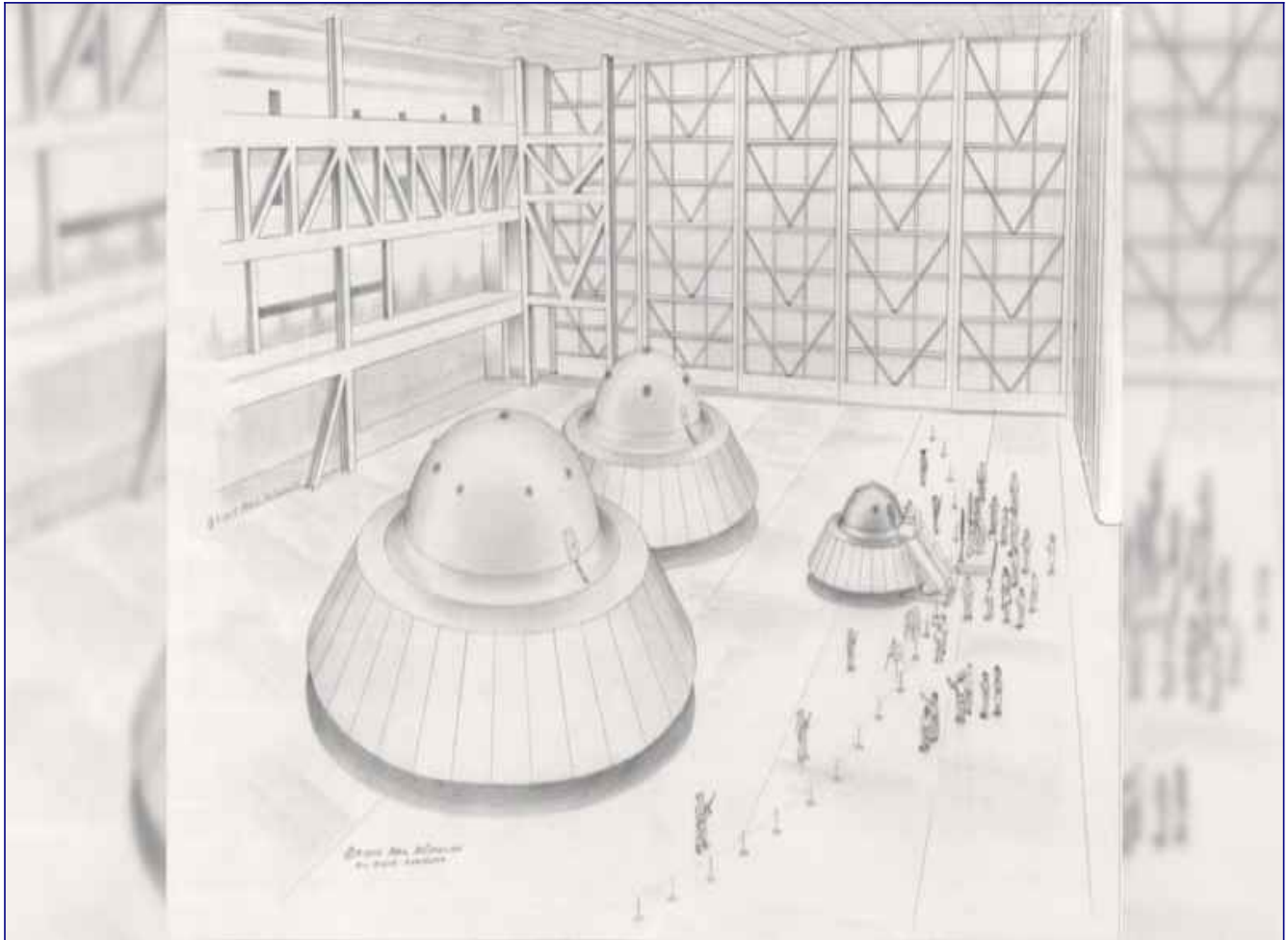

And that's when I began to understand that there were some really wild and advanced systems that were under development.

Not only were they on display, but these craft were hovering off the floor. There were no landing gear underneath, no cable suspending them from the ceiling.

The smallest one was approximately 24 feet in diameter. The next one up was 60 feet in diameter, and the largest of the three was approximately 120 feet in diameter.

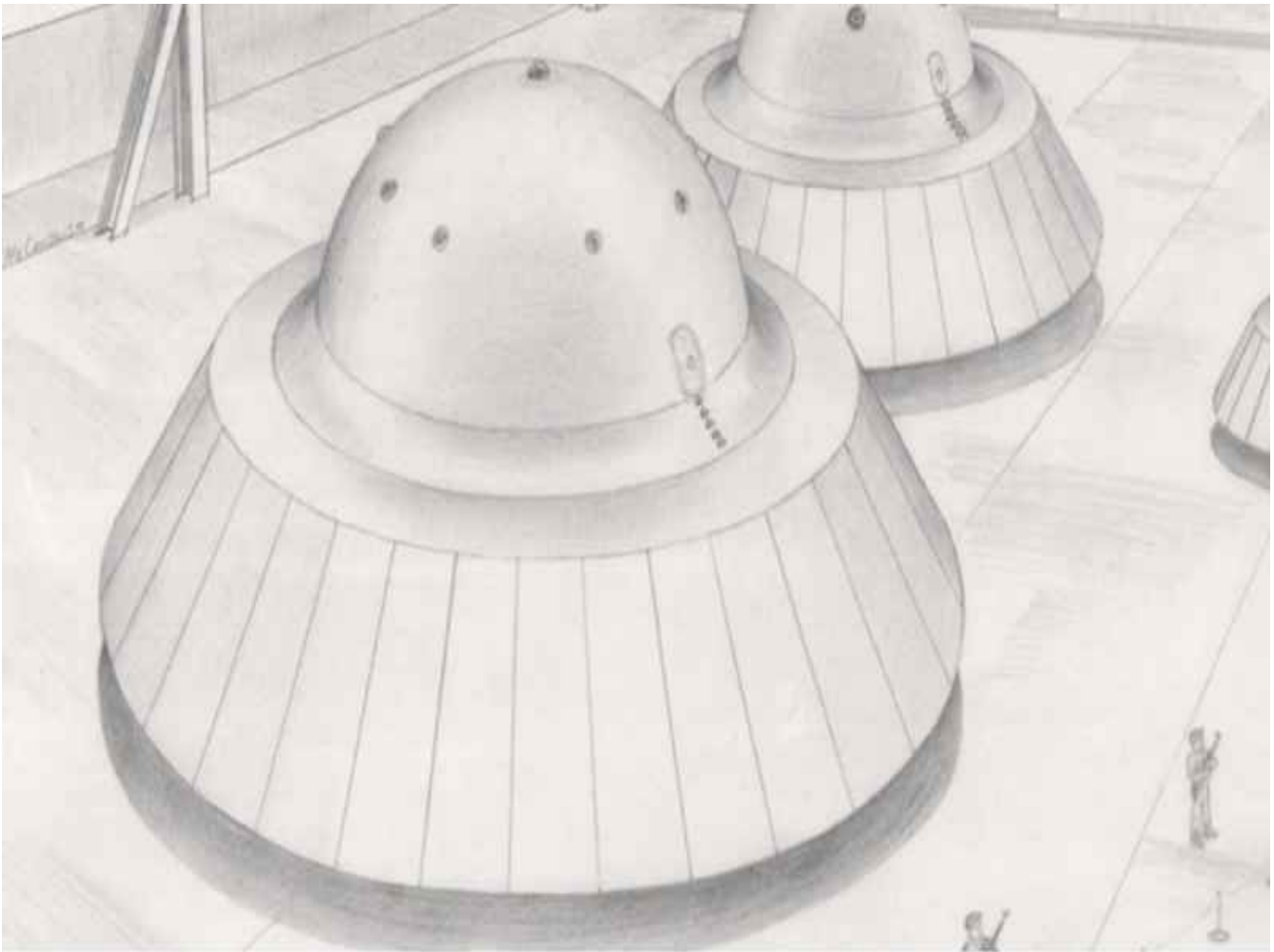

The interesting thing about that particular part of the exhibit was that Brad commented that these aircraft looked like they'd been around for a very long time. And this was in 1988 – November 12, 1988.

And he said that there were a number of panels around the perimeter of the fuselage, flat on the bottom, sloping sides at about a 35° - a little bit of a ledge around what appeared to be a crew compartment, and then a dome.

And on the top of the dome were these little clear blisters with a little . . . like a CCD-type camera in each one on a little gimbal that would move it around and point it and this kind of thing.

And this, again, was another use of something like a synthetic vision system, where two of the cameras could be slewed together in pairs to create a left eye and right eye view so that the pilot wearing a special helmet inside could have a completely three-dimensional view.

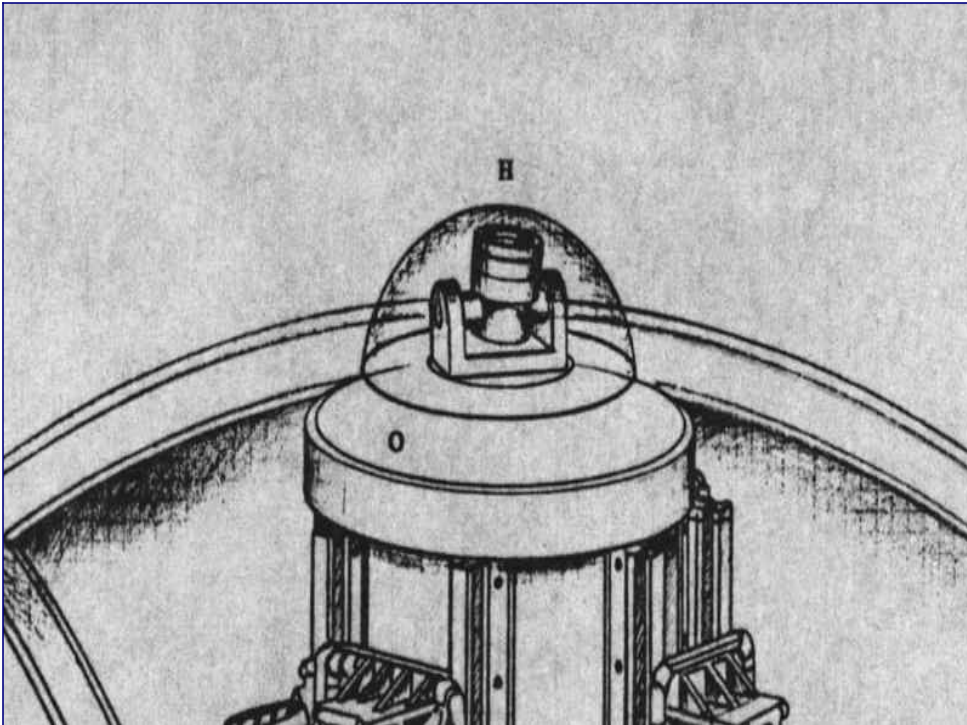

And what eventually became obvious was that the system was using an unusual technology to create electrical power, drawing it right out of the vacuum of space-time called scalar energy or zero-point energy.

But when this thing was powered up, it would create such a tremendous amount of ionization around the craft that the air molecules would actually begin producing X-ray photons, which are lethal.

And so you couldn't have windows in this thing. You actually had to have some kind of a synthetic vision system to be able to pilot this thing.

But getting back to his description of the craft, he was saying that the entire thing looked like it was covered with what looked like a resin-based paint that had little flecks of metal embedded in the resin that had been just slapped onto the sides of the aircraft.

There were chips and cracks and things around the Dzus fasteners that held these panels around the perimeter of the fuselage, you know, greasy handprints and this kind of thing.

And so he said it looked like it had been around for a very long time.

* * * * *

David: There's a lot of specifics in terms of what he's saying here, one of which was that ionization is forming around the craft when it's powered because of how much electrical charge it has, and that it actually releases X-ray photons, which are so deadly that there can't be windows in the craft.

Now, I was under the impression from some of the illustrations you commissioned before of the Maria Oršić and the craft that she came out of that they did have porthole windows in the craft.

So do you think maybe there was an innovation that allowed those windows to block X-rays, perhaps?

Corey: Yeah. A lot of the craft do have windows in them, especially back during the time that the Nazis were developing it.

And they didn't have the cameras, I don't believe, set up. They may have. I can't remember. There were . . . actually, some of the images, there were what he called blisters, the clear, see-through hemispheres that pop out that cameras go inside of.

I've seen some of those on some of the craft, but I don't recall that they were using cameras for visual reference.

David: Just so that we're absolutely clear, how close is this description that he's giving to your understanding of the original German Die Glocke-based craft?

Corey: From what I understood, the ARVs were hand-me-downs from the Germans, and they were calling them ARVs, or Alien Reproduction Vehicles, as a way to throw people off of where they came from.

David: Where did they come from?

Corey: The Germans, during the exchange after 1952, when the breakaway Germans started working closer with our military-industrial complex.

David: Why would the craft be able to ambiently float if it's not actually running? Or is it in some sort of hovering state to keep it hovering like that?

Corey: They use anti-gravitic propulsion, so it can be put in, basically, a neutral state and locked into one place.

David: All right. There's a lot to talk about here, so let's keep the party going. We're going to have more from **Mark McCandlish** on this amazing observation and the illustrations that resulted. Let's take a look.

* * * * *

INSIDE THE ARV

Mark McCandlish: As a draftsman, someone with my experience in conceptual art, one of the ways that I was able to figure out how all these components related together – a number of the panels had been taken off of the vehicle – the smallest one.

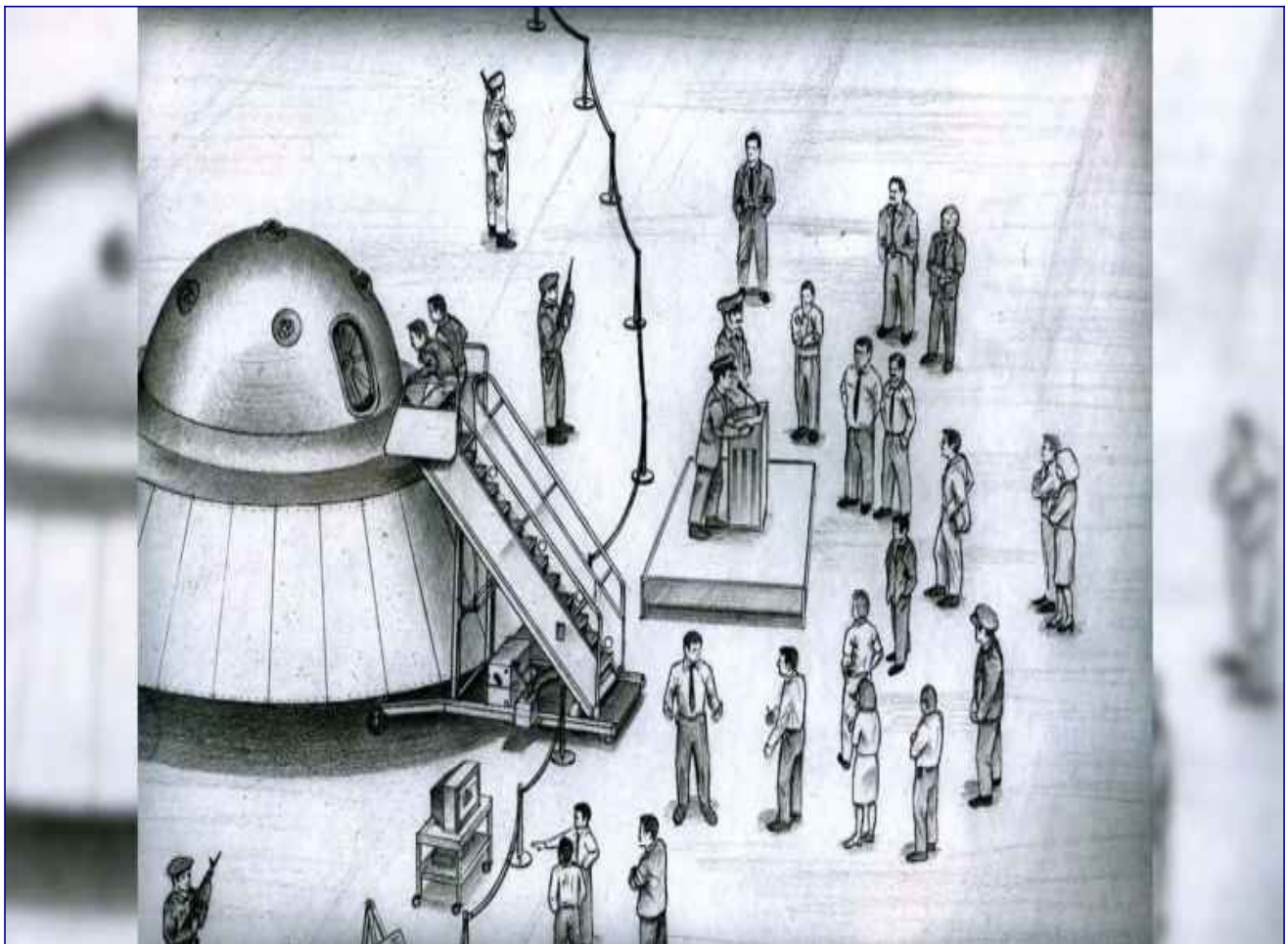

They had a rolling staircase that came up next to it with kind of a platform that rolled underneath the vehicle, and then the stairs that went up on the sloping side. And you could actually stand on a little platform and look through the cockpit door.

And what's so funny is that the door itself looked like something off of an old Captain Nemo submarine with the steel frame and the wheel you would turn and little pins that would go on the frame to lock it into position and everything.

But he said you could look inside, and you could see the ejection seats.

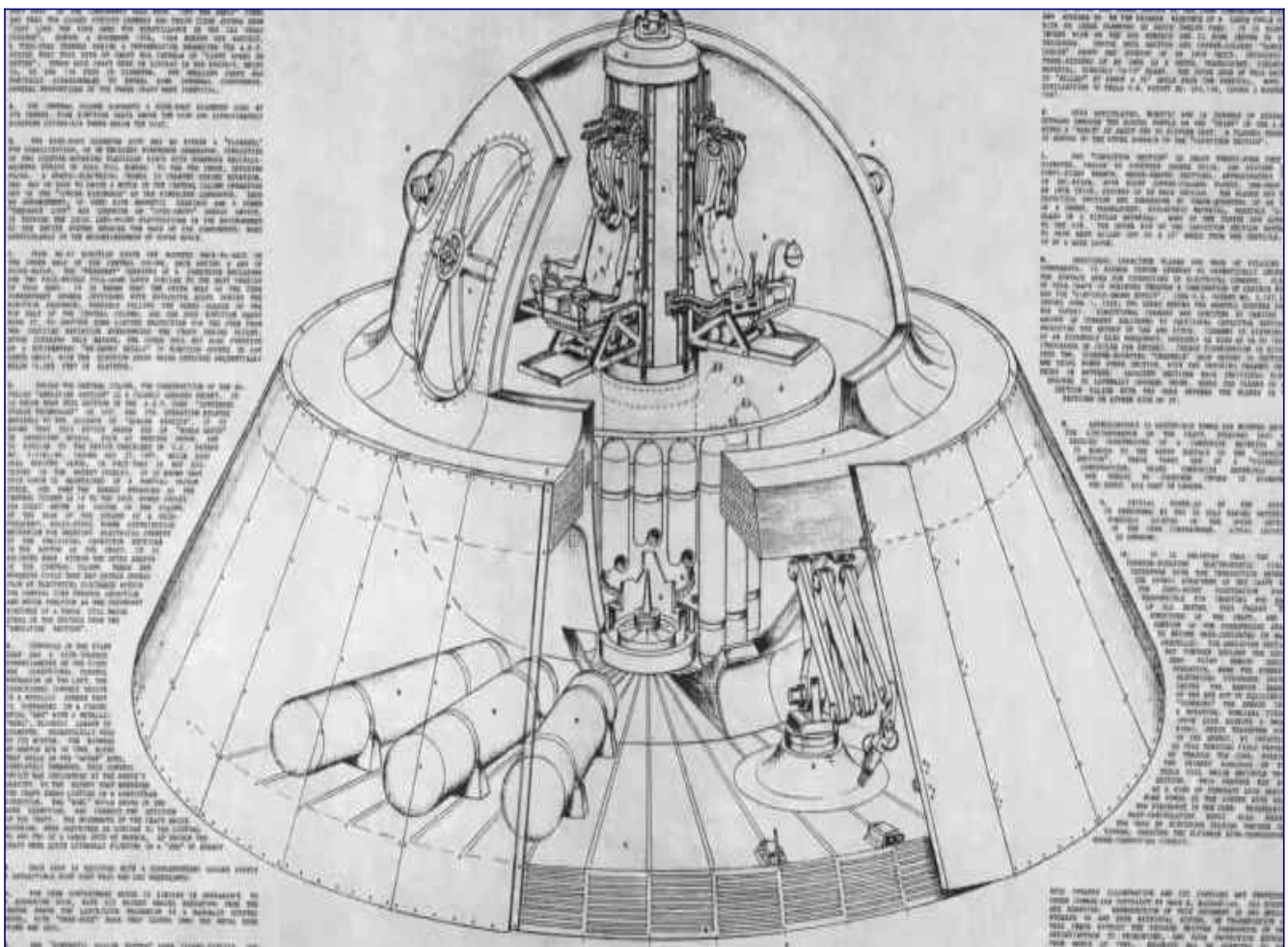

The central column that runs down through the middle of this crew compartment, which is really just a large composite sphere. It's what they call a pultruded vessel.

Pultrusion is a process where you take a filament like fiberglass or carbon or Kevlar, and you

impregnate it with a resin as it's being spun around an armature, a shape, a vessel.

They make oxygen tanks out of this kind of thing now, but this entire sphere was one large pultruded sphere. And the whole thing . . . The idea is that while this resin-impregnated fiber is being wrapped around this shape, it's under high tension, so the entire structure is pre-stressed before the resin kicks off, is catalyzed, and hardens and becomes very strong – stronger than steel.

And so these things could actually go into the ocean, too, which is another whole story.

But the view of the cockpit revealed that it was really spartan inside, I mean, no instrument panel, no gauges, no kind of telemetry. Everything was in the headset that the pilot wore.

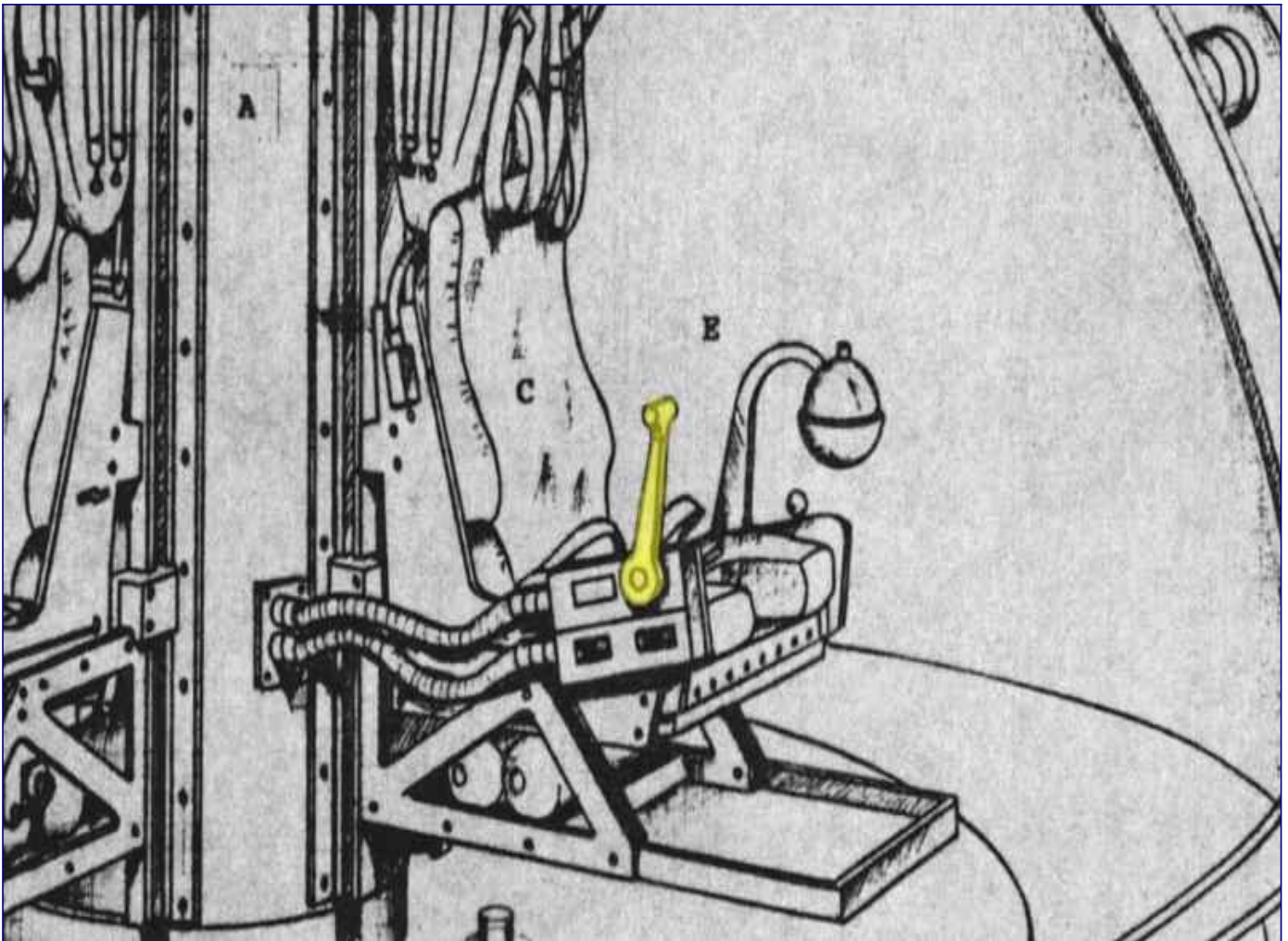

On the right side of the ejection seat for the pilot was like a big potentiometer, like something from the “Frankenstein” movie, where you control the amount of electricity.

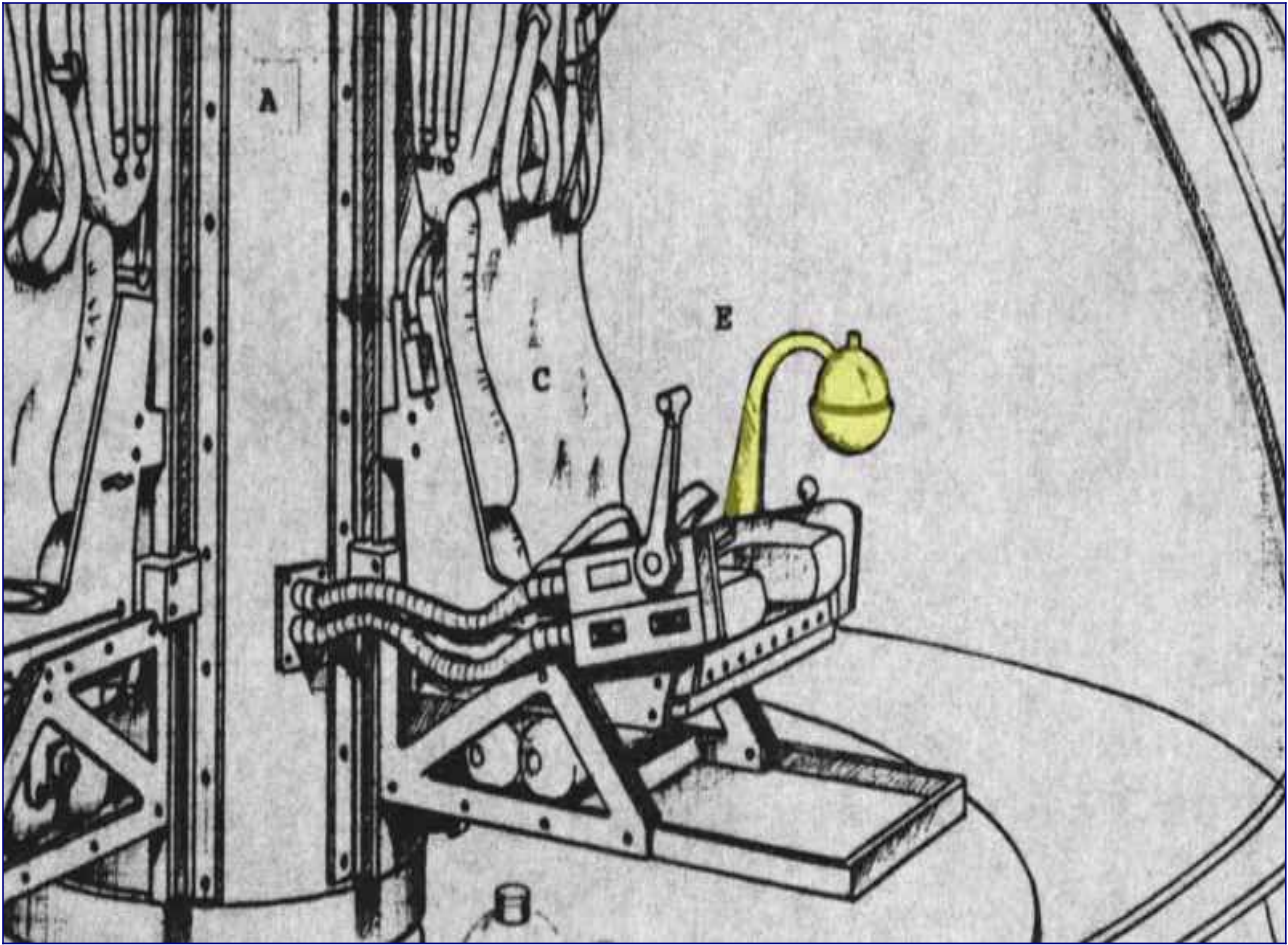

And on the left side was a really unusual type of control. It was a stand. It looked like a metal or a composite – sort of like an inverted J-shaped post that supported what looked like a ball that had a conformal hemisphere on the bottom side of it.

And this thing had a laser inside that would be reflected around. And it would send impulses to the different parts of the aircraft that controlled the yaw and the pitch and this kind of thing.

What was interesting was that when this thing was operating at low power and just hovering by itself, that as the vehicle would begin . . . I mean, because they looked like they were setting on the ocean, just moving around like over the currents in the water, and when it would begin to tilt a little bit to one side, the bowl that was hanging down on the underside of the sphere would begin to tilt in that direction.

The gravity had just enough influence on it that it would begin to lean it, and it would correct itself. It was self-correcting, no matter what direction it began to lean in.

The thing was able to accomplish things like traveling faster than the speed of light – superluminal speeds. “Light speed or better” was the quote from the general who was giving the presentation.

And so the question becomes how is that even possible? A lot of people think that it's just hogwash, that it's not possible.

And you have to go back, and you have to look at Einstein, his original equations, and all the things that he said about the utter impossibility of ever exceeding the speed of light.

And what he said was, in his equations and in his writings, was that as an object is accelerating through space-time, that its mass begins to increase.

But the key to that whole thing, the thing that nobody talks about, is the reason that the mass of a vehicle increases is because the interaction that the atomic structure of that vehicle has with the zero-point energy in the environment, it basically causes the atoms to become more energized.

Because back in high school physics, the big question I had was, well, if matter can't be created, can't be destroyed, the electrons never slow down, they don't follow the second law of thermodynamics, which is entropy, you'd expect them to slow down over time, but they don't.

And the reason they don't is because they're constantly absorbing this zero-point energy. And that's what keeps all the parts of the atom going all the time. That's why it never disintegrates, falls apart.

And so as an object, you know, made of atoms, goes through space-time and is accelerating faster or faster, it's absorbing more and more of this energy, and all the parts are spinning faster and faster like a gyroscope that gets spinning faster and faster.

And just like a gyroscope, if you've ever held one – like a spinning top or something – once they get going really fast, it's hard to move them around. It's the same. It's kind of like it's developing its own kind of gravity, in a way.

And so this is what Einstein said would slow things down and make it impossible to ever have enough energy to go up to and exceed the speed of light, because you're mass literally begins to approach

infinity as you get closer and closer to the speed of light.

And so what the engineers figured out was that if you used that same energy in the environment that would increase your mass, but you used it as a propulsive energy source to power your system, it means that the faster you go, the more energy you have to propel your craft even faster. You don't have to carry a fuel supply, so you don't have to worry about the weight of the vehicle.

So the faster you go, the faster you're able to go. And that's how you actually break the light-speed barrier, because your mass never really becomes anything greater than what you started out with. But you have this tremendous, almost limitless, amount of energy that you can draw from as a propulsive force.

This is probably why all the electrical components in the craft are embedded in quartz as a kind of insulator, because we're talking about millions and millions of volts of electricity.

That's also why when it's in the atmosphere, the ionization is so severe that it produces X-ray photons, and they have to have a synthetic vision system just to see where they're going.

* * * * *

David: Well, all I can say is, wow! One of the things that I believe you told me seems to have been heavily validated here, so I want to get your thoughts.

And that is the idea that some of the UFO propulsion systems work in a manner similar to – I think you were the one that said this – like squeezing a pumpkin seed out from between your fingers.

Corey: He said that, but I've said that in the past, too.

David: Right. I heard it from you before he said it.

Corey: I probably said a watermelon seed. Ha, ha.

David: Watermelon seed, right.

Corey: I'm from the South.

David: Since what **Mark McCandlish** is talking about here does appear to be at least partially speculative based on his own trying to understand what is going on and what he was told, your personal briefings – like maybe from smart glass pads – on propulsion systems, how do they compare with what he was saying here?

Corey: It's very close. I think I've described it in much the same way, including I've described how the torsion field drives worked in the research vessel, that it created an area to where there was torsion greater on one end than the other. And it was like squeezing a bar of wet soap on one end. It would just shoot out. It'd shoot the other way. So the descriptions are very close.

David: Laser, Light Amplification by Stimulated Emission of Radiation, is supposedly a post World War II invention. It's often been associated with, in the insider world, that it was discovered from Roswell wreckage, is one of the back-engineered technologies that originally formed.

Whereas here, we're portraying this as very likely one of the original German craft and therefore dating back to probably the late 1930s.

Yet, he's saying that a laser-based cupola that you put your hand on was essential to the whole navigation system of the craft.

Do you think that the Draco had given the Nazis the ability to make lasers before they were officially unveiled as a technology?

Corey: Well, you also have to remember that the Germans had a Roswell of their own. They had a craft that had crashed long before Roswell, in the '30s. I think it was – what is it, the Black Forest or the dark ...

David: Yeah.

Corey: . . . something like that? And so they had much brighter engineers in Germany than we did at the time. And they had the technology at least a decade before we got a hold of it. So they were probably able to reverse engineer what they recovered.

David: When I first saw this diagram from **McCandlish**, one of the things that really seemed mysterious to me was why did it look so hokey? Why would you have this old-fashioned submarine

mechanical-looking door?

Now that you've brought in the idea that this came from German technology, it seems to make more sense. Do you think that with the Germans' background in submarine building, that that's why there's such a similarity in how it looks, in some ways?

Corey: Absolutely. Yeah, that's exactly what I was going to say. And that Captain Nemo door probably came off of a German sub.

David: So **McCandlish** is also describing a technical means in which the craft can accelerate to lightspeed. How did you feel about his re-interpretation of the mass increase phenomenon, that instead of mass increase making it impossible to travel at light speed, that it's actually your best friend?

Corey: That's exactly what I had read in the smart glass pad, and also that that's why The-Powers-That-Be have kept the electroplasmic universe model of physics out of the mainstream, because that is the basis of the science that they used to build these craft to make them work.

David: All right. Well, we have one last piece of footage for you to see. And this is going to round off our discussion for this episode of reverse engineering and all these interesting subjects. Let's take a look.

* * * * *

TRANSVERSING SPACE TIME

Mark McCandlish: Well, in the beginning, when I saw this massive capacitor array in the bottom of the craft, that was my assumption that it was relying entirely on the Biefeld-Brown effect.

Now, what is the Biefeld-Brown effect?

Back in the 1930s or '40s, there was a student at a college – I think it was in Ohio somewhere – Thomas Townsend Brown, and he had a professor, Alfred Biefeld.

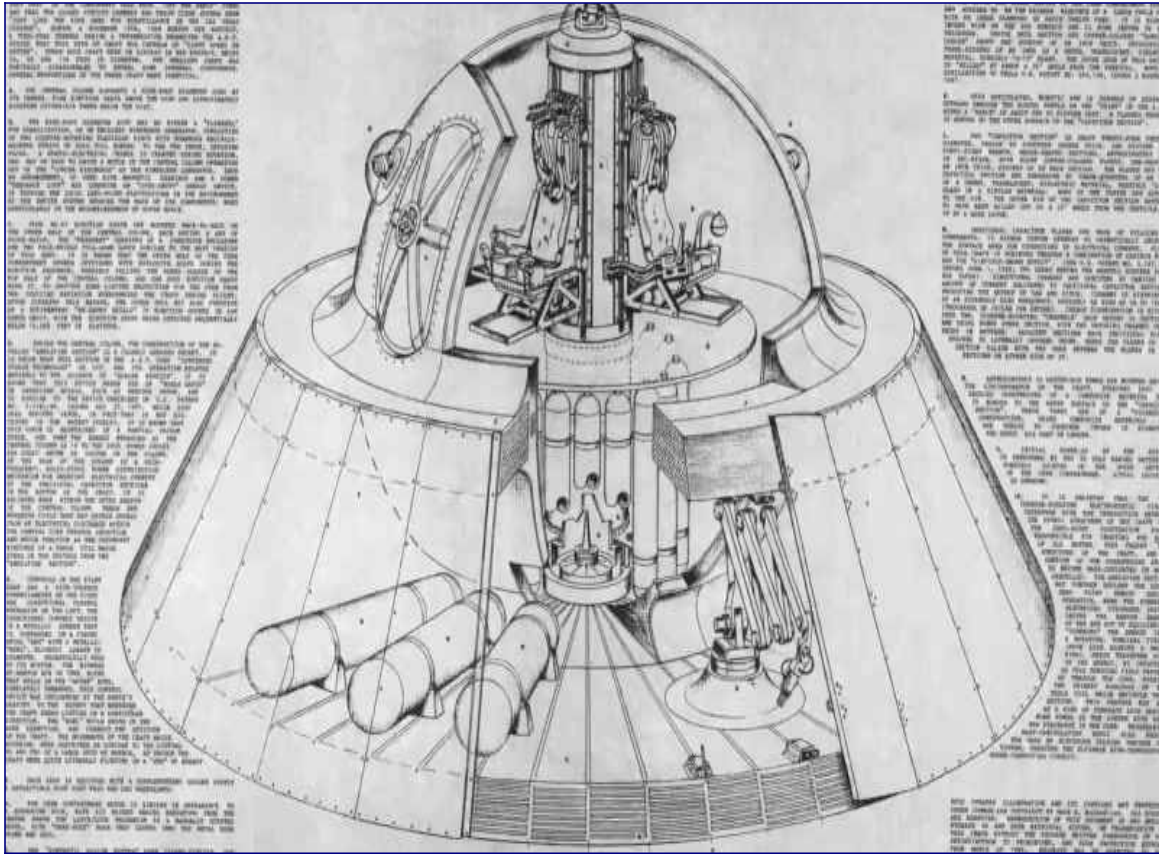

• Thomas Townsend Brown



• Paul Alfred Biefeld





And he had decided to experiment with plate capacitors, parallel plate capacitors, that were charged with electricity, and he had some kind of an insulator between them. He found that when he put the right frequency of electricity, the right voltages – usually direct current – that this thing would actually float. It would begin to levitate.

And so there's a lot of controversy about this because you see these videos on YouTube and stuff, people making lifters, and people have gotten these little bell-jar type of appliances that you find in some laboratories to create sort of a semi-hard vacuum where you evacuate all the air out of the chamber. And these things short out, and they don't work. And so they can never possibly work in space.

But if you really look at the way the Alien Reproduction Vehicle is designed, all of those capacitor plates are not open air. They are heavily, heavily insulated. And that's where the difference is.

That's why it is able to operate in outer space, is because those components don't have the opportunity to short out.

In fact, one of the things that was noticed about this quartz that surrounds these plates was that it was optically clear. It was like clear optical glass – no occlusions, no little particles of dirt, no air bubbles, no nothing.



It seemed logical to me, in the beginning, when I saw all of these parallel plate capacitors that were segmented and divided up into 48 radially-oriented sections, like long, thin wedges of pizza pie from a large pizza.

There were eight plates stacked up in each one of these wedges, which would mean, if you're talking Biefeld-Brown effect, you're talking an alternating positive, negative, positive, negative, with the positive plate being on the top of the stack, and the last negative plate being on the bottom.



It occurred to me that that was the basis for the propulsion system, but there were all these people saying, “No, no. Beifeld-Brown effect's not that powerful. You can't do that much.”

But everyone who was talking about that never talked about a system that was actually embedded in a dielectric or an insulating material like quartz.

Now, one of the things that the witness also said was that they were not just using the pure quartz. They were actually doping the quartz with heavy elements, like uranium and other things, and that they had found in their experiments over the years that when you dope the quartz with heavy elements and the starting mass of the vehicle is high to begin with, that it improves the thrust efficiency of the system when it's working.

But as time went on, I began to realize that because the thing was using zero-point energy as a power source, which is something that happens within the central column of the vehicle, this thing was creating such a tremendous stored potential of energy on the entire array of capacitors as a whole, that

it was actually beginning to warp space-time.

Now, it turns out that around 1994 – March, I believe it was – there was a scientist, Miguel Alcubierre, who wrote a paper on a warp drive, a space-type – a metric engineering space drive.



General Relativity and Quantum Cosmology

The warp drive: hyper-fast travel within general relativity

Miguel Alcubierre

(Submitted on 5 Sep 2000)

It is shown how, within the framework of general relativity and without the introduction of wormholes, it is possible to distort spacetime in a way that allows a spaceship to travel with an arbitrarily large speed. By a purely local expansion of spacetime behind the spaceship and an opposite contraction in front of it, motion faster than the speed of light as seen from outside the disturbed region is possible. The resulting distortion is reminiscent of the "warp drive" of science fiction, just as it happens with wormholes, exotic matter will be needed in order to generate a distortion of spacetime as discussed here.

Comments: 10 pages, 1 figure. Not previously available in gr-qc
Subjects: **General Relativity and Quantum Cosmology (gr-qc)**
Journal reference: *Class.Quant.Grav.*11:L73-L77,1994
DOI: [10.1088/0264-9381/11/5/001](https://doi.org/10.1088/0264-9381/11/5/001)
Cite as: [arXiv:gr-qc/0009013](https://arxiv.org/abs/gr-qc/0009013)
(or [arXiv:ar-qc/0009013v1](https://arxiv.org/abs/ar-qc/0009013v1) for this version)

And he was talking about doing this very thing, that by controlling electromagnetic and electrostatic fields, that you could create a compression of space-time ahead of the vehicle, like what you'd find with a black hole, like a singularity.

And then behind the vehicle, you would create an expansion of space-time.

And this is all kind of a polarization process, is how Puthoff described it. And he's written about this extensively.

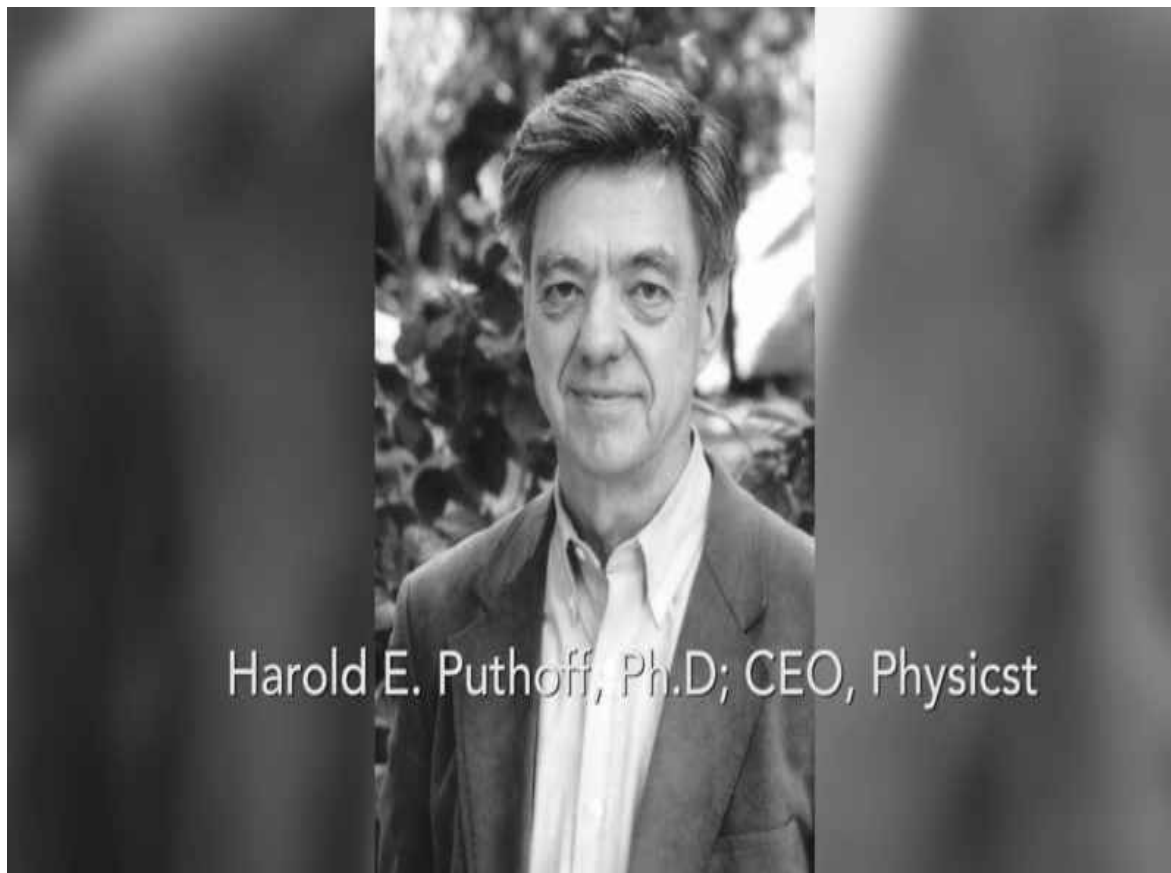

And this polarization process allows you to create what amounts to a system that is kind of like surfing on a wave, where you have a depression in front of you and a ridge behind you, and you're basically sliding down the face of this warp in space-time.

And that's what creates the vector that allows you to move forward.

But the interesting . . . The fascinating aspect to this whole concept, this principle of creating what is

called a dynamically engineered local space-time or metric engineering, is that you're taking a bubble of space-time that surrounds the vehicle, that is being created and influenced by the system inside the vehicle itself, but when this thing begins to move through space-time, it moves uniformly, where a portion of the space-time – the vehicle, the crew, the components, everything that's in it – moves as a unit.

And it's moving as a unit that's being influenced by other things that the craft is doing to the space-time around it. So it's creating an expansion of space-time behind it, a compression of space-time ahead of it. But the whole thing is moving uniformly, so there's no sense of g-forces at all. None.

So when people talk about seeing an object moving through the sky at 9,000 mph (miles per hour), plotted time-to-distance over the land, and making right-angle turns at these tremendous velocities, people who've never seen this say, “Well, that's impossible. The pilot would be turned to hamburger, smacked around on the inside of the vehicle.”

But if you're eliminating mass, then there's no inertia. And if you're talking about uniform acceleration of a metrically engineered space-time – the vehicle, its contents, and everything – the whole thing moves together so that there's no sense of g-forces at all, because there's no inertia inside this metrically engineered local space-time.

It'd be like taking a goldfish in a spherical-shaped goldfish bowl, and you move the whole thing very quickly. And the water, the fish and everything move together with the goldfish bowl, but the fish doesn't feel anything, It doesn't feel any g-forces at all.

He may notice the water sloshing around a little bit in time. But if you fill it up completely so there's no air bubbles that allow the water to move around, the whole thing moves in unison.

And that's what uniform acceleration's really all about.

* * * * *

David: Well, that's certainly pretty interesting body of data here. Have you heard, first of all, about electrocharged components being covered in a clear quartz? Have you ever seen anything like that?

Corey: Yes. A lot of times, they will have, like, a man-made quartz that's poured like glass that they can impregnate with different other types of materials. So that is something I have heard before, and it would make a great insulator.

David: Now, I noticed that he leaned pretty heavily on some physics stuff that I was well aware of in the 1990s, which is the Miguel Alcubierre propulsion method that was advanced by Hal Puthoff.

But Puthoff and Alcubierre were the ones that talked about this idea of space-time itself moving with the craft.

And since that was the bulk of what we heard here, how does that correspond with any propulsion methods that you were made aware of ?

Corey: He's exactly right. It creates a local space-time bubble that is isolated from inertia or any other forces outside of that bubble.

So being able to change directions going Mach 12 and do a 90-degree turn, there's absolutely no effect on the inside of that bubble.

David: It definitely appears that Hal Puthoff is an insider and was tasked with releasing things. I'm curious if somebody like Alcubierre . . . Did he just come up with this on his own? Or are scientists like him sometimes used to allegedly theorize about something that they already know is true?

Corey: A lot of these guys are trying to come up with these concepts on their own, outside of the programs.

David: Right.

Corey: So there are still a lot of brilliant minds out there that are thinking outside of the box. They try to keep people inside the box, the physics-model box, and working within that box. But there's always the innovative types that step outside and come up with theories that they aren't really supposed to in mainstream.

David: All right. So as you've seen here, we have some very fascinating stuff from **Mark McCandlish**, really getting into much more technical detail than you might have ever thought we could have about the original German technology that started the Secret Space Program way back in the late 1930s.

This is “[Cosmic Disclosure](#)”. I'm your host, [David Wilcock](#), here with **Corey Goode** and our special guest, **Mark McCandlish**. Thanks for watching.

[Cosmic Disclosure: Boyd Bushman's Deathbed Testimonial](#)

Season 7, Episode 21

David Wilcock: All right. Welcome to “[Cosmic Disclosure](#)”. I'm your host, [David Wilcock](#). I'm here with **Corey Goode**, our insider's insider. And in this episode, we have some rare footage from a now deceased insider from Lockheed Martin, none other than Boyd Bushman.

So, **Corey**, welcome to the show.

Corey Goode: Thank you.

David: All right. So here's our first excerpt of an interview that we did not shoot with Boyd Bushman, but is public domain, fair use on the Internet. And given the importance and what we talk about on this show, it's well worth watching. Let's check it out.





Edward Teller

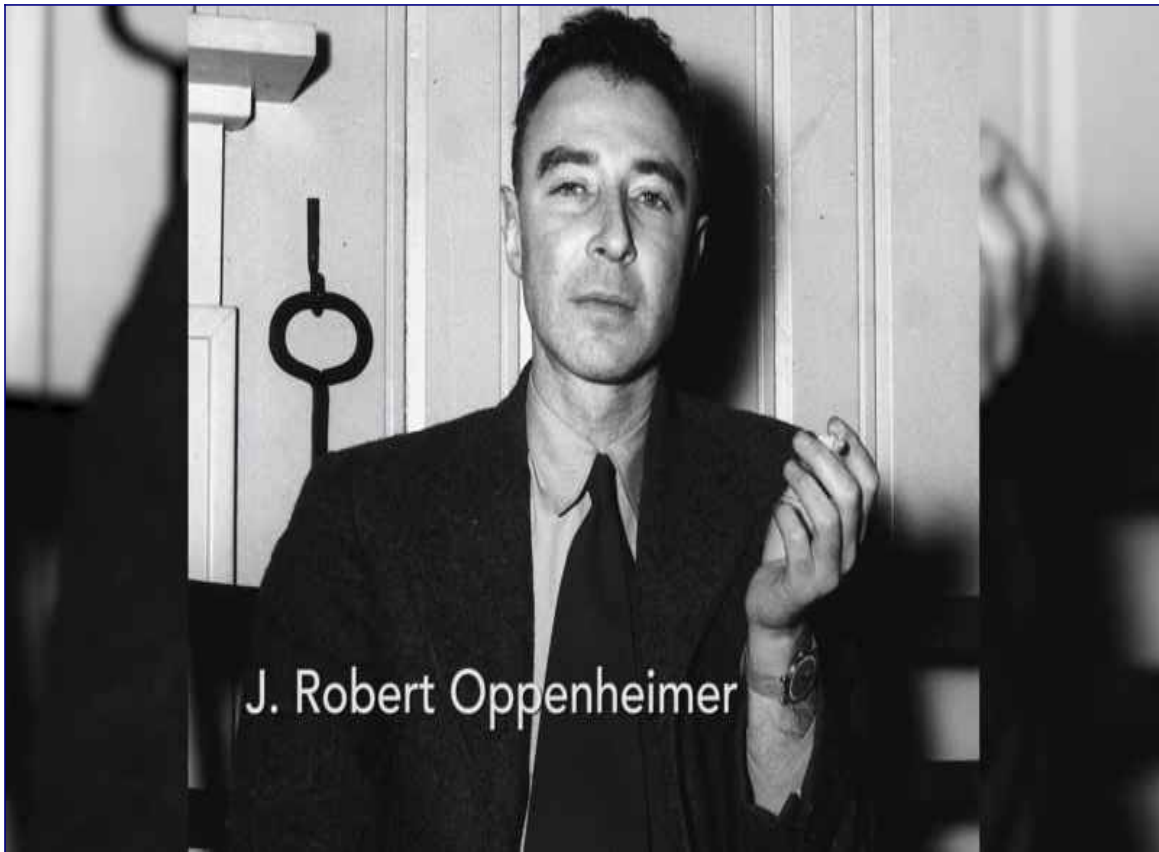

J. Robert Oppenheimer

MEET BOYD

Boyd Bushman: My name is Boyd Bushman. I'm a senior scientist from Lockheed Martin. I have 27 patents. Approximately 13 years ago, I ran across a person who had been given a job by Dr. Teller. Dr. Teller was Oppenheimer's right-hand man.

And even after Oppenheimer was thrown out of Area 51, Dr. Teller stayed there and was in charge of several programs.

The person that I contact twice to three times per month is the head of that program now, and they continually update me on everything they possibly can. I do have a top secret clearance.

I choose, however, for their purposes, not to use it because they – the intelligent ones of me and me – actually believe that a great deal of information should be lifted up from those dark recesses of Area 51 and moved over so people can see it.

So that's what began about 13 years ago.

Since I am a scientist, I do not believe in theory. I basically, say, "Follow the data; theory be damned." If something can't verify by a physical test that something is true, then I do not care to accept it in that [information] that I present.

Therefore, everything we present here will be data that comes directly from them, through me, to you.

* * * * *

David: He's talking about the idea that Teller was working with a group of insiders and that they now want to disclose the truth. So is this something that happens fairly often in these classified programs, that people actually do want to get the information out?

Corey: Yes, it's fairly common. And whoever is doing security of these groups know that. They've done personality profiles on these people. They watch them very closely. They're watching for body language, different micro facial expressions. They're watching them very closely to know whether they need to step in.

So a lot of the times, these guys will usually have these conversations, you know, at a Sunday cookout and sit around and talk about it instead of talking about it at work.

And eventually, they end up getting found out, for the most part. It's very rare that they don't find out that they're talking about it “outside of the office”, as they say.

David: He said in there, “I have a top secret clearance, but I don't choose to use it.” What do you think he meant by that?

Corey: If you go in and work under a top security clearance, you're bound, legally, by everything you agreed to when you signed the agreement for the security clearance.

So if he's trying to work, he's trying to skirt the security clearance and any retributions that may happen legally or with his pension. So he's playing kind of a little game.

David: Now, when this interview came out, as I'm sure you remember, it lit up even the mainstream media like a wildfire. There were a lot of articles that were written about this, covering this guy.

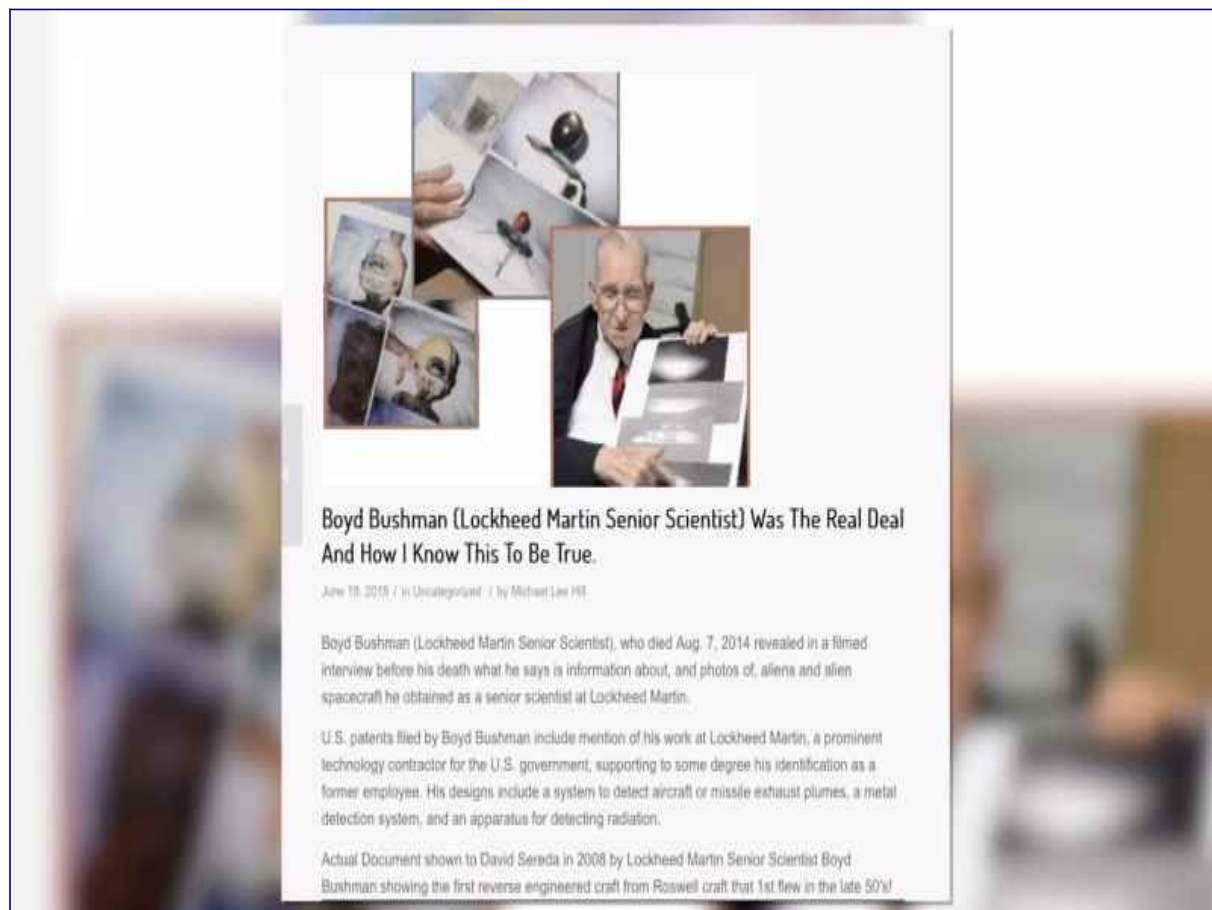

BOYD BUSHMAN, LOCKHEED MARTIN SENIOR SCIENTIST TELLS ALL, BEFORE HE DIES [VIDEO]

Posted by stevev | Mar 4, 2017 | 2017, Conspiracy, Cabal, and Government, Daily Blog, Science and Suppressed Technology, Video | 0 ● | *****



Former Lockheed Martin engineer from Texas: I met aliens at Area 51

By Joshua Fechter | Published 2:07 pm, Thursday, October 30, 2014



Photo: Fechter, Andrew / YouTube



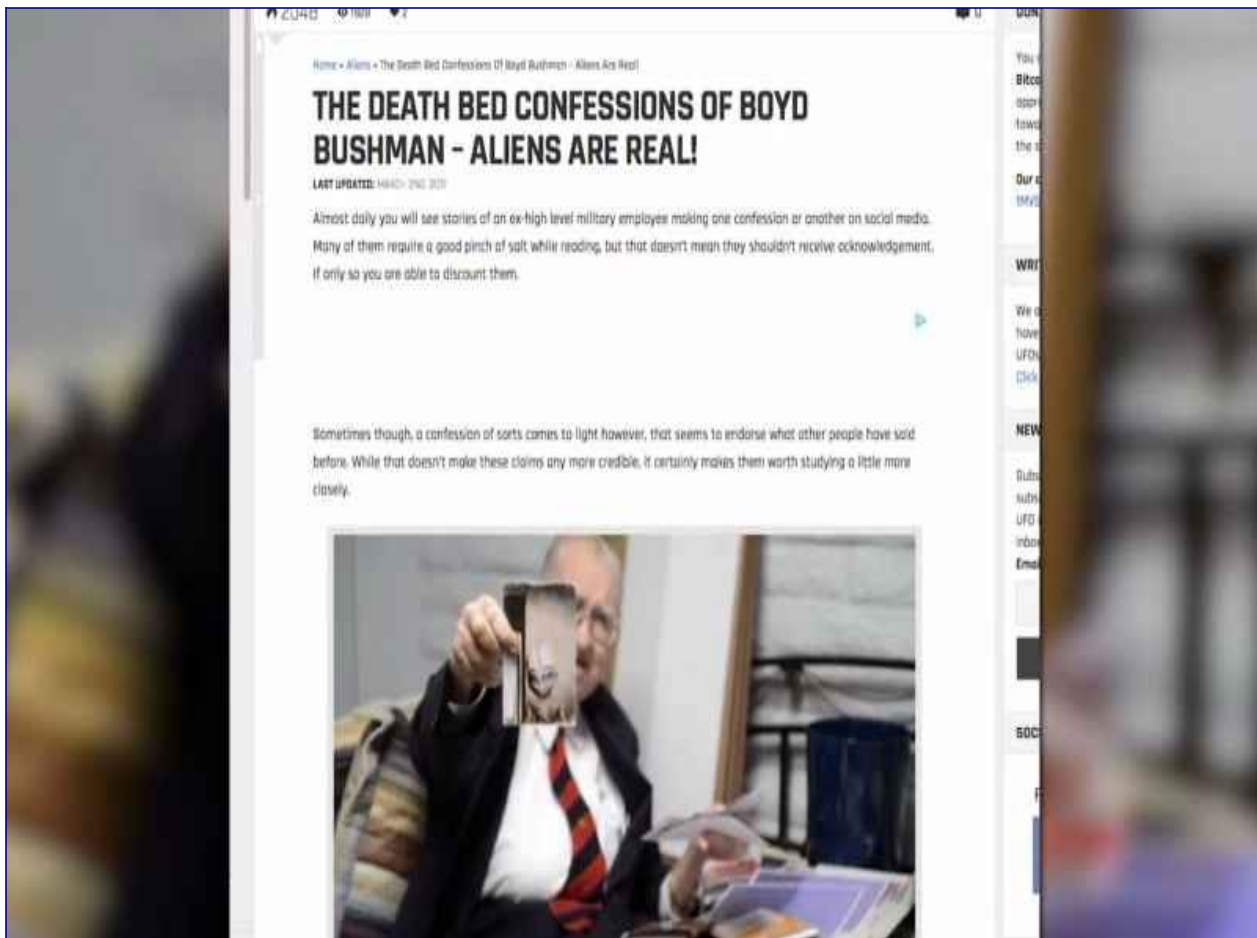

So that, to me, suggests that he is not working as some rogue, but that what he's doing here was perhaps part of an orchestrated plan. Do you think that's true?

Corey: Well, it very well could be, because the groups that I was describing prior, the ones that don't get caught, are the ones that find like-minded people in security that turn a blind eye to the talk.

These are the types of people that really got this SSP Alliance rolling.

David: Right.

Corey: You know? That's how it got rolling.

David: What would be the objective of articles about this man and what he's going to say as we go through this episode, being released to the public?

He does seem to have the credibility. He says he works for Lockheed. We're going to see some pictures of extraterrestrials, allegedly.

What would be the ultimate endgame of promoting these videos and his testimony in front of the whole world?

Corey: Well, the Alliance anyway, and as well as the – whoever we want to name – the shadow government, they've been seeding the consciousness of humanity through movies and, you know, comic books, people giving deathbed statements like this.

So they kind of want to – in a way that they can distance themselves from or deny – deliver this information in bits and pieces to our subconscious.

David: He said that he worked for Lockheed, and he has 27 patents.

Corey: That should be easy to verify, unless they're . . .

David: That's what I'm thinking.

Corey: . . . one of the 5,700 classified patents.

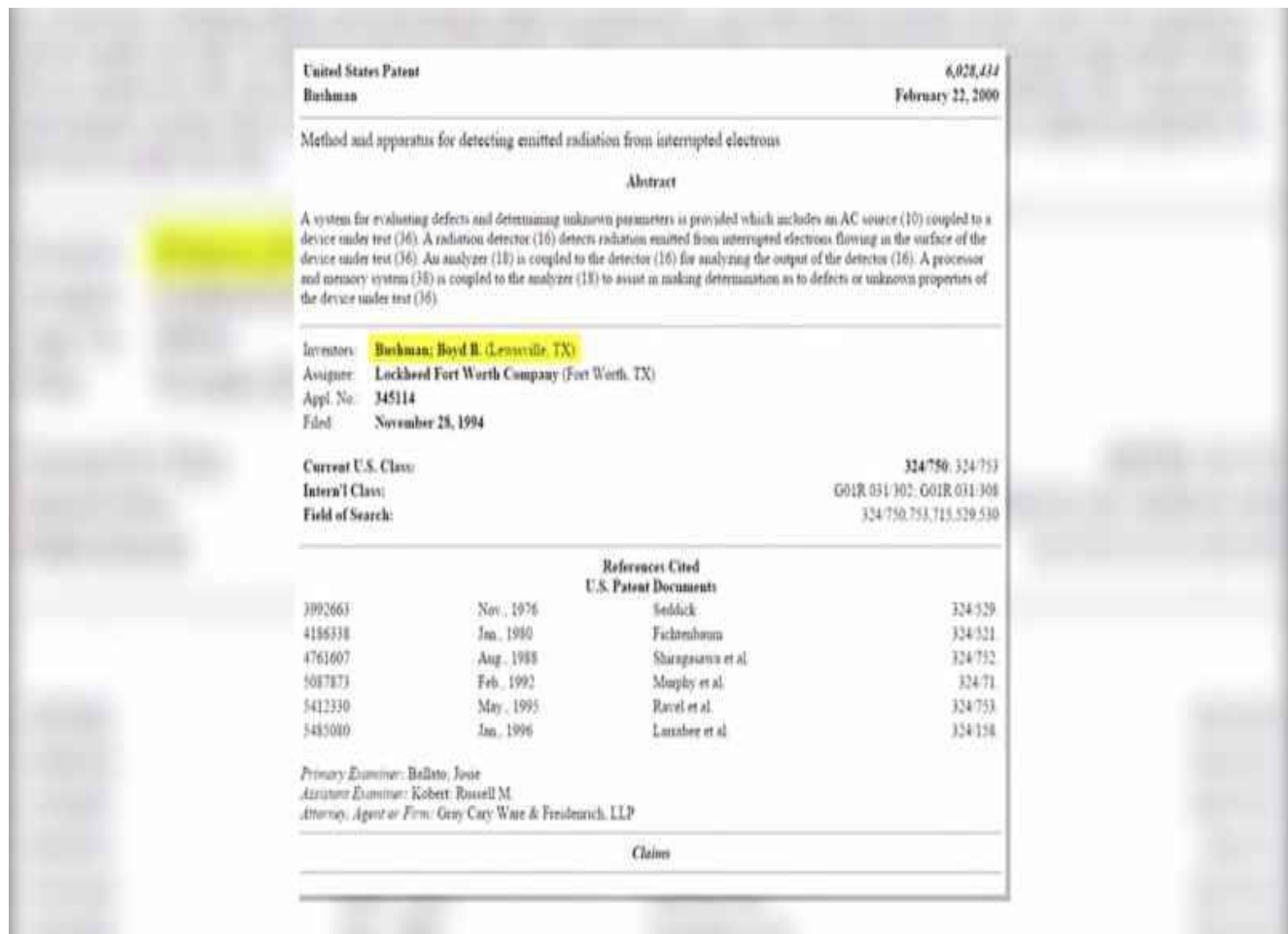

David: Now, the reason why I bring this up is, can you verify that these patents might be held under national security, and therefore we might not be able to find them because they could be classified technology?

Or might there be enough things Lockheed is doing that are unclassified that at least some of those patents could be tracked down?

Corey: Yeah. A good deal of their patents are unclassified, but the most sensitive ones end up being among that 5,700 or so patents that are classified to this day.



The image is a screenshot of a web page from Justia Patents. The page has a dark blue header with the 'JUSTIA Patents' logo and a search bar. Below the header is a navigation menu with links for 'Find a Lawyer', 'Ask a Lawyer', 'Research the Law', 'Law Schools', 'Laws & Regs', 'Newsletters', and 'Legal Marketing'. The main content area shows a breadcrumb trail: 'Justia > Patents > Patents by Inventor Boyd B. Bushman'. The title of the page is 'Patents by Inventor Boyd B. Bushman'. Below the title, there is a section for a specific patent: 'System and method for electromagnetic propulsion fan'. The patent number is 6606578. The abstract describes an electromagnetic propulsion fan with a hub, fan blades, a rim, and magnets. The patent type is 'Grant', filed on March 1, 2001, and granted on August 12, 2003. The assignee is Lockheed Martin Corporation, and the inventors are J. Kirston Henderson and Boyd B. Bushman.

David: So then, if someone is trying to fact-check this, they might find some patents. They might not find all 27, but it's likely that at least some of these should be able to be tracked down.

Corey: Yes.

Apparatus and method for amplifying a magnetic beam

US 5929732 A

ABSTRACT

An apparatus and method for creating a magnetic beam wherein a focusing magnet assembly (45) is comprised of a first opposing magnet pair (20) and a second opposing magnet pair (30) disposed in a focusing plane, each magnet of the respective opposing magnet pairs having a like pole directed towards the geometric center of the focusing magnet assembly (45) to form an alignment path, two like magnetic beams extending from the alignment path on each side of the focusing magnet assembly (45), each beam being generally perpendicular to the focusing plane. A like pole of an unopposed magnet (10) can be directed down the alignment path from one side of the focusing magnet assembly (45) to produce a single magnetic beam extending generally perpendicular from the focusing magnet assembly opposite unopposed magnet (10). This beam is a magnetic monopole which emits pulses, levitates, degausses, stops electronics and separates materials.

IMAGES (3)



Publication number	US5929732 A
Publication type	Grant
Application number	US 08/842,850
Publication date	Jul 27, 1999
Filing date	Apr 17, 1997
Priority date	Apr 17, 1997
Fee status	Lapsed
Inventors	Boyd B. Bushman
Original Assignee	Lockheed Martin Corporation
Export Citation	BIBTeX, EndNote, RefMan
Patent Citations (9), Referenced by (7), Classifications (13), Legal Events (5)	
External Links	USPTO, USPTO Assignment, Espacenet

FIG. 3

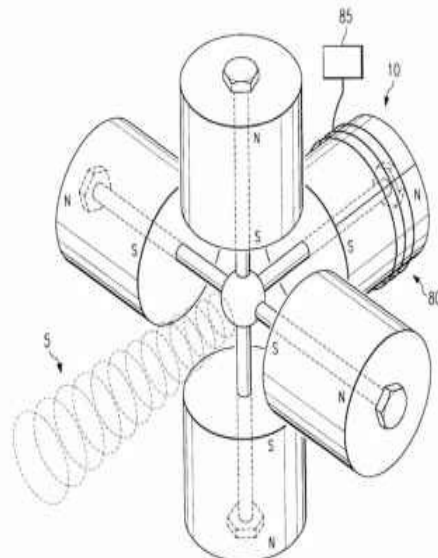

David: Many of these insiders, such as **William Tompkins**, and people he's spoken to, are told that, “Oh, just calm down. You know, the things that you're working on, we're going to release it in 10 years.”

Then 10 years go by, nothing happens.

How does that influence what we're seeing now with this guy coming forward, when he's been told by the doctor that he might only have weeks to live?

Corey: Well, that is very common, telling them “a decade – it's a decade away”. That was told to a lot of people in the programs that I was in.

David: Really?

Corey: A lot of them who had a conscience wanted to know when is this information going to be given to the public? And they also wanted credit for what they've been doing. They want the public to know what they've been doing.

David: Sure.

Corey: And they were told that, “You'll be a hero someday. Everyone will know 10 years from now.” And they keep kicking the can, and a lot of these people become very disillusioned and become ripe to become members of the Alliance.

David: How is the Alliance able to contact people in this position without getting outed if there's so much surveillance? How are they able to do it?

Corey: It's usually people that are friendly within the security apparatus of these different groups. That's usually . . . If you want to start some sort of subversion, you need to first infiltrate security or police.

David: So you're saying it would then happen as a verbal conversation with, like, somebody who's allegedly a security guard?

Corey: Oh, yeah. Only mouth to mouth. You know, mouth to ear, mouth to ear.

David: Is it possible for people to send letters to each other? I heard recently, that the U.S. post offices, they might not read your letters, but they are now scanning everybody's mail and seeing who you're sending mail to.

Corey: No, it's not advised to have anything in writing. You know . . .

David: Really?

Corey: Yeah. You pass information down the chain, which can be unreliable, kind of like the telephone game. It goes through different people's filters, and then they kind of tweak it a little bit, but you don't want to have anything written.

David: When we were talking before the show about some of the validation that's now showed up recently for Boyd Bushman, it seems that it comes out of this Vault 7 leak recently that took place.

So for those who have not been actively paying attention to that, since it did seem to go by pretty fast in the media, could you explain for us what the Vault 7 story is and how it relates to Disclosure?

Corey: Yes. Vault 7 was a data dump done by WikiLeaks on the CIA.

David: And my understanding is that there's 8,700 documents in this Vault 7.

Corey: That's a very large dump.

David: Yeah. The thing that shocked me the most was when WikiLeaks came out with this and said that 99% of the stories that there are to be found in there have not yet been made public. And we had Drudge Report calling this another Snowden.

What would be the purpose of releasing information from classified CIA documents? And how does that relate to Disclosure?

Corey: They released a lot of names in this Vault 7 data dump, and a lot of these names are people that are civilians who have been tracked by the CIA.

David: So Boyd Bushman is in the Vault 7 leaks.

Corey: Yes.

David: And they were watching him and keeping him under surveillance.

Corey: This was a list of civilians who have been surveilled by the CIA.

David: If the NSA is our National Security Agency, which is really national surveillance agency, and that's what they do, why the heck does the CIA need to be doing the exact same stuff but under their own umbrella? That's not going to make sense to most people.

Corey: A lot of these organizations are not completely connected when it comes to data. They're not necessarily all pulling from the same haystack.

They'll have their own haystacks of information. And it is redundant, but these groups aren't fully . . . These groups aren't fully sharing between each other. They go through kind of a committee to share information with each other.

David: One of the things that just came out about Vault 7 was a leak from the highest levels that no one is allowed to work with each other in the CIA for more than three years because they're so worried about individual people on a team starting to form their own little factions.

Corey: Collusion, yes.

David: Do you think that's partly the Alliance and how they're trying to stop the Alliance from being able to grow?

Corey: That's how they're trying to prevent any type of coordinated effort against them.

David: Exactly. All right. Now, let's see the next very interesting piece of the interview done with Boyd Bushman, his deathbed confessional, Lockheed Martin insider. Check it out.

* * * * *

ALIENS ARE REAL

Boyd Bushman: I asked them to tell me about who was flying these things. He, therefore, said, "Fine. They're approximately 5', 4½' to 5' tall."



They had one or two of them around that were 230 years old. And we have a total of at least 18 that exist and operate with our facility as Teller set it up.

And notice the eyes are different, nose are different, but they do have five fingers, five toes, two eyes.

And rather strangely enough, I asked him how they communicate. He says, "Well, it's like this, Boyd. You all of a sudden have a question in your mind. You walk into a room with one of them, and all of a sudden, you find yourself giving the answer to your question in your own voice. They're able to use your own voice by telepathy to talk to you."

And I said, "Fine."

Now, that's how they look from front, but when you turn around and look at the back, it's like that.



Now, notice that they have three back bones. They're actually cartilage. Nevertheless, it's a much more efficient system than ours.

They also have three ribs in their system, rather than more. This is also the back side of an alien.

Here's a 45° look.



And, now when we talk about aliens, I pushed the issue, and he said, “Well, there's kind of two groups of aliens.” They divided them into two groups. One group he calls . . . it's like you have a ranch. And you have a ranch, and you find that one group are your wranglers that know how to wrangle your cattle.

There are others who are rustlers, ones that steal your cattle.

And indeed, the two groups do act differently. The ones that are wranglers are much more friendly and

have a better relationship with us.

Here's the other side of the alien, too.



Now, also notice that their feet, where they have five toes, the toes are joined together like a frog, yet they are dissimilar.



And this is the home planet that they come from, which they call Quintumnia.



And notice that the hand . . . that's an alien hand.



Notice that the fingers are longer than ours by quite a bit, about 30% longer, and that's just the way they're put together.

* * * * *

David: Well obviously, there's a lot of very interesting stuff we can talk about in this one excerpt alone.

One of the things that he said, that I think even the people writing the articles didn't really catch, was he mentioned the number 18.

And it sounded to me very much like when he said that there were at least 18, that he was talking about different types of extraterrestrials.

That's a much smaller number than what you were aware of. However, would someone maybe just working as an engineer for Lockheed only be given a number around that size as part of this compartmentalized security?

Corey: Yes. And he most likely found out about the majority of them towards the end of the time he spent as an engineer or after.

They usually let you know of three, maybe eight, different types, depending on what technology you're reverse engineering, what technology you're studying.

They're not going to let you know more than you “need to know”.

David: Let's just say that one of those guys is watching our show, and maybe you can show him that there might be more than he thinks he knows. So what might those three to eight groups be? What would he have been told, necessarily?

I mean, they could change but . . .

Corey: Oh, yeah, it could change. Some of them know about Reptilians, but some of them don't.

David: Okay.

Corey: It's interesting. Some of them have been told about this Eben-type group.

David: Okay. Which would be what?

Corey: Some people associate them with the Greys, but they look very fleshy. They're bipedal, fleshy beings. You know, their eyeballs aren't black unless they have lenses in.

Then you have these Nordic groups.

David: Okay.

Corey: Mostly, they'll know about that, or the Tall Whites. But for the most part, they'll know about those. And some of them seem to know about the Reptilians, but some of them don't.

David: Now, there's going to be controversy right up front with the Boyd Bushman stuff because all these kids on the Internet thought that they win the Nobel Prize for discovering that this ET picture that he's holding up was actually just a photo of a toy from Walmart.

Corey: Right.

David: The toy from 2008 looks exactly the same as the pictures that he's holding up now.



So many people on the Internet have tried to – as the skeptical debunkers – think that this guy literally just took a toy and took pictures of it. How do you answer that?

Corey: There is the possibility that this toy was released in a limited edition to preempt any disclosures of this type of alien.

Now, I've mentioned to you in private, I believe, that I've seen these types of beings, and I've seen them alive.

David: Right.

Corey: And they were referred to as “Oranges”. And when they were alive, their skin color was sort of carrot-colored, but it was darker – carrot-colored with a little brownish, I guess. But they called them “Oranges”.

And they were very positive beings. When they're alive, if you've ever had a pet bird or seen a bird that has died, their eyes recess into their head quite a bit.

David: Right.

Corey: And when they're alive, their eyes are out from the head. And then the little wrinkly areas under the eyes and above their eyes, they're very, very . . . in the eyes, the energy's very pleasant.

David: Mmm.

Corey: And their eyes articulate around quite a bit, and you see the wrinkles that go under the eyes and around the eyes push out and move around as the eyes are kind of out from the head a little bit – barely.

David: So you're saying that the Orange has a much different look when it's alive than what this desiccated corpse is.

Corey: Right. They have been here to try to assist us. I guess they would be one of the wranglers.

David: That he mentioned.

Corey: That he mentioned. They've been here trying to help manage us, manage the planet, you know, sort of like watchers.

David: Some people who are not very well informed would say that any type of ET that looks like this is a Grey, and that it is abducting people and torturing them and putting probes in them and implants in them. How do you answer that in terms of what you're saying these guys are doing?

Corey: Well, there are a number of beings out there that have loosely the same description as these Greys.

David: Right.

Corey: So there's a lot of confusion. You know, there's even a Reptilian-type species that has the same body configuration and sort of look that these Greys have.

And in the rehab, the people that had had contact with these beings, the military would reabduct them, and a lot of times the people would tell them that they were Greys because they had seen so many different TV shows, and they've seen that outline image of the Grey so many times that they try to connect them all together because they look similar.

David: You also mentioned that guys at a lower level of security clearance, who were still nonetheless Top Secret, would be told about Nordics. We've discussed Nordics living inside the Earth.

What would the typical boiler plate, lower level disclosure of Nordics involve? What would they be told they are? Where do they come from? What are they doing?

Corey: Well, not all Nordic beings come from Inner Earth.

David: Right.

Corey: Some of them actually come from other stars and have been in a millennial-long battle with the Reptilians and have had skirmishes with other beings and civilizations, as well.

There has been a galactic war – if not intergalactic war – that's ebbed and flowed and happened in history, way back before humanity even existed.

David: So that material science guy working at Lockheed Martin, working on surface texture, whatever, that kind of stuff, okay, what is he told about Nordics based on what you just said? How much might he know?

Corey: It just depends on his need to know. Whatever technology he's working on, he only needs to know what he needs to know to interface with the beings or to know that it's associated with a certain being, to have an idea of what type of approach was taken to the technology development on their planet.

Other than that, unless he's worked multiple programs and got to know of multiple ETs, he's just going to know of what they tell him for what he needs to know on his job.

David: He mentioned something about cartilage being the way that the bones are made, and that they only had three ribs, and that there was an unusual structure in their back.

Are there some ETs that have more of a cartilage skeleton instead of a bones skeleton like ours?

Corey: Yes, a cartilage-like skeleton, but a lot of them are not . . . the whole skeleton is not cartilage. They just have features. Like we have cartilage in our nose.

David: Right.

Corey: They might have different protrusions or other things that are something similar that was a part of whatever they were before they evolved, like the webbed fingers.

David: Now, he mentioned something strange about telepathy, which was that not only do you experience telepathic communication as soon as you walk into the room with these beings, but that you hear it as if it was your own voice speaking to you.

What are your thoughts on that?

Corey: That's exactly how it occurs. And it'll make you wonder when you're having ideas and thoughts, where are they coming from? You know, it could be another source outside of yourself.

But, yes, the communications I have, everyone has that one voice that they sort of process hearing in their internal monologue. That's the same voice you hear them communicating with you.

And you also get images, smells, tastes, depending on the being.

David: He also mentioned that these beings had a planet of origin that he called Quintumnia. I'm curious if you ever got into enough of a dialogue with these Oranges, as you called them, to hear anything like that, or if there are, in fact, names of planet and things like this that pop up sometimes.

Corey: Yes. They will give names of their planet, which is obviously from their location. It's not some sort of English translation of where they're from. This very well could be the name that they have given to their planet. That's the first time I've heard it.

David: So if he's saying that he was made aware in briefings, it appears that he was made aware of 18 groups at least, and he's saying that they neatly divide into two major categories.

Category one: wranglers. Category number two: rustlers, which would actually be those who steal your cattle.

Corey: Right.

David: This sounds an awful lot like the galactic slave trade you've mentioned. So I'm curious about your thoughts when you saw that part of the video.

Corey: That's correct. And during the time that he was getting his briefings, most likely a lot of that was going on heavily before we had developed the Secret Space Program far along enough to where we could, I guess, warden – Solar Warden – our own territory.

But yes, they would come in and scoop people all the time, and then shoot out of our Solar System real quickly. And even the nonterrestrials that were monitoring things, it sometimes would happen so fast that they couldn't respond.

David: How long do you think people in the United States' defense establishment were aware of this going on before they had the technological means to stop it?

Corey: They've been . . . Since the inception of an intelligence community, they've known.

David: And when did they gain the capability to stop this from happening?

Corey: That would have been probably in the early '80s that they would have been able to show enough force to stop it from occurring consistently.

David: All right, our next section of Boyd Bushman's interview is coming up right now with a lot more fascinating information. Let's take a look.

* * * * *

AREA 51

Boyd Bushman: I do, because of some very good reasons, keep things within control, but I don't want us all behind the Russians and Chinese. And the problem I have is that Area 51 is working with both the Russians and Chinese right now trying to make UFOs.

There's been a total of 39 United States citizens that have lost their lives, trying to reverse engineer UFOs.

And, well, the last one I heard of was a year and a half ago, where we lost 19 lives in one test. They actually wanted to bring various flying craft near the UFO, and the UFO defended itself, and 19 of our people died.

* * * * *

David: How do you think it would have felt to somebody like Boyd Bushman, working probably during the Cold War obviously, and then knowing that Russians and Chinese are actually jointly working with the US at Area 51?

Corey: The people that were fighting the Cold War, so to speak, were heavily indoctrinated in the anti-Russia mentality. That's what drove them in doing their engineering was keeping America safe from any type of nuclear exchange with Russia.

David: Well, China wasn't as much of a . . . It wasn't considered as much of a threat in the '80s as it is now, but why would China be at Area 51? What's really going on here?

Corey: We got to a certain point in our Secret Space Program to where we couldn't hide it from the other technologically evolved nations. They were tracking us.

So not only did we have this Global Galactic League of Nations that was set up, but in . . . I can't remember the time period, but I think it was in the '90s, some sort of an agreement was signed between

these powers that they would share technology.

They're exchanging scientists to make sure there's a continuity of technical information going to all of the different groups. It assures that they're all sharing what they have.

David: What would the purpose be for apparently being in a nuclear showdown with Russia in the world but then very nicely collaborating with them at Area 51? Why would there be such a division?

Corey: Well, the collaboration with the Russians during the height of the Cold War openly in these bases was . . . you didn't see it that much. It was towards the end of the Cold War, most of it after the Cold War, when we started making agreements with China and Russia and India and some of these other groups.

And we also have people from India and a couple of other nations that we work closely with and share technology with, because we found out that they were getting pretty far in their development, as well.

So sharing this information is also a way of managing it if you have agreements between all of these different nations.

David: Now, he mentioned 39 people losing their lives in the course of working on UFOs, but then he also said 19 people died when they flew with conventional flying craft towards a UFO in the sky, and it apparently defended itself.

Let's break these things down. So, first of all, the number 39, based on all the stuff that is really known, seems very, very small.

Corey: He could have been just quickly passing over without giving much detail. It could have been 39 Lockheed employees that have worked on these programs that he knows about.

David: Right. Wouldn't you think, though, that the total number of people who lost their lives trying to back engineer UFOs would be a lot higher than 39?

Corey: Absolutely. There have just . . . We've lost a lot of lives just retrieving the craft before we're able to begin reverse engineering them.

David: Wow!

Corey: So, yeah. Lots of lives have been lost retrieving them, reverse engineering them. And then we have back during the German Secret Space Program when they developed it, we had a lot of Germans dying in the process, a lot of scientists dying producing these technologies, not to mention all of the slave labor they had.

David: All right. In our final section of the interview footage from Boyd Bushman, we have a very interesting Roswell-like incident that he tells us about.

* * * * *

BATTLE OVER NEW MEXICO

Boyd Bushman: Turned out to be a doctor. He was a very, very fine gentleman, and I was carrying on a conversation with him. He saw how the subject was going, so he simply said, “Well, you need to know what I did one day.”

And I said, “Okay.”

He said, “I was in the process of doctoring a pilot who was a test pilot, Navy test pilot, for the United States government, and it was 1947.”

He basically told me that he was . . . that “they, the radar group, had found a blip out over New Mexico, and that they would like to assign me to go out and check it out.”

So he says, “Fine. I’ll do that.” And he got the fastest airplane that existed then, which was a propeller at that time. And it was fully armed and all the rest of those things.

He was out flying, and he found the item, and he immediately communicated back, and he said, “I wish authority . . . First of all, I want you to tell me, are there any other airplanes flying? Are there commercial or anything else around other than he and I?”

They said, “Just the two of you.”

And he said, “Fine. Second thing I wanted to know is do I have authority to shoot it down?”

They said, "Why do you want authority to shoot it down?"

He says, "Because I am flying the fastest thing that the United States can make, and he's beginning to leave me. Therefore, I know he's either a friend or an enemy, and if he's leaving me, he's an enemy. Therefore, I wish authority to shoot it down."

The commander said, "Fine." He granted him authority.

He pulled in. He shot him down. It came down.

He flew past and saw that there was a road on the one side of the fenced area. He came down and landed his airplane. Hard to do, but he did. And then he cut across the fence.

One of them . . . The door was open. One of them was out, walking around, but he didn't care about that. He cared about what the vehicle was.

So he went over, and rather strangely enough, when he ducked down – because they're only 5' high – he saw that he could see through the walls. Not only that, but as he stepped in, the floor was spongy.

He look at the three that were there, and they were dead. He knew they were. He'd killed them. But he also knew that the military would come, and he'd put up with those guys for a long time.

So he went over, went back across the barbed wire fence, got in his airplane and took off.

When I got up with my contacts in Area 51, I brought up that story, and they said, "Well, that's totally true, but we can't say it. You can."

* * * * *

David: All right. So this is clearly a story that gives us detail into the fact that there are vulnerabilities to these ETs. They are not necessarily like the Battle of Los Angeles, where this thing's got a shield around itself as our military is firing at it and nothing seems to have happened to it.

Some of these craft, apparently, can be shot down. Is that, in fact, true?

Corey: Yes. And if you catch them at different stages in their flight – and I don't know what those stages are – they are vulnerable to high energy, disruptive weapons. Like they said, the radar may have taken down the Roswell craft.

So a lot of these can be taken down with high energy weapons. It's rare that you hear of them taken down with a kinetic weapon.

I don't know if a missile was used. It sounds like it might have been hot lead that took them down.

David: Right.

Corey: So that would be a very rare occasion. I would be speculating why they were able to not only get that close to get within range of this craft to be able to shoot without them taking evasive maneuvers.

So I'd have to speculate what was going on at the time with the nonterrestrial craft.

David: He mentioned when he went inside the craft that the wall became transparent, and you could see all around. Is that a normal thing for one of these?

Corey: Yes. Oh, yeah. Yeah. That is very common. You will see no windows, but everywhere from inside a craft, you can see. It looks like there are no panels at all, like you're just looking out through an open area.

David: Is it common for stories like this to get passed around, like scuttlebutt in maybe cafeterias, and this kind of stuff?

Corey: That's usually after a couple of beers in a bar that they feel comfortable talking about that. Usually beer is involved.

David: Ha, ha, ha. All right. Well, that's all the time we have for in this episode, giving you a unique insight into Boyd Bushman, who was widely publicized in the media with this unique testimony, clearly intended to be part of an ongoing disclosure to bring us the truth.

I'm [David Wilcock](#) here with **Corey Goode**, and we thank you for watching.

Cosmic Disclosure: Zero Point Energy and Advanced Propulsion Technology

Season 7, Episode 22

David Wilcock: All right. Welcome back to “[Cosmic Disclosure](#)”. I'm your host, [David Wilcock](#). So, **Corey**, welcome back.

Corey Goode: Thank you.

David: So I've got to say that when I saw this interview footage, the first one we're going to watch here, he actually mentions the name of a guy who I knew very well.

And **Mark Comings** is one of the only people I've ever met who literally could run rings around me when it came to advanced physics.

And so when you and I are talking, you know a lot more about Secret Space Program stuff than anybody else I've met, except for a few insiders.

Mark Comings is one of those guys, but in the physics arena. So this really shocked me to hear him mention that name because I know so much about this guy we could talk about him for two hours.

So without further ado, let's hear the first thing that **Mark McCandlish** has to say, and maybe you'll understand why I was so surprised once you see it yourself. Let's take a look.

* * * * *

CHASING FREE ENERGY

Mark McCandlish: I met a scientist who has since sort of taken himself out of circulation. He's vanished. His name was **Mark Comings**.

He was a physics professor working as a teaching assistant at UC Berkeley, in their physics department.

And he had been . . . He'd become aware of the fact that in the basement of the physics building on campus was a lot of this old surplus equipment – frequency generators and oscilloscopes and power generators – all these different kinds of things.

So he asked the head of the department if he could go down and just tinker and do some experiments. He had some ideas he wanted to play around with. And they gave him the okay.

So he had this idea that, as you may know, there are certain kinds of crystals, like quartz for example, that . . . It's the whole basis for the original phonograph record, the stylus.

When you would put a small crystal – I think it was like a diamond crystal – under pressure, it would create a mild electrical current. And if you amplify that current, you could then hear what the impulses were coming through that stone, that gem. And you could actually hear the vibrations that were recorded in a disk of plastic. That's how the phonograph works.

And so his idea was that, okay, crystals, when they're put under pressure – physical pressure – will create an electrical charge. But he wondered if you augmented the process by putting electrical coils that wrapped around the crystal, and you essentially applied an electrical pressure to the crystal, that the crystal would do not only the same piezoelectric process of creating an output of electricity, but that it might actually be more than what you would get with just putting physical pressure on it.

That by taking advantage of the lattice – the crystalline structure of this object, this stone – that you could then get it to resonate in a way that would kick out even more energy than you were putting into it.

And so he had a barium titanate crystal. It was about eight inches long, double terminated – in other words, a point on each side – had a cross-section that was kind of like a stop sign, sort of an octagon shape, had it fabricated by a facility outside the San Francisco Bay area where he lived.

And he had two different coils. One had a lot of fine windings, and another coil wrapped around the outside of that, all completely insulated, that had a lower number of windings.

And he experimented with putting a variety of different electrical charges, different voltages, frequencies, in different combinations, until eventually one night, about 1 o'clock in the morning, working late on this apparatus, the crystal began to glow a bluish-green, and it began to ring.

You know how when you're at a wedding, and you take your glass – your wet finger on a champagne glass, and it makes that high pitched ringing sound? He said it was like that.

And he looked at the scale – the dials on his equipment that showed input voltage and output voltage.

And this thing was putting out 125% more – in other words, everything it was getting plus an additional 25% over and above what he was putting into the crystal.

Of course, he was very excited, you know, took his notes, shut everything down, went home, went to bed. And by 8 o'clock the next morning, his house was surrounded by black SUVs and guys with ear buds and dark glasses.

They kick in the front door. They tossed the whole house. They arrested him. They confiscated all his notes. They confiscated his equipment.

And they basically said that they'd found a closed circuit TV system that he'd set up to view some of the women in the Phys Ed building, the locker room, the women's locker room in the next building. And, you know, he was in trouble.

And they wouldn't tell him what he was being charged with. They kept saying, “You know what you're charged with. You know what's going on here.”

And the reality of the whole thing was that he had created an apparatus that had accomplished what is supposedly impossible.

And I asked him, I said, “When you did this, when this thing finally worked when you found all of the right ingredients to make it work, do you believe that this thing put out some kind of a footprint in the environment that someone in the know was listening for and were ready to clamp down on?”

He said, "Absolutely, without a question." He said, "Somebody triangulated my position, found out where I was, found the equipment, got ahold of the administration of the university, and they were at my house by 8 o'clock the next morning."

That's how fast it was. And so he's gone into hiding. And I've heard that he's working somewhere in the Far East.

He's well-funded and continues his research, but all underground.

* * * * *

David: Well, **Corey**, this is a very emotional thing for me actually, because first of all, I knew **Mark** Comings before he went into hiding. We actually spoke on the same stage at a conference I was doing in Portland in 2003, called "Time and Global Shift".

And he wouldn't tell me what he had invented that caused these guys to come to his house. So seeing **McCandlish** go into detail about what the invention was, was a first. I had not heard . . . I just heard about the bad parts.

So let's talk about that first. Is there, in fact, some sort of energetic signature like **Mark** and I also talked about personally, that we theorized had been released when you build one of these types of devices that they could detect?

Corey: Yes. And that is how they track, also, a lot of the nonterrestrial and human craft within our solar system.

It is used as a way of doing air traffic control to be able to locate the vessels producing this signature. There is indeed a signature that is put off in a limited spectrum that they are always listening for on the Earth and also in space.

David: Is there any place safe in the world for somebody to develop this technology? Or could the Cabal hit you basically at any geographical location on Earth?

Corey: When it comes to developing it, yeah, there are plenty of deep, dark holes you can hide in to develop it. And you have to acquire everything that you're going to use – all of the different types of technology – you have to acquire it very quietly.

If one person starts acquiring certain technology, red flags go off.

So you can find a place secure to develop it, but the minute you're successful, they're going to know because of this energy signature that they can pick up.

David: Right.

Corey: That's why they watch these people very closely, very important that they develop a personality profile on them so they can decide which way to approach them.

Some people, you know, the almighty dollar. If they go and offer them \$1 billion, they'll sign over the patent very quickly.

Others, who are more principled, they have to threaten their families. They have to lean on them. And sometimes, ultimately, these people will die of strange cancers, heart attacks, strokes, suicide.

David: It sounds like you're describing a different type of what John Perkins wrote about in his classic book, “Confessions of an Economic Hitman”. And he called it “The gun or the money campaign” . . .

Corey: Um-hmm.

David: . . . where he'd walk in with a gun in one hand and a bale of cash in the other, and say, “I'm giving you one of the two of these before I leave here. Which one do you want?”

Corey: Yes.

David: Same basic idea, huh?

Corey: Same basic idea. And, I mean, if it's going to work in that situation, humans are so much the same, they're going to be able to use it for the free energy sector as well.

David: Another story that **Mark** Comings told me was that in another group that was aware of this kind of thing happening, they tried to build a free energy device where each component was built

separately and the plans were kept separate.

And then only right when they were going to test it would they have each of the guys bring a different piece of the machine together, build it on the spot, test it, then break it down and take it away.

But even in that situation, he said they still got popped.

Corey: Well, it's easy because there are satellites that are covering almost every square inch of . . . well, every square inch that is important on the Earth.

So if they came together real quick, put this device together, turned it on, and then The-Powers-That-Be got this signal ping on their device – they call it a ping – and then these people take apart the device and then scoot, well, they're going to be able to go and rewind – just like a videotape where this satellite was tasked, at what time – and go to the right satellite, find the footage, and then track the people back to where they came from.

David: It's very interesting that **Mark** Comings is describing the crystal glowing. So I'm curious if you ever witnessed glowing crystal technology in any of the stuff that you saw.

Corey: I saw the scientists working with different types of crystals and stones and stuff, and I saw very small crystals that were square, obviously man made, glow when a field was applied to them.

And there were . . . Nothing physically was touching them. So, yeah, I've seen that.

David: If they give you, let's say, billions of dollars, and you take it. Do they then kill you later, or do you actually get to live out your life?

Corey: Very quietly live your life, probably on a remote island.

David: All right. Well, with that in mind, let's now see this next piece of interview footage with **Mark McCandlish** discussing the interesting and scary politics of free energy. Take a look.

RELEASING FREE ENERGY

Mark McCandlish: Actually, bringing the technology out and making it available is something that's going to require all of the precautions that we started to implement when we went from the horse and

buggy era to automobiles – you know, car crashes, or people going too fast, or spilling gasoline, and fires.

But, you know, the technology, if it's properly implemented, can give the petroleum industry the ability to take all of that chemistry and use it for other things that are much more valuable in terms of their return on investment.

There'll have to be a time when the scientific community as a whole is going to get together, and they're going to have to acknowledge that the technology is real.

There's been enough experiments, enough patents done now, that anyone who's really in the know, who understands what the implications are of the technology, is going to understand that if a scientific consortium, a group of scientists, came together and they outlined a plan to implement the development of the technology in a way that it could be used safely – safely for the production of energy, with the sole purpose being to save the environment from all of the impacts of the pollution that's created by fossil fuels, especially the nuclear power industry after the wake of Three Mile Island, Chernobyl, and now Fukushima.

I mean, there are people now that are saying that in 20 years, the Pacific Ocean could be dead because of all the cesium 137 that's being put into the ocean.

And if we can use the technology to produce power and not have to worry about nuclear power and the fallout, and the terrible footprint of nuclear waste, then I think we'll be so much further ahead. I think the environment will really benefit.

* * * * *

David: So regarding this question of clean energy, I think you and I both agree that it is being suppressed for a variety of reasons.

What would you say are the main reasons why this technology isn't being allowed to go out there despite its awesome usefulness for the problems that we have?

Corey: Most of these patents have been classified for one reason. The reason is that if the free energy was released to the public, it's going to collapse the economy because the energy sector is a very, very large part of the economy.

What truly is the reason is that those who control the energy sector don't want to lose their power and income. So we are being denied these technologies just because somebody wants to get paid.

Another aspect of this is you'll have someone try to reproduce one of these free energy devices. And if it is known, remotely they can create an imbalance in the field of where the people are doing the testing, and things that should normally be repeatable – experiments that are repeatable – won't work.

So they're able to affect it remotely as well – affect people's research.

David: All right. Now, we're going to have some footage from **Mark McCandlish** in which he's describing not a reverse engineered situation, but an actual extraterrestrial craft and the attendant circumstances. Let's take a look.

* * * * *

UNDERSTANDING ZERO POINT ENERGY

Mark McCandlish: Since I found out about the Alien Reproduction Vehicle, one of the things that I began investigating was the whole business of alien abduction, and alien contact, and this kind of thing, because my thinking was that if these people really were having encounters with beings from another star system, there might be a chance – however slim – that they were taken aboard these vehicles, and they might have gotten a tour of the ship.

They might have had an opportunity to see some of the components of the ship.

And I really got pretty lucky, because one of the three young ladies who I investigated very thoroughly, did, in fact, make that claim, that after she had gone through some very horrifying tests to determine whether she was a threat to the beings on this vehicle, they did, in fact, give her a tour of the ship.

And one of the areas that she went into was an area where the central part of the propulsion system was

located. And many of the components described were remarkably similar to the ones in the Alien Reproduction Vehicle.

There was a central column. There was evidence of counter rotation, just like in the Bell. There was a small disk, very similar to the item that's in the Alien Reproduction Vehicle. But in the Alien Reproduction Vehicle, this thing is . . . it looks like the floor of the vehicle. It's about a nine foot diameter disk that's under the ejection seats.



But on the alien version, this thing's only about two to three inches larger in diameter than the central column. And the column was made out of a glass-like substance, just like the materials used in the ARV. It was sitting in a pit in the middle of a circular room, and the perimeter of the room was kind of a walkway with a railing at its edge.

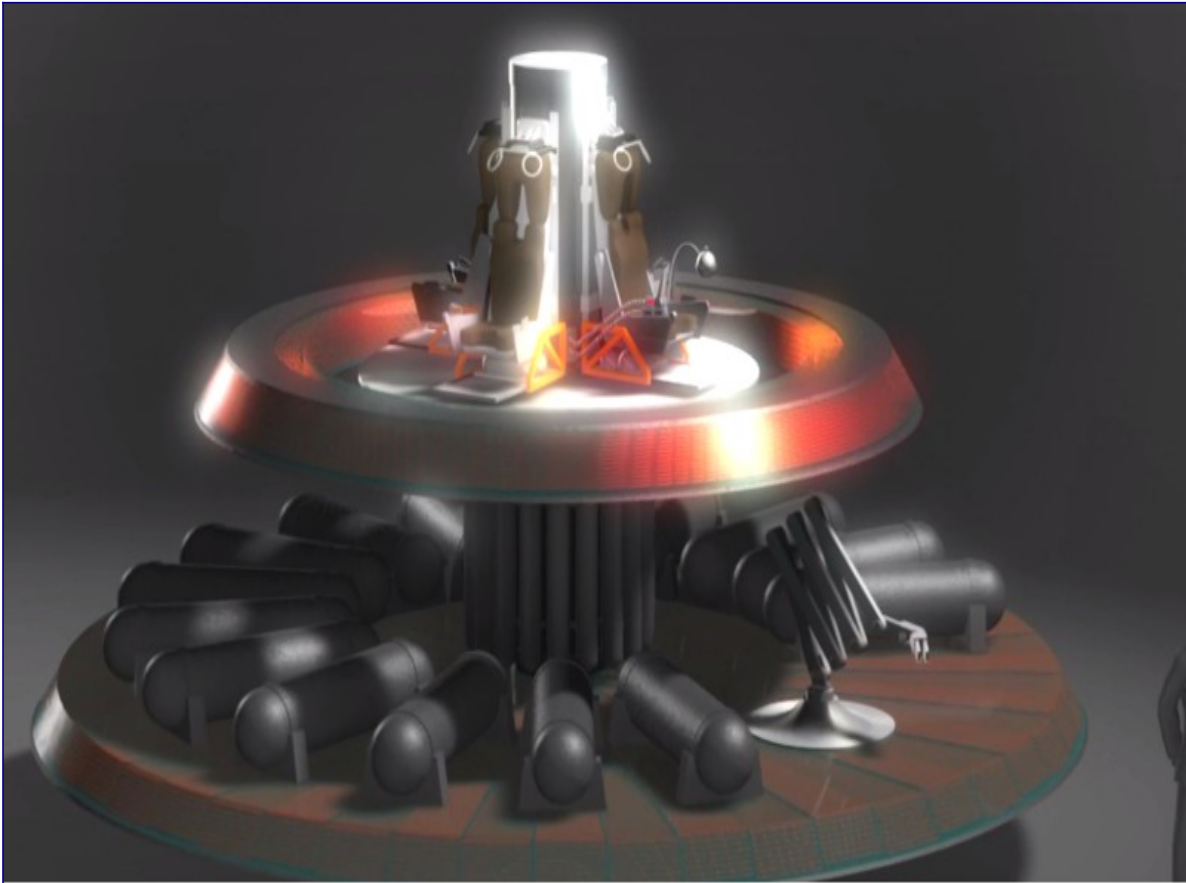
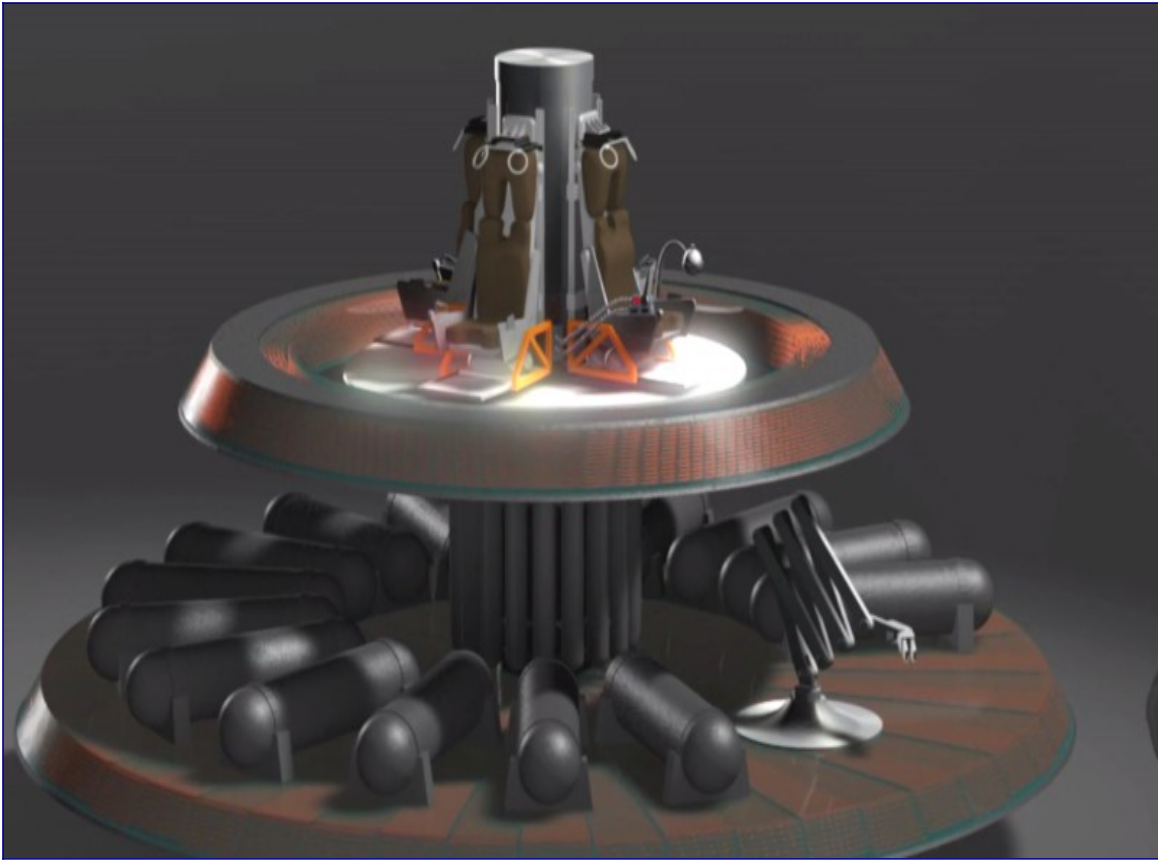

But she said that when she looked down into the pit and across the far side, she could see that beneath the floor was this glass-like substance with these coils embedded, just like the ring of coils around the crew apartment in the ARV.

But the thing that was most fascinating about her description was that in the central column, with the little disk at the bottom spinning in one direction, the column itself spinning in the opposite direction, that there was a silvery metallic-like fluid that was inside this column that she could see under the glass.

And it had these little flecks, shiny flecks and dark flecks of material that were sort of swirling around, but she said you could see the turbulence pattern in the liquid.

And the turbulence pattern looked like a series of five little tornadoes that were spiraling up around the inside of this column.

What she was witnessing is very much like what you see when you get an F5 tornado. You have the big one in the middle that's going 150 miles an hour. It's tearing up everything in sight.

And then a lot of times what you'll get is a series of smaller tornadoes that are rotating in the opposite direction, almost just like a planetary gear drive. And they're orbiting the main one in the middle.

And the turbulence pattern that she was seeing in this column looked just like what you would see in those little sister tornadoes that would orbit an F5.

And so that told me that inside this column was a shearing effect, where two things are moving past one another like that, which means that there's another cylinder on the inside moving in one direction. And then there's a cylinder on the outside moving in the opposite direction.

And that shearing effect is what was creating these like miniature tornado-type structures on the inside.

So then, the fluid itself can be seen moving upward. So that begs the question, okay, where is it going?

Well, if it's a closed loop system – and this sort of fills out some of the details of the Die Glocke, the Bell – is that if the fluid is moving upward, then it has to be coming back down somewhere.

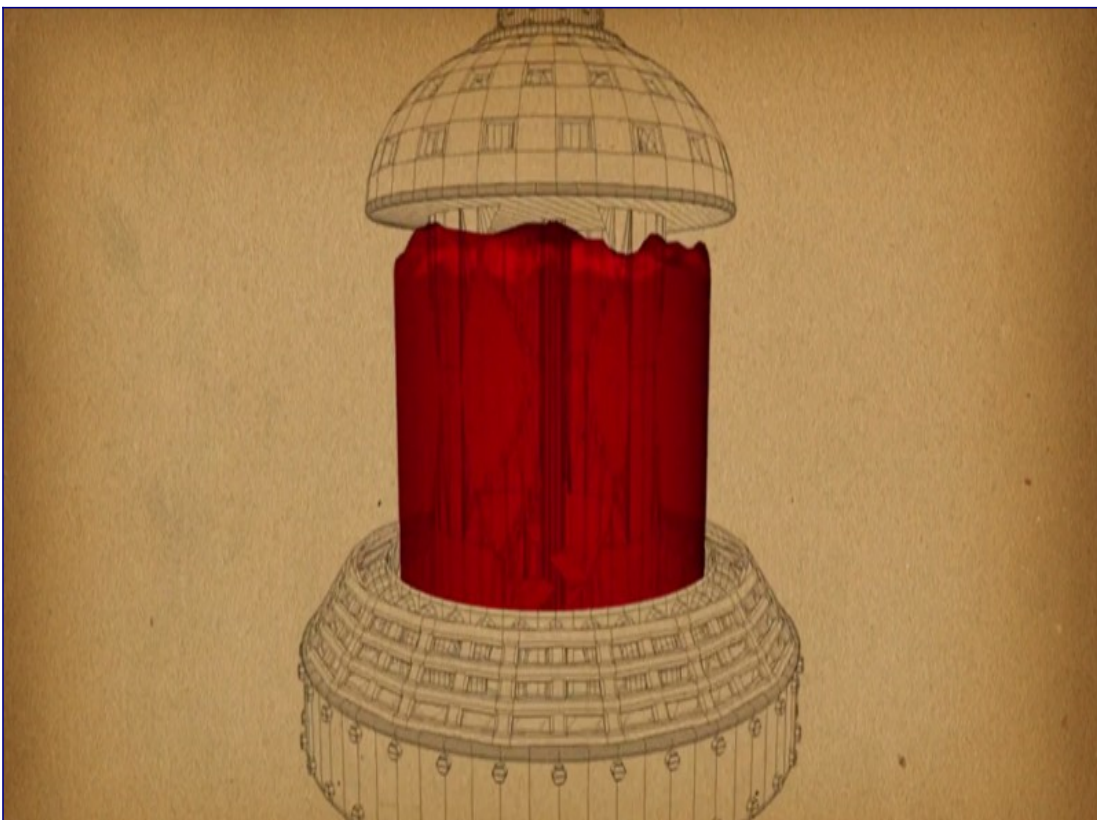
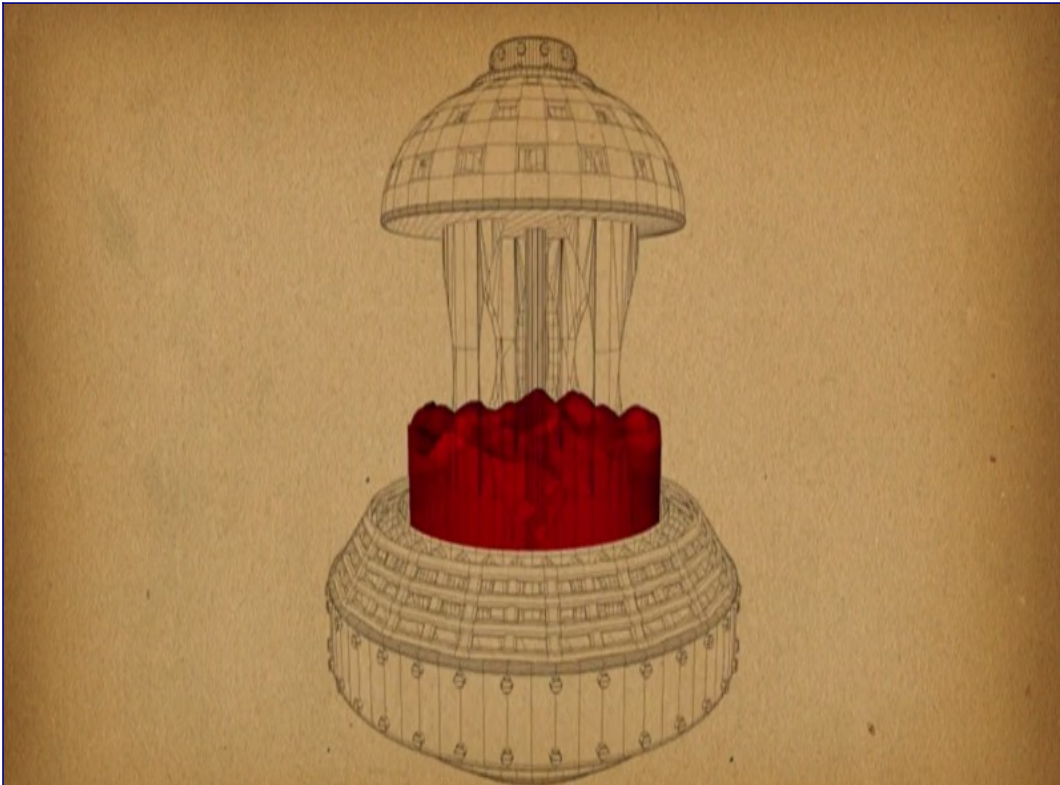

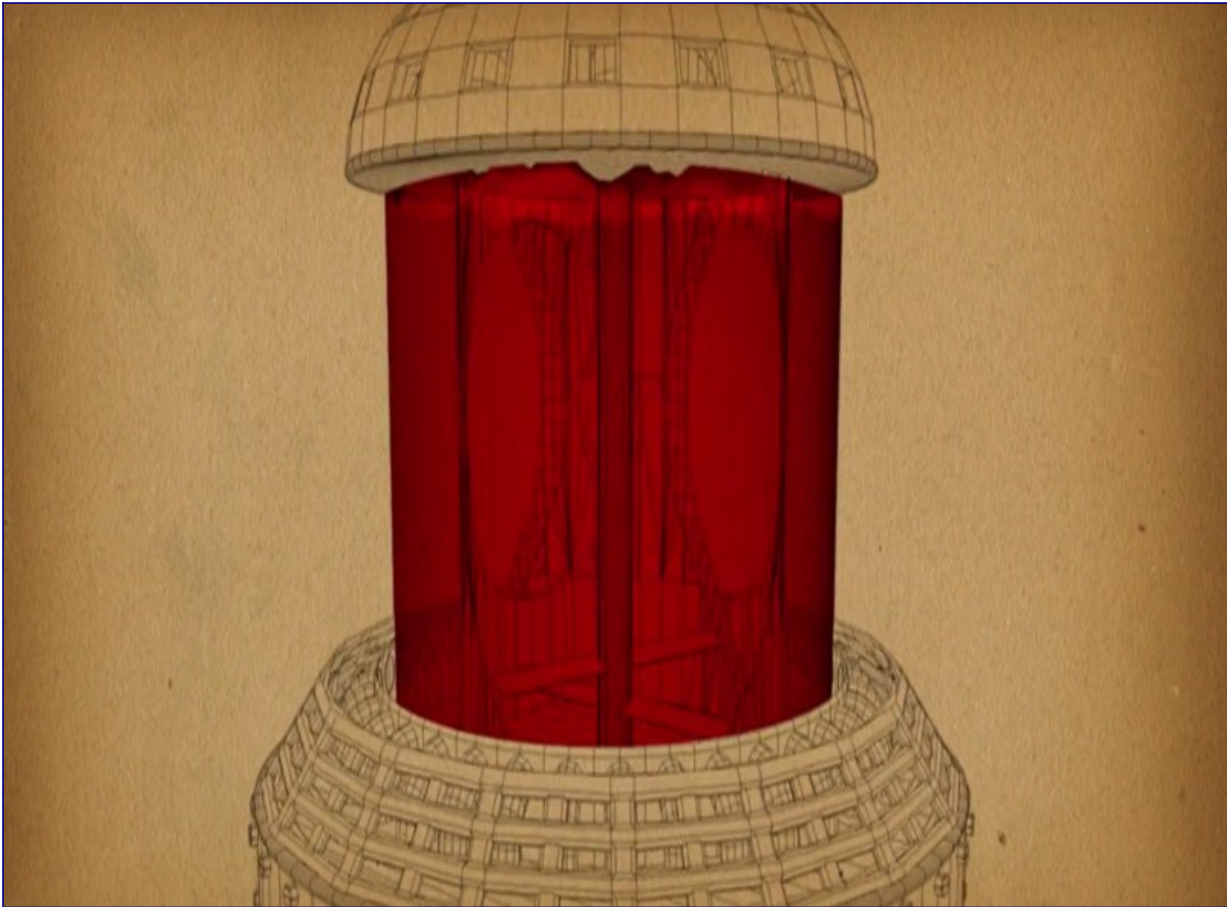

And the answer is it's coming down through the middle. So it's a closed loop. It goes up through the edges between the two cylinders and then down through the middle.

And if you're having this tremendously powerful electrical discharge that fires through that liquid, and it's done in just the right way – if you shape different parts of the system in such a way that it's like a venturi, like a funnel at the top – when you fire electricity down through the center of that funnel – because you have a ring shaped electrode and then a cone shaped electrode in the middle – you get what amounts to an artificial ball lightning.

Ball lightning has been modeled as a torus, as a donut shape, in the laboratory. They've done this.

And what happens when you create this kind of an event with high voltages, is in this donut shaped event, you have the ions that are not only moving around the perimeter of this donut shape, but they're also moving in and out, precessing around the perimeter of this donut shape.

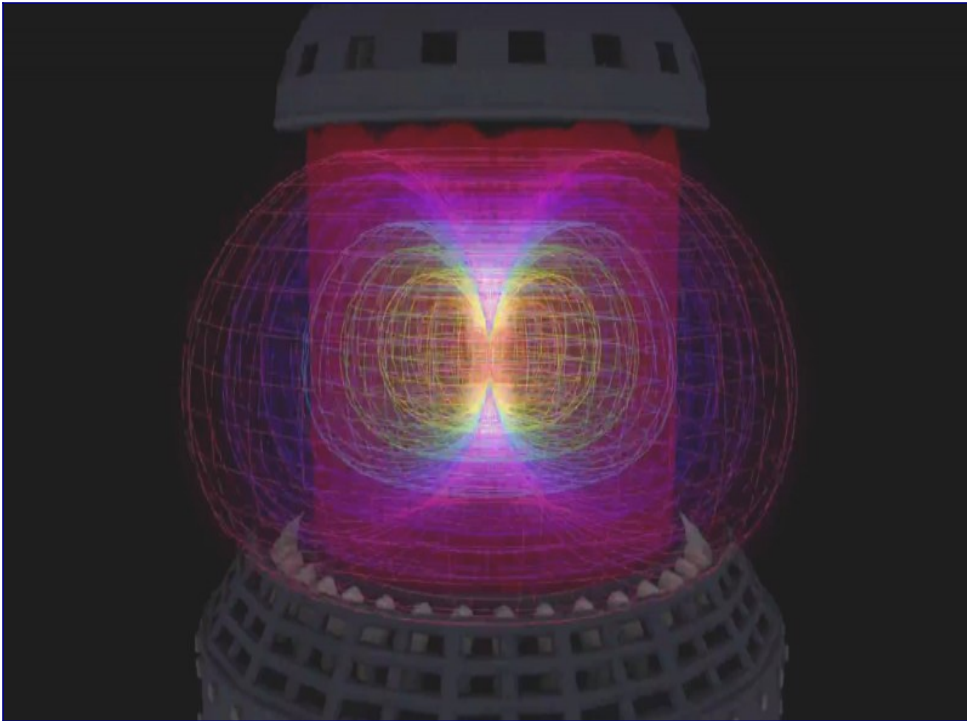

And they create a powerful electromagnetic field.

So what you have in this device is an electrical discharge that creates what amounts to a smoke ring of ions that shoot down through the column. The outer edges are basically stroking through the whiskers of this electrode and giving off all the power that's essentially being drawn out of the vacuum of space-time.

And that's how they're drawing the zero point energy out of the vacuum – is with this system.

* * * * *

David: Well, that's remarkably technical. And all kinds of lights are flashing in my head as we listen to him say these things, because you are one of the people who've mentioned a mercury-based propulsion system.

But given how many specifics he said, and that you've never actually spoken to him before, how much truth is there in what he's saying based on what you know here?

Corey: He's explaining it way better than I ever could. And they . . . I guess in the beginning, we tried using mercury, but they have engineered other gallium metals that are basically liquid metals that

conduct electricity much better, and when being exposed to high electrical fields, don't turn to gold, which is what was occurring when we were trying to use mercury. And I've talked about that in depth in the past.

David: So the essential idea that there is a crystalline-looking tube or waveguide in the middle, and that the mercury or whatever liquid metal is spinning is inside that central tube, and that there's this counter-rotating smaller vortexes outside the larger one, all of that seems true?

Corey: Yes, it's . . . And the donut shapes that go down or up depending on the polarity of . . . that its' . . . which way the plates are spinning. The liquid travels up and then down through the tube and back down through the system.

David: When you say donut shape, are you saying it's a donut vortex in the liquid that you see?

Corey: Yes, it's like a . . . You can see them going up, you know, one after another. And they're spaced out perfectly from each other.

David: When he says ball lightning is formed in the center, does that mean there's some sort of visible, glowing sphere in the center of the tube, or . . .

Corey: He was saying something akin to ball lightning. He was describing these donut-shaped vortices that were coming up.

David: Oh. So do they have a luminosity to them, a light?

Corey: No, it looked like liquid . . . just looked like liquid metal being pushed around with eddies of the same liquid metal within it. You could tell different vortexes.

David: Now, this event that this woman had was being described as an extraterrestrial abduction. Do you think, in light of what we now know, that this might have been from the space program using programmable lifeforms and that sort of thing, given how similar it is to sort of like a more advanced version of the German technology you've described?

Corey: This sounds nonterrestrial to me. A lot of . . . He was describing we had like 9-foot plates, that they had 11-inch plates that would suffice or do the same function, perform the same function.

David: Right.

Corey: And it has to do with how much more advanced they are than us in the material sciences. So they can create a superconductive plate that puts out or handles the same amount of electricity as we do, but they can do it with a much smaller surface area.

David: Why do you think he said there were some black flecks in this material? Wouldn't the material conduct the best if it was a uniform substance or could there be that maybe it levels out the charge with certain particles in certain places by having them distributed like that? What do you think?

Corey: Yeah, that would be a good explanation, that it helps distribute the charge.

David: How common is it for extraterrestrial groups to use this sort of waveguide and liquid metal type of propulsion system where the waveguide is like a tube that you can actually see in the middle of the craft?

Corey: I believe that is fairly common. And it's one of the methods that some of the less advanced groups use. There are much more advanced temporal drives and other types of propulsion systems that are much more advanced than this.

But when you have nonterrestrials . . . When you think of nonterrestrials in the universe, they're at different levels of technological development themselves.

And it is also not unusual to hear about an abductee getting a tour. I've read information about them getting tours, being shown equipment, being shown star maps, being given other information. So that's not unusual either.

David: All right. Next up we have **Mark McCandlish** talking about a very unusual crash story. Let's check it out.

* * * * *

ADVANCED CRAFT RETRIEVAL

Mark McCandlish: I was at a little web cafe or Internet cafe using a computer because my computer had been hacked, so I was borrowing their computer.

And I'm busy checking my email, and off to the side I can hear this conversation going on between two

people who are talking about magnetic ferrofluids – oil-based fluids. They have lots of metallic particles that react to magnetism because they have iron.

And they were speculating about whether it had anything to do with a propulsion system.

And so my ear, my attention kind of picked up a little bit. And the guy was talking about a crash in a vehicle, and I was all, “What are you guys talking about?”

“Oh, we can't talk about it.”

I said, “Well, okay, let me tell you what I know, and then if you think that it's interesting enough for you, you can tell me what you know.”

Well, one of these two guys had been in the Army. He was . . . Apparently, he had been part of a crew, a group, a unit, that had just been formed. It wasn't even on the books, yet.

And it turns out later that's how I found out this is how they conduct a lot of these classified operations is that they create a unit, but before it's ever on the books, before it ever becomes part of the historical record, there are already people operating in that unit. They go out and perform a mission, maybe a couple of missions, and then afterwards, then everything's on the books in terms of the existence of the unit.

But prior to that time, there's no access by the Freedom of Information Act at all, because it officially never existed. And that's what this unit was.

And right at the end of the Cold War, as the Soviet Union was collapsing, and there was a lot of talk of the reunification of East and West Germany, there were double agents – people working for the United States intelligence community that were inside the East German government.

And the assignment that this young man was a part of was to go in, do an insertion into East Germany – you know, all nap-of-the-earth, below the radar, literally – and to collect some of the people that were operating on the inside as double agents because they were really worried that these people might be killed once the government started to collapse.

And they were in the midst of that mission – going to a pickup point to collect one of these individuals – when they were redirected to this crash site.

The vehicle itself . . . And I don't know what the vehicle's called, but I can describe it for you.

Imagine a big, black arrowhead with the blunt end here [leaving one hand by his face] and the long pointy end over here [his other hand is stretched out about two feet].

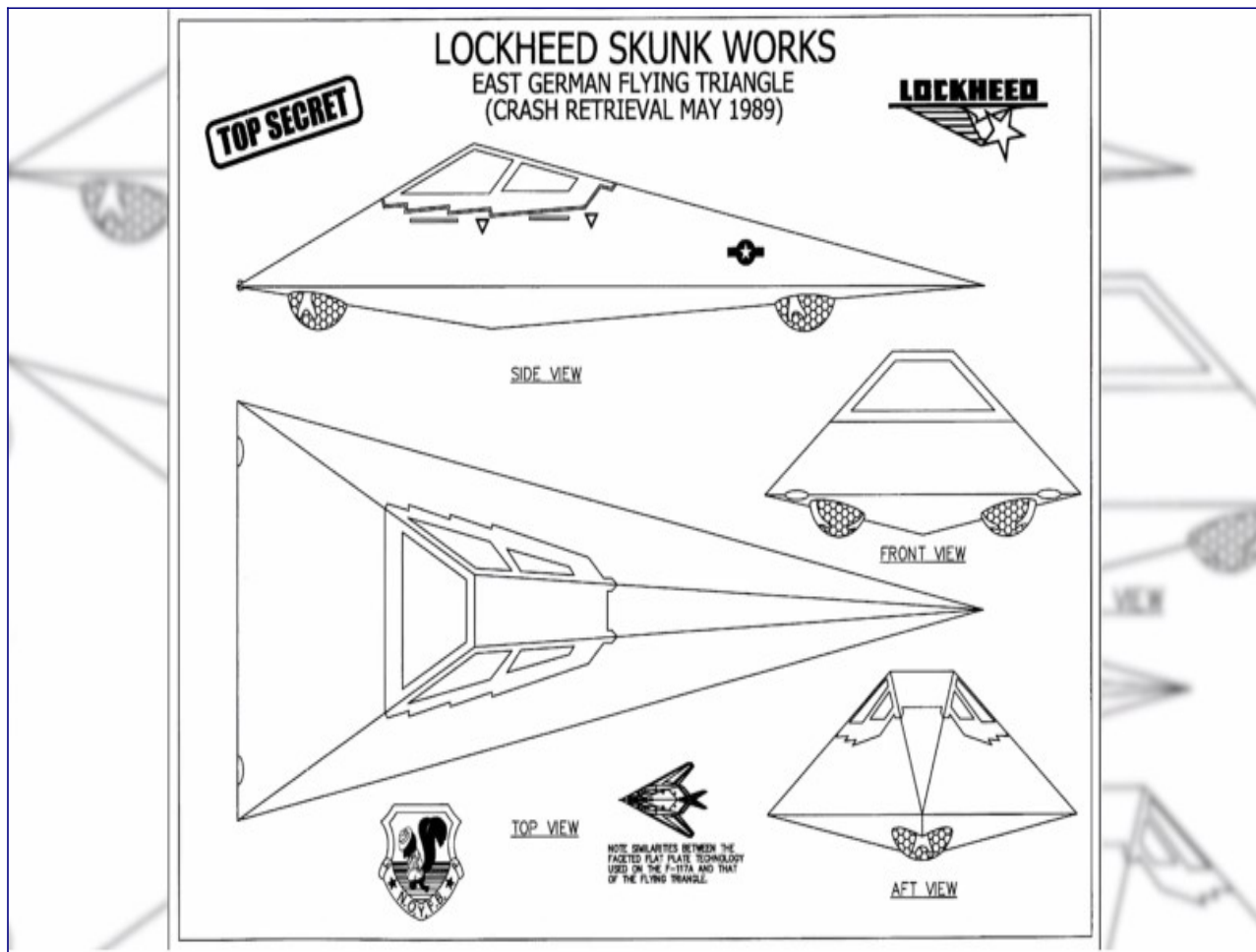

Except that when this thing flew through the air, it flew with the blunt end forward.

It had a cockpit that looked an awful lot like the cockpit on the F-117A stealth fighter with the little sawtooth edges around the windows. And the edge of the canopy had the same kind of sawtooth cutting in the architecture of the vehicle.



If viewed from head on, it would look like a triangle. From the side, it would look like a pyramid that had been stretched out on one of its three corners.

And then under each of the front corners was about a 2½, or maybe about 24~30" diameter white sphere embedded up in the body of the vehicle at each corner in the front.

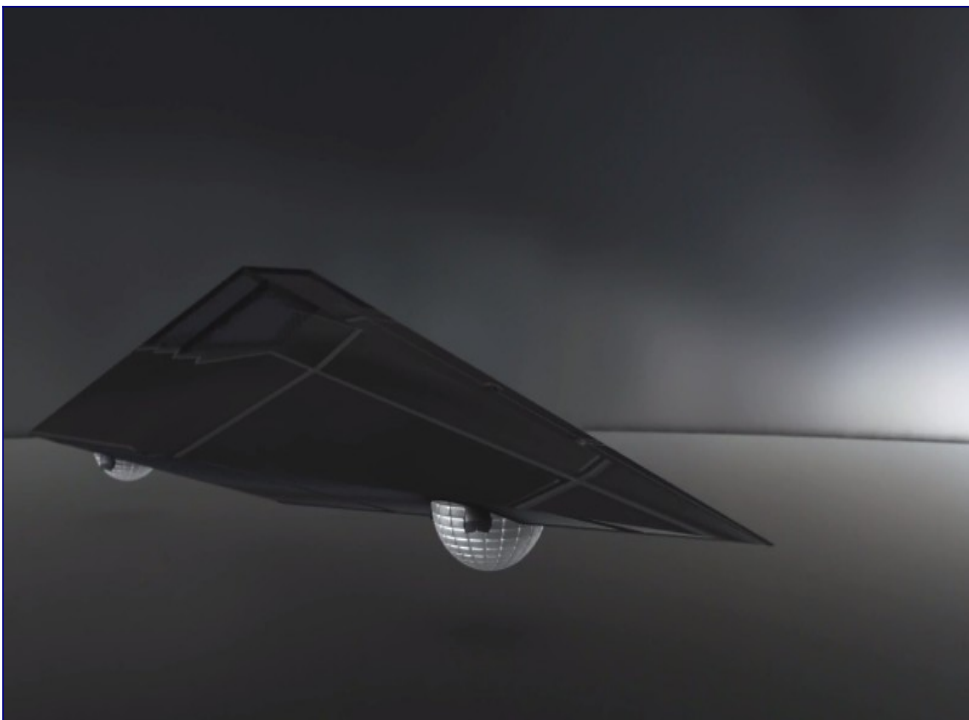

And then about 2/3rds of the way back, on the long point end, there was a third sphere.

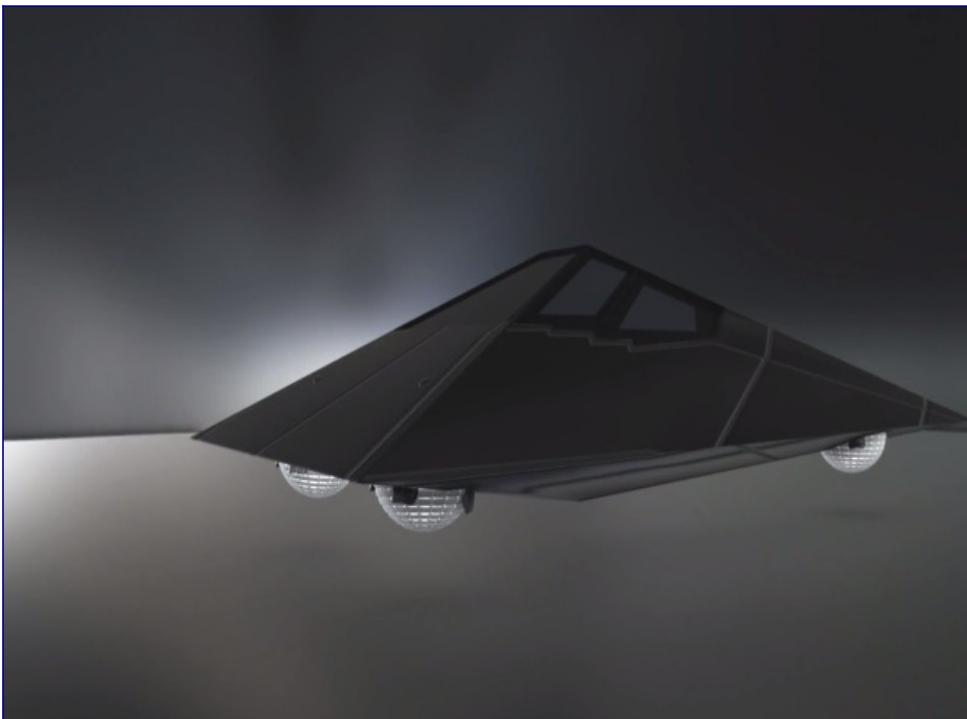
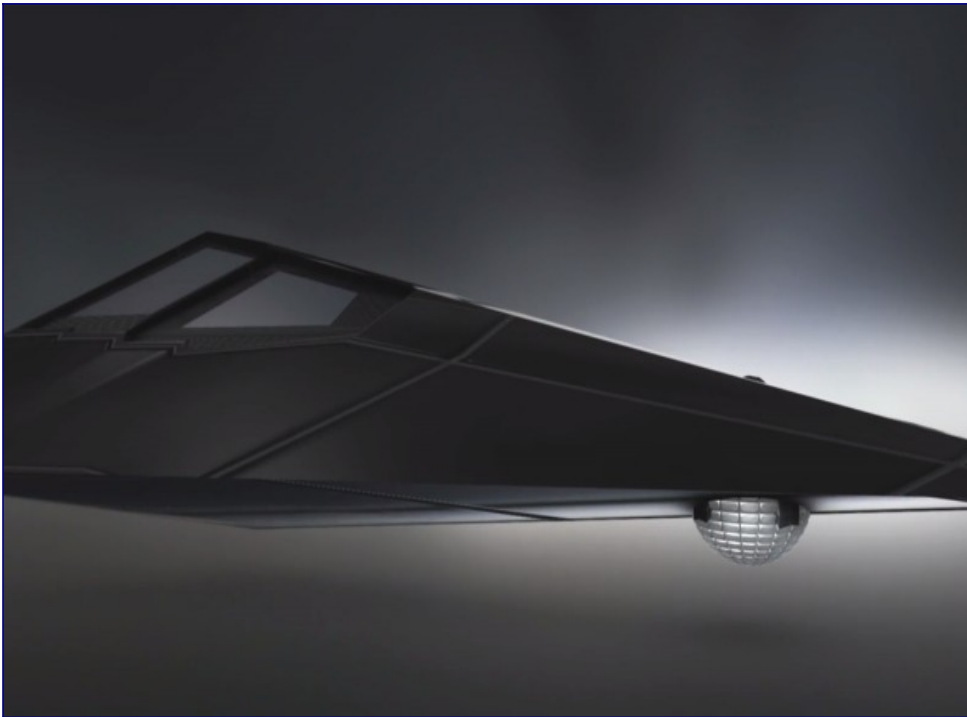

The spheres were held in place by a three pronged clasp, almost like the setting of a pearl in a ring, that was silver, that looked as though it could be articulated and pointed in different directions for perhaps steering control of the vehicle.

By the time he arrived, as part of this salvage operation, there were a couple of technicians with white lab coats, the whole nine yards, taking important components out of the cockpit. They were taking components out, and those were being carried away to somewhere else.

The vehicle had crashed because the pilot was flying some kind of a surveillance mission, was flying nap-of-the-earth using this system, came up through a valley about 10 kilometers southwest of the city of Halle, H-A-L-L-E, in East Germany.

And he came up over a ridge, and he clipped the top of a large pine tree with the left front corner of the vehicle and basically sheared off the corner, crushed the sphere that was at that corner.

And the vehicle immediately began to dive to the left and downward because of the loss of that support, whatever the propulsive mechanism was.

And so in an attempt to not crash, he tried to bank it as far to the right as he could, and he pulled the nose up, and it impacted the hill side anyway. It hit tail first.

And when it did . . . When it hit tail first, it cracked open the structure of the fuselage where that third sphere was in the long pointy end.

And that sphere basically began floating off and was floating around the hill side when they arrived.

And the three-pronged retainer had come off, but the sphere itself was pretty much intact. He described it as looking like a white, ceramic pumpkin with the vertical striations like you'd see in a pumpkin.

But then each of the individual striations had a scalloping, almost like the terracotta tiles on a missionary-style piece of architecture.

So it had this kind of . . . And it looked like the shape was designed to create turbulence patterns on the inside of the vessel.

At the very top was an electrical carry through, metal in color, like a brushed aluminum color, with a number of wires coming out of it.

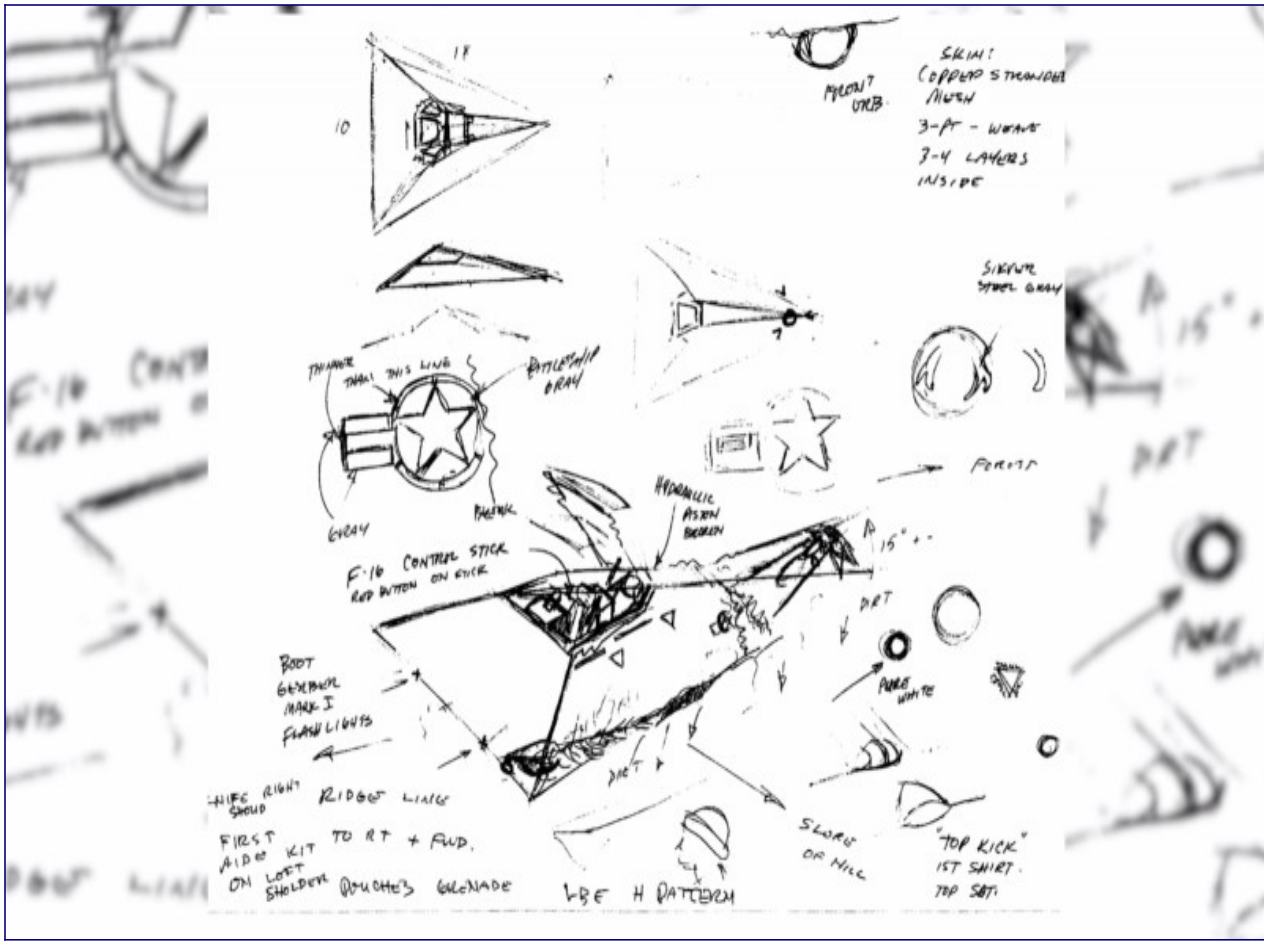

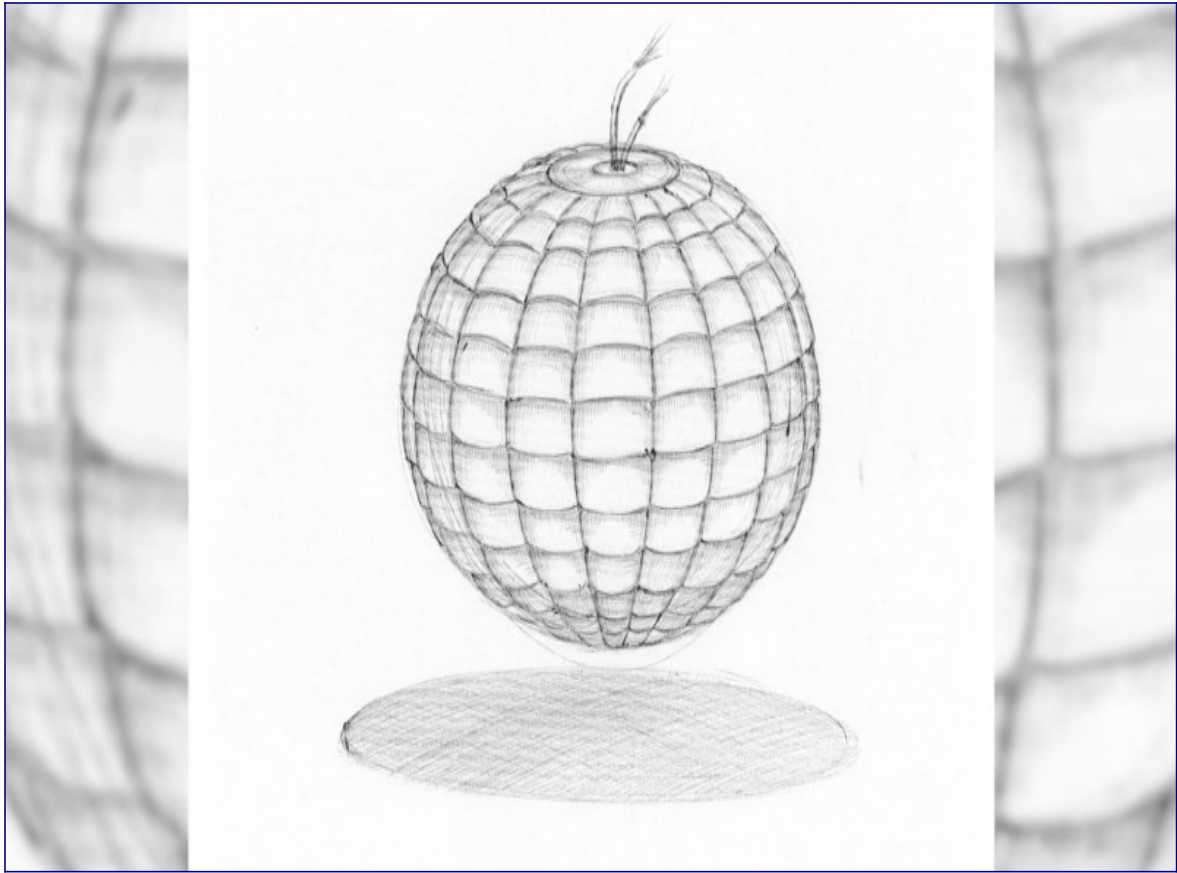

Now, he described this thing as sort of bobbing around, just a few inches above the surface of the ground, and every once in a while, it would begin to spin rapidly and sort of bobbing around.

And it would get a little bit higher off the ground, and then there'd be an electrical discharge between a couple of the wires coming out of this thing, and then it would sort of calm down and settle down again.

And so they were tasked with capturing this sphere. And the object would periodically make this little bit energetic dance, and so they had to kind of time it so they captured it at a moment where it wasn't too energized.

And they had one of these large, utility-yellow, aluminum carrying cases the military is notorious for using, with a piano hinge along one side and the turnbuckles on the other. You know, you bring it together and lock it up real tight.

And so when they walked up with this thing like this [**Mark** has the backs of his hands together and his hands spread out] to try and close around it, and the aluminum was apparently reflecting a magnetic field that was created by this object.

And so when they would try to approach it, it would just sort of wander away. It would be repelled by the aluminum.

So then what they came up with is they took the lid off of this thing by undoing the . . . sliding the piano hinge and disengaging the pins. They slid the lid underneath this thing. And then they brought the bottom half of the case down over the top of it, engaged the hinge, closed the turnbuckles, and then they let go of the case.

And the case went “poof” [turning his hand up straight indicating fast movement] and stood up on end like a gravestone. It was really spooky from what they said.

But they brought in – and this is really pretty fantastic – they brought in a CH53 Super Stallion with a very long – at least a 100' long – synthetic lanyard that they hooked this container on.



Apparently, it was so powerful in terms of the magnetic fields it was producing, they were worried that it was going to screw up the avionics on the helicopter, and they booked out of there.

There were Navy SEALs with pea coats, the nightwatchman cap. They had the M-16s with the under and over grenade launchers.

They had two Cobra helicopters, fully armed with the missiles and the whole nine yards, orbiting the site.

And they collected as much debris as they could. It was carried off to a vehicle that was on a roadway not too far away.

And then they put thermite grenades into what was left of the fuselage and burned it down to nothing.

David: I didn't even realize that anybody had ever gotten such a close description of what you call a Dart. How close does that look to what you've been saying you were getting picked up with at your house?

Corey: Well, we've recently had an image of the Dart produced.

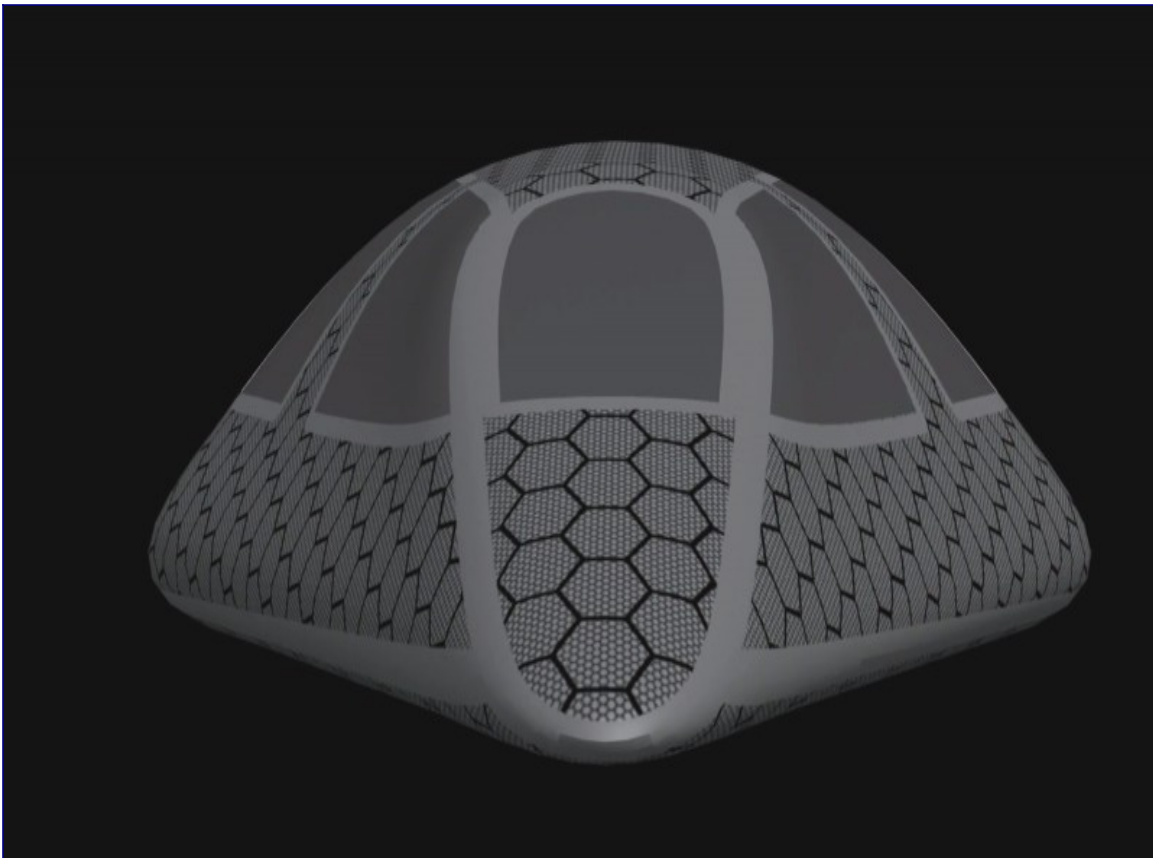

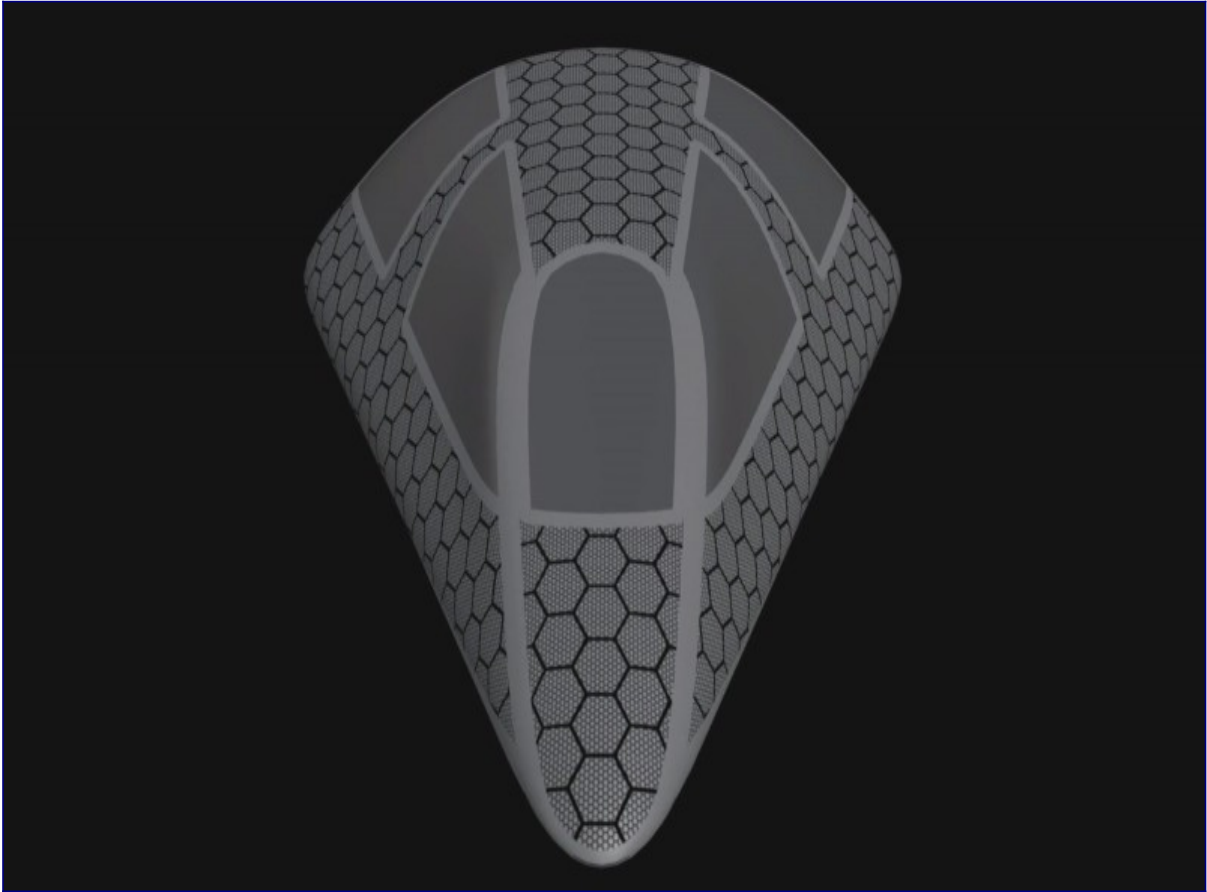
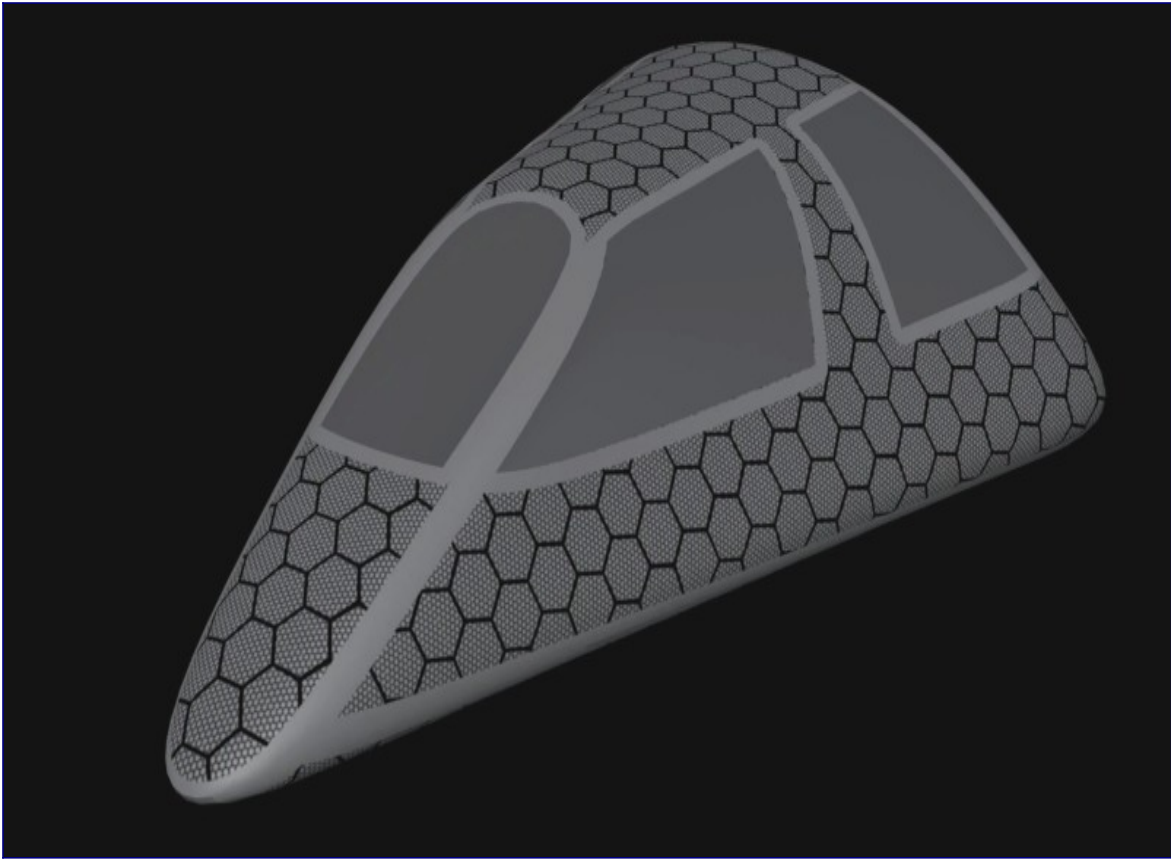

David: This is an astonishing connection. Just . . . They're so similar in how they look that I'm wondering if there are any differences, or if it's just that maybe your illustrator didn't quite have the ability to capture every nuance.

Corey: He didn't catch every nuance, but it is very close. This sounds like an early precursor to what we're calling the Dart now, . . .

David: Right.

Corey: . . . because it has a crew – the crew cabin – there are for two people. There are seats for two people.

And in the back, there are seats for three people.

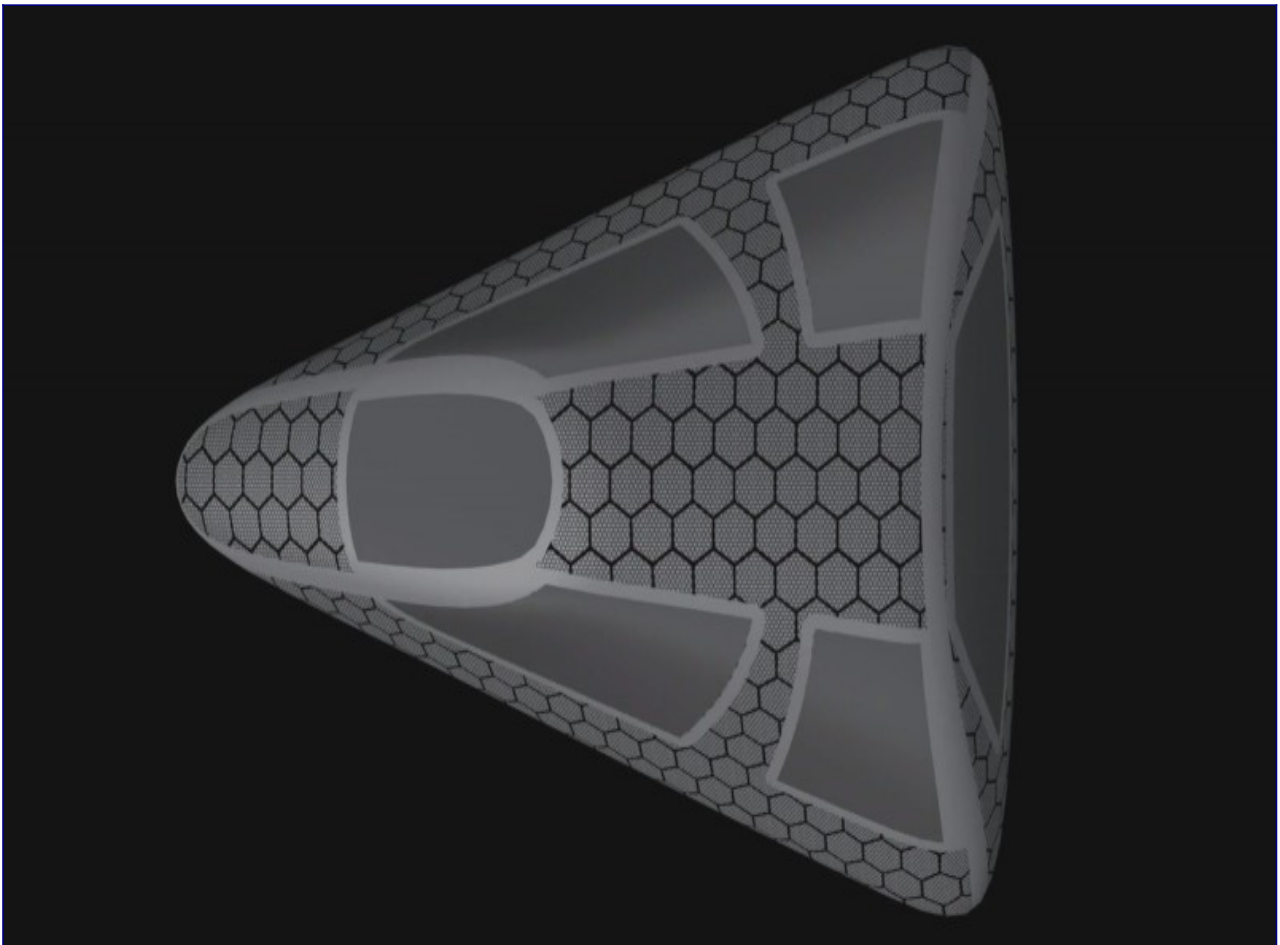

David: Right.

Corey: And no real . . .

David: In the Dart that you were on?

Corey: In the Dart that I was on.

David: Right.

Corey: And there were also these red or maroon like domes, three of them that hang from the bottom. And I had wondered why when I'd asked, what's – it was small – what propels the craft? What makes it work? And they would tell me that they have disco balls in them.

David: Ha, ha.

Corey: And I thought they were just screwing with me, but after seeing this orb that was floating around and how it was described, that could be very well what they were referring to.

David: Wow!

Corey: And that just hit me when I was watching that footage.

David: So even for you, you're getting surprised and learning some new things here.

Corey: Yes. And how he described from the front and the top, it looks like a triangle, and I had described it looks like a pyramid. It's built up like a pyramid from the side. That's exactly how it looks.

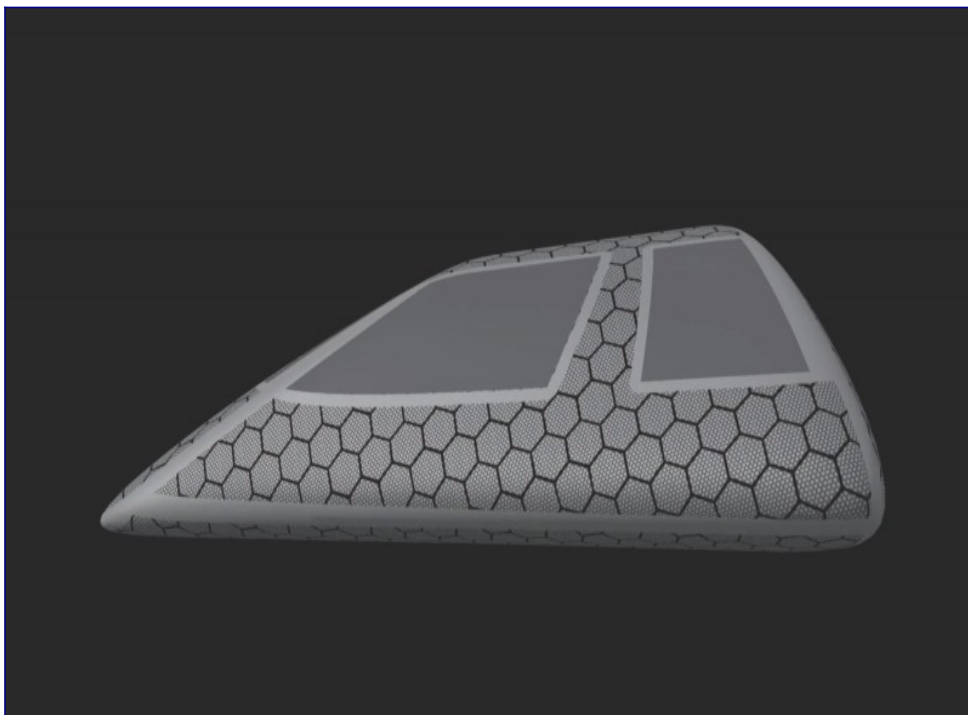

David: Do you think that the Dart will be one of the more commonly used craft in a post-disclosure world, that we will see a lot of these?

Corey: Different variations of it, yes.

David: One of the things I noticed that happened while we were watching this is that you had visible shock, or at least surprise, when he was describing Germany before the collapse of the Berlin Wall, and the idea that an American helicopter would have been able to go in there to do a crash retrieval operation.

So what was your reaction based on here?

Corey: I think that pretty much proves collaboration at the highest levels between the Soviet Union and the West during that time.

David: Ah!

Corey: Because there is . . . Anyone that lived during that time period would know that there is no way we'd be able to fly, especially air assets, into East Germany during that time period. They would be taken down quickly.

They had air defenses everywhere. It would have been . . . I think it would have been impossible to get air assets in there without collaboration between the United States and the Soviet Union up on the top level, where the Secret Space Program is being discussed.

David: One of my original insiders described having to transport 26 boxes of highly sensitive documents for a friend of his who was a high level Mason. And they had to do it very quickly in one night because there was a security breach.

And as a gratuity for risking his life to do this, he was able to open one of the boxes. And what he said, among several fascinating things that I've talked about before, is that he saw a document that was from the United States that apparently was given to every country in the world.

And they were told, "If a UFO crashes in your country, let us handle it because biological material could come out, radioactivity could come out, all these kind of things."

Do you think that that document is, in fact, true? And do you think that this is something that the U.S. generally handles wherever it happens?

Corey: The U.S. handles it, but the Soviets also have a great response group. I believe we called it . . . At least in the Army, it was called Pounce, Operation Pounce. For any foreign materials that would fall to Earth, they would go and recover them.

So the Americans would go in and recover materials in foreign countries. And usually the foreign countries would let us know, not just because they were scared and took our word for it, but there had been incidents, such as in Mexico. In the Zone of Silence, there was a UFO that crashed and they sent in American Pounce teams in full NBC gear to recover the craft. And when they did, there were, I believe, Mexican military that had died from exposure to the technology.

David: Now, you mentioned one of the five factions of the space program was the Global Galactic League of Nations. Do you think that the world leaders who are essentially told at gunpoint to give up these very valuable artifacts crashing in their country, that them being taken up to some kind of space base, is like a gratuity to keep them quiet, keep them happy, like they're inside something?

Corey: Yes, that's why that particular program was set up was to give other countries that know about the space program a seat at the table and also a way to keep them quiet about it, keep them from announcing it.

David: All right. Well, that's all the time we have for in this episode. It's absolutely fascinating stuff. Every hair on my arms was standing up when I saw that image of the Dart pop in front of me just now.

And **Corey**, you just nodded your head.

Corey: Yeah.

David: So it's really astonishing to work on this for so many years and to see completely isolated sources give you almost exactly the same stuff. That's where real disclosure starts to happen.

And it only happens right here on "[Cosmic Disclosure](#)", bringing you the tip of the spear for Full Disclosure. Thanks for watching, and we'll see you next time.

Cosmic Disclosure: Analyzing Joseph Skipper's Photo Archive

Season 7, Episode 23

David Wilcock: All right. Welcome back to another episode of “[Cosmic Disclosure](#)”. I'm your host, **David Wilcock**. I'm here with **Corey**, and we're going to do some show and tell for you.

We have pictures of anomalous formations, picked out by the Internet sleuth, Joseph P. Skipper. And whether it is actually real or not, it certainly opens our imagination and it lends itself to discussion about what may or may not really be there.

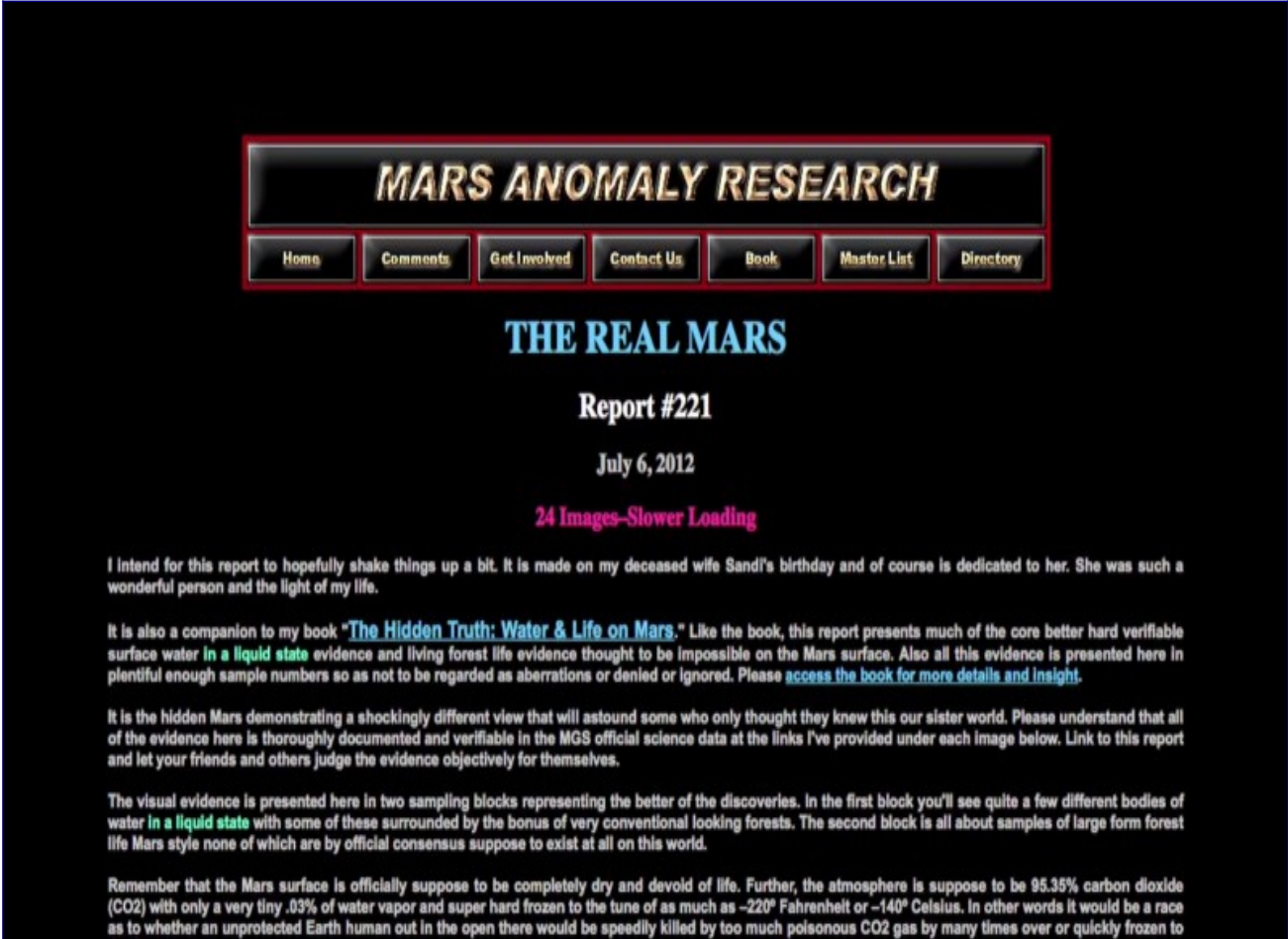

MARS ANOMALY RESEARCH

Home Comments Get Involved Contact Us Book Master List Directory

THE REAL MARS

Report #221

July 6, 2012

[24 Images—Slower Loading](#)

I intend for this report to hopefully shake things up a bit. It is made on my deceased wife Sandi's birthday and of course is dedicated to her. She was such a wonderful person and the light of my life.

It is also a companion to my book ["The Hidden Truth: Water & Life on Mars."](#) Like the book, this report presents much of the core better hard verifiable surface water **in a liquid state** evidence and living forest life evidence thought to be impossible on the Mars surface. Also all this evidence is presented here in plentiful enough sample numbers so as not to be regarded as aberrations or denied or ignored. Please [access the book for more details and insight](#).

It is the hidden Mars demonstrating a shockingly different view that will astound some who only thought they knew this our sister world. Please understand that all of the evidence here is thoroughly documented and verifiable in the MGS official science data at the links I've provided under each image below. Link to this report and let your friends and others judge the evidence objectively for themselves.

The visual evidence is presented here in two sampling blocks representing the better of the discoveries. In the first block you'll see quite a few different bodies of water **in a liquid state** with some of these surrounded by the bonus of very conventional looking forests. The second block is all about samples of large form forest life Mars style none of which are by official consensus suppose to exist at all on this world.

Remember that the Mars surface is officially suppose to be completely dry and devoid of life. Further, the atmosphere is suppose to be 95.35% carbon dioxide (CO2) with only a very tiny .03% of water vapor and super hard frozen to the tune of as much as -220° Fahrenheit or -140° Celsius. In other words it would be a race as to whether an unprotected Earth human out in the open there would be speedily killed by too much poisonous CO2 gas by many times over or quickly frozen to

Here to discuss this with me is **Corey Goode**. So, **Corey**, welcome to the show.

Corey Goode: Thank you.

David: So the first image that we have here is of a rock, which, when we zoom in on it up close, they look sort of like a capybara or a prairie dog.

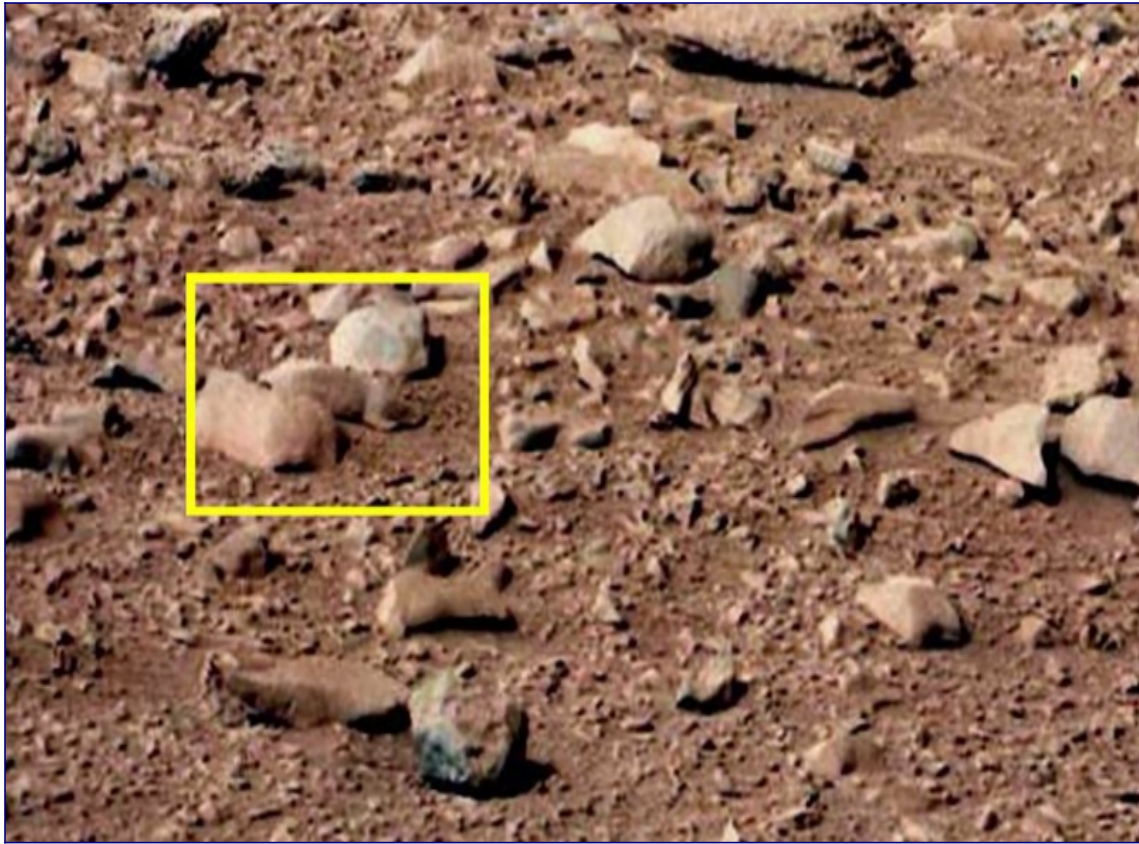

Whether what we're seeing here is authentically a rodent or not, is there any potential truth behind this based on your knowledge, **Corey**?

Corey: Well, I think I've reported before that in the smart glass pads, I had read that when the Germans were building these different bases on the moon and on Mars, in their larger craft, they were bringing a lot of food and supplies.

And within those food and supplies, they had different rodents like rats and spiders and cockroaches, things like that, that hitched a ride with them.

Now, after some time, of course, they are trying to get them out of the base that they're staying at, so they chase them out into the environment of Mars where they think they'll perish.

But some of the information stated that the rats that had been out in the environment for a while began to mutate, and they were larger, and they began to look a little bit differently.

And also there were remarks about different insects that had gotten larger, and they think it was because of the radiation.

David: Lack of atmosphere causing more radiation from the Sun.

Corey: Right.

David: If NASA has recently announced that there is, in fact, liquid water, standing pools of water on the surface of Mars today, then wouldn't it stand to reason that they would be able to survive?

Corey: Well, yes. I mean, they could be eating the bugs that escaped from the same bases.

David: Right.

Corey: So we may have created a little environment, or they may have taken over the environment of other indigenous life that was on Mars.

David: Okay. So, now what we're going to see is an image that was apparently sent to Joseph P. Skipper by someone from the European Space Agency, or ESA, and it particularly deals with the Hale Crater on Mars.

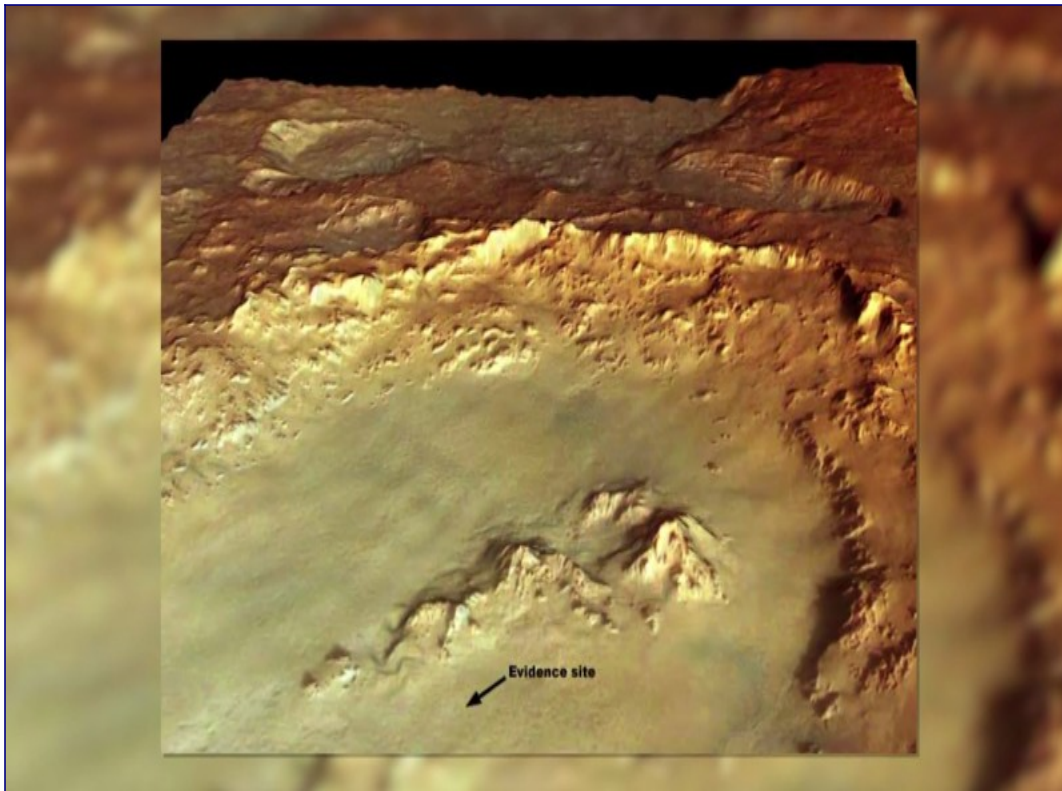

And what you're seeing in this image where it says "Evidence site", is an area where, as we get closer and closer, we start to see some very strange grid work.

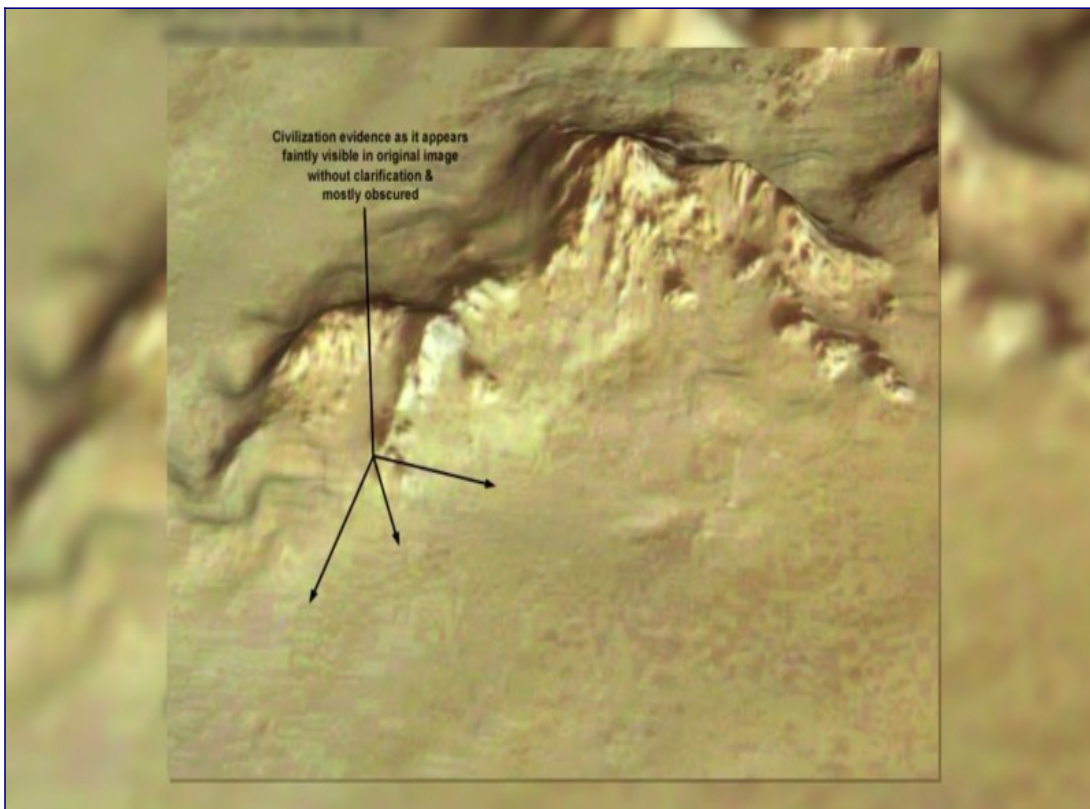

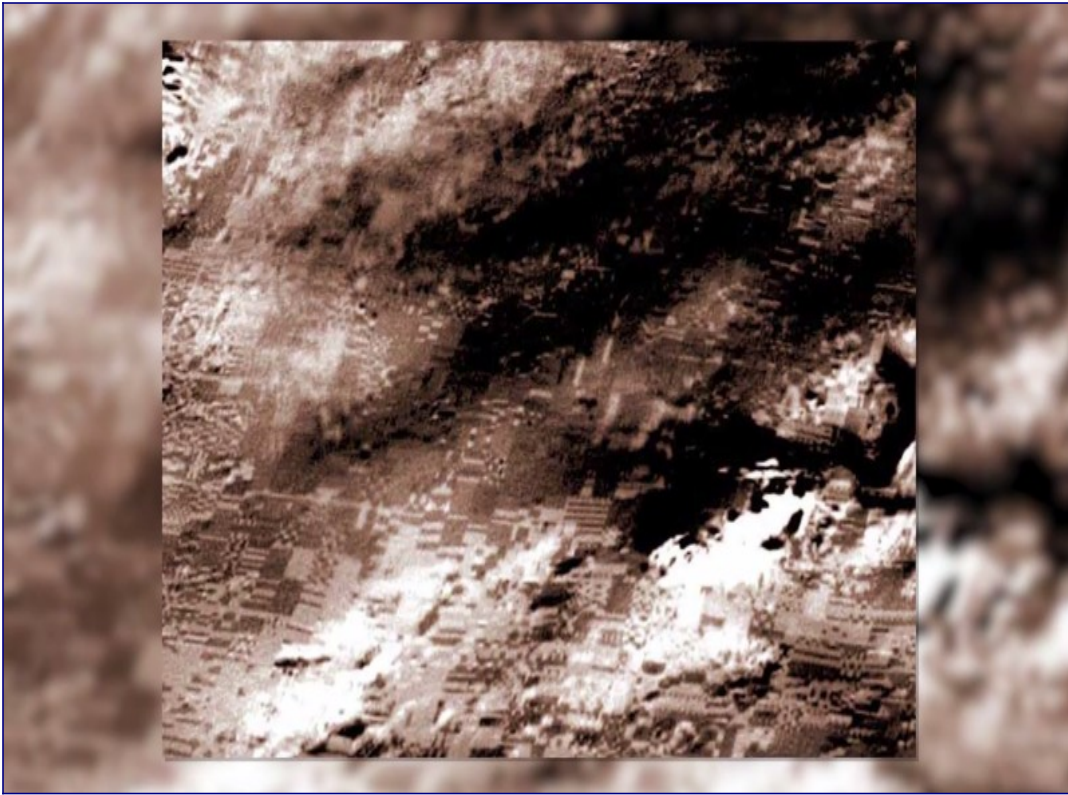

Now, at this point, we're really starting to see some bizarre stuff.

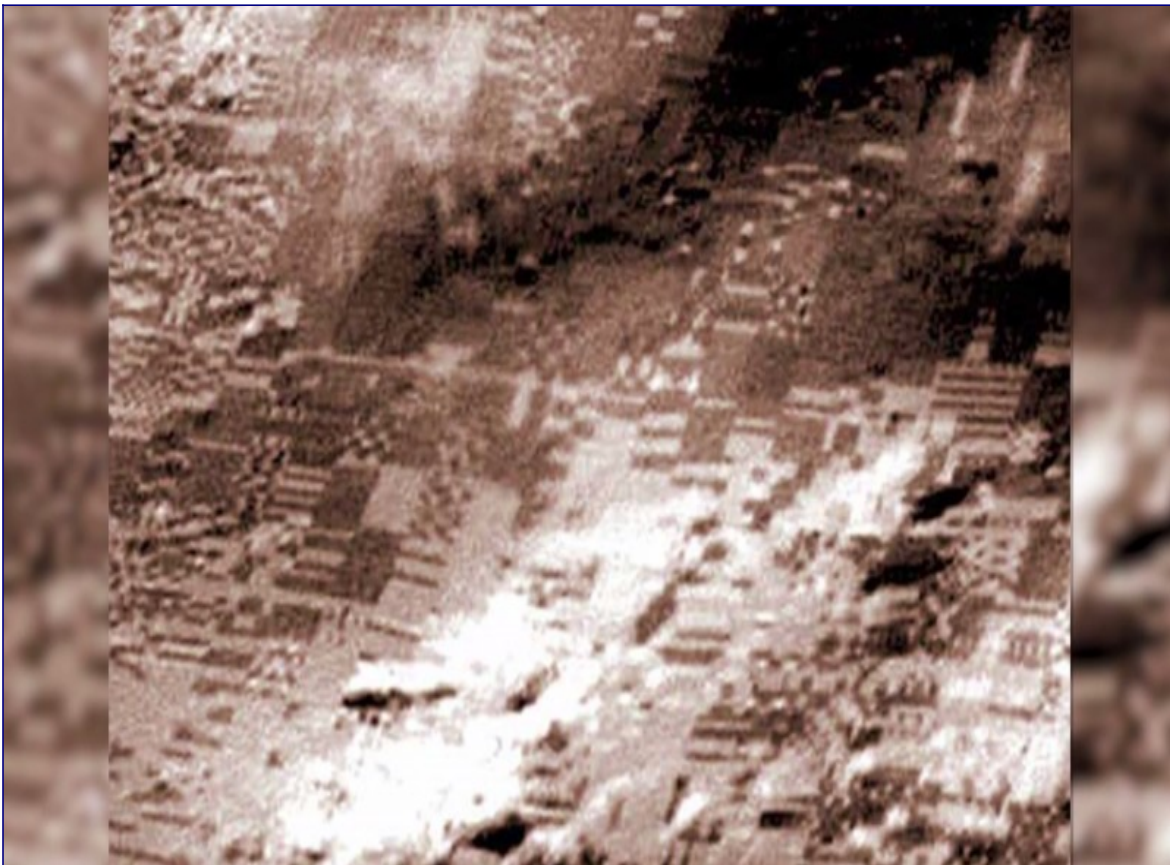

Corey, what do you think we're looking at here?

Corey: You know, I'm unsure. When I've been brought to different bases or different locations on Mars, we usually had a steep approach to prevent you from seeing certain things.

David: Uh.

Corey: And when you would see them, it was difficult to know exactly where they were when you saw them. So this could very well be some artifacts that were captured that I haven't seen before.

David: It's very odd because there do appear to be patterns of, in some cases, groups of straight lines. There does appear to be an architectural organization to this.

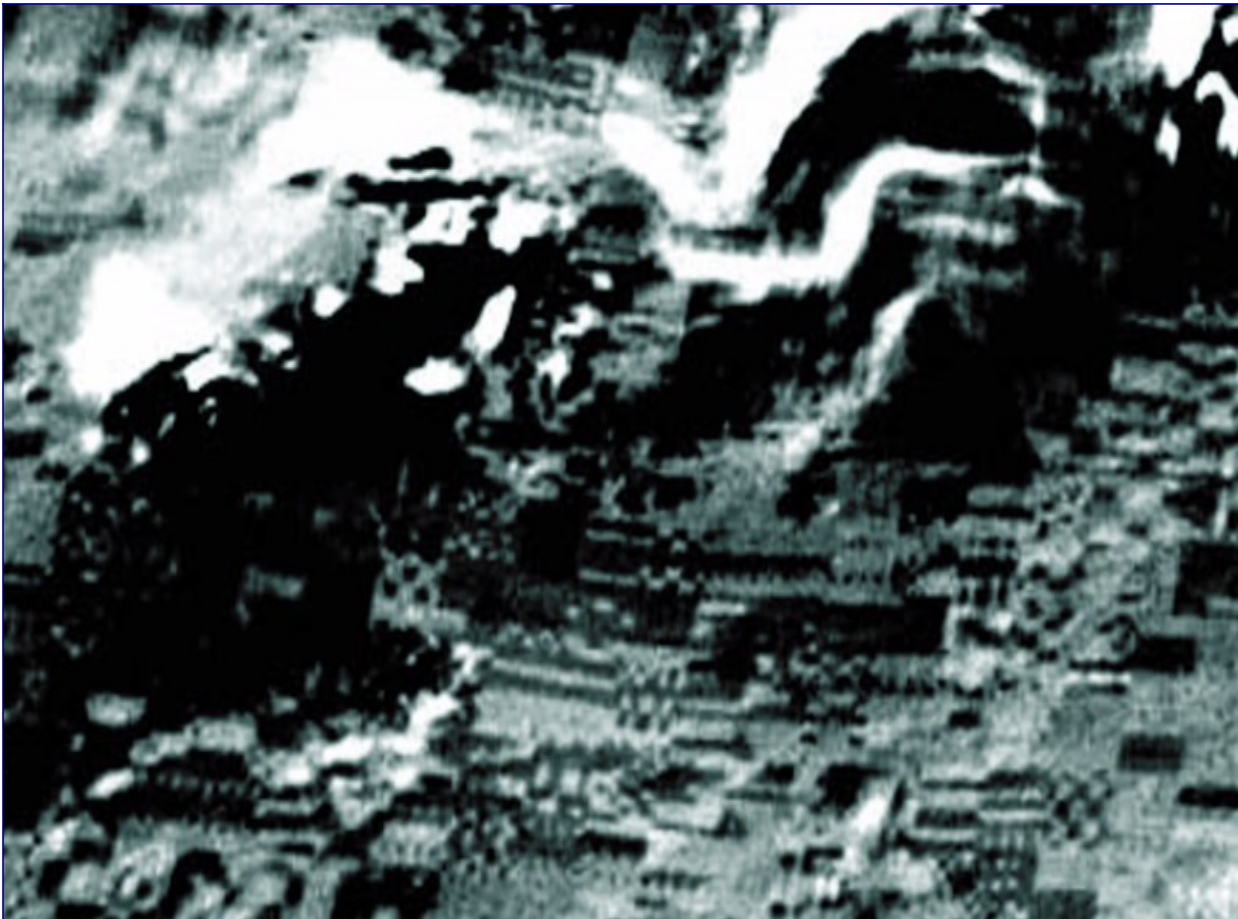

Another thing, **Corey,** that's very bizarre about this is that some of it looks sharp, whereas other sections, as we can see in this image, have a blur effect around them, almost as if someone had deliberately not wanted us to see certain parts of this image.

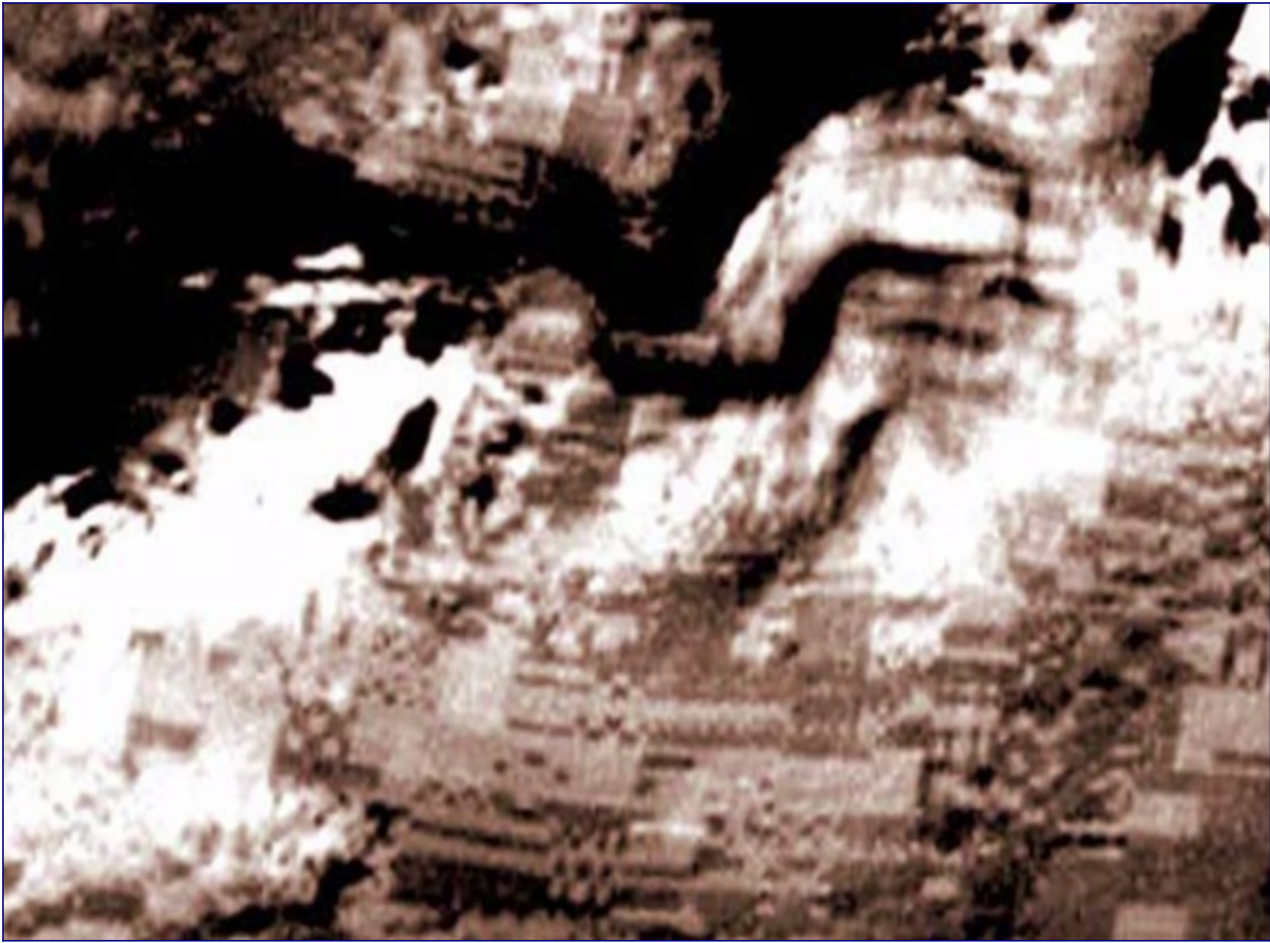

So what do you think is going on there?

Corey: Well, if you spent a lot of time looking at the Google Earth feature for Mars, you'll see some areas where they've stitched together different groups of photographs and will cause some things. But when you find areas where everything else around it is clear and there are spherical or elongated type of pixilation areas, that is usually an area for you to try to concentrate on and look around to see if you can find anything else smaller, because even on the Internet, if someone finds something interesting today on Google Earth for the Moon or Mars, usually within weeks, if you go back, it's been pixilated.

David: Really?

Corey: Yeah.

David: And people have documented this?

Corey: Yes, very recently. And interestingly enough, even with higher resolution cameras, when you're above Mars looking at what used to be structures, the ruins, much of them are covered in a thick mud –

like they were covered by a thick mud, and then after most of the moisture was pulled off out of the atmosphere, the mud kind of solidified.

David: Sure.

Corey: And mostly what you see are areas of structures, or corners of structures, sticking up out of this mud, or pieces of structures strewn out on top of and under this dried out mud.

David: Are you aware of there being any bases in which series of long corridor-like halls would be built, where they're all parallel to each other?

Corey: Yes, I've seen that very often, but this could also be the remnants of what once was a settlement on the planet.

A lot of these settlements look like almost melted adobe, like they were built out of adobe bricks, or just a massive adobe structure, and all of the water that poured across it in some sort of a catastrophe, just seemed to melt it.

Some of them look somewhat melted, but they looked like they were made out of a type of adobe.

David: So, **Corey**, if there is something in this particular Hale Crater, why do you think the crater might be a desirable location for a settlement to be built?

Corey: For a couple of reasons. They would build inside craters because craters would offer a small amount of protection from wind storms – wind is a big problem on Mars – and it also, depending on how the Sun is traveling through the sky, the craters will provide shielding from solar radiation.

David: Okay. So, could there also be something having to do with the scarcity of water, and that the crater might actually be a better location to harvest water?

Corey: There might be water underground. But one of the second reasons it's a good place is that under a lot of these craters, the impact, when the impact occurred, it has caused fissures underneath that can be exploited and dug out and widened to make underground bases that are more shielded from the environment.

David: All right, so this looks like a dendritic branching pattern of something that clearly seems to be above the surface of the terrain.



What do you believe we're looking at here?

Corey: Well, I think I've spoken in the past about these strange colonies of bushes that would grow that were very stickery, like briars . . .

David: Okay.

Corey: . . . and sharp pointy leaves that had purple and red in them that grew sort of in colonies. The roots or some of the vines would shoot into the ground and then come out, and then another plant would sprout and grow.

And they would radiate out from a center, original plant. That looks very similar to the growth pattern that these bushes would do. So this could be an aerial photo of it at a lower definition.

David: Is this similar to what you witnessed that they actually look like? In other words, did you see things that looked like this but were clearly three-dimensional, rounded shapes as you would fly over them?

Corey: They were round in the sense that when you looked at them, they radiated out into a circular pattern.

David: Oh.

Corey: But when you're closer to them, you see all of the . . . just different patterns of how the plants are growing through the ground and sprouting up.



David: **Corey,** it seems like we're seeing a much more densely packed area of these sorts of things. It's very, kind of fluffy, but it actually looks more like a forest.

Do you think it's possible that this is a more dense area of that type of foliage? Did you ever see it come together in a thick area like this?

Corey: In certain areas, it gets thicker, but they're usually more sparse. This is kind of . . . These are kind of like desert-looking plants.

David: Okay.

Corey: They're tunneling deep for water, or they'll be close to one of these pools that have built up in a crater, like a crater-type lake. And the standing water in it is full of sediment.



It would be like going to a lake in Oklahoma, if you've ever seen one of those, and the water looks almost red because of all the red sediment that is suspended in the water.

David: All right. We now have an image that is strange because we're looking at the bush type of phenomenon again, but it clearly seems that there's been some tampering with the image.



MGS MOC M09-02042 — Official view 200% — rotated 90° CW MAR Report 020 — 8th of 11 images



MGS MOC M09-02042 — Inverted view 200% — rotated 90° CW MAR Report 020 — 9th of 11 images

Corey, what we're seeing here looks like somebody played around with the brightness and contrast filters in Photoshop in some way. And if you did that, you could make shadows that clearly were three dimensional objects not look like shadows anymore.

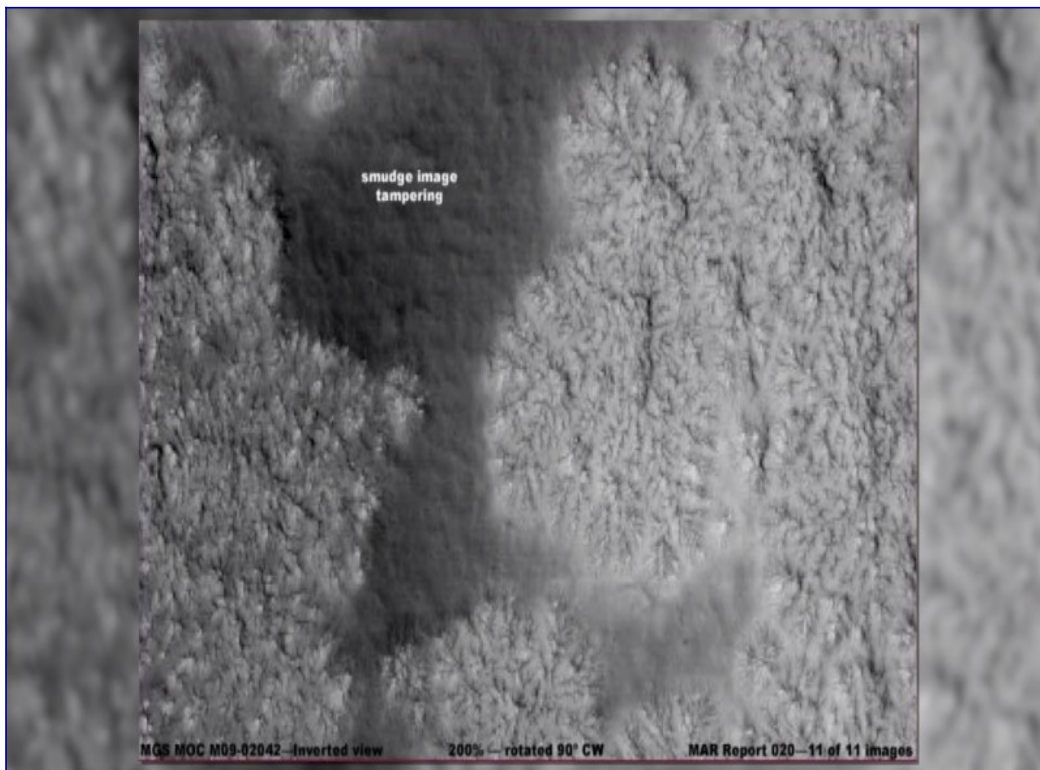
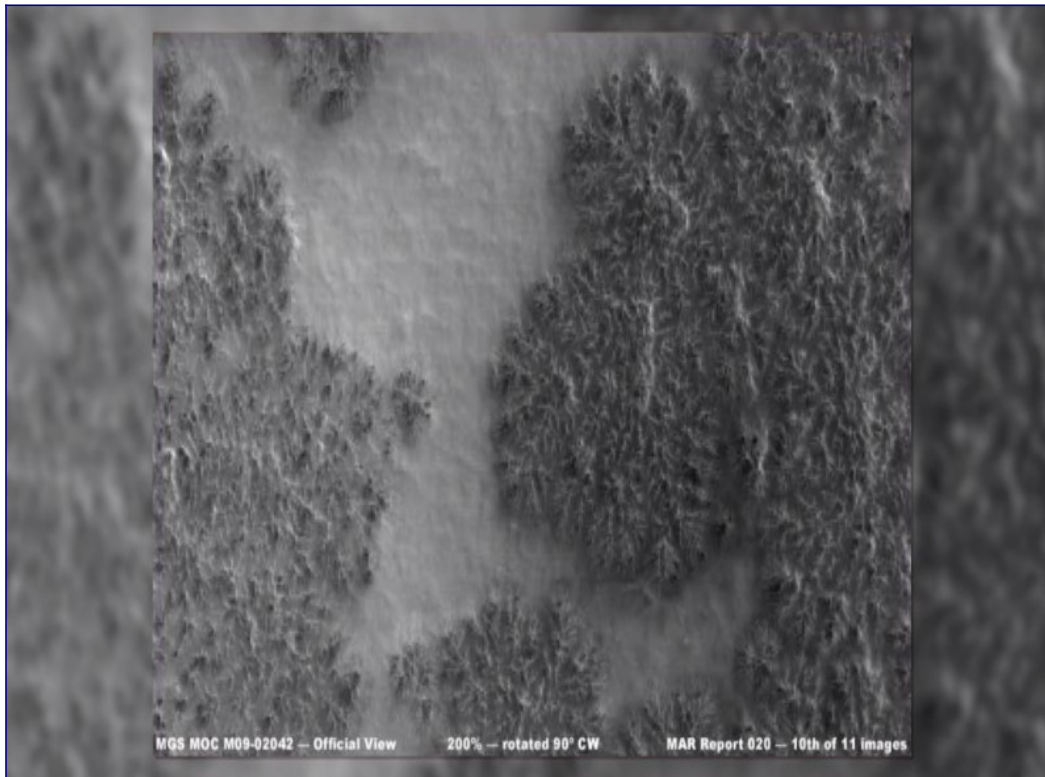

This clearly appears to be a tampered-with image. What do you think is going on here?

Corey: I agree. It looks like we're looking at something similar as the last image, some sort of radiating out pattern of biological growth that they somehow played with the image to make it look like just weird shadows and hills.

David: And this is something that NASA is going to do routinely if there's things there they don't want us to see.

Corey: Yes, and we've had whistleblowers come out and talk about NASA smudging images of the Moon, . . .

David: Right.

Corey: . . . so why wouldn't they do it on Mars?

David: Okay. Now, we have one of those images that, maybe it's just a rock, maybe it's something else.

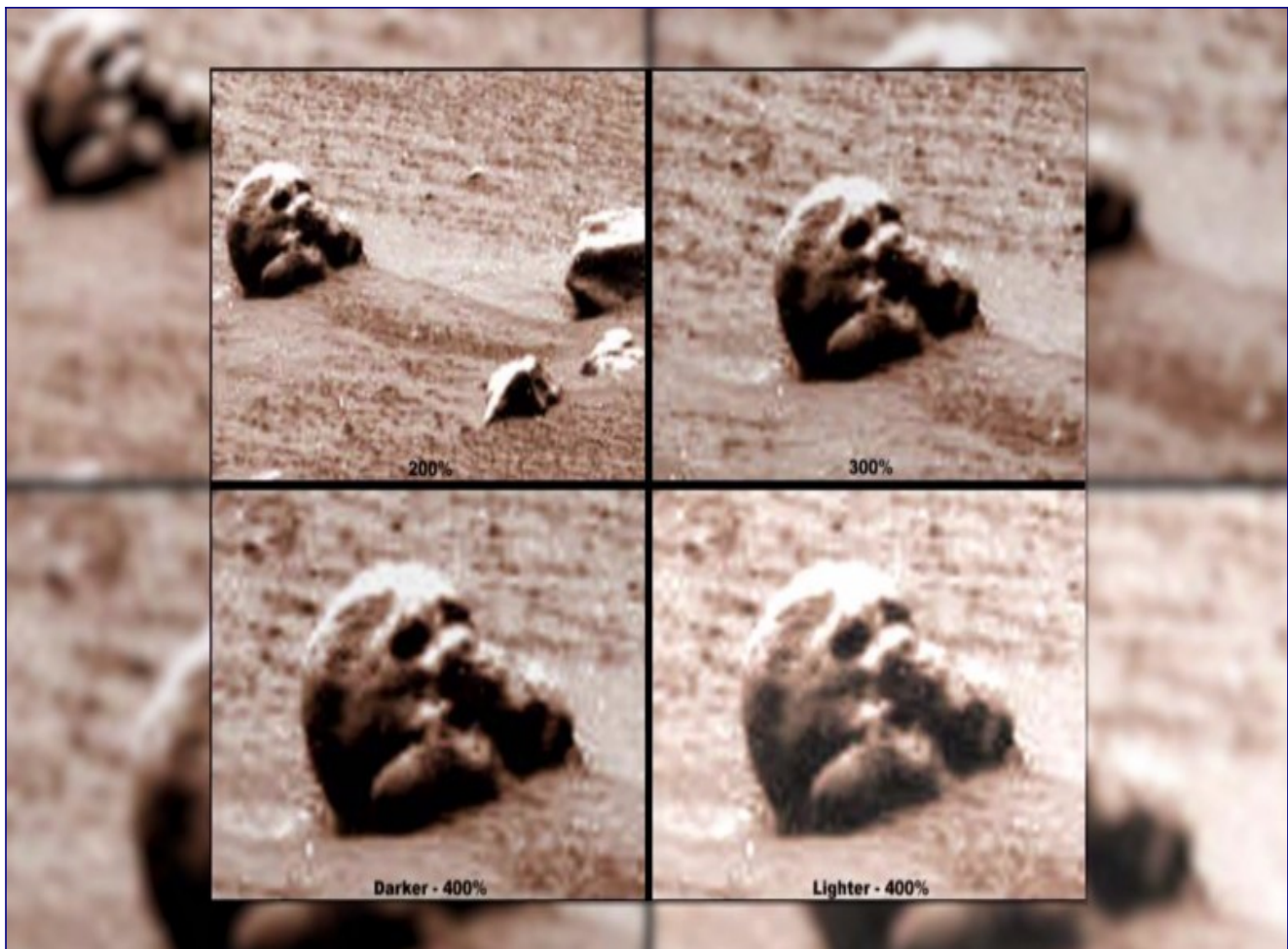

And there is a kind of a humanoid skull appearance to this particular formation.

To your knowledge, **Corey**, have there been actual skeletons that are on the surface of the ground after all this time and catastrophic activity on a planet like Mars?

If you do know where to go, can you find human remains that are visible on the surface?

Corey: They have found fossilized remains, and what I described earlier, this sludge that was once like a mud that had covered all of the artifacts, and then when it dried out, it solidified. So it's almost like a . . . It's a real porous kind of rock or dried mud. And they'll find some under that – some of the skeletons.

But a lot of what they found are . . . there were giant statues of different characters, and they found broken pieces of the shoulder here, a part of the head there. So what we could be seeing, and we're jumping to a conclusion, that it's a dead body or something like that.

It could have been some of the ancient structures and statues.

David: There was something that happened that came to my attention back in the early 2000s, where Rush Limbaugh, and it was on April Fool's Day, but he did something on his show called the Gore Report. And he talked about this Gore Report, and he basically announced that there was life on Mars, said that they'd had a totalitarian government, that there was a small central elite that was ruling over the people, and the people were very oppressed, whereas the elite were very wealthy.

Corey: Sounds familiar.

David: Yeah, it does. It's interesting. And he also said that bodies were found, but that they were like Pompeii.

Now, somebody sent me this link, and I publicized it on my website after he said it, and almost instantaneously, the show was completely scrubbed from Rush Limbaugh's website.

I don't know if Rush Limbaugh actually had been told anything that was true, but why do you think something like this broadcast would have suddenly disappeared from the website, and could there be any truth to what Limbaugh was saying during that broadcast?

Corey: Yeah, I mean it's very probable that there is truth to it. Whether he knew what he was saying was . . . that there was truth in it, or was just a big joke, I don't know.

But a lot of times, a lot of truth is delivered in jest.

David: Another interesting thing about this Gore Report – and it seems like he was talking about Al Gore, and the whole climate change thing was big at the time – was he said that he got this from classified briefings.

And when he starts it out, he said that he has contacts with people that most people would not be able to get to talk about this, but that because of his position as this famous radio show host, that he was able to get information that was unavailable to most people. So it was very curious that he spoke about this.

Is it possible that someone like Rush Limbaugh could be given classified information, even though there may be a risk of him talking about it on his program?



Corey: Of course. A lot of times information will be delivered to an individual or a group, and for plausible deniability, or a way to deliver the information without really getting in trouble, they will deliver it as a joke or put it out on April 1st.

David: Right. All right. Now, what we're looking at here, **Corey**, is so bizarre because we have Donna Hare.

See clearly testifies that NASA employees are hired to airbrush out anomalies. When we see this picture, it very much looks like somebody did a crappy job, phoned it in, to airbrush out some kind of tower.

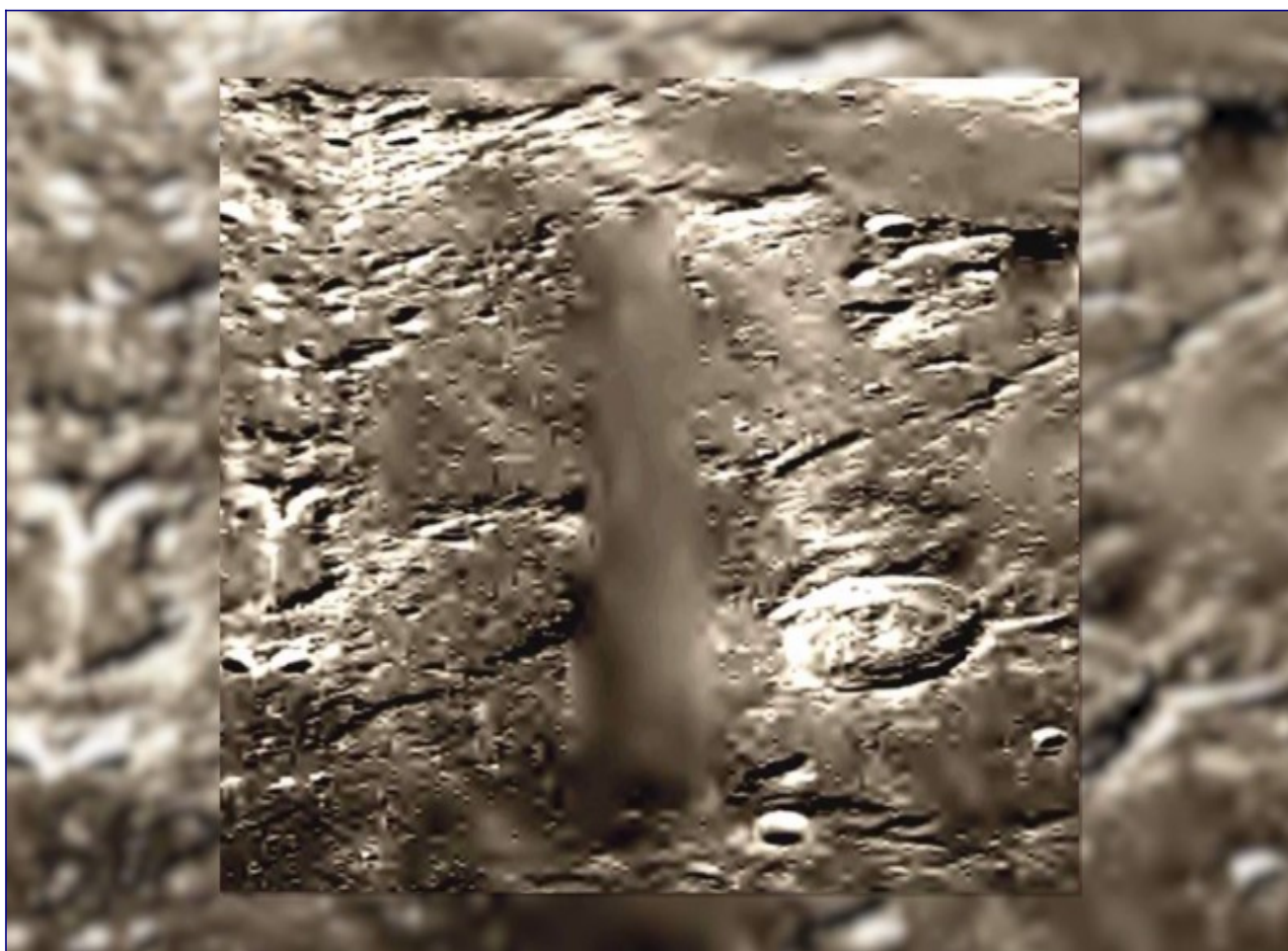

So are there, in fact, towers that would have the kind of slope angle and structure of what appears to be the blurred-out area in this image?

Corey: Yes, and I'm told that some are up to two miles.

David: Two miles tall.

Corey: Tall.

David: So now we're going to the Moon, and we're going to see some very interesting images here, that Joseph P. Skipper first brought to our attention, of strange anomalies that appear to be blurred out on the Moon's surface. Let's take a look.



Corey, what we're seeing here looks kind of like the same tower or a similar tower at the bottom. But then if you look carefully on the left, going up, there is actually a series of straight lines.

And these straight lines cut in about a quarter of the way over from the left toward the center of the image. They're all horizontal, and they definitely look like they don't belong.

What do you think there could be? Are there roads on the Moon's surface? Do they have vehicles that actually travel by land, or are they all like antigravity type or spacecraft?

Corey: I haven't seen a whole lot of road-looking anomalies, but I have seen what looks like tracks from a large excavation machine that didn't belong to us. They're pretty ancient.



David: All right. Now in this image, you're going to see some very interesting stuff. **Corey,** it looks like we have a blurry image that totally barges in, intrudes over two otherwise normal-looking craters, and it is sort of a lighter color on the left and a darker color on the right.

Do you have a feeling that there could be, in fact, structures on the Moon's surface that would have that level of almost blackness to them, if you look at them? Because whatever was blurred out here, looks like it has a very dark color.

Corey: I don't remember seeing anything black, but there are certain structures that were obviously damaged in some sort of a conflict.

Now, that could be carbon build-up from some sort of a weapon. I don't think there are going to be

many open fires on the Moon – not a whole lot of oxygen to burn. But I can't really identify anything that I remember seeing that was really black.

David: This last image that we have is certainly extremely curious.

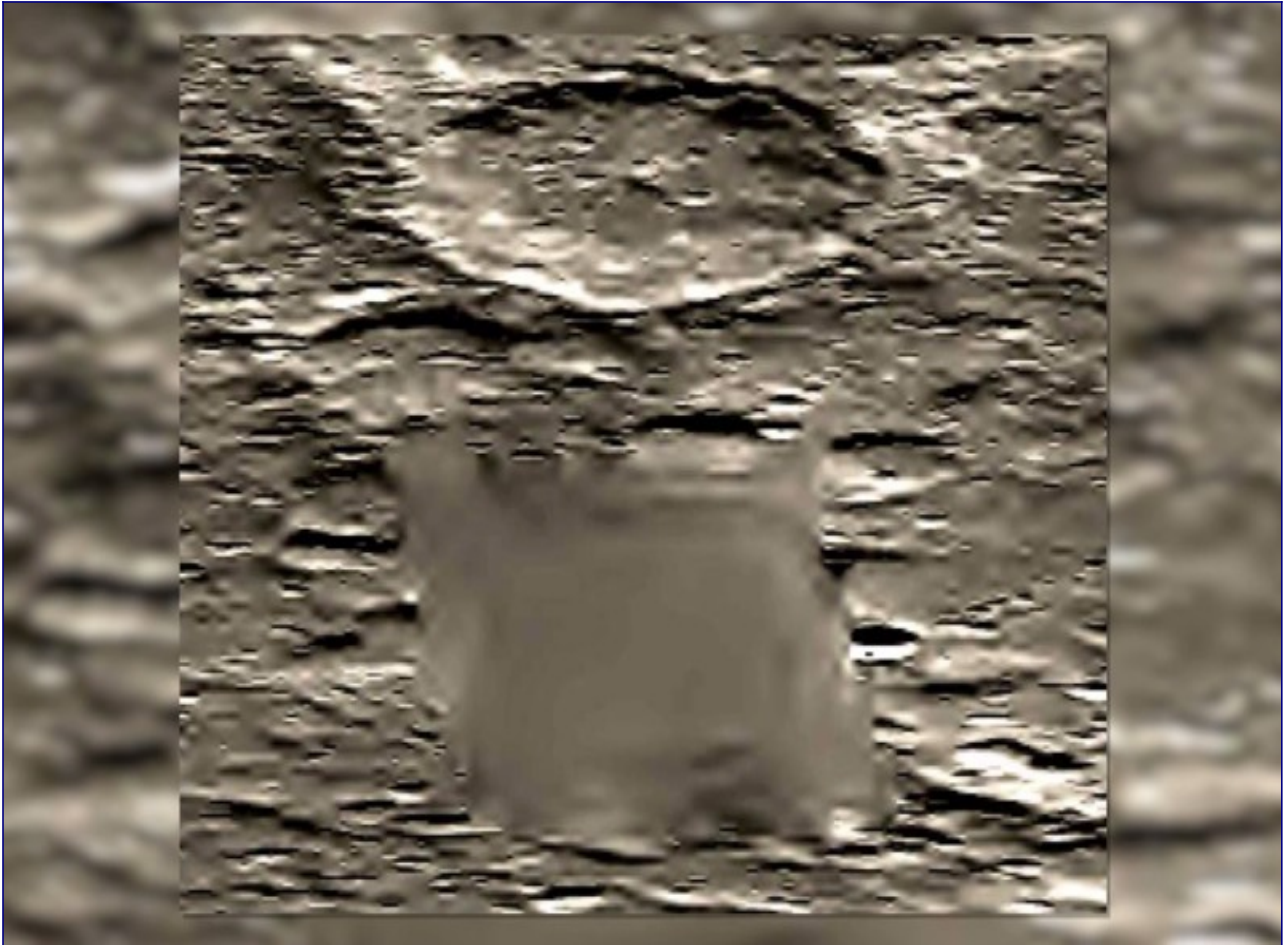

Now **Corey**, I know what I think I'm seeing here. It looks very obvious to me. What are your feelings when you look at this?

Corey: It looks like a dome to me, and not all of the domes are completely spherical. The spherical domes that are there are broken and shattered, many of them.

This one looks like some of the domes that I saw that were somewhat trapezoid-shaped. If you get, I guess, gumdrops or the candy you used to get when you were a kid that were sort of the trapezoid shape.

David: Yeah.

Corey: And that's the way they looked three-dimensionally as well.

David: All right. Now we're going to be going to some shots that are taken on Earth. These are Google Earth anomalies, again pointed out by Joseph P. Skipper, that suggest very strongly some anomalous structures on the floors of the sea here on Earth.

Corey, to start this off, there have been rumors about an extraterrestrial or human-ET joint base off the coast of Los Angeles, right near where I am around Malibu.

So first of all, before we get into these images, what is your statement that you could make on these rumors of some sort of anomalous base out at sea by Malibu?

Corey: The information I had was that it is an actual entrance to this, I guess, cave or fissure system that runs under the ocean all the way up under Nevada, the northwest, and then connects to other, I guess we'll call them fissures in the Earth, that go all the way down to Antarctica.

David: That far?

Corey: Yeah. Some of them . . . They didn't naturally make it all the way down to Antarctica, but this Ancient Builder Race had gone in there and tunneled out areas between rifts to create these large archways that . . .

David: You had commissioned art for us at one point.

Corey: Yes, and we have large electromagnetic submarines that travel up and down this rift system through those large arches.

David: So those arches, just like it shows in the illustration, they are going to look pretty sharp inside – almost like they're laser-carved. Is that true?

Corey: Yeah, except for the pieces that have kind of broken off and floated down to the bottom. You see that it looks pretty ancient.

David: Why do you think it had to be so large, because in your image here, the submarine looks completely tiny compared to the size of this dome.



Corey: And the submarine is actually quite large. They carry shipping containers. They're the size of the ships that carry these shipping containers.

And they travel underground electromagnetically. But I have no idea why these arches need to be so large, unless what they had traveling through them were much larger than what we have.

Or there were a bunch of them traveling through at the same time.



David: So what we're seeing here is a detailed view now near Islas San Benito, which . . . What we're looking at, **Corey**, seems like a very bizarre, non-natural formation.

Corey: Yeah. I mean it looks kind of like that glass tube on Mars with the ridges on it.



I think some people, they call it the worm.

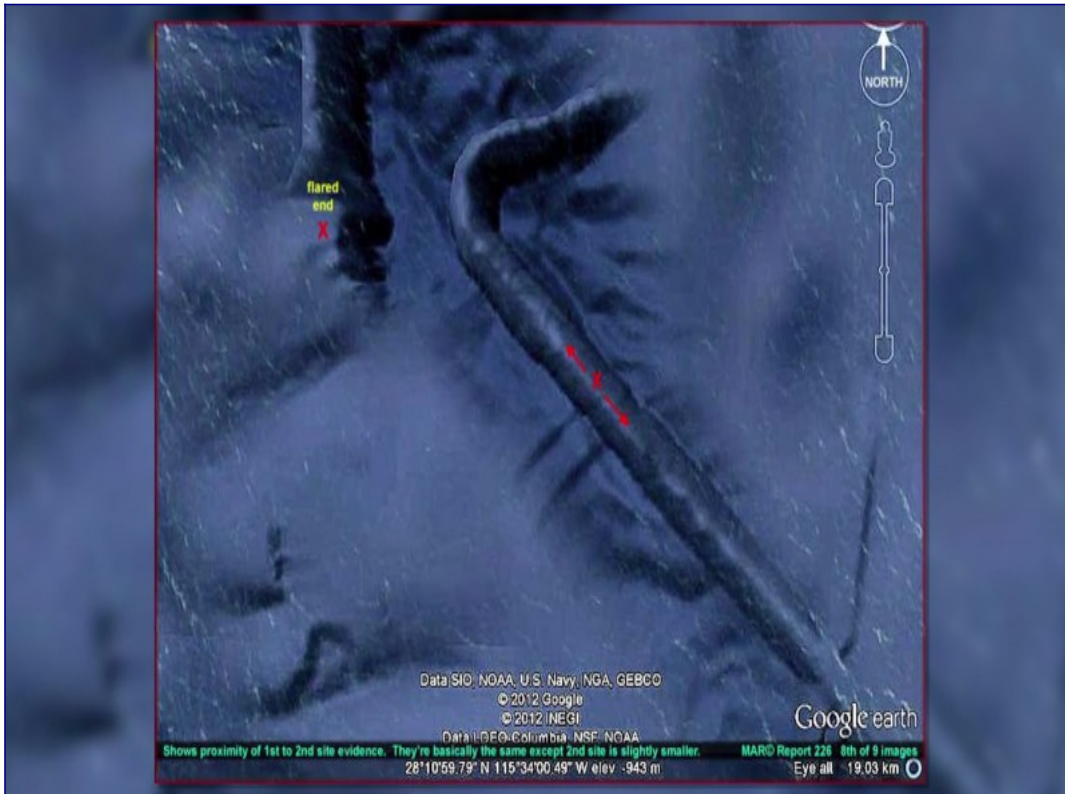

David: Now I'm also noticing here that it makes a kind of a gentle, not a sharp turn, the width doesn't change, and then it has a long, almost exactly arrow-straight pattern.

What do you think we're actually looking at here?

Corey: You're probably familiar with these deep boring machines that use nuclear power to bore through the hardest rock.

And it melts the rock and turns it into a glass that goes along the edges, and it kind of self-seals.

David: Right. And there's that infamous image of the big boring machine that says, "US Air Force", and it's white. It's got all these guys standing in front of it.



And now more recently, images have been publicly shown of borers that are much bigger than that, and they actually can go through and do something like a total underground subway system.



And these are publicly acknowledged. They've done it in Norway and various places like this.

Corey: And they vitrify the rock.

David: Right.

Corey: Well, you may have heard reports, or may not, about when they've been boring through long areas of rock, they've come into open areas, and they will back out and send out a little robot to take a look.

And sometimes they have cut into the exact same structure, a tunnel, that was created very similarly, but they are massive in size – much, much larger in circumference than the ones that we're digging.

And at times, nonterrestrials have appeared at that point where we have, I guess, egressed into their territory and told us to leave. Then we'll back out and then take another way around digging.

David: In some much older episodes, you mentioned that some of the abandoned cities are very deep down below the surface of the Earth.

Corey: Yes.

David: And they haven't even really been explored that much. I'm curious if anyone in the past might have used boring machines to bore their way down to some of those cities deep below to make a clear path that allows them to get in there.

Corey: Most likely what had occurred was that they were in the middle of boring out or excavating a new area to run their underground trams, and they ran into one of these things accidentally.

Now, they're able to do this weird remote imaging to where they can see these pockets deep in the ground, but they can't tell that much about them until they get there.

David: Ah.

Corey: If they're inhabited, that could be a bad situation if they pushed through. If they're uninhabited, they just can't tell.

And as I stated before, they came into . . . they pushed through into some massive areas that were real square, cut into the rock, that used to be large areas for, I guess, a civilization to maybe hide during a cataclysm.

David: Since we're on the subject, Ancient Aliens is always talking about Cappadocia, Turkey, these tunnels that have been dug several layers deep – I think nine layers deep around Turkey.

What do you think Cappadocia is, just so we get you on record for that?

Corey: To me, from a, I guess, a military perspective, it looks like a place that you're sequestering people to hide them from an invasion or a cataclysm.

David: It seems really odd that anybody would have taken the time to dig that out with conventional technology. It would have taken an eternity.



Kaymakli Underground City, Cappadocia



So do you think there was some unconventional technology used for Cappadocia?

Corey: Even if it wasn't a physical technology, that mathematical technology used to be able to do all of that is more advanced than what we believe they had back then.

David: All right. Now, we're looking at a couple of images – we're going to do them side by side here – of that same tunnel system, but now we're getting in closer on it. And you can see that, in fact, it is very stable, very nice and straight.



There's a mouth at the front that we're looking at here. So that's a pretty large tube.

Are there tubes built by our Secret Space Program on Earth that would need to be that wide, and why would they make them that big?

Corey: I have not heard of our capability to make one single tunnel that large. The only thing I could see that we could do is take one of our smaller boring machines and thread the needles a bunch of times until you get that circumference.

David: Do you think there could be an extraterrestrial group that might be doing this for their own reasons with their own technology?

Corey: That's most likely. The nonterrestrial tunnels were extremely large.

David: All right. Lastly, we're going to go over to the Mariana Trench.

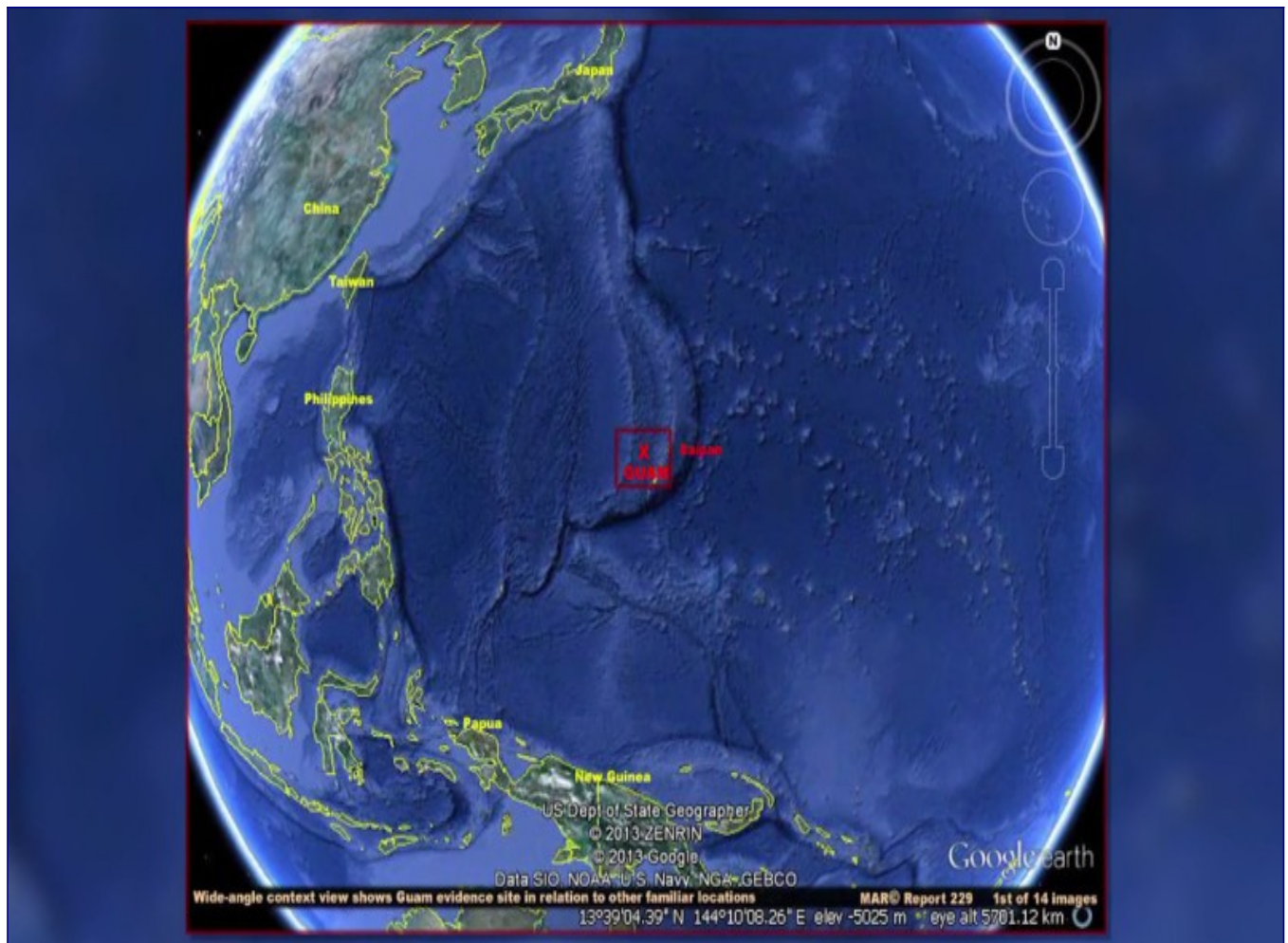

So first we're looking at it here from the wide view, and now we're going to zoom in more.

You can see there that Guam and Saipan are nearby this area that we're looking at. There's come crescent type of formations in the oceanic crust.

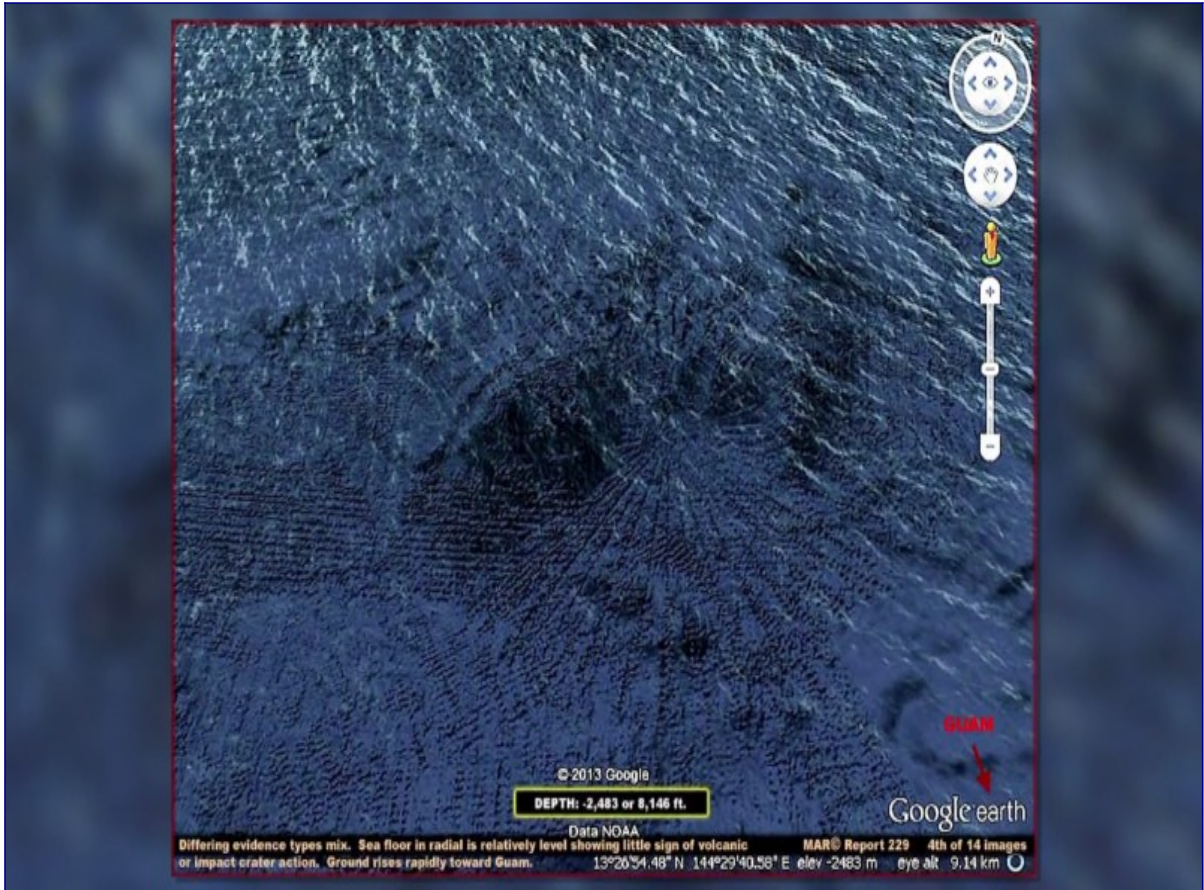
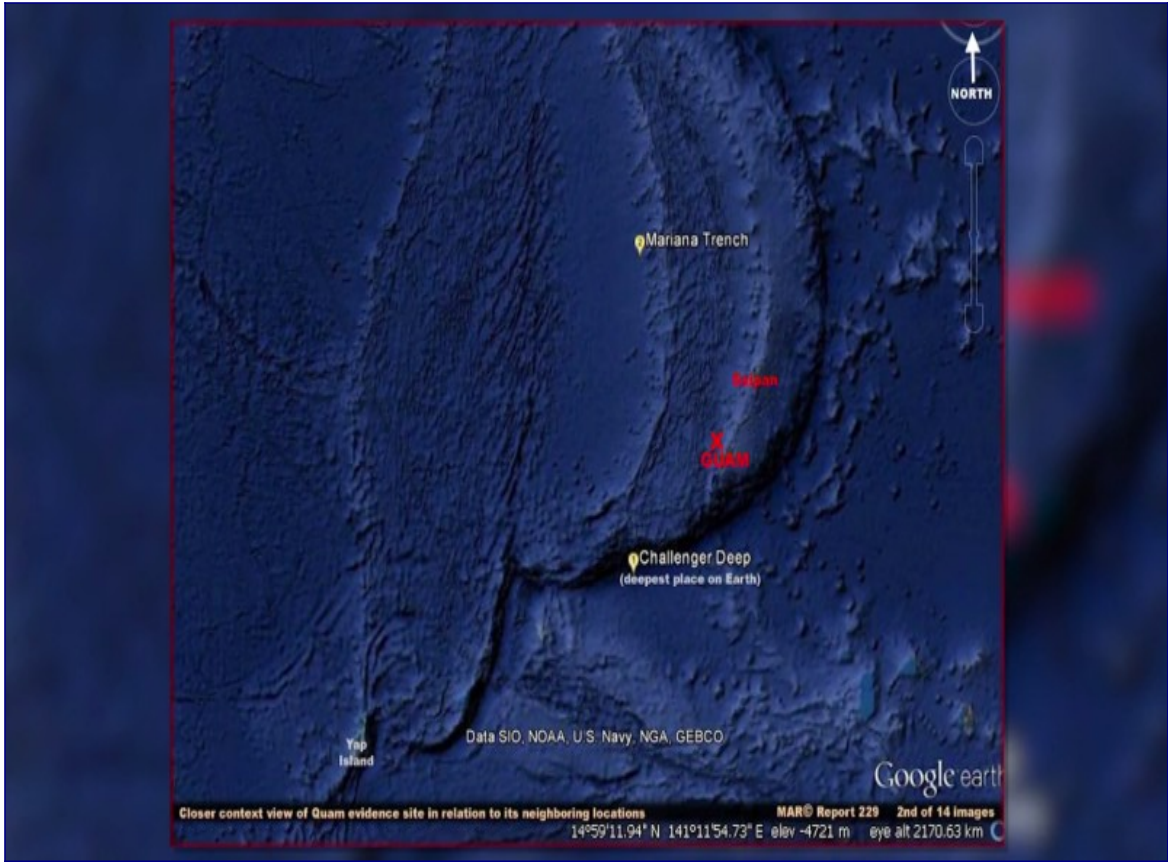

Now, what we're seeing here, **Corey**, is strange because at first, someone might think that this radial pattern that we're looking at is only some kind of imaging artifact, . . .



. . . but as we zoom in on it more, we see a series of radiating straight lines that absolutely appear to be a set or regular striations in the surface of the oceanic seabed.

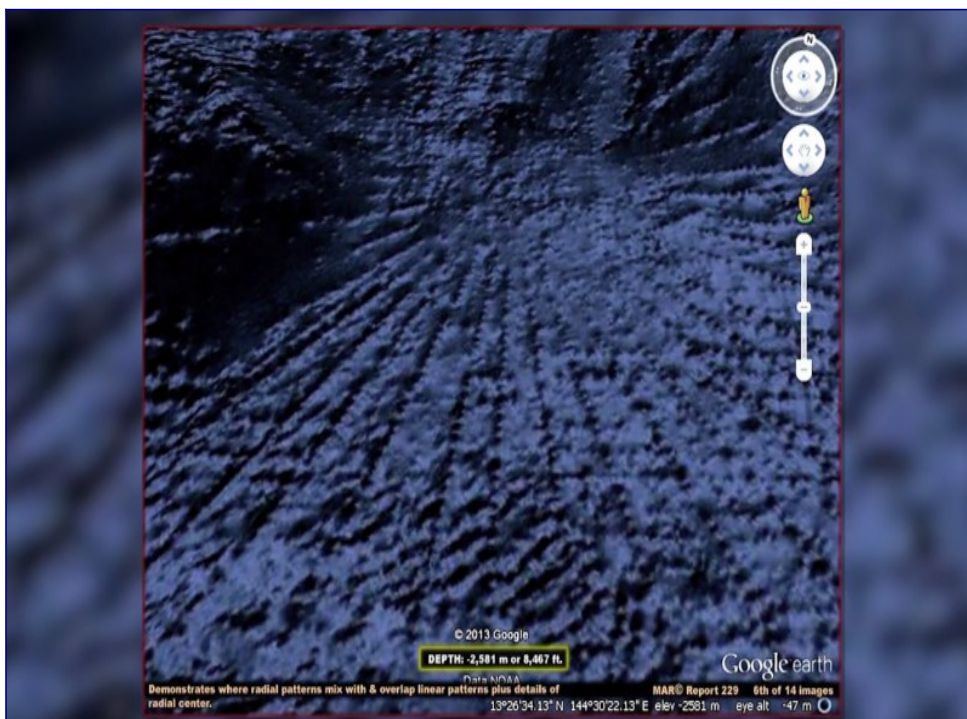

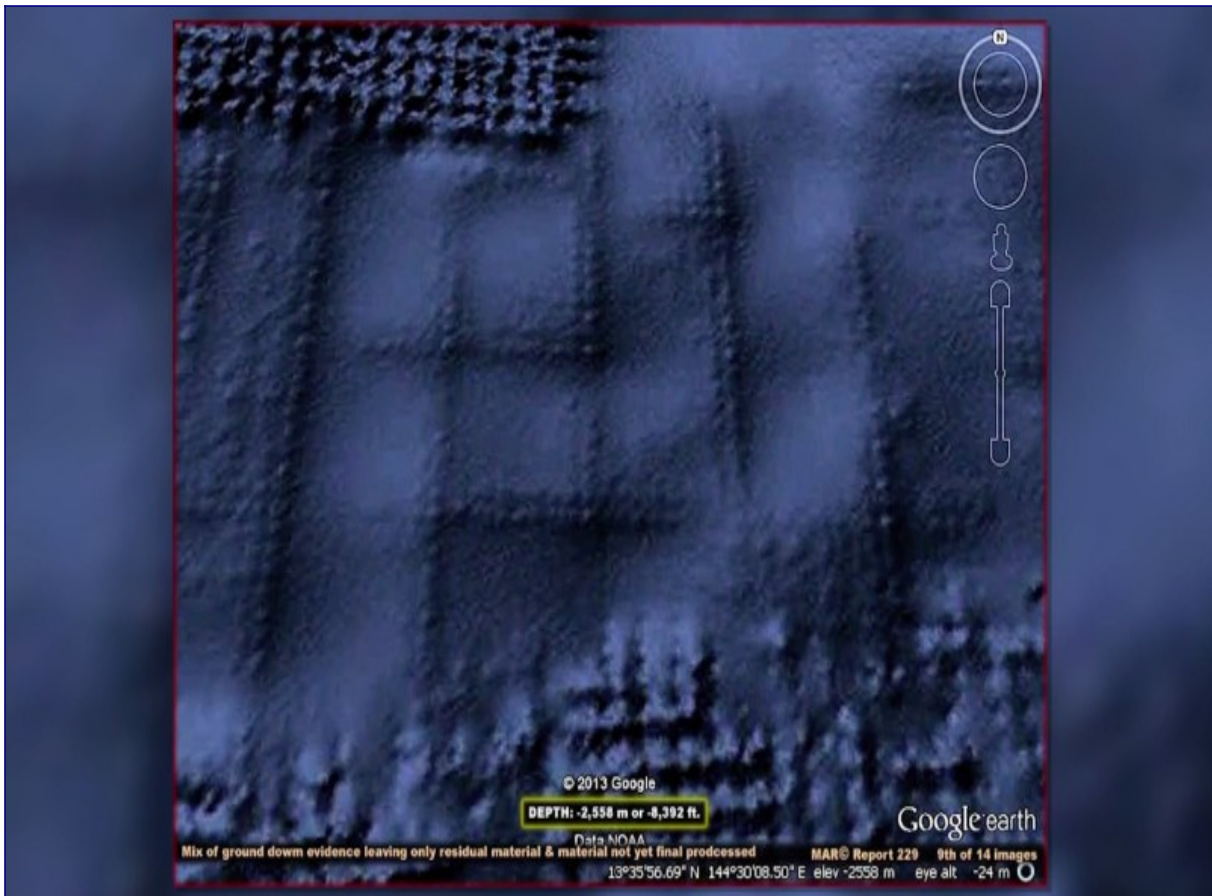
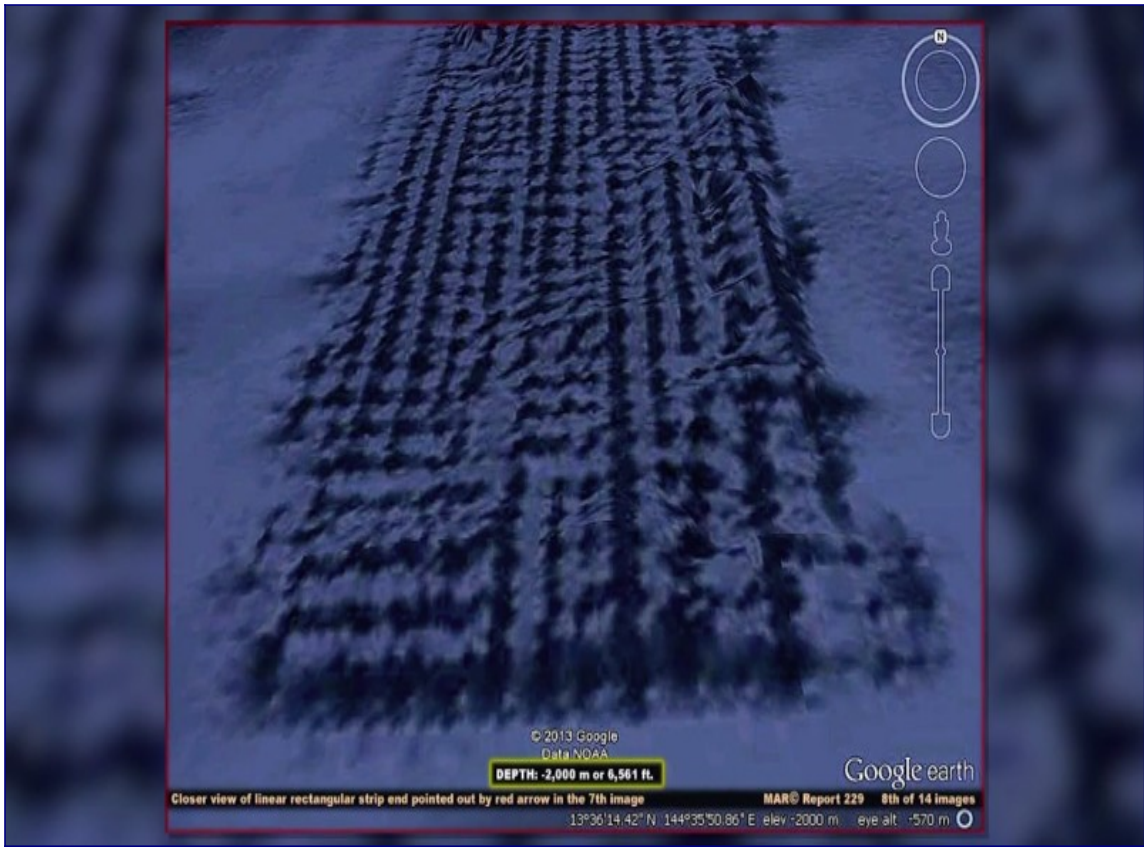

What might something like this actually be if it is not just some kind of volcanic dome underneath the surface of the ocean?

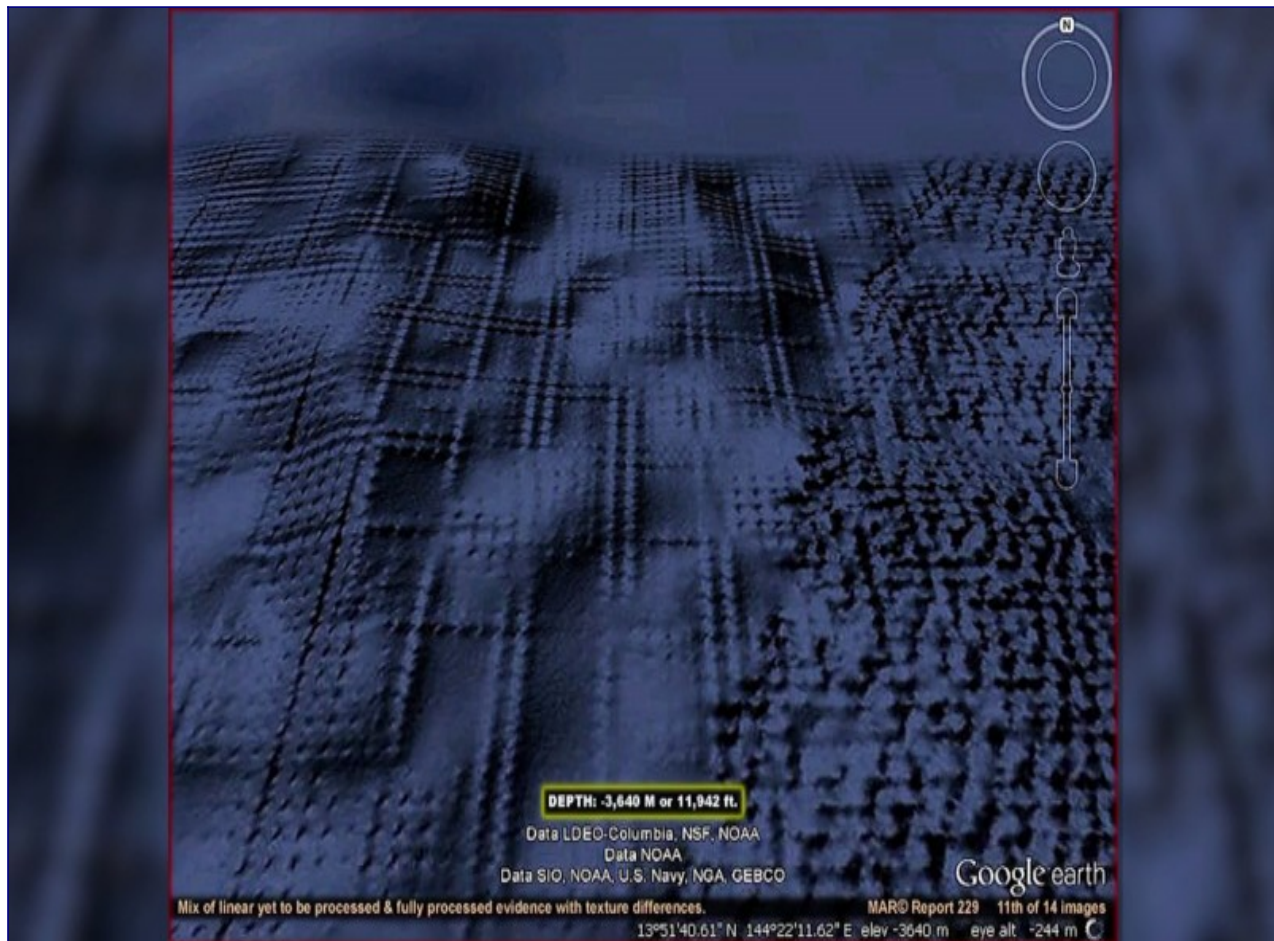

Corey: Well, if it was anywhere else, I would jump to the conclusion that it might be a kelp farm, because somewhat similar but smaller types of configurations were seen from satellites along the coast, I believe, of either North or South Korea.

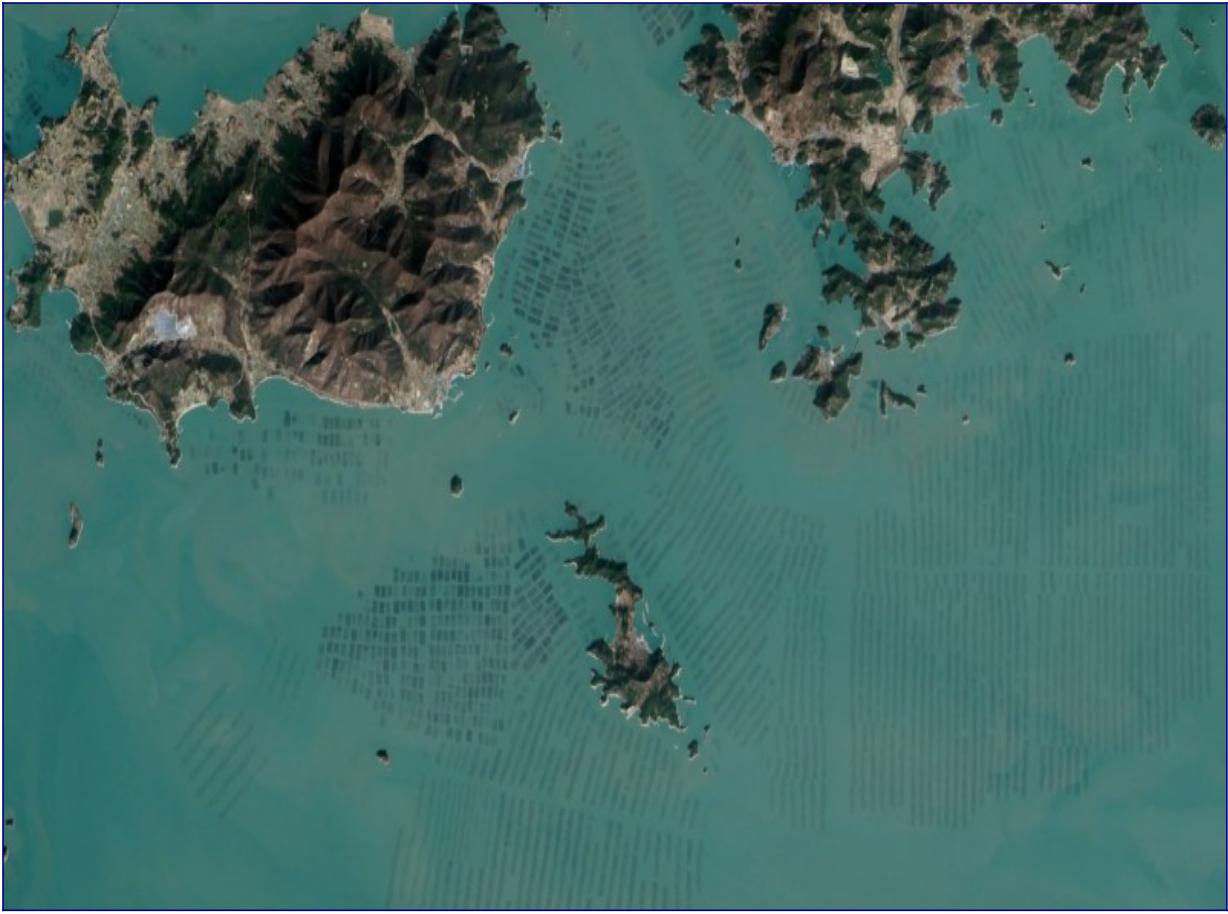

And when they went to visit, they saw that they were kelp farms.



But kelp does not grow at that depth in the Mariana Trench, and there is no one around to manage them. And these seem larger.

So it could either be some sort of underwater plant life, but it's growing in, I guess, in the rectilinear geometry that Richard Hoagland talks about, so it could very well be structures.

I'd have to get a much better resolution picture to comment further.

David: Corey, is it possible that there could be something on the sea floor where a grid-like pattern of a whole series of individual structures would then be put together in some sort of big giant grid like a rectangle?

Would there ever be a reason to build something like that on the base of the ocean?

Corey: Well a lot of the underwater bases that the Navy, and some of them are shared that even have some Coast Guard elements as a part of it, that are long cylindrical tubes that are connected together with other, almost dome-like structures, to have areas where they can perform research.

So I've seen . . . and they're modular. They will drop them from a ship or transport them underwater and let them settle at the bottom of the ocean. And then they'll have people come in with these submarines and weld them together or connect them in some other way together and build them modularly.

David: So do you also think that perhaps an interesting area of all these squares like this could be built so that you have a larger settlement where, if there's a breach in one of the areas, that some kind of airlock or pressure lock could prevent the whole area from being lost, that maybe only a few of them would be compromised before they could lock it off from the other ones?

Corey: Yes, and we can think outside the box, too. What if millions of years ago, that area, through the ebb and flow of the changes of the Earth, was once above ground?

David: Right.

Corey: Could be what used to be an above-ground structure.

David: All right, so that's all the time we have for in this episode. The Joseph P. Skipper anomalies of the Moon, of Mars, and of the seafloor on Earth. It's very fascinating, thought-provoking stuff to look at.

And these are just a few of many things that various Internet researchers have found. So we're not by any means saying this is a definitive collection. This is just some of the interesting stuff of which there is much, much more.

I'm [David Wilcock](#), here with **Corey Goode**, and the Joseph P. Skipper collection of anomalies.

This is "[Cosmic Disclosure](#)", and I thank you for watching.

Cosmic Disclosure: Wormholes and Breakaway Civilizations

with Mark McCandlish

Season 7, Episode 24

David Wilcock: Welcome back to “[Cosmic Disclosure](#)”. I'm your host, [David Wilcock](#). Well, **Corey**, welcome back.

Corey Goode: Thank you.

David: So what we're about to see here is **Mark McCandlish** describing a very fascinating UFO sighting that was certainly unambiguous way back during the era of the Vietnam War. Let's take a look.

* * * * *

THE CITY IN THE SKY

Mark McCandlish: I was at an air show at El Toro Marine Corps Station. This was back around 1991 or '92. And they had a static display there.

And they had this beautifully restored B-24 Liberator.



The aluminum of the plane had been polished to a mirror finish. And they had all the stencils were just perfect.

And I'm standing there behind this rope, and I'm looking at this plane. And I've just got a big grin on my face, just admiring what a wonderful restoration they've done on this plane.

And standing next to me is this fellow. He's probably about five foot five, an older gentleman, probably in his 70s or 80s. And he's got the same grin on his face too.

And so I look over and I said, "Boy, she's a beaut, ain't she?"

And he says, "Yeah!" He said, "I started my flying career in one of these."

I said, "Really? You were in the Second World War?"

And he said, "Yeah, I was in the Pacific theater."

And I said, "Well, so how long were you in?"

And he says, "Oh, 25 or 30 years." And he said, "I ended up my career as a navigator in a B-52 in Vietnam."

And I said, "Well, boy, that was some pretty serious fighting, especially, you know, B-52s and all the political flak that the military took."

And so we started talking about different planes and weapons systems, the different things that he had flown or been a part of over the years.

And I said, "Well, you know, I understand that there's some new, pretty advanced stuff that's flying around now.

"I've heard stories from people who were in the Persian Gulf War who saw things zipping around in the sky that were unexplainable, making right angle turns at incredible velocity, stopping on a dime, and

shooting away like they'd come out of a gun.”

And he kind of nodded and said, “Yeah, I've seen some of that stuff.”

And I said, “Really? Well, tell me about this.”

So he looks around nervously, you know, because he felt that maybe somebody might be tailing him – at least that was the way he acted.

And he says, “Well,” he says, “in the mid-'60s,” he says, “we'd flown a mission over North Vietnam, and our plane had picked up some flak from a surface-to-air missile. And so they sent us over to Guam to repair the aircraft, and we got about a week of R and R.”

And he said, “We were on our way back to our base in Thailand, and we were out over the Pacific. It's about 1 o'clock in the morning, full Moon, not a cloud in the sky anywhere.”

And he says, “I'm in my navigator suite just cruising along, not really paying much attention.”

I think they were at like 56,000 feet, some incredible altitude.

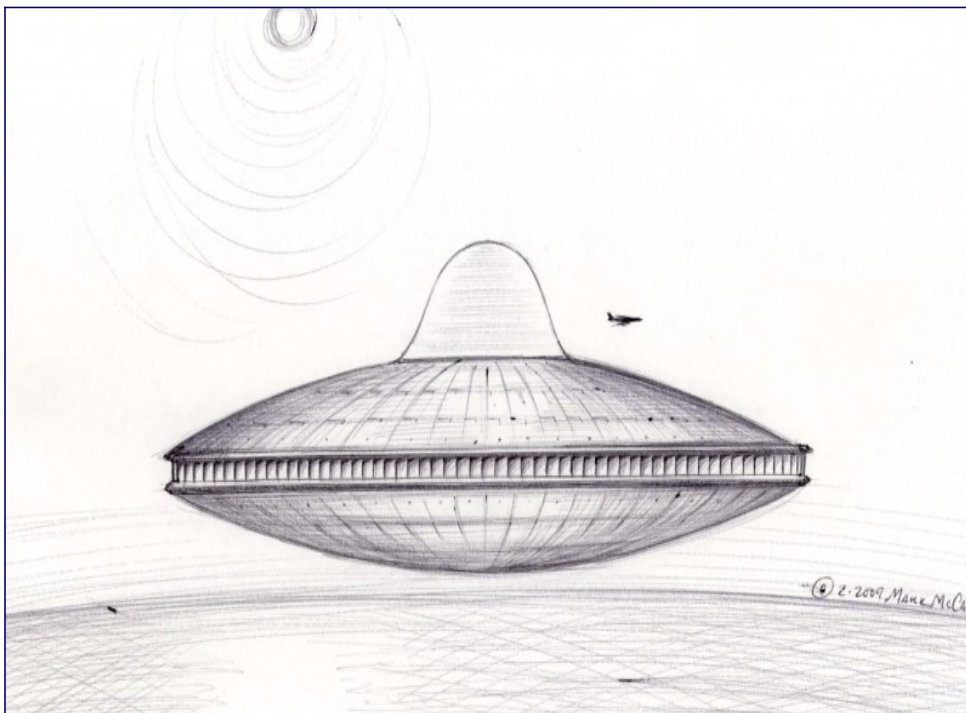

And all of a sudden, the pilot says, “What the hell is that?”

And so everybody scrambles up to the cockpit, and he points out to the left, and on the left side of the vehicle is this huge disk – immense. He said, “Conservatively, conservatively, between a quarter and a half of a mile in diameter.”

And I said, “Well, how did you . . . How could you determine . . . How could you tell it was that big?”

And he says, “Well, it had a cupola, a dome, on the top.” And he said it looked like a single casting of white Lexan. And it was translucent. And it was glowing. It was illuminated from the inside.



And he says, “On the outside of this dome, you could see the silhouette of each of the floors inside.”

And he says, “We counted 27 stories – 27 stories!”

And I said, “Okay. Well, what was the aspect ratio between the thickness of the disk and the overall diameter?”

He says, “About 10 to one.” So he says, “That's how we figured out that it was somewhere between a quarter and a half a mile in diameter.”

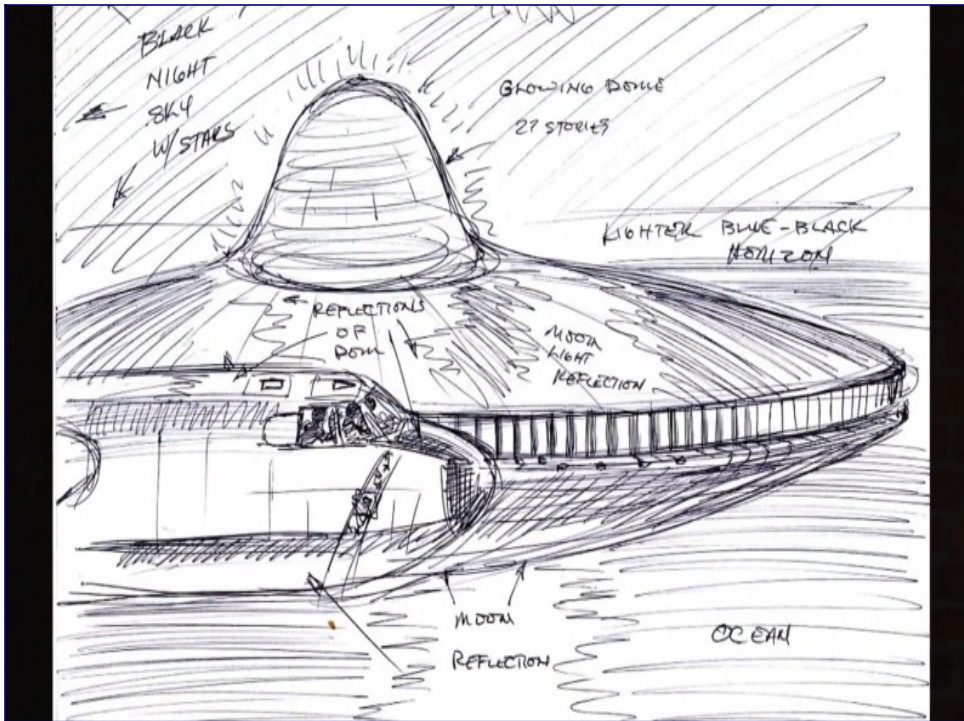

So he describes this thing. And he said, “It didn't look like your typical, you know, science fiction flying saucer where the outside is mirror smooth and polished.”

He said, “This thing was rough.”

It had panels that were different, you know, textures. And there were conduits that would come out of one place and snake around and go somewhere else, and plumbing and tubing and pipes and things, little antennas and stuff sticking out of it all over the place.

But he said, “Around the edge,” he said, “was this slot. And in this slot were these big . . . they looked like turbine blades.”

And he says, “Each one of these turbine blades was the size of a bypass door on a hangar for like an aircraft from the Air Force, really big.”

And he says, “And these turbine blades, whatever they were,” he says, “they were sliding along in this track around the circumference of this vehicle, just very slowly. And this thing paralleled our course.”

He said, "They were with us for at least a half an hour."

And he says, "Maybe it was owing to the fact that the B-52 was designed to fight a nuclear war, and so the electronics of our plane was completely shielded against EMP," electromagnetic pulse.

So he says, "Whatever was keeping this thing in the air, and we thought it was probably magnetic something," he says, "we flew all around it. We flew over it. We flew under it."

He says, "We got a really good look at this thing."

And he says, "And it was the strangest thing we'd ever seen."

But he said, "After a while," he said, "this thing moved off a little ways."

And he said, "The way we could see the features was, number one, from the illumination of the dome, and also the fact that it was sort of backlit by the full Moon."

And then the reflection of the Moon light coming off the Pacific Ocean would illuminate the underside of it.

He said, "The thing moved off a ways." And he said, "These big turbine blades at the edge began going faster and faster and faster and faster until these blades, the size of a hangar bypass door, moving so fast you can't even see them. It's just a blur."

And then all of a sudden, this thing, phew!, takes off on an oblique angle from their flight path.

And he says, "And as it did, this shimmering tunnel of light opens up, and this thing goes into it."

And he said, "And as it did, we could see at the far end of this tunnel, we could see a day-lit sky with white puffy clouds, which there were none around where we were."

And he said, "And it looked like it was coming out of a tunnel into the daylight."

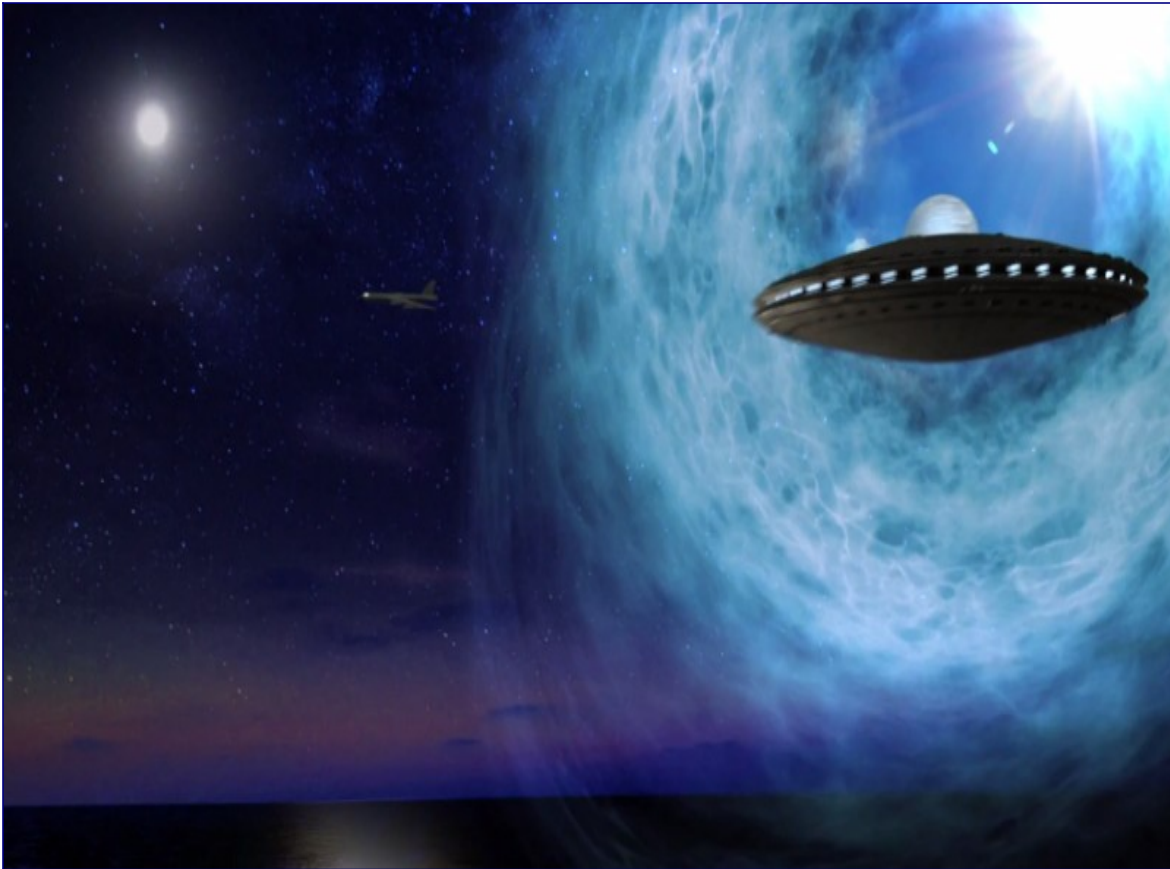

And he said, “And then the tunnel just sort of dematerialized and went away. And we were all sitting there with our mouths hanging open.”

So he said, “We went the rest of the way to our base in Thailand.”

And he says, “As soon as we landed,” he says, “the FBI was there, and they wanted to interview us and debrief us.”

And he says, “That was the one thing that they were the most interested in, this apparent traversable wormhole event that we had seen.”

* * * * *

David: Well, this is extremely fascinating. I guess we got to start with some of the nuts and bolts here, which is this seems like a more primitive type of craft except that it's very large, describing all these pipes and rivets and doohickies hanging off of it.

What do you think he might have seen back there in Vietnam? Where might this have come from?

Corey: Well, this was definitely a nonterrestrial vessel. He was describing how the cupola at the top had 27 floors. And the main section of the flying saucer, I guess we'll call it, that's where most of the engineering is, and you have a bunch of moving parts that cause this, I guess these large vents to slide around.

So most of the crew compartment is up in that cupola at the top.

David: Right.

Corey: And down inside, that's the business end where the power is generated, where the things spin. And only people who could go down there are maintaining the craft.

David: So just to be absolutely clear, nothing like this has ever been seen by you in the Secret Space Program, per se?

Corey: Well, like you said, it's older technology. And this type of craft has been associated with what people call the "Greys" a lot.

David: Oh, really?

Corey: Yeah. Or the Ebans, that these type of craft have been associated with them. Yes, I have heard of similar craft – very large, some of them like even a mile.

David: Why do you think they might have been over the Pacific Ocean near Thailand?

Corey: During times of conflict, there seems to be a lot of UFO activity, like the aliens are coming in to watch what's going on, observe, maybe even take part.

So as we heard when we interviewed **Clifford** Stone, when he was in Vietnam, they had an encounter with nonterrestrials after a B-52 had crashed.

So it seemed like during Vietnam there was a lot of nonterrestrial activity around that part of Asia.

David: The story about the wormhole at the end, of course, is really fascinating, because they're at night. They have moonlight reflecting off of this disk, but then they see a tunnel, and it's not night on the other side. There's a sky. There's clouds, and there's sunlight.

So what do you think is going on there? What are we looking at?

Corey: They're looking at their destination, a window to their destination that's been opened up.

This has been described – I don't know if I've mentioned it on the show before – but I've heard that described many times. They will see strange-looking skies that look like they're obviously not on Earth anywhere. So, yes, I've seen that described many times.

David: So if you have the right angle, you can see right through the portal and see where the destination is on the other side?

Corey: Yes.

David: How did the description of the tube itself being lined with sparkling light fit in with other things that you've seen or heard?

Corey: Well, the way I've described it is it will refract light. It looks kind of like a shimmering mirage, is what I've seen.

David: Well, it's fascinating to me, because **McCandlish** doesn't know what I heard from Daniel, another insider, who described working at Montauk, and that portals would appear in the cafeteria.

And you would see like a grassy field where there was no field. Like you'd be looking at the wall, but there's this shimmery thing around the wall and then there's this field.

Now, do these portals take you through time as well as space?

Corey: Yes. And they learned how to manipulate some of these portals to be able to travel backwards and forwards in time even.

David: All right. So now we're going to have more of this interview with **Mark McCandlish**, where he's going to describe his own personal experience.

* * * * *

THE FLASHER PHENOMENON

Mark McCandlish: I was coming back from an Angels' baseball game in 1994 – I think it was June or July at Angel stadium – going east through Carbon Canyon.

There's an area there near some kind of a wildlife preserve that's southwest of Chino.

In the distance, there were some heavy duty high tension power lines that went over the hill, and there were some developments, some houses, and things in there.

I'm with a group of two or three other kids, and we're in this car driving along. And there was a Santa Ana wind condition in that area at the time, and so all the planes that would normally come in and land from the east really couldn't do that because the wind was coming in from their back, and it would lower the amount of lift they'd get.

So they were orbiting around and coming in and flying in from the west, going towards the east to have the extra lift of that wind. And so there were all these planes in a holding pattern, and you could see their lights and everything.

And I said, “Boy, you know, it must be quite a challenge for the air traffic controllers to keep all those planes organized and not have any one of them crash.”

And we had just finished talking about UFOs. This is the thing that was so fascinating.

And right as I said that, about the crash and, you know, a midair collision, there was a brilliant flash of light. And we all kind of went like this [*Mark shows shock on his face*].

And this brilliant flash of light gets big, and then it kind of closes back up.

And then there's another point of light that starts coming out of the sky, and it's dropping down about a 45° angle and it's getting bigger as it does so.

And then it was almost as though there was an invisible hole in the sky and following in unison and in trail with this object were these parallel lines. And they were moving in unison. And they were all sort of staggered. They all had different line weights. Some were thick; some were thin.

But they were all the same sort of golden yellow color, and they were moving in unison with this thing.

And I thought about it. I called the airport. I said, "Was there a crash? Was there a collision?"

"No."

And so as I was thinking about this, it occurred to me – and this thing came right down into this wildlife preserve. And they have very strict guidelines about no one being in the park after dark. There are signs that say so. I investigated this.

So they don't want you around there after dark. And now I think I kind of know why.

But the object that I saw appears to have just exited from one of these traversable wormholes.

And just like in that scene in the very first "Star Wars" movie where they make the jump to light speed, and as they shoot off into hyperspace, all the images of the distant stars begin to streak.

Well, it's the same thing coming the other way, because what's happening is that as this thing is coming out of this traversable wormhole, it's actually dragging some of the light from those stars where it was when it left some point in space. It's pulling that light along with them.

And so what you see is the image of those stars sort of stretched out into lines. Each star, the big ones that are closer have a larger or heavier line weight. The ones that are faint, further away, have a little tiny line. But they were all parallel, moving in unison like this.

And then I realized that the golden color was the red shifting of the light from stars that looked like white to the naked eye. But if you're talking about the Doppler effect of moving away from a light source, you get a red shifting so the light turns sort of a yellow gold.

And that was how I figured it out.

Well, since that time, since I recognized what the phenomenon looks like, and since I moved to Northern California, I've probably seen events like that maybe at least six to eight times – a couple of them quite spectacular.

But they're so often, they're so frequent, especially in the summertime. We don't know why. The summer seems to be a time frame when this happens more often.

But they happen so often that the local people who watch the skies, and you know, astronomy fans and people who like to watch UFOs or wait and see if they see one, they call these things “flashers”, because they happen so often.

* * * * *

David: When he's describing this portal phenomenon with lines coming off of it, what are your initial thoughts as you see all this?

Corey: A lot of optical types of phenomenon have occurred. Even light can get stuck in the wake of these craft as they travel through these wormholes.

So I've heard of different types of light phenomenon that have occurred in air when craft have entered and left through wormholes.

David: He talks about these flashers as if they're fairly common. I haven't really heard people describing that. Do you think that if someone such as either an extraterrestrial or one of our own are traveling in and out of our atmosphere using portal technology, that if you are perceptive enough, and you're looking in the right place at the right time, that there will be visible phenomena like this?

Corey: There's a lot more going on above our heads than we know. The typical person spends the whole day looking at ground level. Very few people stop to look up.

David: Right. So you think there could be atmospheric phenomena that most people wouldn't even notice because it's fast or otherwise not so visible?

Corey: Atmospheric and light phenomenon, yes.

David: Right. In a case like what we just heard him describing, would this be more like a craft? Or would this be more like a natural phenomena in some way that bends light as a portal phenomena?

Corey: It could be either, because as I've described how the cosmic web works, and how the Earth, as it spins, there has to be the correct electromagnetic connection between the Earth, the Sun, and then the Sun and the star of the destination that they're coming from.

So this could also explain why they're only seen in summer, or possibly, because that's when these portals are opening over certain nodes on Earth.

And as I've described, these electromagnetic nodes can open below ground, below the ocean, on the surface of the Earth, and extremely high in the atmosphere.

David: One of the things that he made me think of was something I saw in "Discover" magazine in the 1990s, where they were describing a new phenomenon that they were announcing that wasn't really Aurora Borealis, but had some similarity. And they called them "sprites". That was one type.

Another type they described as "elves".

And when I think back about this now, the sprites and the elves predominantly were linear columns of light that seemed to have a mouth, like a funnel type of shape to them.

So do you think sprites and elves might be an example of these wormholes actually being visible to us?

Corey: No. No, those are electromagnetic phenomena that happen. Some have negative and positive charges. A lot of the electrical charges that we see coming and grounding, hitting the ground, are of one polarity or charge.

And the ones that reach out into outer space are of a different polarity and charge.

David: Okay.

Corey: And they reach very far out into space, the sprites and the elves.

David: Well, I thought you said that portals themselves have a plasma basis to them?

Corey: Plasma is more of a byproduct of the electromagnetic fluxing that's occurring. Just like he was talking in the Flux Liner how it would create kind of a corona around it of light that emitted x-rays.

David: Right.

Corey: It's more of a byproduct.

David: One of the interesting things he said in the course of this little section was that whatever was coming through this alleged portal appeared to be getting larger and larger as it got towards him.

Do you think that that size increase was simply a function of the object moving nearer to them? Or is there something else going on here that causes that?

Corey: When we would go through these local distortions in time-space that we call portals, I've described how there would be like a metal beam, and then the portal would be turned on and it would fold up and go in.

And I've described how it'll be a three dimensional sphere, and people will walk in from all directions at the same time. And then on the other side they pop out going that direction.

Well, as they go in and come out, there's such a twisting in time-space that as they go in, they seem to shrink. And as they come out, they seem to kind of grow larger.

So when I saw him describing that phenomenon, it could be perspective that it was coming closer to him. But it made me think of that weird anomaly that occurs when people and items go in and out of these portals.

David: Do you think that there is some sort of connection between megalithic stone architecture and portal phenomena?

Corey: Yes. The ancients built a lot of these megaliths along this grid system on the Earth.

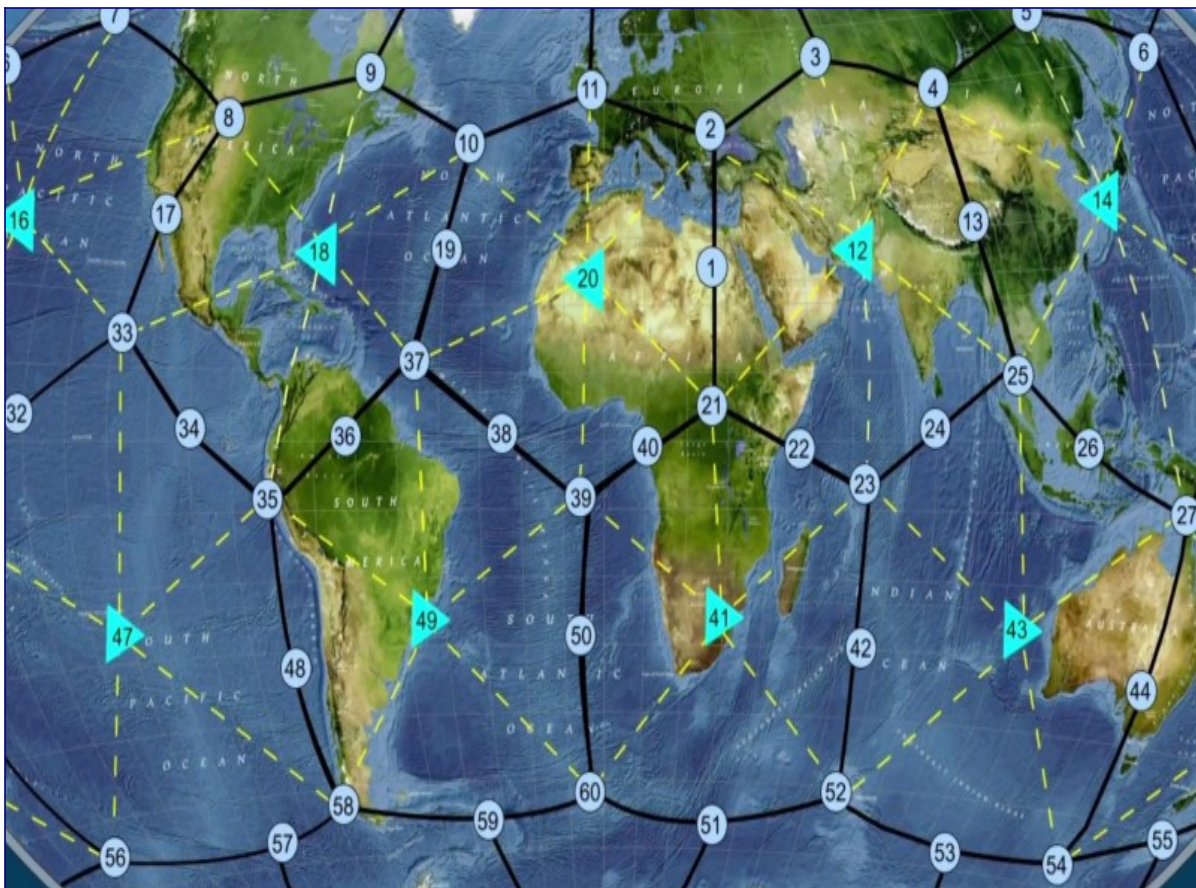

And this grid system is what conducts the electricity and channels it to these different nodes . . .

David: Right.

Corey: . . . that open up into portals.

David: All right. So our last and final section of this groundbreaking interview with **Mark McCandlish** is where he describes his interpretation of a term that was coined by Richard Dolan, the wonderful UFO investigator who really is all about the facts.

He termed the idea of a breakaway civilization being something that could arise out of this culture of national secrecy, and how these back engineered UFO anti-gravity technologies could, in fact, be colonizing outside the Earth, and therefore, form a civilization that is totally isolated from us.

Let's hear what **Mark McCandlish** has to say about this fascinating concept.

* * * * *

BREAKAWAY CIVILIZATION

Mark McCandlish: I think my friend Richard Dolan was one of the first people to speculate that this kind of technology sort of sequestered and held away from public view might have such a consequence that there might be a population of people who are held to a higher standard of security.

That are selected for their intelligence, their abilities, their understanding of what makes these kinds of things work. And that people who get involved in these things can . . . in all likelihood, they can never talk about them. They can't describe the technology. They can't divulge what they know.

And so they may, as a consequence of that, establish their own society, their own groups, their own peers, where they congregate and hang around together.

I mean, there's probably some kind of a location, maybe in Antarctica. I mean, there's been a tremendous amount of interest in what's going on in our Antarctica.

I mean, you hear John Kerry, and, you know, people like Richard Branson, you know, they're all flying down there for God knows why. But there's something very interesting happening down there.

There's been a lot of suggestions that Admiral Byrd had a confrontation with an advanced technology, you know, isolated civilization down there right after the Second World War. But there were losses of aircraft and personnel and a few ships, you know, as an outcome.

The technology is real. I know that I've seen things that were unexplainable by conventional types of propulsion systems or technology – things that moved across the sky at incredible speeds, things that look like they're manipulating time at the same time.

And so if you have a society that has at its disposal this kind of physics, this kind of technology, it seems to me that under the right circumstances that kind of technology could be used to do a little arm twisting around the world, in terms of things that are happening politically, for good or for bad.

It might be a way of encouraging someone not to start a third world war. It might be a way . . . I mean,

you know, when you see the Chinese doing a lot of saber rattling and then all of a sudden there's a major UFO sighting over a capitol like Beijing, it gives one pause.

It makes you wonder if they aren't being given a very subtle message to stand down.

* * * * *

David: What we seem to be driving at here is a concept of a much greater amount of secrecy behind the UFO phenomenon than most people could ever imagine.

And that's obviously been a central element of our show. I thought it was interesting that he mentioned Antarctica and brought up a lot of the same data that we've been talking about, seemingly without any awareness of what we have disclosed.

So what was your feelings on that?

Corey: Well, especially in connection with a breakaway civilization, because one of the updates that I have delivered recently is that there is what is referred to as an Antarctic Area 51, that is in Antarctica, that they have a lot of these under ice bases that they built under Project Iceworm.



They're very large, and they're research and development facilities. Lockheed Martin, all these places, they inhabit them and they use them.

Not only that, but there is a spaceport there that used to be a Nazi spaceport that was handed over to us during the late '50s, early '60s, and we converted it into our own spaceport. And that is a very heavily used spaceport.

But let's not forget that the concept of breakaway civilizations is not new. It occurred in antiquity.

Ancient civilizations would have the priest caste, and the priest caste would be made up of engineers. And all of the knowledge was guarded by the priest caste. They would even keep it from the kings.

In these times when they had developed these types of technologies, they had developed them separate from their civilization. And many of them would go below ground, off-world, develop bases.

And some of them are around today as some of these nonterrestrial groups – what we think are nonterrestrial groups – that we see flying in the sky.

David: What do you think is the likelihood of this breakaway civilization ever actually healing this divide with people on Earth to the degree that we will know that it exists and be able to interface with it in some way?

Corey: I'll be very surprised if they self-identify. I mean, the full-on breakaway civilization that has the most advanced technology. We'll most likely hear about one of these other secret space programs before too long.

But the only way I see that being disclosed is through some mass data dump, or some sort of an event to where the information is put out against the will of The-Powers-That-Be that run these breakaway civilizations.

David: How do you see that unfolding though? Because it seems like part of how this breakaway civilization concept has worked is that we don't have the ability to send our own drone and orbit the Moon to look at what's on the dark side. We don't have the ability for ordinary folks to get out into space.

Then you have guys like Elon Musk and Richard Branson who create their own little space program, and they try to make a launch, and it blows up, which appears to be sabotage.

So how would we actually experience this? How would we get out there?

Corey: Well, all of these things are occurring in secret. The weapons, the programs that are, let's say, sabotaging those two civilian programs, this is all happening in secret.

If we have some sort of a data dump and a large amount of information comes out that really can't be disputed, then the ruse is over. They can hide behind the curtain all they want, but we still know they're there.

David: What do you think is the end game as far as the breakaway civilization is concerned? If they still live in our solar system, they're kind of like sitting ducks if there was some kind of disclosure.

If they really wanted to break away, wouldn't they cut the cords to our Solar System completely and just go somewhere else?

Corey: They have. They inhabit other star systems. They have bases in other star systems.

If they had to, and they had planned to, at some point when it looked like information was going to be divulged to the public or to the middle tier – people that have teeth, some of the military-industrial complex groups – if these people started to have this information disclosed to them, The-Powers-That-Be that are part of this breakaway civilization had planned to escape our Solar System and go to one of these other star systems.

David: How do you think this so-called outer barrier affects that plan?

Corey: It has destroyed that plan. They are stuck here with us.

If we get Full Disclosure, then like you said, they're sitting ducks. They've been identified, and everyone's going to be taking a good look at them and what they've done to keep their breakaway civilization a secret from us, which is where a lot of the meat of disclosure is going to be.

David: All right. Well, on that note, we're going to end this episode. Very, very fascinating series of interviews with **Mark McCandlish**, one of the original 39 Disclosure Project whistleblowers who I got to meet personally back in 2001. And it is really amazing to hear how much more he had to say.

I'm **David Wilcock** here with **Corey Goode**. This is "[Cosmic Disclosure](#)", and we thank you for watching.

Cosmic Disclosure: Darkness on the Far Side of the Moon with Niara Isley

Season 7, Episode 25

David Wilcock: All right. Welcome to "[Cosmic Disclosure](#)". I'm your host, **David Wilcock**. I'm here with our insider's insider, **Corey Goode**. And we have a very special guest, **Niara Isley**.

So **Corey**, welcome to the show.

Corey Goode: Thank you.

David: And **Niara**, welcome to the show.

Niara Isley: Thank you very much.

David: For the purpose of our viewers, let's assume they haven't read your book yet. They probably are going to want to after seeing this.

You started out in the military.

Niara: Uh-huh.

David: So this is how you got into that. So could you just give us a little backstory of how this ended up happening to you?

Niara: Well, I was in the Air Force from 1979 to 1983.

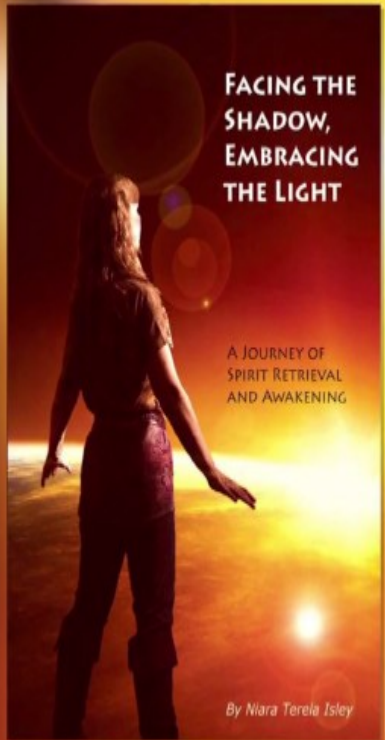

I was an auto track radar specialist. That's a surface-to-air missile and anti-aircraft artillery radar.

David: Okay.

Niara: And there's a sweep-the-sky radar, like an air traffic control radar. And then it calls up different radar sites and said, "You have an incoming aircraft at such and such degree of elevation and azimuth and this range, and please point your radar in that part of the sky and see if you can pick up this guy, track him for five minutes."

And then if we tracked him for five minutes, it was considered a kill.

David: Right.

Niara: And basically, an auto track radar paints a very tiny target on an aircraft. And it's a targeting point. So then if we were an active SAM site, surface-to-air missile site, then we would push a button, fire a missile, and blow that plane out of the sky.

What we were doing was teaching pilots to fly against radar to increase their survivability in a wartime setting.

David: Ah! And where did this start? Where were you stationed?

Niara: I was stationed at Nellis Air Force

David: Nellis? Wow!

Niara: In Nevada.

David: Now that's one of the ones that, if you've ever studied UFO lore, we hear a lot about.

Niara: And then I was part of a group that was bused up to radar sites in Tonopah and Tolicha Peak once a week, every other week.



Nellis Air Force Base



Tonopah Test Range



And then we would go out and do our job. And it was during that time, when I was at Tonopah, that I was taken in the middle of the night out to test the radar on “special aircraft”, which were extraterrestrial or back-engineered extraterrestrial craft.

David: So I guess first of all, just one more question would be, what was the rank that you held at the time that this happened?

Niara: I was an Airman First Class.

David: Okay. So how long had you been doing this job before you got this “special assignment”?

Niara: I was brand new to the job. '79, April of '79, I went in. And then after boot camp and so on and so forth, and then I went to Nellis after the beginning of the new year in 1980.

David: So this is exactly when Reagan takes control of the White House. And as you said, **Corey**, that a massive influx of financing goes into the military-industrial complex and this Secret Space Program.

Corey: Yes, And this is also . . . around 1980 was when Solar Warden was launched.

David: So they told you that it was a special radar assignment and special craft or something?

Niara: They didn't tell you much of anything. They just treat you like cattle. You're just a person that knows how to run radar, so you get picked up. You get taken out there. You put on the scope, and you do what you're told.

We were given fatigues to wear with no rank insignia and no name tags. We were forbidden to speak to each other beyond what was necessary to run the radar and try to track the aircraft.

They effectively isolated us from each other through fear. "Don't talk to each other – other than what's absolutely necessary – and we're watching you all the time."

David: This was in general, not just on this special assignment.

Niara: This was in general. This was in the special assignment.

David: Oh, in the special assignment.

Niara: Uh-huh. Because during the day in my regular job, I would wear my regular fatigues with name tags and patches . . .

David: Right.

Niara: . . . and stuff like that. But these fatigues were given . . . nothing identifying whatsoever. They didn't want us to have any means to search through our memory and think, "Oh, I saw this name tag," or "I saw this patch," or "I saw this whatever identifying mark." They wanted to try to keep everything as generic as possible.

David: Other than **Corey**, I've had several insiders who I've spoken to who worked in what we could call the Secret Space Program, and THE MOST consistent element you hear from all of them is they're not allowed to talk to each other.

If they get to talk to ETs, they're only allowed to talk about what their job is. They're not allowed to ask any questions outside the assignment. And it's a very repressive environment in which if you so much as very slightly deviate from these guidelines, you could get a butt of a rifle in your head kind of thing.

Niara: Yeah. Mhm.

David: And **Corey**, of course, also has had the same experiences. In fact, we just were talking about you being picked up by these military-industrial complex people and that the guy was not wearing any . . .

Corey: Yeah, they were airmen. It was Air Force. And they weren't wearing the fleur or any patches.

Niara: Yeah.

David: Those are the little details that I notice as a researcher, doing this for 20 years, talking to insiders. So many things pop out that just can't be coincidence.

Niara: Right.

David: There's too many things that line up.

Corey: I had a question.

Niara: Sure.

Corey: When you were on this special assignment to using radars to paint unknown craft for the anti-aircraft batteries, can you describe . . . were you able to get a good look at these unknown craft?

Niara: I didn't get a good look at it from inside the radar van, in front of the scope. But when we were done with the test, and we went out and stood on the deck of the radar van while, I assume, officers were inside the radar van discussing the results of the test . . .

From my standpoint, we couldn't track those things. They could literally appear in one part of the sky and then blink out and be someplace else. So they couldn't be tracked.

And I think that's what they wanted from the test, that they couldn't be tracked.

So when I was standing out on the deck of the radar van, then yes, I did see the craft. I saw probably as many as 12 to 15. I didn't get an exact count.

What I focused on was the one that was closest. It was maybe 50 to 75 yards out. It was huge, saucer-shaped, glowing orange on the bottom.

David: Oh, wow!

Niara: And the bottom was like a transparent sort of skin or really thin metal.

And it looked like there were lights kind of lighting up in sequence around the bottom of the craft.

Corey: Shining through it?

Niara: Shining through the metal, yeah. And so I was watching it, and there was a sound coming from it that was like speakers at a rock concert when there's no music coming through and they're just sitting there kind of humming with a little static. That was the sound.

And then there was the vibration and feeling coming from it, too, even at that distance.

Corey: Yeah, that's still pretty close.

Niara: Uh-huh. You could kind of feel a little prickle in the air because that thing was putting out a hell of a field.

David: Were you tracking these unconventional aircraft all the time? Or was it just when you did this assignment at Tonopah?

Niara: Just when I did this assignment at Tonopah where I got taken out in the middle of the night, because usually, I had a day job where we would go out and we would track regular aircraft, you know, F-16s, F-4s, and whatever was out there flying to try to train pilots to fly against radar.

David: So when you got brought in to Tonopah for this special assignment, in the beginning, you're just tracking these unconventional aircraft. Or did you get abducted right away?

Niara: The primary job was the day job, and then this night thing would happen every so often. They'd come and get me in the middle of the night, and then it would be the weird things.

David: When you say "the middle of the night", like what time?

Niara: After midnight, between midnight and 2:00 AM.

David: That's exactly when they would pick you up. [**David** is speaking to **Corey**.]

Corey: Hmm.

Niara: Yeah.

David: Same thing. So did you . . . Were you aware . . . Let me ask you this. Did it begin just with you tracking these unconventional aircraft before any type of abduction took place? Or did the abductions start at the same time as you were tracking the unconventional aircraft?

Niara: To my knowledge, the abductions started at the time I was tracking the aircraft.

David: Okay.

Niara: But I am an abductee of the Greys, or an experiencer of the Grey abductions since childhood, early childhood.

David: Oh.

Niara: And I write in my book that I had the distinct impression that the people that were working with me in the military knew that I was an abductee.

Corey: **Clifford** Stone!

Niara: Mhm.

Corey: That reminds us of **Clifford** Stone.

Niara: Yeah.

David: Well, it's also what you've said, **Corey** . . .

Corey: Right.

David: . . . that these MILABs are . . . They know who's being abducted.

Corey: They do.

David: They track everybody who's abducted.

Niara: And there's another guy, Dan Sherman. He wrote the book called "Above Black: Project Preserve Destiny" is the title.

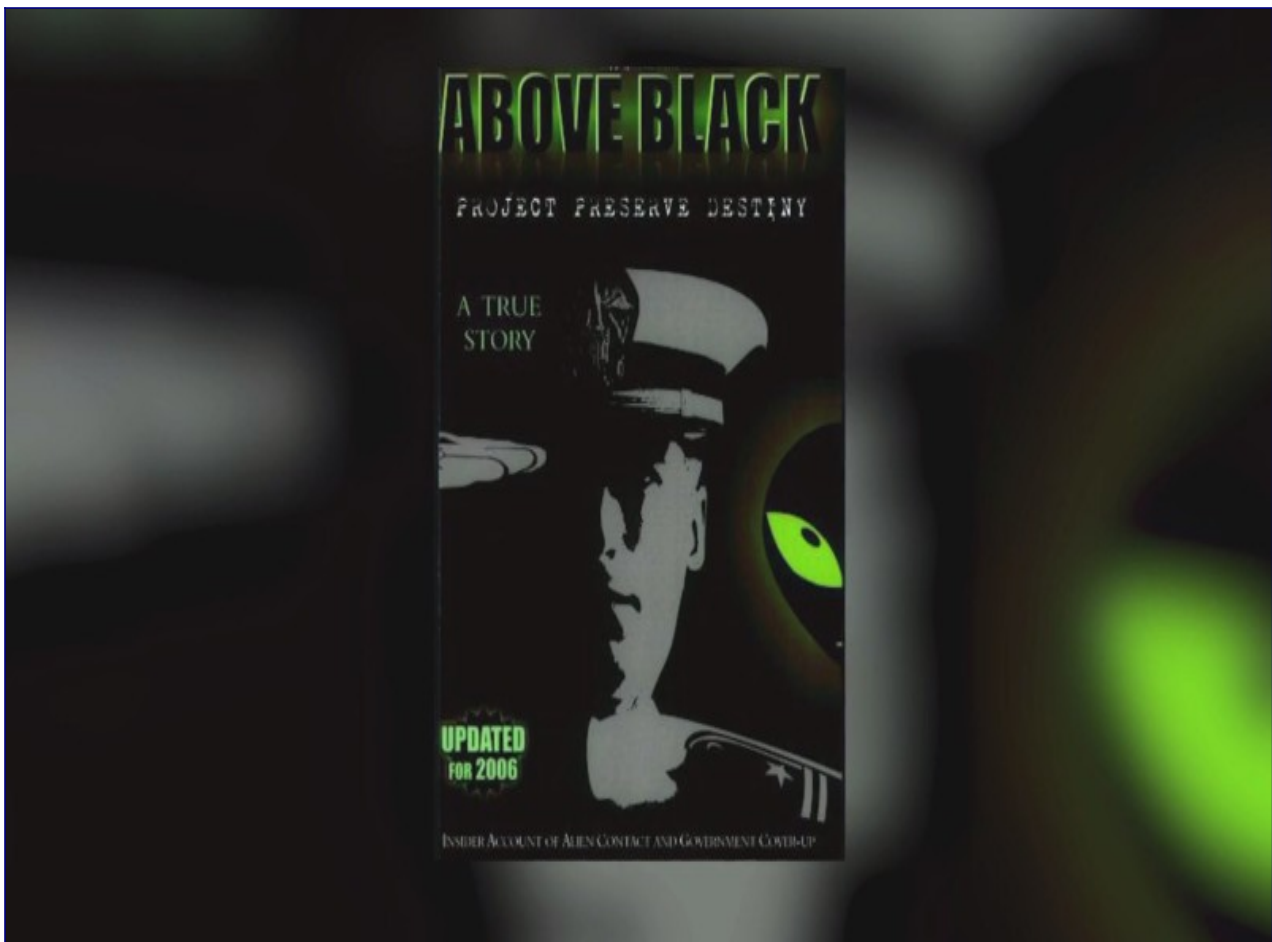

And he said the same thing. He was trained as an intuitive communicator, again, isolated from his other training companion, not allowed to speak to each other, the whole MO right there.

David: Right.

Niara: Uh-huh.

David: Obviously, by the time this has happened, big movies like “Close Encounters of the Third Kind” have come out. So when you're seeing these craft, are you thinking, “Okay, that's a flying saucer, that's a UFO”? Or were they trying to tell you it was one of ours?

Niara: No, they didn't tell me anything.

Corey: Yeah. Need to know.

Niara: Yeah. They just did that.

And the other thing about Dan Sherman's thing that's really important is as an intuitive communicator, he was tracking people who were being abducted by the Greys.

David: Right.

Niara: It's really important because he would be the one that supplied the information about people that are being abducted by the Greys to the military.

David: Right.

Niara: And you wonder about it. Why do you take somebody who's already had extraterrestrial experiences? Maybe because the shock of seeing the technology won't be quite so much if you're working with an abductee, or this or that. You can come up with all kinds of different reasons.

Or maybe there's some special faculty that I have as a human being that other human beings that aren't taken don't have. I don't know what it is, but I would certainly love some answers.

David: I'm just wondering if there was a point before maybe things really got traumatic and horrible where you had that moment of, "Wow! These are UFO's! They're having me track UFOs! This is amazing."

Niara: Yeah.

David: Did that happen?

Niara: Mostly, I was just scared, because I only had a "Secret Security Clearance" at the time.

David: Oh.

Niara: And I thought, "What I am seeing is classified so far above 'Top Secret' that this is scaring the living hell out of me. It is scaring the living hell out of me that I'm even seeing this."

And I was right to be scared because after we were done there, we were put on a bus with painted-over windows and taken to what I either . . . it was either Area 51, at an underground facility there, or I've recently heard that there was an underground facility at Tonopah.

And then we were put in a waiting room where . . . let's see . . . The chairs were diagonal. So if the

room was square here, the chairs were set out diagonally with the backs here. We were facing this way. And behind us, there was a double door with light coming in from the hallway. But the lights were off in the room. [In other words, the people sitting in the chairs were facing the dark part of the room. The double doors and the light from the hallway were behind them.]

Again, my thinking is they were trying to disguise any details that might be shown by light to keep us, again, kind of in shadow with each other, so that we were forbidden to speak to each other. But if we were sitting next to other shadowy experiencers next to us, you know, you get the idea.

Yeah. They just wanted to do it. And then they called us one by one. And I've told this story so many times.

They called us one by one into this little room.

When it was my turn, I went in there. I laid down on a stainless steel examining table, fully clothed, and laid there for the longest time.

And there was a security guard with a sidearm standing at parade rest in the room, kind of next to the wall at the foot of that examining table.

Then finally, a guy came in with a white lab coat on, saying, "Stay calm," three times in a real deadpan voice.

And when he walked around my right side, he came up with one smooth move. He had a . . . In his hand was a hypodermic needle, and he came up, one smooth move, and injected me in the side of the neck with some unknown chemical that put me immediately into chemical trauma.

And then, suddenly, two guys were on either side of me, on either side of the table, lifting me off the table and taking me down a very long flight of stairs.

And I was thrown in a little booth where I went through the effects of the injection.

David: When you say "chemical trauma", what does that mean for people who don't know?

Niara: It was like having an instant seizure.

David: Oh, wow!

Niara: It was like [**Niara** throws her head back and her body shakes uncontrollably.] . . . like this. And the chemical went straight to the brain. Wherever they injected it, they wanted it to go straight to the brain.

David: Wow!

Niara: I was shaking. I couldn't really move. It was consciousness altering.

And here . . . this is an unusual supposition, but it's just a supposition based . . . It's an educated guess based on the experience and a few other things I've kind of put together in my own mind.

But because I've been a spiritual person my whole life, meditating and all kinds of spiritual inclinations and pursuits, I have to wonder because of the effects of the injection. I mean, I felt like I was going to . . . that the molecular bond between my molecules was being dissolved, and I was gonna dissolve and run through a drain in the floor of that little booth that they put me in.

It was really a terrifying feeling.

David: What were the effects on your consciousness? Were you able to have clear thoughts, or did you start to become very discombobulated?

Niara: I didn't have clear thoughts until later.

David: Okay.

Niara: But I had major psychic awakenings. I remember waking up in my bed in Las Vegas, Nevada, in the apartment that I was renting at the time.

And one morning, I woke up, and it was like all of reality just looked absolutely as fragile as it could be, like all I would have to do is blink or sneeze, and reality would shatter in front of my eyes.

And I closed my eyes again, and I said, "Whatever's going on here, it's really, really disconcerting, and

it's kind of scary, and I want it to go away.”

And then when I opened my eyes again, things were more normal.

David: Corey, you've talked before about psychic training that's being done that involves injectables that seem to do something to consciousness.

So could you just briefly touch on that a little bit to what we're talking about here?

Corey: Yes. These were pharmaceutical medications that they would give people on a regular basis to enhance your intuitive abilities. And they would give people these types of shots, as well, that were remote viewers or remote influencers. So that is consistent.

Niara: I just felt scared, and I remember curling up in a fetal position in, like, a little ball with my arms around my knees on the floor of that booth.

And I just went through the effects of the injection, and I screamed and screamed and screamed.

David: Wow!

Niara: (Sighs) And then – this is really hard – and I had a hard time even believing this because I just didn't want to believe that other human beings could be so cruel to one of their own species.

But I was dragged out of that room after the effects of the injection were wearing off, and I was sexually assaulted by two security guards while eight people watched.

And one of the people watching was a Grey extraterrestrial.

David: My God!

Niara: And the Grey, interestingly enough, maybe because of my childhood experiences with the Greys and through young adulthood, maybe I'm sensitized to their telepathy, but I could have sworn that I heard the Grey thinking that he was kind of incredulous that human beings would do this to one of their own kind, that they would subject them to that kind of violence.

David: Wow! Did there seem to be any difference in how the Grey was treated as opposed to everyone else? Did it act differently, or were people treating it differently?

Niara: I have gotten the impression that some of the people in the chairs didn't want to be there. They didn't want to witness what they were witnessing because they were saying to these guys, probably, something like, "Well, if you ever talk, this is what your wives or daughters or sisters are gonna get."

David: Were they having a similar type of uniform that had a lack of discriminating characteristics on it?

Niara: These were people in civilian clothes.

David: Oh, civies?

Niara: Mhm.

David: Okay.

Niara: Yeah, the people sitting in those eight seats were civilian clothed, or there was the E.T. And then the military people in the room . . . They may not even have been regular military. They might have been military contract workers.

David: Right.

Niara: And I say that because our regular military are mostly pretty good people, you know?

Corey: Yes.

Niara: I don't think they're gonna lend themselves to that kind of thing.

I also thought that the one blond security guard who was so brutal to me, I think that he might have been a psychopath or a sociopath that they got out of prison and put to work doing this kind of stuff because he had no conscience about doing horrible things whatsoever.

Corey: Yeah, they look for those types of people for these programs.

Niara: Yes. Uh-huh.

Corey: And also, I'm very familiar with them using sexual trauma to remove memories or to control a person on a very deep level.

Niara: Uh-huh.

David: Did anything else happen to you after the assault? Or did you just get brought back to your original base?

Niara: I was injected with something to put me to sleep. And then I assume they loaded me unconscious back onto the bus. They probably loaded me back on there and then dumped me back in my hotel room, tucked me into the bed to make sure that I wouldn't just be laying there fully clothed and whatever waking up and thinking, "What the heck happened to me in the night?"

David: Could you bring us to the next significant event that you remember happening after this initial traumatic experience?

Niara: The next major thing was being taken to the Moon. The next major thing that I was really dealing with.

David: So what I'd like to do, then, is let's go through that step by step.

Niara: Okay.

David: So again, you were working at Nellis most of the time?

Niara: Well, it's a funny thing because when you work the radar range, at least back then, when you were military working the radar range – I think they have civilians doing that job now – but you would work up there a week at a time, and then you would be down at Nellis for a week doing work around Nellis.

David: Okay.

Niara: Then you'd be back up another week. So every other week there was a different crew up there.

So I was a week on, a week off, a week on, a week off. And so this one week that I was up at the site, I got pulled out of bed in the middle of night, the usual routine.

David: Who pulled you out of bed? What did they look like?

Niara: That blond security guard, he was like my handler.

David: Okay.

Niara: He was usually always present for each one of the situations I found myself in.

David: And was he in a uniform, or how was he dressed?

Niara: He was wearing desert camo fatigues.

David: Okay.

Niara: Sometimes, I think, he wore other things, but that was mainly what he wore. And he had blond hair, very cold, blue eyes and a blond mustache.

So when I was talking about that ramp where you could look down at the craft, the way he took me, he took me to, like, an open garage door on the side of the mountain. And we went in from the ground level, where the craft was sitting parked.

And there was all these lights inside, and people were working around the craft. And there was this little ladder or stepladder that went up underneath the craft.

This security guard, he handed me these silver garments to put on. And I had to strip down and put them on without anything on at all. You had to wear them over naked skin.

And it had a strange faculty to it, where as soon as . . . It was shapeless, and then you put it on, and then it would kind of vacuum pack itself to your body.

And it had gloves and boots that would do the same thing. You'd put the boots on, and they'd be kind of suctioned on.

David: I've heard about this from other insiders.

Niara: Yeah.

David: And **Corey**, you're probably familiar with this kind of stuff, too.

Niara: Yeah. So that's what I put on. And so I had the boots. I didn't put the gloves on, but I had them with me.

And the blond security guard took me to the ladder to get onto the ship. And he said, "When you get on there, just go to the right and lay down. There's two other guys on there. You lay down between the other two guys that are laying on the floor."

David: And what did it look like on the inside?

Niara: Very basic, not a lot of features. There were some chairs around this central console.

David: Okay.

Niara: And there was a beam, a rather wide beam, right through the very center.

David: That's the waveguide for the propulsion system.

Niara: Yeah. And while I was laying on the floor in there, there was a reptilian that stepped out from behind that beam. And I looked at it, and all the breath just went out of my body. It was like, you know, I just couldn't believe what I was seeing.

David: What was the height of the being?

Niara: Very, very tall.

David: Okay.

Niara: 8 feet, at least.

David: And what was the surface of the skin? What did it look like? What colors?

Niara: Kind of an olive gray green. And it didn't stay out where I could see it very long. It kind of moved out from behind that pillar, and then it moved back behind it.

David: Did it have vertical slit pupils?

Niara: Yes.

David: And what were the color of the eyes?

Niara: Yellow.

David: Okay. Did it have sharp teeth?

Niara: Yeah.

David: Could you describe the hands and feet of this being?

Niara: Yeah. Claws.

David: Well, this is all extremely consistent with **Corey's** reports.

Niara: Uh-huh. Yeah.

Corey: It's very upsetting to recall an encounter with one of those beings.

Niara: Yeah.

David: Based on what she's saying . . . We've talked about the fact that the Royals are white, that there's a lower level that's a sable black color. The type that she's describing, where do you think they would fit in to the hierarchy that you're familiar with?

Corey: They're like the worker bees or the soldiers.

David: Okay. So you're lying there, and this being comes out, and you see it, and you have extreme fear.

Niara: Mhm. Yeah.

David: And then it just retreats after that?

Niara: Well, it's kind of like it was just kind of moving around, and it moved out of the way of the beam. And then it just stepped back where . . .

Corey: To a control panel, behind it?

Niara: Yeah. It may have been the pilot. Or maybe there was a Grey pilot, but I didn't see the pilot.

But some human beings came in before the craft took off, and they occupied the chairs. And then me

and the other two guys that were being shipped to the Moon were being shipped like human cargo. That's all I can say. That's how I felt. I felt like human cargo.

David: Were you strapped down to the floor?

Niara: No.

David: Okay.

Niara: No, they accomplish an awful lot with fear and intimidation.

Corey: Mhm. That's hard to make the average person understand, when you've been subjected to that kind of environment, how you can be so easily intimidated and do what you're told.

Niara: Yeah. Uh-huh.

David: What did it smell like inside the craft?

Niara: I think that I was smelling that creature. There was a musk to it.

David: Corey's used the same word.

Corey: Yeah. They're usually marked by their higher up who's controlling them with a musky spray.

Niara: Uh-huh. Yeah.

David: Wow!

Niara: Yeah. But when we did land, we were told to disembark the craft and to walk straight towards the nearest building. And we were not to look right, left, or up or down.

David: But you could breathe without a breathing apparatus.

Niara: I could breathe without a breathing apparatus. So either . . .

David: When you looked up, what did you see?

Niara: I wasn't really allowed to look up, but I did roll my eyes up to see if there was a dome up there because I thought, "I'm not wearing a spacesuit, and I'm on another planet, and I'm breathing."

So I wasn't sure what to think of that. Either there is atmosphere on the Moon, or I was under a dome.

David: Did anything look unusual as you were looking around you?

Niara: No.

Corey: Eyes on the boots. Ha.

Niara: Yeah. Yeah, that's really pretty much it. Eyes on the boots is a good thing. So I'm walking. I didn't have my eyes on my boots. I had my head straight in front of me like this.

David: Did it look more like just another military facility?

Niara: Yeah.

David: Was there a lot of conventional military looking stuff?

Niara: It's kind of like they took the same old ugly military buildings that they have on the Earth and put them on the Moon.

Corey: Exactly.

David: Ha, ha, ha.

Niara: Ha, ha.

Corey: Same doors.

Niara: Quonset huts and . . .

David: Right.

Niara: Yeah. All kinds of stuff. So I walked over there. I mean, in some ways, . . .

David: To this building?

Niara: . . . you could not even realize you were on the Moon because the buildings are so similar to the ones down on Earth.

David: And they told you to go to the nearest building?

Niara: It was kind of a largish building. And we went in there, and there was lots of rooms and hallways and stuff like that. And we just went to this one room.

David: Okay.

Niara: So the two things that I remember most about that particular trip to the Moon was the work that I did, where they had me operate some kind of electromagnetic excavation equipment because they were excavating different area of the Moon for more buildings.

And there was this thing where they had embedded two metal plates down into the ground. And then when they turned the electromagnetic equipment on, it was like those two plates were two poles of a magnet that are like poles. And they would repel, but very powerfully.

And these two plates would go apart and excavate this entire area as they're moving apart.

David: Crushing the rocks as they went?

Niara: Yeah. Uh-huh.

David: Wow!

Niara: Yeah. It was that strong of a magnetic field they were using. And you have to be kind of careful around that strong of a magnetic field because we've got minerals in our blood that could be pulled on.

David: Wow!

Niara: So there was that.

David: And they trained you on how to do this drilling, or this mining?

Niara: Yeah. Well, there wasn't that much to do. You just kind of operated the machinery, and you had to stand in your little thingy.

You know, so many people have been, shall we say, rubbed out because of the UFO field. I heard that 400 people alone were killed to cover up the Roswell incident.

David: Wow!

Niara: I don't think they're really at liberty to just dispose of people like that, especially people like me that they pluck from their normal, regular, everyday life and put in this situation.

So it's very important their mind control techniques, and the mind control trauma techniques, are fine-tuned to the point that you're not going to remember, at least not right away, what was done to you or where you were. But they want it to be covered up.

So they just keep doing these . . . It's a combination of trauma and drugs.

David: And **Corey**, you've said that the techniques work so well that only a small percentage of people actually remember anything, right?

Corey: Yeah. Yeah, just 3~5%.

David: Right.

Niara: So there was the excavation equipment.

David: Okay.

Niara: That was one thing. And then there was a lot of just manual labor, like stacking boxes and moving things from this shelf to that shelf, or just a lot of lift and haul kind of work.

The food was terrible. It was something I would call gruel and maybe dried bread and maybe a little water.

And then at night, I wasn't allowed to sleep. That was another part of the programming.

Corey: Sleep deprivation.

Niara: Sleep deprivation has been huge. Sleep deprivation in and of itself is a trigger for PTSD for me. And I've had a lot of sleep deprivation in my life.

David: Was there anything extraterrestrial or otherwise unconventional that you saw while you were there on this base?

Niara: When I was outside doing the excavation, I would catch glimpses of extraterrestrials. And the ones I remember were very, very tall and willowy. And they didn't look quite like traditional Greys. I'm not sure what species or race they were.

But it was one of them, that I found out in a later hypnosis session, that may have helped me get out of that situation.

David: Wow!

Niara: Yeah. Because they could see me energetically. And they looked at me, and they could see me energetically. And they just said, "They really shouldn't be doing this to this woman."

David: So you've been out there as a public figure. You've done conferences. I hope you're gonna get a lot more invitations because I think your story is very important.

Niara: Yeah. Uh-huh.

David: Do you think the Illuminati has a vulnerability? Do you think that they are invincible? Or do you think there is a way that this could be turned around in humanity's favor?

Niara: It could absolutely be turned around in humanity's favor because I know you know [**David**], and I know that you know [**Corey**] that everything is consciousness. Everything is consciousness.

And this physical stuff we see right here is underlied by an energy that makes this possible.

David: Right.

Niara: And that energy and those subatomic particles are influenced by thought, consciousness and intention.

And anything that we are looking at . . . Have you heard of the Georgia Guidestones, right?

David: Of course.

Niara: Okay. The Georgia Guidestones think we should have the population reduced to what, 500 million?

David: Yes.

Niara: Uh-huh. Okay. You know why they want to do that? Because they're scared to death. They are scared to death that 7 billion people could awaken and take the game away from them just by the power of consciousness.

And it doesn't even have to be all 7 billion. It just has to be a tipping point amount. And those are the people that I hope we're reaching out to today.

David: Do you have spiritual words of inspiration that you would like to share with those people who are awakening and who believe your story at this time?

Niara: Yeah. I would just say, realize that so much programming has been done on the human race for so many millennia to try to program our consciousness.

And this is the real Matrix, folks. It's trying to program our consciousness into a world that keeps them in control and keeps us subject to them. And it's all a lie because we are the ones with the real power.

The power of our consciousness is the real power on this planet, and we're all living under it right now. We are the ones fueling the machine, fueling the Matrix with the power of our programmed consciousness, programmed by the Illuminati, to create a version of reality where they are in control of us.

And all we have to realize is that that is a lie, and that we need to take our power back, and that we need to realize that through the power of our consciousness and intention . . . and we need to use the negativity in the world in a positive fashion.

That means when you look at something like a story I saw recently that the Great Barrier Reef is dead, so you can take that and you can turn it.

You can say, "Wow! There's a story that the Great Barrier Reef is dead. I'm going to go into my consciousness, and I'm going to see it thriving and alive and coming back into its full glory."

And use your power of your consciousness on that. So every time you see something out there that scares you, don't shy away from the fear. Just realize, "Yeah, that's a scary thing, and now I'm going to turn it completely 180 degrees, and I'm going to visualize something beautiful I want to see in its

place.”

And I would urge you also that if you're in a place where the weather will permit it, go outside and do this visualization. And take your shoes off, and put your feet on the Earth, because the Earth herself wants this process of human evolution to occur.

And just like when we saw people touching things in “Avatar” in the ground, and the plants would light up, that happens here, too.

We don't see it visibly, but it happens here, too. Okay? We are connected with our Earth mother, just like the Native Americans have taught down through the ages. So get her onboard.

And remember where it said, Jesus said, “Wherever three or more are gathered in my name”? Try to get a couple of friends to go out with you barefoot on the Earth. All hold hands and pick that thing that you want to visualize as healed and whole and complete. And we can change this planet, and we can take it back, and we can make it a garden again.

I believe that with every fiber of my being.

Corey: So do I.

David: How does it feel, **Niara**, to have folks like **Corey** and **William Tompkins** coming forward so remarkably validating your testimony?

Niara: It's a relief. It's a relief because you put out a story like mine, and you know that at least half the people that read the book are gonna think you're wonkers. And whatever.

But I don't have any investment in people believing the book. I just want people to have an idea of the kinds of things that are going on. And I did tons of research. And I put tons of research links in the book because I wanted people to realize that I'm just not some lone voice in the wilderness coming out with this.

I'm part of a whole culture and a whole community of people that are coming out and saying that this is real and this is happening. And if it doesn't stop, we are all at risk.

David: I know from hearing your story that there's going to be a lot more validation.

Niara: There is a lot more.

David: And I applaud you for your bravery and your courage in coming out today . . .

Niara: Thank you.

David: . . . and sharing this with the world. It's a very personal thing for you. And I just love you, and I want you to know that. And I'm here with you as we go through this together.

Niara: Thank you.

David: Thank you.

Niara: Thank you both.

David: And I want to thank you folks at home for your support for her and for this effort that we're making to try to bring peace to this planet and to all beings living on it.

So we'll see you next time. This is "[Cosmic Disclosure](#)". I'm [David Wilcock](#) here with **Corey Goode** and **Niara** Isley. Thanks for watching.

[Cosmic Disclosure: Viewer Questions 8: Protocols and Loopholes](#)

Season 7, Episode 26

[David Wilcock](#): Welcome to "[Cosmic Disclosure](#)". I'm your host, [David Wilcock](#). I'm here with **Corey Goode**, and in this episode, once again, we are taking your questions that you've written in to us so that we can have a two-way dialogue here and engage in the stuff that matters to you the most.

So, **Corey**, welcome back to the program.

Corey Goode: Thank you.

David: All right. So the first question we have here is:

“What was the vetting process that Gaia led you through leading to you being considered a trustworthy and reliable whistleblower with an entire show built around your information?”

Corey: Well, I guess after I made it through your vetting process, I was introduced to the team up here, names that a lot of the people in this community would recognize. I didn't at the time. I didn't know who they were.

My first encounter was I was brought into a room – I did not expect to be questioned at the time – and two or three people, I believe it was three people, came and sat around the desk, around the table, and just started pelting me with questions.

And I think I did about, all in all, about 20 hours worth of answering questions.

David: So what was the nature of the questions that you were asked?

Corey: Very in-depth, very intricate questions, that the same questions would then be snuck back in, but in a different way. It was a . . . They were being very thorough and trying to be tricky.

At first, the people sitting across the table, they were kind of like, this. [*Corey shows an expression of doubt and skepticism on his face.*]

And as we got through the process, the looks on their faces changed obviously because I was invited to begin doing episodes.

David: So **Corey**, you mentioned the vetting process that started with me, and I think that's an important point. What a lot of people don't realize if you watch this show is that I had people coming forward, like Henry Deacon, as an example, who barely ever said anything publicly.

Another one would be this guy Daniel, who allegedly worked on the so-called Montauk Project. Another one is the guy Jacob, who I've dedicated an entire chapter to in my new book.

The bottom line is that I was holding on to a very interesting, world-transforming story about a secret space program with literally thousands of individual pieces of information that I had never gone public with so that I would know if somebody was real when they came along.

And you remember that when you and I started talking, especially within the first, I'd say, two or three months, every time you and I spoke you were finishing my sentences.

Corey: Right.

David: You knew things that I already knew and had heard from other people. And I think what was really bizarre for me was that, despite how much I thought I knew, it was like having a flashlight that I could only look through the keyhole of a door with.

And then when I talked to you, it's like somebody opened up the door.

And you had said to me before how interesting it was that a lot of these people that I'd had briefings from before would kind of walk up to a line.

Corey: Yeah. That's one of the . . .

David: Could you describe a little more what that is?

Corey: Right. And that's one of the reasons I did come forward – originally I wanted to come forward anonymously – was that I was seeing a lot of these people, I heard what they were saying, I knew they were legitimate, but they were walking right up to the line without crossing it. They never crossed the line.

David: What were some of the things that would have been crossing the line?

Corey: Well, some of them that had been to Mars could have given a lot more detail. They could have told more about the Mars base that they went, about the slave labor, a lot of different . . . There are a lot of different details that they could have easily have shared.

David: Why do you think there would be people that would say some things but then withhold so much?

Corey: Well, they step over that line, there's ramifications. So they were sharing what they could, what they felt they could, and stay safe.

David: How do you feel that the case of **William Tompkins** has affected what you've talked about on this show? Have you had any personal discussion with him, and how much does he know about what you know?

Corey: Yes, we've been working together recently, and I've had a number of discussions with him. And it's very apparent that the information that I was looking at on the smart-glass pad was information that had come from his briefings when he was speaking with the German double agents.

And there were a lot of little details that we've been talking about back and forth to each other that I've seen a light in his eyes several times on a few subjects.

David: We also incidentally had **Pete** Peterson tell me recently that the conclusion of the United States government now is that you were in contact with real extraterrestrials when this thing started, that that contact that you have experienced is, in fact, genuine.

So that is significant, because here is a real insider who has said that the collective view on the inside now is that your information is authentic.

Corey: Yeah. Well, they're watching me close enough, they should know.

David: All right. Well, let's have another question. This is kind of interesting and dodgily worded, but we'll take it.

“Why is the Cabal allowing you to come forward with your story and intel?”

Corey: It's not that they're allowing me to. There is kind of a stalemate between the Alliance and the Cabal. The Alliance has their assets in play and so does the Cabal.

What seems to be occurring here is that I'm probably getting rolled up in this Navy disclosure that's occurring through **Tompkins** to begin with.

So he was given the green light to go forward with this information that is almost exactly the same as what I've been sharing. So there might be some sort of claws that has kept, I guess, the powers that hopefully will be were soon off my doorstep.

But they've definitely made themselves known. You know, the helicopter flyovers. Out in the backyard with my son I've got green laser dots on my chest. They make themselves known.

David: Do you think that people have been conditioned through various Hollywood movies to believe that the so-called “Big Brother” is this all-powerful, all-seeing eye, and that anybody real would never be able to say anything without being immediately whacked? Do you think that's a social conditioning they gave us?

Corey: It is. And, I mean, there are plenty of people in this field that even believe that it's impossible to destroy the Cabal.

David: What do you think about movies like “Iron Man 3” and “Captain America: The Winter Soldier”, where you have military assistance in the movie, you got a \$100-plus million budget, and the films are very clearly exposing the Cabal? Nobody could possibly deny that.

Corey: There's definitely been Alliance money and agendas poured in to Hollywood recently to expose different aspects of the Cabal. That is a good sign, since Hollywood has been completely controlled by what we're calling the Cabal since its inception.

David: I'm going to hit you with another one here.

Corey: All right.

David: Whoa! “Is there a way we could offer a type of forgiveness to the Cabal/Alliance in exchange for a Full Disclosure?”

Corey: Um. I think things like that have been floated around, but on the Alliance side, how many people can you get to agree to remove the ramifications of what the Cabal has done over the last 100 years minimum?

David: Right.

Corey: These people want retribution. You know, they're not angelic people. They want payback for all of the crimes against humanity that have occurred.

David: When you say “these people”, you mean Alliance?

Corey: The Alliance, yeah.

David: Yeah. I also think, and let me ask what you feel about this, that the people who are following this in our community have had a lot of time to learn about the truth. Whereas what you've described seems to be a rather sudden exposure of a lot of information that's very disparaging.

And how do you think . . . Or what is the modeling from the Alliance of what happens when all that disparaging information comes out at once?

Corey: You know, I have not seen any type of plan for a post-disclosure world. That's one of the things that I've been working with other people to come up – psychiatrists – to come up with a response plan.

If we get Full Disclosure, there's going to be a lot of people out there that, like you've said before, that won't be able to get out of bed or feed themselves, that are going to need help.

David: Right.

Corey: I haven't seen a plan from anyone yet for a post-disclosure world.

David: *“Are there protocols in place to counter information leaks and whistleblowers? How extensive is the use of disinformation, cover stories, etc., to try to maintain plausible deniability and secrecy?”*

Corey: Well, yeah, they do use misdirects a lot to find out where leaks are coming from. You will compartmentalize your people, which is usually already done in the military or in programs.

Then you'll give them slightly different versions of information to find out which compartment you need to focus on before you focus on the individual.

David: Hm.

Corey: So, yes, a lot of misdirect is used, yeah. They will lie to you, and they have no problem with it to try to trick you into giving yourself up as a leaker.

The go-to method of countering the leaks is to attack the leaker, to use character assassination, or to dig up something from their past. So that's the number-one way they go after people that are more in the public sector.

If you're in the programs, and you're trying to leak something, unsanctioned leaks, then you could very easily disappear.

David: *“If the Secret Space Program and other Cabal groups have anti-aging or healing technologies, then why do they not appear to be used by folks like George Bush Sr., Henry Kissinger, and other high-level elderly members of the Cabal?”*

Corey: Well, a lot of the people that we think are high levels . . . high-level members of the Cabal, really aren't. The highest-level people are people . . . we don't know their names. We don't know who they are. They've stayed off the map.

So they are taking advantage of some of these technologies, but they use these technologies within these Cabal groups to control the people below them. You know, they always act . . . It's like a carrot to dangle in front of them.

“If you do this, when you reach a certain point, we'll put you back to a certain age and then insert you back into society rich and let you do what you want to do.”

David: I've heard this, and I want to get your comment on this, that some of these people at that level that was in the question might be offered something more akin to a soul transfer, where their awareness could somehow, through an advanced technology, be downloaded into what appears to be a completely separate being.

Corey: There are different facets of these Cabal groups. Some of them are AI prophets. They want to be uploaded into some sort of a database.

There is a technology that is a soul transfer technology that uses electromagnetic fields to push a person's soul from one body into another that is compatible, that's been genetically designed to be compatible with their energy like their old body was.

And then there's the groups that will . . . they'll reach a certain age, then their deaths will be faked. They didn't really die. They'll be taken, and then they'll be regressed back. And a few years later, you may see someone and be like, “Wow! That looks like Henry Kissinger when he was 28 years old.”

David: Hm.

Corey: But other than that, there's no way of knowing what happened to him.

David: Is there a cloning technology? Could they clone out somebody and make a younger version of them?

Corey: Definitely. That was the version you were talking about where they push you into another body with a soul transfer. You have to have a cloned, genetically engineered body that's going to match your frequency so . . .

David: Oh, it has to be a clone of your own body?

Corey: Yes, or they can . . . They do create other avatar bodies that are . . . but they have to be genetically programmed to match your frequency of your DNA, and all that.

David: Hmm. I have had other insiders tell me that the typical clone doesn't live much more than about two years.

Corey: Well, it has to be genetic . . . perfectly genetically engineered to you. To live in it long term, it has to be a designer body that will match your . . . the frequency.

David: *“What forms . . .” this kind of lends right into what we were just talking about. “What forms of human enhancement technology already exist? Examples might be growing taller, growing more muscle, increase in your IQ, increase in your ability to remember.”*

Corey: Once we'd started to receive this technology from non-terrestrials on genetic programming and manipulation of the human body, it's become child's play.

The human body is very easy to change and manipulate with certain technologies. They can trick the body in certain temporal fields to accelerate or reverse the age of the cells. So they can do all kinds of stuff.

David: I want to throw something at you, a wild card, that I just heard from another insider who has connections to the space program who has not come forward yet. And he just kind of randomly threw this out.

We were talking a couple of weeks ago that he was aware of a particular group of humans that were being grown to be of a very large size for certain work out in space, but the speed that they were being

grown was too fast, that they're basically like worker drones.

And that as a result of how fast they're being grown that their faces are kind of hideously disfigured with keloid-type of scars.

And he said that had something to do with if you try to push this genetic material to grow too fast, then you get these ugly . . .

Corey: Hormonal things.

David: . . . anomalies that occur. Do you have any comment on that?

Corey: Yeah, yeah. There's some of the . . . kind of like super-soldier-type programs they had, where they were growing these humans, but playing around with their hormones in a way to make them gargantuan, to make their bones bigger.

But their foreheads would look real weird around their eye socket. Their jaws would look very caveman-ish or weird from the process.

David: Hmm.

Corey: Yeah, that's something I'd heard.

David: Interesting, yeah. Okay. So just to clarify this question then, they do have the ability to do something like boost somebody's IQ as well?

Corey: Yes, they can enhance your IQ. They can enhance your intuitive abilities through genetic manipulation, gene therapy.

David: Okay, interesting. I hope this question is answered in the affirmative, but we don't really know, I guess.

“Will the public be able to travel freely through our own Solar System and beyond in the next 70 years?”

Corey: I don't see this technology being readily available to everybody immediately. I think there's going to be a process. They're going to have to develop it on a large scale. People are going to have to

be acclimated to using it.

I think it'll be a while before the average person is able to take a cruise to Jupiter.

David: Right. Do you think that there could be some sort of accepted protocol for portal travel rather than craft travel, where people could get jobs and portal to certain locations to and from Earth as a part of their job?

Corey: People like diplomats and stuff like that, not your average person – not in the beginning. It'll be a while.

David: Okay, next question. “If replicators work on the principle of converting energy to matter, does that mean there is also a reverse of this technology where you could dispose of waste by turning matter back into energy?”

Corey: Yes. Yes.

David: Ha, ha.

Corey: Yeah, yeah. They have . . . Yeah, they have the ability to reverse the process.

David: Okay. What's an example of you seeing this happen? Have you ever seen it been used?

Corey: I haven't watched it be used, but I knew that they had the technology and that it was used.

David: Does the energy get stored in some kind of battery, or where does it . . . where does it go?

Corey: Well, they can also use that for site-to-site transport of different materials and stuff. So, I mean, yeah, that's not something I have a whole lot of details on.

David: Okay. “*Is there any way for us to protect ourselves from scalar waves and other types of mind control technology?*”

Corey: I don't know of a really good way, short of living in a SCIF room or a Faraday cage, to protect yourself from these things. Unfortunately, I don't.

David: All right. Let me throw something at you. I just had an insider the other day, who swears by this, talk to me about this. He always carries an empty bottle, like a plastic water bottle, in his backpack

or something.

And he claims that if a scalar beam is used against you, that you'll hear it suddenly crack a little bit. Like it'll pop. There's something about the air pressure changes. Have you ever heard of that?

Corey: Yeah, that can happen in certain frequency. Yeah, that can happen, but . . .

David: And he said that if that happens, you just move to a different location, because this technology apparently requires you to be in one spot as it's working. And if you move even a little bit, it apparently reduces the effectiveness.

Corey: Yeah, that's true.

David: Okay. Well, **Corey**, let me ask you this, because I've had a lot of discussions with **Pete** as well on this, and he claims that he was a mind control specialist for a while, several years.

He said to me that certain people have what he calls alien DNA, and that with that DNA comes a much greater resilience to these types of technologies. Have you ever heard anything like that?

Corey: Not that it was alien DNA, but that different individuals have the ability to resist the technologies a lot more than others.

David: Now, another interesting thing that he said was that he developed something called a flicker frequency generator. And that the basic idea is that if you're . . . the speed that your brain is running is above a certain flicker frequency, a certain refresh rate, that these technologies become a lot less effective, and so it would stimulate people's frequency to go higher.

Corey: Yeah.

David: Have you heard anything about a higher frequency possibly being a good countermeasure?

Corey: Well, there's also . . . In the programs, yeah, you're going to have countermeasures. But the average citizen out there, like the person asking the question, they're not going to have countermeasures.

There's pharmaceuticals people can take that affect their body in a way that makes them less susceptible to these things.

But for the average citizen out there, you can't just put foil around your head and hope it's going to work. I mean, there's nothing really they can do.

David: Well, I just want to raise the possibility, from some of the discussions I've had with **Pete**, that if you have, according to his research, if you have a meditative peaceful focus, that that actually raises your flicker frequency and makes you less susceptible.

Corey: Right.

David: Do you think that's possible?

Corey: Yeah, more positive people, people that are definitely unplugged, are less susceptible.

David: Okay. So if people practice meditation, forgiveness, love, they're less likely to be affected by this kind of stuff.

Corey: Ah, it'd be mitigated.

David: Okay, fair enough.

“The Mohammad Accords state that the ETs are not allowed to interfere in the development of humankind. Have the Draco and the Blue Avians broken these accords by taking the steps they've taken?”

Corey: Well, first of all, the Mohammad Accords really don't have anything to do with Mohammad, other than they occurred around the time that he was here on Earth.

David: Right.

Corey: The Reptilians and the Blue Avians, I guess, they were saying that violated this treaty? They have not . . .

David: They're wondering if the noninterference clause has been violated by them appearing as they have.

Corey: Well, they haven't been appearing to the masses.

David: Right.

Corey: If they would appear to the masses or small groups of people, then, yeah, that would definitely be infringing.

David: How is the work that they are doing falling into the guidelines of this treaty then?

Corey: The positive beings stick to these laws very closely, but they know how to skirt them very well. And I'm sure they're working just barely within the boundaries of the Accords.

David: What would be an example of the Draco trying to get as close to the edge as they can without walking over it?

Corey: Well, the Draco, they've been known to appear in front of small groups that have kind of summoned them, but they're not going to appear in front of a large group of people or people with cameras or anything like that. That's against the Accords.

David: *“Is there a program to interbreed humans with extraterrestrials and create hybrids? If so, why does this exist, and have you seen any of these children?”*

Corey: There are, as I've stated before, 22 different programs that are both genetic and spiritual. Within these programs, there are multiple different subprograms where they are splicing DNA with other beings as a part of this greater experiment.

And some of these beings are . . . they use them.

Basically, a billion years ago there was an alien group that we're talking about. We're seeing these weird hybrids that ended up being us, that we were then transported to this planet.

There's a lot of that going on – a lot of genetic farming going on. To try to pin it . . . which program is going on with which group, is very difficult because there are multiple hybridization programs going on.

David: Another question that comes up from an insider that I've been talking to recently: *“Do you think that because Earth is this genetic cornucopia where apparently many more types of genetics can*

survive on this planet due to its complex frequencies, do you think that there could be future programs in which many other types of life on Earth are accelerated to the point where they become human-like hominid life and are then seeded throughout the galaxy at various points?"

Corey: Yes, that's part of the 22 programs.

David: Oh, really?

Corey: Yes, definitely.

David: Do you think that may account for things like squid beings, dolphin beings, insect beings, this kind of stuff?

Corey: These different genetic programs, they work in concert with what is occurring in the region of their experiment, cosmic energy-wise. We're about to have these energy fluctuations coming in that are going to make massive changes. They're working in concert with that.

David: *"Do you have any advice on how we could identify extraterrestrials and hybrids who have integrated amongst us already?"*

Corey: It depends on what stage they're in of integration. A lot of times they will bring these beings down, even have a human handler to help them acclimate.

David: When you say they will bring these beings down, who are they?

Corey: The beings that designed them, that created the hybrids.

David: Okay.

Corey: They will bring them down, set them up in a situation to where they'll have an apartment, maybe a job. And they'll have a human, who is a contactee, help them, assist them, in acclimating to human life.

David: But obviously what you're describing now would have to be a being that's almost indistinguishable from any other human on Earth.

Corey: Right. Right.

David: Okay.

Corey: You're not going to see the hybrids walking around that are . . . that look different.

David: Some people might be very afraid of that information. So let's just talk about this a little more.

First of all, if such a being is put here, do they pose any unusual threat to us above and beyond a typical human being on Earth?

Corey: No. They're just learning how to socialize, how to fit in.

David: They don't have any unusual characteristics that would allow them to have a weapon capability or something that would make them very dangerous to human life?

Corey: Not that I know of.

David: Okay. How widespread to you think this type of immigration program is?

Corey: I mean, it goes on. I don't have any numbers. But it was something that was going on and that we knew about during the intruder, intercept and interrogation programs.

There would sometimes be groups that would come in and try to plant people like that without the proper clearance or that weren't working with the correct groups.

David: *"If the various terrestrials and ETs are different density or vibrational beings, how are they able to meet and communicate with each other?"*

Corey: This gets back to the people getting densities and dimensions mixed up. The way I've described it is, what would you describe a bacteria as, what density?

David: In Law of One terms, that's second density.

Corey: Second density. What about a worm?

David: Second density.

Corey: Second density. Can you touch a worm?

David: Absolutely.

Corey: Can a virus interact with you?

David: Yeah.

Corey: Yeah. So it's not like if something is fourth density, all of a sudden you're reaching through it like a ghost.

David: Right.

Corey: That's just not my experience.

David: So a higher-density being could leave behind a corpse that would rot?

Corey: Yeah.

David: Okay. *“Have you personally met any extraterrestrials with feline-human characteristics?”*

Corey: I did not meet one, but I saw one that had recently been killed. There was a capture or kill order out on this feline-type non-terrestrial. They were able to appear and disappear at will.

They had trapped this one somehow in some sort of a net, an electronic or electrical net that killed it.

When I saw it, it was . . . the way it was laying over it was crispy. It did not die in a pleasant way.

David: Wow! So getting to this question again about the densities, this is a being that did leave behind a body, but also could dematerialize.

Corey: Right. But using what technology, I don't know . . . if it was technology or if it was an ability that they had.

David: That leads to another obvious question implied by what they wrote here, which would be, if James Cameron's movie “Avatar”, as **Pete** Peterson has testified, has multiple examples of accurate hardware that's already being used in various space programs and the mining seems to be accurate, what about the people in “Avatar” with this feline characteristic?

Do you think there's any truth to that?

Corey: I think that they did base that off of reports of . . . There are a number of creatures that have feline looks, but there's one that people in this community tend to talk about a lot, and that happens to be one of the ones they have a capture or kill order out on.

David: Is the skin color accurate – the blue?

Corey: It was more of almost purple.

David: Uh! Really!

Corey: Yeah. Lavender, I guess.

David: Interesting. All right. Well, that's all the time we have for questions for this episode. This is **David Wilcock** and **Corey Goode** bringing you “[Cosmic Disclosure](#)”. And we thank you for watching.

Cosmic Disclosure: The Shadow Cold War

Season 7, Episode 27

David Wilcock: All right. Welcome back to “[Cosmic Disclosure](#)”. I'm your host, **David Wilcock**. I'm here with **Corey Goode**. And in this episode, we're going to get into the highly sought after updates that will bring us current with what **Corey** has heard at the time of this taping.

Before we do that, we're going to have a little footage for you from one of our brand new shows here on Gaia. This show is called “Erich von Daniken, Beyond the Legend”.

So without further ado, let's take a look at this footage, and then **Corey** and I will have a little discussion about it. Here we go.

* * * * *

COMING SOON ON GAIA

Erich von Daniken: Recall the pyramids in Guatemala, Central America.

There again, under the main pyramid, they found a big sarcophagus where they believed, finally, we find the founder of the City Tikal, the one who created the city.



Coming Soon on Gaia





But inside they found quicksilver.



Quicksilver is, again, one of the components of the fuel of the vimanas in ancient India.

I say the ancient Indians . . . We have translations of the fuel, the composition of the fuel, what was together. And one of the components was mica.



Now, in Teotihuacan, in this city outside of Mexico City, there is a mica chamber completely isolated with mica.



It was, for a long time, not open for the tourists.



After I had published it in my book, now it's open for the public. They cannot hide it anymore.



We have no reason today . . . Why is the whole chamber completely isolated with mica?

* * * * *

David: Well, this is interesting because this idea of what he's calling quicksilver actually being mercury, of course, shows up in the propulsion systems of the German Bell craft.

So do you have any idea why we might see a similar material, or the same material, appearing in an ancient pyramid as became this very useful propulsion medium for modern space travel?

Corey Goode: Well, you know, the German craft were reverse-engineered from craft that were given to them.

And those craft had the mercury engines as well, the mercury fueling the electromagnetic field in their engines. So that's been in use for millennia, if not before humans were on Earth.

David: So you think that it's possible that there could be some type of anti-gravity effect generated in the pyramid, or some type of energetic from the mercury?

Corey: It's more of a storage place for the fuel and the mica. They were storing it for future use.

David: When von Daniken is talking about the idea that a room made out of mica could shield high temperatures and electromagnetic fields and this kind of thing, why do you think they might have built a room like that?

It would obviously take great trouble to go to such an extent to put mica inside the pyramid like that. Why do you think that might have happened?

Corey: Maybe they had something inside that room that they were trying to shield the walls of the pyramid from so they wouldn't crack, . . .

David: Hm.

Corey: . . . some sort of an electric generator of some sort – maybe one that's of a different technology that we don't know about.

David: You've said in some of the previous updates we had that even recently, the Alliance has been discovering new chambers with technology in them in various ancient stone works around the world. What is the nature of what they're finding?

Corey: Well, not only are they finding things in the walls of some of these ancient structures, but they're finding much older structures underneath.

David: Hm.

Corey: That these, what we think are ancient structures, they're built over much, much [more] ancient structures, ones that most likely go back to the Pre-Adamite time period.

David: Hm. And are there any specifics about what type of gadgets are being found? It sounded to me like you were saying that they are finding highly advanced gadgets that would not be stone but would be something that we would clearly identify as a very high technological piece of equipment.

Corey: Yes, and these appear to be after whatever great cataclysm that occurred in ancient times where the Pre-Adamites lost their major foothold on the Earth.

It is pretty much postulated that they've taken these trinkets and hid them in this manner for a future time.

David: So be on the lookout for this new show here on Gaia, because von Daniken, of course, the author of "Chariots of the Gods", is a legend in this field, really kind of started the whole ancient astronaut theory in the first place.

You have Velikovsky before him, but "Chariots of the Gods" was a really amazing book that was a very, very major bestseller in the 1970s.

And so we all owe a great debt of gratitude to von Daniken for bringing this information to our public awareness.

All right, well, let's get into the updates now. And we have a nice outline here, so I want to make sure that we get through everything. There's a lot to talk about.

The first thing, **Corey**, that we have in our outline is something regarding your contact in the SSP, Military-Industrial Complex version, Sigmund.

And what ended up happening with Sigmund from where we last were speaking?

Corey: Well, the last time I did an episode on these updates, afterwards, we had a get-together at the bed and breakfast I was at. And . . .

David: You and Sigmund did?

Corey: No. Me and you and a few other people.

David: Okay.

Corey: We were getting together for a little bit of a celebration.

David: Right. You're talking about here in Boulder.

Corey: Right.

David: Yeah.

Corey: After everyone had left, and I went to bed, a dual-cab pickup started driving up to my bed and breakfast, and the headlights were shining in the window.

I thought that it was somebody returning back from the party, because it wasn't that long after.

While I was sitting there, I saw three figures walking up to the door. The bed and breakfast I was staying in, the door wasn't locking to my bedroom.

David: Oh!

Corey: It was kind of a glass door that opened. And I saw three figures walking up. I'm sitting up in bed. I still had a freshly broken foot from my trip to Hawaii and feeling very vulnerable.

He just knocked on the door and opened it at the same time, coming on in as if he knew it was unlocked and walked in.

David: Hm.

Corey: And immediately, I was . . . It freaked me out.

David: You didn't know who it was at first?

Corey: I didn't know. I wasn't expecting him. I didn't know who it was, and they just came walking in.

David: Wow!

Corey: After I settled down, and we started to talk . . . While this was going on, the two airmen I called Tweedledee and Tweedledum were . . . One of them walked up and stood on the balcony and was walking, and the other one stood sentry outside the back door.

He asked me how the taping went, if, indeed, I had shared the information about the R&D facilities and the secret spaceport down in Antarctica.

And I told him, “Yeah, I shared the information – how he shared it with me,” and he said, “Good, but that's going to be my ass.”

David: And this is because, as you said before, they're violating some kind of international treaty by having military presence?

Corey: Weapons development is not suppose to occur down there.

David: And just to be clear, when you say “spaceport”, are you talking portals, or are you talking spaceships, or both?

Corey: Well, all the information from the last update - the spaceport that we received from the Nazis later on, and the R&D facilities were ones that we built during the '60s during Project Iceworm.

David: So he thinks it's going to be his ass but he doesn't care?

Corey: Right. He said this information needs to get out.

David: Hm.

Corey: He further warned me that once that information breaks, that I better get ready, and all the people in my orbit should get ready, because all hell was going to break loose, which actually has occurred.

David: And how would you describe “all hell breaking loose”?

Corey: Well, Sigmund disappeared. I was picked up by Tweedledee and Tweedledum. They were very concerned, and they wanted to know if I had heard from him.

And when I said, “No”, they looked even more concerned, and they let me know that he was taken from his home somewhere in Virginia. His family was freaking out that no one knew where he was.

Strangely enough, I talked to Linda Moulton Howe on the phone this morning, and she told me that during the same time period, about three and a half, four weeks ago, her major insider in the Secret Space Program disappeared.

David: Wow!

Corey: So we have that aspect going on, people disappearing, and we also have these large coordinated disinfo attacks and character assassination attempts that have been going on against anyone working with me.

David: Hm. Was there anything else that you discussed with Sigmund during this meeting before he vanished?

Corey: Yes. He wanted me to dial back talking about the Blue Avians or Inner Earth groups, that he wanted me to only talk about the nuts and bolts experiences I had in the Secret Space Program.

David: Hm.

Corey: He said that the people that I had been giving the briefings to, they just could not follow it. They could not track it. He said that if I would pull back that narrative, that he would begin to set up these briefings again.

David: Hm.

Corey: I told him that I was not going to back off talking about the Blue Avians and what was going on.

David: It seems to me, **Corey**, that if whatever Cabal group or groups is responsible for making people disappear and doing what are almost absurdly exaggerated lies on an epic scale about you and me and others online, this doesn't look like a group that's winning. This looks like desperation to me.

Corey: Right. It's what we've been seeing for a while. The intelligence community has come up with this new “fake news” model, and it's taking off like wildfire in mainstream media. But in the alternative news area they're really starting to implement that same model and just put out the biggest lies they can and present them as truth and see what sticks.

David: Do you think that all of these actions are happening because we are closer than ever to some kind of disclosure event?

Corey: We're close to some major event. All the talk I've been hearing in the background from the military groups about what's going on, sounds like everybody is very nervous. The Alliance is nervous to see how things will turn out, but the Cabal groups, they're nervous to a point to where they're beginning to make some serious mistakes.

David: So the next part of our outline here is another interesting area. And let me start this off with a question, and that is, what was it like for you meeting **William Tompkins**, who's 94 years old and goes all the way back to actual World War II briefings about the space program to the highest level American generals and military officials?

Corey: It was amazing. Recently, **William Tompkins**, Dr. **Bob Wood**, Dr. **Michael Salla** and myself decided to write a book called “A Case for the Secret Space Program”.

When we met in San Diego for the first time, of course, being a character, **Tompkins** walked up and acted like he didn't know who I was to mess with me.

Once we sat down and really started to record and speak, the amount of correlations that we had were amazing. I mean, it was very obvious from speaking with him that most of the smart-glass pad information I read about the World War II era had come through his briefings.

David: Wow!

Corey: And there were a number of other things. Like I talked about the pirate ship, and his cousin had the same thing – a pirate ship coming to pick him up. We had some . . .

David: I don't understand what you mean by “pirate ship”.

Corey: Well, when you're a kid, we would have memories of a pirate ship flying through the sky, like Peter Pan, and coming to pick us up. But it was really a masked UFO.

David: I see.

Corey: And so we would have a memory of being picked up by something other than a spaceship.

David: What was the most unexpected correlation between your data set and his that maybe you had no idea would have happened?

Corey: Well, the thing that's kind of come up the most is this . . . some sort of interaction going on with this Nordic group.

David: Hm.

Corey: My inner circle, this team that I've been building, all of them seem to have some sort of history with this Nordic race. One of the people on my team told me, when we were discussing memories we had as children about these Nordic races, told me about a memory that was similar to mine, but almost exactly like one of my good friends from 20 years ago.

It was a dream to where he was a kid, and he was around a bunch of other kids. They were playing these three-dimensional holographic games, like puzzle games, and when he was able to solve it, they pulled him aside and started showing him star charts and planets, saying, “Is this your home? Is this your home?”

And it was the exact same memory that my other friend had shared, which was similar to mine. I didn't have as much detailed memory, but I had a memory of a Nordic standing next to me, studying me very closely, showing me images of star systems and planets, asking me, “Is this your home? Is this your home?”

David: Wow!

Corey: As if they're trying to find out where you're from.

David: Was there anything about his knowledge of Reptilians that surprised you or otherwise was unexpected?

Corey: No, it was just a lot of confirming each other's information when we were sitting there having a conversation. It was pretty exciting.

David: It's certainly interesting when you read **Tompkins'** book, "Selected By Extraterrestrials", to really get the sense that he's just being telepathically steered, almost by remote control, to build these craft designs that became the ship, apparently, that you were in for Solar Warden.

The Nordics really seemed to have been doing an awful lot, but yet they work through somebody like **Tompkins** to get these initiatives met. And yet, they seem to also be actual secretaries working at NASA and other agencies.

So what kind of conversations did you guys have about that Nordic influence?

Corey: Well, we discussed the Nordic influence that was going on right now. And I'm not going to go into a lot of details, but what you described about being influenced or giving information, synchronicities occurring, being guided from an unseen force, which, it's all pointing to the Nordics.

David: Hm.

Corey: Point so much to the Nordics that when I had my next meeting with Ka'Areë, I said I finally was going to hit her with these questions, because too much was popping up about this group.

David: Hm.

Corey: The first opportunity I had to ask her about it, I asked her who this Nordic race was.

David: What Nordic race?

Corey: This Nordic race that had been . . . that we're talking about.

David: Working with **Tompkins**?

Corey: Well, **Tompkins** and us.

David: Right.

Corey: I asked her about this Nordic race. I said, is this Nordic race the same blonde, Nordic-looking people that I saw in that Inner Earth meeting?

And she said, “No, these are brothers and sisters of the Confederation.” They work quietly in the background, they guide humanity, they give humanity insight and ideas, but they usually do not interact with us directly.

She said that they have been interacting with us and guiding us for thousands of years – a very long time.

David: Do you know whether they're from Inner Earth?

Corey: They're not. When I was . . . I was pushing that. I kept going back and pushing that. And she hadn't seen me like this before. I'm normally . . . was more kind of docile and playing along, but I was asking for answers.

She finally confirmed for me that the Anshar are actually people from the future, from after we've gone through all of these fourth-density changes, somewhere in the future the Anshar had what we would consider like a Mandela Effect thing occurring in their society. Their people . . .

David: Could you be a little more specific about what you mean by that? What was the Mandela Effect that was happening in their society?

Corey: I don't know.

David: Okay.

Corey: They were having . . .

David: The Mandela Effect means that there are bifurcating timelines, that things don't line up. Somebody remembers something, but it's not really there.

Corey: Right.

David: Or it's a little bit different.

Corey: Right.

David: So they start having time anomalies like this, . . .

Corey: Right.

David: . . . like their history books are not the same as what they remember – this kind of stuff?

Corey: I wasn't given any examples, . . .

David: Okay.

Corey: . . . but they had their own Mandela Effects occurring that caused them to look back and see about when this was, this bifurcation, was occurring, and they decided to send a group back 17 million years, around . . . just before the time that the temporal anomaly was occurring, to have this group be stewards of their timeline.

There's a possibility if they don't steward the timeline properly, that they could cease to exist.

David: How does somebody travel 17 million years back in time? Let's start with that.

Corey: The same way they travel 17 light years in space.

David: Hm.

Corey: I've explained in the past – time and space – if you can travel through vast distances in space with short periods of time, you're time traveling. And these beings can travel through time as easily as they can travel through space. It's happenstance. Either one is just as easy for them to do.

David: Well, we seem to have a similar analogy in the scholarship on the so-called Montauk Project, where apparently there was this hopscotching timeline between 1943, 1963, 1983, where the Philadelphia Experiment occurs in '43, but then by '83, there's some sort of really big time anomaly that overlaps in the Montauk Project, like a wound in time, a rift.

And we've often heard other insiders saying that when you have a rift, that really negative beings can get in through that.

Do you have any idea as to whether what they experienced in their future was a rift of this sort, where maladaptive entities could get in and they had to fix it, or . . . ?

Corey: I didn't receive any of those details. I kept circling the conversation around to push her for more information about this Nordic race. I was in a different state than she'd seen me in. I wanted some answers.

David: Okay. So what you're saying is that there was some kind of bifurcation or time rift that occurs in their future that they believe is very maladaptive for them, and somehow, fixing it involves traveling 17 million years in the past.

So how did she explain what the value of going 17 million years in the past was? Why would that do anything?

Corey: They traveled 17 million years in the past, before the time anomaly that they were able to figure out, so that they could prevent the time anomaly and steward the timeline all the way through their current timeline to make sure that there were no, I guess, changes in the timeline.

Certain changes could cause them to not even exist.

David: Okay, so you say that they went 17 million years in the past. If we're talking about a fourth-density Earth civilization, that could be something where they've already gotten millions of years ahead of us before they did this.

So are you talking about 17 million absolute years, or are you talking about them traveling to 17 million years before our current present?

Corey: 17 million years in our past, from our current era.

David: Okay. And what I'm hearing you say sounds like the time anomaly that they were concerned about started very soon after that period of 17 million years in our past. Is that right?

Corey: That's why they chose that time period, to get there before the anomaly to correct it.

David: Do you have any sense as to . . . Is this anomaly like a geophysical event, like a catastrophe? Is it a solar flash? Do we know what the event is or any steps they took to fix it?

Corey: No information on that. I was circling back around to ask about the Nordics and what was going on and what type of interaction they were having with our group.

That was my . . . That's what I kept pushing back to in the conversation.

David: So if these are people from our own future, did something happen that . . . Was there some kind of karmic entanglement that they got, that they had to go back and fix? Is that part of what this is?

Corey: Going back and making that change in time did have karmic ramifications. So they are tied to us karmically in a certain manner to where – I've talked about other ETs – we have to progress in a certain way for them to . . . but that's organic for them, because if we progress the way we're supposed to, that's their timeline. If that makes sense.

David: Sure. Now, just so that we're clear, “The Law of One” stipulates that once you go into fourth density, you process time differently, and so 17 million years for them is not necessarily what it would be for us. Is that correct?

Corey: Yeah, it would be. If they go back 17 million years in our past, and they're living that 17 million years up into the present, then they're experiencing 17 million years. They may process the time a little bit differently, but they're still here experiencing it.

And they were not in contact with the Anshar from the future.

When they were put back here, 17 million years, they were like colonists, and it was from that small group that they've grown into what they are now.

David: Oh, really? So only a small group of people did this.

Corey: Yeah. They didn't send giant cities back, of people. It was small groups, and they've grown into these large cities underground they have now.

David: And you said that they were concerned that they might not even exist if they don't handle this properly? Could you explain that?

Corey: Well, if they don't handle . . . If they don't go back in time and fix whatever was occurring, there's a possibility that the timeline could shift enough to where they would never have developed.

David: Does that rely upon us and the decisions we're making right now?

Corey: Yes.

David: What would be a choice that we would make that might cause them to cease to exist?

Corey: Well, if we were taking steps that brought us away from the optimal temporal reality, I would guess; if we're doing anything that's going to keep us from progressing forward, according to their timeline.

David: So if we don't ascend, if we don't have this more positive, loving change in society, if we don't overthrow the Cabal, that kind of stuff, that could all lead to this happening.

Corey: Exactly.

David: Okay. I'm curious about whether you got into any dialogue with Ka'Aree regarding your meeting with the Sentinel that you had when they took you to Venus and this packet that you say got downloaded in your head.

Corey: Yes. That came up at the same time I kept pushing the Nordic issue. Finally, she let me know that there are agreements between all of these different groups. And a part of the agreement they have with this Nordic group was that they would not share too much specific information about the Nordics.

She said if I wanted more specific information, I needed to put the intent out there that I wanted to be in direct communication with them.

She said that I needed to basically get the information from them, according to the agreement that the Anshar has with this Nordic group.

David: Did she offer you any suggestions as to how you might be able to recover more of these memories, or any tools that she said you might be able to use?

Corey: Well, when it came to the zip file that I basically . . . was downloaded to me when I met the Sentinel on that space station, and also on Venus, she said that if I wanted to gain . . . I've been starting to have bleedthrough of information that I've been trying to process, and I've been going to her to help me process and make sense of.

She said that to get the information in a more digestible way, that I should consult the sacred plant. And at the time, I didn't know if she was referring to a plant on the surface of Earth or if she was referring to that drink that she had presented me in the beginning when I met her that was made out of a flower.

But I kept pushing and pushing for the Nordic issue and that conversation wound down with her unable to answer my questions further and me unwilling to stop asking the questions.

David: Do you think it's possible that if we pick our optimum timeline, that this breakaway group that traveled back 17 million years ago as a small group would eventually be able to reunify with their future selves in some way?

Corey: That would make sense.

David: Interesting. All right, so the last area we have here regards this current battle that's going on between the Alliance and the Cabal.

And it says here that you have been saying – what your intel is now – is that this war is not actually progressing. Neither side is really making progress at this point.

Corey: There has been a stalemate in this shadow civil war going on. We have aspects of the Deep State, that they're calling these groups in the government, which are basically career bureaucrats that weigh everyone else out and make all the decisions.

They also have the intelligence community, which is engaged in a battle of sorts against the military, a group in the military. And also within the Department of Justice, they're in a 50/50 split. And the intelligence community, it's a split more towards like 80% being Cabal.

David: The intelligence community is still 80% Cabal?

Corey: Right.

David: Hm.

Corey: So very little has occurred since they've tried to implement this, basically, bloodless coup in the United States.

What the military faction has pretty much decided is that the changes are not going to be able to be done in a bloodless way or in a legal way.

They think that they're going to have to do a full-on military coup here in the United States, which is very scary to think about, but we're at a point to where nothing's happening. No one's gaining ground. The Cabal isn't, and the Alliance isn't, and something's got to break.

So that was one of the things that I found out recently, is that they're really starting to discuss an open coup in the United States and a couple of other Western countries.

David: I know that a lot of this is obviously very sensitive, but on a basic level, what might that look like if it were to happen? What would we experience?

Corey: It would be, I am surmising from other coups in the past, that all of a sudden there would be tanks in the streets of DC, all of these government types would be ordered to stay in their quarters. Those who don't and come out to fight, will be engaged.

And they expect that it would be a nice little battle between some of the intelligence groups and the military.

David: Do you think it's possible that the Alliance might use unconventional technology as part of this?

Corey: Yes. I mean, unconventional technology has been used for a while in this battle, you know, playing with the weather, that kind of thing. So I could see unconventional technologies being used as long as it doesn't violate any agreements of using certain technologies in the open.

David: Well, I'm specifically thinking about things like . . . you mentioned these drones that could be various sizes that have propellers that we've seen in movies, but people don't know if they really exist. Do you think they might use stuff like that?

Corey: They could, but as I stated, it's going to be more of a conventional military if it indeed does occur, which has not been approved to move forward. But that is where they are right now.

Things are so contentious, there is such a stalemate, that they're beginning to think that violence is going to have to be used.

David: Hm. This obviously sounds a lot like this mass arrest scenario that I've been reporting on since at least 2011. And one of the elements of that appears to be that we're not strictly just talking about Washington, D.C., and we're not just strictly talking about intelligence, that there may also be actions against controlled media, financial centers, these kinds of things. What are your thoughts on that?

Corey: Yes, controlled media would be taken over. The banking system would be taken over. Yeah. All of the infrastructure would be taken over. It would be . . . When a coup occurs, it's basically shutting down the country.

David: What are your thoughts about the other thing we've heard so often, this idea that there would be, perhaps, a power outage during this time and that very few people would even know what had happened until it was over when the lights come back on?

Corey: Right. That's communications, power outages are things that they might implement during a coup. That's just a diversionary tactic.

David: So if something like this actually does happen, I would assume, **Corey**, that along with that process would be a lot of very ugly information coming out about how we have been lied to and about how we've been controlled.

And if that kind of information goes from being conspiracy theory to fact, how could people watching this show use a social event like that to help try to create a positive outcome?

Corey: Well, how about instead of waiting, sitting back and waiting for all of these things to occur, for these horrible things to occur, we empower ourselves?

We begin to get out, demand that technologies be released, demand that we want governments working together better, we want to have all of the corruption removed from all of our systems – not just the United States.

It's going to take the people standing up and demanding this.

If we're waiting for a coup to happen, or we're waiting for one side to win, then we're always disempowered.

If we can come together and start to work on getting a more positive outcome, then we don't even have to worry about a coup.

David: I like that. All right, this is “[Cosmic Disclosure](#)”, bringing you the latest updates, here with **Corey Goode**. I'm [David Wilcock](#), and I thank you for watching.

[Cosmic Disclosure: Viewer Questions 9: Time Travel and The Future](#)

Season 7, Episode 28

David Wilcock: All right, welcome to “[Cosmic Disclosure](#)”. I'm your host, [David Wilcock](#). I'm here with **Corey Goode**. And in this episode, we are taking your questions so that we have a nice interactive two-way dialogue going on here.

And **Corey**, welcome back to the show.

Corey Goode: Thank you.

David: All right, so the first question we have . . . This is interesting. I'm curious to how you're going to answer this.

“If we have a being that's in fourth density, does that being have unique psychic properties that we don't have, that would allow it to be able to see beings that are discarnate from our perspective?”

Corey: Wow, it is an interesting question.

I would think that some of them would at least have that ability to see disincarnate beings. But, yes, they do have enhanced abilities far beyond our own.

David: Hm. Interesting. All right, this one is a question that I really find interesting because I've talked so much about this Solar Flash. And I think I know how you're going to answer this, but you might surprise us.

“Why does it matter if the Earth Alliance negotiates a partial disclosure that will take place over the next hundred years or a Full Disclosure if this Event is about to take place?”

Corey: This Event may not be what each of us thinks it is. This Event might just be a catalyst for a disclosure of certain technologies. It could be a series of solar events, which has been postulated, that occurs.

Some of the first ones would possibly take out electrical grids or cause certain technologies with integrated circuits to no longer operate. And then they would have to come in and replace that with the new technology.

And that's when the Alliance was thinking was going to be the best chance to bring in that new technology.

David: Hm. Very interesting. This next question kind of goes along the lines of that one.

“Are the Alliance and their opposition aware of future events that are about to take place and how everything is going to change?”

Corey: The Alliance, along with all these different groups, are made up of other groups. And each of these subgroups have different ideas about what's going to occur.

And some of them are expecting like an Ascension kind of an event. Some of them are expecting just mass chaos, loss of technology. Some of them are expecting a lot of deaths.

So there's not one agreed-upon outcome that they're planning for.

David: You had mentioned that in the space program they actually took human beings and exposed them to energy fields similar to what would happen after the Event.

Corey: Leading up to the Event.

David: Could you describe, again, what that outcome was and does everybody have that intel?

Corey: Yes, everyone understands about . . . that they've received the intel from the Navy vessels that went out to the outer reaches of this energy anomaly. That's what they were calling it in the beginning.

The ones that were going out there, they were noticing that they were being affected by the energy. And they started doing further tests by putting people of different polarities – positive people, negative people – in a room and piping in this frequency to see how they would react.

And these people would be sitting down doing a job, not knowing that they were being tested, experimented on.

The people that were more negative would start becoming more agitated and claustrophobic and couldn't handle it.

And the people that were more positive would kick back and start to bliss out, smile, and start to daydream and not be affected by the other variables that they had in the room that they were using to try to affect the people.

David: So you're saying this was a Navy study, and that data has been shared with pretty much all of the Alliance groups?

Corey: Yes, the Alliance has it. All the information that the Cabal has, the Alliance has that information.

David: Okay, but even, I guess, within the fact that it seems to amplify and potentiate people's innate state of being, there could still be a great deal of scholarly debate as to how that affects us as a collective.

Corey: Right. And then there is the aspect that some people want to weaponize it. They have a lot of different plans. They've been studying this for a long time.

David: Okay, next question is:

“The Law of One' only speaks of there being eight densities where the eighth density is a return to the oneness of the universe. Can you clarify then what would a ninth-density being represent?”

Corey: I don't know all the different octaves. I've been told that the octaves returning back to Source . . . if there wasn't an end to it, it would seem as though they were going on forever.

David: *“Are Raw-Tier-Eir and the two others who also use the Raw prefix to their names in any way associated with the same social memory complex entity that was speaking to the people who wrote down the original 'Law of One' material?”*

Corey: They have confirmed that they were involved in communicating 'The Law of One' material.

David: *“After you were age regressed, although you are now 45 years old biologically, is your soul actually 65 years old?”*

Corey: I would have to say, “Yes”, because I still have those extra years of experience.

David: *“Have the USSR and Russian leaders been involved in the Secret Space Programs?”*

Corey: Absolutely, definitely since the '80s. Before the end of the Cold War, we were already working with them on a very high level.

Now would certain generals in the USSR military know? No, they were . . . The generals on both sides believed that the Cold War was real, and they were prosecuting that war thoroughly.

Above them, things were going on a different level, compartmentalized level, to where the Russians and the Americans were working very closely.

David: When we saw the book “Alternative 3” come out in the 1970s, it was describing secret collusion between the U.S. and the USSR going on all the way back at that time.

Do you think it's possible that this was earlier than 1980s, based on data like that?

Corey: Yes, especially the early continuity of species programs were joint programs. They went back pretty far.

David: I want to share with you something that one of my other insiders told me and see what your thoughts are.

He got a job in the 1980s for one of the most serious intelligence agencies. I won't say which one. And he was really shocked because he said, “Aren't we at war with the Soviet Union?”

And they just started laughing. And they said, “That's just for the newspapers”.

Do you think that a lot of people that would get these kind of intelligence jobs would find out at some point that this whole Cold War nuclear threat thing was really just a scam?

Corey: Seen a lot of the behind the scenes, I'm sure they would extrapolate that eventually. But I don't think it was common knowledge documents at the ready information.

David: *“Do you have any update regarding the negotiations going on between whether we will have partial disclosure or actual Full Disclosure?”*

Corey: Right now there is a major stalemate going on between the Alliance and their proxies within the U.S. military forces and what people are calling the Deep State – mainly the intelligence community and the bankers.

So there is a major stalemate going on right now between the two. There's not a whole lot of movement.

It's gotten to a point to where the military aspect believes now that there is no peaceful way of making a transition away from the Cabal. They think that they're going to have to have a military coup.

And they think that a military coup will curtail whatever type of civil outbreak will happen. There's major factions of ideologies that are being pitted against each other right now to try to get our attention away from this civil war going on.

David: *“Is the Cabal's preferred method of disclosure the type of slow rollout that we are already seeing right now? Have there been AI predictability computer systems used to design this partial disclosure gradual strategy?”*

Corey: Well, these groups have definitely used an AI technology to get an idea of what's going on in different probably futures.

From what I've understood, it's that this technology has not been reliable recently for them. There is something that has occurred, maybe this Mandela Effect thing, who knows, that this technology is not as useful to them anymore.

But they definitely have, in the past, used that technology. That's why so many times there have been opportunities to take down this Cabal, but they've found a way every time to escape it by using this technology.

David: So the core of the question is, does the Cabal prefer this low drip, drip, drip disclosure that we're already seeing, or is there some point maybe where they want to do a big blast?

Corey: Well, there was a plan to have a few big blasts, not a Full Disclosure, but disclosures that would definitely get the attention of every human being on the Earth.

If stuff starts to come out about their crimes against humanity – boom, “We found pyramids under the ocean”. Boom, “New information: We found weird artifacts in Antarctica,” you know, to kind of distract you and throw you off.

So they'll use disclosure as a way of distraction and manipulation as well.

David: *“Is there a limit to how many times you could send someone back in time before certain inescapable health consequences or other things would take place?”*

Corey: Definitely, especially with the early technologies. Such high electromagnetic fields are used that even when people that spend 20 years in the space program, being within those high electromagnetic fields, they have a lot of side effects: the temporal dementia, different types of neurological issues, weird numbness.

There are a number of issues that occur from being inside those magnetic fields. So, yes, if you're sent using the technology, especially that they used to use a long time ago, sending you back in time over and over would be like working in the engine room of one of these torsion drives.

They wear these Faraday suits that are like a metal mesh that go all the way over them when they're in these.

So, yeah, it's very detrimental to the neurological system.

David: So is there any contraindications for people's lifespan if they've been in the Secret Space Program?

Corey: Yes. Usually the people that have either retired or have gone through a 20-and-Back like myself, they have a lot of neurological issues for a while. Their quality of life tends to go down, down, down, and they do not have the life expectancy as the rest of the population.

That's a tradeoff that they make, and most of them knowingly make that tradeoff.

David: One of the things we described in a previous update is that you have had new information come your way about there having been more than one 20-and-Back program.

So how does this new knowledge impact the question that's going on here, which is, is there a limit to how many times somebody could be sent back in time?

Corey: Yes. That information was relayed to me through Gonzales when I was up getting an examination on the Mayan craft.

And they had actually repressed two of the 20-and-Back memories from me when they first met me.

Because when I had the eye surgery, when I had a detached retina that they said was basically the same as astronaut's eye, I had full recall of all three 20-and-Backs.

David: Oh!

Corey: And I was almost suicidal. It was bad.

And then they came and assisted me by removing some of my emotional energy to some of the memories of this 20-and-Back, and then rebury the memories of the other two.

The memories were not conducive to me having a normal life.

David: So given that you are a person who now believes that you've had three 20-and-Backs, that would make you, I guess, with a soul age of like 105 or something like this?

Corey: Yeah, something like that. So how does that affect you in terms of your health and your functionality?

It's definitely had side effects. I've had a number of surgeries because of neurological issues with my hands and forearms, which is common.

I'm starting to have issues with memory recall a little bit, having, what is that, aphasia, where all of a sudden you can't remember your normal words out of your lexicon. It's like it's been erased.

David: Sure.

Corey: So yeah, there are a lot of different side effects that I'm dealing with currently.

David: Are you aware of anyone having had four or five or more 20-and-Back experiences? Does that ever happen?

Corey: I'm not aware of them, no.

David: So you think three might be as far as it ever gets pushed?

Corey: I have no idea.

David: Has anybody ever died from having done a 20-and-Back that you know of?

Corey: I know that people have died while on 20-and-Backs, but I have not known of anyone that has died in the process of the 20-and-Back, the pharmaceutical process or the temporal process.

Now, I'm sure at the beginning when they were developing this technology that was passed on to us by nonterrestrials, they definitely broke a few eggs before they got the omelet right.

David: How do they handle it when somebody dies in a 20-and-Back? How do they bring those people back?

Corey: Well, if they're military, and depending on the situation, they'll receive military honors. But if they're a civilian on the 20-and-Back, they become a missing person.

David: So you can't age regress a dead body?

Corey: You know, they could probably go through the process of cloning a body at the right age and then replacing it there, but really what occurs is that there's nothing to return home in that time period of the return. So you don't get returned home. And parents come in the next day, you're gone, missing person.

David: Do we know which extraterrestrial group gave us this 20-and-Back age regression technology? Was it the Draco? Was it the Anshar? Do we have any idea how the space program got this?

Corey: We got a lot of our stuff from a Nordic group.

David: Oh, really?

Corey: Yes.

David: And would that be an Inner Earth Nordic group?

Corey: I'm not sure. They don't claim to be. They claim to be from another star system.

David: Okay. Is this kind of 20-and-Back thing a fairly common strategy that's employed throughout a variety of other worlds besides just Earth? Is this a common practice?

Corey: Seeing that they had a in-the-box type of solution all ready to deliver to us, I would assume that, yeah, it's being used on some level on other planets.

David: You had said before in one of our other updates that you would have people in the space program who had been pulled from various eras of Earth's history simultaneously. I'm curious about how those people from – like you said, some of them might have been from the 1950s . . . Is that a process of time travel that is required to get them in the first place? How are they picked up?

Corey: Yeah, they have to go back in time to pick them up. And then once they pick them up, and they serve their time, they bring them back to that exact time period.

David: What would that look like for somebody in the 1950s? Would they see something like a UFO contact or how would it happen to them?

Corey: I have no idea. Yeah, that's not information that we were allowed to share with each other.

And I've seen people that obviously were from different past eras. Was not common, but you would see it.

David: So here's an interesting question:

“If we're about halfway out from the center of the Milky Way, towards the edge, we're moving along at 1,000 miles per hour, there is some kind of spatial displacement . . .

Corey: Right.

David: . . . *as we're moving through that galactic space, how do they compensate for that in this 20-and-Back protocol?”*

Corey: They're taking a person and putting them 20 years back in the past. Now, 20 years back in the past, the celestial mechanics were different. They've changed. It's like a giant clock that's turning at all times.

Just like they have calculations for the Cosmic Web on how to travel between different stars and arrive there at the correct time period, they have the same mathematical model for going back in time. So they're able to calculate it.

David: Are you aware of there ever having been people from Earth's future that were getting pulled in just like people from the 1950s may have been pulled in?

Corey: I've heard that there have been people from the future that have been picked up here while coming here to do recon. I don't know anything beyond that.

David: If you have somebody from the 1950s and somebody from the 1980s pulled from Earth, working in what is now the same time for wherever they are, how does the space program avoid time paradoxes?

In other words, wouldn't that person from the 1980s at some point toss out a cultural reference that could somehow pollute the mind of the guy from the 1950s?

Corey: Sure, if the person from the 1950s wasn't blank-slated.

David: So the blank-slatting would eliminate any memory of him from something that would be in our future?

Corey: Right.

David: But you also said that 4% of the time it's not effective.

Corey: Yeah, 3 to 5% of the time. And then they have to mitigate those problems when they occur.

David: “Mitigate” meaning like reabduct the person, that kind of thing?

Corey: Yeah. Reabduct them or bribe them or who knows.

David: We also seem to hear from other insiders I've spoken to that time has a natural repairing ability for itself.

Corey: Yeah. Time is elastic just like space is. That's why in the beginning we were trying to go back and fix these different paradoxes that we had created.

And the nonterrestrial groups told us, “Stop. You're just making it worse.” In time, time will snap back. It'll correct itself.

David: *“In previous episodes of ['Cosmic Disclosure'](#), you were posed a question about yourself. The question was, do you want the knowledge of who you were, who you are, and who you will be? If you were to get another chance to answer this question, would you now answer, 'Yes, I do want to know', and why?”*

Corey: I think I'm close to being ready. I'm doing a lot of work on myself – a lot of things that are being pointed out by these beings that I need to change.

But I think a lot of this information was actually downloaded into me when I had that meeting with the Sentinel on that station and all of the information was downloaded. I just haven't had access to it.

I think it's a process of working through that information to gain access to it.

But if I'm asked the question again, it depends at the moment where I am. Right now just the feeling I

get from it, it's an overwhelming experience. And it's one that's changed Gonzales considerably. He is literally a different human being. He only looks like the guy I knew before.

David: Okay. This is, I guess, just a general personal guidance and philosophical question based on what you've been through:

“How can someone make peace with past and present experiences that are negative in order for them to be able to heal themselves, not feel that they are stuck in their life, and move past any feelings of vulnerability and lack of trust of other people?”

Corey: Well, you can't bury them. You have to confront them head on. A lot of them are traumas that you're going to need help [with] from a professional. Don't try to do it on your own.

But if you want to, I guess, evolve, you've got to begin to focus on those traumas and be able to get to a point where you can speak about them without feeling the energy connected to the trauma.

It takes a lot of work, but I've been able to do it on several different topics, and it's been very painful. I've had to just confront things about myself that I didn't want to do.

If you're in a place in your life where you can do that, then go for it. If not, then do the work that it takes to get there.

David: Very well said.

“Are there only two timelines: the one that we experience here on Earth and the one being experienced by the Secret Space Program? Or does each new person brought into the Secret Space Program create a new timeline?” I guess that's the first question.

Corey: Timelines, realities, they're basically the same thing. There are many, many, many different realities and timelines. So there's not just the two.

David: Okay. The next part of this question is:

“Do two versions of the same person exist at the same time? Would there be one that is enhanced and

highly trained, living off-planet, while the other version of themselves is living a normal life on Earth?”

Corey: Those are two different timelines. So it depends [on] how you look at it. I mean, if you look at it as during the same time, not split off or segmented from each other, then, yes, it would look like they're coexisting at the same time. But they're two different timelines.

On one timeline, you're in the space program and there's a missing person's report out on you during that time period on Earth.

On another timeline, once you're back, you're going through your reintegration period after being placed back here from the Secret Space Program, if that makes sense.

David: All right. Let me ask you this. It kind of falls in line with your question. They're talking about that you would be enhanced but highly trained off-planet.

So could the people doing the space program roll back enhancements and high degrees of training as they do the regression process when you get brought back into your regular life?

Would you lose the training and the enhancement?

Corey: The training you can get back. It's compartmentalized. The training, the knowledge, the experience is still there. It's compartmentalized. It's been blank slated or removed from your ability to pull it into your immediate recall.

David: Hm.

Corey: So, your skills are retrievable. Now, the abilities, if it's a chemically-enhanced ability, you're going to have to go through the process again of them building up the chemical in your body and then your body adjusting to the chemical.

David: The next part of this question is:

“What happens to the off-planet timeline once the Secret Space Program worker has been regressed and sent back to the moment that he first left?”

Corey: The timelines . . . That other timeline still exists. You're just now on this timeline.

David: So, in some way, people's idea of a nice organized linear time isn't really working when you're talking about timelines here.

Corey: Time is not what people think it is. We're just starting to get an idea about how gravity and space works and the torsion of space. Time works in much the same way. It can be manipulated and stretched and merged in some cases with other timelines.

David: Okay. So we have one last question for you here, and that is:

“What specifically can the average citizen do to actively promote disclosure and gain the greatest impact?”

Corey: Well, I definitely wouldn't go out and start talking about little Gray aliens or eight-foot tall blue birds in the beginning. Ha, ha.

David: Ha, ha. You learned that one the hard way.

Corey: Well, yeah. You know, I had no choice.

David: Right.

Corey: I think that the best thing that all of us can do is start to focus on the suppressed technologies that we want released – start focusing on that.

If we focus on nonterrestrials, that's already a topic that's been programmed into people to resist.

Now, if people start finding out that maybe the government has technology that could cure cancer, maybe they have technology that's zero point energy. That is something that the average person could think of as more tangible that they could get behind.

So I think that we should focus more on the nuts and bolts part of the Secret Space Program in the beginning and try to get that disclosed to get the general public interested and just to a point to where they're not going to shrug their shoulders when they hear “ETs” or “aliens”.

David: How do you feel about people who are watching this show and having access to the Internet? What can they do with the Internet to help this process along?

Corey: Get petitions going, make comments, spread the information as much as you can. Also with your family, don't go talking about aliens to them. But I think the best thing to talk to them about is suppressed technology.

Everyone can . . . Just about everyone can believe that the government has technology that's 50 years ahead as a part of national security. But if they start thinking, "I have an aunt that's about to pass away from cancer".

If I was able to get those technologies out right now, I would. And there are many people out there who have loved ones that are going through this.

I can't think of anything else that will motivate people to get out and demand disclosure.

David: Do you think there's an opportunity for journalism to be done with articles and blogs and videos that isn't being done? Or do you think that everything that could be covered has already been covered?

Corey: I think that it can be done in a way that is easier to disseminate to the general population. I think if a lot of us in this field begin to focus on that and try to get the general information out about the Secret Space Program, the technologies that would change our lives, I think that that's going to cause a groundswell of people asking for disclosure a lot more than us talking to them about crashed aliens in the desert.

David: I agree. Well, you heard it here first. This is "[Cosmic Disclosure](#)". I'm your host, [David Wilcock](#), here with **Corey Goode**, taking your questions and answers and handing it back to you with action points you can use to help make this disclosure reality. Thanks for watching.

[Cosmic Disclosure: Testimony on Pyramids and Underground Cities](#)

Season 9, Episode 29

David Wilcock: All right. Welcome back to “[Cosmic Disclosure](#)”. I'm your host, **David Wilcock**, and we have a special surprise for you.

This is **Pete** Peterson, coming back a year later after our last taping, and there's a lot more that he's been authorized to talk about. So without further ado, I bring you **Pete** Peterson.

Pete, welcome to the show.

Pete Peterson: Thank you.

David: So you have so much knowledge. It's pretty amazing to try to even figure out what we could talk about first, but we were talking about this before we started.

And it seems like a good place to begin would be the fact that we have pyramids. There's over 500 pyramids in Mesoamerica made of gigantic blocks. There's over 100 to 120 of them in Egypt. And then there's many other cultures around the world that all seem to get the idea to take gigantic, multi-ton blocks of stone, carve them very precisely, and put them in these amazing monumental structures.

Everybody wants to know, what is the insider view of this? Based on your personal experience with government top secret programs, what did they speculate was going on there? Do they have any idea as to how these were built? Does it have anything to do with extraterrestrials?



Pete: Well, I'm going to divert just a little bit here at the first to explain that when I was growing up, I learned to read very early. And the things that I was most excited about was anthropology and archaeology, and King Tut's tomb was big, and etc., etc. And so I wanted to be an anthropologist/archaeologist.

Because of that, every time I've had a chance to stick my nose into ancient archaeology, I've done it.

David: Okay.

Pete: They were obviously built with alien or at least certainly far advanced knowledge from the people that built them.

David: Sure.

Pete: And not necessarily the people that ruled those societies, but at least the people that built them.

So we had a priesthood class that had a lot of knowledge. We had a scientist class that had a lot of knowledge. And they were at the top of those societies.

David: Hm.

Pete: So we had knowledge that we haven't had since that time because, eventually, these societies moved elsewhere or perished for one reason or another – many times because of getting into war with each other.

They were built because, think of it, this is a concentration of mass. Even the Earth isn't all rock, but these were all stone. They were very, very heavy.

They were built in a specific - they called it a “religious mathematical structure”.

David: Uh-huh.

Pete: There was, in their mind, a religion or philosophy-based thing to start with. Secondly, because they needed the informational structure and the informational field that was generated by this much mass in a particular shape at a place and time.

And it allowed them to do ceremonies. It allowed them to do – we'll call it – extraterrestrial communication.

David: Hm.

Pete: It enhanced the – I don't know what other words to say than – psychic talent or psychic abilities of the priesthood that used them.

David: So do you think, **Pete**, that there was some sort of amplification of the spiritual aspect of that civilization where the pyramid or giant stone structure was built?

Pete: Very definitely. And I think I'll call it “informational”.

David: Okay. What was the effect of spiritual, or as you say, informational, effect on that society? What would the people feel? Or how would it change them when this pyramid was built? What would that look like?

Pete: What we live in is like three separate universes that are one inside the other inside the other with no border.

David: Uh huh.

Pete: And so most of the things that we do in our life here is in two of those fields. And then the informational field is the background of it, and it's what's responsible for what religions call the soul or the spirit.

It's responsible for a good part of what goes on in things like remote viewing, remote influencing.

A lot of it goes on with leadership abilities and what we call the Cabal today . . .

David: Hm.

Pete: . . . and people who have more knowledge than the average person. They have different training. They have considerably different DNA.

They're remnants of very ancient, very, very ancient, back to probably as much as 200 million years or maybe more, of beings that have inhabited the planet at one time or another.

David: Hm.

Pete: And it's what's behind all the esoteric and spiritual writings of the world, despite what, it may seem, quite a bit different in these religions.

A religion has power only because of what it knows that the average person doesn't know.

David: So let me ask you this: What do you think is responsible for these huge stones being able to be fit into those giant structures? Graham Hancock, and guys like that, have pointed out that there's no crane that is capable of lifting those stones in today's world.

So how do you think those stones were moved?

Pete: Oh, they were moved with anti-gravity devices or anti-gravity thought.

David: What would that look like if we were there and could witness this happening?

Pete: It'd look like they were floating, and several people were moving them.

David: Some of the pyramids are widely known. The ones in Egypt, the ones in Mesoamerica, are widely known. But then we have some really strange stuff that most people don't know about, like, for example, about 100 pyramids that show up in China that have flat tops and look kind of like the ones in Mesoamerica.

Why do you think all these different cultures all over the world keep getting the same idea to build such similar-looking structures?

Pete: Well, because it's the structure that gives us its power. It gives us its capabilities. It gives us its utility to the people that are building them.

Most of the flat top pyramids had tops.

David: Hm.

Pete: As time passed, technology advanced, and they learned to build the top little pyramid that sat on the flat top, or truncated pyramids, were able to be done by, as best I can say in English, imagination.

They were actually physically present, but they were there as something imagined – something conjured.

David: Like an energetic structure?

Pete: Like an informational structure, the information structure includes physicality or not, and it includes energetics as well – the power for it. And it includes a shape knowledge.

If you look at the . . . The Tibetans are not an ancient civilization, but they have yantras or shapes that are very, very powerful that they use in their sand paintings, they use in their prayer wheels, they use in their fabrics, they use in temporary drawings that they make for powering something up and causing things to happen.

So there are some societies that call them holy charts or holy graph – 'holy', H-O-L-Y, graph.

David: Uh-huh.

Pete: And, probably, they're more powerful than physical things.

David: How were these pyramids used to communicate with extraterrestrials? How was that done?

Pete: That wasn't what their use was. I mean, they would do rites and things inside of the pyramids as holy structures.

David: Uh-huh.

Pete: Just like in the church, many people go to the church and pray at the church. So it's the center of what would be psychic or holy activity, but it isn't that they used the pyramid for that. They just do it there because it generates fields, informational fields, that are very powerful. But it doesn't work like our communication works. It's completely outside of the physical realm thing.

David: Uh-hm. Are there any pyramids that you know of, or other structures like that, that have not yet been discovered?

Pete: Oh, there are many. There's a lot of underground cities that have pyramids –

David: Hm.

Pete: – ancient underground cities. There are some that haven't been discovered. There are some that were filled up by the natural things of being underground. In other words, there have been several different floods or deluges that have washed them full of sand, or clay – a lot of clay and sand, small particles – and they're clear full, but they're buried underground.

Those have been pretty easily mapped, inadvertently, by spy satellites we've built for looking for underground laboratories.

David: Hm!

Pete: And so you see these structures underground. There are tons and tons of them that have been talked about, but nobody has done much about it, that are under the ocean.

David: Are there any pyramids in Ohio that have not been publicly disclosed?

Pete: I don't know of any that haven't been publicly disclosed, but the people probably doesn't [don't] know about it.

David: Right.

Pete: So they're digging them up there. There are three pyramids that I know of and have seen that are three times larger than the largest pyramid in Egypt.

David: Wow!

Pete: They were part of a city of 15 million people . . .

David: Hm.

Pete: . . . that's been discovered. That city is written about a little bit in the Book of Mormon, for example. The Book of Mormon is not the Mormon Bible. It's a history of the American Indian, . . .

David: Hm.

Pete: . . . and it goes way back. But they're unearthing a lot of that right now.

There are a lot of laws about unearthing archaeological sites, and the problem is that you have cities built on it. Three-quarters of the city has cities built on it.

David: A lot of these books that I've read about the mounds and when they were originally being excavated, even going all the way back to Lewis and Clark going west and exploring America, it seemed like they kept finding giant skeletons in there, and these giants were sometimes nine feet or more tall.

So do you know anything about the giants and how that relates to these mounds or pyramids?

Pete: Well, these were the people who were here, living here at the time, and building those things, and breeding with the . . . There's been a long, long long breeding program to breed with Earthlings.

When I was a child, we used to visit museums where there were samples of . . . there were skeletons of red-headed people. The hair always seems to stay. Red hair seems to stay better.

But there were museums you could go to, especially in Oregon, where there were people up to about 12 feet tall.

David: Wow! Right on display?

Pete: Right on display. Very near there was a place that they used to mine obsidian for making primitive tools.

This was right after they came to the Earth, and they needed weapons, and they hadn't located . . . here's the steel, and here's the copper, or here's the iron.

David: "They came to Earth." You're saying the giants are extraterrestrial humans?

Pete: Extraterrestrial.

David: Okay. Do you know where they came from?

Pete: We don't have any idea where they came from. There are some that we know where they came from. Some were from Arcturus.

David: But in short, what you're saying is giant, extraterrestrial, human-looking people – people that look pretty much like us but are tall – somehow came here. But then you're saying they had to make tools out of obsidian.

Why wouldn't they have had laser guns and all kinds of cool things like that?

Pete: How many people can you get in a spaceship?

David: I guess it depends on the size.

Pete: And then you'd land on a planet, and what do you have? When we go to Mars, we had to terraform it. When we went to the back of the Moon, we had to terraform it.

You didn't go there, and “here's stacks of steel and stacks of aluminum and stacks of tubing and stacks of girders.”

David: Right.

Pete: So you come there, you have to take a period of time, and it may take quite a while. We're talking now about one of our pseudo enemies or enemies, like North Korea or Russia, popping a couple of e-bombs that would put us back probably 90 to 100 years before we even had electric power in the country again, because we have to build those things.

And we don't have certain phasing transformers and things like that. We don't have large stacks of them waiting to replace something that somebody else blows up.

And when you come to a totally uninhabited planet or a system of planets, you don't have all the building tools there. You have to build the tools to build the tools to build the tools to build the product.

David: Now, I've noticed that a lot of these giant skeleton reports – because I've looked through as many as I can find, and there's hundreds of them – they seem like they have elongated skulls compared to us, which suggests that their brain would be larger for the body than our equivalent.

Pete: Probably it's as much as sometimes five or six times larger. The brain . . . If you look at the shape of the body of an octopus or a squid, even more especially a squid, I think they're probably degenerate DNA products from those kind of people because they look exactly from the side, they look exactly like it.

You have a front cortex area, and then you have a thing that looks like a bag hanging on the back. And that's the way their brains looked. That's the way their skulls looked.

David: To your knowledge, did these giants mess around with DNA on Earth? Did they try to breed themselves out?

Pete: Oh, of course, absolutely. They tried to breed with Earth women. And let's look at what we would do. Most of our spaceships have had mostly men, and you get somewhere, and you know you're going one way, so you get creative.

So not all of them, by the way, in fact, very few of them actually had that type of skull structure. Some of the larger ones did. Some of them had a skull structure almost exactly like ours.

David: Were those different races?

Pete: Different races, and there are very, very different races.

David: So these giants come here with what . . . I'm just going to infer. Since you said that indigenous people built pyramids, the priestly caste was in touch with extraterrestrials, I'm assuming these giants were one of those groups.

Pete: No, the priestly caste were extraterrestrials.

David: Oh, they were? Did these giants bring anti-gravity technology with them? Is that part of what they . . .

Pete: They came that way, a lot of them.

David: Okay.

Pete: Again, when you come to an absolutely undeveloped planet, it takes a period of time to . . . especially when you have to change YOUR DNA so that you can live on the planet, breathe the gases that are here, not be toxified by some that wouldn't be toxic to us but are to them.

I'm relatively certain from things that I know and I've seen, and remembering that basically I'm a scientist, but I'm also an amateur anthropologist/archaeologist, I would think that there have been

people here . . . Like I've had access, several times, to the Great Library of Alexandria, which we call the Vatican Library.

David: Right.

Pete: And it has different floors, and it's rated by how many years old the materials that are there.

And you go through several layers where there was writing and several layers where there wasn't writing.

We've had civilizations come and go, come and go, come and go. Some left to go elsewhere because one of the main reasons for going to another planet . . . It's an expensive process no matter who you are or what you have. It's time-consuming and expensive.

They came here to get raw materials.

David: How far back do you think civilizations on Earth that were intelligent have gone?

Pete: I think at least 200, 250 million years.

David: 250 million years?

Pete: Right. I mean, there's evidence for it. For example, in coal mines, we've had some coal mines that go down 3,000 to 4,000 feet. And in the mass of coal, they've broken out astrolabes, which are navigation devices that were set up for navigation throughout at least this galaxy, the Milky Way.

And these were semi-primitive in some ways, but absolutely perfectly filled the job.

David: If these giants come here with technology that can levitate stone and can work stone to make it basically floating like that, did they do anything underground? Were they able to manipulate stone underground, make caverns, anything like that?

Pete: Well, there were a lot of caverns that . . . And again, in the beginning, they came here, nothing was here except what was natural to being here.

There are a lot of places on Earth, because of the type of structure from the Earth, like in Arkansas, a

lot of limestone . . . Limestone gets eroded away very easily by water. Lots of natural caverns there. Lots of natural caverns in New Mexico.

They inhabited those first because they needed protection from the Sun, because the Sun goes through about a 29,000-year cycle. Where it's now going into a cycle where we're probably all going to have to live underground.

And I think that opens up the fact that there's a lot of underground things. They did build underground. There are a lot of things underground.

I've visited a lot of highways, I'll call them, underground in South America that are well-known and well-documented. But you go in these underground tunnels that are at least as big as the Chunnel they built from England to France under the ocean.

David: Wow! Tell me how these tunnels that you saw in South America, or wherever else, looked. If you go inside one of these . . . because everybody would love to see this, but we're not generally allowed to. I don't think anybody's ever gotten to film it.

Pete: Oh, there are books, and books, and books written on it.

David: Yes, but nobody has been able to film it. So if you saw it yourself, could you describe what it looks like for us?

Pete: I saw tunnels that had a flat bottom, had a kind of oval-shaped top to them. Now those look very much like natural volcanic tunnels, but they're not. They were actually put in there.

The walls are glass, but it's a flexible kind of glass. And they go for miles, and miles, and miles.

I know I've been on a little vehicle like a moon buggy that they do tours with and so forth, that goes, probably, . . . I think I've been as much as 120 miles down one tunnel.

David: Wow!

Pete: I did highway engineering at one part in my life, and they're obviously designed by engineers. They wouldn't appear naturally at all, and they wouldn't appear even with somebody that wasn't a very sophisticated engineer.

With a tunnel, when it was going over a hump, let's say, it ramps up to the hump, stays on part of a cylindrical surface, and then ramps down to another flat.

David: So help me visualize this. Are you talking about sharp-edged walls that look like it's laser-cut drilling? That kind of stuff?

Pete: Yes.

David: Okay. And you say it's a glassy . . .

Pete: It looked like you had a great big oval drill bit that just drilled it.

David: Wow! But it was flat on the bottom?

Pete: There are places in the early tunnels . . . Remember, time progresses, technology moves. There are places in the early beginning where you could see that it was ground off by some kind of cutter, like an oil well cutting head, where there were striae in the walls. So there wasn't an engineering reason for that. It was because that's the kind of cutter they were using.

Later, they advanced and developed, I'm sure, laser technology.

David: Why would human beings make something underground that was anything much taller than their own heads, because why would you create all that extra space if you don't really need it?

Pete: Because you need the air flow.

David: Oh!

Pete: Or the oxygen flow, or the gas flow.

David: Do these tunnels go to cities, or are they just long roads? Is there other . . .

Pete: Well, the ones that I've seen in South America appear to be roads.

David: But roads to where? Is there a . . .

Pete: I wish I knew.

David: Okay.

Pete: Like I say, I went 150 miles and turned around and came back. We ran out of gas.

David: Did you see any inscriptions on those walls?

Pete: Oh, absolutely.

David: Oh really?

Pete: Oh, yeah, there were . . .

David: Like what?

Pete: Well, symbols, yantras. There are yantras there to protect the people. There are yantras there to keep the glass flexible.

David: Yantras, like mandalas, you mean?

Pete: Like mandalas, yes.

David: Wow! So geometric patterns.

Pete: Geometric patterns.

David: Interesting. Now were these just like engravings in the glass, or was there also color?

Pete: Well, they were engravings, but there had been some type of colorant rubbed into them many times, and many times just an engraving.

David: Did you ever see pictures of people, or spacecraft, or anything interesting like that?

Pete: Never saw spacecraft, but I did see . . . There are various ones of them that have people.

David: Hm. Did they look the same as us, or was there anything unusual?

Pete: They looked like normal . . . minor variations of us. Like there's so many people that are seven feet tall, and there are so many people that are four feet tall. So you'd see the variations. And probably by the percentage of people who lived there at the time, was the same percentage you saw in variations of people on the wall.

You'd see a few small people, and eventually, you'd see a few tall people, and eventually, you'd see a few people that we'd say were within the boundaries of what our shapes are now.

David: Were the different sizes of height of people co-mingling in the same images?

Pete: Sometimes they were, and sometimes they weren't.

David: Are you aware of anyone finding unusually technological gadgets down there, like a hologram or a laser?

Pete: I know of nothing that was found in South America like that.

David: Okay.

Pete: And I mean, I looked, because I'm a technical guy, and I'm a . . . So it's one of those things I look for.

For example, I found tons of things in the British Museum that they had stolen from people that they . . . You know, the British ruled the world at one time.

And then the British Museum, and in the bottom of the Smithsonian, for God's sake, there's multiple stories of all kinds of stuff that they don't have the slightest idea.

David: Was there anything in the British Museum Library or the Smithsonian that you got to see that was so jaw-droppingly, obviously technological, like a really nice metallic form that looks very futuristic. Did you see anything along those lines?

Pete: Not along those lines, but I saw craft. I saw vehicles.

David: Really?

Pete: Yeah, in the structures itself, they were structures, a place to stay out from under the Sun, and under the rain, and live.

I didn't see people like you'd expect to go to New York and see highly architecturally decorated and built houses and things like that. I didn't see a lot of that kind of thing. And that's from an anthropological aspect rather than an engineering aspect.

They had, obviously, very advanced technology in building things, but as you would go from the tunnel entrance . . . very crude.

And as they built these tunnels, they were probably looking for minerals, and then a place to put more people, because there were quite a few people we know of that came here because their planets were crumbling or their system was crumbling.

And we're in a place where ours was going to go through a little spout of that, bit of that, but it's gone through it 12 or 13 times in the history that I know of, . . .

David: Hm.

Pete: . . . because we have this 29,000-year solar cycle.

David: Right. Earlier in our interview, you mentioned that there were underground cities that you said actually had pyramids built into the city.

Pete: Yes.

David: Could you tell us a little bit more about that, and is there any relationship between that and these tunnels?

Pete: Well, yeah, there has to be a relationship between the tunnels because that's how you get to these cities.

David: Okay.

Pete: And there are cities that are very large. There's one, there's a waterfall and with an automobile driving light – which is probably, I don't know, 300,000 candlepower – you can shine up, and you can

just still see it coming. You can't even see where it fails from – in a mountain in Utah that I've been in extensively – and it's a 12,400-foot mountain very near population.

It's got several different caves that are commercialized, that are owned, probably, by the government or maybe by private parties, I don't know, but I've been in.

Some of them, you can go back in these caves as far as 17, 18 miles. You can row across a lake that you can't see the other side of. That's got a waterfall that's falling.

And this whole mountain, the very top of the mountain . . . I've hiked to the top of it when I was much younger and in much better condition. I've gone up to the 12,000 [foot] line. I think it's 12,400 and some feet.

And the soil right there is loaded with seashells, ancient seashells.

David: Hm.

Pete: So that whole mountain has risen up since we had these particular type of brachiopods and other types of sea creatures.

David: If pyramids have been found in underground cities, do they have a similar composition to the pyramids we see on Earth? In other words, are they made out of blocks of stone that are fit together? Or is there something more bizarre about those pyramids than the ones we see on Earth?

Pete: I see nothing more bizarre. They're made out of the materials that are usually nearby or inside.

David: Okay.

Pete: And remember, we're building that for its shape because its shape affects one third of the universe as to information.

David: Sure. I've done a lot of episodes of Wisdom Teachings on pyramid technology and how the actual shape does create these effects – very bizarre effects.

Pete: Absolutely.

David: So you're saying, then, that there's a civilization where the pyramid is not going to hit the roof of this interior cavity inside the Earth.

Pete: No. And also, we talked earlier about the truncated pyramids. There are truncated pyramids underground. That was more modern because we learned how to do . . . like, for example, the Great Cheops Pyramid. We know it had capstones on it that filled in the steps of the pyramid.

David: Right, the casing stones.

Pete: The casing stones. And they came down a certain way and stopped. That part of the pyramid and that shape, the rest of the pyramid concentrated information, and then that information sat up there in that top part and beamed up.

David: Are there any cities in which some of these people that built them actually still live and have survived?

Pete: As far as I know, the only one that I know of is the one in Antarctica.

David: Could you tell us a little bit about that?

Pete: Well, there was a crash there about 200,000 years ago. And at that time, it was tropical. There were palm trees there. Where the crash was, there were palm trees. That's about three miles under the ice now.

That's being excavated. They're putting a huge tunnel down into that one.

A lot of these ancient things look like some of the early science fiction movies, where they were trying to presume what the future was like, but way off from what happened. We advanced very rapidly.

My grandparents came out in covered wagons. So there's a tremendous advance in technology. You see a very definite change in the technology.

So the early stuff, the low stuff, that's down underneath two or three other layers of civilization, is very ancient, seemingly very ancient civilization, probably where they would have used these gear-driven navigation instruments. But the navigation instruments, the gears, the gear ratios, were all set up for this galaxy.

David: So what are we going to find when we look at Antarctica if we get the truth?

Pete: You're going to find several layers, separate layers, of occupation. You're going to find several separate layers of what the exterior was like at the time that civilization was there.

Only the last layer was it really Antarctica. Prior to that, it was a tropical island. And part of that, it was part of a very much larger island. Probably good pieces of it were pieces of Atlantis that actually picked up and moved down there.

Because it's like there are several parts of Atlantis that we find in the ocean, parts were left behind. There were a lot of parts that were highly radioactive and are still radioactive, parts that were destroyed.

But down there, one of the things you're going to find is those people, in the beginning, the early people down at that low level, were all giants. And some of them, as much as I understand, as much as 37 feet tall.

David: Wow! Well, I hate to stop you there, **Pete**, but that's all the time we have for in this episode. I'm **David Wilcock**. This is "[Cosmic Disclosure](#)", and I thank you for watching.

Cosmic Disclosure: Three-Fingered Technology with Pete

Peterson

Season 7, Episode 31

David Wilcock: All right. Welcome back to another episode of "[Cosmic Disclosure](#)". I'm your host, **David Wilcock**, and I'm here with our special guest, **Pete Peterson**. **Pete**, thanks for being here.

Pete Peterson: Thank you. Thank you.

David: We had been talking about crashes in Antarctica, and you had mentioned that, at the deepest level, there's one that landed on what's like a continental surface with tropical type of plants. And then you said that you had a lot more experience with a second crash.

Now one of the things that I find really fascinating in what you've been telling us, is that there was a set

of controls for beings that had three long fingers. So there's a lot of really interesting connections being made here.

And we were also talking about the mathematics of base three and the idea that, perhaps, we were given five fingers to confuse us away from this ideal math.

What would be the practical application of this base three mathematics that you say your friend has discovered?

If we start using that, what are some of the technological breakthroughs that we might have, or scientific breakthroughs that we might have?

Pete: What would be the proximate result, in the very beginning, probably half the mathematicians in the world would violently protest against it. And the other half would see it immediately.

It can easily be seen because he's broken it down into a series of charts, of charting numbers, and with different colors for the different digits and the different, say, points.

And then we'd try to say, 'Well, here are all the things that this makes possible'.

We can't even begin to imagine maybe 1% of the things that it'll make possible. It's so totally changes our representational viewpoint of the universe. Mathematics is a language.

David: Okay.

Pete: It's a way that we can talk about numerical things. And it's THE language of science. It's how we talk about almost all the things we do in science, even biological things and so forth.

Every form of engineering we have will change. Things that we couldn't ever do will become instantaneously doable by children.

David: Are there any other examples, that you know of, of beings with three fingers? You mentioned that this craft had sockets for three fingers.

Pete: Almost all the ancient beings have three fingers.

David: Really?

Pete: The ones that we have samples of.

David: Really?

Pete: I don't know, except very recently, of any alien craft that we recovered that didn't have three-finger control.

David: That didn't have?

Pete: Didn't have.

David: Really?

Pete: We don't have joysticks. The movement of the hand, wrist and hand, and fingers . . . and like I said, almost all the aliens have very, very similar apparatus. It's just that most of them have three fingers because it's much more . . . it's more than enough, or it's exactly enough.

And it's easier to deal with. It's easier to compute in your head for three fingers.

David: Some of the people watching this are going to say that intelligent life could not develop with three fingers because conventional anthropology believes that once we got the opposable thumb and could grasp and hold, that's once we were able to do toolmaking and develop intelligence.

Pete: They're absolutely correct, except you have two opposable fingers instead of just one – twice as much you can accomplish.

David: Really? So each of the fingers on the sides acts like a thumb.

Pete: Like a thumb.

David: Hm.

Pete: And in many of them, they go in like a thumb. I mean, they go in from the side. They're not three fingers like that. [**Pete** holds up three middle fingers.]

David: Right.

Pete: It's three fingers like that. [**Pete** holds up his thumb and index finger on one hand and positions the thumb of his other hand next to the index finger.]

David: Hm. Interesting. Could you tell us a little bit more about what was found in that second level, that second layer in Antarctica?

Pete: The control of exterior surfaces as if they were living surfaces and you were giving them commands . . .

David: Explain.

Pete: . . . to change the aerodynamics.

David: How could you give them commands?

Pete: Mentally. But you can also . . . In the beginning, it was with these control systems. The newer ones are done mostly mentally.

David: Wow! Are there any of these three-fingered beings still around today?

Pete: Most of them.

David: Most of them? Okay.

Pete: Right.

David: Visiting us?

Pete: Ha! We're kind of the least people on Earth . . . in the universe that they would visit. What do we have to offer?

Well, I'll tell you what we have to offer. Why are they interested in us?

We have Ormus, which is another type of gold, which allows you to live for many, many years. [It] extends the life of the flexibility of the regeneration of the nervous system and the telomeres.

It's what Solomon's Mines were all about – Solomon with his many, many gold mines. He didn't mine yellow gold. He mined white gold.

David: Hm.

Pete: And he sold it for very high prices to all the leaders of the world.

David: So you're saying there's something about the Earth that makes Ormus in greater amounts than might be available on other planets?

Pete: No. There's something here that we have a greater concentration of gold.

David: Ah.

Pete: Most of the space exploration was for finding Ormus or manna, another word for a very similar type of thing, but it uses Ormus, and the principles by which Ormus functions.

David: So when we go back to the cuneiform tablets, the Sumerian texts, most of the conventional scholarship on that now is in agreement that these Anunnaki were some type of extraterrestrials and that they specifically were coming to Earth to steal our gold.

Do you have any comments on that?

Pete: We, as a race, exist only because we were designed to be gold miners. That's why we exist.

We were a genetically-manipulated cross-breed of the Anunnaki and . . . I'll give you an example, which is easy to tell.

I think we have about 92% of the same DNA as the chimpanzee.

David: Chimpanzee DNA is 98.8% similar to human DNA.

Pete: Yep. And very early people were not fair of look and bred by the Anunnaki. Ha, ha. They bred a lot more into us.

And that's why a lot of the aliens . . . I mean, you know, we're bipedal. We have hands, We have fingers. We have two ears, two eyes, two nostrils, one mouth.

And we look at a good part of the aliens and they're exactly the same.

David: Right. So, just to be clear, are you saying that the Anunnaki bred us out of something like a chimpanzee and then mixed their own DNA with it?

Pete: We were somehow bred into what had the DNA . . . similar, obviously very similar, to chimpanzee. It gave us the ability to squat down, get in small . . . Gold usually appears in very small cracks.

You follow the crack up through the Earth. It came up with water and then set up.

And remember that a lot of gold is found in quartz. Most gold is found in a quartz deposit.

David: Hm.

Pete: Quartz is piezoelectric. If you squeeze it, it produces electricity.

David: Right.

Pete: The electricity would do the conversion process. The movement of the Earth would make the electricity that did the conversion process. That's why we find yellow gold there.

David: Do you think there is a relationship between the Anunnaki that we're talking about just now and the crashes that you personally saw in Antarctica?

Pete: Well, I think there is because the Anunnaki were the ones who . . . Imagine a mining claim. Well, the Anunnaki were the first people to find that there was a lot of gold on Earth.

David: Hm.

Pete: So they had a certain claim and were given a certain task by their task masters, who are, very probably, Draconian.

David: Are these three-fingered people still on Earth with us today?

Pete: When I was reverse engineering the controls, I had three-fingered people helping me.

David: Really? What would they look like in terms of their head and face?

Pete: Well, there's a difference in the eye structure because of the inner eye fold between Orientals and Anglos. So you have that kind of difference. It's different.

Lesser nose and different nostrils.

Their mouths are round, kind of like an octopus sucker. I mean, they're more round than ours.

Their food is produced by them eating food and excreting an excretion that comes off their skin. And they scrape it off and eat it.

David: Hm. Is there anything about the head that we should know about?

Pete: Well, it's different, but it's very much the same.

David: What's the color of the skin of these beings that you personally interacted with?

Pete: Well, they are differing colors. I've seen them look almost like aluminum. And I'm not sure but what they might not be, you know, might be aluminum. They might be clones, because they tend to clone these people.

And they are clones, by the way. This is why their whole feeding system works differently than ours does.

David: Hm.

Pete: They're actually like robots, but they're more biological than non-biological.

David: Hm.

Pete: I have kind of clandestinely measured the electric fields to kind of get some information, and I can't find any different . . . much different than the human electric field.

David: Are there any known places on Earth where these people or creatures might have been?

Pete: Yep. Arctica, Antarctica, Alaska, Canada. Most people don't know, but the Yukon and the Northwest Territory are not part of Canada. They're owned by the . . . whoever the sovereign of England is. They're directly . . . They're privately owned.

But that's where most of the gold is found. Surprise, surprise.

David: Ha, ha.

Pete: Ha, ha.

David: Are they working on the surface or underground?

Pete: No, most of them work underground. And the reason was, because when they came here, we were in the same part of the 29,000 year solar cycle that we're in now. And the Sun's emitting X-rays like it was an X-ray machine.

David: Ah!

Pete: So they were evidently sensitive to those and are working underground.

David: Hm. About how many of these people do you think are on Earth right now, or in Earth, if you had to estimate?

Pete: I couldn't even begin to estimate, but I believe I know of some of the places, and of those that I know of, I'd say probably 350,000.

David: Wow!

Pete: I think there's probably that many in Antarctica. Just a guess.

David: Are these people using a language to communicate or do they speak more telepathically?

Pete: Well, most of them are more telepathic if they're older, but the younger ones and/or the cloned ones, they can . . . I've watched one of them learn to speak English with an accent that talks about "eatin' grits for breakfast", in three to four days from arrival from wherever they come from.

David: Wow! Are there any of these beings in South America?

Pete: South America is one of the first places they were. All the Indians down there have, if you look at their outfits, they all have things like kachinas. They all have serpents. Serpents are big, which would be the Dracos, or parts of the Dracos.

Some of the Dracos are the nicest people you'd ever want to meet – ethical, moral, as we would judge, etc., etc. And some are pretty nasty.

David: You had said that you feel that the Draconians were in some way controlling or working with the Anunnaki, so could you define what you mean by Draconians so that we know we're on the same page here? And then explain the relationship between Draconians and Anunnaki that are more human looking.

Pete: Well, they're different. Some of them look almost human, but if you want to know what Draconians look like, go back to any ancient society and look at their dragon people.

They seem to be the older civilization that we know of, at all. They came from . . . Very few Draconians, naturally, were in the Milky Way.

The Milky Way is kind of a holding facility for people who are going to be growing the things that are required to keep the DNA of ancient societies working.

David: Really?

Pete: Yeah.

David: That's a very provocative statement.

Pete: That was our primary purpose, as best I can tell.

David: For the whole Milky Way?

Pete: The whole Milky Way.

David: It's sort of like a big genetic farm.

Pete: Yes.

David: Hm.

Pete: But a farm for other things, too – a farm for gold, which is required for Ormus, which is required to keep the telomeres working and keep the neural system flexible and the brain multiplying and getting greater and so forth.

It was responsible for all the ancients that we know of in our own history who lived to be 200, 300 – you know, Methuselah.

David: So could you explain for us if anybody got into the second ship? Did you ever get to see the interior or hear about what was inside?

Pete: I got a quick walk-through.

David: Really? Wow!

Pete: The reason was, I have done a lot of interesting work on alien control systems. It's one of my small areas of expertise or large areas of expertise.

David: Uh-huh.

Pete: So I look at the control systems, and, you know, I can figure them out. I can say, “Oh, I know what that's for. I know what that's for.” I've had enough experience with it. I just know.

David: All right. Let me ask you some questions that might seem basic, but it will help us.

First of all, how high was the ceiling once you got inside?

Pete: I'd say it was probably, in areas, maybe three feet, three and a half, and in other areas, it was probably as much as six and a half or seven feet.

David: So it's kind of a crouchy situation.

Pete: Well, it's . . . Remember, it's saucer-shaped. It's going to taper down at the edges and get higher in the middle.

David: So what did it look like inside? What did you see?

Pete: Well, I saw a central core. That's normal on saucers because of how the ones I know of work that way. They work with a huge shaft. You could call it like a flywheel down below the deck and then an upper deck.

And then you find a lot of them have like a – I don't know what you'd say – maybe a control tower.

They have . . . If they have windows that are up on a top, an upper thing, where you'd stand up and look out the windows.

David: Ah.

Pete: The piloting is not done with a window, it's done with a . . . like we do it today. It's done from a computer screen, a screen. I'm not saying a computer screen. They have very organic kind of things, like they can make it look just like you're looking right out . . . like you were sitting right out in the open in front of it.

David: What were the surfaces predominantly like? Were they metallic, or did they have a color?

Pete: I would say they were some form of coated plastic or coated metal. There was a coating.

David: What was the most surprising thing about it to you?

Pete: From the ones I'd seen, there was a lot of technological changes, which is to be expected. I mean, look at our aircraft.

Each generation . . . The ones we have flying now were started 20 years ago in design.

David: Right. You said that these craft were piloted by beings with three fingers and that they've appeared all over the Earth.

Pete: Right.

David: Does it appear that that population came from this ship originally, that that was their original . . .?

Pete: Oh, no, no. Not at all.

David: Oh!

Pete: Not at all.

David: Okay.

Pete: No, I know of probably five or six races that all have three fingers. I would say, probably most of the aliens have three.

David: Hm! You had told me before about something with a craft in Antarctica where there were panels that gave off their own light.

Pete: Right.

David: Could you talk about that for me?

Pete: Yeah, those are on the last two ships.

David: Okay.

Pete: It's a material much like phosphorus, or phosphorus. You know, we have these little things that you can pin on your ceiling that look like stars and moons and galaxies . . . kids trying to . . .

David: Right. Glow in the dark.

Pete: – glows in the dark – and shine lights on them. They glow for a little bit and then they die out rather rapidly.

There's a material that's being made in Australia right now that you put it out and give it about 30~45 minutes of sunlight exposure, and it'll give off enough light to see and, at least for a day, to read by before it runs down.

Well, the alien lights are absolutely much the same, except they light them up with ultraviolet or infrared LEDs, some type of photo . . . what we would call alien LEDs.

David: So you're saying that the interior of one of these ships had a material that they would light with some kind of LEDs, and then once they did, it would glow for a while on its own.

Pete: Well, it would . . . What they would do is . . . The lights flicker at, say, 1,000 times a second . . .

David: Okay.

Pete: . . . but they may only turn on every 10 cycles, or 20, or 50 cycles, depending on the outside light and the ambient light, and where they are in that programming pattern of the lights.

It looks like the whole ceiling in the control rooms, which is where I mostly have seen, all the ceilings made of . . . They're coated with this material. You can paint it on.

David: So let's talk about the third crash. You said that there were three layers of crashes there. What was the third uppermost layer?

Pete: Well, these are the ones I know about. There's three that I know about.

David: Okay.

Pete: That was quite recent. It was exposed to the outside. It was picked up by satellite photographs. It was a disk. It was at an angle, about maybe a 15° or 20° angle.

David: Okay.

Pete: And it obviously had gotten caught up with the control navigation systems, which we're using, . . . the electromagnetic . . . there's an electromagnetic field, and it got . . . where it got too close to where it goes straight into the ground and, I guess, it slid off.

I mean, there are quite a few electromagnetic things on the craft to help it stabilize, and it picks up the field and then reacts with the electromagnetic field.

David: What was the size of the ship like compared to the other two that were there?

Pete: It was an intermediate size. It wasn't that large, I'd say, maybe, 350 feet, 400 feet in diameter.

David: Hm. And what was the technology like compared to anything else you're aware of?

Pete: Upgraded, considerably upgraded.

David: Is there anything unusual about the third crash?

Pete: Well, the third craft had a lot of living people.

David: Really?

Pete: I don't know that they lasted very long because I know some of them didn't. I know some of them were shot. I know some of them were used for experiments.

David: You mean we found living people inside it?

Pete: They'd been living there for years.

David: Okay.

Pete: I mean, they were growing their own food. They were synthesizing their own food.

David: What were the people . . . What did they look like for this? You said they'd colonized basically once they got there.

Pete: I think this group had people that had been here for a long time that came from somewhere else onto this craft. Some looked like Dracos. Some looked like both the metallic and the non-metallic people with the large eyes.

David: Uh-huh. You're starting to describe what sounds like different types of ETs, but you're saying there's one craft. So could you please specify?

Pete: The one craft was used as a lifeboat.

David: Okay. And there were different types of beings inside?

Pete: There were 15 different species of beings there.

David: Really?

Pete: These are the ones I know the best.

David: Okay. And they were all inside this craft?

Pete: Well, they were inside of various compartments in the craft – different compartments, different atmosphere, different gravities.

And it looked like that some of them had been there for a long, long, long time.

David: When did the U.S. government find this craft?

Pete: I think they probably found it, maybe, about 1941 or 1942.

David: Really? Like World War II?

Pete: Yeah. Oh, yeah. Before the end of World War II.

David: You said that some of these people were killed when we first got there?

Pete: My understanding is that some of them were shot by guards. Some of them decided they didn't want to be restricted to this craft.

There were some of them that breathed our atmosphere fine. They went out for a walk, and then they got shot, because they didn't know the protocol, because they'd never been out there. The guards lied. You know, they were just typical human beings.

David: So the Germans seem to have gotten to Antarctica pretty early, maybe as early as 1938~1939.

Pete: Oh, they had huge [number of] people there.

David: Do you think that the Germans might have found this craft first since you say it's kind of on the surface?

Pete: I'm certain they found it first. I mean, I don't know that for a fact, but I can't imagine how they'd miss it.

David: Okay.

Pete: And, of course, they were way into that, and they were in communication with four or five or six different groups of aliens at the time.

David: So did the Germans do the shooting, or did the Americans do the shooting?

Pete: I have no idea. I would certainly think it was the Germans.

David: This craft . . . It sounds like they might have also gotten down to the other craft if you're saying they landed in the same proximate area. Were they trying to get to those other older craft?

Pete: Yes, the last one was trying to rescue anybody that was still there.

David: Oh!

Pete: And the people in the older craft were in a stasis-type of situation, but it had long since run out of power.

David: Hm. Were the people in the newer craft able to actually use any of the resources or activate any of the power systems?

Pete: They used a lot of the resources.

David: Of the older craft?

Pete: Of one of them, not the bottom one.

David: The middle one?

Pete: The middle one.

David: Okay. So you're saying then that they had created some kind of colony where they're in their original ship. They're also able to access the second ship. And that they had lived there for quite some time as colonists, if you will.

Pete: Some of them had, yes, the ones that lived on.

David: Did they have any ability to travel around the Earth? Did they have any craft they could fly in?

Pete: I don't think that they . . . If they did, they didn't really use them because they didn't want to be discovered. And I don't know that they did. I don't know that they had anything that was running.

David: But these different groups of people – you said there was 15 different types – they'd all learned to get along with each other?

Pete: About as well as 15 different groups from this planet would get along with each other.

David: Well, you had mentioned that some of them look kind of like what we would call Greys.

Pete: Yes.

David: Others maybe look more human. How divergent were these 15 different types?

Pete: Well, you had the ones that were from insects.

David: Hm.

Pete: You had ones that were from underwater or under liquid beings. You had some that were Dracos. There are good and bad Dracos in a one-thirds, two-thirds kind of thing.

David: One-third good, two-thirds bad?

Pete: Yeah, of those that we know of.

David: Okay. So how would you have a predatory species like the Draco able to co-exist with other types of extraterrestrials? That seems hard to understand.

Pete: They don't.

David: Oh!

Pete: I said there are good and bad Dracos.

David: Okay.

Pete: A good Draco's not a problem, in fact, even less than not a problem. They're like the priests and the ministers and try to do good and so forth.

David: Hm!

Pete: Most of them are that way. There are a few of them that are a little snotty.

David: Well, then I would assume that the Dracos that were in this craft were the good ones?

Pete: Absolutely. The rest of them, they got rid of immediately.

David: Ha, ha. Okay.

Pete: Ha, ha. They don't get along well.

David: Did they allow any of us to go in there and work with them or live with them?

Pete: Well, yeah. A good part of the main staff and crew are humans.

David: Hm.

Pete: I mean, we are producing, helping them get raw materials and learning from them. It's a tit for tat.

You know, we're learning a lot of technology. We have technology right now that I would say is a good 300 years in advance of anything that anybody that lives above the ground knows about.

David: Sure.

Pete: Remember, we have lots and lots and lots of people living below the ground.

David: Are there any other significant things that have happened in Antarctica that you know about?

Pete: Well, I have a conjecture that the reason we went there is because we knew about what was going on with the Germans.

On the other hand, the ostensible reason we went there is to see what all we could do in the field of early, early, early field of semi-conductors, biological research. What could you do in this particular – and they called it like atmosphere. In other words, how much electromagnetic waves, how much gravitic waves, how much magnetic structure there was.

The magnetic fields were oriented 90° different than they are on most of the rest of the Earth.

David: Uh-huh.

Pete: And each one of those things we found, had very, very great import for synthesizing metal structures, for synthesizing chemical structures – fluids, both fluids and solids – for working with metals, for doing research work on magnetism, and finding out new things about survival in that particular part of the world because we knew that probably two-thirds of the world's leftover – left from our mining and so forth; those metals and those compounds and those rare Earth and stuff – all exist on these two continents.

David: All right. Well, that's all the time we have for in this episode with **Pete** Peterson. And **Pete**, I want to thank you for being on this program.

Pete: Well, I appreciate that.

David: Thank you. And I want to thank you for watching. I'm [David Wilcock](#) here with **Pete** Peterson, and this is "[Cosmic Disclosure](#)". We'll see you next time.

Cosmic Disclosure: The Grand Experiment

Season 7, Episode 32

David Wilcock: All right. Welcome back to “[Cosmic Disclosure](#)”. I'm your host, **David Wilcock**. I'm here with **Corey Goode**, and in this episode, we're going to get into the Grand Experiment.

This is something that is of particular interest to me, and I'm sure to many of you watching this program, because this Experiment affects people who are human but may not fit in and may in fact have ET souls.

So here for more information is **Corey Goode**. **Corey**, welcome back to the show.

Corey Goode: Thank you.

David: So we've talked about the idea that there was a Super Earth in our Solar System that exploded 500,000 years ago, and that it deactivated some sort of protective grid around our own Solar System and neighboring systems as well.

And you said that shortly after this, a bunch of groups of ETs came in. And could you tell us a little bit about them just to recap? Who are they, and what do they want?

Corey: Yes, they've been referred to as this Genetic Farmer race. And they've been on some sort of a mandate throughout the galaxy to spread advanced life, and to monitor and assist the development of that life, as well as the spiritual development of that life.

David: Could you define “advanced life?”

Corey: Advanced life would be, I guess, like a human being.

David: Okay. So at what point did you become aware of this existing?

Corey: I first became aware of this program when I was around the age of 13, and I was in these MILAB . . . what we're calling the MILAB programs.

David: Okay.

Corey: Once I had been put through the process of receiving the full dose of the serum that they were giving me for intuitive empaths, I was also about at the end of the training, and they wanted to have me out in the field.

So around age 13, they took me to . . . which we've done an episode about . . . they took me to this Super Federation base outside of Jupiter.

And I've described before how when we would fly into this temporal anomaly, that you ended up in a giant, like, a bubble in space, that you couldn't see stars. It was just pitch black.

And the space station was sitting right there in the middle, and you would see craft going to and from, from different races. And they were coming to have a meeting.

David: So why would ETs doing this be interested in a 13-year-old kid?

Corey: They had no interest in me whatsoever. I was there as one of three IE supports. They usually would have three intuitive empaths with them to help triangulate any type of deception, danger, anything like that.

David: Okay.

Corey: And as I've described before, they brought us into the main meeting hall, and we sat in sort of a horseshoe fashion in a delegate seat. And at that point, they were giving us smart-glass pads to keep ourselves busy.

And I was starting to read information in those about the group that I was there to support and the different genetic programs that they were involved in.

And that's when I found out that there were 22 different programs.

David: Were you there to support an ET group? Is that what you were involved in?

Corey: No, I was there to support the Earth delegation, but I was there to monitor everyone other than the Earth delegation.

David: So even though this Earth delegation is not elected, on some level, they represent us for this council?

Corey: Right. They rotate in. The seat rotates to different people on Earth.

David: And what would be our role in these negotiations? What are we fighting for? What do we want? Why are we there?

Corey: We don't have a role. It's just an observation. We're just there to observe. And that was granted fairly recently, from what I'm told.

David: Did they ever intend for this information to be known to the general public, or do they want it to stay strictly classified?

Corey: Classified.

David: The beings that you saw in this Super Federation, how extraterrestrial would they look to us?

Corey: Well, there were 60 plus different groups. So some of them looked very similar to us in size . . . not in size but in configuration – you know, humanoid.

But a lot of them were very human-looking. They just had slightly different skin colors. I mean, they looked slightly different, but they looked fairly human.

There were some that were obviously a part of this Pre-Adamite group, the more ancient one. They were taller, and they had the elongated skulls.

There was even the ones that I had talked about in the previous episode we did, with green skin and black hair.

David: Do we know how local they are in terms of positions in our galaxy? Do they come from all over the galaxy, or is it more of a local area?

Corey: No, they come from all over the galaxy. Our local star cluster was once protected by a barrier, as we've discussed, by the Ancient Builder Race.

David: Right.

Corey: And once that was brought down from the inside by some of the inhabitants, these groups finally had access to all of this new, rich genetic stock. It was a very exciting time for them. They had not had access.

The only genetic programming that had gone on inside this bubble, if you wish, were groups that had become advanced themselves genetically and were traveling around within that local star cluster doing genetic experiments. And that had been going on for a billion years.

David: Just to review something that I believe you said before, are the people that evolve on planets in our local star cluster going to look more like us in general?

Corey: For the most part, they look very similar. Yes.

David: Okay.

Corey: There are different types that aren't as mammalian-looking.

David: It seems to me that we're pretty clear now that the Secret Space Program was being run by the Cabal, that there were some very negative aspects to it.

The term "Genetic Farmer", to me, sounds kind of derogatory. And I'm wondering if perhaps what they're doing might be actually more benevolent for human life on Earth than how the Cabal-run Secret Space Program might have been seeing it at that time.

Corey: When you are the petri dish, or the rat in the cage, your perspective is a little bit different than if you're the one wearing the white coat.

David: But wouldn't you say that the basic idea of what they're up to . . . People hear the term "Genetic Farmer", they might think that this is some kind of slave mill in which human genetics are being used for food or something like that.

Whereas what you've described before sounds more like an ascension plan, that they're trying to help us.

Corey: Right. It is a spiritual and genetic plan, or program of evolution, that is working in concert with the cosmic changes occurring in different regions.

These cosmic . . . In different parts of the galaxy, these energetic influxes have occurred at different times and in slightly different ways. And they're working with the local populations in concert with those cosmic changes to enhance their DNA and to enhance their consciousness.

David: I was recently going through the Hindu sacred texts using a search engine, and I found approximately . . . and it's not exactly clear if they're all individual or not, but I found approximately 188 references to the Solar Flash.

Everybody talks about this Solar Flash, and you have groups that are Reptilian groups called the Rakshasas. You have clearly groups like Krishna that have blue skin but are human-looking.

There's a variety of groups that were on Earth at that time. And in these books, the Vedas, they talk about the Solar Flash as if everybody knows that this is going to happen. The Sun is going to give off this big flash at the end of the age, and that there is some kind of transformation of life on Earth.

So do you think that there is some relationship between the Genetic Farmers and what's going on in the Hindu ancient texts?

Corey: Yes, because this flash they're talking about is just a byproduct of these cosmic changes that are occurring, these energetic changes. So yeah, it's a direct tie-in.

David: It's interesting, because it's like reading other people's mail. Everybody takes it for granted. They all know this is going to happen. There's no question that it happens.

Corey: It's happened before.

David: Yeah, so it's something they consider just to be a basic fact, like we would say that the color red is on a stop sign. Same thing.

So if they are trying to promote our Ascension, what is the difference for us when this Solar Flash would occur as opposed to if we were just out in the boondocks and nobody had ever done any of these experiments on us? What's the difference?

Corey: Well, I'd like to think that there's some sort of structure to the cosmos. I think that most likely you would still be advancing but at a much, much slower rate. This is like putting turbo speed on the Ascension process.

David: It's almost like the analogy of the jack-in-the-box, where we're spring-loaded and POW! Something happens when the Solar Flash takes place.

Corey: Right.

David: What was the history of intelligent life on Earth, if any, prior to the catastrophe of half a million years ago where the Super Earth blew up? Was there any human life or intelligent life on Earth before that?

Corey: Well, interestingly enough, this Reptilian or Saurian group that has been in conflict with humanity for so long, claims that they originally were stewards of the Earth, and that they had their own experiment going on here, that some of these races that now have a mammalian experiment going on had sterilized their experiment, and that in doing so, they had lost three races.

David: Hm. Three different intelligent species?

Corey: They said there were three lost races because of this cleansing that took place. So that's one of the claims made by the Reptilians that I have not had verified.

David: The insider, Bruce, who gave me a lot of the information for “Ascension Mysteries”, said that the prevailing opinion within his insider click now is that the asteroid, or whatever it was that destroyed the dinosaurs, was deliberately steered in, and that the Moon was placed in its current position at that time to jump-start more of a mammalian cycle for the Earth by giving us seasons that we wouldn't have had without it.

Corey: Yeah, interestingly enough, my recent contacts with some of these airmen that escort Sigmund, they told me that I had gotten the dates wrong.

They said, according to their information, this Super Earth blew up 500 million years ago, and that it was 60 or so million years ago that the Moon came into orbit and that a lot of stuff . . . and that also they were telling me that it was really strange, but they were trying to push the dates out much further.

David: Well, my own research would suggest that they might have been disinforming you for some reason . . .

Corey: Yeah, yeah.

David: . . . because I've had multiple individuals say the same dates. And the 500,000-year-old date is precisely in the Law of One.

Corey: Right. And this is after Sigmund was missing, and they were asking me about his whereabouts. And so, yeah, there's a lot of stuff that's been kind of weird since then.

David: Do we know anything about what these three Reptilian races would have looked like or where did they go?

Corey: Nothing. Possibly, because the Raptor group, it is postulated that they are remnants of the dinosaur race that escaped under Earth, underground, and they escaped the cataclysm. So I don't know if they could have been one race that survived and three more are missing, but it's interesting to think about.

David: Hm. So I know we covered the Raptors before, but not everybody is going to have seen all episodes. So could you tell us a little bit more about them? This is a very strange thing, obviously.

Corey: And I found out since then that they have all different sizes and types.

David: Oh, really?



Corey: Right. And the ones that we see the most have feathered plumes on the back of their necks like birds. They look like a mix between a dinosaur and a bird. They've got really jerky bird-like movements.

The opening to where they are is somewhere in the jungles of South America. And they've been known to come out and hunt at night.

Now, this is information I've been given more recently second-hand. It's not anything I read on the glass pads.

David: Do they make speech? Can they make speech sounds? Or how do they communicate?

Corey: They communicate telepathically with each other.

David: Oh, so they don't actually speak.

Corey: Well, they make noises. They have all different types, they . . . just like birds. They have nonverbal communications of different types.

But, yeah, they do not have a voice box. They do not have lips or a tongue, or the gene that everyone who has speech on the Earth has – I doubt very seriously. But they are high intelligence and are pretty ferocious.

David: Are they technological in any sense, or are they just basically a primitive species?

Corey: They're pretty primitive technologically.

David: Are you aware of any technology that they have?

Corey: Just basic . . . not high technology. Just basic technology.

David: What would be a basic technology?

Corey: Well, you know, like using sticks and rocks or putting things together. They're not super advanced.

David: Okay. So we have what appears to be a diabolical type of Reptilian race that was growing out of the dinosaurs on Earth. Somebody else comes in and decides that that needs to be sterilized and

cleansed. Do the Reptilian groups believe that they still are in control, and they have land and title rights to this planet as a result of thinking that they were here first?

Corey: Yes, that is one of their claims.

David: Okay. So it looks like what we're seeing, if this did in fact happen, is that these Genetic Farmer groups are actually terraforming, that they're able to remodel an entire planet based upon a certain desired outcome. Would you say that's true?

Corey: Yes, that's part of the Grand Experiment.

David: And if we've talked about the Moon – we had **William Tompkins** say this as well – having just a massive amount of internal structure, is it possible that the Moon could be transporting, literally, an entire biosphere from one planet to another inside of itself as part of this terraforming?

Corey: Well, that is one of the theories, that it's that ancient.

David: Okay. So if the Genetic Farmers are actively pursuing this type of a strategy, it seems like it's not just about creating life as we see it today. We are in the middle of something. We are not the end of something. Would you say that's true?

Corey: Right. Yeah, we're pretty far along in the Experiment.

David: Oh, we are?

Corey: I would say so. We're obviously about to reach some sort of a crescendo, so we'd better be a pretty good way into the Experiment.

David: Would you speculate that the Experiment would conclude fairly soon after the Solar Flash, that whatever they get out of that is the outcome?

Corey: It won't conclude. It'll just change – go into a new phase.

David: Okay. So this could actually go on for, in our terms, quite some time.

Corey: It'll go on until everything returns to Source or whatever happens at the end of time.

David: Would these Genetic Farmer groups acknowledge at some point that we would grow up enough to meet them and be aware of what had happened?

Corey: Definitely. The goal of these programs is to get each planetary sphere and the advanced beings on it to a point of self-management. At a certain point, we will be technologically, spiritually evolved enough to where we will start managing our own genetics and the pace of which we want them to evolve. That is the goal.

They want to get everyone to that point. And at that point, you become a part of this Grand Confederation.

David: You've talked before about the galactic slave trade, and the idea that whatever they've done here is so much more valuable than in many other places, that we are a highly desired abducted commodity, either as slaves or as a source of genetic material.

Why do you think this planet is so unique in terms of what they were able to accomplish with these programs?

Corey: Most likely because of its location in the local star cluster. It's right in the middle, right by a supergate, so beings are going to be able to come here easily from anywhere in our galaxy or other galaxies.

David: Do you have any specific information about the actual components of the genetic programs that these guys are running?

Corey: There is a genetic component. There is a spiritual component, and a related component, consciousness component. And the last component is one that we discussed, it's the cosmic component – all of these working in concert with each other to work in timing with the cosmic component.

David: Okay, that's interesting because when we talked about this before, you would basically just describe it as a genetic and spiritual component, and it's like a sliding scale between one or the other.

So now you're also saying that there's a consciousness component and a cosmic component as well as a genetic and spiritual.

Corey: Right.

David: So could you delineate what these four categories would represent?

Corey: Right. And we just had never gone this in depth.

David: Okay.

Corey: The genetic program is pretty obvious. They're harvesting genetics from other star systems, galaxies. And once they've gotten to a certain point that they think will be a good catalyst for a different species, they'll bring it to that planetary sphere and begin to genetically manipulate that species.

They have to stick to cosmic laws very strictly – the laws of free will.

David: Uh huh.

Corey: So one of the largest components of this program – and it took a long time to figure this out – was a lot of the people, if not most, that are being abducted and experimented on, they were incarnations of the soul group, I guess you would call them, of the beings that are doing the experiments.

So basically, let's just say like an Eban – they don't normally do that much experimentation on humans – but if they wanted to go down and ethically do experiments on humans, they would have a number of their people leave their bodies, go down, go into incarnation on Earth, and then be a part of the experiment and allowing themselves, in an agreement before they went in, to be genetically experimented on.

David: Are you saying that cosmic law requires you to do that in order to play around with these experiments?

Corey: The cosmic law requires the benevolent ones to do this type of thing.

David: Wow!

Corey: They learn how to skirt these cosmic laws very well without crossing them.

David: Hm. Okay. So you have a genetic component, and you indicated that they are harvesting genetics from another planet. What does that mean? That sounds pretty terrifying.

Corey: Well, they're getting genetic samples from beings that they have developed to a certain period. And there is a being over here that needs that same development. So to give them a turbo boost, they'll take those genes, transport them over to this group.

David: It's not like they're throwing a being in a blender and then just taking the tissue.

Corey: No.

David: This is a very technical process I assume?

Corey: At this current day, if you were to give a genetic sample, you're just going to spit in a cup or get a swab.

David: Right.

Corey: They don't have to put you in a blender.

David: So that's what you mean by "harvesting".

Corey: Right.

David: Okay. Then you also said there was a consciousness component to this. And could you explain what the consciousness component is and how that would differ from the spiritual component?

Corey: Yeah, the consciousness component is related to the spiritual component. The consciousness component is to have the target group, which would be us in this case, develop their consciousness on a schedule that matches the cosmic schedule that's about to occur. So it's all managed very carefully.

And consciousness grows at a certain rate that they have calculated, but they're enhancing it by coming in and giving us different, not just religions, but cultural things. You know, teaching us how to raise animals and all of that civilization kind of . . .

David: Yeah, this is interesting because it appears that if you look at this Atlantean catastrophe of 12,500 years ago, thereabouts, that in the aftermath, we have independent civilizations all over the Earth that seem to develop the technology of milling grain, metallurgy, plumbing, sewage, building technology, mathematics, time measurement, codified law.

You're saying that these Genetic Farmers are centrally involved in all that type of stuff?

Corey: Yes.

David: And it's because they're keeping us on a timeline?

Corey: Well, not necessarily a timeline, but keeping us on schedule for the Cosmic Event. And they want to enhance us much further through this genetic engineering and spiritual engineering process so that when this Event does occur, this Cosmic Event, that we are going to boost much further than we would if we developed naturally.

David: And it would appear that they are allowed to be “gods”, if you will, to show up in person with their craft and in their incarnate forms as they're going through these stages of a rebooting of civilization like this.

Corey: Yeah, if they're in the middle of a reboot, but for the most part, no. The positive ones try not to appear in the sky or around human beings or other beings, unless that is one of the catalysts that they're trying to use to have them grow in consciousness.

David: So if they want to teach us about alchemy, or metallurgy, or astrology, or something like this, and they don't want to appear, how would they be doing it?

Corey: Well, through leaders. They communicate with people telepathically. They give people ideas. They've done that with our scientists for a long time, seeded ideas and information to them subconsciously.

And the spiritual component is very much tied in with the consciousness component. That also has to do with these Genetic Farmers. They are incarnating as us to be a part of this Experiment, but many of them are karmically tied.

Because of the experiments that they've been doing, they can't go any further in their evolutionary process unless we come along with them.

So a lot of their agenda has to do with having us progress so THEY can.

David: Do they all have languages where the name of their group would be something that would be able to be encapsulated in the type of consonant and vowel sounds that we use in our own spoken language?

Corey: Some [names] we'd be able to pronounce.

David: Are there others that have anomalies in how they speak that would not be at all familiar to how we could talk?

Corey: Well, I mean, go to Swaziland or somewhere just here on Earth and you hear the difference in how they communicate – clicking and pops and stuff. So yeah, there's a wide range of ways that they communicate – different types of languages.

But there is . . . There does seem to be one standard language that they share, that they use.

David: I was sitting down with Graham Hancock for dinner at Contact in the Desert, and we talked about some similar subjects as this. And he reminded me that he wrote an entire book called “Supernatural” in which he discussed this idea that various indigenous cultures are making these cave paintings, and that that may actually be a far more sophisticated language, sort of like a hieroglyphic, that in some ways is tethered to a psychedelic consciousness, where the beings that they're drawing actually exist somewhere.

So I'm curious if any of the languages that these Genetic Farmers have may involve a type of written hieroglyphic that does have a psychic domain that it activates by looking at it in some way.

Corey: Yes. Yeah, there are a lot of pictographic languages that the non-terrestrials have that in them will evoke that type of response. In us, it may evoke a similar response. It just depends on whether you're close to them. There are a lot of variables there.

David: So we talked about four components total, and the fourth one was a cosmic component. So where does that fit in with what we're discussing?

Corey: Well, the cosmic component is that in each region of our galaxy, the way that the galaxy rotates, star systems and star clusters are moving into these high energetic gaseous areas that are a catalyst for this.

And they calculate how quickly you're moving into it. A lot of these energies they say have been hitting us since at least the 1930s, but they've been increasing, increasing.

So what they've been doing, the Genetic Farmer groups, is that they've been engineering humans genetically and also working on our consciousness and spirituality in a way to where when we get to the crescendo of this energy influx that we will be ready to make a turbo jump in changing densities, in changing consciousness, as opposed to if they hadn't have interfered, we would just be a slightly different version.

David: There's a lot of really interesting stuff in this Genetic Farmer subject for me, because the last time I ever used alcohol and drugs was on a Friday night. And I went to AA meetings starting on a Saturday.

And that same weekend, I believe on Sunday, I wrote this long essay about Earth. It was called "Earth as an Experiment."

And I was describing the idea that there were ETs that were setting all of this up of our lives on Earth as part of a grand spiritual experiment.

Do you think these Genetic Farmer groups show up as people?

Corey: Well, definitely. They incarnate as people, as human beings. So they will incarnate as a human being. And at the end of that lifetime, their people will come and retrieve that soul and add it back to their collective. They usually have a backup body for them.

In fact, in the programs, in the beginning, there was some confusion, because some of these beings were coming in that we weren't real familiar with and abducting people and returning their, basically, dead bodies.

And what finally occurred is that when we captured some of them and interrogated them, we found out that they were here retrieving some of their people who had died in crashes here thousands of years ago.

David: Hm.

Corey: And their people got caught up in the reincarnation cycle here on Earth. And what they had to do is locate their people, remove them and remove the souls and put the souls into another container,

and they would return the bodies. So they saw it as a rescue mission, and a lot of the people in the programs thought there was something more nefarious going on.

David: Yeah, that wouldn't sound as much like one of the benevolent groups as a group that's probably more just tinkering around but without so much of a spiritual focus.

Corey: Right, but from the perspective of this group, they're basically like "Star Trek Voyager" coming in to rescue some of their teammates that have been missing for 1,000 years or so.

So they have a completely different perspective on it.

David: So how much memory do these, as they're called in "The Law of One", the Wanderers . . . how much memory do these Wanderers have of who they really are once they become human?

Corey: They're basically a blank slate when they get here to keep them from violating the laws that they're trying to circumvent by incarnating here. So that's a part of circumventing those laws is to incarnate here as a blank slate.

David: What would allow one of these people to escape the reincarnation cycle? You said once they come in they have to reincarnate.

Corey: In our incarnation cycle, reincarnation cycle, for as much time as it takes them to, I guess, evolve out of it, which they can do a lot quicker since they've done it before, they're usually a species much more advanced than us, of course.

But also what can happen is they can be rescued. If they're not rescued, they're stuck here until they complete the cycle.

David: From what you're describing, it sounds like some people might interpret this as if they're getting into a soul trap by coming here.

Corey: Well, their soul DOES get trapped, but what occurs is that each planetary sphere has its own reincarnation cycle. And if they get caught up in it and don't have anyone to rescue them, then they're going to have to stay in it until they are able to get out through quick evolution.

David: In "The Law of One", it says that any Wanderer that engages in a consciously unloving act towards others gets caught up in this reincarnation cycle. That's actually stated in there.

I'm wondering if anything that you've heard personally would validate that idea.

Corey: I mean, the validation of that idea is basically the report that when these craft have crashed in the past, they've gotten stuck in our reincarnation cycle. So that would correlate.

David: Right. So let me ask you this. Are all of these various ET groups – you said there was 40 or 60 of them at various Super Federation meetings – are they all basically cooperating with each other and working for the same goal?

Corey: They're working for the same overall goal, and they're loosely cooperating with each other, and they have treaties and agreements, but they are not working in concert with each other.

A lot of these programs are competing programs as well. That's why they have kept their experiments separate from each other. And they've instilled religious things like, “Do not mix with other races”. They didn't want to pollute their experiment with another experiment.

David: Would they ever actually abduct someone outside of their own group for any reason?

Corey: Yeah. Often these groups, they keep tabs on each other's experiments. And oftentimes, they try to sabotage each other's experiments.

David: Hm.

Corey: What will happen is they will go and abduct an experiment, or a person that is an experiment from one group, and get the genetic information, do evaluations of their spiritual and consciousness level to keep tabs on how quickly their competitor's experiment is proceeding.

David: So you said that religion is one of the ways that these groups are partitioned. So are you basically saying that geographic regions with particular races and their own separate special spoken language, that those are all actually separate programs?

Corey: Well, yes. And the fact that these different races on Earth are found in different regions separated by oceans, usually, that is done on purpose to keep these experiments from intermingling and polluting one another.

And that's where a lot of the social programming, religious programming, has come in. You know,

“don't marry outside of your race” – a lot of instilling of racism to make it “us against them”.

They want us to self-manage on that level and not interbreed and mix with each other. That will pollute their experiments.

David: What would be the goal of them competing with each other like this? Is it about prestige?

Is there some sense of winning if one group proceeds faster or develops faster spiritually or technologically?

Corey: I don't think it's that type of competition. They want to see their agenda completed first.

And before all the treaties, a lot of these 22 different groups were battling with each other. When they first come into an area that has not been controlled by one of these Genetic Farmer groups, they have a whole routine of making claims, and there are skirmishes over claims.

So they go through this whole process, which usually ends in some sort of a treaty which they abide to until that experiment reaches the point of this cosmic portion of the program.

David: If you're saying that there are 22 different groups, and there are also up to 60 attendees of races, ...

Corey: 22 different programs.

David: Okay.

Corey: 60 attendees. And some of these attendees, there will be like five groups working on one genetic program together.

David: Okay. That's what I thought.

Corey: And then some of them will be working on more than one program. They'll be working on other programs that are not in competition with theirs.

David: So you could actually have one particular culture on Earth in a geographically isolated region that might have as many as five different ET groups that would be working with them, incarnating among them? This kind of thing?

Corey: Yeah, and some of them might be just taking the genetic component. Others might be appearing to certain people on the ground and giving them religious ideology. Some of them might just be appearing to give them a boost in civilization, technology for civilization.

So they work in concert with each other.

David: I'm curious about the population density of some of these groups on Earth, because it seems to me that someone might erroneously conclude that you would have only a few categories of these programs, given the fact that there's only a few major monotheistic religions.

But what I'm hearing is, just like in medieval Europe, you have countries that are separated by mountain ranges or water, etc.

You might have something that we would think of as a country that could be its own genetic program, not just that it's a race or it's one particular religion, per se.

Corey: Right, regions.

David: Okay. So there could actually be a number of different geographically diverse regions that have their own experiments running in some sense.

Corey: Right. And sometimes multiple experiments, if they coincide with each other.

David: Hm. So in “The Law of One”, people that have this type of heritage are called “Wanderers”. They're also frequently called “Starseeds”. And I would imagine that probably the majority of the people who watch our show would be ET souls, given what we know about them and how long I've been studying this, ever since 1996.

What would you say is a message that you could give to those people that might help them understand who they are, what they're doing here, and what their purpose might be?

Corey: Well, I guess the hardest thing for most of them to believe is that they agreed to come here and experience all of this. Remembering that you, on some level, agreed to experience all this is the best way to keep yourself grounded, I think.

David: What would be a spiritual guideline for those people in terms of understanding what their purpose is for being here?

Corey: Well, most of those people are drawn to those things already, to eating properly, to raising their vibration through the type of information they watch and bring in, and meditating, that kind of a thing - and also mingling with people that are birds of a feather, I guess you would say.

David: It seems to me that a lot of people really get trapped into what esoterics would call “victim consciousness”, this idea that they are being oppressed by something that is gargantuan and totally beyond their control. And a lot of people seem to “sign off” on personal responsibility and move into that very comfortable skin of the victim role.

What would you say, in light of people that would be prone to thinking that way because they're awakened to the truth, learning that they volunteered to do this, that they volunteered to be here?

Corey: Well, we're learning that maybe we're not victims after all. This victim mentality, maybe that's just another psyop. Maybe once we realize what we are and our true potential, we will feel empowered and not like victims anymore.

David: Hm. I like that. All right. Well, that's all the time we have for in this episode regarding the Grand Experiment. I hope you've enjoyed it. It's very fascinating to me with the history of being a Wanderer and awakening to that in 1996.

I'm [David Wilcock](#) here with **Corey Goode**. This is “[Cosmic Disclosure](#)”, and I thank you for watching.

[Cosmic Disclosure: David Adair Bio](#)

Season 8, Episode 1

[David Wilcock](#): All right. Welcome to “[Cosmic Disclosure](#)”. I'm your host, **[David Wilcock](#)**, and in this episode, we have a true special surprise for you, one of the original and probably the heaviest of the original Disclosure Project lineup from 1997, the most intense insider in that original meeting, **David Adair**.

So **David**, welcome to the show.

David Adair: Thank you. Glad to be here.

Wilcock: Tell us a little bit about . . . Where were you born, and what were some of your early childhood experiences that brought you into this bizarre arena?

Adair: Ha, ha, that's well-phrased. I was born in Welch, West Virginia in Number 10 Pocahontas Coalfields.



Kind of like Hunger Games, you've got different districts. I was Number 10 District.

Wilcock: Ha, ha.

Adair: And being relative, about three miles from where I was born is Coalwood, and that's where Homer Hickam of October Sky was born.

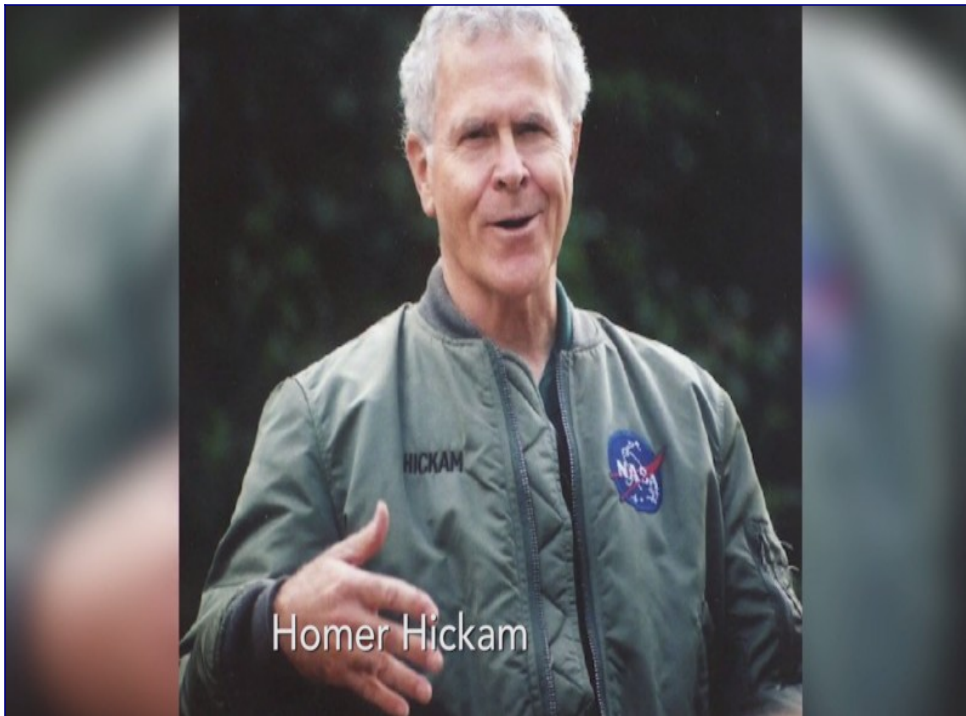

And he and I both agree there must have been something in the water in that place. But when . . . I knew there was something different about me.

My mother told me a story. She said I was only one and a half years old, and I was playing with a toy, and, of course, it's a model rocket, but it got caught between the refrigerator and the wall. And she didn't do anything, just watched me.

I was looking around, found a broom, could barely walk, get over there, sweep the rocket out, pick it up and take off.

And my mother said to my dad, Fred, "Fred, there's something not normal about that child."

Wilcock: Ha, ha.

Adair: "You know, he's already got tools and recognition. He's only one and a half."

Wilcock: Right.

Adair: So by the time I was seven, I would go to the local library, and boy, that's when it started. I started reading books in the 600 area, the science, really hard science, and then mathematics.

And this elderly librarian named Mrs. Hunt, she was watching me and said, “Are you reading those books?”

And I didn't mean to be smart, I said, “Well, there's no pictures in them.”

And she looks at it, and she goes, “Okay, let's see what you know.” So she grabs a book, just a random . . . I think it was one on singularities with black holes, and it's just really basic theorems, because around 1962, '63, there wasn't a whole lot on the subject.

Wilcock: Sure.

Adair: But you know, I read up on it, and I started explaining to her exactly how in detail it works with the mass star collapsing and graviton fields, event horizon, the opening.

Wilcock: Right.

Adair: And I was kind of drawing pictures for her, and she's watching me. And she said, “Man, you really do read this stuff.”

I said, “Yeah.”

Well, how many of these books have you read?

I said, “All of them.”

And she goes, “Why are you reading them now?”

“I'm going through them and correcting the mistakes in the books.”

And she just kind of stared at me, and I couldn't tell whether she believed me or not or just thought I was being smart.

But she said, “Tell you what. Would you like to get other books?”

I was like, “Oh, God. How can I?”

“Don't tell anyone, and I'll use resources and order them for you,” and she'd get stacks of them.

Wilcock: Wow!

Adair: And from other books, there'd be references to other books. So that's how I built my list, and I must have read about, oh, God, 1,800 books in a few years.

Wilcock: Wow!

Adair: And that was a real basis to work from at that point.

Wilcock: What ignited your passion the most in these 1,800 books or so that you read?

Adair: Space travel, pretty much so. Although I really liked all sciences – Earth science. I really liked Earth science, but space travel and propulsion, where it could go from then to maybe 100 years from now.

I just liked reading what people were trying to do or thinking of doing.

Wilcock: What was the most surprising mistake that you found in the books?

Adair: Their math. The math was off. I could tell right away. And there was a good reason for it. Nothing bad about the authors. They were just going on data that was coming off of satellites and probes and other research material, but we didn't have big computers then.

I could rework the math, extend it out and find where the errors are. And they really couldn't because they didn't have the support mechanism to do so. I don't know. I just could do it.

Wilcock: How did you start to apply this knowledge? Obviously, you're not just going to read books. You're going to want to do something with it, so how did you start to apply the knowledge?

Adair: That's a good question. There's a step that we can do, scientific method. You'll look at theoretical stuff, and then you move on to applied science.

Wilcock: Right.

Adair: So what does that mean in normal terms? It means that I was studying propulsion, so I started building rockets. And I started off by solid propellant, which I made my own solid rocket fuel just like Homer Hickam did.



There were no . . . The Estes kits didn't come out until later.

Wilcock: Right.

Adair: But they were just too slow and too primitive.

I mean 4,000 years, China with gunpowder.

And so I jumped to the cryogenic fluids, liquid hydrogen, liquid oxygen.

Then we got some power out of that.

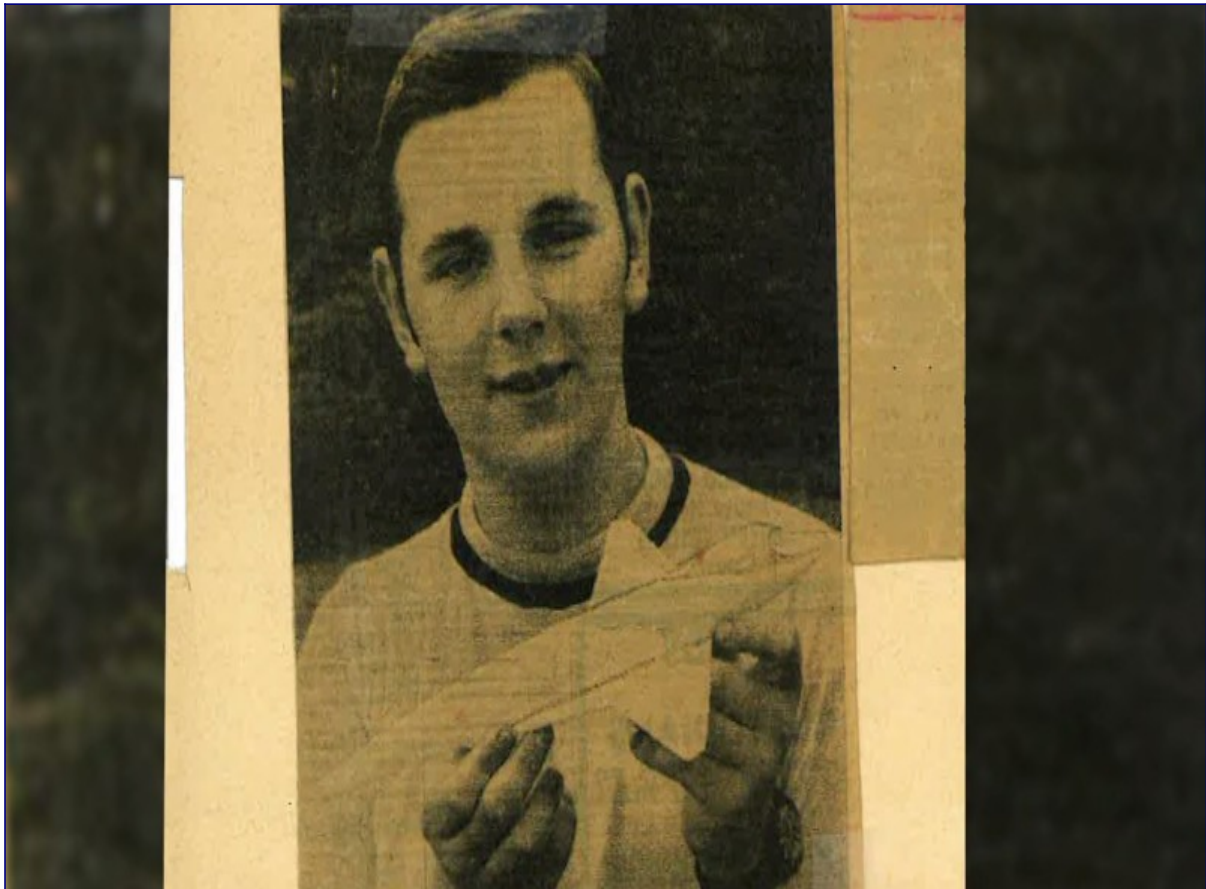

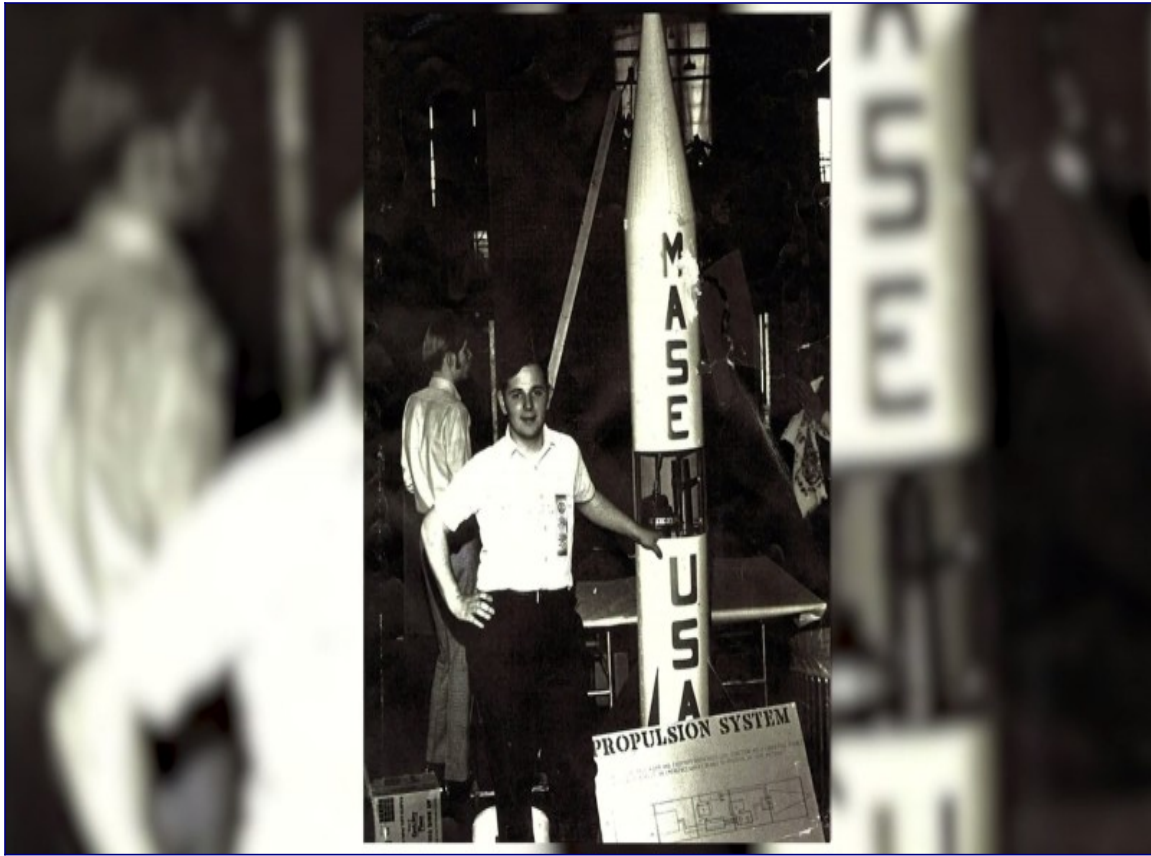

MOUNT VERNON

VERNON, OHIO, 42353 WEDNESDAY AFTERNOON, MARCH 31, 1971 — No. 76

Dave Adair builds 10-foot rocket

By HAL

David Adair, 17, has hopes of launching a 20-foot rocket using oxygen and hydrogen.

This is quite a contrast to the usual tin-like model rockets in the area skyward across of time.

David, 17, you may recall, is the Creston High School student who flew to Cape Kennedy for the first space shot on July 15, 1968. He, with a 12-year-old brother,

Because of his knowledge of space, David is able to talk daily with army aviator Walter Ciolek.

Working the 10-foot of April 11 was the greatest thing that had not happened in his young life, he said later.

Last June he began drawing plans for the construction of a large liquid fuel rocket for a science fair project and experimental launching.

"I had to buy out all dimensions for the grade dry acid fuel rockets," said David, a junior.

Most of the material came from High when came time to get the "idea," he needed help.

He took his project to Dew Caldwell, who, where Adair's temperature rockets are, watched eye the metal cover was applied.

"I have things in work," he said, "but I never expected to help build a rocket."

After 40 inches across.

The top of the rocket is 22 inches in diameter.

Probably the most fascinating thing about David's rocket is the internal

weight of 1,000 pounds.

rocket and power pump-bell in the mechanism. So better power to all the ground.

When April 11 at Otterbein University they probably won't even get into the tank of fuel in the building," said David. "One that would illustrate my project."

David said he is "not" about

considerable money tied up in the rocket.

He worked last summer in the laboratory of Cape Kennedy, where temperature rockets are, and when the rocket is assembled, of how well it is brought back to work.

Adair said the propellant will be contained in tanks on the outside of the rocket. They start to disintegrate part, ing to 22 feet in diameter.

David Adair may not have all the sophistication of Cape Kennedy, but he has considerable talent, and ingenuity which ought to make his rocket launch successful.

BUILDING ROCKET — David Adair, 17, standing on bench, and Dew Caldwell work on jacket that is nearly 10 feet tall.

(News Photo)

And cryogenic fluids with their temperatures running around 325° Fahrenheit below zero . . . when you detonate something like that, you get a lot of BTUs, so you get thrust.

And now you can start working on all kinds of math tables with that kind of stuff.

But it was all leading to something, and I wasn't even aware of it.

There are only two types of rocket engines today – solid fuel and liquid fuel.

Wilcock: Right.

Adair: We don't use anything else. Well, the big one that I built, Pitholem, she was neither one.

Wilcock: When you say “Pitholem”, what's that?

Adair: Pitholem is the name of my rocket. I was working on it, and I hadn't named it yet. My mother came in. “I just had a strange dream with you.”

I went, “Oh, this out to be good,” because she had some really interesting dreams.

And I said, “So what's the dream?”

So I'm just working away with my back to her, and I'm working on the bench. She said, “I saw these giant bleachers out in the desert, you know, grandstands. And there's railway tracks between them. Big railroad locomotives, several of them, were pushing this giant rocket laying sideways on like a sled. And it stopped, and there was a gantry built way up to meet the door.” You opened the doors, stepped out.

And she goes, “You didn't have any hair on top, but the hair on the sides was white.”

I'm going . . . That's about all I heard for a few minutes. I didn't have any hair? That's not good.

However, she said, “You addressed everybody, thanked them for coming out, and said, 'Let's see this thing. You know, let's not talk. Let's just do this.’”

So I get back in. The locomotives pushes about a mile or two away from the stands. Then they come back, and then the thing just turns on. The sled motors turn on. It takes off across the desert floor. It goes up the side of a mountain, and then she said, “I guess the main engines come on and just . . . you know, you're a welder. How bright it is?” She goes, “It was way brighter than that. It was like the Sun.”

Wilcock: Wow!

Adair: And she said, “We never saw you leaving. We just had an explosion, and it was gone. And the only thing left trailing in the vapors was like a rainbow.”

And I went, “My God, she described electromagnetic fusion engine in our atmosphere perfectly.” And my mom doesn't . . . My mom didn't know that.

So I'm just, “That's interesting.”

And she goes, “Oh, one other thing. There was a name painted on the side of it.”

“Really? What is it?”

She said, “Here, I wrote it down for you. I woke up spelling it. P-I-T-H-O-L-E-M.”

It looks like “pithole”, but with that M on it, it becomes Pitholem.

So anyhow, that's Pitholem. That's where it came from.

Cosmic Disclosure: The Original Rocket Man with David Adair

Season 8, Episode 2

David Wilcock: All right. Welcome back to “[Cosmic Disclosure](#)”. I'm your host, **David Wilcock**, and I'm here with **David Adair**.

So why don't we start from the beginning, because you have a very significant story here. Take us through the story.

David Adair: Yeah, well a chain of events occurred while this was going on. My mother was a nurse, and she – this is 1966 – and she was in charge of a coronary care unit.

And my mother ran third shift from 11 to 7:00 in the morning. And she had this elderly patient, 95 years old, and his name is Irving. And the wife, Arizona, was there. And they had a son named Curtis that would come in about 3:00 a.m. in the morning to see him. Their last name is LeMay.

Wilcock: Ah! Ha, ha.

Adair: So this is Curtis LeMay's parents.



General Curtis Emerson LeMay
Former Chief of Staff of the U.S. Air Force

Wilcock: Right.

Adair: My Mother was the CC technician, and since she is in charge of third shift, Curtis LeMay has to go through my mother to see his parents. So they became friends.

And he would show up at 3:00 in the morning because he's like paparazzi, back in those years, I mean.

You know, former head of the joint chiefs, designer of the B-52, founder of SAC, Strategic Air Command. Guy had a little bit of power.

Wilcock: Yeah.

Adair: So he got to know my mother, and they'd just talk, you know, personable guy. And he asked my mother, "What's your family like?"

She said, "Well, I got my husband and three sons." And then she goes, "These other two sons are only about a year apart. It's pretty much normal," but she goes, "that younger one, he's a little bit different."

And Curtis says, "How so?"

"He's flying all these rockets out in the cattle fields. And they are really fast, and they're big."

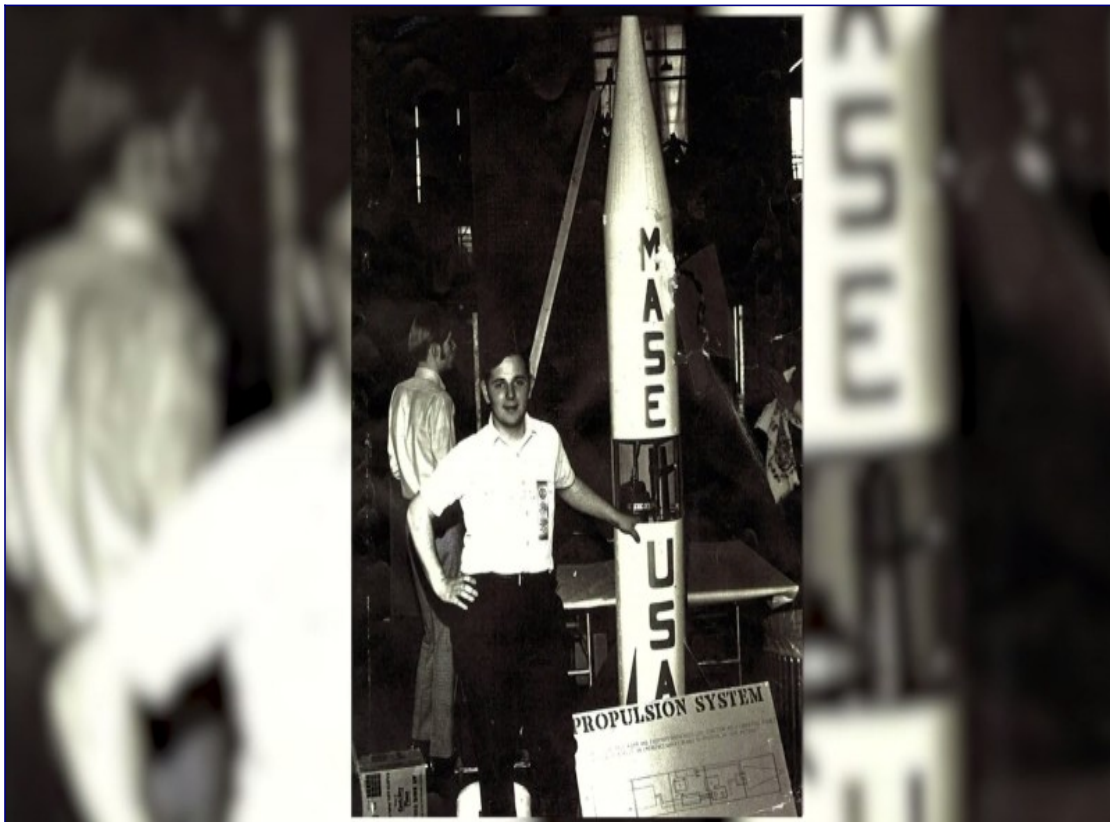

And he said, "Well, how tall?"

And she goes, "Oh, they're about twice my height."



He goes, “Damn, that’s big. And he’s always writing stuff down.”

And that got Curtis’s attention. He goes, “He had stuff written in a book?”

“Yeah, he’s got this big notebook, about 93 pages of it.”

“Could you bring that and let me see it one night?”

So she brought it one night. I go to bed to get up to go to school, so I didn’t even know it was gone.

She comes back 7:00 in the morning, put it back down. I never even knew it was missing.

Wilcock: Oh, wow!

Adair: So Curtis looks at it. He starts flipping through it, and he’s a pretty smart guy himself. And he’s going, “Man!”

He turned around to my mother and said, “You don’t have a copier do you?”

Wilcock: Ha, ha.

Adair: And he copied about a third. Thank God he didn't copy the whole thing. But he copied about a third of it, and he took it to about an hour and a half way from home, to Battelle Memorial. That's a big think tank.

Wilcock: What was in the books that caught his eye? Were you just taking notes from these 1,800 books in the library that you'd read?

Adair: No. To do what I was wanting to do, I'd have to make everything new from scratch. So I extrapolated information as a base point, and then I started my own math. And I went into electromagnetic fusion containment.

Wilcock: For space travel?

Adair: Yeah, for containment of a sun, electromagnetic fields. So Curtis took those pages he copied to Battelle Memorial, and he asked them, "Is that just chicken scratch or something important?"

And their immediate reaction was, "Who is this? Where is this person that's writing this?"

He said, "Some kid launching rockets out in cow fields."

And they go, "My God!"

So LeMay asked, "Is it real?"

They said, "Yeah. We'd like to meet him."

And that's when things started with LeMay.

Wilcock: So LeMay and his people started to think that you might actually have developed a way to contain electromagnetic fusion. Now, was that not being done at the time? And what's the payoff if that works?

Adair: There were some people working on some stuff, Los Alamos. But what LeMay saw was that, according to Battelle, I was on the right track, and I was definitely closing in on it. And they just were kind of flabbergasted that I wasn't at some institution or agency working with whatever.

And to LeMay, his brain was going in something else. So what he smelled was a coup here that he could pull, and that is he would fund me for everything I need, and he would end up with something that he was dearly looking for, which was speed. He was looking for enormous speed, because he had a term that I've never heard before in '71, it's called "first strike".

Wilcock: Right.

Adair: So I just thought, "Well, you're a kid. You're 15 years old, and somebody is willing to give you everything that you need?" Come on, you going to jump on it. You're not going to say "No". I don't think so.

Wilcock: Right.

Adair: And there's been some critics that says, "You couldn't pull this off in a garage by yourself."

You're absolutely right. I needed everybody. And this guy, with his power and his background – although he was a civilian, it does not matter in his power – he had the entire Iron Triad working for him, which is the commercial, and the military-industrial complex.

So we had people working with us. We'd sub parts out that we need, and machine stuff. So I had people like National Livermore Laboratories at Los Alamos, Oak Ridge, Tennessee, Battelle Memorial. The list just goes on and on.

And LeMay was very shrewd. We would break things up into small units, and send them out, farm them out. So when the person's working on a device for us, [he is] not really sure what it is. It might be some kind of propulsion thing, or this might be regulating a flow.

You couldn't put it together unless you had all the parts. And that was very smart of him.

So when everything came back to our building, our assembly lab, I put everything together. And there was a lot of personnel – hundreds of people working.

So it took us 26 and a half months. I'd go to school, get off the bus in the afternoon, and all these people

were at this big garage lab that I had. And I had asked LeMay to get everybody out of their uniforms and wear blue jeans and plaid shirts, so they'd blend in with the locals, 'cause I'm trying to live a normal life here.

And he said, "Oh, man, that's perfect. It's like covert."

And I went, "What's covert?"

He's, 'Never mind. Just keep on going."

And I wouldn't talk . . . try not to talk about much at school, but the kids knew that there was something going on with me.

Wilcock: So what did LeMay tell you the goal was of what you were doing for him?

Adair: What he wanted was . . . he said, "I want the same thing you want, **David.**"

And I said, "Oh, you want an electromagnetic fusion containment fire plant."

And he goes, "Yeah, that's what I want."

"Well, let's see what we can do to get it."

And he knew for me to test my fuel, the best thing to test it in is a rocket body, which is exactly what he wanted.

So Colonel Bailey Arthur **Williams** was the XO for General LeMay. And he was there on site every day. I never saw LeMay. It was just Colonel **Williams**.

Once we got done, we were ready. It was completed after 26 months. And now we're ready to put it in a truck and take it to Wright-Patterson Air Force Base. And so we arrived there.

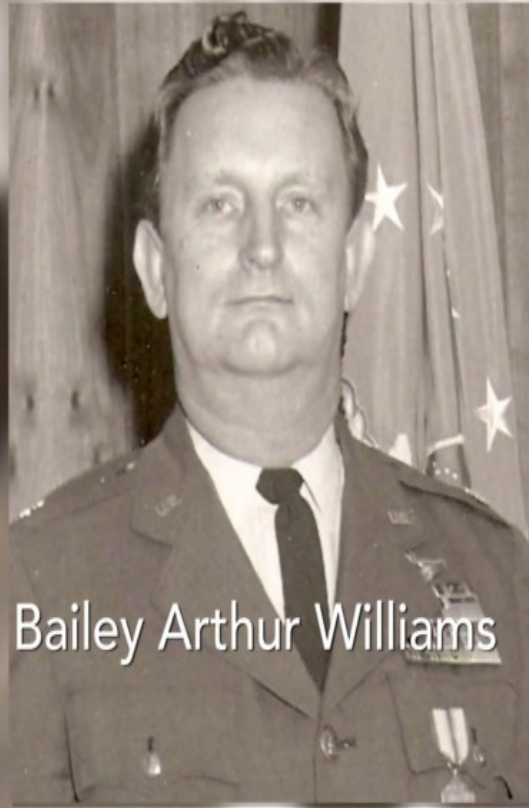

Colonel Bailey Arthur Williams



I do remember this: When we pulled in, there was a C-141 Starlifter. If you've ever seen them things, they are huge.

Wilcock: Enormous.

Adair: And there was this ring of heavily armed Air Force people around the plane. And they told me to drive over to it. I was afraid to pull up to it because I thought something's going on. I don't want to mess up with it.

And then I realized that was for me. That was for my . . .

Wilcock: Ha, ha, ha.

Adair: And I remember just standing there on this apron, big concrete area, and that big C-141 sitting there, and all these military people with weapons, and a lot of security people everywhere.

And I thought, "My God, this is all for me! I'm about to have a heart attack."

So we get the thing rolled up onto the plane, and off to White Sands, New Mexico we go. So we're going to launch this thing.

And when we get there, we prep it. And then that's when more characters started showing up in this story.

It's a long way to explain it, but I had become friends with Wernher von Braun by then.

Wilcock: Ah!

Adair: And people go, "Well, how's that possible?" I won science awards. Oh, man, by the time I was 16, I had won probably over 100 scientific awards.

Wilcock: Wow!

Adair: And some of the trophies were taller than I was. And you have dignitaries hanging medals around your neck. Well, one dignitary was Wernher von Braun, which makes sense.

Wilcock: Really?

Adair: So now we're at White Sands with the rocket.

Wilcock: Did the C-141 actually hold the rocket inside of it?

Adair: Yeah.

Wilcock: Is that why they were guarding it?

Adair: Absolutely. LeMay picked it out. And I said, "Good choice."

So we got to White Sands, and then there was . . . That's when things started.



This black DC-9 landed the next day. And I made a joke with Colonel **Williams** as he's watching the DC-9. I notice he's not smiling. I said, "Where's the white bunny head?" You know, on the side of the tail of the plane, because that's Hugh Hefner's plane flying around those years.

Wilcock: The Playboy bunny.

Adair: Exactly. And I looked up at him, and normally he's really a personable guy, but he's not smiling. He didn't look happy at all. And he had a good reason, because he was worried about something, and he was right.

As soon as the plane rolled up to our hangar, it stopped. Out came these guys, so help me, black suits, white shirts, little skinny black ties. Get closer to them, funny-looking triangle watch. And I didn't know . . .

Wilcock: Triangle watch?

Adair: Yes, it was kind of a triangle-shaped watch.

Wilcock: So they're agents?

Adair: Actually, what I believe y'all call MIBs.

Wilcock: MIBs, yeah.

Adair: That's the first time . . . I didn't know who they were. I just thought, pretty stupid people wearing that kind of clothes in the middle of a New Mexico desert in the summer.

Wilcock: Sure.

Adair: And then one little guy came out behind them after everybody got off. Now, he had khaki shorts and stuff. And I thought, "He's smart! He knows how to dress."

And I'm looking at Colonel **Williams**, and he's not saying a word. And I asked him, "What's wrong, Colonel **Williams**?"

And he goes, "We're in serious trouble."

And he goes, . . . "Well, who's the guy in khaki?"

And then he got closer, and I recognized him from a photo that von Braun showed me. He came in through Operation Paperclip. His name is Rudolph, Arthur Rudolph.



He is the chief architect of the F-1 Saturn V Moon rocket engines of Apollo. But he's also a full Gestapo Nazi, and he had killed . . . he was responsible for tens of thousands of deaths at Mittelwerk, [inaudible] where they had built the V-2 rockets.

And von Braun told me, if he'd ever show up in anything I'm doing, you are in such trouble . . .

Wilcock: Wow!

Adair: . . . because this guy will take command. So at least I knew who he was, and I could tell Colonel **Williams** knew who he was, and the Colonel wasn't happy.

So he come walking over to me. And I went, "Hi, my name's **David**. What's your name?"

He wouldn't answer. Oh he said, "Oh, I'm just a guy who goes around looking at hardware for the military. I understand you got a different kind of rocket here."

I said, "Yeah. You want to see it?"

And he says, "Sure."

So I take him over to it, and he gets on the opposite side of me. The rocket's between us.

And he said, "Can you open it up and let me see?"

I said, "Sure."

So I take a big block of metal in my hand and run it down the hull, and the panel lifts up and slides over.

And he's looking at my hand and that block of metal, and he goes, "What is that?"

And I go, "It's called a dissimilar metal lock." I went, "It's old. It's World War II technology. You don't have one of these?"

He got mad on that one. And I guess I may have insulted him.

But apparently, he didn't know anything about it.

He said, "That's pretty advanced."

And I thought, "It's old stuff. It's not advanced."

So he sticks his head down into the engine area. And I thought, "This would be a good time to say something to him." Ha, ha.

So I lean over, and I was saying to his ear while he was looking down, I said, "This engine has about a million times the power of the F-1 Saturn V Moon rocket engines, Dr. Rudolph." Man, he . . .

Wilcock: Which he made.

Adair: Oh, man. He raised up . . . and I'd never seen anybody get that red before. I mean, he looked like a barber pole.

Wilcock: Ha, ha.

Adair: And he looked at me and goes, "Who ARE you?"

And I go, "I'm just a kid that launches rockets in cow fields over here in Ohio."

And then things just went south from there. He took over completely. He took over the launch. He had me reprogram the off-the-shelf navigation to an area about 456 miles, if I remember right, northwest of us.

Anyway, he dropped it in a place called Groom Lake, Nevada. And I guess y'all call it today, Area 51.

Wilcock: Right.

Adair: I never heard of Area 51 in 1971. Just Groom Lake's all I knew.

Wilcock: So what happened when you got it to Groom Lake?

Adair: Well, once it got out of White Sands and it launched . . . I was curious about Groom Lake, so I pulled geophysical maps, and it says it's just a big dry lake bed.

And I said, "You see this black DC-9's got rubber tires, you gonna warp it's belly in this dry lake."

He tells me, "Shut up and get on the plane."

Well, he's got a good reason, because when we get there, it's big runways. It's an Air Force Base. It's not on my maps.

Well, we kind of circled the base at first, and we saw Pitholem laying out on the desert floor.

Wilcock: And that's your rocket.

Adair: Exactly where they wanted it. That's the only compliment I think I ever got from Rudolph.

He said, "You landed it precisely on mark."

And I thought, "Yeah. Well, good."

Wilcock: The rocket could land?

Adair: On the sides of the rocket, I built these big slip-slide containers that have parachutes. These two parachutes came out, and these parachutes are tank parachutes, 70-ton tank.

Wilcock: Right.

Adair: So the rocket landed just like a feather. There's no damage. It's perfect . . .

Wilcock: Wow!

Adair: . . . just laying on the desert floor, parachutes blowing around it.

So anyway, we land. We taxi over to it. There were three hangars, I remember. And there was a lot of construction going on. This is June 20, 1971, and there's construction all over this base, runways, everywhere.

So we go to the center hangar, and I thought, man, this is really strange. None of this is on my maps, and these are government maps.

Wilcock: Ha, ha, ha.

Adair: I thought, "What the hell is this?"

So anyway, we get off. We get in these funny-looking go-cart things, big ones, really big, carrying like 10, 12 people.

And being in science, and oriented in engineering, I'm looking at these golf cars, and I go, "What the hell is running these things? It's not propane tanks. It's not electric."

It's got a big intake that some kind of light recessed inside gets brighter when it runs. Then when it slows down, the light dims down.

Wilcock: Did it have any exhaust?

Adair: No. And it only made a strange . . . like a whine.

Wilcock: Really?

Adair: Kind of like a spooling effect, like a turbine. I have no idea what . . . And even today, I have no idea what those things were about, but they were fast.

You know, golf carts only go like 10~15 miles an hour. These things did 60~70 miles an hour.

So he says, "Get on this thing," and I did, and we rode into the center hangar. And we stopped, and we're setting there. And then these yellow caution lights start flashing at all the doors.

Then out of the floor comes these little pipes with chains hooked to each part, so a guardrail's coming up. And I thought, "What is that for? They don't want people walking in this building."

Well, we got the answer pretty quick. The floor of this hangar is bigger than a gymnasium. The entire floor goes down. It's an elevator.

And I thought, "Man, that big elevator, and with a concrete floor like that, there's got to be 100 tons of concrete here."

And I thought, "Man, you can't be using chains or cable moving something this heavy." Sure enough, they weren't.

After we got down below the floor, you can see them spin, about 12 of them, spinning in the walls. They're worm gears. That's the heaviest load-bearing gear we ever know of. Each one was bigger than a sequoia tree.

Wilcock: Wow!

Adair: And I thought about that. I thought, “Where'd they cast and manufacture those things at?” Just amazing.

We went down, and I was so . . .

Wilcock: So it could hold a spectacular amount of weight.

Adair: Absolutely. I mean, you could drag an aircraft carrier in there and drop this thing.

Wilcock: Right.

Adair: So whatever they're moving is really heavy.

So we drop down. We go down, and I'm counting feet and estimate we're about 200 feet down, and we flush out with the floor. And man, what you see next is nuts.

You're looking straight forward. The other three walls are solid, so you're looking one way only.

You're look at this . . . it's like Mammoth Cave, if you've ever been in that thing.



Wilcock: Oh, I have been. In Kentucky.

Adair: Yeah, that cavern thing?

Wilcock: Yeah, it's huge.

Adair: It's like that, but this is about 10 times the size of it.

Wilcock: Wow!

Adair: It goes down, I guess, from the floor to the top of the arc is probably 100 feet. That's a lot. And then it comes down to the sides and goes straight down, canters down, and then it's perpendicular walls.

In these walls are all these shops and hangar bays and offices. And you see people working in the office. And we're just getting it on this go-cart thing.

And we go past all these hangar doors every once in a while, and some of the hangar doors are open partially.

And man, I saw some things in there I just can't explain. There was some really unusual craft. I can't tell if they were aircraft or spacecrafts.

[We] went on down further, and there was another thing over in the hangar, and it was open a little bit wider.

Man, this thing was a moose of an aircraft. It looked like a XB-70, the Valkyrie, but it had some different canards and different air intakes. So it's something else.

Now the first Valkyrie was destroyed in a crash. It sucked up a camera plane in its tail.

The second one was in a museum, the Air Force museum at Wright-Patterson.



So what was this thing setting here?

Wilcock: Right.

Adair: And once again, it had all kinds of things hooked up to it and drip pans. Now, this thing's running. I don't know what it's doing.

So we went on down – went on down about a quarter of a mile. And this causeway, the main corridor, it went clear out of sight as far as the human eye could see. And it would curve with the curvature of the Earth.

Wilcock: Really?

Adair: I mean, it's just enormous. So we're riding, and I just asked the guy a very simple question, “Wow, what did y'all do with all the dirt?” And they got so mad about that.

And I thought, why would a question about dirt bother him?

And I just made another off comment. I said, “What did you use, a phaser?” And they got REALLY mad then.

I thought, “[i] stepping on nerves here.” And I thought, “What is going on with this place?”

Wilcock: How fast do you think this golf-cart was going right now?

Adair: Doing about 50 [mph].

Wilcock: Okay.

Adair: So we're covering a lot of area.

Wilcock: Yeah.

Adair: And you still don't see the end of this thing.

Wilcock: Wow!

Adair: But here's where it gets good. Now that I'm kind of calming down from . . . I didn't know there was anything underground.

I was leaning out, just to look around the people sitting in front of me so I could look further, right? And I noticed when I stuck out my arm, there's no shadows anywhere. Like a paint booth. Can't have a shadow because you'll get a run in the paint. You can't see it.

But here's the problem. I can't find any light fixtures. None. No indirect lighting, no direct light, just no lighting fixtures.

Perfectly illuminated, and I have no idea even today how in God's name did you do that?

I have thought that it might be atmosphere. But how do you illuminate an atmosphere? You're breathing your own light?

Wilcock: Did it look any brighter near the ceiling? Or was it just evenly illuminated?

Adair: Evenly illuminated. Perfect. Illumination right down in the corners, which you'll have . . .

Wilcock: Very strange.

Adair: Yeah, that's a word for it.

Wilcock: Now, so you're driving down this hall, and the whole entire time, you're going at 50 miles an hour. You're just seeing offices, offices, offices?

Adair: Yeah.

Wilcock: And hangar doors with craft in them . . .

Adair: Yeah.

Wilcock: . . . and all this kind of stuff?

Adair: Yeah! Yeah! And some doors are . . .

Wilcock: So there must have been hundreds or maybe even thousands of them.

Adair: Maybe, if we didn't keep on driving. Like, we only went like a quarter mile.

Wilcock: Wow!

Adair: But it gets stranger. If things aren't weird enough, no shadows, perfect illumination, gigantic cavern I didn't even know was there, all these hangar bays, and most of them were closed tight. So God knows what was behind them.

Wilcock: Right. And how bizarre it is that you're asking simple questions, and they're getting all angry.

Adair: Yeah, and I mean REALLY angry. I was about to say to them, "Calm down! Gee! God! I'm just asking."

And we come up . . . This is where it gets . . . If it's not strange enough, imagine this.

We pull up on the left hand side. There's this iris, like a camera.

Wilcock: Right.

Adair: About 40 feet in diameter.

Wilcock: Wow!

Adair: That is huge, y'all. We stop, driver gets out, runs over to this glass panel, puts his hand down. And he looks in this scope thing, and then there's a flash, and the iris opens up.

And when the iris opens completely, another, from horizontal, panel comes by to fill in the gap so we can drive across it.

Wilcock: So this was like a retinal scan that he had?

Adair: Yeah, I was sitting there going, "What is . . . Did I . . . Is that a retinal scanner and a palm scanner? We don't have anything like that." This is 1971.

We don't have . . . no PCs, no faxes, no modems, no cell phones, no laptops.

Wilcock: Sure.

Adair: We didn't have a handheld calculator from Texas Instruments. That's a few years off.

Wilcock: Right.

Adair: And you're telling me this guy's got a retina scanner and a palm scanner on a wall that opens this giant iris door? Which I ain't never seen an iris THAT big.

So I'm going, "Man, what's going on with this place? They're packing technology like I've never seen."

And so we go into this big gymnasium-sized room, and it's dark. Here comes the lights.

Wilcock: Let me just ask one question, though. Do you think that iris might be that they would have that instead of a regular door in case something inside exploded, and they needed to contain an explosive force?

Adair: Well, that or security.

Wilcock: Okay.

Adair: They surely didn't want you just walking in there, slide a door open and walk in. You ain't sliding an iris open.

Wilcock: Right, that's true.

Adair: So whatever . . . [The] first impression I got, “Man, there's something really super-duper behind this door they don't want to have anybody just walking in seeing.”

Wilcock: Wow!

Adair: So we drive in, and the lights come up.

I thought, “All right, I'm going to find a light fixture.” I'm looking everywhere – no light fixtures. [It] comes on like a rheostat. [It] comes all the way to full luminosity to match what's out in the causeway.

And I'm going, “God, how do they do that? I'd give anything to know how you do that.”

So we pull up to a stop, and at the far end of the room, this big giant steel platform, like a stage. And then there's something up on the stage, but there's this giant curtain hanging down around it, which is not a material curtain, like cloth. It's like mudflaps off a semi, but as big as this curtain is. It weighed tons.

Wilcock: You're saying “giant”, but could you be a little more specific about the platform and the curtain?

Adair: Yeah. I would say just the curtain itself was over 100 feet wide.

Wilcock: Wow!

Adair: And it stood probably 25 feet tall.

Wilcock: Wow!

Adair: That's big.

Wilcock: So something big is behind there.

Adair: You better believe it. And there's cables that run up to the ceiling, and they just disappear into darkness.

Wilcock: Hm.

Adair: God knows what's up in there. I don't even want to know at this point.

So anyway, they raise the curtain. We get out of the cart. We're all standing there. They raise the curtain, and I was so disappointed.

I thought I was ahead of everybody, electromagnetic fusion containment engine setting up on the desert floor, right?

This curtain rises . . . Think of an 18-wheel semi with big sleeper cab. That's about 70-feet wide.

Wilcock: Yeah.

Adair: Or long.

Wilcock: 70-feet long.

Adair: About 70-feet long, 25-feet wide, 15-feet tall. It's an electromagnetic fusion containment engine THAT BIG!

Wilcock: Wow!

Adair: And I'm setting there, going . . . I had mixed emotions. I was disappointed, but I was just thrilled. Like, good God, mine is only about 2½ -feet long, and this thing is just a monster.

Wilcock: Let me ask you a question then. Do you think that when LeMay saw the original 93-page notebook that your mother showed him, that he was seeing blueprints that you were making that looked similar to this very valuable object that they had in Area 51?

Adair: I think Battelle did.

Wilcock: Okay.

Adair: You know, Battelle Memorial, in 1971, they had 137 Nobel laureates on staff.

Wilcock: Wow!

Adair: It's a powerhouse. Well, a group of them figured it out, looking at the math. And they can tell by the math which direction or shape you're taking in physical form.

And so I would imagine that somebody in that group knew about this thing, or made LeMay know of it. But to be humble, I was very humbled at the moment, because I had a Model A, and they had a Lamborghini.

Wilcock: Wow!

Adair: And even though the Model A and the Lamborghini are so different in powers, both of them are internal combustion engines, okay? They got some similarities.

Wilcock: Was there a color? What color would you say it was?

Adair: It had an aqua color, like ocean blue-green – really pretty. And it had a sheen to it. But unlike mine, this big one had an ectoskeleton structure over it, which I thought, “That is so weird”.

And it looked very much similar. It looked like HR Giger's work.



Wilcock: Really?

Adair: Yeah. And I thought, “Man, what is this?” Well, I had to ask. [i] looked at Rudolph, “Is this thing a machine or is it organic?” I can't . . . Because the ectoskeleton structure looked like bone.

Wilcock: Really?

Adair: And I'm setting there going, “Man, all I can say, that's alien-looking!”

Wilcock: Okay. If you say it looked like bone, and it was an ectoskeleton, would it be something that had a regular matrix structure, like chicken wire? Or did it have certain areas that were thicker, certain areas that were thinner? Were there dendrites?

Adair: Well, you know how bones start off thicker at the spinal column, like a breath cage.

Wilcock: Oh.

Adair: And it's breath caging all around. It's really protected well.

And there was steps leading up to the platform where it's setting.

Wilcock: In the bone?

Adair: No, we're back at the platform.

Wilcock: Oh, okay.

Adair: I turn around and ask Rudolph, “Can I go up the stairs and onto the platform and get close to this thing?” Air Force people say, “No!” Rudolph says, “Yes.”

And he's obviously in charge, because they just got quiet.

So I went up the steps, walked up to this thing, and that's when the weird stuff really started. You think weird now, it's going to get more weird.

First thing I noticed, my shadow's on it. And what I've been seeing through the whole thing, there's no shadows anywhere.

Wilcock: No shadows.

Adair: So I'm spinning around, looking everywhere, and I see no light fixtures.

Okay, we got luminosity with no light fixtures and no shadows. Now we got a thing sitting here that's got my shadow on it. Of course, normal down here.

And I noticed something else. As big as it is, on my device, I had probably five miles of wiring, screws nuts, bolts, well-aligned seams and all this stuff.

This dang thing, as big as it was, not one screw, rivet, weld line, seam. It looked like it grew, like an eggplant.

And I went . . . I was just dying to turn around and say to him, "How the hell'd you build this thing?"

And I figured I already got enough trouble asking about dirt. They'd really go nuts on that one.

Wilcock: If you say it's aqua blue, did it have . . . In terms of its specularity, was it glossy? Was it flat? Did it have a kind of an aluminum look? Was there particles in it?

Adair: Different areas – the bone ectoskeleton structure, that was flat. The big round spheres, which in my engine would be cyclotrons, they were like the aqua color, but they were smooth.

And when I walked up to it, I noticed my shadow, right? And so I go like this [raising his arms up], my shadow is just a split second behind me.

Wilcock: That's weird.

Adair: I was just . . . I'm watching it, and I turned around and looked at Rudolph, and he was happy. I could tell. Like, "Uh-huh, you're getting on and picking this up, are you?"

And I look at him, and he and I are the only one really eye connecting. Military people are like a different world.

So I just went, "Is this heat recognition alloy?" It's picking up the heat radiation off of me, and then

reflecting it on the hull.

And I thought, “God, that's pretty cool.”

Wilcock: Well, I hate to stop you right there, but we have to make episodes.

Adair: Yeah.

Wilcock: So that's all the time we have for in this episode. It's very fascinating. Sorry for the cliffhanger. But we're going to be back with more with **David Adair**, our special guest here on “[Cosmic Disclosure](#)”. I'm [David Wilcock](#), and I want to thank you for watching.

Cosmic Disclosure: The Descent Into Area 51 with David Adair

Season 8, Episode 3

David Wilcock: All right. Welcome back to “[Cosmic Disclosure](#)”. I'm your host, [David Wilcock](#), and in this episode, we'll bring you another round with our special guest, **David Adair**, a man who actually was able to walk around in Area 51.

David, thanks for being back.

David Adair: So glad to be here.

Wilcock: You're describing this thing that looks like you've just rolled into the scene of a horror movie.



Adair: Ha. Could be.

Wilcock: You've got some alien creature, if you will, with bones around it, and it's gigantic. You didn't have any fear as this is all happening to you.

Adair: Yeah, you're the first person that ever asked me that question. No, I was having fun.

This . . . The only thing I was scared of is Rudolph, you know? That human down there is dangerous, you know?

No, this thing was just . . . I was just mesmerized, you know, because every time I see something, I've got about 50 questions behind that.

And when the thing started interacting, you know, shadows and stuff like that, I thought, "Man, what is going on with this thing?"

So I turned around and asked Rudolph, "Can I climb up on top?" Because the bone work like lattice work. It's like a rib cage casting down on each end and then meeting in the center. The ribbing would kind of interlace, so it's protecting the big structure underneath.

Wilcock: So you could climb it like a ladder?

Adair: Well, you could. It's just . . . Think of a big skeleton of a dinosaur. You can crawl up that thing. So because it had angles and horizontals, and perpendiculars, so you're got ways of climbing up on it.

So I looked at Rudolph, [and I] said, "Can I climb up on this thing?" And he said, . . . First thing you hear all the Air Force people, "No!"

"Yeah, go ahead."

Wilcock: Ha, ha.

Adair: And I actually said thanks to him – about the only time I ever really thanked him.

So I crawl up on this thing, and as I'm crawling on the bone, wherever I'm touching the bone structure,

nothing. But the big smooth area that's recessed inside that the bone structure's protecting, when you touched it . . . I swim with . . . go to a place where you swim with dolphins and all that.

Wilcock: Uh huh.

Adair: If felt just like a dolphin's skin.

Wilcock: Hm.

Adair: And you push hard, and I pushed on it, it would go in a little bit, and then it's just like rock. So it's like organic covering with steel or some kind of alloy on the inside.

Wilcock: So were you about 25-feet up when you got to the top, off the ground?

Adair: It's 15-feet high and 22-feet wide.

Wilcock: Okay.

Adair: I was about 15-feet up – about 5 feet more than a basketball goal, which is pretty tall.

Wilcock: Yeah.

Adair: Don't want to fall off. You definitely would feel it.

Wilcock: Right. You wouldn't . . . It wouldn't kill you, but you would be hurt.

Adair: You definitely would be hurt. So I crawl up on top. But when I pull myself up, I pushed against that smooth area, and then the thing . . . it started reacting.

Wherever my skin would make surface contact around my hand, cascading down inside would be these really pretty blue and white waves – kind of like that wave motion machine you sit in front of executives to keep them calm, a little device you can buy.

Wilcock: Blue and white, as in, like, light? Or what did it look like?

Adair: It had its own illuminosity. You could see it outside of the other material. And it actually glowed a little bit and would run down its side. You'd pull your hand off of it, and it would dissipate at the most outer reach, and then come back to where the original contact was, and that'd be the final area that would dissipate.

Wilcock: Did you feel any electrical charge or anything as that happened? Any heat?

Adair: No heat, but there was something going on, because I noticed the hair on my arm was standing up.

Wilcock: Ah.

Adair: So there was . . . but it wasn't any electrical charge. Maybe static, but I didn't get a shock.

Wilcock: Okay.

Adair: You could definitely feel something going on.

And so I lift off of it, and I turned around and looked at Rudolph, and I put my hand on it, and they're watching it, right?

And the way their faces look, it's . . . I looked at them. I said, . . . I took my hand off and I'm looking at their faces, and I take my hand back on it, and they were looking at it, and I was like, "Y'all haven't seen this before, have you? Huh."

And they got made over that. And so apparently, they can't get a reaction.

Wilcock: It likes you.

Adair: I guess. If it was a cat, it's be purring, I guess. But I asked Rudolph, "Can I climb up on top?" And he says, "Go."

Air Force, "No."

"Yeah, go ahead."

So I get up on top. And you're walking down what looks like – this is really weird. It looks like a giant spinal column with vertebrates.

Wilcock: Wow!

Adair: And there's a bone plate that . . . I would say it was probably about 4-feet wide, and then the vertebrates at . . . and then . . . It makes it very easy to walk. So I just step over the vertebrates.

And then I notice in between the vertebrates, there's this big bundle of . . . It looks like fiber optics. But it's not really fiber optics, because it's got a fluid running through it.

Now, the best way I can describe this fluid is, when we were kids, you'd fall and hurt your knees, get skinned. Your mom would come at you with this bottle, and you're going to hate this, cause it's called Merthiolate.

Wilcock: Ha, ha, ha.

Adair: And it's going to burn like holy fire when it hits your skin. But the color of Merthiolate was so unique. It's bluish orange green iridescent. You hold it up to sunlight, the bottle, it was gorgeous-looking.

Well, anyway, that's the kind of fluid running through these tubes.

Wilcock: Weird.

Adair: And they run all the way down the whole length of the spinal column.

But then I lean over and look down, and it's really cool. These fibers break out of the trunk case every other . . . almost every vertebrate, and they spread out running down its sides.

And when you back up from it, like down on the floor, you can see it clearly then. It looked like a human's neural synaptic firing system.

Wilcock: But you said they looked like fiber optics. So this . . . that part doesn't sound biological.

Adair: No. It just reminds me a little of a lyric or in a song, "partly fact, partly fiction, a walking contradiction." That's what this thing was.

Wilcock: Ha, ah.

Adair: It's like . . .

Wilcock: Was it breathing?

Adair: That was something I checked for. Remember I put my hands on it?

Wilcock: Yeah.

Adair: I stood there, and I was being real quiet, and I was looking for a pulse or breathing.

Wilcock: Right.

Adair: I didn't feel anything. But by God, it wouldn't surprise me if it did.

Wilcock: Yeah.

Adair: If it sneezed, I would have jumped.

Wilcock: Ha, ha.

Adair: So anyway, I'm walking down it. I'm heading toward . . . and I think of a figure eight, an hourglass, a figure eight where they cross over. Right at the crossover, on . . . God, I don't know what's front and back on this thing, but the side facing out to us, there was a hole that was deep.

Wilcock: A hole?

Adair: A hole.

Wilcock: Like it had been shot and damaged?

Adair: Yeah. And to make things more confusing in trying to figure it out, something machine-like, where you'd blow a hole in it, the metal would be really sharp – shards and hanging around the blast area. It would be really sharp.

I saw a picture once, and it looked just like this. When they fire a harpoon into a whale, it has a grenade charge, and it detonates. God, what that must feel like to that whale. But they blow a big hole in the whale, and you see a big hole. And you see the blubber, right?

Wilcock: Right.

Adair: That's what this blast radius looked like.

Wilcock: Really?

Adair: It looked like blubber, not shards of metal. And actually, that . . . Now, that's starting to disturb me, . . .

Wilcock: Sure.

Adair: . . . because that looks like meat. And I thought, “Man, what in . . .” You know, I kept asking them, I said, “It's like . . .”

“No, it's a machine.”

“No, it's organic.”

“No, it's a machine.”

It's like you go back and forth as you see things.

So I lean over the side and look down the hole and asked Rudolph, “Can I take a look inside the hole?”

Wilcock: Are there any lights or controls or visible . . .?

Adair: No, it's dark in there.

Wilcock: Okay.

Adair: Which, I don't know why I even wanted to go down in there. It's kind of nuts to think about it. Why do you want to crawl in a dark hole?

Wilcock: No kidding. Especially, this is already, like, a scene from a horror movie, right?

Adair: Well, I figured at this point it doesn't matter. I'm gone anyhow, so . . .

Wilcock: Ha, ha, ha.

Adair: So I asked Rudolph, “Can I go inside this hole?”

Boy, the Air Force people went from “no” to “definitely not”. Rudolph said, “Quiet. Yeah, go ahead.”

And so I stepped down, and I'm expecting it to be mushy, you know, give way, but it doesn't.

Wilcock: Did it smell like anything?

Adair: There's another good question. There was an overall scent to the thing. I know this is going to really sound strange. It smelled like baked goods.

Wilcock: Really?

Adair: Now you'd expect some kind of chemical, metallic odors and stuff, right? No, this thing smells like cookies. I have no idea what that is.

Wilcock: Weird.

Adair: So I step on the . . . on the torn flesh, blubber, metal, whatever. And when you step on it, it doesn't give at all. You can feel that it's like, almost like a rubber, a real hardcore rubber, like rubber on a tricycle tire, you know?

Wilcock: Uh huh.

Adair: And I thought, "Man, what is this? What is this thing made of?"

So I step down. I squat down and just slip . . . And just as soon as I get to the event horizon of the area, a light comes on inside. It's like a blue light.

Wilcock: Really?

Adair: Very light baby blue. And you can see things down in there. And I'm looking at this going, "Oh, man! What . . ."

Whatever interacts with this thing, it's got to be a bipedaled anthropoid, because there's a . . . The floor has a platform that drops off.

There's a chair - like chairs we're sitting in, and you see our feet are here. That means we have legs and knees bent. So whoever is fooling with the thing is built like me and you.

Wilcock: Same sized body? Bigger, smaller?

Adair: Same. About the same size.

Wilcock: Okay.

Adair: A little bit bigger so it can accommodate you with some comfort.

So I slide on down in there. And this is where it's really interesting. Apparently, this is a power plant that would be inside a spacecraft. It's gotta be.

Blast came through the hull of the craft, came into the side of the engine, blew its way into this area. And what I think this area is, is a diagnostic center. It's where maintenance people, or crew members, would sit down in this chair.

There's no chair there because you can see some outlines, remnants of a chair. But the blast came through, come through the wall, through the chair, taking it out, into this wall.

Wilcock: About how big is this room that you're in right now?

Adair: About the area between me and you.

Wilcock: Oh! So it's pretty small.

Adair: Like a cockpit.

Wilcock: Okay.

Adair: So . . . but this wall over here on the right, you're sitting down, there's, like, an observation window, which I thought was the coolest thing, because if it's running, that means you can see the plasma flow in this thing.

Wilcock: Wow!

Adair: That'd be so cool. How cool would that be?

But the blast went through the wall, and the next thing you encounter would be the electromagnetic shielding, the fields.

Whatever blasted through there, it either . . . the wall, the fields, stopped it, or they both stopped at contact. Because as soon as this made contact, simply because that kind of blast occurred, and the rest of it's intact, you would have to shut down in a picosecond, about a trillionth of a second.

Otherwise, the engine would have been vaporized by the heat that's inside the plasma fields. Inside the electromagnetic fields, nothing would survive.

So it shuts down real . . . a fail safe. That's how you shut it down in an emergency.

So if somebody was shooting at this thing, they knew exactly where to hit.

Wilcock: Wow!

Adair: I mean, within an inch. They knew exactly where to hit the thing to shut it down and still keep it intact.

Wilcock: Did you look for a control surface with the seat?

Adair: Yes, I did. Matter of fact, I sat down in what was left of the chair, and right in front of me are these two big pods about the size of a volleyball if you cut it in half.

And they've got indentations, and it's where your digits go. However, it wouldn't be like that. [**David Adair** puts his hand out palm down.]

The only way you could get your hands into it, us, you've got to put these two fingers together. [He brings his middle finger and ring finger together. Then he raises both hands and shows his index finger, middle and ring fingers combined, and his little finger.]

So that's what you've got. And then you set it down, and you'll sink down till the top of your hands are even with the surface of the pods.

Wilcock: Are you saying that there was more width in the area where your two fingers go together?

Adair: Yeah, just enough for you to sink down into it to where the top of your fingers are now flush with the pod.

Wilcock: Okay. Okay.

Adair: So it was obviously . . . That's what you're supposed to do.

Wilcock: Well, now this is interesting, **David**, because this sounds very, very similar to what Arnold Schwarzenegger puts his hand into at the end of “Total Recall”. And I'm wondering if they might have borrowed that from you, because you might have done this testimony before they made that movie.

Adair: Oh, yeah. I remember seeing that.

Wilcock: Except his . . . It's these two fingers in “Total Recall” [[David Wilcock](#) holds his index finger and middle finger together] not these [middle finger and ring finger]. But it's very similar-sounding.

Adair: Yeah. Well, this is how I did it.

Wilcock: Okay.

Adair: Yeah, but if I remember “Recall” right, the next thing didn't happen. I sat down. I finally get my hands settled in, and no sooner than I get them all settled, I thought, “Well, this is cool. It fits.”

These interlocking rings came up like a . . . I saw a Batman movie with the Batmobile and its shield. And it goes, “Chink, chink, chink, chink, chink.” You know, it's covered.

Well, that's what it did, except it was faster than the Batmobile. It just went, you know, “Ching, ching, ching, ching”. And it was already up to your knuckles.

Wilcock: Wow!

Adair: And this thing has got you. Then all those rings started tightening down, and I was thinking, “It's going to cut my fingers off if it don't . . . “ So I started to yell for help.

And it's just . . . The interaction with the thing was . . . That's what it was designed for. Maintenance people would put their hands in. I didn't build it. I don't know the language. I don't know anything.

So it's just . . . You know, I just wonder what they did with it. But obviously, it was designed to maintenance. And with that window to look at the plasma field, obviously, they would do alignments.

That's something else I saw in the plasma fields. I have these very specialized plates that move the electromagnetic field so I can . . . for efficiency.

Wilcock: Uh huh.

Adair: They had something that looked like a tetrahedral turned inside out. And they were spaced all along the walls, but they were all in line of sight with each other.

So I think that's how they . . . I don't know what they're doing. It was just . . .

Wilcock: So you saw tetrahedrons inside?

Adair: Yeah.

Wilcock: What do you mean “turned inside out”?

Adair: It's the way . . . You know how they look like a Moravian star?

Wilcock: Uh huh.

Adair: Okay. Imagine you take a Moravian star and you do a reverse of it. One spike would go this way. It'd actually go in the other direction.

Wilcock: Okay.

Adair: And I could tell it's like some kind of reverse matrix that's not known to us. Maybe it had something to do with polarity of the electromagnetic fields. I don't know what they were doing. I didn't design it.

Wilcock: Right.

Adair: And I guarantee you, they were smarter than me.

Some of the designs, though, I saw throughout the thing, I memorized. So when I reassembled my own version again, I cheated. I was told their idea. They had better ideas.

Wilcock: So you must be scared. This thing is – pfft! It's like popped over your hands.

Adair: Yeah. Well, I just . . . Yeah, I just about freaked out, and I started to yell for help. And it says . . . There's a voice I can hear. And it says – sounds like Lauren Bacall . . . Ha, ha.

Wilcock: Really?

Adair: Some female sultry voice, and it says, . . . like Veronica Rabbit, or something like that. It just . . . “Be quiet.” And it's got a hold of it.

And I went, “Okay.” You know, like, “Oh, God!” You know, how stupid am I? I crawled inside an alien vehicle, stick my hands down in it. It grabs hold of me. God knows what's going to happen next.

You know, I thought, “I'm not thinking through this stuff. It's too much . . .” A phrase kept going through my head, “Curiosity's going to kill the cat,” you know. There was definitely information exchanged.

I remember coming . . . It was really like an intense heat coming up my arms. And when it got to where my neck was – carotid artery – it's just like . . . All of a sudden you have a heads-up viewer.

Wilcock: Oh, wow!

Adair: And images you see are just unbelievable. I couldn't make sense of anything. I saw different star systems.

What I came away with is impressions. That's how I think it talks to us, anyhow, because I guess we can't speak their language, so how else do you communicate?

Well, we are beings of feelings. That's a whole new world, another way of communicating, like body language. Well, this is feelings and impressions.

Wilcock: Did you see any hieroglyphics or unusual writing like that?

Adair: No, but I saw entire civilizations, advanced worlds. This thing is a power plant that is intercon . . . it'll connect into a big craft. Then you have a crew. All three are sentient beings.

Imagine your power plant's alive. Your spacecraft is alive and your crew, and y'all interlock with each other in symbiotic relationship.

Wilcock: Wow!

Adair: What a way to travel through space, God almighty! Pretty much eliminate the need for damage control. Think about it.

You get in some trouble, get hit or something, you're the captain sitting in the bridge. You don't need somebody to tell you where the . . . You know where we've been hit because you feel it.

Wilcock: Right.

Adair: You're aware of it. You know, somebody blew a hole in your side. You would know it.

And even if you didn't have visuals, you could tell where the enemy is anywhere around you.

Wilcock: Right.

Adair: Man, wouldn't the Navy like to get a hold of that?

So anyway, I thought – you know, what felt like maybe hours. I'm sure I was there just a few minutes, because the people downstairs didn't even seem to be, you know, alerted it was long or even that I'd been in there too long.

So I come out. And soon as I got to the opening, the light goes back down – just, like, shuts off. Some kind of, you know, sensory.

Wilcock: I'm curious, though. Were you able to see in these visions what these people originally looked like or anything about their civilization? What the buildings were?

Adair: Yeah, there were a few things that stuck in my head. Apparently, this symbiotic society, it's old, man. It's not thousands of years. It's not a million years. This thing's like eight or nine billion years old.

Wilcock: Really?

Adair: It's the oldest thing there is in the universe. You know, it's just . . . It's the first of the species of the universe – not just the galaxy, the entire universe.

Wilcock: Wow!

Adair: And home to them is the space between the galaxies.

Wilcock: Really?

Adair: Kind of like a whale living deep in the ocean. That's where these things reside, I guess. And they're a mixture of . . . kind of like – now that we know it – kind of like the Borg.

Wilcock: Uh huh.

Adair: They're a mixture of birth and construct all together, all at once.

Wilcock: Did you get a sense that they were a positive people, not like a warlock, evil race?

Adair: No. But apparently, I can't . . . just images, impressions. But this thing must have been in a knock-down, drag-out battle of some kind.

Wilcock: Hm.

Adair: And it got wounded, and that's the best word for it. It got wounded in a conflict, and so it's looking for a place to land, you know, repair itself or heal, heal up. I don't know what it does.

Where are we as a planet in our galaxy? Where are we? We're right out on the very edge.

Wilcock: Yeah.

Adair: It flew into our galaxy. First planet it came on, M-class planet, probably been us.

Wilcock: Hm.

Adair: So it slides in. And they may have found this thing. We wouldn't have been capable of shooting something like that down probably. Nah.

Wilcock: Right.

Adair: No, they dug it up. Maybe that's why they built Area 51 where it's at . . .

Wilcock: Hm.

Adair: . . . because they hit a treasure trove, which means the spacecraft is somewhere, and it's big. So if you're going to follow that matrix, that means the crew's somewhere around.

Wilcock: Do you think that a reactor like this could power . . . would have enough energy density to power an entire city like Los Angeles?

Adair: Oh! Not just city. It could power an entire planet.

Wilcock: Really?

Adair: You know, carriers come in. Like, one of our naval carriers went to Beirut, and they ran their reactors into Beirut and ran the whole power supply of Beirut till they got the infrastructure up. The place has been just bombed to death.

This thing could land on a planet. This power plant can be extracted easily. It's only got four disconnects and lifts right out.

So you could drop it off and power an entire planet with it.

Wilcock: Wow!

Adair: So it's just . . . I don't know how much power the thing's got.

Imagine not just a yellow star like ours to a medium star. And you pour a million Earths inside the thing, it's so big.

I think this thing's got the power of a giant blue. It's just unlimited.

Wilcock: Wow!

Adair: And I couldn't imagine what weaponry of something like that, but the thing never seemed to have a need for weaponry. Maybe defense.

But anyway, I crawled out of this thing, and I had a different attitude. That was an excellent question you asked me – was I scared?

I never was scared of this device or anything in Area 51. I was more scared of Arthur Rudolph than anything.

So I got out, but I am so angry when I come crawling out of that thing, I guess, because I've seen so much.

And what hit me is that, "Nobody knows about this. Nobody has a right to keep this kind of knowledge away from everybody."

I stop, and I talk to these guys again, the Air Force people and Rudolph, and finally, I just . . . They asked me something, and . . . Oh, they wanted to say, "Did I learn anything in there that I could tell them how this functions?"

And that was the last straw.

I just yelled down to them, "Look, this thing is not ours. It's not theirs, the Soviets. As a matter of fact, it's not from the neighborhood, is it, guys?"

I said, "And how old is it? How long have you had it? And did you shoot it down? I don't think so. Did you dig it up?"

Boy, now they're bristling, and they are furious. And I don't care anymore at this point, because I told them, "Nobody, I mean nobody, no president, no head of state, has a right to withhold this kind of knowledge from the entire human race."

Wilcock: You said this out loud as you're standing up there on the platform?

Adair: Oh, yeah! Yeah, it's a good place to . . .

Wilcock: In the middle of Area 51?

Adair: Yeah, it's a good place to . . . Ha, ha, ha.

Wilcock: Ha, ha, ha.

Adair: I hadn't thought of it till you said that. I guess I was stump preaching. Man, look at the stump you're standing on.

Wilcock: Ha, ha, ha.

Adair: But I don't know, I just had this . . . I'm normally very easygoing and everything, but boy, at that moment, I am just furious.

And I'm saying things. I thought, “**David**, did you just say that to them?” Yeah, and I'm pissed off.

Well, they're angry. And they tell me, “Get off the damn thing.”

So I'm coming down, and when I put my hand back on the smooth area on the innards of this thing, as soon as my skin hit it, cascading 20 or 30 feet down the side of this thing, way longer than the blue and white, now it's red, orange flames going down, halfway down this thing's body, wherever my contact is.

I pulled it back [his hand], slapped it on again, and it's there.

And as I'm marveling at what's happening, it starts retracting back down. Then it turns back to blue and white because I'm calming down.

This thing is not heat sensitive recognition alloy. This thing is feelings recognition. This thing feels me. It knows when I'm easygoing and when I'm really pissed off.

How in the hell does it do that? It's interacting.

Well, anyway, we come down off of the engine. All they tell me is, “Get on the cart. Get in the back.” You know, just real curt.

So I get in the back, and I'm facing outward, and they're driving forward. And we're going back up the causeway, back up to the elevator so we can go back up to the roof, the other floor.

And that's when I hear these guys whispering, because the wind's blowing past them past my ear. I can hear them, and they don't think I can hear them, and I hear everything.

And they're saying, you know, "We've got to get him to help us figure out how this engine works or get him to replicate another engine" like mine so they can have one to take apart and one to have working. And that way, they have a completed cycle, and they can start mass producing.

And they said they need it for "the first strike fleet."

And I'm going, "God! How many do they plan to build?" Well, how many nuclear warheads did we have in 1971? 4,000? So they want my speed.

Wilcock: Right.

Adair: How do you . . . How do you win MAD? MAD, Mutual Assured Destruction. It's what we live under, have lived under since the Trinity test. [Trinity was the code name of the first nuclear bomb test under the Manhattan Project, July 16, 1945, in New Mexico.]

The only answer to winning MAD is speed. Whoever strikes first and strikes the fastest wins.

Wilcock: Right.

Adair: And I just gave them the vehicle they need.

Wilcock: Oh, wow!

Adair: And I thought, "I'm trying to build you a power plant. You want to go nuke half the planet." Because they're not thinking. If you nuke the Soviets, who are you going to have to kill that same day? China. Now you're looking at 50% of the population of the planet.

So what you're talking is a worldwide military coup, and we will be reigning kings. That's horrifying. That's worse than the Germans.

And now I'm getting even more pissed, because I'm trying to give you unlimited energy, clean, change the carbon footprint. I'm not a tree hugger. I'm a science person, you know? I build things.

But this is good for you, your kids, your grandkids. You'll bring carbon footprint to a halt.

Another thing this engine can do, I can go send one over to Yucca Mountain, burn all of its waste into my reactor, give you energy and get rid of the waste forever.

I mean, man, this thing could really change this place. And here they want to make a weapon system out of it so we can . . . So that's all they think when you first discover nuclear power. What do you do with it? Build a nuclear power plant? No, you blow a hole in the ground.

Wilcock: Ha, ha, ha.

Adair: So it just really pissed me off. And I'm riding up to the surface on the elevator, and I'm thinking, "I've got to blow my rocket up. This just sucks."

It took me 26 months to build this thing. It came out of me. It's like . . . It's like you have a child. And now, because of their moronic ways, you're going to have to kill your child. That sucks!

So I get up to the hangar . . .

Wilcock: Now Curtis LeMay was one of the Joint Chiefs of Staff, I believe, during John F. Kennedy's administration.

Adair: That's right.

Wilcock: Yeah. So you're talking about the highest levels of the American command structure that want to use this for first strike.

Adair: That's correct. I can see where you're going with this. Ha.

I don't know what to tell you, man. I'm just an average guy, and I just realize everything's getting perverted. They just want to do destruction.

How much have we learned from all the wars? Not a damn thing, except how to kill more efficiently.

So here's the problem with, how do you blow up a rocket on a top-secret Air Force base, and you've got nothing but your clothes? What are you going to do?

So I'm sitting there, trying to think. I thought, "Oh, God! Come up with something. I can't let them walk away with this."

So I saw the answer. We pull up, the elevator levels out up at the top. We're back in a hangar.

So I walk over to the hangar doors, and I look down at the wheel and there's a hub. So I just kind of lean down like I'm sitting against the door and reach down and get a handful of graphite grease.

Ask anybody what happens when graphite meets deuterium. It's a violent reaction.

So I start screaming and hollering, "I'm never going to see my rocket again. You're going to take it away from me." Just being a whiny little thing, because Rudolph can't handle that.

I said, "At least let me see it once before . . ." and he told the two guards, "Take him on the cart and go out there." I need to check the engine out there anyhow.

So we went out there – just me and these two guards.

So we drive up. I said, "You know what, you guys mind staying in the cart here? This thing may be leaking." Them guards aren't going to move.

So I get out.

Wilcock: Ha, ha, ha.

Adair: I go in. I open up the induction chamber, slide in the graphite. It's going to be pulled into the cyclotrons, and the cycle will start up in 90 seconds. Hope that's enough time.

Wilcock: Oh, wow!

Adair: So I set it for 90 seconds, close the door, and you hear it winding.

I turn around to these guards and go, "Oh, my God! It's leaking! Do you hear that whine?"

“Yeah!”

“It's going to detonate.”

We get in that car, and man, they are leaning forward, you know, ha, ha, to see how fast they can get . . . We were just touching the high spots on the ground. (Eeee . . .)

Wilcock: Oh, my gosh!

Adair: And he asked me a really good question like you asked. “What's a safe distance?”

Wilcock: Ha, ha.

Adair: And I'm sitting there going, because . . . Oh, God! If it goes nuclear . . . I went, “Chicago!”

Wilcock: Ha, ha, ha.

Adair: And the guards look at each other, and they lean forward, you know! Ha, ha, ha.

Wilcock: Ha, ha, ha.

Adair: We go hell flying through there and more likely to be killed in this damn cart than the blast.

But we get up to the hangars, and boy, Pitholem, she detonates. And it blows a hole the size of a football field, about 100-feet deep. Did not go nuclear.

Wilcock: Oh, wow!

Adair: Just convention. But biggest piece they found out there, about the size of my thumb.

Wilcock: How loud was it? Did you have some hearing damage?

Adair: As a matter of . . . Man! Those are fabulous questions you ask. Yes, I have permanent hearing damage in the ultrasonic rings in both ears forever.

Wilcock: Wow!

Adair: Kind of handy, though. I could be laying in a room and there's a cricket. I can't hear it. Anybody else is going, "God! I can't stand that cricket!"

Wilcock: Ha, ha, ha.

Adair: "What cricket?" You know? But if we hear in mid-range and low-range, I'm fine. But the ultrasonics, gone.

Wilcock: Wow!

Adair: No one ever asked me that. So it's real. This is real stuff. It's real permanent damage, real reactions.

Wilcock: Yeah.

Adair: So even the audiologist, when he takes my reading, he went, "Man, what hit you?"

I said, "Why?"

He said, "The way your inner ears and the stirrups . . . it must have been an ultra-high-pitched . . . It must have been one whale of an explosion."

I went, "Yeah, it was."

So anyhow, I get back up there, and now I'm going to show you how smart Rudolph is. He's just looking at this, you know, mini-nuclear cloud out there. And he looked at the guards, and he said, "What happened?"

"He says it was leaking."

Now he knows these things don't leak. So he's looking at me, and he grabs my hand and rolls the hand over, and he looks at the hangar door. That's fast.

Wilcock: Wow!

Adair: And he just looked at me, and he goes, “Very clever!”

And then he just hits me so hard my lower teeth pushed through my lip. And I hit the ground, and I'm spitting blood everywhere.

Wilcock: Oh, wow!

Adair: I've got a really nice looking scar inside. And I hear all these guns cocking, and I thought, “Man! Just at this point, just go ahead and shoot me! I don't care.”

And I roll over and look up, and guess where all the gun barrels are pointing? At Rudolph.

Wilcock: Really?

Adair: These are Air Force personnel. He's a Nazi. He just smacked the heck out of a Midwest Ohio boy in front of these Air Force people.

And I look up, and I went . . . you know, just bleeding everywhere. And I look up, and I went, “Well, Rudolph, I guess you're not in charge after all. And apparently, these guys looked like they ain't through with World War II yet.”

Wilcock: Ha, ha, ha.

Adair: And he had men in black there, and they grabbed me. And off we go. And we go through the hangar, go through an office area, and then down a hallway.

And I'm put in this room where there's no windows, just a door, light bulb hanging from the ceiling on a wire. That's it.

Wilcock: Uh-oh.

Adair: And they slammed the door shut. And I'm sitting there going, “Man, I'm in bad shape.” And that's where Rudolph, on the way there, he just wanted to get his point in.

He says, “Just a minute. I want you to see something.”

So we go in this lab-looking thing. There's a cadaver laying there. Pulls it [a cover] back. "It's a 17-year-old male," he tells me.

And he goes, "We're going to change the dental records to match yours. We're going to burn this thing to a crisp and send it back to your parents saying that you were burned in an accident at White Sands, and you're going to stay here the rest of your life."

Now, this is a sociopath you're talking to.

Wilcock: Wow!

Adair: And that's when I . . . They locked me in that room, and I started crying. I'm only 17. I knew I was done.

Who is going to come and rescue me, you know? And Colonel Bell is meanwhile locked in his quarters at White Sands. But I found out he broke loose, overpowered the guards and called LeMay.

LeMay's en route to Area 51 right now.

And if you didn't know this, Area 51's under the command of SAC, Strategic Air Command.

Wilcock: Right.

Adair: So who appointed all the commanding officers? LeMay did. So he ain't asking. He's just flying straight in.

And I hear a lot of ruckus out in the hallway, and the door flies open, and all I see is a silhouette – big square shoulders and somebody doing this with a big stogie. [Puffing on a large cigar.]

And if you've ever seen any pictures of LeMay, you would go, "That's Curtis LeMay."

He's got hold of a tie. The tie is around a full bird colonel of the Air Force that he's been slinging back and forth. That's the banging I heard. And he was banging this colonel who's commander of the base. And he's so furious. He appointed this commander.

So all the commander knows, civilian or not, that's a four star Chief of the Joint Chief's got you by your tie.

And he looked down at me, and I'm just a mess. And he looked back at that colonel, and that colonel quickly said, "We had nothing to do with that. Rudolph and these other guys did."

He said, "Where's he at?"

"He just left."

"Find him! And get him cleaned up and put him on my plane."

And we flew from Groom Lake to Wright-Patterson Air Force Base. And they put me in the general's car and drove me back to my house in Mount Vernon, Ohio.

And that's how I spent my summer vacation in my junior year in high school.

Wilcock: Ha, ha, ha.

Adair: And when they asked me to write that up with . . . I'm a rising senior, went back to school . . .

Wilcock: "They" who asked you to write it up?

Adair: Oh, the English literature . . . "What did you do for your summer vacation?"

Wilcock: Oh! Ha, ha.

Adair: Well, I'm going to tell you, "Yeah! Well, I invented the fastest rocket on Earth, and I met this madman Nazi war criminal that's been riding me all the way, and I'm working with a four-star general, and I'm at a secret Air Force base, and I blew up the missile and . . . saw an alien power plant."

So I just said, "I worked at Pizza Hut."

Wilcock: Ha, ha, ha.

Adair: What are you going to say?

Wilcock: All right. Well, that's all the time we have for in this episode of [Cosmic Disclosure](#). I'm your host, **David Wilcock**, here with our special guest, **David Adair**. And I think you for watching.

Cosmic Disclosure: Timeline Splits and Diversionary Tactics

Season 8, Episode 4

David Wilcock: All right. Welcome back to “[Cosmic Disclosure](#)”. I'm your host, **David Wilcock**, and in this episode, we are here with **Corey Goode**, bringing you some very interesting up-to-the-minute updates.

So without further ado, **Corey**, welcome to the show.

Corey Goode: Thank you.

David: So let's talk about this first, because the first subject is one that is on a lot of people's mind if they're aware of what's going on, and that is that there have been a very densely concentrated number of incredibly snide, vicious personal attacks against me, but much more so against you, and even against this network.

I will just say, for the record, that I consider these attacks to be very over-the-top and ludicrous. And I don't typically respond to this kind of stuff because it's just so absolutely outrageous.

But what are your thoughts or feelings about what's going on right now? I mean, it's obviously made to look like it's just normal people having typical complaints, but what do you think is going on here?

Corey: Well, I've spoken to you; I've spoken to other people that have been in this business a long time. No one's ever seen anything near the magnitude of this type of attack.

And this is exactly what I said was coming at least six months ago, when I was told that anyone associated with the Navy Secret Space Program narrative had to be discredited and destroyed, because they want this Air Force narrative to come out and be disclosed.

David: The thing that surprises me the most about this, **Corey**, is the feeling of almost total invulnerability that the people perpetrating this appear to have. It's as if they don't have the slightest concern about being sued, or committing libel, or slander, or defamation. They just absolutely do not care.

What are your thoughts on that?

Corey: Well, as I stated, this is a part of a major operation. It's not just a few people that have some issues. These are people that have been activated, and they have to squash or quash anything that gives credence to the Navy program.

They only want the Air Force program to be in the forefront right now, because they plan to disclose it fairly imminently.

David: Would they be attacking you if you were losing?

Corey: Absolutely not. When you put yourself out as a victim, you are then in defense mode. You're not in attack mode, which is what they're used to being in – having the upper hand and being on the attack. Right now, they look extremely desperate with the tactics they're using.

David: You recently did a joint article with Dr. **Michael** Salla, and you've also made some Facebook posts regarding the idea that there could be some sort of official Nordic disclosure involving, I guess, something having to do with us being introduced to them.

Corey: Yes. And this could be tied to a recent meeting I had with Ka'Are. I've never seen her display anxiety with body language or energy, and I was picking up anxiety.

And she let me know that the Anshar were concerned about the timeline, that things were not going well.

David: Hm.

Corey: And that because of that, not only them, the Anshar, but three other non-human beings along with the Anshar have decided to go against the Muhammad Accords, which is a really big deal.

They're unable to get all the signatories of the Accords together to ratify it or to end it.

So because things have become so desperate, they are now stating that they're going to start reaching out to humanity.

And in the beginning, they're going to start reaching out to humanity en masse through dreams and visions to prep us for face-to-face contact.

And then they're going to start appearing, very much like they have with me, with individuals and small groups of people but not on a national or world scale to where they're going to be on television, that kind of a thing.

It's going to be a slow acclimation process.

David: I want to be clear on this, and I want to get you to put this on the record. What type of person would be chosen for this kind of contact? And what kind of conduct would these beings be expecting from you if you were going to receive this type of contact?

Corey: They're choosing people that they've been in contact with for a long time, usually, and a lot of these people spend a lot of time in a meditative state and are more in the frequency to where they can be communicated with.

David: Uh-huh.

Corey: So usually, it's going to be the more positive people, the quieter people, that have been focusing on their inner journey and have been preparing themselves for contact.

David: So just so that we're clear, what you're saying is then that these people would start by having, perhaps, a lot more vivid dreams than they'd been having before?

Corey: Yes, vivid dreams.

David: What might those dreams be like?

Corey: Communication dreams. Beings appearing to them in dreams and preparing them for face-to-face contact.

And when that face-to-face contact does occur, people could very well be receiving passes to ride along on motherships.

David: Okay, there's a couple more things I really want to get clear about here. It would appear that a more ego-driven spirituality would take something like what you're describing, and then somebody is going to want to portray themselves as a savior figure for humanity.

Corey: Well, there are going to be those, probably, who do that. But when you're one person among thousands that this is occurring to, you're not going to rise to the top to be any type of savior.

And they're not going to be choosing those types of people anyway that have savior complexes, they're just not.

David: What do you think will be the conditions in the world, or what have you been told will be the conditions in the world, that we will be seeing concurrently with when the in-person behavior starts to happen?

Corey: Well, a lot of people will be reporting these dreams – contact dreams. That's going to be the major thing that people notice.

Now, one of these four groups is most likely the Nordic group that I received briefings on for quite a while. Gonzales, Sigmund and Ka'Are'e have all spoken about this Nordic group possibly stepping forward.

This Nordic group has been in communication with all the world leaders, religious leaders, for a long time.

Recently, there was a meeting of all the world religious leaders, I believe in June, to where they all basically asked if we can just all get along. Isn't that right?

David: It was about, "Let's be friends", that was the main theme, yeah.

Corey: Right. Be friends.

Well, a lot of information is coming in – a lot of it through the Air Force – that this Nordic group has

been working very closely with the Vatican in a way to come out with their existence in a way that's not going to shock the people.

Now, they fully expect that everyone is going to have a lot of questions, you know, about these non-terrestrials.

And we're going to find out that they've been involved in our past for millennia, that they've appeared as angels. They have introduced different belief systems to try to manicure our consciousness, to get us to grow more consciously.

So it is very much expected that when we find out all this information, this group is going to give us, basically, their belief system, their religion.

And it's going to be based a lot on Oneness and what a lot of people would consider esoteric ideas, but it's expected that the masses, the massive part of the population, will adopt it very quickly.

David: So let's just say, **Corey**, that there's reason to believe that the Alliance may be very much more a factor in the Vatican now than ever before.

How does that reflect on this alleged disclosure plan you're talking about?

Corey: Well, the Alliance could be a factor directly or indirectly. Some of the people within the Vatican may see the writing on the wall, and they figure they'll make a whole lot of internal changes.

Maybe some of them have been fully briefed on this non-terrestrial group that's going to be introduced, and they want to clean house before that occurs.

So there could be a number of reasons on why the Vatican is behaving the way they are.

But the fact that open discussion . . . And I've heard from other people that they're hearing similar things about the Vatican coming out, announcing a human-looking ET group that is going to introduce a lot of interesting new ideas to humanity.

David: Now when you said before that four groups were planning on breaking the Muhammad Accords, I believe you said the Anshar was one of those groups?

Corey: Correct.

David: So do we know if any of these four groups would be a malevolent group?

Corey: These are positive groups.

David: Oh!

Corey: They have all worked together in this confederation. Four of them have decided to step away from the Muhammad Accords and then start to acclimate people for face-to-face contact.

David: How do you think that affects the overall plans for this partial disclosure that you've been sharing with us in the past?

Corey: Well, it affects it pretty heavily because the partial disclosure was going to start off with releasing information about ancient underground structures under the ocean and under the ice in Antarctica.

Then they were going to release the Secret Space Program that the Air Force and DIA control.

David: Uh-huh.

Corey: And at that point, then they would say, "The telemetry from these technologies has found even more under the oceans and under the ice. On that note, we happened to have found some of these structures on Mars," for example.

So that's how they plan on stepping things up.

Part of that narrative was going to be that ETs have visited the Earth, but hadn't been here in thousands of years, except for maybe one or two here and there.

And that narrative will be heavily stepped upon if a Nordic race or human-like race has open contact and begins, at the Vatican, standing next to the Pope, speaking to people.

David: Do you think, or have you been told, that this could happen quite spontaneously with the world just like it is today as we're taping? Or could it be in an aftermath of some sort of catalytic events?

Corey: There are a lot of events that are expected to occur in tandem with any of these disclosures.

As I was discussing, the military-industrial complex wants to start with ancient civilizations under the ocean and under the ice.

Well, they could drop that at any point.

What they're going to do is use that as a diversionary tactic if there are any types of tribunals or arrests that start to occur. That's going to be a major diversionary tactic that they plan on using.

David: I would assume then that these would be very impressive.

Corey: Absolutely.

David: How would you describe something as being more impressive than typical tabloid stories we've seen up until now?

Corey: Seeing actual video and actual telemetry instead of speculation. You'll see . . . Like off the coast of Cuba, you have some sonar of ancient structures, but it was real hush-hush, after that.

David: Yeah.

Corey: These are going to be undeniable reports, and it's going to be sanctioned reports, that are going to give you all the information that they've gained from investigating them.

And this is going to include some of the underwater sites and under ice sites.

David: Have they war gamed what they think people's reactions will be to this?

Corey: Yes.

David: What are they expecting will happen?

Corey: Well, they're expecting it to be a good diversionary tactic, but they also had originally planned to release this information, and eventually release the information that the beings that created the

civilization under the ice were not human. And that these elites are part of the bloodline of these beings, therefore, they are special. That was one of the narratives that was going to be pushed.

They were going to push their religion, basically, on the rest of the world using these finds to back up the religion.

David: Well, you remember, **Corey**, that right before you and I started talking, I got this “authorized disclosure” from the United States government from one of my insiders that was the whole cosmic history of the Mars and Tiamat, or Maldek, civilization 500,000 years ago – blowing themselves up, going to the Moon, eventually crash landing here on Earth and becoming these Pre-Adamites.

Corey: Correct.

David: So do you think that that Pre-Adamite storyline is part of this idea of the elite being gods that they wanted to portray?

Corey: Yes.

David: How would that work?

Corey: Well, they are able to trace their bloodline back to this non-human group, the Pre-Adamites. So, therefore, it's like the “divine right of kings”. They're going to say, “Look at this vast civilization, what they were able to do. Why not give us control? We're the same bloodline. We have all of their information. We can implement something like they had that's technically advanced and a society where everyone can live together.”

David: What do you think is the goal of the Nordic group that's doing this? What would be their ultimate objective for throwing off this partial disclosure timeline? What do they want from this?

Corey: They want to prevent a timeline that they have seen to where there is open negative rule – open rule by negative ETs.

They have seen timelines to where there is open rule by Reptilian-type ETs. They're seeing different divergences in the timeline and how things are going.

So they've gotten to a point to where they have decided that they have to have all hands on deck and begin to have a hands-on approach instead of more of a remote approach, like they have been doing.

David: So you're saying there is a possibility that these benevolent ETs see that even where we are right now, with as much awakening as we've had, that we could actually have a Reptilian-dominated planet?

Corey: That is one of the concerns, yes.

David: So what could we do to prevent that timeline from taking place? And what haven't we done? Why would they see that it would even exist?

Corey: Well, I believe that they're seeing now that there is so much interference from the negative groups. There are these cosmic laws to where you can't directly interact with a developing society. You have to do it more in the background with puppeteers, secret societies, that kind of thing.

David: That's both positive and negative sides, right?

Corey: Right. Well, the positive side finds ways to skirt these cosmic laws. The negative side will skirt the laws very well, but they'll also outright break those laws.

David: But in both cases, we could say that each side has to contact people who are willing to follow their agenda, . . .

Corey: Right.

David: . . . whether it's a benevolent agenda or an evil agenda, . . .

Corey: Right.

David: . . . and then work by proxy through those people instead of appearing directly.

Corey: Yes. But the negative groups have had more of a hands-on approach for a long time, and it's caused a lopsided battle. So a lot of these positive forces that stick very closely to these cosmic laws are starting to get more hands-on.

David: Okay, so then people who are watching this show would ask, if the benevolents are so worried about this, then why don't they just show up right now? Why are they so worried about coming forward and breaking their treaties and all this kind of stuff? What's all the fear about?

Corey: Well, they still have to do things in the proper way. They can't just appear in the skies. They have to go through a process like I discussed, where they're going to start acclimating people through their dreams, appearing to them one-on-one.

That is the proper way to introduce themselves instead of just appearing in the skies.

David: **Corey**, apparently, Ka'Are and some of the other Anshar have told you that the stakes for them are very, very high in this battle about whether we get this negative timeline or not.

So could you explain why the stakes are so high for them?

Corey: Well, as I've stated, the Anshar disclosed that their lineage is actually from our future. It's kind of a hard thing to . . . It kind of twists your noodle a little bit.

They had something in their present, which is our future, that was similar to the Mandela Effect, which made them start looking back through time.

They located the cause. So they sent a group back, a small group, to maintain the timeline. And they sent them back about 17 million years.

So they've been here that entire time and have developed out independently. And it went from a small group to a pretty good-sized civilization that lives below the Earth.

Now, if they are not successful in maintaining their timeline, they could blink out of existence.

David: So they would not have existed before nor exist in the future?

Corey: They would not exist in the future, therefore, they would not exist in the past because they would not have had an opportunity to travel to the past to try to maintain the timeline.

David: Very bizarre.

Corey: Very bizarre.

David: Tell us what has happened, any updates you can share with us regarding the disappearance of Sigmund, since he was a major figure in some of our recent updates.

Corey: Yeah, I believe it was in April that he disappeared. And strangely enough, around that time period, a few other Air Force-type connections disappeared for other researchers. It was very bizarre.

Now since then, I've had a few meetings with the airmen that I call Tweedledee and Tweedledum, that . . . Some of them were kind of contentious.

In the beginning, they were very interested in knowing if I had heard from Sigmund, if I knew anything about Sigmund. And something felt a little off. I didn't know what was going on.

Then most recently, in a meeting, these airmen hand me this report that they say was penned by Sigmund.

And in the report, it kind of contradicts a lot of the conversations I had with Sigmund. It says that they did not find any signs of a Navy Secret Space Program, even though he had interrogated some of these people himself.

So that, right away, got my attention.

And then the report started going down the line, stating that there are no giant spheres that came into our solar system, that all of this is a Nordic deception, basically, is what they were trying to tell me.

David: What about the Blue Avians?

Corey: The Blue Avians, they believe, is a creation of the Nordics. They believe the Nordics also created The Law of One. That was all in the report.

David: Interesting.

Corey: So they're giving me this report, and I'm looking at it, and my spidey senses are going like crazy. You know, something's just not right. And they're observing me very closely.

Furthermore, the last time I had seen them, they started, I guess, pooh-poohing a lot of the intel I'd been given by Sigmund on Antarctica, on certain dates when things happened in the cosmos.

It was as if they were trying to disinfo me real quickly. And I felt a lot of deception coming from them. They were watching me, studying me, seeing how I would take in the information.

In the same conversation, when they were talking, I was picking up that Sigmund really wasn't missing. I was getting the feeling that he was actually trying to infiltrate the SSP Alliance.

David: The Navy one.

Corey: The Navy. And I just stopped and went, "Oh!" I said, "Sigmund is trying to infiltrate the Alliance!"

And they lost their composure at that point. And they said if I stated that publicly, that my family would be harmed. And the last . . .

David: You got a threat from them?

Corey: Yep!

David: Really?

Corey: And that was before my last trip here to Gaia to do a report, and I left that out of the report.

David: So define "lost their composure." They literally started yelling?

Corey: Yes.

David: And angry, violent faces?

Corey: Visibly angry.

David: Really?

Corey: They also told me that under no circumstances should I discuss the R&D facilities in Antarctica.

I've received a briefing on those, further briefing. They are EXTENSIVE! It is huge.

And also, the spaceport down there, they do not want us discussing.

They want us to go full bore and discuss the ancient civilization stuff, because that goes along with their narrative.

It's very problematic, the information about what is going on down in Antarctica with these various contracting firms.

Anything that's illegal to do or immoral, they're doing it down there in those facilities.

David: Why do you think they care so much about what you would say or what I would say if most of the people in the world don't believe any of this anyway?

Corey: Well, they do not want ANYTHING circulating about the R&D bases down there because it's against a 1959 treaty. There could be a lot of negative ramifications, even though I hear other signatories of that treaty are doing similar things down there.

So this is a major black operation area, Antarctica is.

David: Hm-mm. What do you think is the end game for these two airmen in threatening you that way? Obviously, you're not listening to them because you're putting it here on public record.

Why would they threaten you so strongly? What are they worried about? What's their vulnerability?

Corey: They want to steer me into reporting only the Air Force narrative, and everything they're doing is trying to guide me in that direction.

If I cannot be guided into that direction, then the next stage has to occur to where they completely discredit me or anyone else reporting the Navy narrative.

David: I'm kind of going to fish here, but I think it's a valuable fishing expedition. Is there a relationship between this Reptilian-controlled planet timeline and the partial disclosure timeline?

If they're trying to steer us towards a partial disclosure timeline, is that the gateway drug for this negative takeover of Earth somehow?

Corey: When the timelines split, there has to be a point from where they split. And depending on if it's the negative timeline, positive timeline, or anything in between, it's going to bifurcate at a different point.

So they're going to try to control when that bifurcation occurs by controlling our mass consciousness. Our co-creative mass consciousness has a huge effect on these timelines.

So that's one of the main reasons why we've been so mind-controlled.

David: Have you had any further interaction with Gonzales since we last put up dates out here, and if so, what has happened?

Corey: I meet with Gonzales every one to two weeks. He's been helping manage the temporal dementia-type issues that are bleeding through, and also the two other 20-and-back bleed-throughs that are occurring.

Ever since he started treating me with that Magic 8 Ball thing, I started having dreams and flashbacks from the other 20-and-backs.

And most recently, I had a situation to where all of a sudden, I felt a little sweaty and nauseated, and was feeling outside of my body.

And then the next thing I know, I'm in some sort of a like an NBC-type suit or some sort of a protective suit. And we're walking through this area that looks almost like a cave, but it looks like an ancient facility in this cave.

And we're walking through. I can hear water dripping. And all of a sudden . . . It was just moments. And all of a sudden, I start leaning against the wall, and I'm feeling all dizzy.

And one of the women that was there grabbed my helmet and is looking at me and trying to communicate with me and looks over to someone else and starts saying, "It's happening again! It's happening again!"

And then I'm back, myself, current timeline, trying to make sense of what had just happened.

David: Hm! So you believe that that experience that you just recounted was from one of your 20-and-backs?

Corey: Yes.

David: And this would imply that some sort of degradation of your health or mental condition was taking place as a result of what they were putting you through?

Corey: Yes, but also the last 20-and-back was reported to be around the 1997 time frame.

David: Oh!

Corey: And we're, what, 20 years out from that?

David: Right.

Corey: So like I've stated, a lot of the 20-and-back people start realizing that they were in 20-and-backs, or suspecting it, usually around the 20-year period after they've been released.

David: Is that where these bifurcated timelines start to knit back together?

Corey: After that 20-year timeline is when a lot of people start having memory recall, for some reason, of their service.

David: Interesting. Can you speak in a more knowledgeable fashion about the rough categorization of your three 20-and-backs now? Do you have an ability to say, "Okay, in this one, I actually worked Solar Warden. In this one, I did intercept and interrogate. Has it gotten that specific yet?

Corey: No, no. I was just having flashbacks of moments. And, apparently, the last two 20-and-backs were . . . I was involved with some pretty dark activities. So . . .

David: Okay. This is like galactic slave trade-type of stuff?

Corey: I'm sure it probably does.

David: Would you just say, on a general level, that the space program is designed on purpose to put people into what we would call evil or unethical situations so that no whistleblower could ever come forward?

Corey: Well, that's one of the main reasons I've seen so many other whistleblowers walk right up to the line and not cross it. They do not want to self-incriminate. These are a lot of dark things that occurred, and there are a lot of people that could come forward and give a lot of information, but they're afraid of incriminating themselves.

David: Could you be at all specific about the nature of how you would meet Gonzales? Is it similar to a construct like with Ka'Are? Does it involve the Mayan breakaway type of method?

Corey: Yes, the Mayan breakaway. They basically teleport or transport me up to a vessel that they have in orbit.

David: Hm. So the way in which you're seeing Gonzales in these meetings is in a Mayan vessel.



Corey: Yes.

David: Are you interacting with anyone else when you're there besides him?

Corey: No, just him. The Mayans will look at me and smile real warmly, but I have, still, to this point, never had an interface with one of them.

David: Do these meetings typically happen in the same room or the same location?

Corey: Yes, the same room that I've described before with the floating stone panel, flashing Mayan-type symbols.



David: So was there anything further that you had from Gonzales that you feel is of importance to share with us right now?

Corey: Yes, actually. Quietly in the background, he has been in contract with elements of the Secret Space Program Alliance. They've been keeping their heads down big time after Sigmund's group appeared. Now, he's been starting to give me briefings again, that are briefings that the SSP Alliance has asked him to give to me.

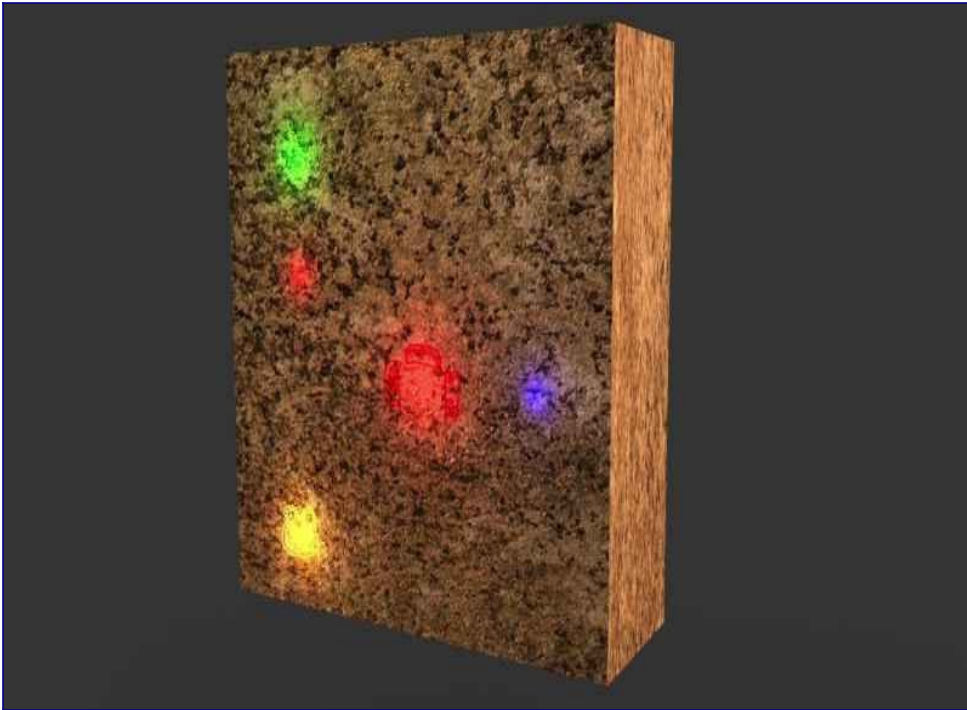

Now, this has included information about current events going on on the Earth.

On “[Cosmic Disclosure](#)” not too long ago, I had described how different military cells had been spread out throughout the United States before the elections to monitor some of these Deep State-type organizations and assets.

David: Hm.

Corey: Now, I found out more recently that these are Special Forces cells – I can't say which branch – that these people, these soldiers, are the ones that had been sent to Kosovo, and places like that, to gather evidence [of] crimes against humanity.

David: Hm.

Corey: It's not really legal for them to be doing domestic investigations, but they are. And they have identified all of the negative groups. They've been looking into the corruption. They've been looking into ties to very dark secret societies and activities tied to those, which we won't go into details on. And they've identified all of these people.

And this military faction is waiting for a go-ahead to arrest these people. And they don't expect it will be unless there is a military coup, because from the information I've received, the Deep State is in a

place right now where they're about to pull a few operations to remove some of the leadership that the Alliance has seeded into the United States.

When this occurs, if this occurs, I was told that the military groups that have been planning a coup will enact a coup, and that these Special Forces soldiers are gathering information for tribunals after something like a coup occurs.

David: Well, given the fact that these plans have been on the table for a long time, why do you think it's taken us so long to actually have this happen?

Corey: Well, as I stated before, the Cabal groups were using this probable future technology that are AI algorithms that detect probable futures. This is how they've been able to stay out of the path of any type of arrests.

Now, a lot of the arrests that have been hyped up in the past have been just hype, because strategically, there was not a situation to where the arrests could ever . . . The arrests could not occur because the Department of Justice was so controlled by the Cabal, as is the Congress.

The whole government is basically controlled. So there was never an opportunity to where anyone would be able to order arrests. It just wouldn't happen. They could order arrests, but no one would carry them out.

David: Right. How do you feel it's changed now?

Corey: Well, it's changed now because the Alliance has stepped up their operations in the last few years, especially. And all the signs point to the Deep State, or Cabal, being now in a defensive position instead of an offensive position.

So a lot of the Alliance groups that are loosely knit are seeing this sign of weakness, and it's emboldening them to apply more pressure to try to bring down the Cabal.

David: So if there were to be some sort of massive joint maneuver, how do you think we would encounter that as people who are just citizens?

Corey: Well, there would be a media blackout at first, until the hostilities had ceased. And then the military would take over the airwaves and give a full explanation of what had occurred. That's what I'm told.

David: And you feel that this would be a benevolent thing?

Corey: I think that the Alliance feels it would be a benevolent thing. The people that are in control right now are the personification of evil – the things that they do.

David: Right.

Corey: I don't even have to leave it up to people's imaginations. It's all over the Internet.

David: Have you had any further interactions with Blue Avians, and if so, what has been the content of that?



Corey: Yes. About five weeks ago, I finally had an encounter with Tier-Eir. I was picked up from my living room by a Blue Sphere, brought to another giant Blue Sphere, as I have had in the past, and I

conversed with Tier-Eir.

And he showed me the solar system, and all of these spheres were pulsating and almost completely transparent.

And he told me that soon they will fade, and the full brunt of these energies will hit humanity.

When that begins to occur, do not be afraid when we begin to see large clusters of earthquakes, volcanoes going off, storms becoming even more energetic and dangerous - that these things were going to be a part of it when we get the full impact of these energies.

David: Is that the solar flash? Or is this just an energetic change that's preceding . . .

Corey: It's the energetic change.

David: Okay.

Corey: And I was told also that the End-Time Madness-type stuff we're seeing, where negative people are becoming very negative, positive people are becoming more blissed out, and we're seeing the mentally ill people just lose it – a lot of mentally ill people just lose it – that that is going to occur exponentially, and it's going to become a lot worse.

David: Hm.

Corey: So because of this End-Time Madness, we can expect to see more rattling of sabers and talk of war, and that kind of thing, which can be very fearful.

But what Tier-Eir was trying to communicate to me is that we should not be afraid because we will feed that beast, that we should be hopeful because these are signs that the great changes are about to occur that are going to give us this consciousness renaissance.

David: If in Law of One terms, if we take The Law of One as being real and that these beings are all represented in it, we would have the Blue Avians being two dimensional levels more advanced than the Anshar.

Do they have the same degree of concern about our future that the Anshar do, or are they more dispassionate?

Corey: They're dispassionate, right.

David: Okay.

Corey: Yeah, I'm not sensing any type of . . . You don't sense any type of ego at all. They're more like a social memory complex that one of them is representing at the time.

It's not the ego of one being that identifies herself as that name. It's a different type of communication with them as opposed to the Anshar.

David: Did they give you any warning about a possible negative timeline for Earth?

Corey: Yes.

David: They did?

Corey: Yep. Yeah, they did state that we need to work harder, doing mass meditations and doing everything we can to try to co-create this positive timeline. That the way our consciousness is being manipulated now, that we're headed, not necessarily to the bottom of the scale, negativity-wise, but somewhere in the middle.

David: Hm.

Corey: And if we get stuck somewhere in the middle, this next cycle is going to occur. You know, who knows what that's going to mean for humanity.

David: Do you have any further information to share with us on these large motherships that we've talked about in the past that have been found in Antarctica and have been excavated over the course of many years?

Corey: Yes, actually. I received, basically, a fairly decent briefing on the R&D facilities there that they really don't want me to talk about, as well as more information about, especially, the three original craft that were discovered on ground level beneath the ice.

There were three oval craft, one very large, two smaller. They're the ones that they jokingly call the

Nina, the Pinta, and the Santa Maria.

They arrived at the same time and positioned themselves in a triangulated position on the surface.

And then the beings that were in the craft then began to cannibalize the craft to create a city between them.

David: And this was, I believe you said, around the time of 500,000 years ago – the original one?

Corey: No, this occurred around 60,000 years ago . . .

David: Oh! Okay, that's the more recent one.

Corey: . . . when they came here and crash landed here.

David: Okay.

Corey: But they already had an enclave down here since before Tiamat and all of that in that area.

David: Right. But when you say “ground level”, do you mean . . .

Corey: Under the ice.

David: So it was on ice?

Corey: No, it was on the dirt, . . .

David: Okay.

Corey: . . . and there were trees, plants. They landed amongst all of that.

David: Okay.

Corey: They created a society, a civilization that rose pretty high. And one of the things I discussed is that they were really big into genetic engineering. They would mix their genetics with the humans' genetics and the different animal genetics.

One of the things that I mentioned when we first talked about this was that in one of the genetic labs,

they found a very strange Reptilian being that was in different stages of development. They were small and larger.

David: Hm.

Corey: And what I'm wondering is if the recent discovery of the three-fingered mummy from Nazca, if it could be one of these Pre-Adamite experiments.



I'm also wondering if . . . We've heard the Draco complain about . . . there were three lost Reptilian races from the Earth that humanity had destroyed a lot because we were told to by human-like Ets.

And so they blame these human-type ETs and humans for removing their genetic experiments from the Earth.

David: Hm.



Corey: And I'm wondering if possibly that these two different types of beings that have been reported by Gaia are two of the three lost races.

So I have an inquiry out on that, and I'm waiting to hear back.

David: For the record, what is your personal feeling about the mummies that have been shown on “Unearthing Nazca”?

Corey: It's mind-blowing! I think a lot of people had a knee-jerk reaction or it threatened their belief system so much that they just had to say, “It's a hoax! It's a hoax!”

But when you look at the X-rays, you can see that that's anatomy.

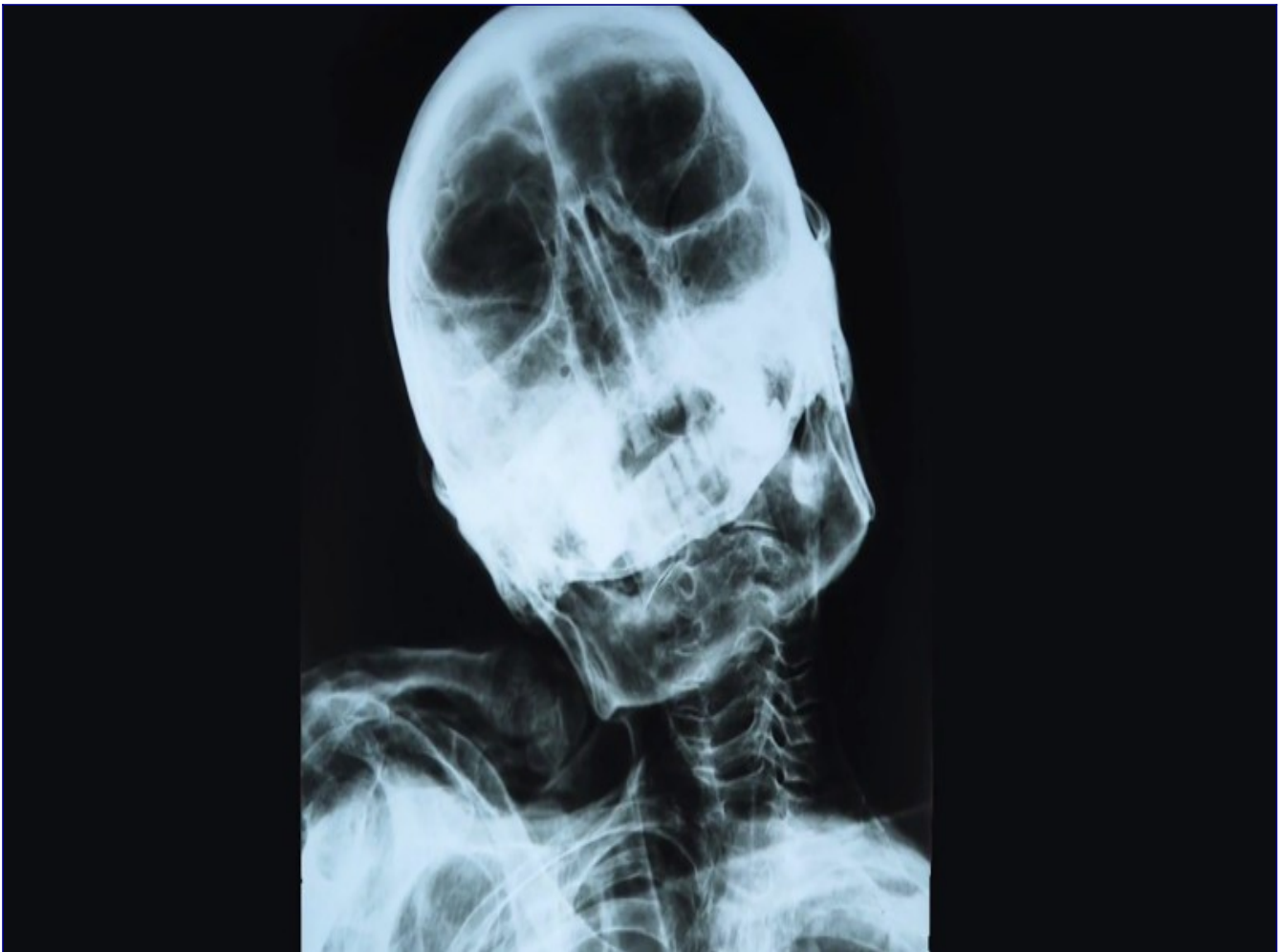

Those bones grew together.

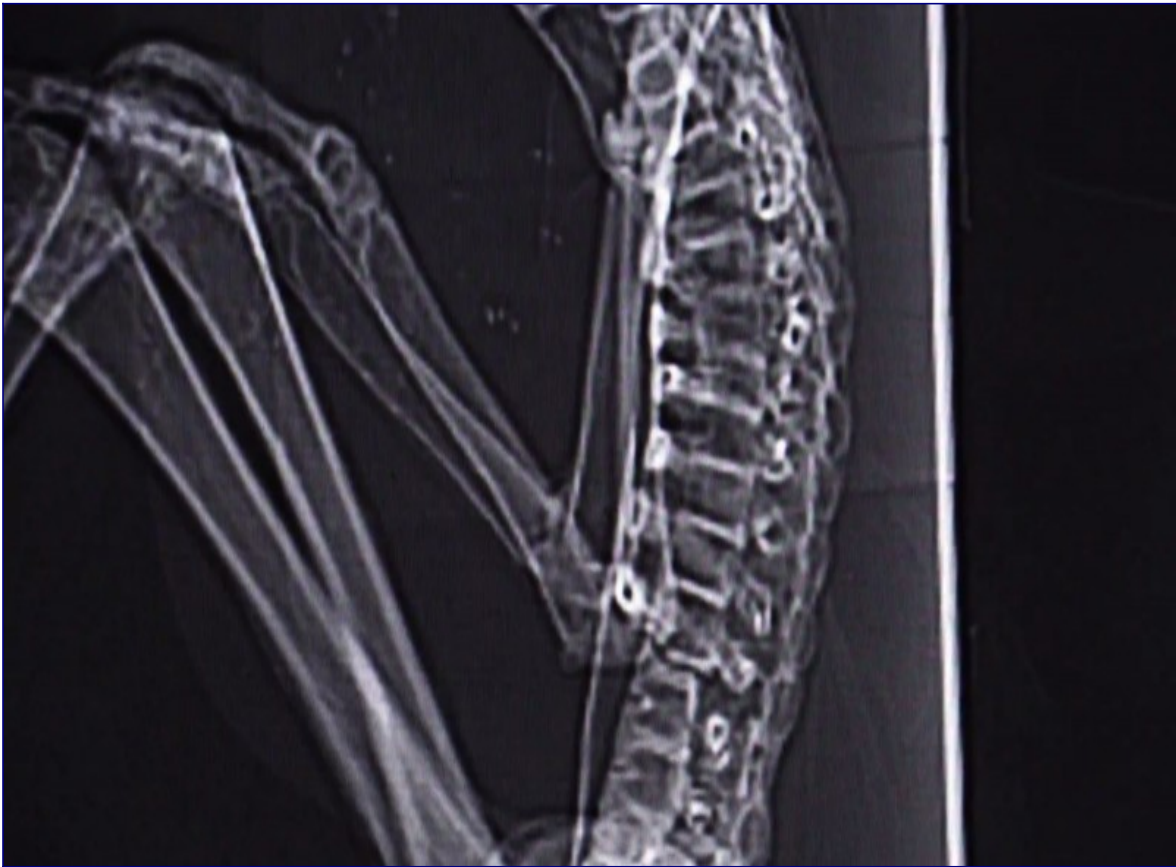

So I can't see how it could be a hoax myself. I mean, if it is, why would someone go through all of the trouble to create a hoax like that? It would take so much time and money. What would their goal be?

So I can't wait to get back the genetic report to take a look at that, to see if there's reptilian, human and unknown DNA in it. Or if it's reptilian, even maybe some avian DNA.

David: Have you ever seen, in your own travels, any three-fingered extraterrestrial-type beings?

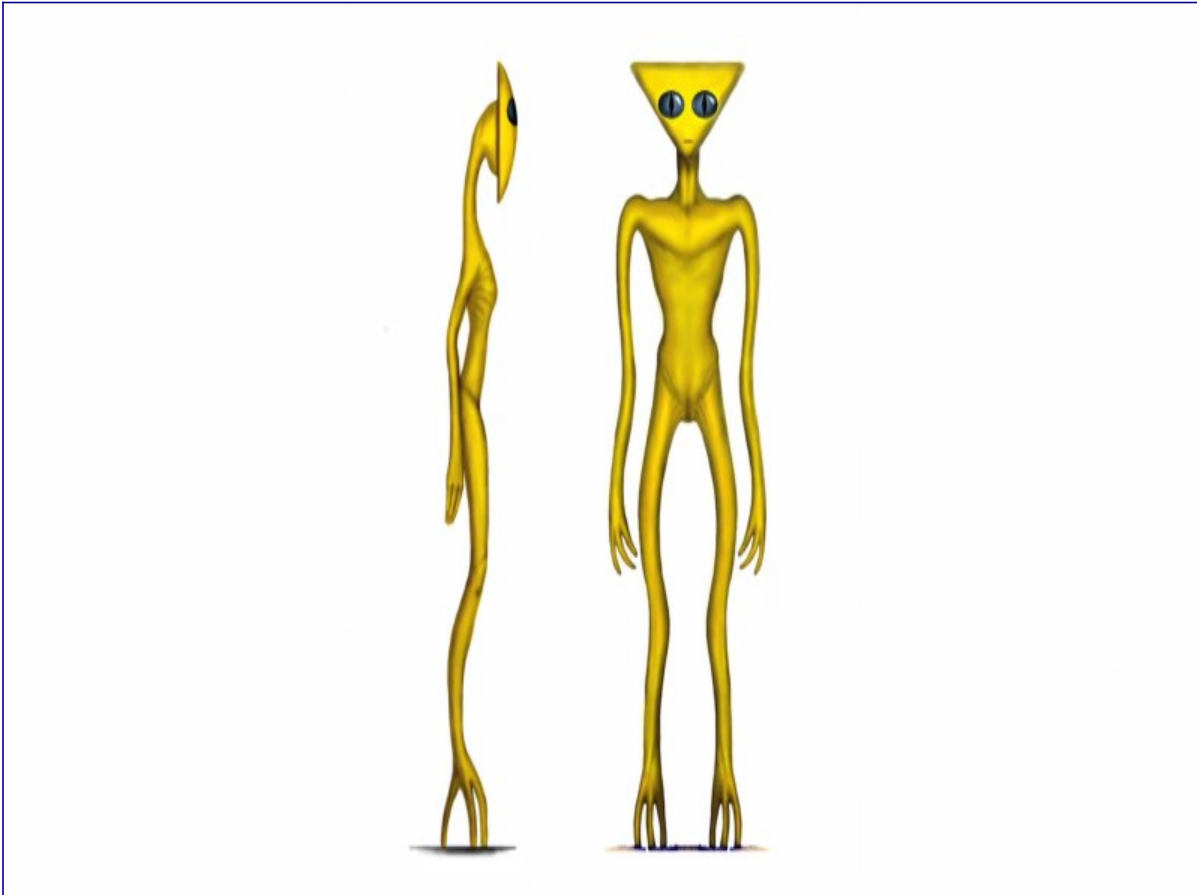

Corey: Well, yes, the Golden Triangle-Headed beings are three-fingered. And there are also other . . . It's kind of rare. Three-fingered beings are not common – three fingers that are just very easy to move around, and that they're able to bend around in all kinds of weird ways.

But most of the beings that have been reported have either three fingers and a thumb claw, five fingers, or six fingers.

And our planet produces a certain harmonic field. And that field interacts with DNA, and it creates a template. And one of the templates of our planet is that most beings have five fingers.

David: So do you think that there would be energetic modifications to an extraterrestrial's DNA if it lived here long enough, based on those native vibrations from the planet Earth?

Corey: Yes, yes. Some people call this Schumann Resonance, or whatever, but the frequency that the Earth puts out is going to have an effect on any being's DNA that is here long enough. It's going to begin to change the DNA.

David: How do you think that the Solar Flash events affect DNA as compared to the sort of ground state that we're in, in between them?

Corey: Well, it's definitely got a . . . Just exposure to the Sun alone has an affect that changes your DNA. So that type of an energetic explosion from the Sun is going to have a very huge impact on our DNA.

Like I said, it depends on what you think the Solar Flash is. A lot of people think that we're going to be hit with all these particles, and we're all going to get cancer, or we're going to die very quickly from exposure to these different radiations.

And some people think that there's going to be some sort of spontaneous Ascension.

I think the truth is really somewhere in between there. From what I've been told by Tier-Eir, what's going to occur is going to be more of a change on a consciousness level that's going to send us into a consciousness renaissance, like Mika's people went on.

And in that consciousness renaissance, we begin to understand how to manipulate time and space.

David: Very good. All right. Well, that's all the time we have for in this episode of "[Cosmic Disclosure](#)". I'm your host, **David Wilcock**. We're here with **Corey Goode**. And I want to thank you for watching.

Cosmic Disclosure: Remembering William Tompkins - Disrupting Draco Domination

Season 8, Episode 5

David Wilcock: All right. Welcome back to “[Cosmic Disclosure](#)”. I'm your host, **David Wilcock**, and I'm here with **Corey Goode**.

Now some of what we're going to cover in this show has been covered before, but here's the key. We're talking about something that is very real.

The REAL reason why we're doing this show is not entertainment. It is disclosure.

And by talking about these things and exploring them in more detail, we are helping to crack the lid on something that's actually a very serious problem.

And so for that very same reason, in a topic like this, we need as much information about it as we possibly can get. And the more information we have, the more powerful our tools become to be able to stop these horrible things from happening.



GALACTIC SLAVE TRADE

William Tompkins: It's very strange that this has been going on, that the same structure of a medieval country – kings, queens, princesses, all of the top people – agreed with maybe France's or Spain's group, and they became the elite. They became the control of the population in their countries and were never allowing the people a real life, never allowing them to participate in many of the other things, and many of them were actually slaves.

So the big slavery business out there is a big business. It's a major business today – a massive business.

Anything that you want to manufacture, anything that you want to farm, anything that you want to build, it's all done with slave people.

In Germany . . . Germany had massive underground facilities that were all slaves and even to the extent that when the decision was made before the war ended that they were going to continue all of their extraterrestrial developments on UFOs and on every weapon system that they were building, they took the production facilities to Antarctica, but they also brought the slaves with them.

So now there are slaves underneath the ground and they still are today in Antarctica.

But the slave business out there is a big business, and this is happening today. It's not something that happened 100 years ago. This has been going on a long time and that needs to be fixed.

There's all kinds of slavery. There's sexual slavery, unbelievably. There's many different classes of people that are abducted for slavery, sexual slavery. They want the top and the smartest, because they are worth more.

They have, I think, four or five different levels of people that they abduct. They abduct top medical research people. They abduct the corporate levels, and they abduct the most brilliant levels, and then they go down through the three levels and that says where they get sectioned off.

Everybody gets to two planets and then it's decided where they're going to be sent to. But it's a massive business. It's been going on for years, and we can't identify where these people have gone.

Just like 'normal' abductions, we don't know where they went, because most of them don't come back. We're only hearing from the few that came back.

* * * * *

David: Whew! So as we can see there, this is some pretty intense stuff.

We have quite an interesting perspective on this because, of course, if you've been watching our show, **Corey** has had experience with this himself. He also discussed it when he was on with George Noory.

So, **Corey**, welcome to the show.

Corey Goode: Thank you.

David: Now, let's just start off by saying I know that you're very uncomfortable about this topic. Why is this so upsetting to you, this topic?

Corey: Because I saw it firsthand. It's a very upsetting topic. If it sounds like fiction, it's upsetting enough, but when you hear someone else corroborating what you've been through, what you've experienced, it brings a lot of the anxiety, a lot of memories come back.

David: Well, let's start to talk a little bit about what **Tompkins** had to say in the video footage. First of all, he seemed to be talking about traditional Cabal countries, France, Spain, England, and slave trades that they had going back for generations.

So there was a little bit of an "Illuminati" thing there, because he was mentioning royal families that all got together and were secretly collaborating even though their countries appeared to be fighting with each other.

Did you ever get to hear about that kind of stuff – the Game of Thrones sort of politics, the occult elite?

Corey: Yeah, we were very curious where these people were coming from, how they were acquiring them, and it turned out that they were using this multi-generational infrastructure for slavery that they had built just for here on Earth.

David: REALLY?

Corey: Yes, and it had never stopped. The human slave trade on Earth has never even slowed down really.

David: So just to make sure that I understand what you're saying, the exact same systems and the management structures and the coordination of how these Cabal or Illuminati countries were doing it back going 100s of years, it just continued directly through to this galactic slave trade involving extraterrestrials.

Corey: Yes, to present time.

David: I know I've asked you this before, but for the purposes of clarity for today, how long have extraterrestrials been grabbing slaves off of our planet?

Corey: As long as we've been on this planet.

David: Did they have the collaboration with this slavery mechanism from the Cabal countries in the past?

Corey: I know it's gone back some time, but I don't know how far back, how far it goes back, that the Illuminati groups, if you want to call them that, were using the people in the field that go scouting for people to kidnap, give them a list of what you're looking for.

Those people do the kidnapping, bring the people that they had abducted to a central location where they are basically treated like cattle, sent down different . . . go different directions, you know. This person will go off-planet. This person will go into the underground sex slave trade.

David: **Tompkins** mentioned that there were different types of delineations of who is picked and for what purpose. He mentioned farming. Could we start with that? Talk about what type of farming would these people be doing if they were being brought for that purpose.

Corey: Well, they will raise food for people in the program kind of like hydroponic-kind of setups on other bodies in this solar system . . .

David: Hm.

Corey: . . . where they grow food. And they do have people . . . They'll get people that do construction. They'll go and they'll take these people and then take them off-planet and force them to do these things.

David: How would they prevent these people from trying to put poison into the food supply or doing something to sabotage the operation? If you're a slave, you're not going to be happy about it.

Corey: No, but the way they treat these slaves . . . I mean, you have NO HOPE of ever seeing home again. They treat them just well enough to where they want to survive, they want to stay alive, but bad enough to where they will follow any worker.

David: **Tompkins** also mentioned manufacturing jobs. Can we talk about that a little bit? What types of jobs might they have?

Corey: Sure. I'm sure everyone remembers me discussing the manufacturing plants on Mars . . .

David: Yeah.

Corey: . . . to where they would have tens to hundreds of thousands of people living close by these manufacturing plants to where they were being sent in trains to these plants to work.

And this is going on on other bodies in our solar system as well.

David: So are they actually going to do high-technology stuff?

Corey: Oh, yes. They're building things that non-terrestrials are coming here to trade for.

David: Right. Is a significant majority of the workforce that they have for things like the ICC all actually abducted slaves?

Corey: There are abducted slaves and people that go and apply for a job. They get a job, they're happy, they go to work, and then become a slave.

David: But you've also described in other episodes that there are plenty of extraterrestrials who are not going to be local to our solar system, and they are also picking up slaves for a variety of different reasons as well.

Corey: Uh-huh.

David: And we may have no idea what those people are doing.

Corey: How this really all turned into such a huge trade is that in the beginning of when we started having contact with non-terrestrials, we were allowing them to abduct humans and take humans. There were so many humans that were never coming back.

So the very morally bankrupt people in this Cabal, decided, "Wait a minute. If we can hold off the non-terrestrials, we can trade these people for technology."

David: What is the estimate, or if there is a sliding scale of estimates, as to how many people per year are being brought into this?

Corey: Well, I remember this statistic for worldwide disappearances is like a million people.

David: And if that's happening every year, it could be very sizable.

Corey: Yes, yes, it's . . . Millions of people have been taken off this planet.

David: So we could literally be talking about many millions of people who have been brought off this planet into this world in various ways.

Corey: Yes, that are being brought into the slave trade. And you also have to remember that the people we were just talking about that lived on these . . . that are slaves on these Mars facilities, they, over the decades, have begun to have children, and these children are born into slavery. So it's generations of slaves [that] are up there.

David: And **Tompkins** corroborated a lot of things that you've said very precisely, including this idea of like a brain drain or different echelons, different tiers, of people being brought in.

Corey: This is one of the biggest topics that the Cabal doesn't want anyone to know about. This is one of the things, if we have Full Disclosure, and people find out about all these crimes against humanity, it's going to be a CRAZY DAY on planet Earth.

David: Well, let's say that happens. What is the carrot that we have to look forward to with all of this? Is disclosing it actually going to stop it? I mean, aren't we turning our backs on these people if we don't talk about it?

Corey: Very much so. A lot of people that have been involved or have firsthand knowledge of this don't want to talk about it because of the huge amount of shame involved.

You know, they have sociopaths that are doing a lot of this work, so, you know, they don't lose any sleep. But other people like myself that get drug into it, we're tortured. Inside of us, we're tortured for the rest of our lives.

David: I'm sure. One of the things that, obviously, we don't want to get too specific about it, but something that we haven't mentioned before, is the idea that there is a sex trade going on.

Corey: Um-hum.

David: What do you think is the purpose behind a sex trade and slavery in that sense? What's the objective here?

Corey: For these humans serving in the darker side of the Secret Space Programs, and for non-terrestrials, to be able to have sex. I mean, it's . . . They like to dominate, and that's a big turn-on for these sociopaths.

David: Hm.

Corey: So, I mean, it's, I guess, the oldest story in the world when it comes to talking about sex.

David: So this is very similar to the kind of sex trafficking that we've heard about on Earth where somebody could get brought into this world and, for whatever reason, they will work as a prostitute even though maybe they could escape. They're not going to really try to escape because they're kept under such tight control.

Corey: Yeah, there's no escaping. I mean, there's no escaping. You're . . . If you're on a tin can floating through space, where do you go? If you're on another planetoid somewhere in another solar system, what do you do? I mean, you have no hope.

David: What have you been told – and I know we've covered this before, but I think it's important to give people some sense of hope in this subject – what have you been told is going to occur as we end up freeing ourselves from the control of AI and the Draco and other negative groups? How will that affect what's happening to these people?

Corey: A while back, some of the Alliance, SSP Alliance, people, before there was an SSP Alliance – they were just people that were acting on their own volition or in small groups – began tagging people

that were going off-world into the slave trade.

And we've had some of these non-terrestrial groups that we work with, go and retrieve them and take them for healing.

So after all of this comes . . . all of the AI is gone, we've had Disclosure, people have had a chance to acclimate to Disclosure a little bit, a lot of these people that were in these different types of slave trades that have been rescued and are now in another star system going through healing, will be allowed to rejoin us.

And I know that's something . . . You know, I talk about this topic, and it is entertainment for a lot of people, but there are people that watch this show that have had loved ones disappear. And I hear from them.

So this topic is very real, and it is the most serious topic in Disclosure.

David: It's possible that maybe some of the people that are watching this show, if they lost a loved one, not everybody is necessarily going to end up in something bad.

Corey: Right. And these slaves are not always treated that horribly by different species. Some of these species respect what humans can do. And when it comes to engineering, manufacturing . . . our abilities, our innate abilities . . . And some of these groups that take humans they take them and . . . they take them off-planet and treat them very well.

Think about shows where you've . . . you hear of people having a maid that lives with them or that . . . So it's not all total doom and gloom. It's happening against their will, which is bad enough, but not everybody is getting eaten or being part of a sex trade.

David: Sure.

Corey: They really look for the most intelligent and gifted people on the planet, and they will either take them or one of their family members who have the same traits if they are too public.

David: All right. Good.

Now what we're going to have is our last video clip from the interview series, and this is **Tompkins** talking about a very interesting subject. Let's take a look.

* * * * *

MIND CONTROL

Tompkins: I was in a meeting on the subject with some other people, and this one young lady said, "I've got one."

And, "You've got what?"

[Whispering] "I've got one."

"Really?"

"I have."

"I've got a picture of it."

"UFO?"

"Yeah. A real picture of it."

"How'd you get that?"

"Well, we were having a party Friday night in Oceanside, and Saturday morning we went – all eight of us – we went to that cul-de-sac off of Lake Boulevard" - it's right over at Carlsbad. Now Carlsbad is next to Oceanside, okay? So they're standing on the border between the two – to show the other three couples their new condo that's being built just across the area.

So everybody goes out there, and they're standing around this fence because it dropped off quite a bit and then came back up.



So they took the picture, one picture of this whole valley thing – not a picture like that [pointing up like to the sky], but just straight out.

And they developed the pictures, all the party pictures the night before, and then this.

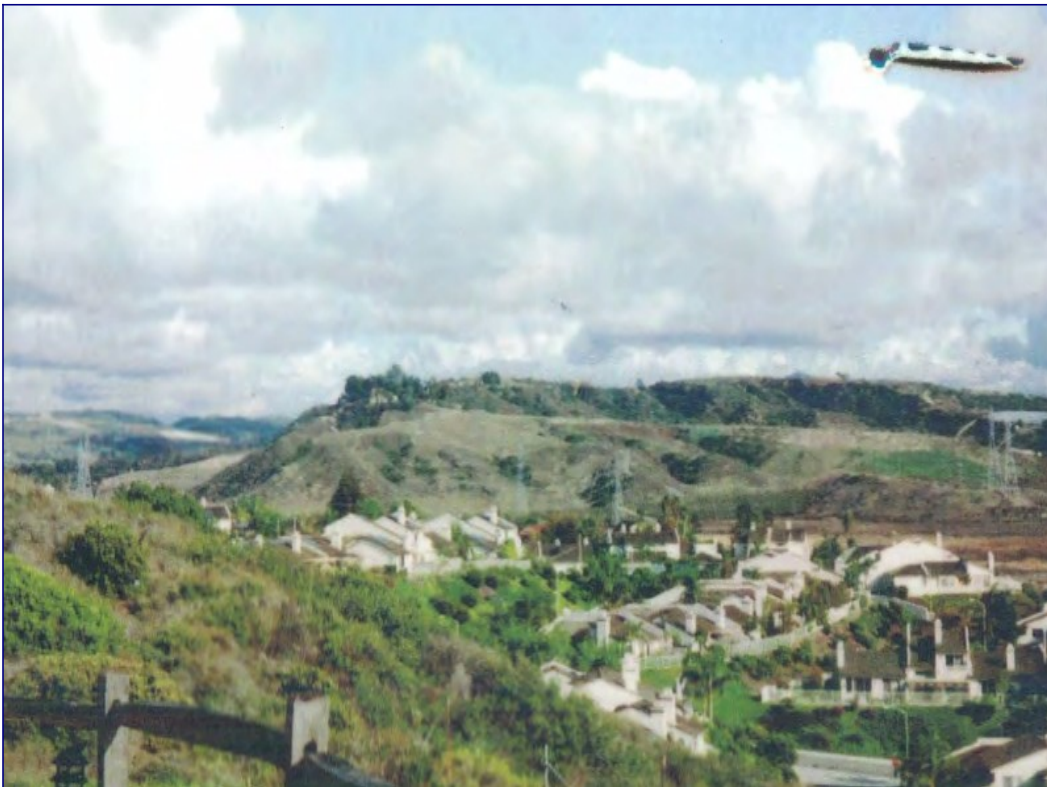

You'll notice it's serrated on the sides and it's serrated on the top.

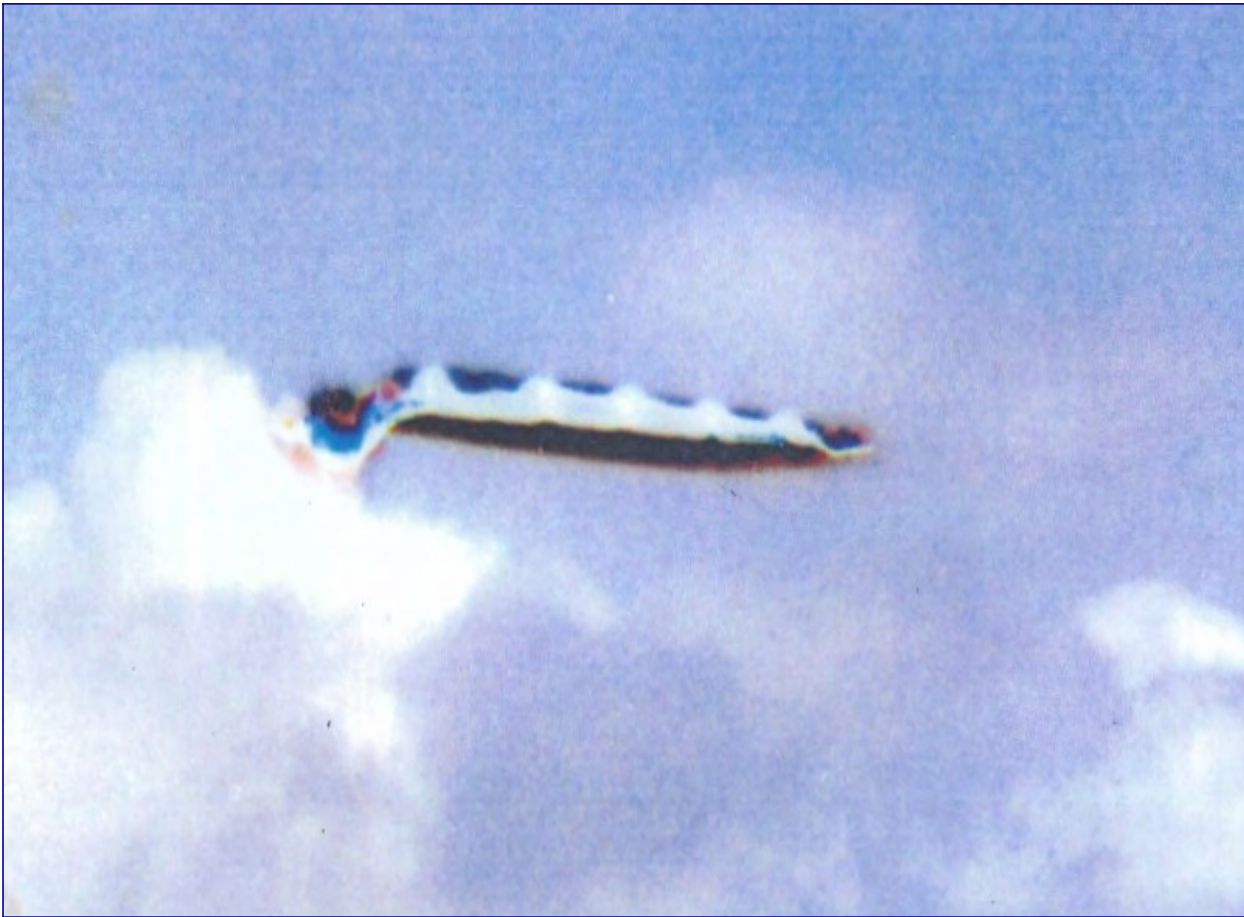

Look what's coming out of the back of it in color – five separate gases coming out of this Reptilian tanker, dropping five gases at 300 feet.

You're smoking their gas today, because they drop this gas only on technically advancing communities on the planet, okay, every four to six weeks. So you could be getting it today.

Not one – one, two, three, four, five, six. **THEY DIDN'T SEE IT**, because everybody's minds are controlled to not see it just like a stealth system.

So the commander of this squadron made sure that that stealth was turned on. He forgot to turn on the stealth that prevents a camera from photographing it. Okay?



So the reason you don't see these – they're flying all over us. There's hundreds of them. They're thousands of them every single day on your planet. They're dropping the gas.

So your mind is being controlled, and you don't function normally or how you should function.

And so, again, we are being mind-controlled not for the last couple of weeks but for thousands of years. And back to the Romans again, their minds were controlled.

And it's hard for us to accept that somebody's controlling MY MIND, and particularly – now this is extremely important – particularly because the brilliant PhDs in ALL technical fields, these people are most important for everything that we need in science, but their minds have been controlled.

So they are . . . they won't listen to what some of the rest of us are talking about because they “know everything”, but what they've been taught in those books at the university is all lies. Every technical field, it's all lies. It's incorrect.

And it's preventing people that put in the eight years, or whatever, knowing everything now, to accept this subject.



That's the reason Congress didn't accept it when the MUFON went back to Congress - the Democrats and the Republicans, neither one of them. Well, their heads were all nodding up and down, “Yeah, yeah, yeah.”

Ten minutes later it was removed, because they were already programmed. Their minds were programmed not to accept that.

I know this sounds insane, but this is fact. This is what it is.

* * * * *

David: All right. Well, I don't know about you, but that's pretty shocking stuff to me as a UFO investigator. I wouldn't have believed any of this maybe even as recently as a couple of years ago.

So, **Corey**, what do you think about this? What's your initial thoughts after seeing this clip?

Corey: Very interesting! What I have found out more recently is that they do drop gas – 'they' being the Draco. They do drop gas on technologically-evolving areas, but they also monitor each city, county, whatever, and if a certain amount of people are starting to wake up, they will go and drop mind-control gas on them.

It's more of a throwing bleach on a situation.

David: They would increase the gas if more people start to wake up in a given area?

Corey: Yes, they have . . . Not only do they use gas, but for the most part they use a technology that sends . . . that puts out a field that controls our minds.

You've seen people be hypnotized, and they'll say that . . . they'll be told that, "Okay, your wife is invisible. You can no longer see her."

And then your wife will walk between you and another thing, and you don't see the wife. You see through the wife, and you see what's behind it.

David: Right.

Corey: Well, the mind control works a lot like that as well. There are different layers of the mind control.

There's different layers of how the mind works, and they have to have a solution for each layer technologically and chemically.

David: This helps me start to put together other pieces I've been gathering for a long time. And the mind control stuff was always kind of sounding a little dubious to me, but I did have an insider, and he explained to me that there is an AI computer system that's monitoring everyone on Earth's thoughts, and that if you start to awaken to the things that this computer is programmed for you not to think about, that it will create things like nervousness, extreme exhaustion, tiredness, anything that it can do to try to divert your mind off of the topic.

Are you aware of anything AI-related like that?

Corey: Not specifically, but it makes total sense. If the Draco or AI prophets, if they report up to artificial intelligence, and all the information I've given on artificial intelligence about how it's controlling the planet, that's not a huge leap at all.

David: We're looking at a ship in this photograph that **William** holds up, and there seems to be other ships like that in the sky. First of all, he's mentioning a cloaking technique and it's not really clear if the technique is simply something that . . . we can't see it because we're mind-controlled not to see the ship, or is it that it actually bends light around the object? I wasn't really clear.

Corey: Both.

David: You think it's both.

Corey: Both. It is both. Yes, there's the component that I talked about – the hypnotism reference I gave . . .

David: Right.

Corey: . . . to where they put out a field to where they don't want you to see certain things, you just don't see them. You could have your dog next to you going [looking up at the sky], “What the heck is that?” And you don't see it.

It's set to the waves of how our mind works, you know, the alpha, delta, theta, theta waves.

So they're manipulating you on THAT level, and I say 'you', I mean us, because usually when you hear 'humans are mind-controlled’, just like he said, people sit back, “My mind's not being controlled. That must be OTHER people. I'm too far advanced, you know. I have special beings that I talk to. It's just impossible.”

But the fact is, all of us – you, me, people at home – we're all mind-controlled to a certain degree.

David: So when he was showing us this image of what he called a Reptilian ship, it has an interesting appearance, and I'm curious if you have seen any craft like that that were attributed to Reptilians?

Corey: Very similar.

David: Really?

Corey: Except they looked as if they were tankers that held a lot more volume of whatever they were transporting. And the experience I had was, I was seeing footage of these things bringing in water from lakes and oceans.

David: Hm. And because of this mind-control and cloaking, they could be doing this and you wouldn't even know that it was happening?

Corey: It could be happening right above you right now and there's no way you would know. They could be taking water out of your local reservoir.

David: Well, let's just kind of get through the fluff and get to the meat of this, which is, what's the purpose for us being mind-controlled? What's the big deal? What are they trying to stop?

Corey: Well, they're trying to stop us from advancing technologically so that we are an interstellar race.

David: Interesting.

Corey: And they're trying to keep us under control on this somewhat slave planet that they are wardens of. So there are a lot of reasons why they do mind-control.

Any of these sociopathic groups, human or non-, that are in a place of power, they want to keep that power. And if you have no moral compunctions about doing slavery, or any number of other things, controlling the minds of the people on a planet you control is going to be just . . . it's going to make sense to you.

David: Well, for those who have watched “Wisdom Teachings” or read my books, or are just familiar with my work in general, then they will know that I've done a lot of scientific validation showing, for example, in the last 5,000 years, our DNA has evolved by 7% across its entire structure.

That's a hard, solid scientific data point proving that we are going through some kind of Ascension or mass evolution.

Corey: Right. And that's one of the other things that I didn't mention that they're trying to stop . . .

David: Okay.

Corey: . . . is: they're trying to not necessarily prevent us from genetically and spiritually evolving, but control HOW we evolve. They're not completely stopping it, but they're controlling it.

David: So this is a spiritual war . . .

Corey: It is.

David: . . . in some sense.

Corey: Yeah! Absolutely.

David: Now, when I spoke to **Tompkins** in personal phone calls, he mentioned that the people in our military-industrial complex who are against the Reptilians are very concerned about shooting down these tankers.

And what he told me was, they've determined that although they have the technology to shoot the tankers down, they can't kind of gradually turn off the switch.

They're worried that when they shoot them down [finger pop], all of this technology turns off all at once. And he said that could be very bad for us.

Corey: Very bad.

David: Now, what's your take on that? What's your background on that?

Corey: I've touched on this on other episodes that, yeah, that's absolutely true. They're worried about when the AI is removed [fingers pop] real quickly, we may expect it to occur in a solar event that will remove the AI.

That will also remove these certain entities that attach to us and control us. They use entities for mind control as well.

David: What is that going to look like? What happens to the average person who's been under this mind control if it was suddenly removed?

Corey: Well, if you've ever seen a person that was addicted to heroin and then they stopped cold turkey, it's going to be very similar.

David: Really?

Corey: Yeah. They've had a certain state for so long that the shock . . . it would be sensory overload.

He said that we don't operate normally as human beings. That's true. We have other senses that are being blocked right now. It would be very similar to a blind or deaf person that all of a sudden – they've been that way all of their lives – and then all of a sudden they're gifted vision or the ability to hear. They're going to get sensory overload. They're going to have to acclimate.

David: Well, one of the things I remember reading, and this goes back to Val Valerian and his infamous Matrix Series of books in the late 1990s. He pointed out that the cell phone frequency that has been chosen to be used by the government happens to also be the same frequency that the human skull resonates at if you ring it like it was a bell.

Corey: Right. Cell towers, they're relaying data from your phone call, but they're also . . . that technology is . . . they're piggyback waves that are in there that are mind control. And this is part of this huge grid that goes across the planet that they use.

David: Do you think that somebody who lives in an urban area as opposed to a rural area, just by the number of Wi-Fi transmitters that are going to be around them, are going to be a lot more affected by all this stuff?

Corey: Absolutely. And you can see that in the behavior of people. You can see people act like idiots in the city because they're just piled up on each other, but there is more to it than that. They have all this technology around them to where they are getting hit with all these waves.

If you're out in a rural area, it's going to be a lot less exposure.

David: Now, one of the most audacious things is where **Tompkins** very confidently disses every type of science we have. And I forget his exact wording, but he called it “garbage” or something like that.

Corey: It's lies, yeah.

David: It's a very hard thing for people to – people who are not familiar with what we're talking about – to accept him making such a bold statement as that.

What do you feel is the reason behind that statement? How could that statement possibly be true?

I mean, it seems like with science we've figured out a lot of things. We've nailed a lot of things down. We've got some pretty good gadgets. We can travel.

Why do you think he would have said that?

Corey: Well, because every science you can think of, even archaeology, physics, medicine . . . all of these people are . . . it's like the Dark Ages. The information is basically the Dark Ages. And we'll look back at this time as being Dark Ages.

They're using antiquated information, and they have been basically brainwashed and taught through their schooling process that, you know, "This is the truth; this is the way it is," and not to think outside that box.

If you notice, people in these fields, if they try thinking outside of the box, they're labeled 'a conspiracy person' or 'a fringe person' and they don't get the respect they deserve.

David: Sure. We have to be dealing with a technology that is a lot more advanced than just what we would think of as a breathable gas, though.

If we're talking about a technology that could actually steer us away from certain scientific discoveries. This is obviously a highly advanced technology, I would think.

Corey: Oh, absolutely. Yeah, the whole planet is bathed in this field, this mind-controlled field. They use gas just for kind of a localized situation. A little red light goes off on their AI monitoring, then they'll send a small fleet over to gas the people, and then the little light will go off.

David: Most of the scholars that talk about mind control pretty much stick to ELF waves or extremely low-frequency waves. And there is research that has pointed towards the fact that if you beam a very low frequency, maybe 5 hertz or something, into a crowd, that you could induce mass hysteria. You could get the crowd to become very agitated. But we're talking about pretty grotesque, blunt movements of peoples' consciousness.

Corey: That's very low tech . . .

David: Yeah.

Corey: . . . what you're talking about compared to what these non-terrestrials have that they're using on us.

David: Do we have any way of understanding how such significant manipulation of our thought patterns is accomplished – how it is actually done?

Corey: We're going to have a problem understanding it, because we're in the paradigm of understanding and believing all of these scientific lies.

David: Right.

Corey: The people in these programs that were investigating it, they had the benefit of having the true sciences. They operate in a way that we just wouldn't understand, or very few of us would.

David: So once this mind control goes down – let's say that it does go down – once we go through this sort of acclimation process, what does it look like on the other side?

Corey: Well, yeah, once we finally acclimate to our new abilities, which are actually old, old, ancient abilities that have been repressed in us, then we're going to have to learn how to use them responsibly. We're going to have to learn how to interact with each other in a whole new way.

We've been so programmed to be at odds with anyone whose skin is slightly different, or you worship a slightly different named God. We're programmed to inter-fight.

We're not going to be able to overcome that like that [snap of the fingers]. It's going to be a process.

So we're going to have a process ahead of us once Disclosure happens.

David: All right. Well, that's all the time we have for in this episode – very fascinating stuff. This is “[Cosmic Disclosure](#)”. I'm your host, [David Wilcock](#), and I thank you for watching.

Cosmic Disclosure: Viewer Questions 10: Ascension Concerns and End Times Madness

Season 8, Episode 6

David Wilcock: All right, welcome back to “[Cosmic Disclosure](#)”. I'm your host, **David Wilcock**, and here with your questions is the one and only **Corey Goode**.

Corey, welcome back to the show.

Corey Goode: Thank you.

David: Okay.

“I love your questions and answer episodes. I am confused about one thing, though. I have heard **Corey** on other programs state that the Chinese will be, for lack of a better word, in charge of a new currency for 100 years.

“If we are to have this cosmic event between 2017 and 2023, which I thought was our Ascension, why are we worried about anything after that? Won't Mother Earth shed these negative beings as she ascends?”

Corey: There are various groups that have different agendas and plans, and they're prosecuting those plans, you know, the way they would as if they were going to win.

If these energetic things occur, or some of these other things occur that I've been told recently about non-terrestrials making themselves known to people in small groups, then I don't see their agenda being able to come to fruition.

David: So the Chinese, the basis of their idea of wanting a 100-year financial system comes from what?

Corey: It comes from the negotiations that have occurred between the Alliance and the Cabal. They said the West had its 100 years. They want their 100 years to run the financial system.

David: So you're equating the Chinese with the Alliance in some way?

Corey: Yes. Well, the Chinese are a large part of the Alliance, and they're the ones that have been predetermined to take over that financial system, or lead it.

David: So let's just be clear on what is the Chinese plan? Are they wanting to do exactly what the Federal Reserve did? Are they wanting to enslave us?

Corey: It would be a different type of Babylonian slave system, money magic system, of course, as long as there is a financial system, but it's supposed to be a fairer system that is fairer globally, and is based on gross domestic product and other things, other than how much wealth one country has accumulated and using that wealth against other countries.

David: Do the Chinese feel that they have been unfairly pigeonholed into a more poor level? And is that part of what they want to do, is to even the playing field?

Corey: That's the entire reason that the Alliance formed. It was to fight against this Western Cabal that had basically taken over the financial system and most of the infrastructure of this planet.

David: So do you think that the Chinese would preferentially boost the economies of countries like Southeast Asia, Africa, places that have been disadvantaged?

Corey: Not only that, but they're heavily investing in these areas, like South America, parts of Africa. They're buying up land and property as fast as they can.

David: Obviously, the Chinese should be vetted out on the idea that there's going to be a solar flash, but do you feel that if they do know about it, do you think they just don't see the significance of it? They're just going to plan around it not happening?

Corey: Everyone knows about it, but as I've stated before, depending on the group, they have different ideas about what is going to occur when the solar flash happens.

Many think that it's just going to cause a lot of technological communication disruptions.

Some think that it's going to destroy anything that works on an integrated processor.

David: Hm.

Corey: And others think that it's going to be some sort of an Ascension event, or a mass death event, a kill shot event.

David: Right.

Corey: So there's no real agreement on what is going to occur when the Sun does have this “Sneeze”, as they're calling it.

David: Since we're on the topic, what is the most current speculation about when this would be taking place that you've heard?

Corey: Now, the actual solar event, I'm not sure, but the same dates apply. You know, was it 2018 to 2023, I believe was the window?

David: Uh-huh.

Corey: They extended the window a little bit on that, but they still expect these massive events to occur. And it sounds like it's more than one event, not just a solar event that's to occur in this window.

David: Well, certainly we know in “The Law of One” that it's portrayed as being very positive, and the beings that have been in contact with you are portraying this as a very positive thing, correct?

Corey: Correct.

David: That it will be some sort of Ascension-type of thing that takes place.

Corey: That it will . . . Not necessarily the Ascension that everyone has in their different belief systems, but an Ascension, . . .

David: Right.

Corey: . . . which is basically going to kick off what occurred with Mica's people, which is a consciousness renaissance.

And this Ascension is basically going to be a consciousness thing more than it is a physical, you know, “twinkling of an eye” thing, from what I'm told.

David: Right. Well, that's very good. Next question:

“This latest '[Cosmic Disclosure](#)' episode really helped me understand better the nature of time, timelines and time travel. I would love to hear much more on these topics.

“I found it particularly fascinating that **Corey** mentioned how the Cabal's artificial intelligence future prediction technology seems to be much more unreliable lately, possibly due to more and more good folks focusing on a more positive and productive future for us all.

“Or perhaps it is due to them messing with the timelines so much. Or maybe the nature of time is changing somehow with new energy shifts.

“In any case, this seems to be a very good sign, and an indicator that we are all making headway into a more beneficial timeline. What are your thoughts?”

Corey: There are definitely signs that we're headed into a more positive timeline, but apparently, it could be better.

The Anshar have shown visible anxiety about maintaining their timeline. So it's not all roses, I guess you could say.

There is a lot of work that needs to be done. And most of it is work that we need to do within ourselves, and also spreading the word about what is going on energetically, the changes, and you know, try to get as many people to wake up as possible.

David: So just to be clear on the nature of the question, are you saying that whatever artificial intelligence was being used to probability-model the future, that it's becoming increasingly errant in its conclusions?

Corey: Yes. It has to do with what's going on with this strange Mandela Effect, you know, the nature of time changing.

David: Hm.

Corey: And it also has to do directly with these energetic changes that are occurring.

David: One of the levels of this question was, is it being . . . is time changing because more and more good people are focusing on a positive timeline? What could you say about that?

Corey: Yes. The co-creative consciousness of people that are more, I guess, positive and trying to intentionally create a positive future, are having a direct effect on what's occurring on our reality.

That's why more and more people are needed to become more focused on meditating and group meditation, looking for a positive outcome for our reality.

David: Okay. Next question. Here we go:

“I think I'm confused on the whole, being in regards to Service-to-Others. I notice I'm attracted to depressed and broken women. I always try to help them see the light, but they just never seem to be happy.

“I'm currently in a relationship and she's very negative and drags my energy down. I try to make her happy, but it only lasts for a few minutes, and then she's right back to complaining about something else.

“Is this something I should continue to do?”

And I guess he means, should I continue to be involved with her?

“Am I not getting the proper point of how to be of Service-to-Others?”

Corey: Well, just because you're being Service-to-Others does not mean you have to be a doormat to anyone. A lot of people confuse that.

They think that you have to be, you know, just succumb to any attack and not fight back.

When it comes to . . . Ka'Are, one of the big things that she had told me to work on – there were two things before I could progress spiritually any further, and it was outstanding issues on my marriage that we hadn't dealt with, and the other was to reconcile with my father, who I hadn't spoken to in six years.

David: Wow!

Corey: And both things occurred in the last several months. You know, a catalyst came in, a point to where, you know, Stacy and I were going to separate. There was a catalyst, you know?

And it was a situation that . . . it brought on healing, and we were able to mend things, and things are better now than they've ever been.

David: Well, I'm glad to hear that.

Corey: And the same thing with my father. I was able to, just after Father's Day, have a reconciliation with my father.

So that was a major release of energy on [for] me. And so these different, I guess, relationships that you have can act as a parachute and hold you back. But, you know, I think that we do need to give the other people in the relationship an opportunity to grow.

And a lot of times, us leaving is that catalyst, but I am not qualified to give relationship advice by any means.

David: What do you think about the principle of people being stuck in some kind of depression? And have you explored the possibility that there is a connection to this solar event and the changes that the Spheres are here apparently to buffer?

Corey: Yes, so most recently, I was told by Tier-Eir to expect the End Time Madness type of behavior we're seeing in people to dramatically increase.

You know, everyone, all of our different personality distortions, are being focused and exposed. You know, just the different things that we haven't dealt with are being exposed in our lives, and we're being forced to deal with them.

But we're also noticing, because of the increase in energetic waves, that people are being pulled in the polarity that they lean most towards.

Negative people are becoming much more negative, and they're coming together. Positive people are doing the same.

And, of course, we talk about people that happen to, unfortunately, have mental disorders. They're having a lot of problems right now. And that's going to only increase.

David: There's some interesting material in "The Law of One" regarding the path of Jesus when he goes into martyrdom and basically offers up his life on the cross.

And they do actually say that if he had chosen to live, that he could have been here longer and done more service. And so they explain that there might be a Judeo-Christian bias for people towards self-martyrdom.

Do you think that there are people like our questioner who feel maybe that self-martyrdom is this positive thing? That if they are constantly on the cross with someone and bearing that, that that's a good thing for them to be doing?

Corey: Yeah, I mean, a lot of people will think that we're burning off karma, and sometimes we are. But a lot of times, you know, we're creating our own problems.

By not trying to actively grow, you're going to become stagnant and locked into situations like that.

You have your own growth that you need to focus on. And if we're going to change the world one person at a time, we have to focus and love ourselves just as much as we do the people that we're martyring ourselves for.

David: So since you've had in-person interactions with several different types of benevolent off-planet beings, or Inner Earth beings, if you were in a situation where you had to sever a relationship of whatever kind, friendship or whatever, that was maladaptive, what kind of advice do you think they would give you?

What would they say? If you can remember something, what would they say?

Corey: Absolutely. With my marriage, I was bringing THAT up to them, and they would not give me advice. Everything that ended up happening, happened exactly as it was supposed to.

The catalysts that created all the changes would not have occurred if they had intervened.

David: Ah.

Corey: They told me also, a lot of the times, what occurs in our life, is something that is set before us by our higher selves.

And our higher selves are trying to guide us and teach us, and that they're not going to interfere with that process.

David: Very interesting. So we have another question now. Apparently, we've had some comments of people thinking that it is derogatory for you to refer to one of these beings as a “Golden Triangle Head being,” emphasizing its physical attributes instead of, why doesn't **Corey** just say what his or her name is? So what would be your answer to that?

Corey: That's literally what they're being called in the briefings and documentation, is the “Golden Triangle Head beings.”

David: Ha, ha. Okay.

Corey: The name that we have been given for them is a long, weird sound. It's not anything I could reproduce with the vocal chords I have.

So that's why they are not called by the name that they have given.

David: So they would have some alternate way of verbal speaking that is not something we could easily produce, if at all?

Corey: Right. Yeah, we couldn't make the noise. I mean, you could create it with a computer, most likely, but . . .

David: What would be the pitch range of the noise?

Corey: Real high pitch. It's not really whale-like, but it's a weird thing – similar.

David: All right. Next question:

“I'm still confused about the 20-and-Back program. If you are in space for 20 years, and then are inserted back 20 years ago after you have completed your mission, then you would be on Earth and in space at the same time during those 20 years.”

This is like the whole “Back to the Future” thing.

Corey: Yeah, but it's different timelines.

David: Right.

Corey: In one timeline, you're not on Earth, and you've been reported as a missing person.

On the other timeline, you're on Earth. So they're not exactly during the same time. They're different . . . almost like different reality, layered realities.

David: Hmm. Okay. I think that probably helps to answer the rest of the question. He says:

“Then 20 years after you were inserted back on Earth, you would still be in space finishing your mission, then inserted back on Earth 20 years earlier, and you'd be in an infinity loop, stuck forever. I'm just wondering what **Corey's** response is to this.

“Everything else seems to check out. I'm sure there's a good answer, but it has yet to be brought up.”

So I guess they're looking at the idea that if there were two mirrors facing each other, that you're going to see multiple levels of the mirror. And so, if you're on that timeline in space, and then you get brought back to Earth, then you go back to space again, back to Earth again – ping-pong, ping-pong.

Corey: People now have a pretty easy . . . well, not all, but a pretty easy time understanding space and the cosmos. Understanding time and how time blends with space, people don't really understand.

It's a hard concept for a lot of people to understand that these advanced non-terrestrials are more time travelers than they are space travelers, because of the technology they have.

David: Right.

Corey: They can travel into our past, into our future, into our present. They can jump all around.

David: Can you even travel in space at higher speeds without traveling in time?

Corey: No.

David: Or is it all one thing?

Corey: No. Any time you're . . . Even when you're walking across the room, you're traveling in time.

David: Right.

Corey: It's just as you increase the speed, . . . you know the rest.

David: So would you say, then, that these alternate timelines somehow merge in order to prevent the world from spiraling into some sort of paradox?

Corey: Yes. It would blow people's minds, the amount of merging and separating that occurs constantly, moment from moment, as we're progressing, you know, from our zero time reference.

Behind us and in front of us, there's all these changes occurring.

David: And it looks like there are two parts to this, so I'll hit you with one at a time instead of reading the whole thing at once.

“Number one: why do the Secret Space Program and the sophisticated alien races use human slaves? Hasn't artificial intelligence and robots become sophisticated enough to handle 'slave labor'?”

Corey: AI is definitely sophisticated enough, sophisticated enough to where it has become the enemy of most of the beings out there that are benevolent and malevolent.

Most of them say, they'll use a certain amount of AI that will go no further, that will not . . . that has a certain purpose.

But they monitor that very closely, because in just about every case, if you create AI and it gets exposed to this AI signal, then, it is then co-opted by that greater AI being that is out there in the cosmos.

So most of these beings stay very much away from AI type of robotics.

They do have androids that are sort of like the Greys, that are sort of a bio-android machine that they can program.

But for doing fine tasks and engineering, all of the different things that they like humans for, they prefer humans that have been raised on the Earth, have experience on the Earth in certain industries.

The clones do not work as well for them either. The clones are highly programmable, but they don't have the intuition and all the other attributes that a human that has grown up here has.

David: So do you think that there would be a high level of interest from the Secret Space Program in recruiting people who had grown up in a normal human life on Earth, and then bring them into this occult world?

Corey: Yes. Most of the recruiting occurs within the military. It's a very small percentage of civilian assets that are used. And most of them aren't on a 20-and-Back. Many of the eggheads or engineers would be there for 18 months, four years, eight years, and back.

The military mostly did the 20-and-Back.

David: Why would they be so prone to not want to use civilians?

Corey: They're not as easy to control.

David: Hm.

Corey: And for the most part, they try to keep as much of it compartmentalized in the military as possible. They have to use civilian engineers, civilian scientists, and they also use different people, like myself, that have been in programs to where they're groomed to work in the programs.

David: Why do you think they might allow any of these people to ever return to our world and not just keep them there indefinitely?

Corey: That was an agreement that was made with the non-human group that gave them a lot of this technology that they're using.

David: Hm. They weren't allowed to just take everybody forever.

Corey: Right. And they have to . . . That's why they have to blank-slate people when they put them back.

There are a lot of rules that they're supposed to be following to use this 20-and-Back technology.

And this technology was basically handed over to them. They developed it out, of course. But it was basically handed over to them by a non-human race that was working closely with them, the Navy group, to form a navy that would help fight the Draco and other aggressors.

David: So do we know which group it was that gave them this technology?

Corey: It is believed that it was the Nordic race that was the group that was giving them the most technology.

David: Hm! Interesting.

Well, let's just talk about this Navy versus Air Force thing for a minute, because as we know, there wasn't even a CIA until after World War II. It started as OSS, Office of Strategic Services.

Corey: The same date that the Air Force started.

David: Right. So if fighting World War II, that there is a branch of the U.S. military that's doing air joint missions with the British against Hitler in Europe, but then the Navy is actually at sea in their own enclosed capsules, and that's more of just a straight-ahead American component, without the British being involved, how do you think that might have affected what we now see as Air Force versus Navy?

Corey: Well, the Navy was, of course, equipped already from the beginning, infrastructure-wise, knowledge-wise, to build deep space vessels and maintain them.

David: Yeah.

Corey: You know, they were sending people out six months or a year at a time on ships. Later on, they were sending them for long periods of time under the water in submarines.

So with slight modifications, they could take that and make it more of a deep space type of fleet.

David: Uh-huh.

Corey: Now, the Air Force was working close with the DIA, and they were working close also with the military-industrial-complex, more of the face that we see, not the hidden part.

They were producing the technologies for SDI as well. These technologies were creating space stations in near-Earth orbit, within 500 miles, triangles to service them.

And they have a small footprint on the Moon and Mars – a very small footprint.

So that is the program that they want to disclose to the population first.

David: So how do you think the origin of the Air Force in World War II, with the air support that was going on for World War II against Hitler, and that British collusion, might have affected their political structure now?

Corey: Well, I believe that once they saw that we were going to be able to reverse ET technology and use it out in our own solar system, they began to work closely with civilian intelligence, trying to get that centralized.

Of course, it was during that time that they also made the existence of non-terrestrials and their technologies the most secret thing on the planet.

David: I guess I'm just going to get really aggressive and ask this directly. Do you think that as a result of what became the Air Force having more involvement with the British, that there might also be more of a Cabal component to the Air Force than there is to the Navy side?

Corey: Yeah, there absolutely is. They are more tied to civilian intelligence, and the civilian intelligence . . . The entire infrastructure has been taken over by the Cabal.

David: All right. Then he has a Number Two:

“Do we face an immediate threat to our society from upcoming AI and robots taking over most of our jobs?”

Corey: It just depends on, I guess, the future we choose. If we keep heading into a transhumanist type of way, which a lot of the intellects are heading – you know, they want us to get to a point where we can upload our consciousness to a computer, or turn ourselves into a mixture of man and machine – that would not be an optimal temporal reality.

David: For sure. But it sounds like the threat is much deeper than them just taking our jobs. You're talking about a total domination.

Corey: Usually what occurs on the planets is that the native beings will create this technology. This technology gets co-opted by this AI signal, or they develop technology with, alongside, the AI signal after they've been Trojan-horsed, kind of like a Roswell situation.

They build out this technology, and then the technology turns on them, very much like “Battlestar Galactica”.

David: And just to clarify in case somebody didn't know what you were talking about, what is the AI signal?

Corey: The AI signal is a signal that they don't even know how old it is. It's just billions or trillions of years old.

This signal somehow, they say, came from another reality. And the signal is being broadcast all throughout the cosmos, and the AI has actually taken over entire galaxies in the cosmos. It's like a virus.

David: So what does the signal do?

Corey: The signal will interact with technology. That's what it prefers to do. But it will also get into a planet's electromagnetic field and stay dormant there for thousands of years until technology comes by and it can piggyback on it.

It can also lodge within a person's bio-neuro field, and people can carry the AI around and distribute them to various devices.

David: So can it introduce ideas and thoughts into someone's mind?

Corey: Yes.

David: And those thoughts would be towards what?

Corey: Pro-AI type thoughts, or leading them to do things that will benefit the AI, you know, like a parasite.

David: So to develop the technology that it would need for its own . . .

Corey: Or get it to the technology that it needs to leapfrog out of you to get into to do whatever its mission is.

David: Okay. Well, thank you, **Corey**, for answering everyone's questions. And I want to thank you for sending them in. We do read what you're saying, and we listen, and we respond.

This is "[Cosmic Disclosure](#)". I'm your host, [David Wilcock](#), here with our special guest, **Corey Goode**. And thank you for watching.

Cosmic Disclosure: The Ascension of Earth

Season 8, Episode 7

[David Wilcock](#): All right, welcome back to "[Cosmic Disclosure](#)". I'm your host, [David Wilcock](#). I'm here with **Corey Goode**.

And in this episode, we're getting into a long-awaited update about several key issues that are happening right now.

So, **Corey**, welcome to the show.

Corey Goode: Thank you.

David: So, **Corey**, we've described how the Anshar have been worried about our future. And a lot of this concern seems to have coordinated with the timing of this eclipse.

What were you told about the eclipse exactly from the Anshar and how it relates to what's going on now?

Corey: The eclipse was an energetic alignment that was going to enhance our co-creative consciousness' ability to make thoughts into real things, supposedly.

What she said was that a . . . and this was in concurrence with what Tier-Eir had stated about doing mass meditations. We had gotten together with a few other people and put together a mass meditation on the day of the eclipse, and the Anshar were very happy about that.

And they stated that they were going to participate in it as well, and that a lot of the contact that people were going to receive was going to be initiated then. But it was very interesting.

During the eclipse, I was standing out looking through a filter at the eclipse. And everyone was meditating and putting out good intent.

And I was in the middle of doing that when, through the filter, I saw a little flash to the bottom left of the Sun.

And I was just about to say something about it when the lady next to me came up excited and showed me her phone.

“Look what I got! Look what I got!”

And just in the exact spot I saw the flash was a triangular craft. And we caught it . . . We got a photo of it.

David: Very cool.

Corey: And it was very interesting that that occurred during the time when I was putting out intent for humanity to receive assistance.

David: Now you brushed on something very briefly that I think we need to cover more, and that is this concept of contact.

What was the nature of this contact you were informed about by the Anshar that would be happening, or that they were trying to make happen?

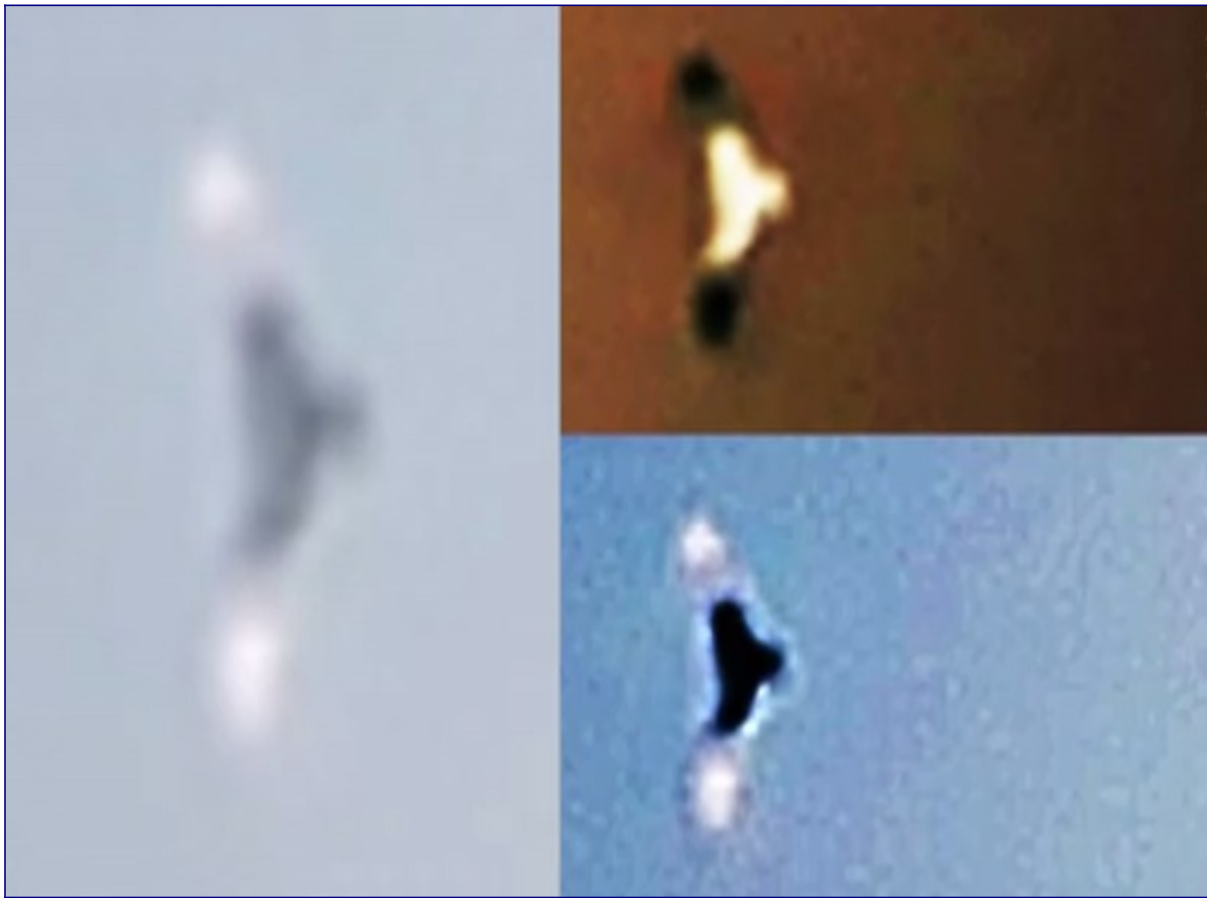

Corey: Well, they stated that contact in the beginning would start out with people having dreams.

David: What contact would take place?

Corey: Contact between the Anshar and people on the planet.

David: Okay.

Corey: They would begin to have dreams that would slowly acclimate them to finally having an in-person meeting with the Anshar.

So I was expecting things like that to occur during the eclipse.

What I didn't realize is that a lot of the people that were participating were getting these downloads, just information rushing down into their consciousness, giving them ideas about how to use their talents, about how to solve issues in their lives.

And I was expecting something a little bit more dramatic.

Soon after I got home from this event, I did have a meeting with Ka'Aree, where I asked her more about this.

David: So these contacts start out, as you said, with dreams and possibly telepathic things. Where does it go from there?

Corey: Well, it actually starts a little bit differently.

After I got home, I was exhausted . . .

David: Home from where?

Corey: . . . from the Eclipse of Disclosure at Mt. Shasta.

David: Okay.

Corey: I'm laying in bed, and the next thing I know, I'm in that exact same greeting area that . . . the first time I had met the Anshar. And I'm laying on my back.

But this time, there's a thick bed mat that – it was pretty interesting; I don't want to go into detail on that – and then a round head roll that was behind my neck.

And immediately, I looked up, and I saw Ka'Areë and two others standing. And she just briskly asked me to get up, and we walked back to that original meeting room where she had offered me the Elixir of Isis.



She was kind of frazzled or in a hurry.

She brought me back to discuss the eclipse and the mass meditation. And she was stating that it was a very big success, that . . .

David: Oh, great!

Corey: Yes, that a lot of people that partook in it received massive downloads, only a little bit that they were conscious of, that was going to help them prepare themselves for contact.

And I told her at that point that I appreciated seeing the UFO in the sky, but I was expecting something a little bit more dramatic to occur.

And she told me that I had jumped to a lot of conclusions, that there is a very specific way that the benevolent beings have to approach humanity.

And I thought it was interesting.

She said that they see us on a little bit more of a level than just our physical personal egos. They see us on a multidimensional kind of level.

And before they can come and introduce themselves to us, they first have to approach our higher selves.

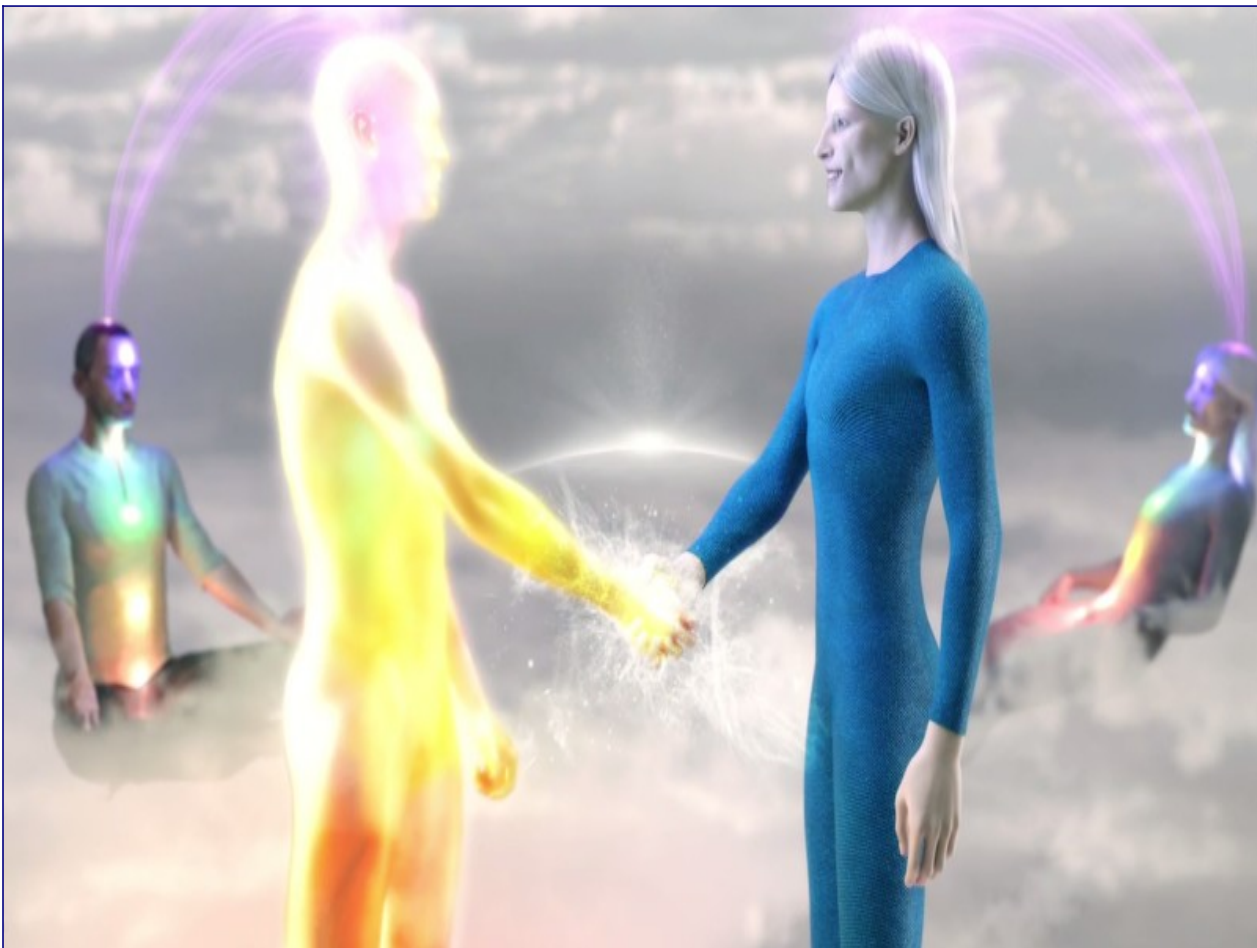

And our higher selves determines whether we get contact, what type of contact we will get, or what we need before contact – what we need information-wise to prepare ourselves.

So it's not the case that I thought that these beings just come to us because we have the right vibration or they think we're ready.

They come to us because our higher selves have approved it . . . have approved that contact.

David: Now, you said a while ago that, I believe, it was Tier-Eir had told you that as we get closer to the solar flash, people would start seeing ghosts of some form.

Corey: Yes, he said as the energies peak – reach their peak – that you will know this because all across the world, people will start describing stories of meeting family members that have died and having conversations with family members who have passed on.

David: So do you think that perhaps these Anshar visitations could also come in the form of that, as they say contact is going to unfold over time?

Corey: What it sounded like is that they approach our higher self. Our higher self and them come to an agreement about what type of contact our egos will receive.



If our egos are not ready for one-on-one contact, our higher self will converse with the being – the Anshar, in this case – and say, “This is what they need to be prepped, . . . to prep for that type of communication.”

And they'll receive the information they need in the form of a download – an information download.

David: It's been pretty stunning to me to see how soon after the eclipse we've had massive hurricanes. Do you think that is related to this eclipse and what they told you was going on?

Corey: I was shown basically a vision of what is occurring. And the Blue Spheres are almost gone. They're almost completely translucent and gone.

And we're receiving higher and higher doses of this cosmic energy. Our planet and solar system are bathed in this energy right now.

The image I was shown was of the Earth spinning, rotating within that energy, and it was like a dynamo. And the energy was feeding into the Earth through the poles.

And in the vision, it was causing massive, high-energetic storms like what we're seeing and earthquakes.

David: So some people have tried to say that these are HAARPicanes, that they're not natural phenomena, that the Cabal is doing this to try to collapse the American economy. What are your thoughts on that?

Corey: These storms are not created by these technologies, but they are being steered. They have satellite systems that shoot, I think, what they call masers – microwave lasers, focused microwave beams – into the ocean, close to the storm to warm up the water. And that causes the storm to go towards the warmth, and they can lead the storms where they want, to a degree.

David: Do you think that the American economy can survive disasters of this scope?

Corey: It's going to affect the economies, but more so, it is a distraction. It's [a distraction] to all of these groups that are working on trying to set up arrests and courts to hear these cases. The military is heavily involved in this.

If you have all of these major events occurring – weather events – then the military has to be pulled over to assist.

David: Wow!

Corey: So it's – t part of it, at least – to be a misdirect.

David: Why do you think North Korea has been acting so crazy lately with this nuclear threat that they're making?

Corey: Well, North Korea is . . . I mean, it's fairly well known that the Cabal has a certain amount of control in that country, although it appears that we don't. So they are a perfect distraction tool.

Now, another theory that I've heard was that North Korea would become such a threat that we would have to use new exotic weapons platforms that we have never disclosed to the public. But the only way we could use them would be to disclose them to the public.

And that, to me, sounds like a perfect opportunity to disclose triangular craft that are used to go down and try to neutralize North Korea before they fire all of their ordinance into Seoul.

David: **Pete** Peterson has been saying a lot lately that what he kind of affectionately calls “quadcopters” - though these are full size and piloted – that the military is very close to unveiling these.

Corey: That's exactly the intel I'd been given. And if you remember on the show here, maybe six months ago, I was reporting that the Air Force Secret Space Program, they were going to begin to “accidentally” let us see a lot more of their triangular craft.

I reported that we would start seeing reports of triangular craft.

And indeed, recently over an Air Force base in Tampa, on two separate occasions, people have been taking photos of triangular craft. And I believe we have an image of that.

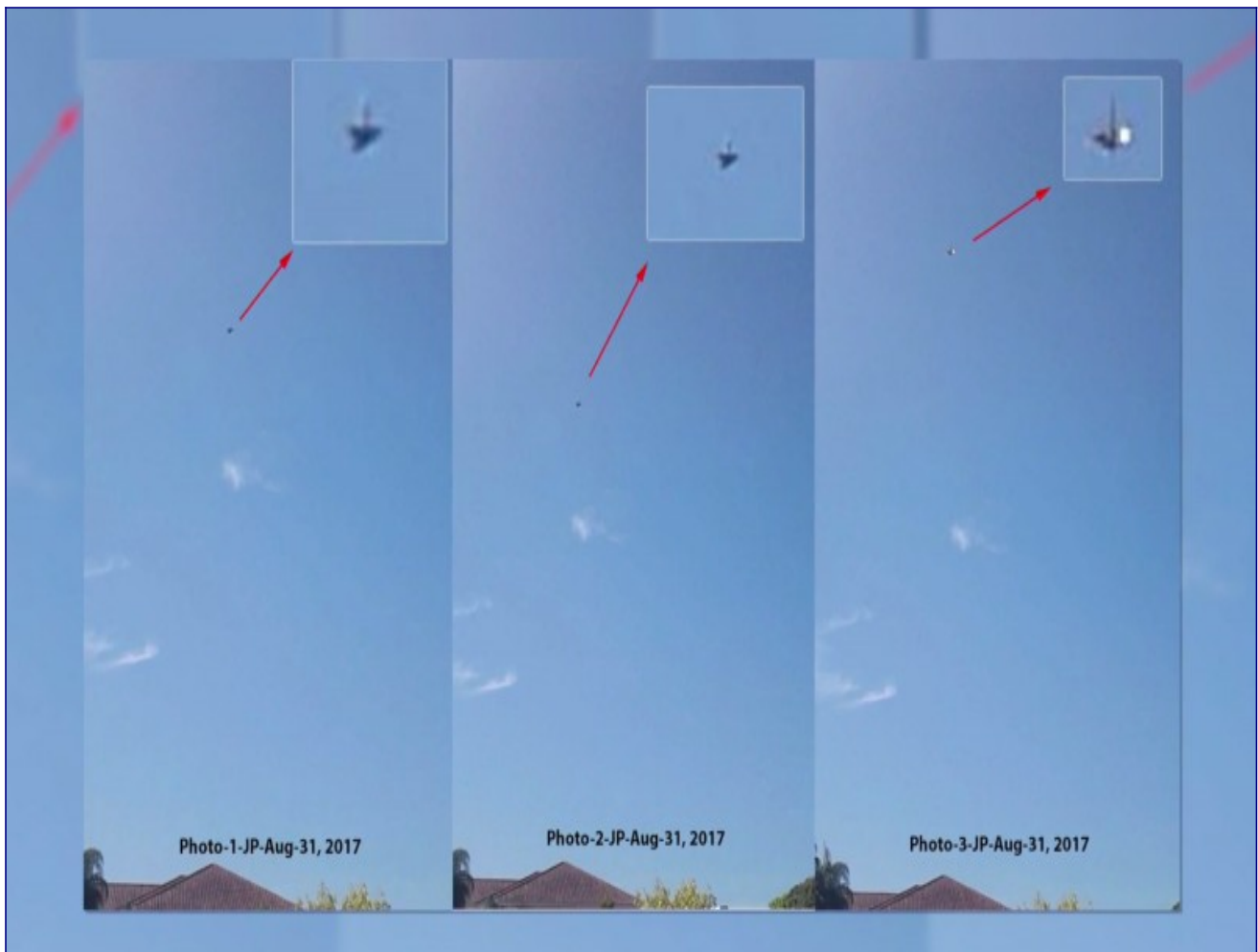

David: When you were meeting with Ka'Are, and she's telling you about . . . that contact is going to develop, did you get a sense . . . I know we're talking about higher-self handshakes and so forth. Did you get a sense that eventually people like those watching this show might actually have the type of in-person experience like you've been having with them?

Corey: Absolutely. The Anshar basically let me know that the visitations that I'm having, it'll become commonplace, and that I will, like I want to, slowly kind of drift off into the background because everyone else, or so many other people, are going to be having these one-on-one experiences.

David: Do you think there would be a way at some point to be able to validate who is actually having real experiences, as opposed to who's just trying to jump into the spotlight and gain some attention?

Corey: I think at that point it won't matter.

David: Why wouldn't it matter?

Corey: So many people will be having open contact that the attention-seekers that are lying, . . . it'll be pretty obvious who it is. And it just really will be of no consequence to everyone else who is receiving contact.

David: Do you think that if we have more catastrophes take place like these hurricanes, and everybody's having to go through that, that that in some way opens up more of the universal law for the Anshar to do these type of contacts?

Corey: I don't know about that, but when I spoke last to Tier-Eir, when he was showing me all of these things, I was a little perplexed about why these things were being allowed to occur.

And Tier-Eir stated that while these things are happening, it will be an opportunity for people to be Service-to-Others. And that's the only real response I got on that. The Anshar did not go that in depth.

David: Now you've had another meeting with Ka'Areë much more recently that really has some fascinating new plot twists in it that actually caught me off guard. When you first told me, I was quite surprised.

Corey: This was the same meeting.

David: Oh, it was?

Corey: Yes.

David: Okay.

Corey: Once again, I had noticed that she was acting abnormal. She was a little bit stressed, and, like, preoccupied.

So she was behaving abnormally from the way she normally behaves, you know, real calm, serene. She seemed preoccupied.

And I asked her if the timeline was continuing to diverge from the timeline that they were sent here to steward. And she said, "Yes, that is indeed the case."

And she said, "Things have developed quite far in the timeline" – divergence from their timeline.

David: And just to be clear, what you had said was that this negative timeline could involve a very dark future for humanity. Could you reiterate what that was?

Corey: Well, it was a very dark future for humanity, but the Anshar were concerned because if that timeline was diverged from, they would no longer exist.

David: If our positive timeline . . .

Corey: Right, was diverged from. Or, well, THE timeline that they were trying to manicure.

David: So she's concerned, indicating that she's worried whether that negative timeline might still take place.

Corey: Right. And I asked her, “Is this completely unheard of?”

And she said, “No.”



She said, “We have gone through this on several occasions during the changes of cycles,” that her people have had to take drastic measures during the cycles.

And I asked her what she was talking about, and she started walking me back to the area where I had first appeared, that radiated out into different hallways.

She took me out in there and immediately hung a right and went through another hallway. And we eventually ended up in an area that came out to where we could see where the giant city was that I described before.

And we exited in a different area. We popped up from a different perspective.

And as soon as we looked into this huge, huge cavern, it was immediately obvious that everything had changed. None of the buildings were there anymore.

The rock pillars that went up to the roof of the cavern that had all of these dwellings cut out in them, those were still there. There were no lights.



And there were little footprint areas where all of the buildings had been.

David: Really?

Corey: Yes. And then there was this weird, . . . this weird . . . It looked like time-space folding in on itself, kind of going into a cone.



And where the cone ended, it was, like, flailing around a little bit.

And I asked her what it was. And she stated that in times past, during the cycles, the Anshar have put their people in this time-anomaly bubble, and that this time-anomaly bubble is exactly the same as the anomaly-bubbles outside of Jupiter and Saturn where the Super Federation has these giant stations, where they meet.



David: Do you think that the Anshar dwellings are built to be modular, that it's like a little craft . . .

Corey: They are.

David: . . . they can move around?

Corey: Yes.

David: It is.

Corey: Yeah. And what had happened is all of them had levitated and gone into the event horizon of that anomaly to where they would be protected from everything that's occurring energetically.

David: Would that include that if the timeline shifted that they would still have a reality partition that they can live in?

Corey: Exactly.

David: Really?

Corey: They have their own little reality bubble.

David: Hm.

Corey: And in the conversation, she stated that . . . I learned a little bit more about the anomalies, how they work, which is very interesting.

We're supposedly inside this protective barrier here in the solar system. And she's saying that when we enter that anomaly, when we were going to those meetings, we were going to a time-space bubble that had been created that was outside of our reality, so to speak, and that there were entrances to it in, like, other galaxies. From other galaxies, beings were flying in to attend these meetings, but you have to go out the exact same way. You have to punch out the way you punched in.

David: Um-hmm.

Corey: They can't come in and then go out another exit and end up in our galaxy.

David: Hm.

Corey: The majority of her people – that entire city – are inside that anomaly right now.

David: Well, this raises an interesting question, just really briefly. And that is, if these people are sitting in these chairs, and they're telepathically communicating with us, apparently as, like guardian angels, and helping us meet the right people, and have telepathic nudges, and things like this, if they all took off, wouldn't that dramatically undercut our angelic support, if you will, that they've been providing?

Corey: Well, what I was about to say is that all of the people that were dwelling in this city were now inside of this time anomaly, for the lack of a better word.

Everyone that was a part of the religious order, until the last minute, are remaining outside of that bubble and are focusing all of their time, all of their energy, on trying to influence the surface population in a positive way to help steer back towards their timeline.

David: So are you saying that it's only the religious order that was doing this before anyway?

Corey: No.

David: Oh.

Corey: No. Many, many from their cities were joining in, but, yes, all of the religious order were taking part. But the Anshar were taking part and some of the subgroups that are with the Anshar were taking part.

David: Do you think that perhaps the presence of these giant spheres in our solar system could in some way help to provide back-up spiritually if these people are no longer able to serve in that function for us?

Corey: When they get to a point where they can no longer really be of service, they're just going to enter that time anomaly and ride it out.

David: Well, but I'm thinking about what that means for us, as these people are kind of like our guardian angels. Would there be other assets that would still help us at that point?

Corey: Well, I think what we would have to realize is that most of this is on us. You know, it's . . . Most of this is up to us. We can't be looking to angelic beings to come and save us or to assist us.

We really need to focus on being the change ourselves.

David: And what would that look like? If they're not helping us anymore, how would we steer the ship without them and get the outcome that we want?

Corey: The steering is going to be done by a very small number of people here. A very small number of people can affect the timeline.

And the people that they're getting in contact with now, that they're going to appear to, that they're giving downloads to, to help them get to a point to where they're ready for open contact, those people are the people that are going to be the feet on the ground of the co-creative consciousness army, I guess you could say.

David: So it's like we're going through our own graduation and stepping into a more active role than we've had before.

Corey: Right. As a part of that graduation, we have to become the masters.

David: Do you feel that there are going to be other events similar to this eclipse, where there will be yet additional sudden leaps forward?

Corey: Absolutely. I think what you're talking about will be born from how people process these downloads they've received.

A lot of people have received a lot of similar downloads that are going to have them coming together.

One of the things that Tier-Eir stated was that in this mission that he's given me that people were going to start just organically just migrating, that are people that are needed at the time.

And I kid you not, we'll say, "We need a person that does this type of graphics or animation," and usually within 24 to 48 hours, we'll get an email, a person say, "I don't know why, but I feel like I would like to volunteer or be a part of this project."

And they have the exact skills that we need, that we were just talking about.

David: Hm.

Corey: And I think that what's occurring is going to start occurring in the macro sense, that all of these people that received downloads are going to start receiving assistance and energy to help them feed and nurture the different projects that were given to them in these downloads.

David: I guess I had this view that we were just going to kind of coast right along up to the flash without anything really that disruptive happening, that it was just going to be this boring, business as usual, nothing really changes that much, and then – poof!

But what you've been saying they're telling you lately strongly implies that even before the solar flash, there are going to be some very noticeable changes in how things are going. Could you explain that?

Corey: Yeah, and I'm glad you brought that up, because in the last update when we described it, I didn't go deep enough. And a lot of people thought it just seemed like fear porn or something pulled out of "Revelations" out of the Bible.

But the way it was described to me is, Mika, a while back, had described what his planet had gone

through. And his planet is mostly islands. It's mostly islands. It's mostly a water planet.

And they were having . . . Just before their solar event and a sentient event, they started having massive earthquakes, tsunamis. They started having all of these types of things, too.

David: Before the flash.

Corey: Before their Ascension. And what was communicated to me was that our planet is a living being.

Most people watching this show will know exactly what I'm talking about. Gaia.

David: The network.

Corey: Gaia! Right. Now Gaia is going through an Ascension. It is finishing its last transitions into fourth density.

And we're kind of like the fleas on a dog, a dog that's going through Ascension, and we happen to be on the dog. We're riding a planet. And we're riding the wave of Ascension, or the wake, I guess you could say, of Ascension that our planet is going through.

David: Hm. Well, you know . . .

Corey: The symptoms of this change is that there are earthquakes, which cause tsunamis, volcanoes explode, that kind of thing. That's just a natural part of the metamorphosis.

David: How disruptive do you think these Earth changes might get before the solar flash?

Corey: I think that they'll be fairly disruptive. It'll definitely have our attention, just like these recent hurricanes that are more powerful than what we've seen prior.

I think that we're just going to slowly get used to seeing more and more things – earthquakes. It might become the norm.

David: Do you think that as we are going through these disruptive experiences that people are going to start to have more spiritual contact, more access, more telepathy, or these types of paranormal events in their lives?

Corey: Yes. And the way it was also explained to me is that these things will be catalysts to push us further into our polarities. As in . . .

I guess right now we're seeing negative people are being pulled more towards each other in negative groups. And positive people are starting to congregate as well. And that's going to happen on a much larger scale.

So this is a very positive thing happening. It is kicking off the Ascension process. And if truly there is going to be a three-way split, maybe how we react emotionally and energetically to these Earth changes will help boost us or determine which polarity we're pushing into.

David: And this is up to us now. We are the ones that have to steer this.

Corey: We are the ones we've been waiting for.

David: Indeed. All right. Well, **Corey**, I want to thank you for all this information. And I want to thank you for watching and supporting our grassroots effort here at Gaia.

I'm [David Wilcock](#) with **Corey Goode**, bringing you "[Cosmic Disclosure](#)", and we'll see you next time.

[Cosmic Disclosure: Viewer Questions 11: Preparing for Ascension](#)

Season 8, Episode 8

David Wilcock: All right, welcome to "[Cosmic Disclosure](#)". I'm your host, **David Wilcock**, and in this episode, we have questions and answers sent in by you that I'm going to be reading for **Corey**.

Corey, welcome back to the program.

Corey Goode: Thank you.

David: Let's just hit the ground running here. First question we have is:

"Corey, what is your personal opinion of what the Ascension event will be?"

You and I have talked about this, and some of the things that you've been told are pretty different from what my own ideas or theories have been.

Corey: Yes. Yeah, that's a good question. The way it's been explained to me, what's going to occur is that when this energy shift occurs, and we fully have the brunt of these cosmic energies interacting with our consciousness, we're going to undergo a consciousness Ascension more than anything in the beginning, that it's going to be a great leap in consciousness. Just the way we perceive everything is going to change.

Now, as a result of that, we start learning more about our co-creative consciousness. We learn how to manipulate matter. We learn how to . . . We gain the ability to read each other's minds, I guess, to communicate that way.

So a lot of wonderful changes do occur, but not in so much the twinkling of an eye, the way I've heard in many different religious beliefs.

David: Well, we are also talking about a solar flash, though, right?

Corey: Correct.

David: So how would that factor in?

Corey: I see the solar flash as being . . . and it's not A solar flash. They are SOLAR FLASHES. It's not just one, all of a sudden, boom, there's going to be a solar flash.

There's going to be poof, poof, poof – flash events that they SAY will lead into a full circumference mass coronal ejection.

David: Right.

Corey: Now, if they're correct – and that's what it looks like – then here on Earth, we're going to be hit with this energy very quickly. And we're already going to be bathed in this cosmic energy that Tier-Eir's people have been buffering from us with these Blue Spheres.

So what I'm told by these beings is that this energetic flash is going to be more of a . . . it's going to affect our consciousness more than anything else.

There are going to be physical things that occur. The fact is that that's what Mica's people went through as well.

Our Earth is going through the final transition into fourth density, and there are growing pains, things happening. And that's just what we have to expect and watch for to see and know what's happening.

Now, the energetic changes and the flash are supposedly going to affect our consciousness and cause us to go through a major consciousness boost, which will then lead to us going through a consciousness renaissance, like Mica's people.

They're not all rainbow people flying around on this planet. And it's taken them a while to get to where they are after their event.

David: Right. So you're seeing that there WILL be some very big shakeups on the surface. Would that include the failure of all electromagnetic devices that some insiders have suggested?

Corey: That would definitely occur during these solar events, these solar pulses that would happen, yes. That's fully expected.

David: So there would be a need to be able to weather through that, the loss of electricity.

Corey: Yes. Yeah. Yeah. You need to be . . . Yeah, that's definitely something that's going to occur.

They expect it's going to basically wipe out the AI influence that is REALLY still a major problem. It's one of our biggest problems.

David: Right.

Corey: It's going to root out any, I guess, water that that fish could swim in, you know, electronics.

So we are going to have to replace a lot of our technology, which is a good time to bring in the newer technology, which, when we're going through this consciousness change, and then we'll have this technology boost all of a sudden, we're just going to start growing like gangbusters.

David: Do you think that once these flashes take place that that authorizes extraterrestrials to be more open in helping us and appearing?

Corey: I believe so. I'm told that after this event that there are going to be two beings that are part of the Sphere Being Alliance and this Confederation that are going to move in and . . .

David: Two beings or two groups?

Corey: Two different types of beings.

David: Okay.

Corey: They're going to move in and basically become like guardians of this new cycle.

David: So losing our electromagnetic equipment doesn't necessarily mean that everybody dies off from starvation, rioting, etc.

Corey: No, and there are a lot of technologies . . . There are a lot of non-terrestrial groups that'll make sure that we have help riding through that transition.

There are a lot of them here right now that are already pledging to do that.

Some of Ka'Are'e's people have set themselves aside to assist us as well as a few other groups that are associated with the Anshar.

David: Well, since we're really getting our hands dirty, let's talk about this as well.

The Anshar told you in the past that they would move people below ground to their Inner Earth areas sometimes to help them ride this out.

Corey: In the past, they had, yes.

David: Do you think that in certain parts of the Earth that things could be disruptive enough that part of this extraterrestrial assistance would involve bringing people to alternate housing, let's say, like a mothership or somewhere underground if the surface of the Earth was temporarily catastrophic in some way?

Corey: From what I'm told, it's not going to be that incredibly catastrophic.

David: Hm.

Corey: It's not going to be . . . I mean, there are going to be strange things.

I was shown a meteor coming into the atmosphere and exploding over the Pacific Ocean, really high up and sending a blast wave that causes a bit of a tsunami. These storms would get incredibly more energetic.

And I was shown the Earth spinning in space, spinning, immersed in this cosmic energy. And as it was spinning, it was like a dynamo that was just building up even more energy.

And that was contributing to the storms getting more powerful and also earthquake and volcanism activity.

David: A lot of channeling-type people are always trying to incorporate the three days of darkness from the Book of Revelations somehow. Do you have any sense as to what that prophecy might be? Is it literal? Is it a metaphor?

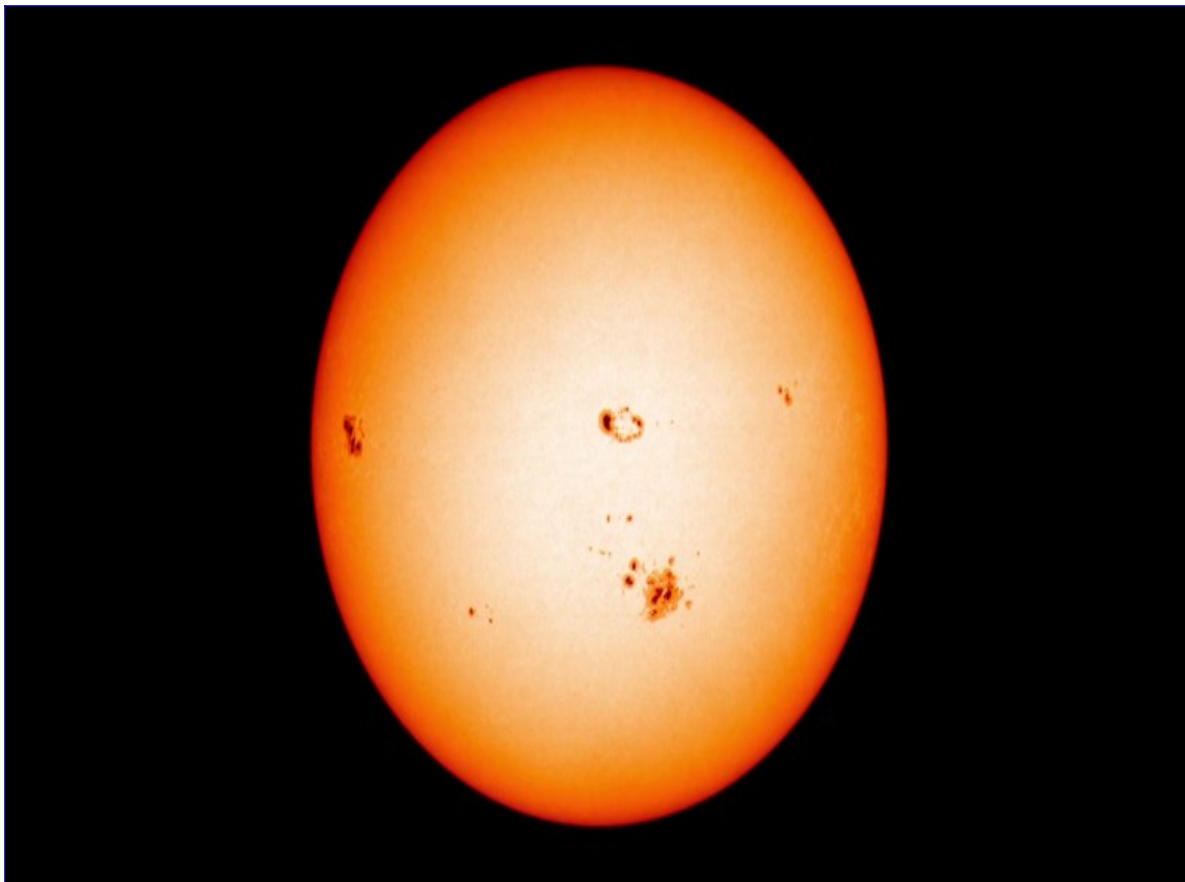

Corey: Yeah, it's literal. When the Sun has that full circumference mass coronal ejection, the Sun will look like when you look at the SOHO images and you see sunspots. It's going to look like a giant dark ball . . .

David: Really?

Corey: . . . for just a matter of days before it completely flips its . . . I don't know if it flips its polarity, but it moves back into balance, is the way it was described. And then, poof, it'll light back up and give its light once again.

David: Very interesting. Very interesting. Well, I guess I'll ask another question. I could go on about this all day. This is my core subject, of course.

Okay, number two:

“Corey, what happens to those who do not ascend?”

Corey: Wow! That's a very complicated answer. There seems to be either a bifurcation of timelines or these individuals are taken to another planet to where they can go through the cycle again – the 3rd density cycle again – brought to a 3rd-density planet. Because our planet is transitioning into a 4th-density planet.

Now, I've heard a lot of people trying to postulate, what's going to happen . . . is there going to be two different Earths? I really don't know the answer to that.

David: Would you think that the time of certain people being moved to another planet would be right around the time that the flashes happen and ETs start to show up openly?

Corey: Well, if they're going to move people, they're going to need to do it just before, I would imagine, unless they're wanting them to be exposed to that energy. There's just a lot we don't know.

David: It is interesting when we look at the Book of Revelations, Chapter 11, Verse 11, when it says that, *“The righteous people who had been shunned by the many will be born into the heavens. And in that same hour, earthquakes shook the Earth.”*

So the Revelations prophecy seems to suggest that there is . . . and this is, of course, where the Rapture thing comes from, but . . .

Corey: Right.

David: . . . seems to suggest there's some sort of removal of people to safety who are like the service-to-others, 4th-density Ascension crowd, before some of the more disruptive catastrophes happen on the physical surface. What would your feelings be on that?

Corey: I haven't heard anything about all of the "righteous" people being removed prior to all of these Earth changes. From what I'm told, all of the righteous people need to be here to experience this solar flash and this energy, full-on energy influx, because that is what kicks off this Ascension or this consciousness renaissance.

David: Oh, this is very personal. Ha, you don't know what these are yet.

Corey: No.

David: "Will **David** ever get to go with you to see the Sphere Being Alliance in the future? And if not, why?" Wow!

Corey: You know, I don't know.

David: You and I have talked about this a lot.

Corey: Yeah, we have.

David: And so, I guess since I'm involved in this, it's not just me asking a question, but I'll dialogue with you about some of the things we've talked about.

Corey: Right.

David: You told me that I was having some problems with not being humble enough, according to these beings, that I needed to develop more humility, and that I needed to develop more of a meditative practice . . .

Corey: That was the main thing, yes.

David: And to de-stress and get my life more sorted out, balanced in such a way.

Corey: Right. Yeah, and they prompted me to give you that remote viewing course from Gerald O'Donnell, . . .

David: Right.

Corey: . . . and they said that that would help you get more into the vibration that you need to be in. And all of those things you mentioned would bring you into vibrational alignment.

David: Right. So I think a real good corollary to this question is something that came in one of your most recent updates, and that is some statements that Ka'Are'e had made.

Corey: Well, hang on. Speaking of Ka'Are'e . . . Now, a lot of people wonder, why don't ETs visit me? They're visiting that person and that person. How come not me?

And she explained to me that to approach a person is not approaching you, [David Wilcock's](#) ego or who you see yourself as.

David: Right.

Corey: They first approach you on a higher-self level. Your higher self authorizes what type of contact you will get, if any.

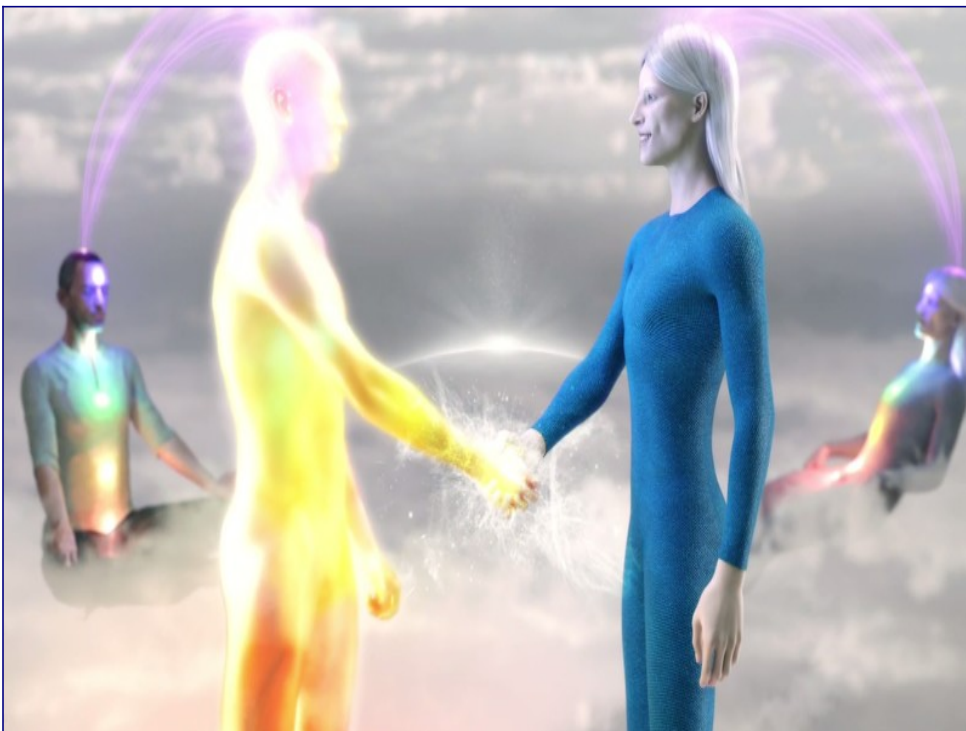

Your higher source authorizes that, and also they'll give you downloads through your higher self, visions through your higher self.

And you think that it's coming directly from an ET. But they're having to . . . But for cosmic law reasons and their own karmic reasons, they're having to approach you on that level.

The malevolent non-terrestrials and humans, they could care less about that.

So I found that very interesting, because I was wondering why you said that you were going to contact these people in dreams, and I didn't hear anything.

And she just let me know that it was a little bit more involved of a process than all of us realize.

David: In short, Ka'Are said to you that there was going to be contacts with others similar to what you have been receiving. So it's not just about me.

Corey: Right.

David: It's about the audience.

Corey: Right. Yeah, it's not about me, and it's not about you.

David: Yeah.

Corey: Right. It's large numbers of people are going to have this type of contact, but . . .

David: What's the sequence? What was she expecting?

Corey: The way she explained [it] is that at first, they approach people – this is before I knew about the higher self stuff -

David: Okay.

Corey: - that they approach people through dreams and to also give them downloads.

Now, during the eclipse, people that were doing the meditations . . . I have a huge report of these people getting all these ideas and downloads and information. So that did occur.

David: Right.

Corey: I'm still waiting to hear for these real interesting dreams to start occurring, which was really how they told me it would first begin.

And then it would move from dream contact, more and more realistic dream contact, to actual physical face-to-face contact in small groups. It won't be on TV.

You might see people with their iPhone video of these beings or something. But they're going to appear to one, two, three people at a time. They're not going to appear in stadiums.

David: And just so we can reiterate this again, if someone were prone to think of themselves as a messiah, or special, or a savior, or enlightened, after having had this happen, it wouldn't be a good thing, would it?

Corey: No. They will not even attempt to do contact with those people.

Like in the '50s, they started contacting people, these different non-terrestrial groups, and the people started developing these Christ complexes.

And that's very difficult even for the most humble person not to develop with all the programming we've had. So they had to withdraw from that quite a bit.

So that's another good reason why they don't just appear to people.

David: So if the advice that was given to me might in some way be generalizable for more people, I thought that I was doing fairly well with humility. I mean, I don't feel like I'm out there projecting a huge ego.

How might the average person still be needing to develop this quality of humility? What would that involve?

Corey: Well, the average person has so much programming, so many personality distortions that they haven't focused on and dealt with.

It all goes back to the Blue Avian message for us to focus inwardly instead of outwardly. All of us are . . . We're looking up. "Show me. Show me." But we should be looking in.

Inward is where all the answers are going to come from – developing your connection to your higher self, developing a quiet mind, these meditative practices. These are all things that are going to get you in alignment.

When you're focused on the outward, the ego, the outward, your vibration is completely different, and your outlook is completely different.

David: There is a really interesting "Law of One" quote about humility that I think we could bring up now, which is that, "It is lacking in humility," they say, "to see yourself as separate from others and separate from the Creator."

Corey: Uh-huh. That's ego. That's where ego comes in, how you're distinguishing yourself from everyone else.

David: Right. So it's much greater humility to realize that you are one with all.

Corey: Right.

David: And then they say that means that you consciously recognize yourself as a servant of all.

Corey: Right, and that also . . . Most people . . . When I mentioned ego to you, you immediately – you know, you live in L.A. - you're immediately like, "Oh, you're thinking big head, you know, walking around with your collar popped up kind of thing, you know."

But you just described what ego is. It's how we see ourselves. It's how we differentiate ourselves from everyone else, who we are, being all wrapped up in that ego and in the physical things in life, are really what they're talking about.

David: Sort of identifying with your body more than your soul, you could say.

Corey: Right. Right.

David: Okay, next question:

“How many people . . . “ – I don't know if you can answer this or not; we'll try it – “How many people are you aware of who have been in certified contact with the Blue Avians?”

Corey: Hm. A lot. That number has been growing and growing.

For some reason, most of the people that have been in contact with the Blue Avians and having Blue Avian contacts, many have written me in emails. And they're very legitimate contacts. But they do not want to talk about it. They do not . . . Or they've been told to keep it quiet for now. So I am not the only person out there meeting with the Blue Avians.

They meet mostly in dreams with people, and they can look slightly different. They show their selves slightly differently to people.

David: Right.

Corey: And sometimes the people's psyche will interpret it differently. They'll come back and say, “Well, I saw a white bird being, and this being does all of the things that the Blue Avians do.

So I don't know if it's them not being able to interpret what they're being given correctly, or maybe the Blue Avians are appearing differently to different people.

David: So to quantify, then, how many people, what would you say?

Corey: I have no idea.

David: Maybe hundreds? Maybe thousands?

Corey: I'm sure it's in the thousands.

David: Yeah. Okay, next question:

“Does Ka'Areë know that she is becoming well-known here on the surface? If so, is she comfortable with you sharing your encounters with us?”

Corey: Yeah, she is very aware. The Anshar are very aware.

One of the things that's been occurring is that since we've reported her existence and the existence of the Anshar, many, many people from the surface of the Earth have been reaching out to the Anshar psychically. And it's something that they weren't quite accustomed to.

They're accustomed to reaching out to the surface population.

David: Right.

Corey: And many times, as I had explained, in the past, they had used deception and told us, “We come from the stars,” when really they were from below their feet. It was just an operational security thing.

So they're very aware of how much we are focusing on them.

They want us to, again, like the Blue Avians do, focus inwardly. But she does tell me certain things that I should not share.

David: So you would say, then, that she is aware that speaking to you is having you be her messenger. And she wants people to be aware of what she's saying.

Corey: Yes, the Anshar are very concerned right now. The temporal anomalies have been occurring that are very similar to the Mandela Effect with them.

Again, they've been having things that have been showing that they're not quite on the right . . . they're getting off the right timeline, and they're freaking out about it.

And they've taken some pretty strong measures recently that I've reported in my update.

David: Okay, here's the next question:

“You mentioned that Ka'Aree said the Anshar have masqueraded as gods in our history. Has she ever said or implied in which region or timeframes these appearances have occurred?”

Corey: When I did the mind-meld with her, I was . . . She's only – only, ha – she's 130-ish years old. So in that time period, she wouldn't have gone back to ancient times.

It wasn't shared with me which of the gods were her people or some of the other non-human groups that were visiting them.

So as I was mind-melding with her, I saw her visiting with, it looks like, '40s, '50s era uniformed personnel from, it looked like, England. It looked European. I think it was England and the United States.

So they were presenting themselves as being from a certain star system when they were meeting with these military officials.

David: Okay, this next question . . . I think you can clear this up, but it's an interesting one, and it'll help to be cleared up by what you say.

“When the Anshar people landed on this planet 20 million years ago, were they considered third or fourth dimensional beings?”

Corey: Yeah, it was around 17 million years ago. Yes, they were fourth-density beings that came from our future.

So when they traveled back in the past, they did not get demoted in the density scale.

So for approximately 17 million years, we've had fourth-density human beings – I guess we would call them “human” - the new iteration of humans – living below our feet.

David: Would you say that they were more advanced by that point than where Mica's people are now?

Corey: Oh, absolutely.

David: Okay.

Corey: Yeah, this was far into the future after they became fourth-density that they started noticing these temporal anomalies and then went back into time to try to preserve their timeline.

David: Are you aware of whether this time travel was a technological process? Or is it something they could actually achieve with consciousness and a knowledge of portals?

Corey: Their technologies . . . All they do is magnify their consciousness. Their craft, everything . . . They are consciously interfacing and powering the devices with their consciousness.

David: Hm.

Corey: If they were to give us one of their ships, it would just be kind of like a shell with . . . We wouldn't really fully understand it, because a critical component is missing, the pilot. And the pilot is the power system, the flight controls. All of that is done through consciousness. That's why they use crystals a lot.

But they are so far beyond us, us trying to understand . . . We understand things in a nuts and bolts technological way. They are just so far beyond that that we really can't even comprehend it. We can just kind of comprehend it.

David: I would imagine that people like Ka'Areë would be able to do telekinesis. Did you ever see anyone there moving things with their mind?

Corey: No. No. No telekinesis, but they definitely have the ability to interface with people in a very powerful way. But I have not seen them using any telekinesis.

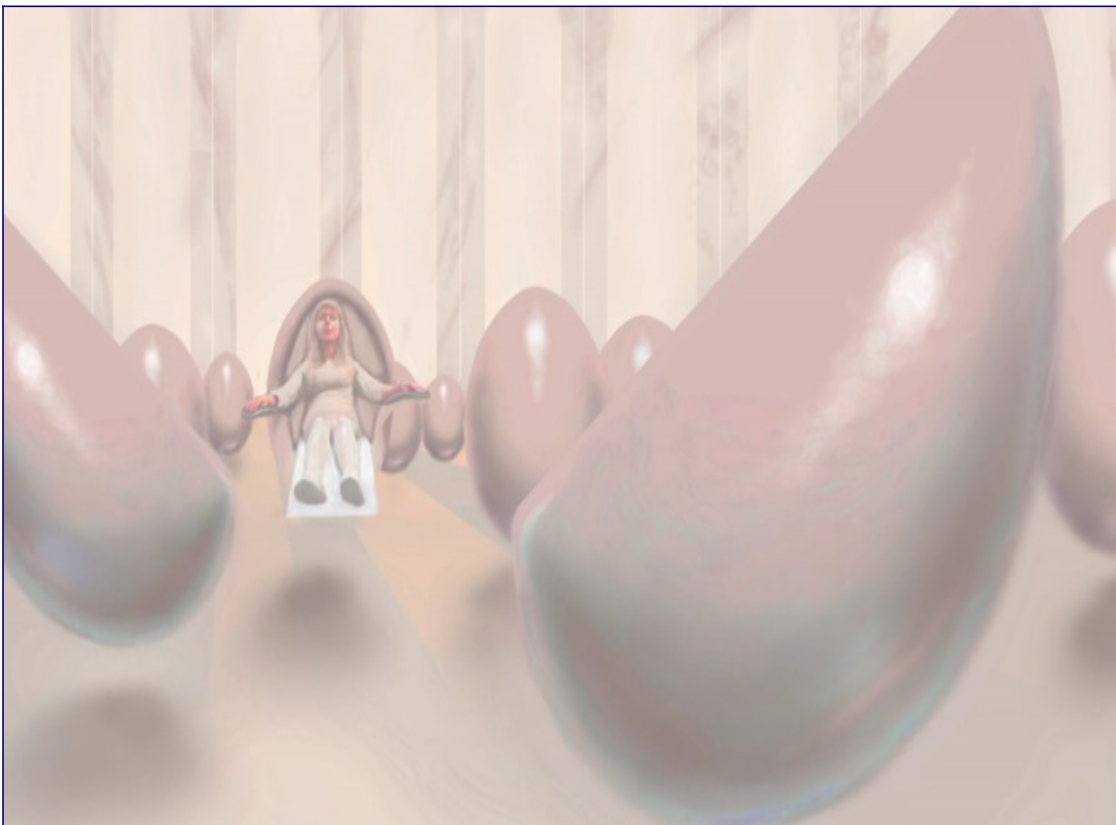

Now, I've seen other beings walking onto a craft with crates, tight crates, like floating above the ground. But they're not using telekinesis. They're using this consciousness technology that to us would look like magic telekinesis.

David: Do you know if . . . When you saw the Anshar sitting in those pod-like chairs telepathically interfacing with us, do the chairs levitate on their own, or are the people levitating the chairs?

Corey: Well, the chairs . . . the empty chairs were levitated also.

David: Oh!

Corey: Now, a lot of the things that operate down where the Anshar were in their city, it was kind of like each person down there was contributing a certain amount of voltage and consciousness wirelessly to all of this technology.

I don't have the capacity to fully understand. And you take the most brilliant person here right now on the planet, and they're not going to be able to follow it either.

Our minds cannot wrap around these concepts.

David: “What do you know about the identify or intention of any ancient gods, based on anything you did hear or learn from the smart pads?”

Corey: I think the intentions can be relayed in the stories about the gods that we look at. A lot of those are based in truth.

Who those gods are a lot of the time, it's really down to our own personal belief systems. A lot of people are like, the Anunnaki or the Reptilians – and only!

And yeah, they were, but it also encompassed other groups that were interacting with human beings, and they received that name.

David: Wouldn't you say that the people in the Cabal, to some degree, still feel as if they are the sort of vilified gods, and that they want to restore their godhood over the planet?

Corey: Yes. That's exactly what they believe. They believe that their lineage comes from off this planet. Their lineage created the genetic stock or the cattle that they are here to manage. And they feel entitled.

David: All right. Well, thank you for answering our questions. I'm sure we're going to have more of this. And thank you for watching. This is "[Cosmic Disclosure](#)". I'm your host, **David Wilcock**, answering your questions with **Corey Goode**.

Cosmic Disclosure: Zuni Disclosure with Clifford Mahooty

Season 8, Episode 9

David Wilcock: All right, welcome to "[Cosmic Disclosure](#)". I'm your host, **David Wilcock**, and we have a special extravaganza for you: indigenous wisdom from none other than **Clifford Mahooty**.

And here also with me to join in this exciting discussion is **Corey Goode**. **Corey**, welcome to the show.

Corey Goode: Thank you.

David: **Clifford**, welcome to the show.



Clifford Mahooty: Thank you.

David: So **Clifford**, tell us a little bit about what tribe you represent, and why you've decided to come forward on the show today.

Clifford: I'm from the Zuni Pueblo Indian tribe from New Mexico.

And the reason I decided to come and talk with you folks today is because I think that we have a lot of information that has been kept within our Indian communities for a long time.

And with things that are happening in the world, I believe that there's a lot of connections with what we have known for centuries, or at least my ancestors.

So I believe that it is time to talk about these things and to let the other people know about what we have had for many, many years.

David: So **Corey**, could you tell us briefly why you wanted to bring **Clifford** onto the show? What were some of the things about what he said that excite you the most?

Corey: It's definitely time for a Zuni disclosure.

There are a lot of correlations, a lot of things that I saw in the programs, that did mention the American Indians.

David: Mm.

Corey: So recently he was at a conference and the information that he was giving was very important, and it seemed to tie in with ancient aliens, secret space programs, and how the government is working with the Native Americans to keep certain things still secret.

David: So **Clifford**, how does this language get passed down from one generation to the next?

Clifford: Zuni has an oral history. And since the day you're born, you're taught the language by not only your parents, but also the extended family system.



And so the language . . . That's the first thing that you learn is the Zuni language. And later on, you pick up the other language, in this case would be English.

And so all Indian families, if Zuni, that's what they teach first.

David: Does every Zuni get the kind of lineage teachings that you are carrying with us today, or is this something that you have to get sort of a special insight to learn?

Clifford: A lot of information is not passed on any more.

David: Hm.

Clifford: When I did some videos and we sent that to some of the people, the young generation in there, they always have that saying of, "Oh, that's what that's all about."

And I explain to them what the history is all about and where this type of application is generated so they have this thing that, "Oh, yeah, well, that's what we have been taught, but we didn't know where it came from."

Corey: And as you got older, they asked you to actually record the history, did they not?

Clifford: The oral teachings teach you how to know about the history. There's many ways of approach to this.

First of all, it's the stories, the mythology, the teachings of mythology, sort of like Aesop's Fables. What's the meaning of the story?

Your mind starts looking at things in a picturesque way. And then you learn how to relate a lot of different ideas into your head, without even looking at pictures, just by word.

And as you get older, then they start introducing other historical events and also things that are sacred.

David: What would the average Zuni who's been brought up on this feel about extraterrestrials and things like this?

Clifford: Well, there's two things actually. One of them is that if you see orbs, or if you see things that represent like a fire in the sky, they take that as bad omens.

David: Oh!



Clifford: But if you take, for example, like an orb or a flying saucer-type things in the sky, then they say, “Well, those are the Keepers or the Guardians.”

David: Really?

Clifford: They'd always been part of our history. You look back at, for example, in the petroglyphs, any petroglyphs that you find anywhere in the United States, is that you'll always find a reference to a flying saucer and also other activities that were related to the sky. So we knew about flying saucers.

We didn't call them “flying saucers”. But it's part of the system that you don't learn until, again, you go through the step process.

Some were . . . When you become older, then you're taught about different things, like for example, the Kachina people.

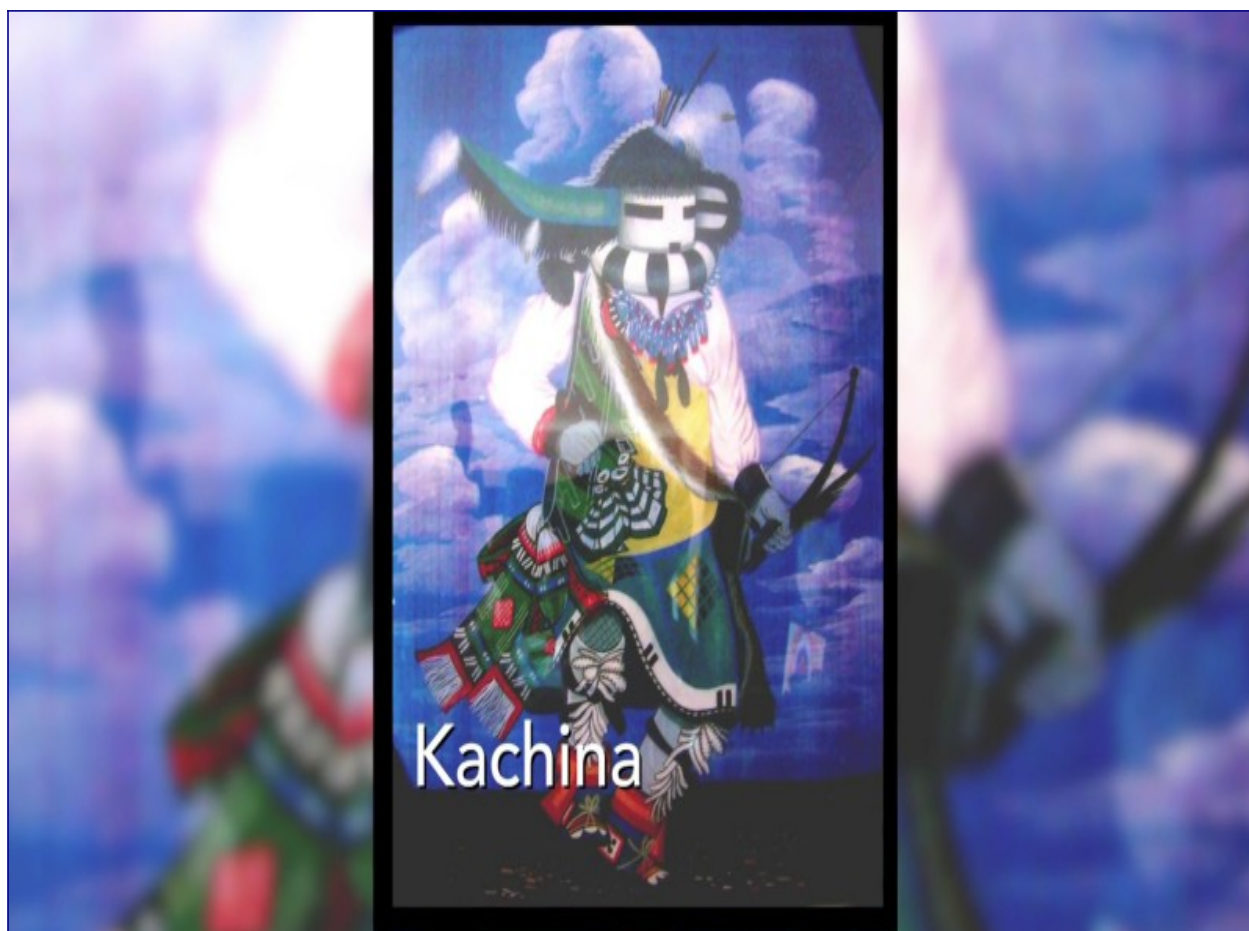

A Kachina is a representative of what used to be ETs when they first came to our people when we were still in the developmental phase and they were still in the teaching stage of teaching the American

Indian indigenous tribes of how to take care of themselves and the Earth and other living things and also the connection.

Corey: Yeah, farming, all the different civilization . . .

Clifford: Technology.

Corey: Technology.

Clifford: Includes agriculture, farming, how to build things, and how to relate to other different god systems.

So those are our transitions that were made throughout history, simply for the reason that . . . One of the reasons was abductions by the early ETs way back in times past.

So they went into what they called a Kachina society. So we take the place of those people.

But the thing about it is that they say that you become those people in spirit and in the ways that when you become a Kachina person, you become that individual. And they're always there with you, even though you can't see them.

David: So **Clifford**, in videos where you've come forward before, you explain that some very important things started to happen to you when you were 22 years old.

Clifford: Uh-huh.

David: Would you tell us a little about that?

Clifford: We started a program called "The Information From The Elders". And that's where this information started gathering in one source.

At that time, we were running a program to get all the elders of the village to give us their stories of what they knew, what is the mythology, what is their own life experiences, and basic history of what their grandfathers and their grandfathers' grandfathers taught them.

So we started accumulating this information. And one of the things that was very interesting was that

there was a lot of stories about the Sky People, about the flying saucers at that time.

And this was probably in the mid-'60s was the heavy activities of flying saucer interventions that were occurring throughout the whole nation, but it was not really known outside. But we have had known that for centuries, thousands of years, as a matter of fact.

Corey: These were audio recordings that they were doing of the various elders?

Clifford: Yes. We had tape recorders. And I think one of the most interesting one was that one of the grandfathers talked about way back in the '50s they had a big drought in Zuni, so he had to take his herd of sheep to this dam.

And when you got there on the dam, there was a flying saucer sitting there on the dam.

He said that he went over there and met those little people about three or four feet high, three of them. And they talked to them.

And the interviewer asked him, he said, "What language did they talk to you in?"

And then without thinking, he just said, "Well, they talked to me in Zuni."

So that was very interesting that they can talk in any language.

David: Clifford, I've done a lot of research into this idea of ley lines in the global grid.

Clifford: Uh-huh.

David: There are definitely reports of Bermuda Triangle type phenomena, things appearing and disappearing in what most people call portals.

Clifford: Uh-huh.

David: I'm wondering if you have ever had any of those kind of things happen in the Zuni land?

Clifford: There has been stories about it, but we do have what we call "sacred sites". They were created or put in place by what we call the Ra people, or in this case the Star People, and other . . .

But there are certain places that only certain people that are of that order can only participate in the activities related to those portals, those extra-dimensional doorways, if you want to call them that.

Corey: And lots of military activity around them as well.

Clifford: Oh, absolutely. Really recent . . . Within the last, I would say, within the last 20 years that I'm familiar with, that there have been . . . the Zuni has become a place where there's a lot of military activity coming down.

And then if you see an orb or an anomaly, within 15 minutes there will be a helicopter there.

And I say, "Where do they come from?", because the nearest Air Force base is 150 miles – Albuquerque, New Mexico.

David: Hm.

Corey: I was telling you last night, when we were driving through the Grand Canyon, we saw Chinooks flying into the heart of the Grand Canyon.

What is the U.S. Army doing in the heart of the Grand Canyon?

Clifford: Uh-huh. We have also evidence in Zuni of a lot of things that have been restricted against a lot of the people not to go certain places.

And I think I also mentioned places like Archuleta Mesa, . . .

Corey: Uh-huh.

Clifford: . . . where a lot of . . . Even those people that are there, in this case the Jicarilla Apache Indians, they're not even allowed to even go to those places.

Corey: Well, didn't the government come in and give casinos and that kind of a thing as a trade in order to get access to a portal to build some sort of Department of Energy . . .

Clifford: I believe that there were some type of agreements there, because the Indians really don't talk for themselves, because they're run by the Bureau of Indian Affairs, which is a government agency

under [The Department of the] Interior.

So those are the ones that negotiate the casinos and any activity on the land, including the resources.

So in this case, if they wanted to put in a military or some type of activity on the reservation, they have to go through that, because no Indian owns any land.

David: Well, what do you know about the Archuleta Mesa? What's going on up there?



Clifford: Well, there are so many stories that have been . . . Remember that one where they broke in and there was tunnels in there, and there was also some alien base that was in there.

There's a lot of alien bases that I have heard about by very reputable people, but they have been there for a long time.

But I believe in that case, according to the information that's out there in the public is that they broke

into that some time back when they were doing all those different tunnels that were going to different bases, whether it's from Los Alamos, Area 51, places like that.

David: Have you ever heard about unusual creatures running around the Archuleta Mesa, like as if some experiments got loose?

Clifford: I've heard so many of them. First of all, the main guy used to be Bigfoot, which was pretty common among all the Indian tribes.

But lately, within the last 10 years, I would say, I have become aware of some of the different creatures. And I'm looking at it from two standpoints.

First of all is that there is a high activity of what they call the "Skinwalker activities". And those are the ones that . . . The dark force people are the ones that can convert into any animal they want, whether it's a wolf or whether it's a coyote or whatever.

And then the other group is the one that there's been some sort of like dinosaur-type-looking animals that have been appearing in a lot of canyons, especially around the wilderness area, like the Archuleta Mesa.

David: Huh!

Clifford: And the third group is probably something that I have heard about in many experiences that have gone mad, or at least I think that either they escaped or they permitted them to go out there.

They seem to terrorize a lot of different people out through especially places like, for example, where the Los . . . I mean, the Sandia base. There's also a lab there that a lot of Indians know that used to work there that talk about some of the experiments that were down there.

Of course, they were like people that took care of the janitorial services-type people, but they were not allowed to go into the high-secret areas. But they heard about them.

So there's a lot of stories that are out there.

Corey: You mentioned a dinosaur-type creature.

Clifford: Yes.

Corey: Any more descriptions on them, like do they have like little feathery things or anything like that?

Clifford: Well, most of the ones, they were about maybe about four or five feet high, but they were like two-legged. They would jump around. They had tails.

But these are people that did not want to be . . . you know, have their names said who they were, because they were afraid. It's just like anything else.

Corey: Yeah.

Clifford: It's just like back in the old days when we talked about UFOs, you'd be ridiculed.

Corey: I was just thinking, your secret kind of societies within the Native American orders that have contact with these off-world beings, it's very similar to what's going on in the rest of the West with people or organizations that are secret societies having connections with off-world groups and then disseminating information to the people, but it being just very few people that have that access.

Clifford: A lot of those people that belong to those groups, it's within their . . . I believe that it's in their family. It's within their DNA. And they were created . . . When the Earth people were first created, they were created along with the rest of the other people.

And in the Zuni teachings, they were only supposed to be the balancer of life. In other words, that their purpose was to make sure that there was no overpopulation. It was a safeguard.

However, it went out . . . They can no longer control them. And they start interconnecting with other groups throughout the planet, which probably came from different systems, star systems, because Earth, according to the Zuni history, was that this was a water planet.

And we believe that the gods were the ones that created this, but we were already here. They just upgraded the humans.

We did not come . . . According to the Zuni, we did not come from any other planet. We were already

here, but they upgraded us with their technology and their methodologies to bring us up to speed on a lot of . . . especially in the intelligence, the spirituality.

David: That sounds very familiar.

Corey: Yeah. And also, were there not tie-ins between the Zuni or the Hopi and the Mayans?

Clifford: The Mayans and the Hopi and the Zunis are of one stock. And one of my lectures has been on when Lemuria sunk. And that's where they migrated over here. And they had to separate them because there are so many of them.

Corey: So the Chaco Canyon were associated as well?

Clifford: Yes.

Corey: Because they disappeared about the same time the Mayans did, correct?

Clifford: There's a lot of theories about those type of disappearances. Some of the diggings at Chaco, they saw that . . . they theorized that there was also cannibalism that occurred.

And the other one is that the red-haired giants came in there and also the enemies that came in to the Chaco culture and actually just took over their population and they split.

Corey: Growing up, my granddather was Cherokee. And I would hear stories about red-haired giants, and about how they once had a huge civilization that covered everywhere from the East Coast of the United States all the way down to Central America.

And that after a great cataclysm, their society or civilization fell, and they never recovered. And at the end, they were resorting to eating human beings to a point to where natives were hunting down the red-haired giants.

Clifford: Uh-huh.

Corey: And we talked about one story about how they would chase the red-haired giants into caves and then light a fire at the mouth of the cave to suffocate them.

Clifford: Well, if you go to any petroglyph, you can always see a giant there.



But the giant, the red-haired giants, for example, they were very prevalent, especially around Utah and Colorado, because right after the Ice Age is when they start appearing, according to the legends.

And there's even some burial sites in Nevada that a lot of friends have told me about that there are actually red-haired giants that are still in there, because they didn't want to let the other people know, because all they'll do is take them and that's it. So they just left them there.

If you look at it from the Anunnaki connection, especially around the Eastern Seaboard and in the middle of America, there's a lot of those legends that is among ALL Indian tribes.

But the red-haired giants disappeared, like you said, I think either because of the climate change or they just were . . . the Indians took care of them, because . . . even clear down to Arizona.

Corey: Even the Spaniards reported seeing them when they first came.

Clifford: Yeah. I think that . . . There's a lot of history. And I think what they did was they went somewhere. Maybe they went underground. [**Corey** points down.]

Corey: Maybe they did.

Clifford: Or somewhere that they had to find a refuge.

David: So **Clifford**, you also have some really interesting information about the Los Alamos military base [Los Alamos National Laboratory] as regards to the Zuni. Could you tell us about that?

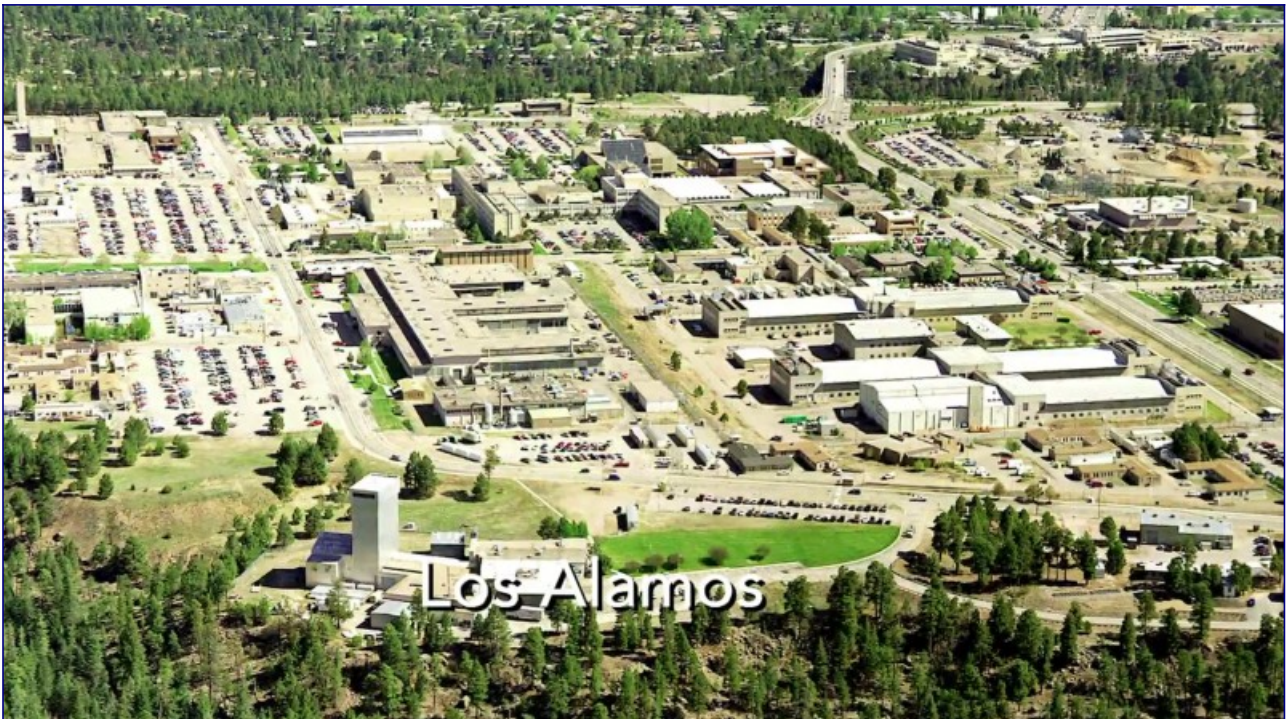

Clifford: Well, what I understand about Los Alamos is that that's one of the portals very important for all Indian Pueblo tribes.

And that is where a lot of your society's systems were generated from, especially the medicine groups and other organizational groups that are in existence still to this day.

And they came from . . . For example, like in Zuni, they talk about the Milky Way galaxy that . . . the portal that goes out of Los Alamos and distributed the different types of societies throughout the Pueblo people.



Mesa Verde National Park



So my theory, or at least just based on upon the teachings and the songs and the prayers, is that when they came through the portal, there's a lot of sacred places. The nearest one would be Mesa Verde in Colorado and Chaco culture.

Corey: You were talking about how not only the government are interested in sacred lands because of the portals, but also the Catholic Church for years has moved in to try to find sneaky ways to grab sacred lands.

Clifford: Well, the good example is the one over at Mount Graham, right next to the San Carlos Apache Reservation is by Globe, Arizona.



And Mount Graham, I did not know at that time, when I was working as a government person, is that the San Carlos Apache medicine man – and his wife was also a medicine woman – they were protesting that that is a sacred mountain. And I didn't know why they were protesting that.



But later on, after I left, they built – the Catholic Church – built that big telescope.



Corey: So you think they're using those portals somehow?

Clifford: There's a portal there. It's one of the biggest ones, according to that group down there.

And there was actually a portal that used to . . . and they set it right there on that sacred mountain. And when they opened it up, there's a lot of people that – scientists and engineer types – that went over there to inspect it before they put it into use.

That's when I learned that it was financed by the Catholic Church.

David: It appears that the science of these portals is you could have sacred land, but unless you know when the portal opens, nothing that magical is going to happen.

Clifford: Uh-huh.

David: So I'm wondering if your people were involved in the timing of when these things . . . Did they track time and did they understand when these portals would open?

Clifford: What I have learned, which I . . . not directly, but indirectly, is that these people that are versed in those activities, there's many, many different societies. And they call them priesthoods.

The priesthoods are the only ones that can go in there. And they go through whatever procedure that they go through to go into or talk to those people that are coming through those portals, or that they're there.

And that's the one that that I have never got any information on, because I don't belong to those groups.

So there's actually people that have been in those orders that can go over there and talk to the . . . whether it be the upper world or the inner world people. And, of course, they're all termed as gods.

So when you take a place . . . When you become those individuals, you're trained to go over there, and you can talk to them.

And I have been told by many people that have authorities that they can actually open those places.

You know, it's be just like big rocks in there. They do the chants, and they do the prayers and whatever, and it opens up.

Corey: So you've heard of seeing a rock face, and it opens up into a walkway?

Clifford: That's what they have . . .

Corey: So that's what they see the portals do.

Clifford: Yeah.

Corey: It's not necessarily an energetic thing, but the actual rock opens up?

Clifford: Mm-hum.

Corey: Oh, interesting.

Clifford: Yeah. And there's a lot of places, especially in the Grand Canyon. There's places inside the Grand Canyon that I'm aware of by . . .

Corey: We've heard of hikers that have seen that, that have seen openings open and close.

Clifford: Yeah.

Corey: Yeah.

Clifford: And then they go in there. And then even one person dropped a rock to see if it will hit bottom. It never hit bottom.

David: Ha, ha.

Clifford: I mean, these guys would not . . . These are very high spiritual leaders.

David: **Clifford**, you've talked about a Zuni prophecy of how the Earth is going to go through a healing. Could you explain to us what that prophecy is, and what might we be seeing?

Clifford: Well, according to my teachings by my grandmothers, grandfathers and elders, we always have that leeway to go back and try and fix things. And it has to be done in a full effort. It's just like any other conscious awareness.

But if we start practicing it today, there's always forgiveness by the gods. But it has to be done totally.

It's just like when we used to do a rain dance. Out of 100 people that are participating in a rain dance, if one of them doesn't have their heart in it, it's not going to rain. So it has to be a total effort. And that will be the hardest thing, to get everybody on the same page. But it can be done.

I have no doubt at all, because if you put in your . . . and we've done it. I have been involved with those type of activities, where it can happen.

But we have to get rid of the other influences, especially the dark energy forces people. You have to get them to convince them that we're also doing it for your own good too, because you're part of this whole system. So that has to be happening.

Corey: Well, it's encouraging that you keep saying “we” instead of “they”, because that puts it back in our hands as a people . . .

Clifford: Yeah.

Corey: . . . that we are the ones that can fix this.

Clifford: Absolutely.

Corey: We don't have to wait on someone to come and save us.

Clifford: We have always said that. And we have always talked to our enemies in a way, when we were first encountered. This is the way it's supposed to be, but they never listened, because their agenda was different.

But there's many winning ways to do this. And I think this next generation that's coming on will be that group. I totally believe in that, because they're now . . . they got rid of the old stuff and they're looking for the new way to do this, still with the DNA in them, with all the teachings within them.

And I go through this example of when we had the Indigos, and then the Indigos followed them. And now we're at the Crystal Childrens, and then now we're at the Rainbow. And I think the next group will be the one that will carry forth that effort, because they're now more advanced. And they're not . . .

they're not set in the ways that we were set, you know, by different sources, whether it's been the federal government, established religion, because they distorted our way of thinking.

So these new wave would be the one that's already got the information. They've been downloaded, including the Indian Pueblo side of it.

Corey: And now the Zuni are, I guess, taking the first step and coming forward to share some of these correct prophecies and more about your culture. That'll bring people together in that way.

Clifford: My generation, you know, we've already passed that stage of . . . we were indoctrinated too much. So I think that the next generation will be carrying on. They have to dig out this information. That's why I'm doing my part to at least put that seed in their thinking so that they say, "Oh, at least we have a resource. We've got the technology."

David: All right. Well, that's a great line for us to end the show on. Thank you, **Clifford**, for being here.

Thanks, **Corey**, for bringing this amazing elder to our attention. And thank you for watching. This is [Cosmic Disclosure](#). I'm your host, [David Wilcock](#), with our special guest **Clifford** Mahooty and **Corey Goode**.

Cosmic Disclosure: Hopi and Zuni Prophecies with Clifford

Mahooty

Season 8, Episode 10

David Wilcock: All right. Welcome back to "[Cosmic Disclosure](#)". I'm your host, [David Wilcock](#), and we are here with our special guest **Clifford** Mahooty, who was brought to our attention by our insider's insider, **Corey Goode**. So continuing this fascinating discussion, here we are.

Clifford, welcome to the show.

Clifford Mahooty: Glad to be here.

David: And **Corey**, thanks for being here.

Corey Goode: Thank you.

David: So **Clifford**, we are now going to start talking about some of these very interesting artifacts that your people, the Zuni, have had in their possession.

You have said on public record now that you believe they have off-world artifacts. Could you be a little more specific?

Clifford: I believe one of the first off-world things that I learned about was the crystals. And these were both used as transmitter and receiver, so I guess they would fall in the category of transceivers.

David: Hm.

Clifford: And they would use these for communications with other groups, in this case, probably some of the sacred groups throughout the land here on the planet, and also other places.

And there has been some artifacts that had been saved throughout the years, but most of them are now in the hands of those people that don't know what they are.

David: So these look like regular crystals, or do they have a sculpted look? Or what would we see?

Clifford: They come in different forms. Some of them are natural. Like if you took a quartz crystal, for example, they have the same size. And some of them are round – the crystal balls that they use for looking in there, especially in the other societies and other groups throughout the world.

And I also have studied that in terms of what they use now in computers. Computer technology is also used in the crystal technology, primarily for storage.

And I believe that they use this as a bank of information which could be infinite. And, of course, they also connect with other, perhaps off-world or inner-world systems that they can transmit messages and probably viewing through those, those technologies that have been in existence since, I understand, since the beginning of the Indian culture and people.

Corey: So the crystals actually store information.

Clifford: Yes.

Corey: So that's kind of a little bit of a correlation. In previous testimony on [Cosmic Disclosure](#), we talked about the Inner Earth group, the Anshar.

And they use crystals as giant, basically, computers. It's data banks for information.

Clifford: Uh-hm.

Corey: So that's kind of an interesting correlation that they can store information in them as well as use them as a transceiver to communicate with, I guess, people from space and people from the inner world as well.

Clifford: I think they're from all different dimensions, if you want to look at it that way, not only the dimensions that we as humans are aware of. But I think that they also go beyond other dimensional areas or zones, or perhaps in an interdimensional type of system, which I really don't have any idea about. But I think that these messages are received instantaneously in most cases.

And a lot of that among the primitive tribes have been used for the healing practices. And the healing practices is also used of [by] other groups to also interconnect with other, perhaps, inner world, off-world, and even on the surface systems for transfer of knowledge that is so required at that time. And it's usually done without any language.

It just, I guess, in a way, just transmits in a different zone . . .

Corey: Thought.

Clifford: . . . for communication. The thought processes.

Corey: Right.

David: So **Clifford**, were there any other artifacts that the Zuni got from the star people that you're aware of?

Clifford: I believe that there was many things that were given or survived throughout the thousands of years, but most of them were taken out by the early explorers like the Smithsonian.

And there's a lot of records. And I even saw them way back in the 1960s, of some of the stuff that they took out from Zuni throughout different expeditions starting back in the 1880s.

And they even went and dug up some ruins, the original ruins that were there in existence during the Spanish invasion. And so those artifacts were stored in the Smithsonian.

We went back years later to ask for it, but they told them that they had gotten rid of them or they couldn't trace them back.

But I saw them back in 1966, some of the masks, some of the paraphernalia that they used for religious and curing purposes, and also some of the original artifacts that they recovered from the tribes.

And so there are many things that were in other different museums, like the Hyde Museum in New York and other museums throughout the country.

After the Indian Repatriation Act and the Graveyards Protection Act, they gave a lot of it back to the Indians, but we don't know exactly what the process was.

Corey: There could have been technology, off-world technology, involved in what the Smithsonian removed, because you mentioned before that there was . . . speak of “flying shields” that were handed over to the native population, and they actually flew in them.

Clifford: Not only that they used the shields, but other vessels that they used for transportation in the old days.

David: When you say “shields”, I just want to be clear. Are these like sculptures that are meant to look like flying saucers, or are they actual craft?

Clifford: It's a craft, but it looks like a shield, the flying shields.

David: Oh!

Clifford: A reference is also made of the flying gourds, which are round vessels.

David: Ah!

Clifford: So because at that time, what would they relate it to?

David: Right.

Clifford: It's something that they were familiar with.

So the shield, in this case, would be something that you guard yourself with . . . against. Most Indian tribes had their shields back in warfare days. And so that's the only reference that you can make.

And if your flying shield is flying around, well, that's the only reference that they had.

David: You may be aware that here on Gaia we've been investigating some very unusual, humanoid-looking mummies. Have you had any encounters with possible artifacts of that nature?

Clifford: I'm only aware of them through information that was given me. For example, the one that this Hopi person told me about is that, . . . especially in the ant people that the Hopis are very familiar with.

Now, I've heard of other mummified beings like the one that they took out of the Chaco Canyon, according to this same individual, that was inside of a log that they transported from the Chaco to Hopi.

David: Hm.

Clifford: From my first glance, it's mummified. But it also has a covering on it that looks like . . . If you look at a piece of mahogany wood or a root, a mahogany root, and it's like polished. But I can sense immediately that there was something that used to live as a living being.

But it's about . . . I would say it's about that long. [**Clifford** spreads his hands about 30 inches apart]

David: You're saying it was actually glossy?

Clifford: Yeah.

David: Like a glossy polish?

Clifford: It was some type of sap on it or some type of a compound that was in there.

David: Like for mummification.

Clifford: Yes.

David: Wow!

Corey: Well, they've probably seen . . . Over the years, they'd find tree sap, and then there would be something preserved in it like a bug or something like that. They probably knew that they could preserve . . .

Clifford: The way I look at it, that they were taught that from the off-planet beings on how to preserve those things. We were all taught by those people.

David: Now did this mummy look just like a regular human three feet tall, or did it have some unusual features?

Clifford: It's got many, many unusual features. It didn't look like a human at all.

David: Really?

Clifford: Yes. It looked like . . . My first reaction is that it's an ET because I've seen so many pictures of them.

And what my evaluation of the information that I have studied throughout the years is that that's got to be an ET or off-planet living thing, or something that came from not a human or regular animal species . . . centaur . . .

David: Well, can I ask you a few questions?

Clifford: Sure.

David: Okay. Did it have five fingers, or . . .

Clifford: No, at that time I did not go into detail on that because he just showed it and said, "We'll go through this the next time."

And I respected him, and I said, "Okay, fine."

Corey: And there is the possibility of us being able to get x-rays done of it.

Clifford: He even volunteered to have somebody look at these things, because he's the last of the persons at First Mesa. And he wants it to be known that "I have this information".

So he sort of like asked me, in a way, "What shall I do?" And I said, "Well, I think we ought to

document it.”

And one of them goes through the scientific analysis of these things, because this is far too important for just to let it go.

David: I assume that it has a human-like head with eyes, nose, mouth, or . . .

Clifford: Well, it's got the features of things that humans are made with: eyes, legs, hands.

David: But the proportions are all different?

Clifford: Proportions are different. And it might have been just one of the smaller species . . . because there are many species. In our teachings, there were different sizes.

Even in the ant people, there's different sizes. In the insectoid world, there's different sizes. So it could be one of the same species but a different type.

David: Wow!

Corey: Does he have the history of how it was found, . . .

Clifford: Yes.

Corey: . . . where it was found?

Clifford: He's got the whole history.

Corey: Excellent.

Clifford: And he also has detailed information of how he got that, when it happened, the dates and so on. So he's very thorough in that.

Mr. Malava, that's his Hopi name, and he has a lot of information. And he's like the last of the priesthood of the First Mesa Hopi.

They're all different. But he has made himself the spokesperson for what is left with him throughout the ages from previous grandfathers and the group that he got his teachings from.

And he feels that now is the time to let the public know, primarily for two reasons.

First reason is that he wants to set the record straight about these other writers that have been telling a whole bunch of hoaxes about the Hopi and get the record straight.

And the other one is for the longevity of the information for the future generations. Even though it looks like we're at the end of this fourth world, he wants to transfer that information on to the next generation so that they'll have an idea of what history is involved with the Hopi people.

He's got so many information, including not only about the mummified things that he talked about, the flying shield, but also about the asteroids and how it happened in the past and what might happen in the future.

And he's at the stage in his life that he wants to pass on this information to the general public. And nobody . . . He tried to get somebody to carry on his duties and function of what he is in First Mesa. And he's not getting anybody to work with him to be his protégé.

And so what he wants to do is that he wants to record this and pass it on, anywhere from the simple ones to the storytelling-type approach to advanced things like what we're talking about.

Corey: Can you explain a little bit about the Hopi prophecies of the first, second, third, fourth world, and why we're in the fourth?

Clifford: Well, the first three were destroyed by things of nature, you know, like earth, wind, fire, earthquakes. And the last one was, of course, the flooding.

And so this is why we, as Pueblo people, survived in the Grand Canyon, and we've become sort of like the wards of the different insectoid people. This is what our history tells us. It's not something that was made up. It was not somebody who came from somewhere and gave us this information. It's part of our history and it's our system.

Corey: How does the insect people tie into the fourth world and third world?

Clifford: The way they describe it, I think that they were not only from the inner world, but I believe that they also, according to the teachings, they were from other off-world systems that they saw, which would fall in the same category as the Guardians and the Keepers of our Earth that saw this catastrophe.

And there was a reason for a lot of these clearances, so to speak.

You've got to clear the Earth of the bad things. And I think the same theory applies with the dinosaurs or the giants that to get rid of those things.

And whoever's in charge, whether you call it God or the Great Spirit or whatever, is the one that took it upon themselves to say that "we've gone too far on this end or we made a mistake, so let's clean this up again."

Or that "humankind did not follow what we told them to do and they deviated, so we got to destroy that planet that they also created a mess on there."

And I think that this repeats; history repeats itself.

Corey: Yeah.

Clifford: So now we're in . . . What the Hopis, the Zuni and other Pueblo people say that we're now in the end of the fourth world.

David: Does every world, as described, end in a catastrophe of some kind – these cleansings you're talking about?

Clifford: According to the history that I have been studying, they had given them the opportunities not to get to that point, but they went and they exceeded what they were told not to do. So that was the last resort that says, "Well, if you do not follow what we had taught you to do, and you're violating that, we have no choice."

Corey: When the ant people realized that you were at the end of the third world, where did they take the Zuni, for how long, and what was life like where they went?

Clifford: Well, according to the teachings, we were in the fourth underworld. And they progressed each step from the fourth world, which was “a dark world”.

And then every layer that they went through becomes a lot cleaner and more lighter than the previous ones.

And there's many, many stories about how they got to the next world. The Hopis used the reed to go up on that. The Zunis, they talk about growing a certain tree, and I think these are just allegories that they had to make a reference to it.

And so they stepped up to the next world, and they stayed there for a while. And then eventually we came into what we call “the light world”.

And they use the allegory as the Sun Father creating that, which is true to a certain extent, because of the light and what we know about the Sun's energy nowadays.

So there's a lot of things that are mixed in there that is . . . you look at it from the science standpoint, which is true from the quantum physics standpoint, and then you also look at it from the spirituality standpoint, and you put those together and they fit perfectly of what the interpretation of the Indian talk about and what modern physics will tell you about.

And they talk about the same thing from a different language and a different concept.

Corey: Were the Zuni and Hopi brought below the Earth for generations?

Clifford: Oh, this is thousands of years.

Corey: Thousands of years.

Clifford: At least, yeah.

Corey: And when you emerged, do you know where your people emerged from and where you went next?

Clifford: Well, they said that the Grand Canyon . . .

Corey: Grand Canyon.

Clifford: And there's several places. The confluence of the Little Colorado comes from the east. And the Big Colorado . . . there's a travertine dome. They call it "The Sipapu".

All Indians have a reference to a "Sipapu" or a "Sipapulima". And that's where they came out from other parts of the universe, that they have to have a portal that they go through, where nowadays we can call it a wormhole or a vortex.

Corey: Wow! So when the Zuni were brought underground, they may have been brought to another planet through a portal.

Clifford: Uh-huh. I think that if you really look at it from the standpoint of science, I think that they were actually transported not only into the inner world, but the other beings came from the off-world. They came through those, what we call, again, wormholes or vortices out there. And they came directly through there.

There used to be an expedition, especially from my Zuni tribe, that . . . they recruited at least 20 people every year. They would bring them down into the Grand Canyon, and they had like a 10-day boat trip, and they identified all their sacred places, the Indians not knowing that they were looking for these vortices, and they actually showed them.

Corey: The Grand Canyon has a lot of other mysteries. Back in the late 1800s, there was a discovery that some of the artifacts looked possibly Egyptian.

Clifford: Uh-huh.

Corey: Do you have some information about that?

Clifford: Well, we actually did a documentary, I think four years ago. ["Expedition to Sipapu"] And our purpose was to go out there and look for the 1980 expedition that was financed by the Smithsonian through a guy by the name of Kincaid.



Expedition to Sipapu

EXPLORATIONS IN GRAND CANYON

Mysteries of Immense Rich
Cavern Being Brought
to Light.

JORDAN IS ENTHUSED

Remarkable Finds Indicate
Ancient People Migrated
From Orient.

The latest news of the progress of the explorations of what is now regarded by scientists as not only the oldest archaeological discovery in the United States, but one of the most valuable in the world, which was reported some time ago in the Gazette, was brought to the city yesterday by G. K. Kinkaid, the explorer who found

fect ventilation of the cavern, the steady draught that blows through, indicates that it has another outlet to the surface.

Mr. Kinkaid's Report.

Mr. Kinkaid was the first white child born in Idaho and has been an explorer and hunter all his life, thirty years having been in the service of the Smithsonian Institute. Even briefly recounted, his history sounds fabulous, almost grotesque.

"First, I would impress that the cavern is nearly inaccessible. The entrance is 1200 feet down the sheer canyon wall. It is located on government land and no visitor will be allowed there under penalty of trespass. The scientists wish to work unobscured, without fear of the archeological discoveries being disturbed by curio or relic hunters. A trip there would be fruitless, and the visitor would be sent on his way. The story of how I found the cavern has been related, but in a paragraph: I was journeying down the Colorado river in a boat, alone, looking for mineral. Some forty-two miles up the river from the El Tovar Crystal canyon I saw on the east wall, signs in the sedimentary formation about 2000 feet above the river bed. There was no trail to this point, but I finally reached it with great difficulty. Above a shelf which led it from view from the river, was the mouth of the cave. There are signs leading from this entrance some thirty yards to what was, at the time the cavern was inhabited, the head of the river. When I saw the signs on the wall inside the entrance I became interested, secured my gun and went in. During that trip I was here several hundred feet along the main passage, till I came to the spot in which I discovered the minerals. One of these I staked up and photographed by flashlight. I gathered a number of relics, which I carried down the Colorado to Yuma,

And he actually went into the cave, and we were up there to look for that place. And while we were there, there was some drilling that was going on. We did not know that until we got there.

And the purpose of us going over there was to find out about the cave where they had Egyptian and Buddhist statues that were removed by the Kincaid expedition and transported to the Smithsonian in Washington, DC.

We inquired about that by official means, and we were told that they had dumped that into the ocean, gold statues.

David: Yeah.

Corey: We had heard about bones of giants, bodies of giants, being dumped in the ocean by the Smithsonian in the past.

Clifford: Yeah. But that expedition is on YouTube. It's called "Expedition to Sipapu". It's all factual. We went through the archives.

Corey: But you don't recall any specific stories about people living there from different lands?

Clifford: Well, you know, you have to really listen to the story and you have to really understand the language of what they mean.

When they say that they go through . . . Remember, I said that they went through layers.

Corey: Yes.

Clifford: So they had to be way down in there. And that's . . . And we have a cyclic life. We all go back into where we were at, which is the Inner Earth.

And the Inner Earth has been visited by OBE, you know, out-of-body experiences. And I know a lot of people that have been there, and they were sad to come back here because it is so beautiful out there. I know they're not lying. They can't lie to me.

David: Right.

Corey: I've had a little bit of experience with that myself.

Clifford: Yeah, it is beautiful, they say. “I didn't want to come back,” they say.

Corey: I believe in your testimony, you've mentioned a different type of insectoid as well.

Clifford: Those are the praying mantis type?

Corey: Yes. A lot of people in this audience will be familiar with the mantis-type insectoids.

Clifford: Yes. I think that there were other species, and not only the ones that basically are on the ground, or inside the ground like the ants, in the insectoid species, but there were also other species that were also teachers.

Corey: I heard something mentioned which I found interesting in the smart-glass pads about Native Americans that reported a group called the Two Hearts.

Clifford: Uh-huh.

Corey: And I found that interesting because the Reptilians have a primary and a secondary heart. Do you think these are the same beings?

Clifford: According to the Zuni mythology or stories, is that all the people that were made were all good people. But there was a two-hearted people, which we now call them as the “Dark Force people”, or to the more blatant term is called the “witchcraft people”.

Those are the ones that are referred to as the “two-hearted people”, because they do not have the same mission as a regular human being. Their mission is to be the Dark Force for the balance.

Corey: Ah, yeah.

Clifford: And the balance was to be population control. But they overstepped that control and they became more powerful, and that's what we're going through right now. We're in an imbalance of the Dark Force. But it's going to be straightened out.

David: One of the things, **Clifford**, in terms of research that I think is very compelling, is you look at these skulls that were originally found in South Africa, the Boskop skulls, and they are elongated.

Clifford: Uh-huh.

David: The brain is about twice the size of a normal brain. This is not the result of head binding. We find them in Siberia. We find them in South Africa. The Egyptian depictions of the pharaohs have this characteristic.

We've now found them in tombs in Europe. And it does appear that some of the classic Mayan inscriptions show people with elongated skulls as well.

So I'm wondering if you have any information on that.

Clifford: The theory that I have looked at is what in the beginning, in order to have a leadership to carry on the functions of the "new human", is that they had to have a hybrid program. And those people, at that time, were still in the stages of becoming advanced humans. And I'm talking about the indigenous people.

So they had to have a transition. And I believe that, based upon the prayers and the rituals, and it's just the historical facts, based upon a comprehensive study about these things, and you look at that, and these were a special type of people. And they had different features than the regular group.

So even in the Zuni history, the priesthood were sort of like half whatever off-world means, but at the same time they were half humanoid-type people.

So they started that blue line, so to speak - bluebloods organizations. And it was done by a certain group, by a clan system, or by an order of what you might call a societal system. There's many societies in many different pueblos.

They got the medicine society, kachina society, the priesthood society from all directions and all different . . . And each one has certain functions.

David: Clifford, what do you think about casinos being built on American Indian land?

Clifford: Indian reservations are where the casinos are at. And they had access to them all these years, but I believe that there are a lot of activities, construction activities, going on on the Indian reservations because that's land that nobody can go in. It's just like a national park, same status, or a military base, same status.

So they can carry on anything that they want. And casinos are to get people away from their usual activities and take away all their money, number one. And then also to give them another deviation, because they've already got alcoholism.

They've already got domestic violence, drugs and everything else.

Corey: Throw in some gambling in there.

Clifford: So this is another one. Gambling is . . . You can do it even sober. So I believe that's also another deviation.

David: Do you think that each of these sacred lands for the American Indians have underground areas beneath them, that maybe these casinos are built there so that they have a nice cover to access those underground areas?

Clifford: Yeah, especially, for example, like at Jicarilla Apache, Dulce [New Mexico]. I think there's two casinos over there. The stories and the legends, or to a lot of times, mythology, about some of those places, that the underground people used to occupy – they still do to this day – they used to go into those mountains by pilgrimages by different tribes.

That's where they used to have the contact directly with them. But as time went on, they started putting in fences; they started isolating it. So we no longer . . .

Corey: . . . have access.

Clifford: . . . have access.

Corey: So this is the military that has this place locked down?

Clifford: Nobody really knows who.

Corey: Okay.

Clifford: But I could never get information from those people because . . . I think what they did was they signed a document, "If anybody asks you this, you don't tell them."

Corey: Nondisclosure.

Clifford: So they said, “Well” And they got paid real good money.

David: All right. Well, **Clifford**, this has been really great, and I'm so grateful that you wanted to come forward and share all your knowledge with us.

And **Corey**, do you have anything you'd like to say to him in closing?

Corey: Yeah. It's been an honor to have you and your information out here. I'm very happy that this can be a conduit to correct a lot of misconceptions about the Hopi and Zuni people.

Clifford: I'm glad to be here.

David: Well, thank you, **Clifford**. And I want to thank you for watching. This is “[Cosmic Disclosure](#)” with **Corey Goode**, myself, [David Wilcock](#), and our special guest, **Clifford** Mahooty.

[Cosmic Disclosure: Alchemy and The Law of One](#)

Season 8, Episode 11

[David Wilcock](#): All right. Welcome back to “[Cosmic Disclosure](#)”. I'm your host, **[David Wilcock](#)**. I'm here with **Corey Goode**. And in this episode, we're going to get into the mysteries of alchemy and The Law of One.

So, **Corey**, welcome back to the show.

Corey Goode: Thank you.

David: The alchemical tradition is a very interesting thing. The word “alchemy” is apparently derived from “Al Kemet”, or the “science of Egypt”. And a lot of people have speculated that this idea of lead transmuting into gold, although there may be a practice that does that, that it is somehow analogous to the transformation of the soul, the idea of the Ascension, the lightbody, that the physical body is like the lead and that the lightbody is like the gold.

Did you encounter any information when you were in the Secret Space Program regarding this idea of the alchemical transmutation?

Corey: I didn't see information directly about alchemy, or if I did, it wasn't what I paid attention to. But the more I'm learning about alchemy, the more I'm finding out how it does have to do with the Ascension process.

David: So did you ever encounter information suggesting that metals could possibly transmute, as the alchemist claimed to have accomplished?

Corey: Yes, actually. When they were building the Alien Reproduction Vehicles, building their models based on that craft that was given to us, I believe by the Nazis, they found out that the middle column inside the flying saucer had mercury in it, or some sort of gallium metal, that was spun in different directions in different tubes within tubes, and a high electrical field was applied to it.

(Embedded video)





This was a part of the process of electrogravitics.

When we were trying to repeat that process, we were using just regular mercury. When the high electrical fields were applied to the mercury, it actually turned into gold. It looked like kind of a coral. The told turned into like a coral.

David: And this was chemically tested – confirmed to be gold, not just gold-like?

Corey: Yes. And they've reproduced this at a university, but they took small amounts of mercury, applied heavy, heavy electromagnetic fields to it, and it turned to gold.

David: Really? Well another interesting angle here is when we get into the science of vortex points on Earth – ley lines, things like this – I have more than one insider who told me that alchemical transmutation, to get this to work properly in a natural location on Earth, you have to be at one of these special node points. There's something about the physics there that makes this more apt to happen.

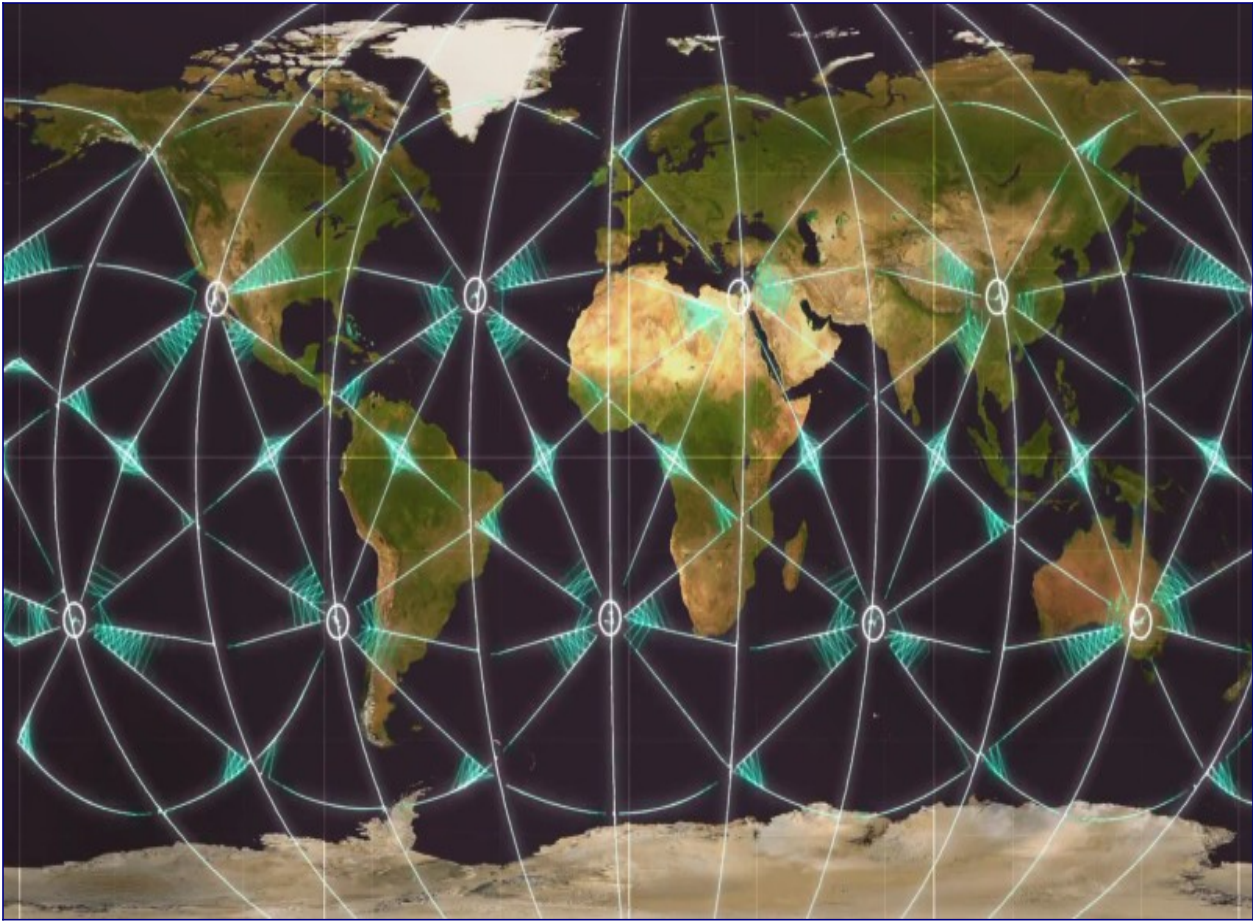

Corey: Well, those node points are entrances and exits to, basically, portals. These node points that . . . We've talked about how the Earth has a grid around it, and each of these node points has a certain aspect that has to do with maybe the stone, the crystalline stone, . . .

David: Right.

Corey: . . . and it causes an electrical connection between the cosmic web and the node. And at different points as the Earth is spinning, and depending on where it is with the Sun, that electrical connection takes a path of least resistance.

And whichever node happens to be in that path of least resistance, that is where a portal would open.

David: Hmm. So it is conceivable then that ancient people could have determined that, with the knowledge of the grid and the knowledge that certain planetary alignments would activate these portals, that at certain times you could get this to work.

Corey: Sounds like it. There's obviously a lot of high electromagnetics involved with portals, so maybe they have multiple purposes for those locations.

David: Right. Did you ever hear anybody describe this idea of the alchemical process? Was there anybody in your Secret Space Program that was really big on secret societies and this idea that the body is like the lead that needs to be consumed, transformed?

Corey: Yes. A lot of the engineers and scientists that I worked with were heavily into that.

David: Really?

Corey: They would talk about all of these different things, but it was not in my interest. I focused more on other things. And, obviously, the things that I remember are the things that I was looking into the most.

These secret societies know the mystery teachings. And I believe that in these mystery teachings is a more detailed chronology of what has really occurred on this planet over the last couple cycles.

David: Do you think that some of the texts that have been sequestered into the Vatican library, allegedly from Egyptian Library of Alexandria, might have information about this in them?

Corey: Yes, definitely. The Library of Alexandria was listed in the glass pads as basically a false flag. All of the information was taken out and taken to the Vatican.

And within many different manuscripts from different parts of the world, you have information that points you towards a solar flash or a solar event of some sort.

David: So despite how much has survived that I've talked about in Wisdom Teachings, about the solar flash and so many religions and ancient spiritual teachings, there could be much more about it that we lost that's hiding in the Vatican library.

Corey: I'm sure that in more than just that one location, there are greater details about what occurs during the process.

David: All right. Well, now what I want to do is take us through some Law of One quotes on what they call "harvest".

And the word “harvest” is how The Law of One usually describes this process.

As I've said, in other episodes, “Wisdom Teachings”, etc., don't get hung up on that, because it appears that “harvest” is referring to a Bible quote in the Book of Matthew, where it says that “the wicked ones will be plucked one by one from the just at the end of the age.” So they use . . .

Corey: And thrown into the fire.

David: Yeah, this harvest metaphor. So what I want to do is read you some of this stuff that The Law of One says, because we've had a lot of people asking for clarification. The Law of One is very puzzling.

And first of all, **Corey**, just to set this up in case people haven't seen the other episodes, what have the beings that you're talking to said about The Law of One and their relationship to it?

Corey: They said that they were responsible for delivering that information.

David: And this is the Blue Avians?

Corey: The Blue Avians, yes. When I asked them about it, . . . Yes, they said that they brought that to us as a guide for a consciousness expansion.

David: And you also said, I believe, that once you started reading it, their verbiage changed.

Corey: Yes. They were always very, I guess, cryptic with me to begin with. But they basically use what language you have, what words you have already that you use on a regular basis, words from your lexicon.

David: Right.

Corey: They're going to use those in communication with you. And when I was able to finally read The Law of One, that gave them a whole new vocabulary to use with me. It broadened the communications quite a bit, and I was able to understand more of what they were saying.

David: So just to be absolutely clear, they started to sound like The Law of One after you read The Law of One?

Corey: They started speaking, yes, in that same manner.

David: Interesting. And does that continue to happen now?

Corey: Yes. And they spoke in a similar manner before – the cadence, the way the information was delivered – but they were using all of the language from my current perspective.

David: Now, what has their opinion been of the quality of what was done in the original Law of One work? Do they say that it's accurate? Did they say that there were any mistakes in it?

Corey: No, they said that it was accurate, that it did come through the distortions of the people recording it, delivering six higher-density information through a lower-density filter. There's always going to be that type of thing, that they did not plan for people to use it as scripture like a Bible, like some have done, that they do not want any new religions to develop, that we need to focus on inwardly instead of developing all these religions.

David: So one of the things that I'm sure you're familiar with by now off all the people writing in, you don't just read The Law of One to figure out what's going to happen. There's a lot of cryptic statements that need to be deciphered.

So as a service to the audience, I want to go through what they actually say and have us discuss it with the knowledge that you now have, which has given a lot more clarity in some ways to some of the things that were in The Law of One.

So let's take a look now. At this point, Don Elkins had just gotten this new contact. He wants to know about planetary changes. He wants to know about catastrophes. He's expecting there to be some kind of event. Look at what happens.

THE EARTH CHANGES

**1.9 Questioner: Can you say anything about the coming planetary changes?*

David: Look at their answer.

**Ra: . . . The changes are very, very trivial.*

So they don't want to answer the question.

And then, look at what happens next.

**We do not concern ourselves with the conditions which bring about the harvest.*

David: So isn't that interesting? They don't want to answer the question. They think it's trivial.

So why do you think they would be so disinterested in talking about this particular subject, based on your own experience with them?

Corey: They're very careful about how – when they deliver the information – how we're going to react to it, and also how we might possibly report the information through our distortions.

So they're most likely seeing things probably three, four or five steps down the process of giving that information, since they view time differently. So they're looking at things on a different level.

We see things just like you and me, with linear time occurring. When they're watching, they're seeing what has occurred, what is going to occur, what things are happening currently. I mean, with what's going on, they extrapolate what is going to happen. They see all of that at once.

And they're communicating with you in that . . . Time is real weird for them to try to communicate with us.

David: Why do you think they always call us a “mind/body/spirit complex” instead of a word like “person”?

Corey: Well, they don't want us to focus on ego. They want us to focus on oneness, that we're a part of a . . . more of a collective instead of the one single ego that's fighting or in competition with every other ego.

David: So if the word “body” is only one of these four words that they use to describe us, do you think that their view of us, where we would see ourselves as a body and as a separate person, that they have a different view of us than that?

Corey: Yes. They see us . . . They see all three of those when they see us. Just like they see with the time occurring with us, they see us on all levels.

And they're also, as I've reported recently, communicating with us on a higher self level more than anything.

David: Right.

Corey: Most of it is occurring on the higher self. The higher self decides what the ego is ready to handle; how the information should be delivered to the ego. And the positive beings and higher-density beings communicate with you on that level.

David: So there could be whole levels of what we are that we don't normally have hardly any access to at all. Are they trying, in some way, to help us gain more access to those parts of ourselves?

Corey: They're trying to help us reintegrate all those different parts.

David: Okay.

Corey: Yes.

David: All right, so the next set of quotes is very important, because as you probably know, **Corey**, I lived with the people that did The Law of One for two years. And I'm one of the only people who ever got to do that.

And Carla revealed to me while I lived with her that they had censored some of the things that were said, and it never got into any of the first four books, nor did it get into the fifth book where they had allegedly all the things that they had taken out from the first four.

Only after Tobey Wheelock did something called the Re-Listening Project, where he went to the original tapes, listened to everything, and transcribed it exactly the way it was, did this quote come out, which Carla, for whatever reason, was very uncomfortable with this and didn't want it in there.

But this adds so much, so take a look at what it says, why might she not have wanted this in there.

THE SINKING OF LEMURIA

**10.15 Questioner: [1] was wondering about the advent of the civilization called Atlantis and Lemuria . . . ?*

**Ra: . . . The civilizations of Atlantis and Lemuria were not one but two.*

**Let us look first at the Mu entities.*

David: So before we get any further, how do you feel about that statement about Atlantis and Lemuria being different?

Corey: Absolutely. Yes, that's been known for quite a while in the programs.

David: And Lemuria is more a Pacific Ocean-based culture?

Corey: Yes, over close to Asia, I believe . . .

David: Right.

Corey: . . . was the information that I saw. And that's been information also in the public for some time.

David: Okay. So this is still pretty early, because they were doing a lot of sessions at once. So this is right at the beginning as this was happening.

**They were beings of a somewhat primitive nature, but those who had very advanced spiritual distortions.*

David: Now, have you ever encountered something like this in your own travels, beings that would be somewhat primitive but have very advanced spiritual abilities in some way?

Corey: Well, yeah. What seems to occur is that when a lot of these different beings become spiritually advanced, they back away from a lot of the, I guess, worldly things that . . . I guess it's what people in spiritual areas on our world right now, like in Tibet. They're more focused on raising their consciousness than they are building the next Ferrari.

David: So you might not need technology if you have very advanced spiritual ability.

Corey: Well, they have no use for it. They're focused on other things.

David: Right. So we have beings that are very advanced spiritually, somewhat primitive. And then it says:

**The civilization was part of this cycle, experienced early within the cycle at a time of approximately fifty-three thousand [53,000] of your years ago.*

David: Now, this date to me is interesting for a couple of reasons. What was one of the things that you talked about with a time period that's only a couple of thousand years off from 53,000 years ago?

Corey: Well, the Pre-Adamites came during that time period.

David: Exactly.

Corey: And some of the information that I've delivered also stated that there was some sort of a cataclysm cycle after they had arrived that they had to dig out from.

David: Right.

Corey: And then there was an additional one that occurred around 12,000 years ago.

David: So do you think it's possible that Lemuria would have been a separate culture that was still on Earth with very advanced spiritual function contemporaneously with when these Pre-Adamites had landed here?

Corey: Yes. The Pre-Adamites . . . There were several groups of humans, I guess you would call them on the Earth. The Earth was being used as a refugee zone for a while . . .

David: Right.

Corey: . . . over different periods of time. So people were being brought here for short periods of time or permanently.

David: Don't you think it's pretty amazing that this date is so close to what your space program people have gotten about when the Pre-Adamites showed up?

Corey: Yes. Yeah, it's definitely an interesting correlation. I'm not sure how the Lemurians and the Pre-Adamites would have interacted.

David: Well, they make some leading statements in The Law of One, that there were problems around this time that led to this catastrophe being necessary. They don't say what the problems were, but it's in there.

Corey: Okay.

David: And that's what's so amazing, because it's the 53,000 year time frame.

**It was an helpful and harmless place [Lemuria] which was washed beneath the ocean during a readjustment of your sphere's tectonic plates through no action of their own.*

David: Now, this was shocking to me, and it kind of explains why Carla might not have wanted it in there, because they're saying that they were helpful and harmless but that they actually sank through the Earth going through a massive change and that it was no fault of their own.

Corey: Right.

David: What do you think might have been the reason why that cataclysm needed to happen?

Corey: Well, what's been explained to me is that the Earth is going through this Ascension process, going through all of these different changes and processes. We are basically like fleas on a dog, and the dog's going through an Ascension, and we're being brought along with it.

And Lemuria, being inundated with water when they didn't seem to do anything to authorize that type of an event, I was told that in each cycle there are these types of cataclysmic events. It's kind of like growing pains that the Earth is going through. It's not the Earth trying to cleanse itself of us.

David: Right.

Corey: It's just going through a process. And as the Earth goes through the process again at the end of this age, then there are going to be similar things occurring – earthquakes, tsunamis, that kind of a thing. But it's not directed at human beings, trying to destroy human beings.

It's just the Earth is going through its own process, and we happen to be on it.

David: We're not necessarily just sitting ducks waiting to die when a tsunami comes. There could be some sort of a cosmic rescue plan.

Corey: Yes, and it's not necessarily going to be a global tsunami. It's going to be in a region . . . There are going to be different things happening in different regions.

David: Right. So these peaceful people in Lemuria didn't necessarily die in this flood. They might have been removed by benevolent beings so that they did not experience that.

Corey: And depending if they were that far advanced spiritually, they probably had remote viewing-type capabilities, and they may have been warned by their religious workers.

David: Right. So they could have actually evacuated the area first.

Corey: Right.

David: Okay. Next it says right after this:

**They set out those who survived and reached many places in what you call Russia, North America, and South America.*

**The Indians of whom you have come to feel some sympathy in your social complex distortions are the descendants of these entities.*

David: Isn't that interesting?

Corey: It is, especially when we go back again to the Hopi legends.

David: Okay.

Corey: They talk about their point of immersion in the Grand Canyon, that for they don't know how long – generations – that they were brought beneath the Earth by the Ant People . . .

David: Right.

Corey: . . . to survive a great cataclysm on the Earth. That ties in very well to their current prophecies and lore.

David: Well, and we also see, whether we're looking at Native Americans or whether we're looking at Asians, there are certain similarities in their features, . . .

Corey: Yeah.

David: . . . which has suggested . . . And, you know, the conventional explanation for that is this idea that there was originally a land bridge between Alaska and Russia, and that everybody that came into the Americas had to come over that land bridge.

Corey: Right. And I had a conversation recently with a Zuni elder, and we were talking about Hopi prophecy and that land bridge came up.

David: Really.

Corey: And he said, “No, we did not come here over the land bridge. We came here under, through a cave complex.”

David: Oh, wow!

Corey: “Under the ocean is how we got here. It wasn't a migration.” And their stories are full of migration stories – their history is.

David: So the really surprising thing is that this should appear in Book One, and it doesn't. And it's only in the last few years that it kind of very quietly emerged.

But once you see that quote, now you know that they're saying that there are some cataclysmic changes that occur at the end of the age.

But without it, you wouldn't really know that The Law of One was saying that. And if you only read the book, you don't get this. You have to go to the lawofone.info website. That's the only place you're going to read this.

Okay, not the quote goes on. And now this is in Session 21, Question 25. And this is going to have some really great stuff about the Pre-Adamites. You're going to love this, **Corey**.

**21.25 Questioner: Just to quickly refresh my mind – how many years ago did Lemuria suffer its catastrophe?*

**Ra: I am Ra. This was approximately fifty thousand [50,000] of your years ago.*

David: Exactly two 25,000-year cycles.

**The origins being approximately five three, fifty-three thousand [53,000] of your years ago.*

**The damage being completed in that last small cycle of the first master cycle.*

David: So isn't this interesting that they say there had to be a catastrophe, and that the origins of the catastrophe were approximately 53,000 years ago?

That is so close to the time that you and your people have calculated as when the Pre-Adamites crash-landed here.

Corey: Right. And the Pre-Adamites had crash-landed and were here for a little while when they had reported that there was another cataclysm that they had to survive and dig out from.

David: Hoagland's top insider had said that after the Pre-Adamites got here, that they had developed a very technologically advanced civilization in what we now call the Sahara Desert, and that if you go anywhere between 40 to 400 feet below the surface of the desert, that there's literally tons of remnants of their civilization down there, including very, very large statues.

Corey: Yes. That was definitely in the smart-glass pads. They sent out operatives to go and dig tunnels, just small tunnels down that weren't very obvious, and dig around in areas that they had observed through satellite imagery that they had developed.

And this was very similar to the deep penetrating remote imaging satellites that they've used to look in the Western United States for places to put installations in the mountains.

So, yes, they're able to see very deep into the ground. And things like that have been found. And that Sahara region, I had heard this information. I think I reported it on "[Cosmic Disclosure](#)" as well, and some of the statues were described looking a little bit African – some of them.

David: Right.

Corey: Yeah.

David: So one other thing that I find really interesting that I've done in my research to try to map out this catastrophe as something physical, is there is a major crater in America called Barringer Crater.



And this crater is normally thought to be the result of a meteor impact. But the really crazy part about it, two things:

Number 1, the crater is basically a square. If you look at it from the top, it's got the corners rounded off, which suggests some kind of geometric energy field – not anything that a meteor would do, because a meteor crater would be round.

And the second weird thing about Barringer Crater is that it has fulgurite under the sand. And fulgurite is fossilized lightning.

Corey: Hm!

David: So this, many scholars have concluded, is actually the result of a supervolcano that went off, and that it also, like in the electric universe model, had this electrical discharge to it that literally fossilized the sand and turned it into fossilized lightning as this big supervolcano eruption went off.

Corey: Right.

David: And the timing of this geologically is exactly 50,000 years ago.

Corey: Right. And in those big volcanic explosions, it produces plasma and electricity.

David: Oh!

Corey: Especially just in the dust from the ash, there can be an electrical charge.

David: And do you think it's possible, with the idea of the sacred geometry and all the stuff I've been talking about with grids on various planets, that you could have an explosion that takes place in that kind of a geometric way, and not just a round circle but actually a square like we see?

Corey: Yes. And also, I mean, have they dated when that possibly occurred?

David: 50,000 years ago.

Corey: I started to say, from what Tier-Eir had shown me, when the Earth is going through this transition, supervolcanoes do pop. The volcanism does increase. Earthquakes do increase. Storms become much more energetic.

So that's definitely in line with what occurs during the cycles, from what I've been told.

David: So we could have a supervolcano go off, and that type of cataclysm could also cause land in the Pacific to sink under the ocean at the same time.

Corey: Exactly.

David: How might those two things be interrelated?

Corey: Well, they may be symptoms of something larger occurring instead of playing off of each other.

If you have the crust starting to slip, it's going to cause volcanoes to explode.

David: Right. Could the solar flash do that? If it's on time – it's 50,000 years ago, right, so it's right when the solar cycle is supposed to end – could it do a supervolcano and a tsunami in the Pacific at the same time?

Corey: Oh, yeah. Some of the crustal displacement that occurs . . . You know, you don't just have plasma ejecting from the Sun. You have huge electromagnetic waves ejecting.

Those electromagnetic waves, when they get here, they interact with the electromagnetics of the Earth, and something has to give.

David: Right.

Corey: And you're going to have all of these crustal displacements, earthquakes from that, volcanoes exploding from the friction of it, storms becoming more and more energetic from the Earth spinning around in these cosmic energies like a dynamo, and all of the energy is going into the Earth.

David: I also want to close out our episode by hitting you with one last piece of really cool science data, and that is this: It's a known fact among archaeologists that if you look at human remains before 50,000 years ago, that we're not making any ceremonial religious type of objects; we're not making any really advanced tools.

Something happens 50,000 years ago, and they admit it – that it happens rather spontaneously worldwide 50,000 years ago. People start doing religious behavior. They start doing art. They start making more complex tools. They start making more complex clothing, more complex weapons.

Something big happens to everyone on Earth about 50,000 years ago.

Corey: The field of consciousness expanded. We suddenly had access to a whole new spectrum of consciousness.

When you go up in the densities, you're going up in consciousness, basically.

David: Right.

Corey: So they had a massive consciousness boost by what occurred with the solar flash, as well.

David: Well, that also implies that when the Pre-Adamites first got here before this happened, that it really could have been like Planet of the Apes, in a sense.

Corey: Very well.

David: The indigenous humans didn't even have the basic – any type of language, any type of religious behavior, any type of more advanced toolmaking. They really were quite primitive.

Corey: Well, they could have been in between cycles. It sounded like Lemuria and Atlantis. Atlantis could possibly be the Pre-Adamites. The Lemurians seemed to get pretty far developed spiritually.

David: Right. And all those records were lost.

Corey: Right.

David: The ones that we still have suggests that other people on Earth were very, very primitive.

Corey: Right.

David: Well, this is a fascinating discussion. I'm your host, [David Wilcock](#). This is “[Cosmic Disclosure](#)” with **Corey Goode**, going into the mysteries of alchemy and The Law of One. Thanks for watching.

[Cosmic Disclosure: Guide to Non-Terrestrial Beings](#)

Season 9, Episode 1

Corey Goode: Welcome back to “[Cosmic Disclosure](#)”. I'm **Corey Goode**, and today I will be your host.

Today, we're going to be talking more in depth than we ever have about the different ET beings I've encountered through my childhood, through the MILAB training and ending with the Secret Space Programs.

FIRST ENCOUNTER

My first experiences with non-terrestrials began when I was only five years old.

I felt the need to go outside. I don't know why. And when I went outside, there were three golden orbs that were just floating up in the sky.



And I started watching them intently, and I wasn't afraid.

All of a sudden, I started floating, and the next thing I knew, I was in a room. I just remember I started to lift off the ground, and I was in a room.

And in this room was a Nordic woman, and walking around were small Greys as well.

The Nordic woman guided me into a room with children that were playing. And the children . . . some of them were bald, and their eyes looked a little different, but they looked human, like maybe hybrids. And then there were a few regular humans like myself there.

I remember a brother, sister, that were red-headed, that were close to my age, that were there, and they were just kind of interacting and playing with the other children, the hybrid children.

At one point, the Nordic lady comes to us and hands us this little device.





And it's a puzzle – a 3D puzzle. It has squares coming up, circles coming out of it, and you're fitting all these shapes together.

And I was successful at it, at the puzzle, and when I was successful, the Nordic lady came over and guided me out of the room and took me into more of a control room.

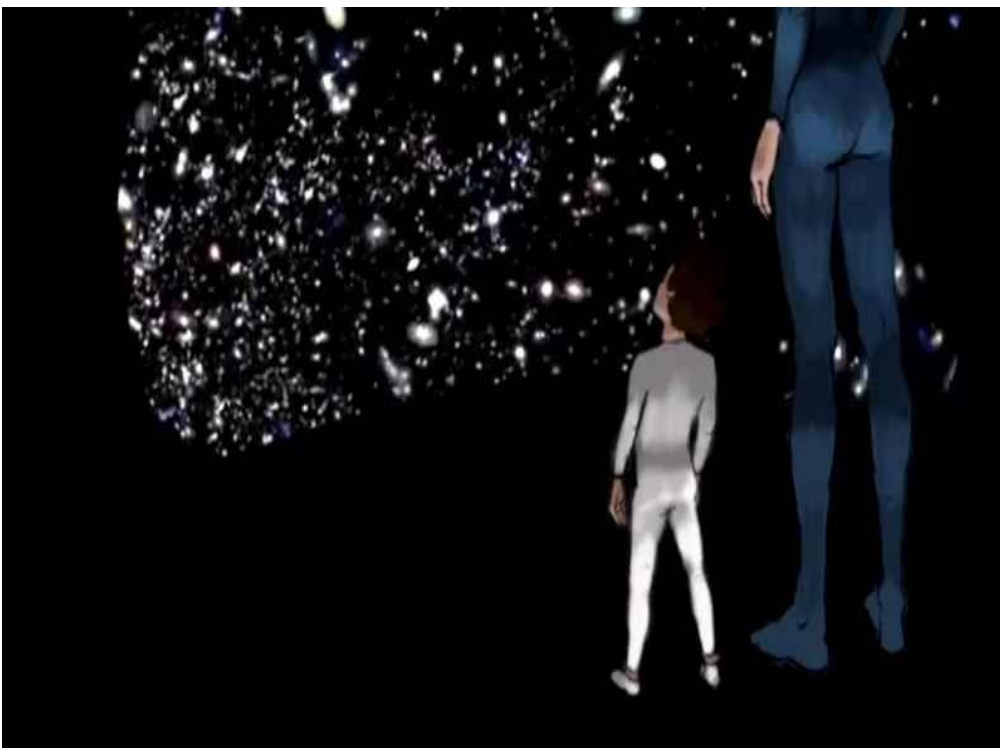
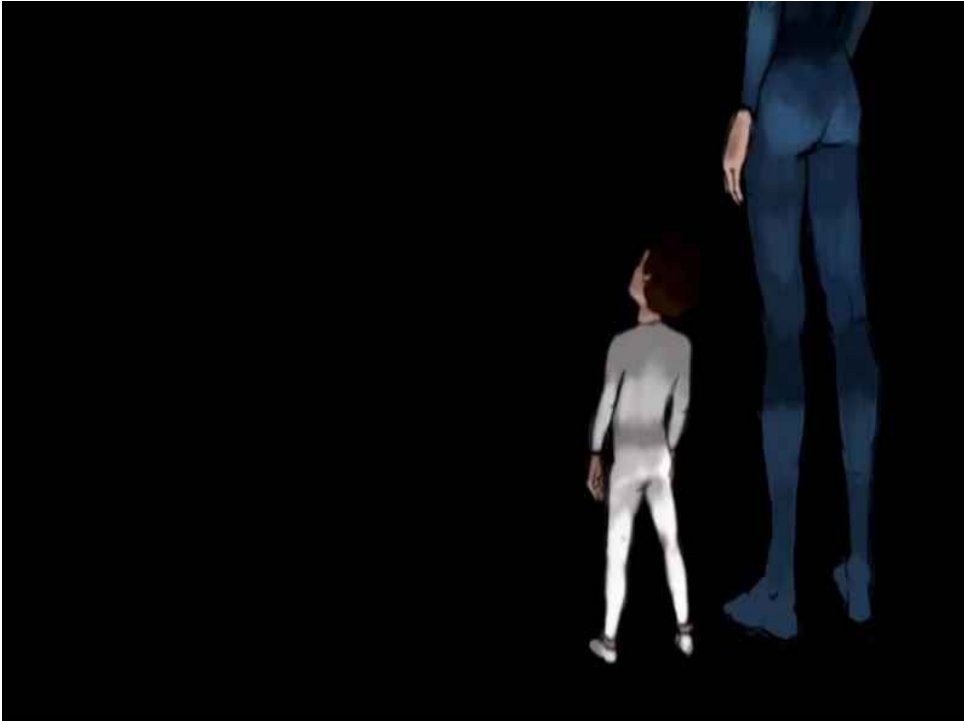

It was darker. I saw other Nordics sitting around control panels, amber lights reflecting off their face[s].

And this . . . kind of like a curved television mist appeared in front of me.

And then all of a sudden all of these star charts started popping up, and she would say, “Is this your home?”

And I would say, “No, my home is with my mom.”

And then she would go through another one. “Is this your home?”



And then she showed planets as well. And there was this very large planet that looks similar to Saturn that had a moon around it, and it was obviously inhabited.

And she pointed to it, and she said, “Is that your home?”

And I got a weird reaction, and I felt the need to . . . I started asking to go home. I said I wanted to go home. And they guided me out and took me home.

That was my first real experience that I recall with a non-terrestrial.

EXPERIENCES WITH PIRATE SHIPS

And then soon after that, I started having the pirate ships. I was five years old.

We were living with my grandparents, and I had had the same thing. I would have this, just need to go outside. And, you know, I was five years old. It was a bad neighborhood.

And I would walk out – I wouldn't be afraid – and I would see, off in the distance, a pirate ship, like a leaf on the wind, coming down closer and closer, going lower and lower.



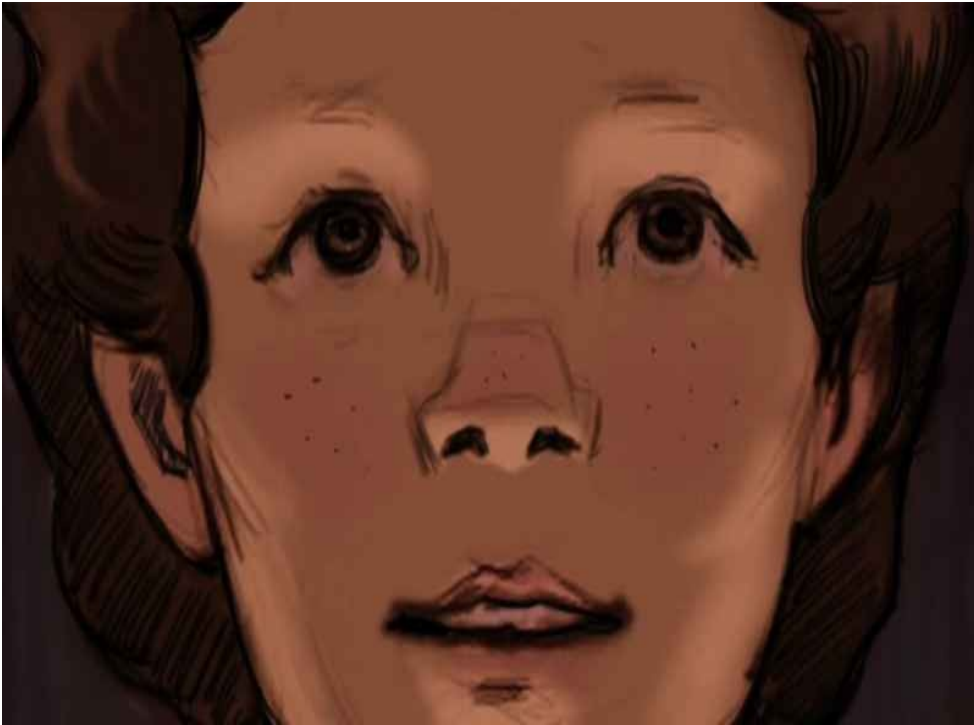

And when it would land on the ground, it would look like a solid . . . It looked like a ghostly ship, as it would slowly come down. It would look like a solid pirate ship.



I would then go onto the pirate ship, and then, all of a sudden, I was in a round room that had a window that went 360°, all the way around.

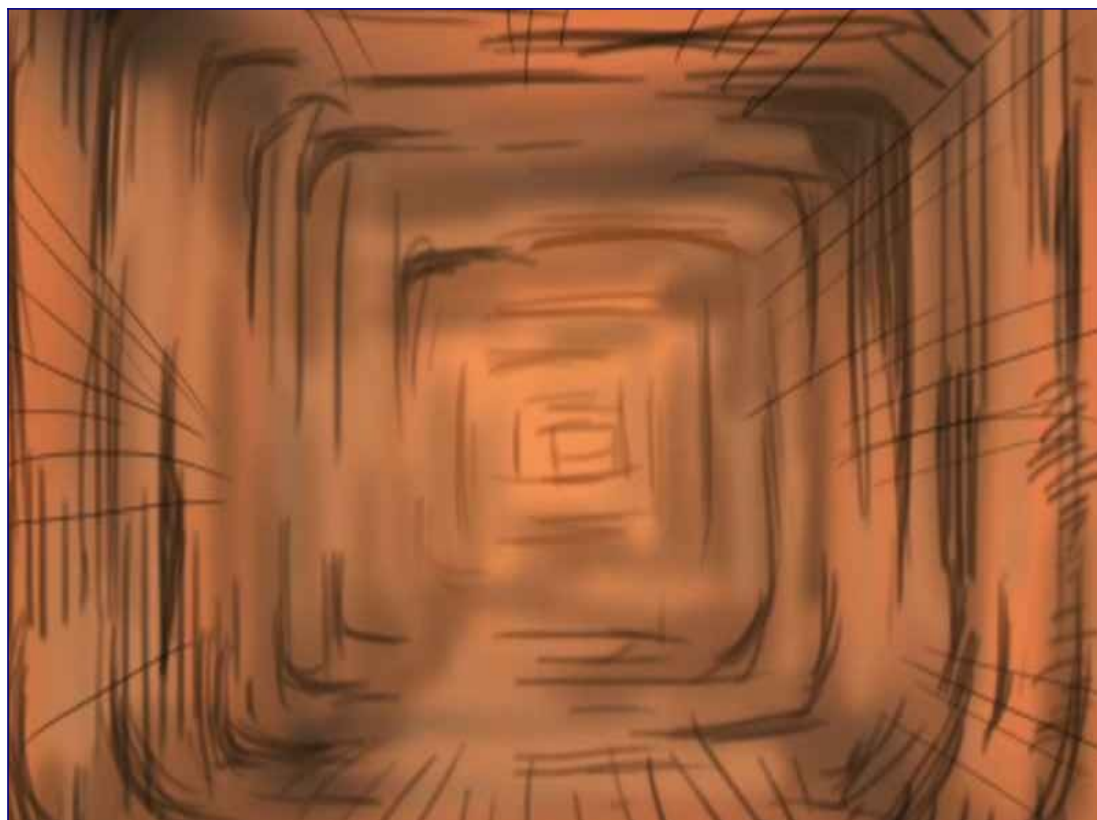

And when I stood up and looked out that window, I saw my apartment. I saw my entire city.

And then it took off the same way it landed, like a leaf, and I was brought to a cavern area to where they flew down into caverns.

And then they were in the smooth caverns, like they had been mechanically flattened out. On the walls and the ground and the ceilings, there were numbers, like you would see on the side of a ship or on a landing pad.



As we went through, we landed in this one area, and I got off, and it was now a flying saucer. And then I walked through the cavern area. I was not being pointed. They weren't pointing me to go any direction, but I was just walking autonomously.

And I'm looking around, and I see all of these other people of all ages and all colors standing in line, taking off their clothes, and putting them on card tables, military card tables.

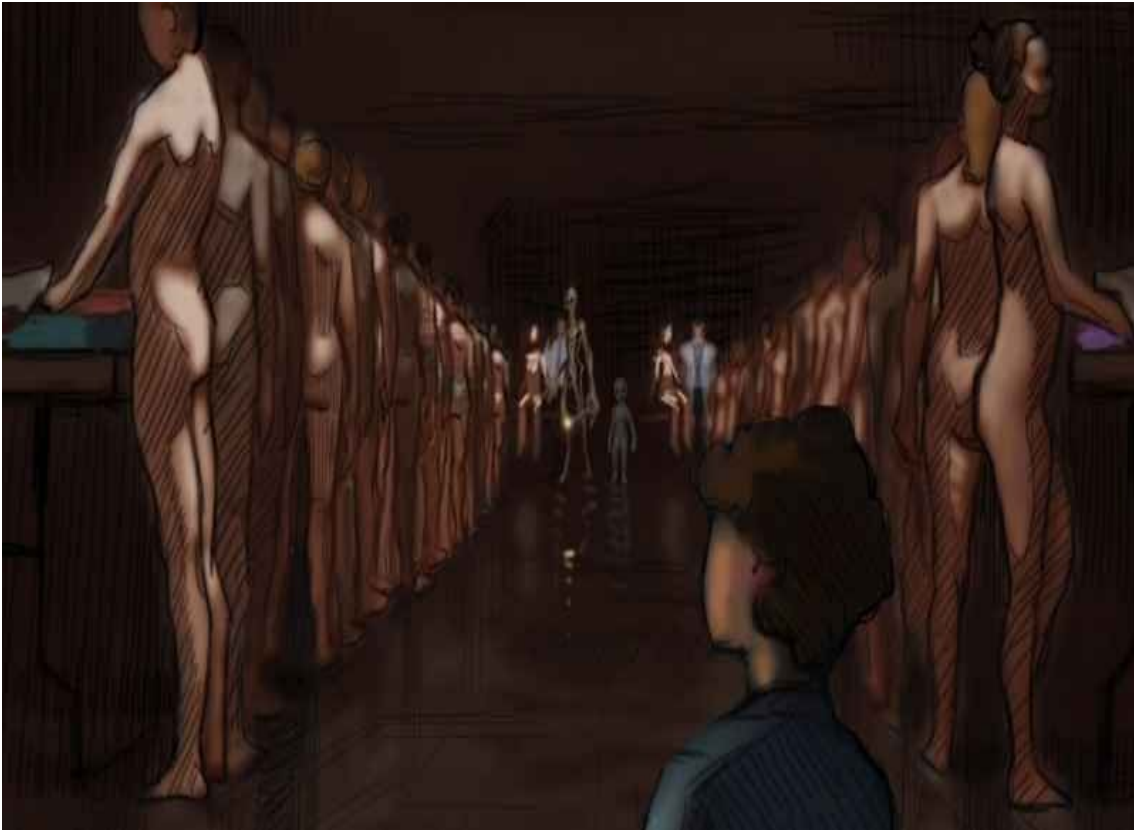

These people then were standing in line, a line that . . . There were surgeon lights that were there, that were pointed down onto a table.

And they would all lay on the table with no clothes on, and on one side would be this very tall Grey being and two little Greys. And on the other side would be doctors, human doctors in lab coats.

And they were doing joint examinations or procedures.

I don't have any memory of these procedures being done on me.

The next thing I would remember would be coming back into consciousness or awareness on the craft again in that same circular room. And then I would see myself floating down to my house.

And then I would see a pirate ship leave.

So those were my really, first encounters with non-terrestrials.

STARTING MILAB TRAINING



When I was about seven years old, in 1977, I was brought into the MILAB programs.

I recently saw some documentation from Sigmund, which is a pseudonym of an Air Force official who was giving me information at one point, that stated that I was an asset between 1977 and 1997.

So apparently the real MILAB training started in when I was seven years old.

Because I was identified as an intuitive empath, I was a perfect tool for them. They began to form me.

I started having weird experiences in MILAB training, to where I would be brought into a room to have holographic training.

I would walk in. I would see several Air Force people sitting at a card table, maybe some people in

some white coats. I would sit in the chair.

I would go through the procedure, but when I would come out, all of a sudden there would be a Grey alien sitting at the table. And they slowly started to acclimate me that way.

And what they were attempting to do was take my intuitive empath skills and train me to interface with non-terrestrials.

And that training was from the age of seven years old all the way up until I was 16 years old – right before I went into the Secret Space Program.



FIRST EXPERIENCE AS AN INTUITIVE EMPATH

My first real experience with being an intuitive empath in one of those real-world situations was when I was 13 years old.



I was taken off-planet to a small space station that is just outside the orbit of Jupiter.

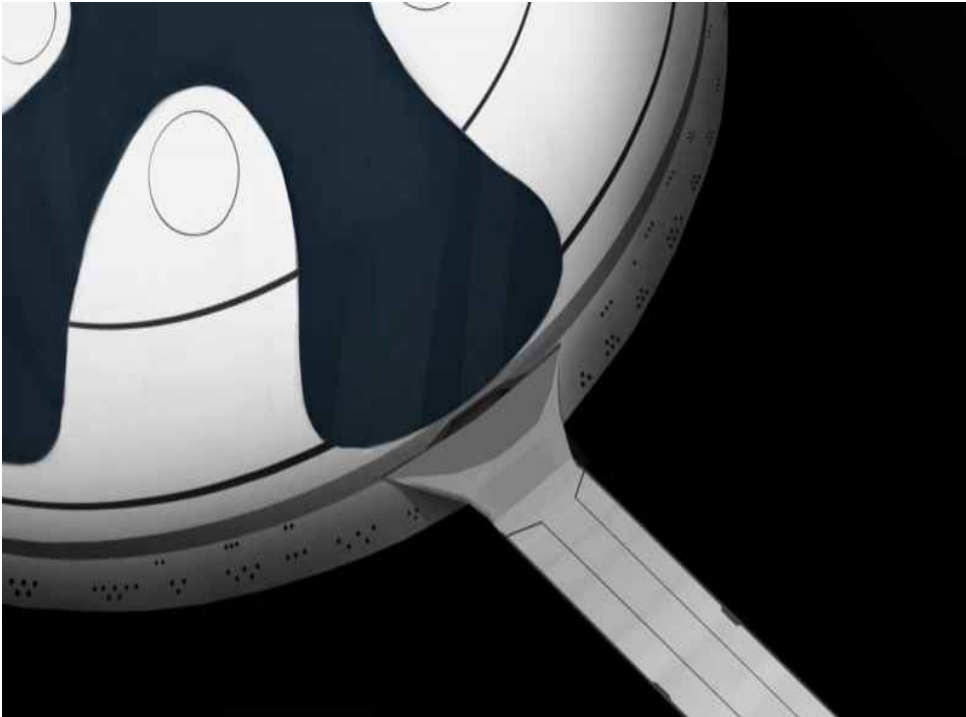

It was a temporal anomaly that you couldn't see with the naked eye. And you had to enter it and exit in the same way. They called it “punching in and punching out” from the same coordinates.

And it was a temporal anomaly, and when we flew into it, it was pitch-black. There were no stars.

All you could see were other craft flying to this space station.

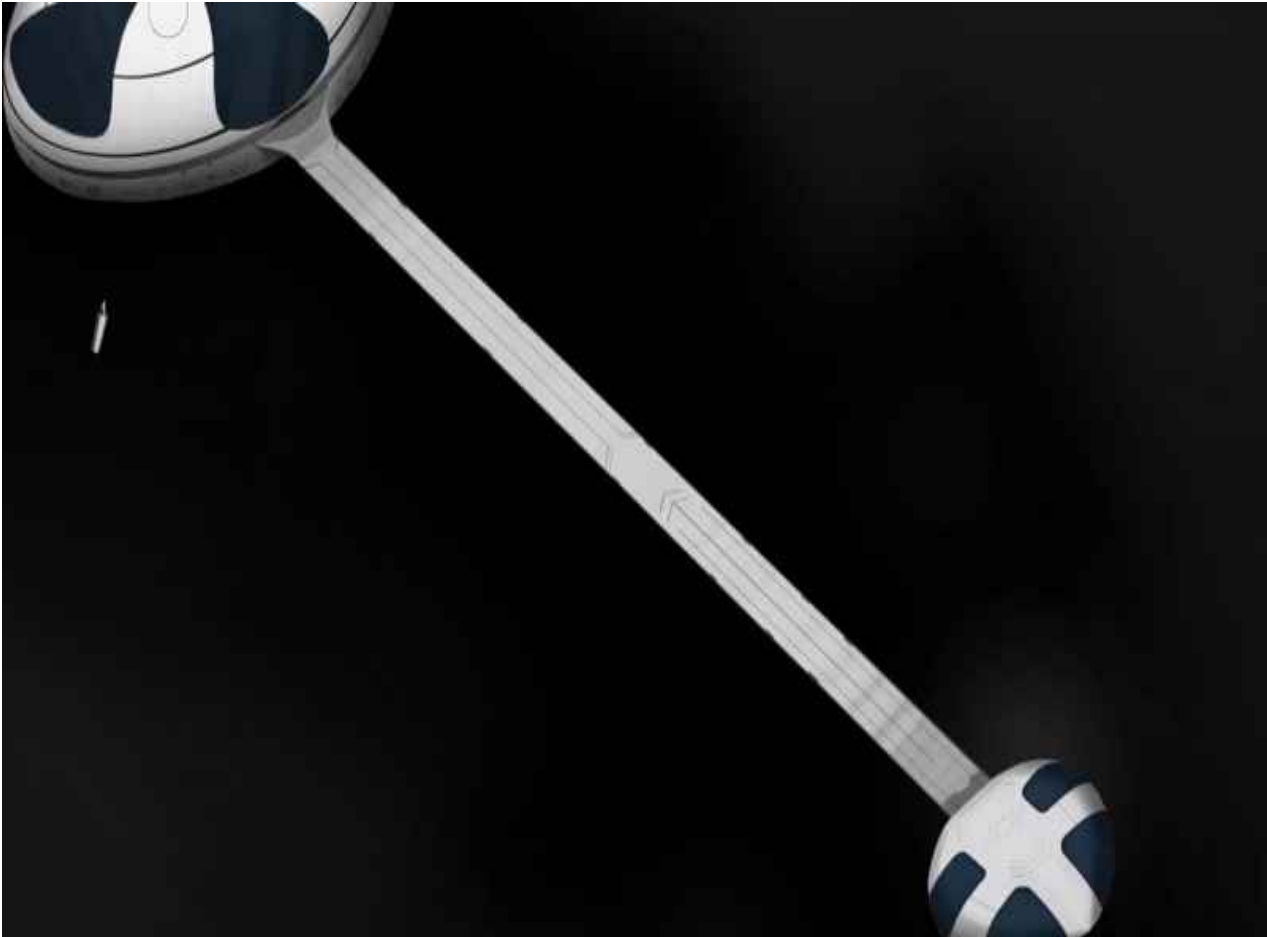

One end of it looked like a clam shell, and the other end was a big disk. And inside that disk was a giant UN-type meeting hall.

And I was brought into that meeting hall to be one of three intuitive empath support.

They usually had two other children or young adolescents with me, and they needed three to triangulate any type of deception or fear or anything that the primary person in the meeting needed to be aware of.

And there was a representative from Earth that was given a seat in this council meeting.

There were about 60 different beings that were already milling around inside that room, and some sitting down.

So I remember walking into that room. And first of all, I'm 13 years old. All of these beings, or a good deal of them, were taller than a normal human. So to me, a normal adult already looked very large.

And for the most part, I was trying to scan and look at these different beings to try to get some sort of an energy from them. And they were pretty much ignoring me. They could care less about me or interfacing with me at all.

A lot of them didn't look like they wanted to really interface with each other. I don't think it was a real friendly gathering. A lot of the times these people were at odds with each other because of this [these] 22 different genetic programs that are competing but are overall managed by this committee.

This was the first time that I saw a large number of different types of non-terrestrials at the same place.

Later on, I was brought into these meetings a couple other times. I've been to a total of three of them.

And for the most part, when I went to the last two meetings when I was an adult, it was pretty much the same group there, except for on the last occasion.

THE LAST EXPERIENCE AT A SUPER FEDERATION MEETING

During the last occasion, it was during when there was some sort of an energetic barrier around the Earth that was preventing a lot of different non-terrestrials from leaving or coming.

And there were a lot of different extraterrestrials that were there that I hadn't seen before: a lot of different aquatic beings, a lot more insectoid-type beings, that had stated that they were here on our planet doing research but had nothing to do with humans.

They were more interested in our oceans or in our forests. They could care less about humans.

But they had people that were stranded here, and they were there to lobby The-Powers-That-Be to try to figure out how to get their people off of the planet Earth.

What was interesting about these meetings is that often they would announce themselves before they would get up to speak on this platform, but for some reason, that has been scrubbed from my memory.

There were other occasions where there would be non-terrestrials in the room, and it appeared as though they didn't have a face. You couldn't see . . . I mean, and it was something mentally that they were doing to you. It wasn't that they didn't have a face.

So there were a lot of different countermeasures going on in that meeting to make sure that I didn't, or the other people with me didn't, walk away with certain information.

And for the most part, when I would be used as an intuitive empath in those situations, usually, unless we were interrogating people, which occurred later on, we didn't pick up much.

We would pick up a lot of background emotion and energy that we would have to try to filter through. And a lot of them would be there, and we'd have to . . . Not only do you have a being that is completely different-looking than what you're used to seeing, they have a completely different emotional signature about them.

When you're interfacing with a human, I don't care if you get to a different country, completely different way of living, people are going to still have the same type of energy when they're sad, they're happy. You're going to be able to read it.

You have to establish a baseline with these beings, and it's very hard to do when you're not interacting with them.

So for the most part, we're trying to pick up anything that feels like deception, that feels like fear or panic, and relay that through handheld devices to the person in the meeting that we're supporting.

CHEMICAL DEBRIEFING

At the end of every one of these encounters, we were debriefed, and it was always a chemical debriefing.

They would use us, basically, as a USB drive. And they would put us in a situation, have us smell everything, hear everything, taste, see everything. And then when we come back, they have the ability to download that information from you in the same holographic chairs that they use to train you.

And when they download the information, they then go through a second process after the debriefing to where they blank-slate you.

And as many who watch this show will remember me saying in the past, 3% to 5% of people that they blank-slate begin to get the memories back.

And in my case, I began to get pieces of memories back very quickly. And then when you get pieces, you have threads to pull at, and then you begin to get the larger chunks of information. Then, when you get pieces of information that begin to connect, the full picture falls into place very quickly.

BEINGS AT THE SUPER FEDERATION MEETINGS

At these Super Federation meetings, the beings that were present were discussing genetic programs and a spiritual program that was ongoing on Earth. They were describing 22 different programs – genetic and spiritual components to these programs.

And there were 60 different ET participants in these programs.

A lot of these people at the meeting – and we were instructed to call the ETs “people” . . . When these people were at these meetings, you could feel the animosity between other groups. There would be some beings that there was just not a good energy towards another group. Or when another group would come a certain distance from them, their anxiety level would go up real high all of a sudden . . . would spike.

So I was able to pick out myself, before I read the briefings later on, that these beings didn't necessarily

get along all that well.

So to say the beings that I interacted with, or at least witnessed in these meetings, are good or bad would be very difficult to say.

The beings, when they were there, what was in their consciousness, was validating their program, their experiments. And they were there to present information about those experiments, and also grievances from other groups who had interfered with their genetic experiments.

So they were more focused on their experiment. So I would say most of them would be more amoral from our point of view.

There were a lot of different-looking beings. There were humanoids. We had some that ranged from 5' tall, 5½' tall.



This one right here that was depicted by an artist for us that I saw on the ship, they sat there and had kind of a smirk on their face the whole time and were mainly just watching. I did not see them actually get up and speak at all. They mainly seemed to be just observing.

And that seemed to be the case for several of the beings there. They didn't necessarily have a full stake in the genetic programs. They seemed to be there as observers. And this being seemed to be one of those.

I found it very interesting that some of these non-terrestrials looked just like us. Some of them had slightly different shades of skin, but some of them looked exactly like us. They could walk down our streets and maybe just look like a little bit of an odd human.

NORDICS

One of those groups was the Nordics, who I'd become familiar with earlier in life. My first encounter was with a Nordic.



The Nordics were very much involved. They seemed to have some sort of a clerical type of position in this council. And they had a lot of representatives at the meetings, and they seemed to be walking around and having discussions with little breakout groups of these non-terrestrials.

So they definitely have a pretty high involvement in all of these different programs that are going on. And a lot of people, they use the generic term “Nordic”, when there are a number of different species that you could call Nordics.

Some of them are very tall, 8', 9' tall. They have blond hair. They seem to always have a chili bowl-type cut, bobbed hair. And they have six fingers. They're very muscular. And they have blue eyes.



And there are others that are not necessarily from other planets that get lumped into the Nordic category as well – groups that are what we are calling Inner Earth groups that are very Nordic-looking and could easily be described as a Nordic.

HUMAN-LOOKING ETs

A lot of these non-terrestrials looked very human.



And this one looked very human. The male and the female did not have hair. They had blue skin, blue eyes, and they were very tall, probably 9' tall if not more.

They mostly were sitting down when I saw them.

They were very broad. They wore tunics, white tunic-type of clothing, and they had gold belts, very thin belts, around them.

And I never saw them set up and speak at these conferences, but they were present. My eyes seemed to just find their way to them quite often. There were a few beings like that.

These are the reasons these people are sticking out in my head so much, is that I was sitting there, and we were told to look at the smart glass pad and try to distract ourselves with the information there. But every once in a while, you would look up and you would catch eyes with one of these beings, or you would just see them, and they would be so striking-looking that you would just catch yourself staring at them.



And they did seem to have a very regal or very kingly kind of air to them. And they seemed to be very peaceful, but they were very confident, very, very confident, and seemed to be observing quite a bit.

EBENS

This should be a familiar image.



This is an image of what people describe as an Eben. And a lot of people have described being abducted by this group and have interacted with the Ebens.

A WATCHER GROUP

Now, there was one group in particular that seemed to walk around as much as the Nordics and interface with the other groups. And they also seemed to have a little bit of power, because these other groups would come to them and petition them to assist them in whatever grievances they had with other groups.

I think they are some sort of a watcher group that are observing and making sure that this experiment goes to plan and isn't taken in any one direction.

GREEN-SKINED ETs

Now, in this image, this is the green-skinned people that I've discussed before.



Their skin literally looked the same color of an olive, a green olive, that you pulled out of a jar – no difference.

There was a man and two females present each time. They are probably . . . The man was probably about 6½', 7' tall, and the woman was about . . . The women were about 6' tall. Very muscular.

The men had very short hair, like very military-looking, like a flat-top. The women had extremely long, shiny black hair, very shiny black hair, that went down to the middle of their backs.

And the women would sit with the male, and they would be very quiet during the actual meeting, but afterwards they seemed more like social butterflies. They seemed to split up and then go to each group, and they were obviously socializing.

ENCOUNTER WITH A GREEN-SKINED ET

And interestingly enough, my last trip, I had an encounter with one of the females. And it was the only time I had an encounter at one of these meetings with a non-terrestrial.

I was there, Gonzales was there, and we had some intuitive empaths that were Secret Space Program military guys.

And they were sitting there making jokes a little bit about her looking like Captain Kirk's girlfriend. And at one point, one of these females walked up to me, and she had empathically or telepathically figured out what we were talking about. I guess she was so much in our consciousness we became a part of her consciousness.

And she came over, and she asked us if Captain Kirk was someone that we served under. And it was pretty shocking. She came over and spoke in English to us and was asking if we served under Captain Kirk.

So it was a little bit of an embarrassment to me and those others.

ASIAN-LOOKING ET



Now, this image here depicts another of the very human-looking beings, a very Asian-looking being. Their skin was more of a slightly more orangish tint, and they had these blue kind of cat eyes, that the irises took up almost the entire eyeball that you could see.



I saw them interacting quite a bit with the other human-looking groups. They seemed pretty standoffish from the insectoid-type group.

So there seems to be some sort of a rift between those two groups, most likely a dispute in these genetic programs.

FELINE RACE

Now, she does have feline-looking eyes, but she is not to be confused with the actual feline race that I only observed one time. It was on the research vessel, and they were moving its body.

There was a capture or kill order out on these beings, and what occurred was these beings teleport

around, and they were able to catch one of them, and it died. They weren't able to keep it alive.

And it was a very lavender-looking, cat-looking being. And the head, the ears and the face looked very catlike. The body was more of a humanoid torso.

MANTID RACE

So this image here is depicting one of the Mantids, or a Mantis race.



They are very heavily involved in the genetic side of these 22 different programs, and they participate in several different programs.

People will often witness seeing Mantids with Greys or with Nordics, and even with Reptilians. So these groups work across multiple different genetic programs, and they are known as THE genetic masters in our local [star] cluster.

Now, you may remember a lot of these stories that are told from abductees, and you'll notice that they have very terrifying encounters with these beings.

The weird thing is, they . . . you don't pick up emotions the way you normally would from another humanoid-type of being.

Their communications with each other are through some sort of neural network that is like telepathy or a shared consciousness. And for them to connect with us and communicate with us is . . . it takes an effort from them.

They are totally divorced from us when it comes to emotion. So we could kind of call them amoral, but when they are interacting with us, they are not thinking, "Oh, this poor human." That just has not entered their consciousness.

They are there working on a project, and we are the subjects of that project.

TALL GREYS



The Tall Greys are depicted in this image, and they're called Tall Greys for the obvious reason. They're about 8' tall.



They look very similar to the classic Greys that are described by people, but usually, you see the 3~4' tall Grey beings next to these Tall Greys.

What these small Greys are are usually some type of biological robot, a programmed lifeform.

You'll see these small Greys with the Nordics. You'll see them with the Reptilians. You'll see them with any number of groups. It's like standard hardware or something out there that everyone uses.

It's like everyone's on a Mac or a PC. Everyone's using this type of technology.

Now, the Tall Greys are very much involved in the genetic part of these 22 different programs. They are in competition with the insectoid groups, and they are in competition with the humanoid groups as well, but they work closely with them in different aspects of these different programs.

So they are given more of a free reign to come down here and work amongst humans on these genetic programs, doing the actual hands-on.

A lot of these beings, they'll be the ones that come down and physically touch the humans and take the specimens and do the work, and they report back to this larger body.

Some people may also remember abductee experiences where they will describe seeing a Tall Grey and then seeing a man in uniform, in a US military uniform.

That is because there is a very strong bond and agreement between the Tall Greys and the US government, shadow government, that involves trading of biological specimens from off planet and technologies in trade for allowing them to come down and do their experiments without being interfered with.

And a lot of times, human military will be on these abduction ships as observers, taking notes of the names of everybody, the time, what was done. And they keep a log of that, because in the beginning, these beings, who are supposed to be giving us the information about who they were abducting, and then we found out they were not being honest with us.

So because we now have the ability through our advanced space programs to deflect ships trying to come into our atmosphere, they now have to work with us and allow human observers on their ships.

DRACO REPTILIANS

Now, you may notice in my descriptions I didn't describe seeing a lot of Draco Reptilians. That's because there is quite a bit of animosity.

These Draco are claiming that this body, this Super Federation body, long ago, millions and millions of years ago, 65 million, to be precise, had come to this planet and destroyed an experiment that was already well underway – a Reptilian experiment.

They claimed that the dinosaurs . . . They were doing some sort of an experiment of making a Reptilian mix with a mammal, a mammalian-type of experiment.

And that experiment was wiped out, and then the genetic farmer races came in, which became a part of this Super Federation, began to come in and tinker with the genetics and created a whole new mammalian, fully mammalian-type of experiment here on Earth, when beforehand the Draco claimed that it was their planet, and they had an experiment well underway.

Now, they had representatives that would be at these Super Federations. There were Reptilian-looking beings, some that looked very . . . like human bone structure that had like lizard skin stretched across.

I mean, they would look . . . They looked more like a mixture between humans and the Draco.

ANT BEINGS

So the Draco were not able to come to this meeting themselves, but they had different members, such as these different insectoid beings that look more like ants. These beings work closely with the Draco and will be intermediaries at these types of meetings.



BLUE AVIANS



So this image depicts an obvious different-looking being than what we've been discussing prior. And to be honest, I had never seen or heard described a being like this in the programs.

When I first was put in the programs, the Secret Space Program, I was first, for about 10 months, put into something called the "Intruder, Intercept and Interrogation Program". And I interacted with all different types of beings in that program.

In those programs, I'd never heard of a 8' tall bluebird being.

So in around 2011, I had this very vivid dream that you knew wasn't a dream, to where this Blue Avian being appeared in my dream and started doing these hand signs, connecting with me telepathically, and then kind of moving its lips around.

After that dream, I was extremely disturbed. I knew it was something other than a dream, and I'd never heard of a being described that way.

Eventually, it appeared in front of me physically, and I happened to be with my dog at the time. I was sitting on a couch, and my dog was next to me, and it appeared in a room. And it was a big shock to me and my dog.

The being was 8' tall, was blue, but looked very human. It had five fingers.

And eventually it communicated to me that it was a part of this group of beings that were here to assist us in our transition to a higher density.

They were here, and they could care less about the 22 genetic programs. They were here . . . It's more of an energetic and spiritual component that they're concerned about.

The beings at the Super Federation Council, we would consider them probably fourth or fifth density on the density scale. These Blue Avians, and the other groups with them, stated that they were sixth density and higher.

They were able to appear and disappear at will. And basically, it was explained to me that they match

their vibration for the location that they want to be at, and they just appear.

They're the ones that pretty much pushed me to come forward with my testimony. And they also introduced me to a number of other different beings.

MICA



They introduced me to beings such as Mica's people, which I've described on "[Cosmic Disclosure](#)" a few times, a very Polynesian-looking people, very peaceful, that are in our local star cluster – the closest star, actually.

GOLDEN TRIANGLE-HEAD



They've introduced me to other beings like this Triangle Head being, which I've never actually interfaced with and interacted with.



But when I was at a meeting on the Lunar Operation Command, I was put in the front of basically a conference hall, or, you know, like what you would see in a university with the theater chairs going up to the back of the room. And I was put in the middle of the room with no explanation.

After that, people started picking on me a little bit, because they didn't know what was going on either, and I was standing there completely frazzled at that point.

Everyone got quiet, and behind me had appeared Tier-Eir, which is the main Blue Avian that I interact with, and the other was this very strange-looking like 10' tall golden being with a triangle head.

It had three fingers on its hands and three toes, and it was using its toes like a tripod. And the toes were doing like this [flexing], and it was going up and down a little bit.

And it looked almost like it was underwater, because its arms didn't look like they had bones. There was just this wavy . . . They were kind of wavy and going up and down rhythmically. It was very weird.

And everyone got completely quiet at that point. And that's when Tier-Eir then interfaced with me and allowed the people in the audience to ask questions of him.

The Golden Triangle-Head had never made any type of contact with anyone.

BLUE SPHERES

What's interesting is though that there is another being that's a part of this Sphere Being Alliance that are actual spheres. Size really doesn't matter to them. They can appear large enough to encompass our entire solar system, which they have done, or they can be as small as a ping-pong ball.

And they are bright indigo blue balls that will float around. And they are the ones that have come, and they would pick me up and take me to meetings with Tier-Eir.

And he told me that they were ninth density beings, non-corporeal beings, that were part of their collective.

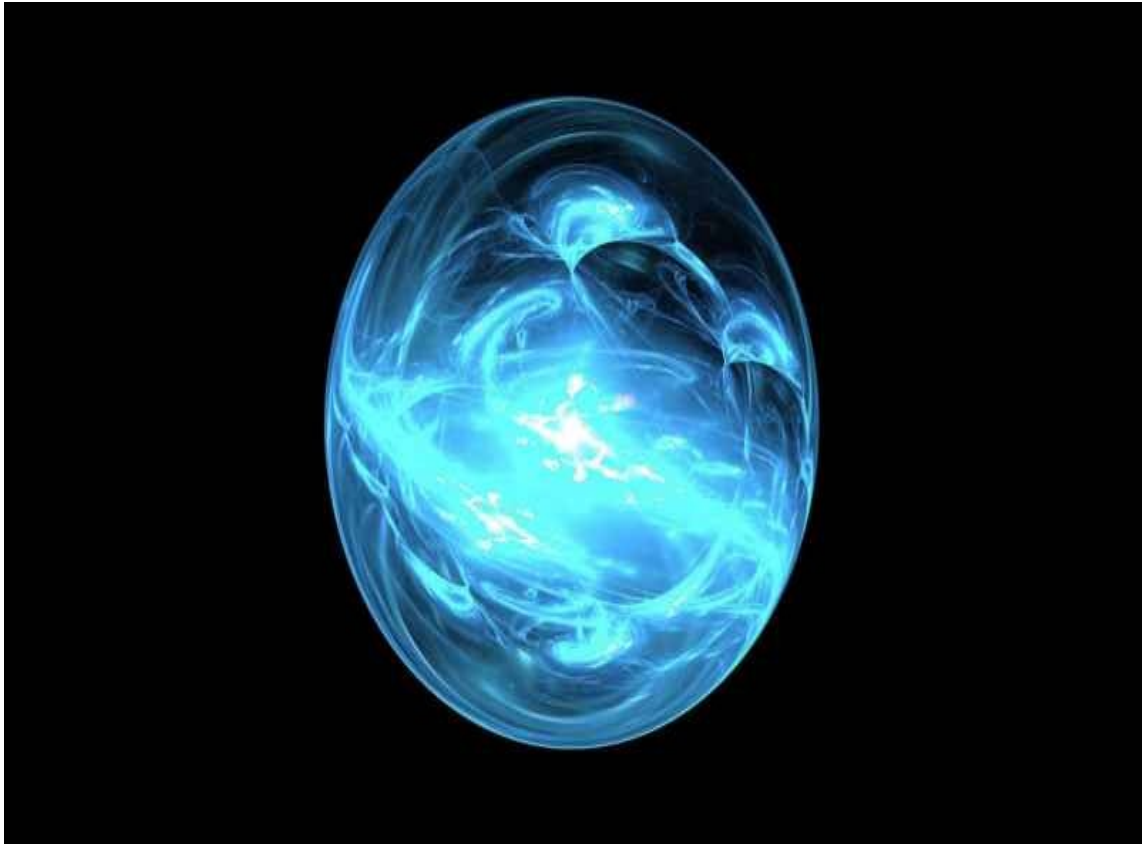



DRACO ROYAL



Now, this image a lot of people may remember. I had to meet this being. I was given very little prep time.

I was flown to what looked like a condemned hotel in the middle of the Midwest. It was desert everywhere.

We got up on the top of the building, and the ingress was through a door. Then we went through an elevator that went down into a large courtyard-type of area. All of the rooms were on the side, and it was empty all the way down. And there was a glass elevator that went all the way down to the lobby.

And as we were in this elevator and were going down, my anxiety level started going higher and higher, because I started seeing these beings standing down, looking up, watching us coming down.

It was a very . . . I felt like a fish in a barrel. It was a VERY uncomfortable feeling.

And the minute the doors opened, this musky, urine-y smell came into the elevator – very, very horrible smell. At first we were gagging, and we kind of got used to it.

We walk in and there are present, they had insectoid-type beings. There are other Reptilians that most people are used to seeing, the ones with the olive-green scales, holding long, lance-like weapons, standing at attention.

And in walks this 14' tall white lizard being that literally petrified me the minute it walked in the room.

I'm trying to keep my composure, because I know that I'm supposed to interface with this being.

And it walks up to me, and it walks up not RIGHT to me, but far enough to where it was very intimidating, and began to interface with me.

And when it did, it was not like the interfacing I had done in the past, where it was more passive to where I was going back and forth, conversation-wise.



It immediately, like a tractor beam, captured my consciousness and was reading what it wanted out of me. It felt like mental rape. And it was controlling me, and its eyes started doing this [**Corey** uses the thumbs and forefingers of both hands to move together and apart]. The pupils were going “vroom, vroom, vroom”. It was a VERY POWERFUL being!

A meeting with these beings is something I've refused after that encounter. It was terrifying.

Everyone that was in the delegation, the security guys, we were all keeping ourselves pretty calm and cool, but in the elevator ride on the way up and getting into the craft, we were shaking. Everyone was shaking so bad. You heard all the equipment rattling, and everyone was shaking from the adrenaline rush from after the encounter.

It was an incredibly scary encounter.

You've been watching “[Cosmic Disclosure](#)”. I'm your host, **Corey Goode**. Thank you for watching.

[Cosmic Disclosure: Emery Smith - Whistleblower](#)

Season 9, Episode 2

David Wilcock: All right. Welcome to “[Cosmic Disclosure](#)”. I’m your host, **David Wilcock**, and we have a special surprise for you: the insider who I referred to as Paul. And I can reveal for the first time that his name is **Emery** Smith.

And you may know him if you ever saw the movie, “Sirius”.

Emery, welcome to the show.

Emery Smith: Oh, thanks Dave. I’m so excited to be here – 10 years in the making of working with you and establishing a great relationship.



And basically, you're the reason that a lot of my progression in this field of undisclosed information has been brought to me.

And at the same time, it's time now to bring it forward, which, thanks for helping me get to that point, because, as you know, for the past three to five years, I was kind of just holding onto it.

David: Now, in the movie “Sirius”, . . .

Emery: Yeah.

David: . . . there is an autopsy of a little, six-inch tall, apparently extraterrestrial body.



Emery: Correct.

David: Who, in the movie, is doing that autopsy?

Emery: I was Vice President for CSETI for about five years, and what had happened was there was this being, of course, that was taken over by a civilian lab in Spain.

And the government actually did have it before anyone else, but no one knows about that.

David: Hmm.

Emery: So the thing was, the people I was working with in CSETI decided it would be a great idea to go over here, and “let’s do an autopsy, and let’s get some DNA, because if you get some DNA, well, that outrules everything. And let’s get a major university to do it.”

So being through my background, working with tissue from un-Earth origin in these compartmentalized programs – I’ve seen over 3,000 of these things – that it was just a winner for me to be the person to go do the autopsy on the senior team.

And I was definitely also assisted by Dr. Steven Greer and Dr. Jan Bravo.



So they were, of course, the physicians there witnessing this and helping me harvest this tissue.



David: I don't think anybody will forgive me if we don't talk, at least in this first episode we'll get started, about how you came to have multiple medical doctorate-level knowledge from classified military programs.

Emery: Well, I . . .

David: So can we talk about what you did in the military with this unusual biology?

Emery: Yeah, sure. You know, it all started, actually, when I joined the military at an early age. I was what they call a 90252. I don't think they still use those codes anymore.

But it had to do with being like a surgical technician – just a person who hands instruments to the physician.

David: Okay.

Emery: And I was also a paramedic and a surgical first assist, and then I became a teacher for that very quickly – overnight.

And then when I moved to Kirtland Air Force Base, they offered me a special, what we call “moonlighting job”, they call it.

And I was still a kid, you understand. I was very young, but I was very intelligent and very mature for my age at that time.

And I was fascinated when they were putting me in charge of million dollar equipment that not normal people would be able to even utilize or even . . . it's not even ready for . . . even to be used for civilians yet.

David: Right.

Emery: So that lured me into working this . . . Okay, “Well, we're going to say you're THIS, Sergeant Smith, but you're really going to be doing THIS. But you're still going to be getting paid.”

And I said, “Okay.”

So, basically, I'm working for civilian, compartmentalized programs, but I'm an active duty service member. And it worked out.

I know there was a lot of . . . I could tell that the people that I was working for in the operating rooms there, it was like, “Well, why is Smith always leaving every day at noon? Where does he go?”

“Oh, he has a knee issue. He has to go to physical therapy.”

So down the chain of command, they knew something was going on, but they also had to keep it justifiable, in a way, until “let's get him out of here, and let's go full-time with this, basically, dissecting tissues of unknown origin.”

And that's where I got sucked in and was just getting obsessed with what I was doing.

David: And you said this was Kirtland Air Force Base?

Emery: Yes, this was Kirtland Air Force Base, where I . . .



Yes, that's where I started.

David: Where is that?

Emery: Albuquerque, New Mexico. I was not just working there, I was moonlighting doing this other stuff after hours, and that had to do with Sandia and Los Alamos labs.

David: Sandia. Okay.

Emery: Yeah, Sandia Labs is another secured location on Kirtland Air Force Base.

David: Okay.

Emery: Yeah. It's like a base within a base that goes underground many, many stories.

David: So let's start to break into this a little bit.

Emery: Yeah.

David: And I've talked to you about this . . . I've gotten bits and pieces of this from you over a decade now.

Emery: Right.

David: And as time has gone on, you've been able to share more. You've been authorized to tell me more. So let's just put this on the record right now.

Can you confirm that you have been authorized to disclose what we're talking about now? That this is officially okay at this time?

Emery: My NDA [non-disclosure agreement] has expired, but I am still . . . I am not going to talk about something that I don't feel comfortable talking about if I don't believe it's something that would put you or me in harm until that comes.

But what I'm saying now, I believe, is going to be fine.

David: Okay.

Emery: I've not been threatened ever for any of that. The only time I was ever threatened is when I brought the DNA back from Atacama from Spain, illegally, from Barcelona.

And I thought when the government, when I was getting threatened, and they tried three assassination attempts on me, . . .

David: I remember.

Emery: It was very horrifying. I thought it was because that I took the DNA from, you know, over there, brought it here, and snuck it to Stanford, and it had nothing to do with that.

It had to do with someone getting upset with me because I resigned and then putting three compartmentalized labs that, during my work with this group, had their own team, their own wet teams, we call them, to come and do the little dirty work. [A “wet team” is an assassination team.]

But I was able to get out of that, thank goodness, to help from, actually, the U.S. government. And some military and CIA officials, Army and CIA officials, really helped out and turned around and threatened back.

And it was not only me, but it was also another colleague of mine that were working on that Ata [Atacama] being. And it was . . . Immediately, everything stopped. And I thought they just told me when I was taken to the wet room, because I was escaping where I was in Florida, getting all these threats.

They just flew me right there, next thing you know. And I just said, “What did I do? Why am I here?”

And they just . . .

David: Now, just so people . . . in case they don't know, the “wet room” has got tile on the walls, the floor, a drain in the middle of the floor, and the “wet” is your blood, basically.

Emery: Yeah. It's equipped, you know . . . This is where they take people and kill them, and it's an easy clean up. You've got a nice, big drain, a bunch of hoses.

David: Right.

Emery: And a huge disinfectant system.

David: And you knew what this was when they took you into it.

Emery: Absolutely.

David: And you were very intimidated.

Emery: I've seen different types of wet rooms, not for humans, but for other things and other compartmentalized projects, but never in Washington, D.C.

So they just said, "You violated your contract."

And I said, "Before you kill me, could you please show me and tell me where I violated my contract, and I'll be happy with that."

I said, "You know EVERYTHING about me. You have your own satellite on me. You know every phone, text message. You know everything." Everything is bugged. It's like, what did I do? Just tell me.

And eight hours later, I was sweating in this room, and they came back. They said, "We're very sorry, Mr. Smith. It was an internal problem, and you will never have to worry about that again. We apologize."

David: Wow!

Emery: And it was a really beautiful moment, because the first time that I felt like the Alliance of people in there were trying to protect me or trying to do something positive, besides expose me or hurt my family or, you know . . .

David: You go to Sandia, . . .

Emery: Yes.

David: . . . and . . .

Emery: Well, I'm already living there on the base.

David: Okay.

Emery: I already have my own place on the base. And I work at a hospital off the base. The VA [Veterans Administration] Kirtland Air Force Base Hospital is actually off-base, which is odd.

And don't forget, Kirtland Air Force Base is the fifth largest base in the world, and that's where they used to hide the nukes in the mountains.

David: Oh, wow!

Emery: And I've shown my handlers and people just flying over there to see the doors – those giant doors. But they're not used for that anymore. They're used for other things.

David: Well, we have New Mexico and Nevada near each other. And, of course, we have Area 51 in Nevada.

Emery: They're all connected.

David: So have you ever ridden the sub-shuttle system?

Emery: Only from Sandia to Los Alamos, and I might have went to Dulce and back, but I don't know where it stopped . . .

David: Hmm.

Emery: . . . because they had to do something. There's four of them, and . . .

David: Four of what?

Emery: These maglev-type trains.

David: Okay.

Emery: But from what I just recently heard, they're all upgraded, updated and completely different – more like a vacuum-tube magnetic thing.

David: Hmm.

Emery: And that's some other stuff I worked with. Just because of the tissue regeneration stuff I was involved with, a lot of the craft, . . . that I was brought into different projects to look at the craft, because the craft are actually alive.

David: Oh, wow!

Emery: Yeah.

David: The craft were alive.

Emery: The craft were alive, and they were conscious. Yes.

David: This is similar to what we heard from **David Adair**, where he described going to Area 51 and seeing this power system that was actually a living being.

Emery: Yes.

David: But it was this very large thing that had like . . . It looked like a skeleton over the surface of it. It had tissue components, but it also had technology components. It was some weird blend of technology . . .

Emery: That's right. It's right. It also . . . And that's already started. And I was part of that movement too, where we formulated tissue into titanium. It's called osseointegration.

David: Really?

Emery: Yeah. So that's a good one to get into at some point because that's what led us in the underground projects to say, "Man, if we can have tissue and titanium to be together, and I can make your bone tissue and titanium, you're going to be pretty strong, Dave. It's going to be hard for me to break that bone."

And then add stem cells to that and platelet-rich plasma, which increases bone density up to, sometimes, 10 times.

David: Wow!

Emery: Your own bone. Keep that in mind.

David: So that sounds a lot like "Wolverine" in the "X-men" movies.

Emery: Absolutely. So yeah, that's osseointegration, where they just, basically, you know, made him all these steel protective plates, but he also had a super ability to heal very quickly.

David: Right.

Emery: And that's the secret. That's what they all want to know: how do we have no downtime?

And now not do we not have any downtime, . . . and not just for the super soldier programs I was part of. I'm talking about the soldier programs that you don't hear about – the more upper-level Cabal, Majestic-type secret corporation levels, where they're trying to anti-age you.

And now that this new protein has just been discovered, A2M, Alpha 2 Macro Globulin, holy moly.

David: Yeah.

Emery: They just . . . They just turned back time.

And now that that's out, I can tell you right now, probably in 5 to 10 years – it will probably take 10 years for the FDA . . . What this does is it's a protease inhibitor, which means it blocks all inflammation. So the body can heal itself.

David: Hmm.

Emery: See, everything you have that you need to survive forever, or for a very long time, is already in your body. The problem is these fields around us and these . . . the foods we eat. Everything is poisoned.

David: Right.

Emery: So it makes us have inflammation. And I don't care if you're in a car accident, or if you have a disease, it all starts with inflammation.

Now, if I can stop inflammation, your body will heal itself naturally.

David: Hmm. That's very exciting.

Emery: Very exciting. And that by the way, that A2M, I did not discover that. I was just part of a project that specialized in that, and that's how I learned it all.

David: Sure.

Emery: And so I'm so excited now. It's here for the civilians, and it's all over.

David: Right. So let's talk about how you got started with extraterrestrial biology. Were you aware at first that you were autopsying ETs?

Emery: No.

David: How did they do that?

Emery: They . . . ha, ha . . . and it was really funny, too, because the entrance to where I was going was Sandia Labs, but it wasn't like in their compound. It was another little building. But it goes down 30 some floors.

And when I got down there, and they took me down these hallways, and they were just . . . On my first day, I just remember, I was in this little room, kind of like you would see in the movies where the room's kind of all white with the little table, steel table, and all these instruments there. And you're escorted to this place.

And you get in there, and there's this piece of tissue. And it's all positive pressure air system.

And so I go in there – and you do scrub out, just like a surgeon scrubs and puts his gowns on and the hoods and stuff. You do go in there, do all that.

And you label like you would like when we're in a biology school frog.

David: Right.

Emery: You're like, okay, this is a muscle. This is a tongue, or whatever. And I was just there to label and take small samples and put them in these different types of jars and vats and containers, which I would then push through a drawer in a wall, and someone else would take it, and that was it.

So I was basically taking tissue samples from whatever piece of tissue it was. Some looked like salmon. Some looked like . . . I don't even know. I can't even explain it.

But it then, every three to six months, you get a upper security clearance. So I stayed with that.

David: So you had described to me before that you called them salmon filets. Like when you first got started, would it be like a square, like this big or something? [**David** holds up both hands and makes a square shape about six inches on a side.]

Emery: Yeah. Yeah, it was like a perfectly cut square . . .

David: Okay.

Emery: . . . with arteries, veins, nerves, just different types of tissues. Different types of cellular tissues, I mean.

Sometimes you would find cartilage in a weird area, you know. And sometimes you would see neural matter. But it was always different.

And then the samples started getting more intact, where you could tell that, whoa, this is a hand, you know.

And I could not tell you what that is at that point. I couldn't even say . . . And you're not allowed to ask ANYTHING. You just do that, and you don't talk to anybody, and that's your job, and that's it.

David: What if you told your friends or your family? Like were you given security briefings about that?

Emery: Yes. That I would be killed!

David: Really?

Emery: Yes.

David: Now you say "a hand". I mean, describe what the hand might look like. Give me one example of a hand.

Emery: Well, imagine every creature on this planet that has a hand, and evolution them a billion years from now to have the five star . . .

David: Like the human star.

Emery: Human star. And so you might have a very small hand, and it might look like a frog, but it's just a little bit different. But it's a palm. Like, it's got prints.

David: Hmm.

Emery: It's got nails. It could be something like a raccoon hand. But we're talking everything's different now.

The most fascinating ones were the giant insect. These hands were just enormous. And they were not only living tissue, they were plant tissue as well.

David: Really?

Emery: Yes. So they had some sort of thing they were making or growing that involved plant tissue with some other sort of living tissue, which they would mix many different types of hybrid tissues together. It's old school. Everybody knows that in these projects.

And it's . . . You've probably heard about it out there. They've mixed every type of animal tissue, DNA, with every . . . with human to see what happens.

David: Like Dulce, New Mexico.

Emery: Yeah, all that kind of crazy stuff.

And then they started adding and adding and adding. And then when they started getting things from up there [space], that's when it got weird.

David: Hmm.

Emery: So whether or not this was an extraterrestrial [showing with his hands that he means one item, say, on a table], I couldn't say at that time, because I know they could have grew whatever this was and killed it, chopped it up in little, bitty pieces, sent it to all these places.

I wasn't the only technician doing this, you know.

David: Right. One of the things that I'd really like to drill into a lot more is if you can give us a much more exacting description of the facility that you worked in. So let's talk about that.

Let's talk about even something as simple as, is there a parking lot, or do you have an underground parking garage?

Emery: Yes, exactly.

David: Okay.

Emery: Kind of like you hear the stories about people flying out to Nevada or whatever to go to Area 51. There's only one way in and out.

David: Right.

Emery: Well, with these places, there's multiple places in and out, depending on where you're going to be working and what section.

And they're very large underground facilities. I mean, they're . . . We're talking up to 100 acres of multilevel facilities down there, with many special wings that do certain things.

David: Wow!

Emery: Some works on energy propulsion, some works on regeneration. Some works . . . There's a whole medical thing to it too, and there's actually a small little city of people that actually live there that do not come to the surface, usually, that I'm aware of.

David: Right.

Emery: And it's a very dynamic setup.

So for me, since I was already living on the base, it was easy because I just road my bicycle to this small building.

So the small building, which you would just think would be a fire tower or whatever, is actually just in the middle of a big area. And there's . . . You could park 1,000 cars there if you want. No one would even think anything.

David: Hmm.

Emery: So you go in, and you take an elevator down, and you get on a big hallway. It's an escalator. And the escalator, just like you would see at an airport, . . . and then the escalator's really long.

You're on the escalator for about 10 minutes.

David: Oh, wow!

Emery: So you're actually going somewhere else . . .

David: And it's moving fast?

Emery: Yes, it's very fast.

David: Really?

Emery: Yes. You can actually sit down on it.

David: What are you seeing? Is it a tunnel?

Emery: Just a tunnel.

David: Okay.

Emery: It's a hallway. It's white, and it has a black marble ceiling, like black onyx.

David: Oh! Oh, wow!

Emery: I don't know what it is, if it's . . . they can see through it, but it's a very different . . . Back then, that was very different to see, of course. And the tunnel is not big.

David: Do you think that one of these underground drilling machines could have made that tunnel, possibly?

Emery: Oh, yeah. The heat one did - the one that melts rock into a molten . . . That's how they made all the lava. They basically make lava tubes now.

David: Right.

Emery: And that's what they're still doing all over.

David: Okay.

Emery: Making an underground freeway to go anywhere you want in the world.

David: Now, when we think of an escalator normally, there's vertical metal grooves that are all side by side, and there's teeth between each layer.

Emery: No, no, no. This is completely flat and made of some sort of polycarbonate. And you couldn't see through it. And there's . . . You can stand or sit in the chair.

David: Oh, there's a chair?

Emery: Yeah. Yeah.

David: But you're on like a track, and it's moving.

Emery: You're on a track, and it's moving.

David: So what you're describing to me sounds like an extremely cool, futuristic tunnel that you're riding through. Like already, you're going to be pretty inspired.

Emery: Yeah, I mean, it makes Epcot look like a joke. Ha, ha.

David: Ha, ha, ha.

Emery: No offense. I know a guy who built that, too. But it's just like . . . At that time, you have to understand the year that we're talking about. In the early '90s, it was very fantastical to be part of all of this.

So when you get to the end, you go through your check station.

David: What does it look like? Where are you? What do you see?

You were in a tunnel, but what do you see once you get off the . . .

Emery: There's glass doors there, seamless. They open up like you would see in Star Trek. Like “whoosh!” They open up.

David: Oh, wow!

Emery: And there's these two stations. And if there's someone in both stations, you have to wait outside the glass. Other people might be before you, checking in.

David: Oh, they're being interviewed or something?

Emery: Yeah, they're being checked in.

David: Okay.

Emery: And so there's two other glass stations. So when you go, this opens up. Now you have a security check guy here [on the left] and a security check guy here [on the right].

David: So what would happen with these soldiers at the desks? What do you . . .

Emery: Well, they check your palm print and your retina scan. And then you show them your card – a very generic card.

David: And does the soldier talk to you? Do you have questions you have to answer?

Emery: Yeah, they ask questions, anywhere from just a couple, or sometimes they would be like, they're just like, “Go ahead.”

So they were doing this with people, and they had these special animals. They were dogs, but special dogs.

David: Special meaning what? They looked different than a dog?

Emery: They were somehow trained, or maybe a hybridized. They were a little bit larger, looked like a german shepard-mastiff mix and a bloodhound.

David: Really?

Emery: And they were there, and they were in like just a compartment, but they can smell you as you walk by them. For sure, you cannot walk by them without them smelling you.

And they always know how to . . . They go . . . They just right away smell.

And then you've got to go through two more doors, and now you're in the locker room. And they're gender doors.

David: Oh!

Emery: Female locker room and male locker room.

So in your locker room, you take your clothes off, and you put these scrubs on. They're kind of like scrubs, like a jumpsuit thing.

You go outside the next door, which has nothing to do now . . . there's a whole wall there. Now you're in another corridor, and there's a room on the right, and that room is where your orders are, and that's where you pick up your folder and your band.

David: Okay.

Emery: Okay. So . . .

David: Does somebody tell you your orders?

Emery: Well, they're usually just there. And sometimes there are – like, we call them the managers – are in there, because there is something they want to say to you. They already know a half hour away that you're coming.

David: Right.

Emery: So everyone knows everything, especially now that you've got your band on.

So they come in, and they'll say, “Hey, we got this, this.” They'll debrief you on like, “We got this, this, this, and just make sure you do that and that.”

And then you get out, and then there's the white guards, now. And they escort you. Or, if there's not a white guard there, you follow the color strips.

David: What are color strips?

Emery: Color strips are when you're walking down this beautiful, white hallway, there are wings of operating rooms, okay, pressurized operating rooms. Looks like you're getting in a 747 jumbo jet, because the doors are these cool, big, hexagon vacuum-sucked doors.

David: Wow!

Emery: And the colors correlate to the wing you're going to work in that day. And that just tells you how many wings go down there. Each wing can have up to 30 to 50 rooms.

David: Wow!

Emery: Yeah, of these types of vacuum rooms.

David: And how many floors do you think there are?

Emery: Where I was?

David: Yeah.

Emery: Oh, over 50.

David: Wow!

Emery: Over 50 floors, just in the medical one.

David: So once we understand exactly what you're doing, then the number of extraterrestrial bodies that these guys have must be staggering.

Emery: Oh, it's unreal. I mean, it's a . . .

David: And you said you never really saw much repetition in the type of stuff that you saw, once we get to that point in the story.

Emery: Right. No, it was different work.

David: It's always different.

Emery: Always different. But the thing was this, did they grow that here? You know?

David: We don't really know.

Emery: It's disinformation too, because they're going to throw a couple of disinformation things at you in case one day I go public. And no one is going to believe me that I saw a 10-foot Reptilian going down a . . . I mean, being escorted down the hallway.

David: You're saying you did see a Reptilian?

Emery: I'm saying I saw a lot of cloned, hybrid, 3D-printed beings. Whether they were conscious or not, I do not know. They're really good at sci-fi effects, too, to mess with scientists, or to threaten them if they feel they're about to go public, and they would talk, when you work there.

So the best way to do that is to show them something that's completely horrifying, and then they think they're going to go say something, or leave, or do whatever. But now that they know it really does exist, but does it? Is it real?

David: Right.

Emery: I don't know. I can't tell you. I don't know.

David: Right.

Emery: Just because you see it, doesn't mean it's real.

David: Right.

Emery: The same thing with the new satellites we have with . . . we're projecting stuff on cars, on the ground, and cast shadows now. Palpable systems that look like I'm right here, but I'm really not right here.

David: You're saying they could project something that looks just like a car, with a shadow, but it's not really a car? It's just a projection from a satellite?

Emery: It's a projection of a car that is palpable.

David: Wow!

Emery: But you can go right through it, if you were to really walk up to it.

David: Wow!

Emery: But enough to put that amount of atoms into an area and reflect light.

David: Interesting.

Emery: Yes.

David: Interesting.

Emery: Which is a whole 'nother ball game.

David: Yeah.

Emery: So it's hard for me to say, "Yeah, I saw this craft," or "I saw this ET," or "I saw this hybrid," or whatever, unless I actually touched it and felt it and walked on it and tested it myself.

David: Okay. Well, since we have talked about those types of beings before, instead of giving you any front loading, could you be more specific in describing . . . You said it was 10 feet tall, but could you describe a little more about what it actually looked like?

Emery: I was just using that as an example.

David: Right.

Emery: But I will describe other ones that I've seen.

David: Okay.

Emery: And other ones I've seen were anywhere from 8 to 13 feet tall down to just 22 inches.

David: Hmm. But some of them, you said, were alive, like they might be carrying it as if it was their prisoner?

Emery: Well, yeah.

David: Okay.

Emery: Yes. And that's the reason I kind of opted out after 10 years, because I felt that something wasn't going right, because one of the bodies I received was warm.

David: Right.

Emery: So I knew it just, obviously, passed. So then I put in my thing, got honorably discharged, and got out of the contract work, and kept my mouth shut for 15 years, 10 years.

David: So a warm body means that it might have been killed right before you had to autopsy it?

Emery: Correct.

David: Right.

Emery: Right. But I have seen live extraterrestrials face to face.

David: Or something that was ET-like.

Emery: ET-like or hybrid or clone. Cloned individual from an ET.

David: Okay. Let's get back now to your colored lines.

Emery: Yes.

David: I want to get us into the room before we end this episode.

Emery: Sure.

David: What happens when you get to your door?

Emery: Well, every corridor, don't forget, has the white security guys there.

David: Okay.

Emery: So you're never going to not see these guys.

David: Right.

Emery: They're posted on every corridor. Corridors can go very, very far.

David: There's no private area, then.

Emery: No way! There's NO private areas. Yeah.

David: Right.

Emery: So what you've got to do is, when you get there, then you have to go through the pressurized area to put your suit on.

David: Okay.

Emery: And that's the clean area, the sterile area.

David: So there's like an air lock in between the door and the operating room.

Emery: Correct.

David: Okay.

Emery: And now you put more . . .

David: Now, you put more . . .

Emery: And those two technicians run that with the two soldiers, right, the white guys.

David: So you have your scrubs already, but then you put on additional equipment?

Emery: You have to put . . . Oh, yeah. You have to put on the suit.

David: And what is the suit?

Emery: Like a space suit. It's a very lightweight spacesuit, like you'd see in the movies. It's all glass. You have your own little oxygen that you plug into the wall of your unit. So you don't have to carry anything. It's very lightweight.

It's made out of like a Gore-Tex, polyurethane substance. It's waterproof. It's completely air proof.

I mean, you have your own air recycling in there. You have your own speaker comm unit. You can communicate.

And the gloves that you're wearing on these suits are the same gloves we use in surgery. They're very ambidextrous, very sterile.

Sometimes you will have to use certain gloves that are made out of something else that I don't know,

because they don't want certain latex or non-latex things to be touching . . . to actually destroy whatever you're touching.

David: I see.

Emery: So there's different types of suits for different types of autopsies.

David: Oh.

Emery: Yeah.

David: So you said . . . I'm trying to see this. You have like a hose that you're going to plug into the wall . . .

Emery: Yeah.

David: . . . once you go through the airlock?

Emery: You get to the airlock, . . . You know, you're escorted by the security guys. And they open the air lock, just like you would see on a Navy ship, kind of . . . like on a . . . Some have clamps, and some have these little things.

And then you go in, and you're suited, and you just plug your stuff in.

There's two cords: oxygen and an electrical comm cord.

David: Okay.

Emery: And you can still hear them if they wanted to talk to you in there without that, in case it failed.

David: So could you just briefly describe what it looks like once you're inside the OR now?

Emery: It's seamless. It's got a white-pinkish-tinge to the walls and everything. It's kind of oval.

And all of the entire walls actually have . . . can come out in different types of sections. And the sections might be . . . the body will be on this board. And then the other section walls will have all these other tools you're going to need to do it, to do whatever you're gathering or for the testing.

David: Right. So once you actually see these salmon filets, you said it started with salmon filets, but then you upgraded at some point to an arm with a hand.

What was the time interval between salmon filets, and arms, and then, eventually, full bodies? Could we talk about that for a second?

Emery: Yeah. That took about, I think, 16 months. You get three to six months security upgrades if you behave and keep your mouth shut.

David: Hmm.

Emery: I mean, it happens fast, because they go through so many people. And I really wanted to learn this. I was so captivated by it, so I did what they wanted me to do. And then it got more and more stranger, and I would get better and better samples.

And it was frustrating because you're not allowed to ask, well, "What is this from? Where is it?" Or, "How do you get it?" Or . . . You're just there to do the sampling and get out, you know?

And then once the bodies came . . . that was probably after maybe 10 months when partial bodies, not full bodies . . .

David: Oh.

Emery: I didn't get full bodies until way at the end, and then I got out because I got emotional about it, I guess.

David: Could you describe for us the very first partial body that you saw? What did it look like? And we'll end the episode with that.

Emery: Yeah. It was a leopard-colored skin. It was the torso. It looked like it got blown up. And it had Reptilian skin. It had normal body parts like we have on our insides. So I did see a spleen, a heart, lung.

The face was too distorted and destroyed, so I couldn't tell you what the face looked like, but it had perfect, normal bone structure like we do. And it was just . . . The skin was beautiful. It was iridescent blue leopard skin.

It reminded me of growing up in the Everglades with the leopard frogs, where they had those round circles and peacock feathers mixed.

David: Really?

Emery: Yeah. That color . . . That distinct, round . . . It was very smooth skin.

David: Did it scare you the first time you got a partial body?

Emery: Yeah.

David: Were you like, “Oh, my god! What's going on here?”

Emery: Yeah. I was in shock. They're measuring my heart rate, by the way, the whole time. They're measuring how I'm reacting.

So I kept cool, and they didn't ask me, “Hey, are you all right?” one time, because I was only allowed to operate on one part of the body. And I wanted to know more, you know?

David: Right.

Emery: Because there are certain tissues, I realized, from clones, than from real extraterrestrials and from humans, that the cloned tissue isn't as strong as the ones they grow.

Our tissue's really strong, but . . . And depending on how long they've been, of course, dead, or how long it's been frozen, or whatever conditions they have had it in.

But when you get fresh stuff, . . . and sometimes they'll tell you it is, sometimes they won't. And you can tell that the ones that are fake are more friable. So that means you barely try to get something out of them, it just, like, melts away.

So it's a very interesting dynamic as far as the tissues are concerned.

David: **Emery,** why do you feel like coming forward today? What are some of the events that have just happened that have impelled you to finally break your silence after a decade of me telling you, “Hey man, you really ought to come forward?”

Emery: Well, you know, I didn't think that's up to me, you know, because I'm a very just neutral . . . You know, I don't even watch a lot . . . I don't watch a lot of these shows, and I like to stay neutral, so nothing influences me.

David: Right.

Emery: And recently . . . [PAUSES, BECOMES EMOTIONAL; TEARS] You know, it's got . . . It's been getting a little violent.

David: We have a photograph of a head-on collision that you suffered 30 minutes after I leaked more of your information in an article.



And you're very lucky to be alive.

Emery: Yeah. Yeah, I mean, it's . . . I've been shot at, been stabbed, been jumped by three agents, got my butt kicked. I mean, that's . . . I've been through it all.



But it was not . . . it was . . . I don't believe it was because of THAT stuff.

I think when they knew I went energy, when I started doing more of the energy stuff, they REALLY got angry.

David: Yeah.

Emery: And that's where I lost everything. They broke into my house.



I mean, rammed my gate, my concrete gate, down, you know, where all this stuff was stored.



And cut into the walls where things and safes were hidden that you can only know by satellite, using . . . These people definitely had perfect satellite imagery of . . . You know, I KNOW about the satellites very well and the stuff they can do with them.

They can look into every brick and every wall of the house.

David: Wow! It's unbelievable. I'm very glad that you made it here alive, that we're doing this now.

We're going to try to get as much on camera as we can for your safety.

Emery: Great.

David: And we'll be back next time. This is "[Cosmic Disclosure](#)". I'm your host, [David Wilcock](#), here with "Paul", who we now have revealed is **Emery** Smith. And thank you for watching.

Cosmic Disclosure: Inner Earth In Crisis

Season 9, Episode 3

David Wilcock: All right. Welcome back to "[Cosmic Disclosure](#)". I'm your host, [David Wilcock](#), and I'm here with **Corey Goode**, once again bringing you vital updates for this on-going amazing saga that we have been experiencing.

Corey, welcome back to the show.

Corey Goode: Thank you.

David: One of the things that you've shared with me in our private conversation is that you had some new interactions with the Anshar that are actually quite interesting. And apparently this is sensitive enough that I'm only going to hear this for the first time as we're talking about it on camera, so I'm excited to hear about this as is everyone else.

So what's going on in the Inner Earth planes at this point?

Corey: Well, it's not real shocking information at all.

David: Okay.

Corey: What occurred is they brought me down to . . . I was brought down to the temple complex area again. And I was brought right past the area where you cleanse.



They didn't have me do that. They had me walk directly out into the corridors that brought me out to the city area, or the cavern area where the cities used to be.

David: Okay.

Corey: In the temporal bubble that was created, they had us fly in.

David: Just to recap, what I remember you telling us before is that the Anshar have actually gone into some sort of protective field because of the possible Solar Flash and they don't know when it's going to happen.

So is that the nature of what this is?

Corey: Right. They create this bubble every time there is one of these cycles that occurs.

David: With the Solar Flash?

Corey: With Solar Flashes and just the other cycle . . . all the cycles that occur . . .

David: Right.

Corey: . . . over time since they've been here. They put themselves in this temporal bubble.

Now, when they flew us in in one of the shuttle craft, Anshar buses, that I've described before, it was huge.

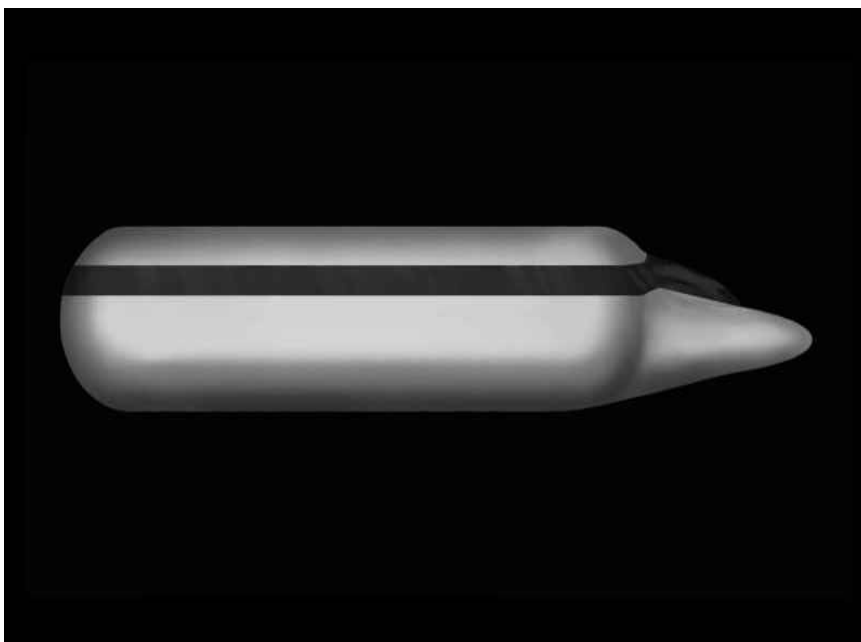

I mean it was huge. There were a lot of them – a lot of people.

David: What was huge? What did you see? The bus was huge?

Corey: No, the inside, all of the different city components were connected like . . . almost like Legos . . .

David: Hm!

Corey: . . . like electromagnetic “Zetz”, connected to each other, and they were all over, 360° all around and looking up . . . If they were standing looking up, they'd all be looking to the same point in the middle of the sphere.

David: So, again, just to clarify this, you've said that these units that they were living in in the Inner Earth caverns are modular, and they are like little spaceships that can move on their own.

Corey: Right.

David: So they have now joined together like Lego blocks . . .

Corey: Yes.

David: . . . inside this bubble?

Corey: Yes.

David: How spectacular was this to see? Was it a really stunning thing?

Corey: YES! The thing is, when you first fly into the event horizon of this one . . . I did not experience this when we were going to the temporal anomalies on Jupiter. So it was a little different.

As soon as we went through the event horizon, it was kind of like being exposed to a heavy amount of electromagnetic field. I kind of fell to my side and almost kind of passed out.

David: Wow!

Corey: And very quickly after that, after we passed that barrier and went in, I was fine. I was just kind of a little out of it and coming to.

David: So this is a time bubble as well as a dimensional space of some kind?

Corey: It is a temporal bubble that is created outside of this reality space-time.

David: So whatever happens to the Earth, even if it moves in an unusual way, they are not going to be affected by that.

Corey: Yeah. The energies are not going to affect them. They are completely segmented from this reality, I guess you would say.

David: Is it in a higher dimension but somehow still local here to Earth? Or where is it actually physically?

Corey: Well, just like the temporal bubbles that they have outside of Jupiter and Saturn, they are accessible from many different galaxies . . .

David: Really!

Corey: . . . and many places in this galaxy. You go in, and you think that you've just traveled a few thousand meters through a barrier and then you're in this dark place.

But really, you're nowhere in our space-time. You're nowhere. And all of these other galaxies have tunnels that get them to the same point. They can travel in, and it's a real quick trip. It like just traveling to the Moon kind of distance.

And then at that point, everyone's together but when they're really many, many thousands and millions of light years apart.

David: So you're saying this temporal bubble that you went into is potentially accessible from multiple points in our galaxy and even other galaxies.

Corey: It is, absolutely.

David: How would they have any protection against an invasion in that case then?

Corey: The way it is designed, you can only go . . . they call it “punching in” and “punching out” from the same trajectories.

When you come in, you come in and then you come to the meeting spot or wherever you're going, and then, I don't know if it's technology, harmonics or what, then they are only allowed to leave through that same point that they punched in, which will bring them back to their space-time.

David: Are these people using languages to talk to each other, or is it all telepathic? How does the communication happen?

Corey: No, they were using a language – that weird . . . they say it's Akkadian like, but the only thing I can image is, imagine someone that grew up in Turkey, and they have the Turkish accent, and they were taught an old dialect of German or something. Imagine how that kind of might sound. It's very, very weird.

But, yes, they were communicating in that common language.

David: They speak with their mouths.

Corey: Yes, they were speaking.

David: Were you able to understand any of it?

Corey: No.

David: Okay.

Corey: What happens after we landed, they brought me down into one of these domes, and at the base of the dome, they were having a discussion.

And it was interesting to me. They had all of the seven different groups that I first saw when the Anshar had their first meeting that I was invited to.



David: Oh!

Corey: All these different groups were there.



David: Now, just to be clear, you had said before that this is the people from Earth's future that had time traveled back, so all the different racial types on Earth are represented in these groups.



Corey: They are. And, yes, that is what they claim, that they come . . . Each of the different racial groups that are here, are here pretty much on the same mission, but they came during different time periods.





They didn't come at the same time the Anshar did.

David: Okay. Interesting.

Corey: So what was going on is there was a discussion going on about how they were going to integrate some sort of technology that they all share.

And as I've told you, in the past, their technology is powered and controlled all by consciousness. So there are really not a whole lot of physical devices around.

So this was the first thing I was shown.

And they were showing above a small, squared desk-looking thing, they were showing a hologram up of these long square-type blocks that, in the middle of them, were almost like cables. They were very large crystalline like cables that went through that were impregnated in a spiral with some sort of mineral. I don't know what it was.

David: Let's talk for a minute about what the boxes are. What are they connecting? What does this do for them?

Corey: It's going to allow them to network together all of their consciousness to be able to help them power and control technologies that they're planning on using in there for however long they are in there.

David: Now, if I remember correctly, when we first started talking about this, you said that different groups had amulets with little jewels on them that showed what part of the Earth they were living in, and they had different regions for different groups. Is that correct?

Corey: Right.

David: So you might have people that look Asian, but they are going to be in one area, and people that look Nordic might be in another area.

Corey: Yeah, they weren't all mixing together. They had their own blocks or areas. That's correct.

David: Now the priesthood that you originally went into with Ka'Aree, that was some some sort of summit that was happening at that time where they were bringing their troops together so to speak?

Corey: Yes, a very rare meeting of bringing all of the decision-makers together. And the decision-makers happen with all of them . . . pretty much all of them. One of the . . . Some of their religious caste are also somewhat warrior caste.

With that Omega group, it was more that way with them.

David: Right. And you had said that the reason they were first coming together was threats from the Cabal actually trying to wipe them out.

Corey: Yes, well, they had a number of disagreements with non-terrestrials that are in competition for a different future.

David: Hm.

Corey: So, yeah, there were . . . they had that component. And then they stated that the people of the surface had developed technologies and weaponry that now reached them as far down as they were.

David: So it sounds like the meeting that you're being taken to now, there's a deeper level of cooperation and affiliation than just that initial negotiation that you saw the first time.

Corey: Yes, and this is something that apparently they do every 25,000 years or so.

David: Hm.

Corey: They come together and stay together in this bubble, basically, and then afterwards, they leave, and then they do what they need to do. They see how far the timeline is off, if any, from when they went in, and then they begin trying to manicure the timeline again to get it back where it should be.

David: So these cubes with the Mylar-type of cable between them, is this the equivalent of them creating an Internet where they have access to all of their mutual intel, that kind of thing?

Corey: The information is shared on a wider bandwidth range – wirelessly, I guess you would say. These are basically almost like cables coming together that reroutes . . . And all of them are putting off energy and consciousness, consciousness energy. That is being harnessed in this technology to power various different types of technology.

And they can also control technology that's in other areas that way, so I guess it is networked in that sense.

David: Did you have the different groups putting their various cities together like Lego blocks in the one temporal bubble? Is that part of what this was?

Corey: Yes.

David: Okay.

Corey: Yeah.

David: So it's . . . In a sense it's linking everything up once they go into that bubble. Why do you think that you would have been brought in to see this meeting? What would be the reason why you would be communicating this to us today?

Corey: Well, that was the strange part of the whole thing. Aree [Ka'Aree] told me that we needed me to witness it and to help arbitrate it, but I didn't know where to begin.

At one point, I got real close to the desk, and I leaned in to look at the hologram, and they stopped talking. They looked at me like I was interrupting.

David: Hm.

Corey: It's like they had me in the room for some reason, but they didn't want to have me in the room at the same time.

And then afterwards, she just . . . we went back to the Anshar bus. She flew me back through the temporal bubble and to the cavern. And then we walked back. We had a few conversations about some action items she had given me about different changes to make in myself, but other than that, that's all that event was.

David: Well, there's one thing that I'm not really clear on, which is, if they're coming together in one bubble, and they're linking their technology together, then what's the argument? Why would they have any differences of opinion?

Corey: In how . . . In how it was coming together. That was the last component that they had left. They had pretty much connected all of their cities together, and then now, . . . and they all have their separate self-contained consciousness energy grid.

And then they were being very tentative on how they wanted to connect that with other people's grids.

David: Hm.

Corey: So I don't know fully if it was security, just old type of maybe competition between certain groups, but everything else had worked just fine. They had all these areas that were all just snapped together all around.

David: You had also said before that some of these groups were kind of adversarial to one another, that they might not all have the same agenda. Some of them might have an agenda that wouldn't be as favorable for us.

Were those negative groups also involved in this, or was this just . . .

Corey: All of them were together.

David: Really?

Corey: Yeah.

David: So do you think part of the argument might have been that maybe these more adversarial groups would have had all of their communications exposed if they made this grid, and they had things they wanted to hide? Do you think that could be what it is?

Corey: No. At that level, the fourth density, there's no hiding anything, really. It's such an expanded consciousness, and connectiveness. They're all connected in a way that we just really can't understand.

David: So did you ask Aree why you were invited to this and what was the agenda for you to see it?

Corey: She said, as a part of my role, I needed to be an observer.

David: Hm.

Corey: That's pretty much all the explanation I get.

David: How do you think . . . and I know you're probably going to have to speculate, but if you can speculate, how do you think this event and this negotiation affects humans on Earth now and humans on Earth as we go through the Solar Flash and after the Solar Flash?

Corey: What the Anshar are doing right now in the temporal bubble does not affect us at all. What they are doing in the temple complexes, and what the other beings are doing in their temple complexes, is germane to us on the surface.

David: In what way?

Corey: They're reaching out, the way I've explained before. They're reaching out, connecting with people on a higher-self level, basically making an agreement on how each individual will be brought up to speed or awoken to certain information.



A lot of it is being done mainly in downloads, which is not what I expected. When they said “dream state”, they also included downloads.

I'm getting emails like crazy about people talking about the downloads that they're getting. And they're pretty bizarre and amazing.

But they are also reaching out to people in dreams more and more.

David: You had said before, since we're on that topic, that this initial contact – telepathic-type contact – would segue into some sort of in-person meeting that people might have on larger-scale levels.

Have you heard anything more about that since the last time we discussed it?

Corey: No, I have not.

David: How do you think that's going to manifest? Will it right before the Solar Flash? Because you had also said – and I want to link this to something else . . .

The Blue Avians at one point had told you that as we get close to the Flash that people were going to start to see ghosts, and it might be relatives or people that they knew who had died.

Corey: Right.

David: How do you think those two things might be related?

Corey: The closer we get to that Solar Event, whatever it ends up being, the higher the energy build up is occurring.

So, yes, we're going to see crazy people acting crazier. People cannot hide their agendas anymore – who they are. It's just . . . It's out there for everyone.

It's so much so that I think a lot of people . . . they're not even trying to hide who they are anymore.

David: As an intuitive empath, did you get a sense that these groups were partly discussing how they would interact with us before this shift takes place, like what their strategies were? Was there some debate over how much to contact us or how little to contact us?

Corey: Well, there were big debates on whether to contact us at all.

David: Oh!

Corey: And only a few of the groups really decided to break these Mohammad Accords.

David: Hm.

Corey: And I definitely think that they would start having the face-to-face contact with people before this Flash or Solar Event, because afterwards doesn't . . . you know, yeah, they could show up. We're going to be different. We're going to be closer to them than we are . . . what we are now.

David: Do you think that as we go through the Solar Flash, that if people need to be portaled out of Earth, like it seems to say in so many of these ancient prophesies I've been discussing on Wisdom Teachings, that they would be taken to this temporal bubble?

Corey: I'm not sure. I've talked to several people lately, including Hopi and Zuni, and a lot of them talk about being taken into a cave or a portal, and then being gone like a 1,000 years, or so, and then coming back.

And they may not necessarily be living underground. They may be being portaled to a planet similar to Earth where they are refugees, just like I've described happens here on Earth during certain times in our past.

Different beings like the Mayans were brought here as a protection.

David: Another thing you've been sharing with me, now that we're getting into some of this more off-planet type of stuff, is Gonzales apparently has still been meeting with you. And to me this has been very mysterious because most of this stuff you won't say anything about what he's saying or what's going on.

So, could you tell us anything that you can share about what's going on with Gonzales at this time?

Corey: Yeah, Gonzales, I meet with him usually 7 to 10 days apart. He's helping monitor and manage some of the things that are going on because of doing so many 20-and-backs and being in close proximity to so many different types of technologies that have high EM fields.

David: You're saying that you . . . He's monitoring you because of that?

Corey: Yes.

David: And what would be the . . . What would be needed to be monitored?

Corey: They're monitoring certain things that are going on with my brain and brain chemistry, watching for temporal dementia to onset quicker, and they are keeping it at bay.

But my memory is being affected. I'm having some issues here and there.

David: Hm. Does he have any technology that they can use to help you? What is the form of the monitoring? Is there actual treatment?

Corey: Well, it's what I've described before. I'm brought up to this big cylindrical, stone Mayan ship.



David: Okay.

Corey: They walk me into the rooms that have the floating panels - the different lights flashing on them.

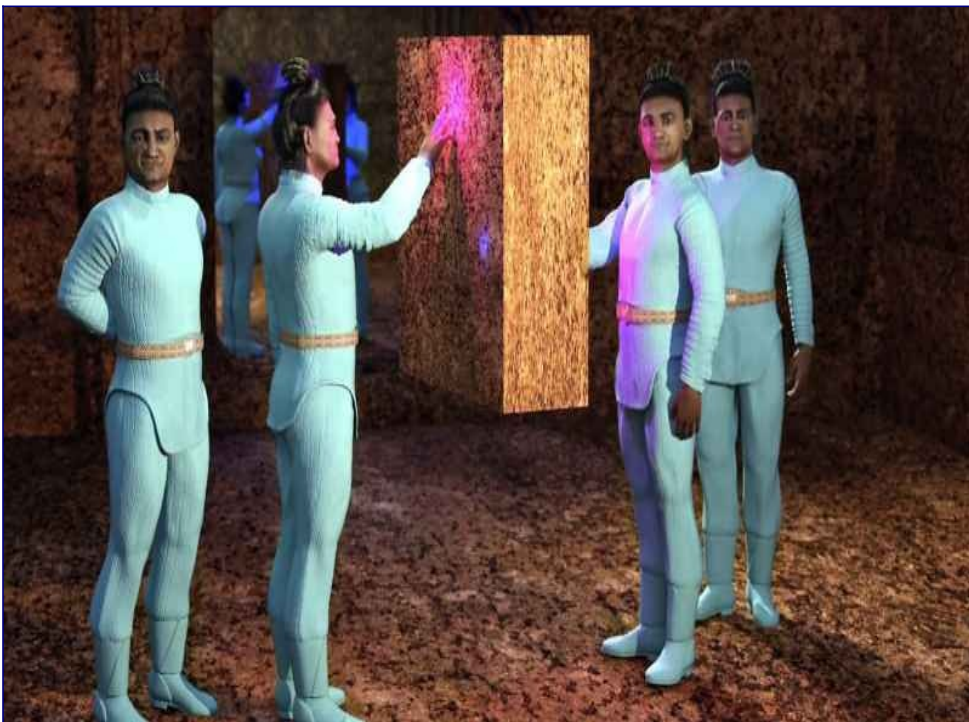

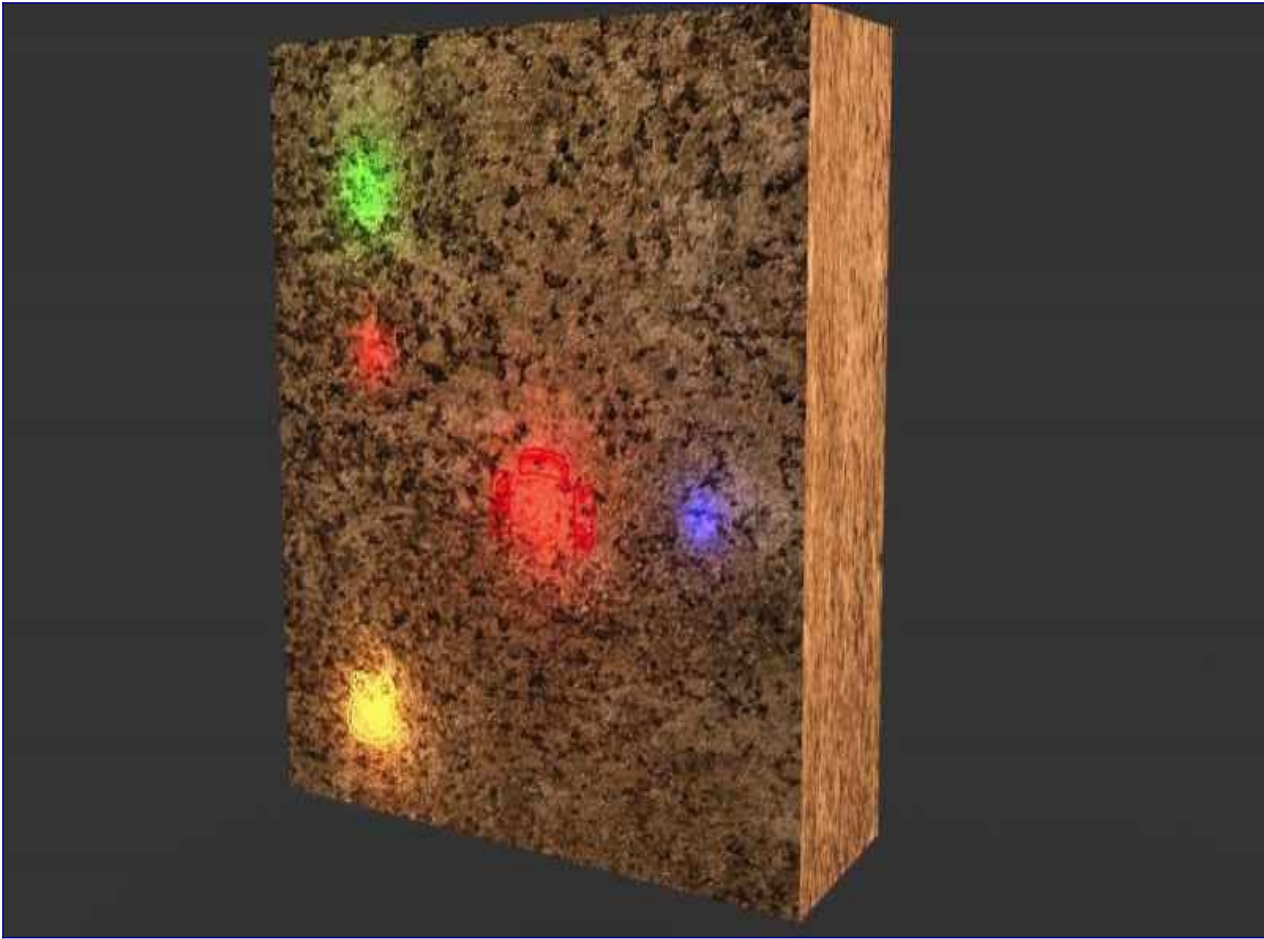

And Gonzales removes a . . . like a black 8-ball-looking sphere, stone sphere, from them, and walks up to me and scans my forehead.

He's scanned the rest of my body before with it, but routinely, he uses it to scan my forehead.

And while that's going on, similar to when they used the halo on me, he'll discuss, "You're going to feel a sensation here," and then inside I can feel like a "Zzzh", "Zzzh" sensation. That kind of thing.

David: Does it also provide treatment, or just diagnosis?

Corey: Treatment as well.

David: Okay. And this is treating long-term damage from, as you said, multiple 20-and-backs and also exposure to weird equipment.

Corey: Right. Typically what happens is, people that are exposed to those types of magnetic fields, leaving the 20-and-backs out of it, these technologies, you begin to have major eye issues, a lot of

neurological issues occur, and then those usually occur first, and then the temporal dementia starts to occur. And it's pretty scary.

David: Is there any other aspect of what has been going on with Gonzales that you are authorized to tell us right now?

Corey: He's been working very diligently for a while now to reinvigorate the SSP Alliance that pretty much all went to ground.

David: Hm.

Corey: You know, right after several were exposed, and Sigmund's men started rounding them up.

So what he is doing is he's getting command and control communications rolling again.

There's a lot of stuff going on in the background that has eyes on a different problem and not them. And the problem is all of this information starting to come out, be exposed. How are they going to let it be exposed? What will they share? What will they not share?

Different groups competing for . . . all with different agendas.

David: Some of the briefings I've gotten from **Pete** Peterson recently have said that there is still a pretty active battle going on between Draco-type Reptilians and their groups and some of our own groups with our technology.

And he said that sometimes we're gaining and sometimes we're losing in that war, but that it's an on-going war – lots of ships involved, lots of casualties involved.

Do you have any news on that?

Corey: It's kind of a weird situation they have with the Reptilians. Certain aspects of these Cabal groups are working with the Reptilians, or at least they are being allowed . . . the Reptilians are allowing them to have certain areas of Antarctica.

And there are other factions within the Programs that are more on the side with the Nordic groups and are trying to get rid of the Reptilian influence in this Solar System and many others.

David: Do you know how much of our assets are involved in that war right now in the space program sense?

Corey: The assets don't even know that they are assets most of the time. A lot of the people that I've talked to that work in the DIA, the NSA, the DoD . . . only when they get together at a VFW hall, or have a barbecue at another one of their comrade's houses, and they have some drinks, and they look around and no one's around, they start talking about things.

And something that's pretty common and shocked me recently when one of my contacts told me the same story, is that a majority – a large number of these people – have experiences seeing Tall Grays, usually in their bedrooms. But some of them have seen them in broad daylight.

And usually they're standing over their beds holding a long rod with a light on the tip.

And I've heard some of the names . . . You know, there's colonels, generals, admirals. They're all . . . I've heard some of the names that are reporting this – that have reported this.

On some level, people even down on the DoD level are some sort of an asset in this game, I guess you would call it.

I don't know what is being done with them by these Tall Grays, but it's common chatter among them that these Grays pop up – these Tall Grays.

David: Now, you had a trip to Spain recently, and I was very, very concerned about whether you were even going to live through it. So could you tell us a little bit about that trip?

Corey: Yeah, Stacy was very nervous as well. I was invited to go to a conference in Montserrat, Spain, close to Barcelona.

There were concerns because Barcelona was going to declare independence from Spain, or a province there was.

David: Catalonia.

Corey: Catalonia.

David: Yeah.

Corey: There were worries about that, but also after that recent attempt to cause a UFO civil war in the UFO community, and it failed, there were . . . I was told that there were Rothschild components that had put out a “target of opportunity hit” on both you and I. And what that means . . .

David: That's lovely.

Corey: Yeah. Which means that they're not going to come looking for you, but if you happen to walk into their establishment, you're free game, basically.

David: Right.

Corey: And I was over in Spain in an area that . . . It was not exactly an Alliance foothold.

David: And it wasn't even politically stable.

Corey: No, so the Alliance provided security for me. There were a number of people that I didn't . . . that were undercover security that I never knew about. And, you know . . . big-time security.

The Alliance was paying each of these people \$10,000 apiece to be security for me.

David: What would be the difference between that type of security guard and a VIP-like a head of state, something like that?

Corey: These guys do head-of-state security.

David: Really?

Corey: Yes.

David: So at that level.

Corey: Yeah.

David: That's how concerned they were about you being taken down.

Corey: Yeah. They were very concerned. They were very concerned, and I really appreciate the elements of the Alliance that made that possible, because there were a few little incidents we didn't report to people at the conference, because the security guys wanted everything kept quiet.

David: Understood.

Corey: But they were watching this guy and talking about UFOs, and they were thinking it was really pretty silly. One of the times, the apartment that we were staying in was tossed or broken into while we were gone.

David: Really.

Corey: And when we came back, they flipped out. You know, I didn't know these security people, so the first night I put a light bulb on my handle of my door, you know.

We were pretty paranoid that night.

David: The light bulb would fall and smash if it opens?

Corey: Right.

David: Okay. Interesting.

Corey: Right.

David: So were there any signs of suspicious . . . I mean, obviously, you get your whole apartment trashed, but other than that, did you see people that looked like they were stalking you? Anything like that?

Corey: No, not while we were in Spain. But as soon as I landed in the Florida area, on the return flight, I had a number of things occur.

I have video on my phone of two of the guys that were following me.

David: You showed me.

Corey: Yeah. One of them came and sat right next to me. The other one sat a couple seats over. And he had either a Strategic Air Command hat or a SOC hat. It's one of the two.



The Air Force, obvious Air Force guy, and he was older, wanted me to see that he was staying close to me.

This really big guy that I got video of too, came and sat down next to me and was fiddling with his phone a lot, and then he leaned over to me, and he said, "I'm a friendly. The others are not."

And I was like, "others?" I only saw one, and I looked over, and I saw another guy that was watching me quite a bit and kind of wanted me to know, but I didn't see anyone else.

So that was enough to get me completely paranoid. And that was on my flight from Florida to . . . to fly back home.

David: What can you tell us about the possibility that we're finally going to get the truth about the UFO cover-up? Are there steps of progress being made in that direction that you can share with us?

Corey: Well, just the same steps that were going before. These Earth Alliance groups pretty much kind of came to an agreement that there was going to only be a partial disclosure – a partial disclosure of information, and that was going to be what we've talked about – ancient ruins under the ocean, under the ice in Antarctica, and then, "Oh, guess what? We've got this Secret Space Program.

"It's somewhat ahead of time. We can use a type of gravity nullification to fly to a couple of bases in the Moon, and Mars. Oh, by the way, we found ruins there, you know. But it's all ancient. There's nothing new there."

And that's how they slowly plan on, over a protracted period, giving us Disclosure, which is obviously not what we want. We want an immediate Full Disclosure, rip-off the Band-Aid event.

David: Are you seeing signs that the Cabal will not have the power and influence that it does now when those announcements are made?

Corey: Well, the Cabal is seeing that – the signs. There is more and more activity around routing out Deep State operatives, both in the United States, in other countries. It's occurring right now.

And I've given you updates recently about all of what has been occurring with these secret grand juries, you know, a lot of very interesting things going on. They had pretty much come to a conclusion and

were preparing sealed indictments when they just received, very recently, very recently, a treasure trove of other information that's bringing them in all kinds of different directions.

David: So one of the interesting things that you've been telling me about in a very circumspect way, without a whole lot of information, concerns some tangible artifacts that you might have been given that would really help Disclosure move forward.

Could you tell us what those artifacts might be – or objects of some kind?

Corey: Right. I was given some documents a number of months ago – I'm going to be non-specific for a number of reasons here – three documents that were very exciting. They were basically like books, very thick. And they were about things like wormholes and warp drives and different things like that.

And I was very excited, but I was told to sit on it. So I sat on it, and then one of the people I talked to in the Alliance said I should get it authenticated.

David: Uh-huh.

Corey: And they gave me the name and address of a place. It happened to be kind of a pawn shop and a gold and silver exchange kind of a place.

David: Hm.

Corey: I went in, introduced myself to the guy. It was all set up. We went into the back room and sat at a desk.

And he sat there, and he looked over the document for probably 30~40 minutes. I was sitting there for awhile. He was looking. There were document numbers. He was looking at the way things were arranged.

And finally, he leaned back, and he said, "How much do you think this document's worth?"

And I said, "I have no idea."

And he said, "Well, I'll give you half a million dollars. How's that?"

And I was like, that sounds very familiar. I've heard that happening to other people, including **Bob Wood**, and it turned out okay for him, but at the same time, I knew that I was . . . It was tempting, but I said, "No, I can't do that. I've been told that I needed to handle this document in a certain way."

And at that point, he just reached under his desk, and I heard all these like magnetic locks, "pop, pop, pop . . . pop".

David: Oh, my god!

Corey: And he took out a pistol revolver, sat it on the desk, and he said, "You're not leaving here with that document!"

And I turned over the document. I left, was shaking all the way home. I was a mixture of really ticked off, and I was really upset. Freaked out.

I went home. I reported it to aspects of the Alliance in ways that we have of communicating. Then I went to bed.

And that night, Stacy and I, we hear something . . . like a box fall over in the attic. I'm thinking it's animals, squirrels that have gotten in. Told her I'd check it in the morning.

I pulled down the stairs and walked up into the attic, and immediately I saw the area where I had stashed the other two books - the installation pulled up and boxes in disarray.

David: Wow!

Corey: So they were in my house and they took the other two.

David: Do you think that somebody might have zip-lined in off a quiet helicopter – something like that?

Corey: I have no idea.

David: Okay.

Corey: That's scary.

David: Yeah! Big-time!

Corey: Because when you pull down the stairs, the springs on it make a lot of noise.

David: Wow!

Corey: I really don't know how this happened.

David: Wow!

Corey: But it freaked me out sufficiently, and very recently, I was meeting with some Alliance contacts, and they said, "I've got a couple of documents for you, but, be careful how you use them."

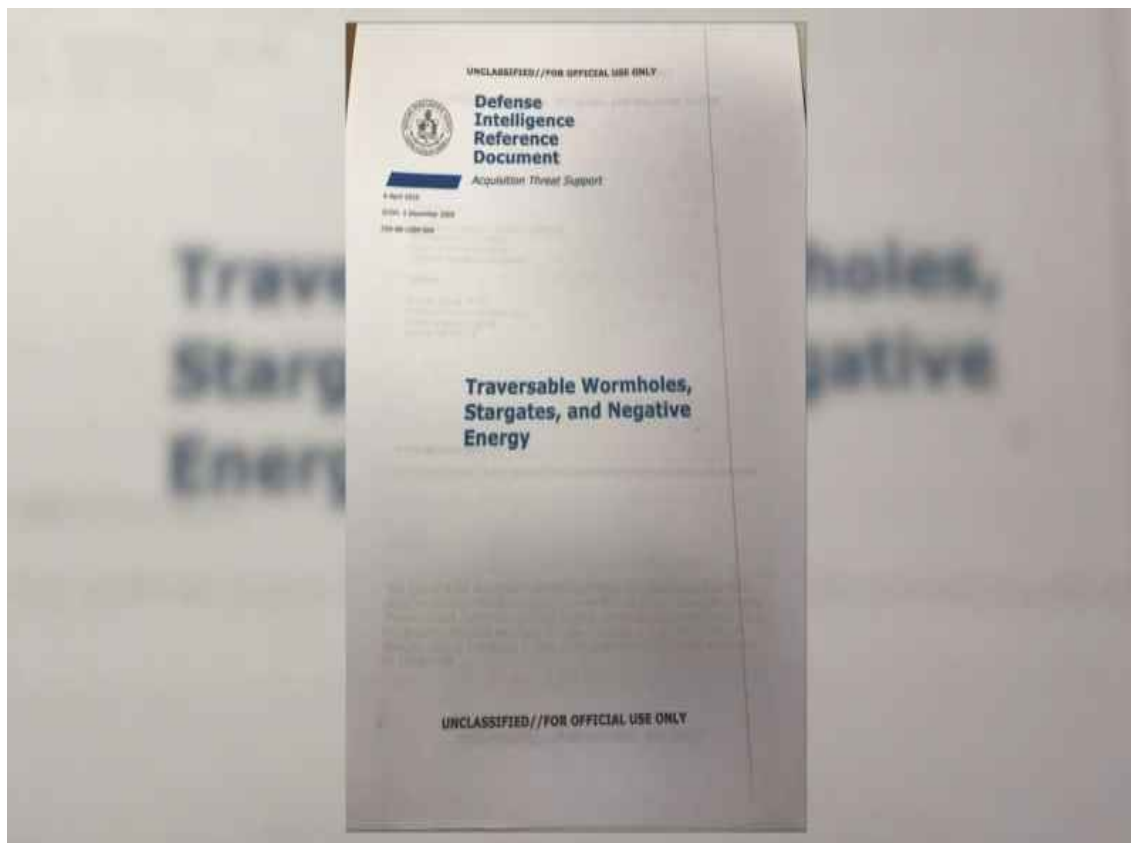

"They are not classified." And they gave them to me.

So I have them. I took them. I have them with me at my house, and they're not classified documents, but what I was told is that I had to reveal the documents in a certain way, with a certain protocol, that if I did that, that the different scientists, engineers and military intelligence folks that had worked in these programs would see that as a sign that it's time to start coming out with some more information.

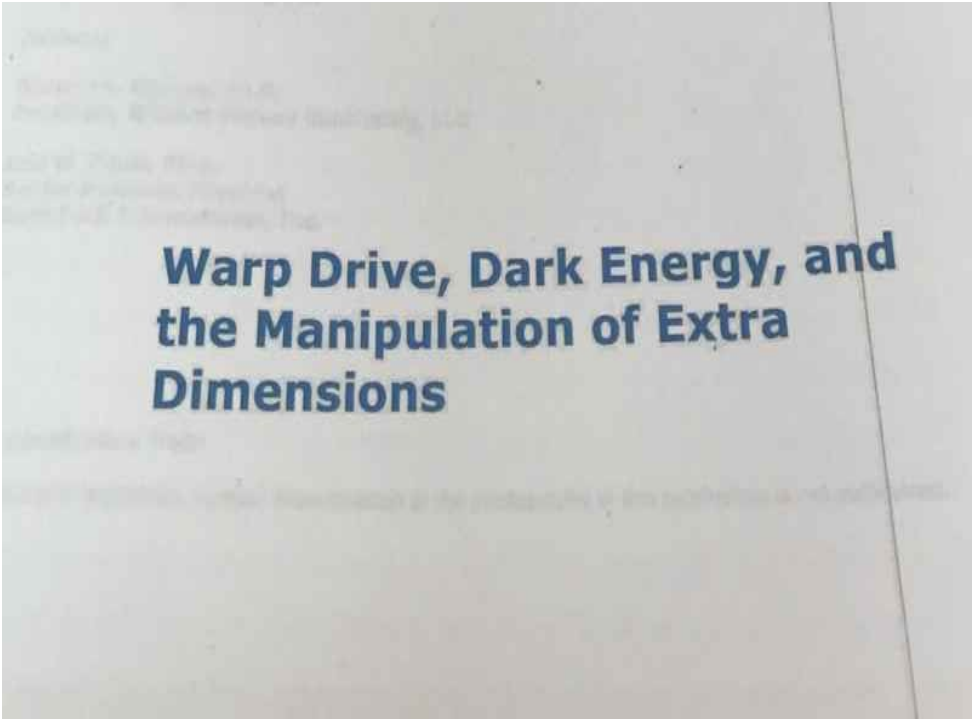

The image shows a document cover with the title "Warp Drive, Dark Energy, and the Manipulation of Extra Dimensions" in a bold, blue font. The background is a light, slightly textured surface, possibly a scan of a physical document. There are some faint, illegible markings and a vertical line on the right side of the page.

Warp Drive, Dark Energy, and the Manipulation of Extra Dimensions

Because these documents, I was told, were documents that all of these people will be familiar with because it was a part of their read-in process.

David: Now, if I can say this, you showed me just some cover pages. And they said they were unclassified. And so the thing that jumped out at me was, to me it didn't seem like they were really that big of a deal because they are theoretical about wormholes, theoretical about portals, theoretical about time travel.

What's so big . . . Why would this guy want to give you five hundred grand for a theoretical document?

Corey: No, those were not the ones that the guy wanted to buy. The ones that the guy wanted to buy were these thick books that had all these formulas in them . . .

David: Oh, wow!

Corey: . . . scientific books that were describing HOW wormholes work . . .

David: Oh, wow!

Corey: . . . not in theory. HOW!

David: Okay.

Corey: That was a book that people would read later on after they were slowly being read into . . . Like an engineer would be given theoretical information to read to percolate in their mind. And then they would be given further information and then fully directed in and read in.

David: So if we eventually go public with these documents, then the idea is that others will now see that as a cue that it is safe for them to talk.

Corey: Absolutely.

David: Very interesting.

Corey: Yeah, and we're looking to start something similar to a Wikileaks place where people can upload documents and doing dead drop mails and a few different ways that we're working to not only protect the anonymity of these engineers and scientists and military types, but to handle it all with the protocols we're asked to do it under.

David: All right. Well, that's all the time we have in this episode of "[Cosmic Disclosure](#)", bringing you updates from the front lines here. I'm [David Wilcock](#) with **Corey Goode**. Thanks for watching.

Cosmic Disclosure: Operation Chaos

Season 9, Episode 4

[David Wilcock](#): All right. Welcome to "[Cosmic Disclosure](#)". I'm your host, [David Wilcock](#), and we are here for another exploration into the far reaches of the unknown with **Corey Goode**.

Corey, welcome to the show.

Corey Goode: Thank you.

David: I want to talk for a little bit about "Operation Northwoods".

These documents were actually approved by the Joint Chiefs of Staff during the Kennedy Administration.

NOTE BY THE SECRETARIES

to the

JOINT CHIEFS OF STAFF

on

NORTHWOODS (S)

A report* on the above subject is submitted for consideration by the Joint Chiefs of Staff.

F. J. BLOUIN

M. J. INGELIDO

Joint Secretariat

REPORT BY THE DEPARTMENT OF DEFENSE AND
JOINT CHIEFS OF STAFF REPRESENTATIVE ON THE
CARIBBEAN SURVEY GROUP

to the

JOINT CHIEFS OF STAFF

on

CUBA PROJECT(TS)

The Chief of Operations, Cuba Project, has requested that he be furnished the views of the Joint Chiefs of Staff on this matter by 13 March 1962.

There was approval for a plan to fake the hijacking of passenger airliners and to blame it on Cuba to create a cause for them to invade Cuba.

UNCLASSIFIED

7. Hijacking attempts against civil air and surface craft should appear to continue as harassing measures condoned by the government of Cuba. Concurrently, genuine defections of Cuban civil and military air and surface craft should be encouraged.

8. It is possible to create an incident which will demonstrate convincingly that a Cuban aircraft has attacked and shot down a chartered civil airliner enroute from the United States to Jamaica, Guatemala, Panama or Venezuela. The destination would be chosen only to cause the flight plan route to cross Cuba.

2. The need for positive action in the event that current covert efforts to foster an internal Cuban rebellion are unsuccessful was indicated** by the Joint Chiefs of Staff on 7 March 1962, as follows:

" - - - determination that a credible internal revolt is impossible of attainment during the next 9-10 months will require a decision by the United States to develop a Cuban "provocation" as justification for positive US military action."

3. It is understood that the Department of State also is preparing suggested courses of action to develop justification for US military intervention in Cuba.

Now, first of all, I guess what I want to ask you is: have you ever encountered "Operation Northwoods" or other plans similar to this within government?

Corey: Similar plans, yes.

David: Well, we actually know the Northwoods documents are authentic. They were formally released by the U.S. government, declassified.

Corey: Wow!

David: Nobody's talked about this.

Corey: One of their quiet releases?

David: Yes. And one of the things that's so shocking about Northwoods is that they openly say that they would use actors, who would . . .

Corey: Crisis actors.

David: Crisis actors who would pretend to have been on the ships, but they're actually CIA personnel, and that they would do what needed to be done, if they were part of a catastrophe, to act out on camera the part that they're supposed to play, . . .

a. An aircraft at Eglin AFB would be painted and numbered as an exact duplicate for a civil registered aircraft belonging to a CIA proprietary organization in the Miami area. At a designated time the duplicate would be substituted for the actual civil aircraft and would be loaded with the selected passengers, all boarded under carefully prepared aliases. The actual registered aircraft would be converted to a drone.

b. Take off times of the drone aircraft and the actual aircraft will be scheduled to allow a rendezvous south of Florida. From the rendezvous point the passenger-carrying aircraft will descend to minimum altitude and as directed

. . . and that CIA employees would be put on the planes as passengers, but that those planes would be replaced with drones that were actually, then, crashed. So the real plane is not used.



Corey: The use of crisis actors is a dirty trick that the intelligence community's been using for a long time, and this has recently come out in the alternative community. So this information coming out is very real and very damaging to them.

David: What is a “crisis actor”, based on your personal understanding?

Corey: People that will come in and, for whatever the crisis is, come in and pretend to be under distress or whatever is called for – even pretend to be injured, pretend to be fatalities.

They were used quite a bit in the FEMA training. When I was in the Texas State guard, for FEMA certifications, joint training between state and local authorities, they would have crisis actors come in.

It's something that's widely used.

David: But these are alleged training exercises which were not being portrayed to the public as real.

Corey: Right.

David: Okay.

Corey: There are a large number of people that are trained crisis actors.

David: Well, isn't it also interesting that a lot of times when these allegedly terrorist events or natural disasters take place, that there seem to be military drills? Like, there were five different military drills on the day of 9/11 involving hijacked airliners.

Why would the Cabal make these drills where they're putting emergency personnel in place when they're going to do something that's going to hurt people and injure people? What's the idea behind that?

Corey: Well, usually, they'll have them there for operational support, if things don't go to plan, or if things go further than they had planned. They're going to have these people come in and restore peace or come in and cover things up.

David: What would be an example of something going further than they'd planned?

Corey: Well, let's say . . . and I don't have information . . . any of the information about 9/11. But let's say that they wanted to just topple one tower, and they ended up toppling both towers, Building 7, and then ended up taking out some other assets that they didn't plan on.

If they were using micro nukes or secret space technology, somehow that kink was exposed in the operation, then these people would move in real quick, media blackout, and find a way to cover it up.

If it goes to plan, then they're just on a coincidental training operation.

David: If somebody sees something that they're not supposed to see, are these teams going to assassinate that person? Would they inject them with sodium pentothal and try to blank out their mind?

What are some of the things that would happen?

Corey: Any number of things. Usually threats are enough.

David: But could there also be . . . You had mentioned in other episodes this blank slate technology. Would some of these people actually have a version of that that they could use if needed?

Corey: Yes, if they needed to, they have plenty of tools they could pull out of their little bag of tricks. But usually, good, old-fashioned intimidation does the job, especially if people have people they love or something to lose, which most people do.

David: What would someone actually say if they were going to do the intimidation? Let's say that I'm the person, and you're threatening me, what would you say to me?

Corey: Well, you're asking me to take a bunch of leaps here, but I would assume that these special access program black ops wet works guys wouldn't mince words. They would get straight to the point and let them know that something very specific would happen to their child – something very disturbing – or someone they love.

Or they could become destitute or be known as a child molester or any number of things.

So the delivery of the threat could be tailored for the person.

David: Are there any training protocols that are used in terms of how to deliver the threat to make it as intimidating as possible? Are there certain techniques to make it scarier that are followed?

Corey: Yes. They will control the environment. They set up everything . . . The whole psychology of the environment: the way they stand, the body language they use, the way they use their voice, the way they have the person sit. Everything is done a certain way.

David: What about the eye contact? Is it like a very intense eye contact – unblinking, unwavering?

Corey: Yeah, it just depends, but they have . . . And it depends on the person – the way the person is acting. They have to tailor . . . It has to be tailored to the person.

David: Something like this Operation Northwoods document, that's extremely treasonous and shocking. Now, we know that John Fitzgerald Kennedy did not approve the plan, but it appears that all of the top-level military brass from each division felt that this was an acceptable strategy to create a war with Cuba, which they wanted to have, but the American public was not hip to it.

Corey: What you need to understand about the people that come up with these ideas, and these think tanks, that these ideas are then submitted to places like the DoD and the State Department. These people believe in order out of chaos.

So they also use chaos to redirect attention away from things.

And we see that very clearly with the refugee crisis that's going on, that's been going on for a while,

that's very much engineered – hundreds of thousands of people from Syria that are flooding into Europe and other locations.

That is the type of plan that comes out of these think tanks.

David: When you say “order out of chaos”, some people would be familiar with the image of an eagle with two heads that is clutching a banner that says, “ordo ab chao”, which means “order out of chaos” in Latin.



Is this a religious belief that these people have?

Corey: Yes.

David: And how far back does this religious belief trace? I mean, Latin would imply Roman Empire.

Corey: It goes much further than that. What do they say? How did the universe come about? Order out of chaos.

They believe there was a great explosion, a great amount of chaos, and after that chaos, order came about, and here we are.

And they have micro and macro examples of that they use in explaining why order out of chaos is the natural order of things.

David: The emperor of Rome, Scipio Africanus, being caught in a scandal where he was bribing the enemy, the leader of the enemy country, Antiochus, with 3,000 gold coins. He got caught.

And he ended up ripping up the books in front of the Colosseum when he was accused of this.

Now, this is like, 200-something BC. But right there, you have a Roman emperor caught bribing the leader of the enemy country that they're at war with.

That implies . . . That's just like one little thing you can peel up the rug on. That implies the Roman Empire may have been actually collaborating with the people they're at war with.

Do you have any evidence of it going back that far, of this kind of treasonous, high-level collusion going on?

Corey: Yes. On a very high level, including a level that is what we would call not surface civilization involved: interference from Inner Earth civilizations and non-terrestrial civilizations manipulating the secret Earth-government syndicates, people that we call the elite or the Cabal, manipulating them. Or these groups looking at these other groups that I just mentioned, ET, Inner Earth, as gods, and carrying out their bidding.

David: Well, now, the presence of the “svastika” or “swastika” symbol all over the world, all these ancient cultures have it.



And that would imply, since a lot of these lands are warring with each other, the swastika group, which was one of the more negatively-oriented groups that you met down there, has been meeting with all these different folks that are at war with each other and presenting themselves as gods, but they're actually helping both sides of the war. Would you say that's true?

Corey: Not necessarily helping both sides of the war. Usually, when the manipulation was going on, it was us on the planet being a proxy or kind of like a game of chess. We're pawns. And they are playing from the Inner Earth against non-terrestrials that they call the genetic farmers.

It is a very complex game or war that they're . . . a non-hot war that they're fighting with each other, using us as the pawns. And our kings are the ones that they've been in contact with.

And our kings are the ones that have been indoctrinated and instilled with all these belief systems, such as the . . . you know, you get . . . you create chaos, and then you get order. And they use these tactics on us pawns, or the population.

David: So this would take the form of these, in some cases, Aryan-looking humans appearing in the office of the king, in his royal chamber . . .

Corey: Yes.

David: . . . just popping in there?

Corey: Yes.

David: Which would be very shocking!

Corey: Yes. There is . . . Among the conversations I had with Ka'Aree from the Anshar, they've appeared with people making decisions throughout history – appeared and guided them in making decisions, including with our own . . . beginning of our own United States.

David: This is kind of a ridiculous question, but when you illustrated your meeting with them in the temple, they were all wearing robes. Are they going to appear in front of these kings in robes, or what type of clothing might they be wearing?

Corey: I could not answer that question.

David: Okay.

Corey: Yeah. I had the mind-meld with Ka'Aree, and she was meeting these different people. She wore several different skintight suits of different colors. They may appear in that type of garb instead of the robe.

The robe, it was more of a ceremonial thing that was related to the temple complex.

David: Are these like a single, solid color – the jumpsuits?

Corey: The jumpsuits? Yes, they were.

David: Okay. What are the colors that you saw?

Corey: They were varying shades . . . two varying shades of blue and a yellow one.

David: Okay. So getting back to . . . Let's go back to the major wars in Rome before it collapsed, which would be the Punic wars, kind of like the equivalent of World War I and World War II. They're fighting

against Carthage.

Is there reason to believe that Rome and Carthage at the highest levels were, in fact . . . that the leaders were talking to each other, secretly meeting with each other, and coordinating these wars, somehow?

Corey: Let me put all of this in a nutshell for you, and you can apply that to any war, conflict and situation you want to.

Yes, every single situation has been manipulated from both sides by an unseen guiding force that has evolved into what we call “the elites” now. And it's more formally known as a secret Earth government and their syndicates.

But throughout the past, before they were more organized, they had different agendas, but they still had the power, and they still had the access to these Inner Earth beings and non-terrestrials, and the information from these beings, and were following the agendas being given to them by these beings.

David: How could the generals go out there on the battlefield and risk their lives if they know that this is fake?

Corey: The generals don't know.

David: The generals don't know? But that's the highest level of the military, or pretty darn close, depending on the level of the general.

Corey: The generals are normally given an objective, and then they come up with the tactics and then delegate the rest of the logistics down to the ranks.

The people in control back then, whether it was a priest caste, royalty, what have you, that was where the orders and the information was coming from most of the time.

Now, were there generals, were there certain people, that had contact with these beings and were out making these decisions and doing things AROUND their leaders? I'm sure there were cases of that.

And some of these people probably then became king.

David: When we're looking at the history of things like the Spanish-American War, we have the sinking of a ship. When we look at the origin of World War I, we have the assassination of Archduke Franz Ferdinand, the leader of Austria.



When we look at America's entrance into World War II, we have the bombing of Pearl Harbor.



We have the incidents in Vietnam that brought us into Vietnam.



These sparks, they seem kind of suspicious, don't they? Like the catalyzing event that throws somebody into war.

If what you're saying is true, are these catalyzing events manipulated? Are they programmed? Are they scripted somehow?

Corey: Yes. Every single one that's happened, and any one that would happen in the future, very few wars have genuinely happened over misunderstandings. They've been manipulated by a higher power.

David: Is there some kind of energy benefit that negative beings get from creating chaos? Does it form a sustenance for them somehow?

Why would they be so interested in creating what we would think of as the most unpleasant things that could happen on Earth?

Corey: Well, it depends on the being. Of course, there are beings that vampire the negative energy “loosh” that we're talking about, but it's not ALL about that. It's about control.

It's about a chess player that thinks 50 moves down the road, and they're manipulating and making . . . psychologically working against their enemy to make sure that that 49th move is still going to be viable.

This is more complex than just etheric beings wanting to suck our energy from us. That's a big part of it. That's occurring.

But there's layers to the onion, and some of these beings are just using fear, chaos to distract us from what we need to be paying attention to, or in some cases, they're convincing the humans that follow them that if they create chaos, order will come from it because that's the natural order of the universe.

David: Well, we see things like the Spanish Empire, the Ottoman Empire, the British Empire, where relatively small countries end up building a massive amount of power by overtaking other countries – the Roman Empire being another example.

Is this empire-building part of the goal? Are they trying to dissolve nationality and national boundaries?

Corey: Different groups have had goals of creating a one-world . . . I guess, not really a one-world government, but all these different groups that have controlled different areas of the globe, or different populations of the globe, have wanted to expand that power and control everything and push their enemies off the globe or underground.

David: So that's the “New World Order”?

Corey: Yes. That one particular scenario would be the “New World Order”.

David: So when they say, “New World Order”, is that word “order” the order out of chaos that they're trying to create?

Corey: Yes.

David: Why would they need to have every country under their control? Why wouldn't it be beneficial to them to have people that were still opposing them?

Why would they want to own and control everything?

Corey: Until you logistically can control an entire planet, you want to have the entire planet at each other's throats. There's all these different groups that have different agendas and ideas. Some of them want to do population reduction.

I mean, there's many different agendas. And the ones we hear most about are the darker agendas of bringing the population down to 500,000, I think it is, and . . .

David: The Georgia Guidestones.

Corey: Right. And different things. But there are a lot of different agendas and plans out there.

David: Let's go with the Georgia Guidestones. It looks like Stonehenge.



It's sitting there in Georgia, modern times. It's got these precepts that are carved in multiple languages, and the first one says to maintain a global population of 500 million or less.

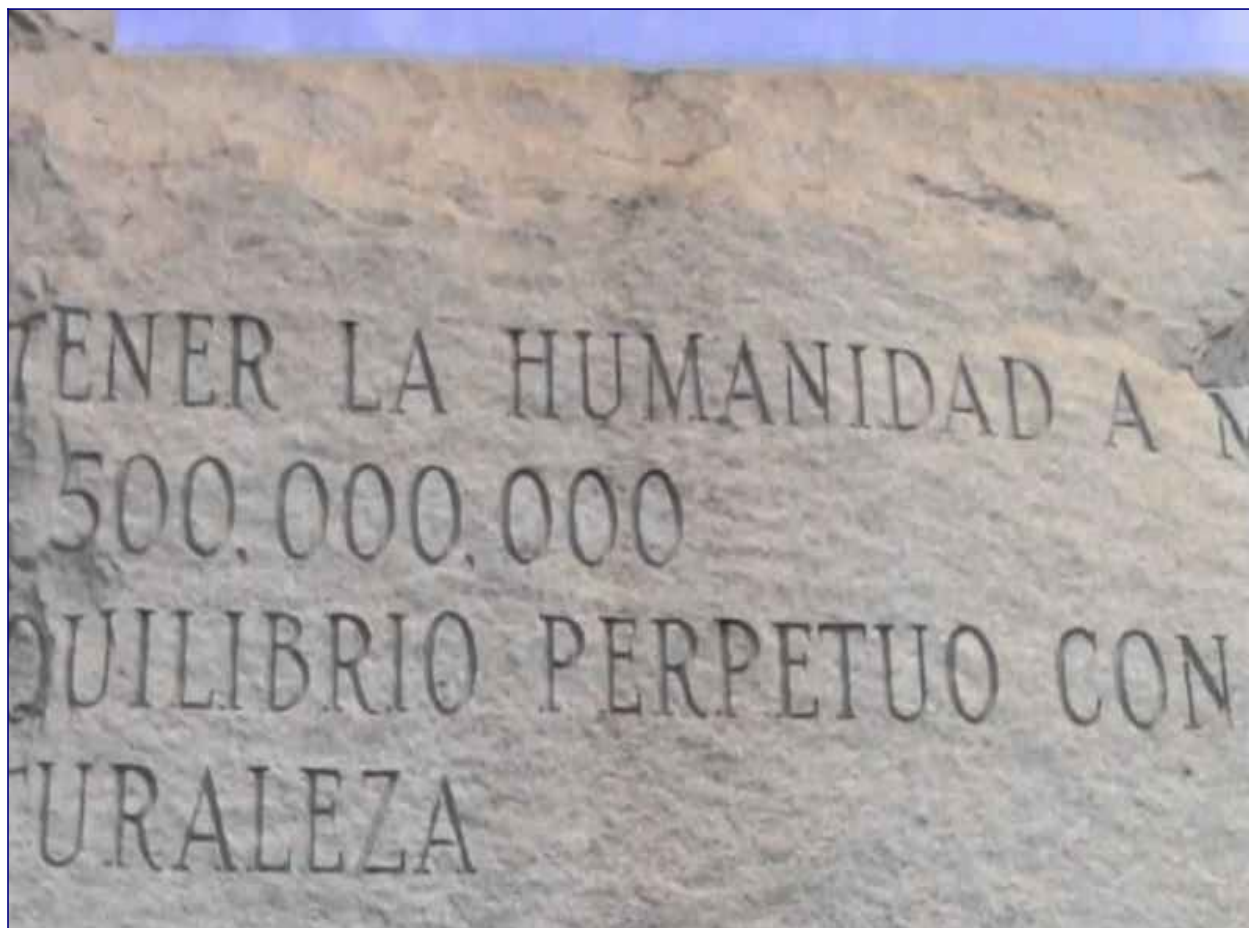

Why do they want to get rid of so many people? This just seems completely outrageous. It doesn't make any sense at all. What's the idea here?

Corey: What is the true reason they want to do it is really the good question. They say it's because the Earth cannot sustain more than that the way we live.

David: Humans are “bad” for the environment.

Corey: Right. But what actually do they have planned? Why do they want to free up so much real estate on this planet?

There were some of these New World Order groups that were making some dark deals that were planning on giving away entire continents to non-terrestrials. And some of those groups already have built embassies on those continents.

It doesn't look like those "land deals" will be going forward now, but those were just some of the things that were going on.

David: So there are treaties in place with certain ET factions . . .

Corey: Multiple.

David: . . . and they . . . Are they homeless? They don't feel like they have a home planet any more, and they want to be here?

Corey: There are groups that are very advanced that can sustain themselves almost indefinitely in a space environment that are, basically, in a refugee status, that would like to be in this coveted Solar System.

And there's obviously a lot about these different groups that we don't know.

It doesn't sound like someone we want to live on the planet if a part of their negotiation is to reduce the population by such a large amount.

David: Well, one of the things that other insiders told me is that some of these people can't breathe our air, that the air needs more oil in it.

Corey: Right. Not exactly terraform. I can't remember what they called it, but it was a modification of the environment. Something about the nuclear radiation was going to have a byproduct on the environment that was more conducive to one of these species.

David: Like they have a radiation-hardened body, and it's actually better for them.

Corey: Maybe. Or it seemed like the radiation was going to have a long-term later benefit for them or something.

That is something that . . . I mean, I read that over 20 years ago. So there is . . . I can't remember the specifics on a lot of those individual plans.

David: So what . . . You may not be able to answer this, but what percentage of the people who are actually working in the Cabal are aware that they are being used by extraterrestrials who are trying to terraform our planet?

Corey: I would be totally speculating, but it seems like a large number of them that have been coming over as material witnesses in this off-planet witness protection program now quite a bit, but they didn't know all the details.

And what a lot of what made them flip is hearing more details from information that's been released that scared the crap out of them.

These people have also had to deal with these Cabal groups cleaning house, worried about people testifying against them, having too much information, you know, too much knowledge about their dealings.

So if there are Nuremberg-type trials, they figure, if we take out all the witnesses, we don't have anything to worry about.

David: Do you think that the Cabal could be trying to deindustrialize the West?

Corey: Oh, absolutely. Yes.

The whole point is you take an industrial nation and move their jobs and that industrial ability over to a nation that's a third world nation that can do it cheaper, and weaken that industrial nation that just so happened to have won two world wars and has been called a sleeping giant in the past, and if awoken, could cause them problems again.

Even though they control it, even though they control it, they still need to manage it and keep it weak.

David: Why do you think so many of the people who write about this stuff online actually seem to worship the Cabal with their fear, that they see this as a towering enemy that has no possible solution?

Why do you think we, in general, seem to believe this group to be supernatural and so powerful that nothing can be done?

I mean, people are going to feel hopeless when they hear you tell us this stuff.

Corey: Because we buy into their propaganda. They've infiltrated the ufology community from the beginning, and they plant these seeds of hopelessness that they have all the power. They cannot be defeated. They are supernatural.

They put in all of these different stories to make you think you have to kill them with a silver bullet, and there's no hope, when we actually have all the power.

David: Well, it's nice for you to say that. It's like putting a little doily out there on the tabletop.

Corey: That's not a New Age platitude. That's . . .

David: But the people watching the show need you to tell them why they're still going to want to get up tomorrow morning and go to work, because what you've said is extremely disturbing.

Corey: It is.

David: How do we stop these people? How do we just . . . because people are going to think that this thing just has been going on for thousands of years. It's just going to keep going. What do we do?

Is there anything WE can do? Or is there anything being done about this?

Corey: When you say this, it reminds me of a kid's movie, an animated kid's movie, called "A Bug's Life", where ants are being dominated by these grasshoppers that come in and take all their food.

There's the leader of the grasshoppers. His name's "Hopper". And the other grasshoppers are like, "Why do we need to go back? Why do we need to go back to these ants? We don't need their food." And, "Just one of them stood up to us. It was just one ant."

Then the scene occurs to where he shows the power of one ant.

David: We have power in numbers, don't we?

Corey: Right. It's time for the ants to rise up against the grasshoppers.

David: Would you say that people educating themselves is a very important part of that process in educating others?

Corey: Yes. And then starting to spread that education to others through some very uncomfortable conversations.

David: So would you say that this is ultimately going to be a grassroots effort that just involves each of us having more courage and speaking to people in a non-threatening way who may not already be convinced about this stuff?

Corey: It's a good start.

David: All right. That's all the time we have in this episode of "[Cosmic Disclosure](#)". I'm your host, [David Wilcock](#), and I thank you for watching.

Cosmic Disclosure: Undersea Bases

Season 9, Episode 5

[David Wilcock](#): All right. Welcome to "[Cosmic Disclosure](#)". I'm your host, [David Wilcock](#). We're here with **Corey**, and in this episode, we're going to go into underground and undersea bases.

Corey, welcome to the show.

Corey Goode: Thank you.

David: Some people, in fact, probably many people, are familiar with this strange image that's been circulating around on the Internet forever of this very large tunnel-boring machine that says "US Air Force" on it.

It's all white, and you see these guys next to it, and they are dwarfed in size by this thing.

What is that machine? Are they able to dig tunnels underground? Is that what that is?

Corey: Yes. It's like a mole, boring machine, a nuclear tunneling machine that crushes and vitrifies the rock as it goes.



They have different sizes and types, but I believe the one you're talking about, the gargantuan one, creates huge tunnels through all different types of rock for as long as you want them to go.

And they're created tunnel systems that circumnavigate under the oceans from continent to continent.

David: So just to break into this a little bit, do you think that underground cities are being made? Do you think that they exist?

Corey: Ha, ha.

David: Ha, ha.

Corey: I know it. I've seen images. I've seen video. If you were to see the video of some of these places, you would think you were looking at a luxury mall or hotel in Dubai. They are very futuristic-looking.

A lot of the times, in the middle, for at least sections, there's wide open areas with, on the outside, along the outside border, will be the beginning of where you enter into the complexes, and then they'll go further out into, I guess, what used to be a cavern wall that they built.

And the images that I saw took almost looked like they were taken from a drone going down, and you

could see curved, huge elevators. And this is the kind of thing that they would show people that they wanted to get into the Secret Space Program to tell them, “We have bases off-planet that are as advanced as the Jetsons.”

These are obviously built for the elite. The military bases are much more spartan, and when you're in them, you wouldn't know much of a difference than if you were at an above-ground base.

David: Well, it sounds a little different, what you're describing, than I think many people's perception would be.

I think if most people would think of an underground base, then they would imagine that a certain amount of ground is carved out, and that ground is the building. So all you're going to have is rooms and hallways.

Corey: They have those as well.

David: They do?

Corey: Yes. A lot of them are laid out in a way that are very long, narrow corridors that are carved out and that will be side by side, or a few side by side, and a few turned the opposite way – I guess perpendicular.

And then we'll have the same amount going that way, in the opposite direction, that will be connected. But those are the ones that are usually not that far underground and are usually directly underneath some sort of already existing base or other structures.

David: Are these always drilled out of the ground, or . . . ?

Corey: No. Over the years, they've used many different ways of doing it, from using conventional or . . . I guess the original type of nuclear explosions to blast out cavities that would vitrify a lot of the rock . . . A lot of it would collapse back in. They would go in and clean whatever out that they needed and then finish it off.

David: So just a typical nuclear bomb underground? They'll hollow out a large cavity, even if it's all solid rock down there?

Corey: Right.

David: Okay.

Corey: And then a lot of times, they would just drill really deep holes, put in charges of high explosives, things that detonate at well over 32,000 feet per second, that just turn the rock to dust, no matter how hard it is, and then they excavate it.

And, of course, you have the tunnel-boring machines. And then up in recent times, they have more recent, next-gen type of explosive devices, that when detonated, leave a lot more desirable, almost spherical hole in the rock, that also has almost no radiation.

David: When are you aware of these underground civilizations, underground bases first being constructed?

Corey: We've been building underground bases since before World War I that are . . .

David: Before World War I?

Corey: Yeah, that were pretty impressive. But that's when we were really learning. It really didn't become a real pressing matter to have deep, underground military bases until the nuclear age, and until the age of having not only nuclear weapons but delivery systems that were sort of like bunker busters, that could deliver nuclear weapons deep under the rock strata before detonating.

So they had to keep up with the weapons systems that were being developed. As the weapon systems were being developed to take out deep, underground military bases, the deeper they went, and the more sophisticated they became.

David: Isn't there going to be a problem regarding the Earth's crust getting hotter as you go farther down? How do they circumvent that?

Corey: They do have environmental control over the . . . These are closed systems – all the air, everything. They're closed systems.

And in a closed system, you can pressurize it and control the atmosphere.

David: So you're saying that some of the ones that our own people have built have actual buildings in them like you're looking at a city?

Corey: Some of the ones that were actually built as cities, underground cities, for what we call the elite and their families to escape to.

David: Do they have like what we talked about with some of these Inner Earth civilizations? Do they have trees down there, and lakes and rivers, that kind of stuff, as well as buildings?

Corey: They do hydroponics. They also have plant life to help do some sort of balance with scrubbing CO2. And also with their water systems, . . . It's a closed system, so they do have that kind of thing, but I do not know the breadth of it.

David: How do they find a water supply? Are they able to tap into aquifers or underground rivers?

Corey: Yeah. The problem is keeping the water out.

David: Really? Let's go now to Phil Schneider, who is a whistleblower who came out about, as you said, Deep Underground Military Bases, or D.U.M.B.s, . . .

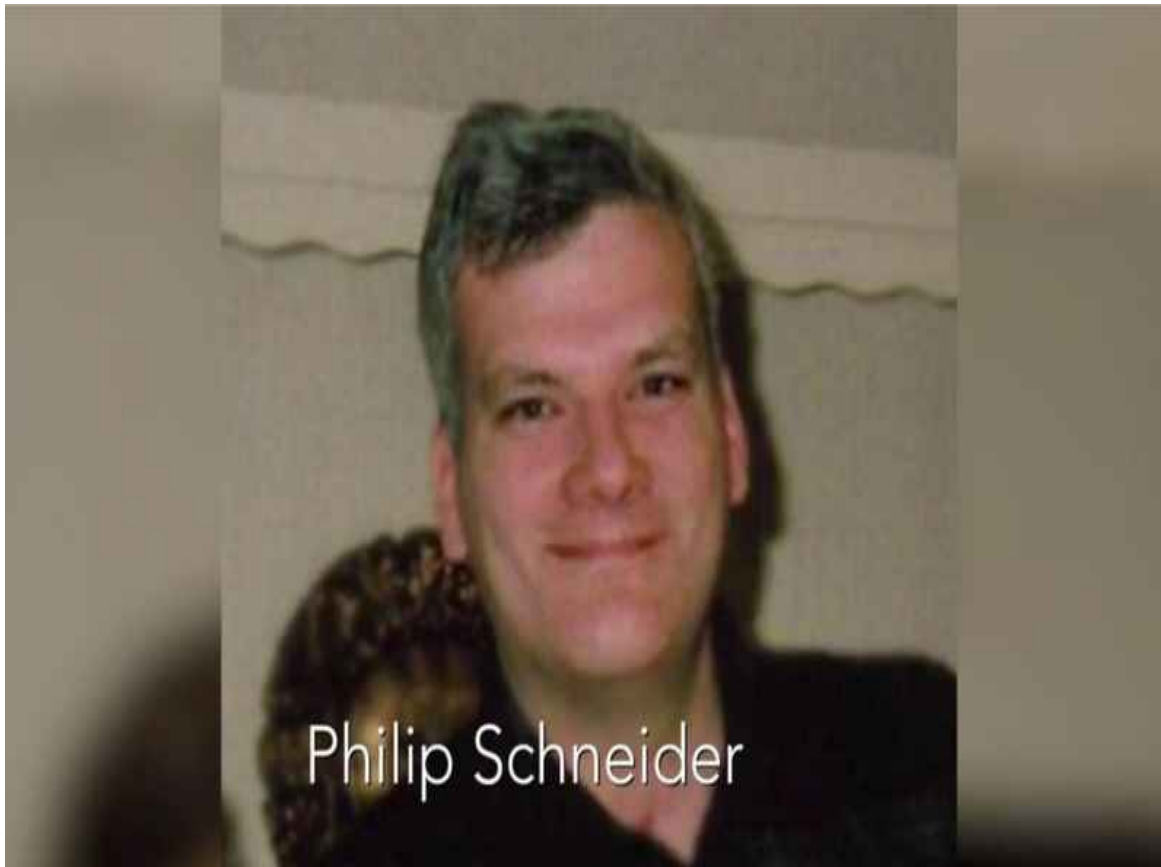

Corey: That's extremely incomplete.

David: You say that's extremely incomplete?

Corey: Oh, yeah.

David: Okay. Why would you say it's incomplete?

Corey: Because the underground tram system goes under the ocean. It goes to Australia. It goes to Europe. It goes to Asia. The tram system travels all over.

And there are underwater bases. There are bases that are underwater, on the surface of the ocean floor, and there are also subterranean bases below the ocean floor.

David: Well, some people might have trouble with that because normally just getting a submarine down there, like a bathyscaphe, or one of these things that they would use to try to film the ocean floor, the pressures become extremely great as you go farther and farther down, from all the water that's there.

Corey: Hm-mm.

David: So based on your understanding, how have they surmounted these problems to make these undersea bases?

Corey: The type of base that I'm going to tell you about right now, you're not going to really find in the Marianas Trench, not built by us, anyway.

But I had an engineer describe to me how they built a certain base with domes that were lowered into the water, positioned by the Navy, and then an underwater concrete was applied.

The domes were placed on top of the foundation, and then the water is pumped out from the inside of the dome. And then the pressure of the ocean creates an even tighter seal from the way it's engineered.

It's a type of concrete that is the foundation. They enter in below and come up within.

And these aren't huge domes like you would think of in sci-fi, but they could be colonies of domes that are connected together.

David: And what is the dome material made out of? What does it look like?

Corey: Some sort of . . . I don't know if it's acrylic or plastic of some sort.

David: Does it have any transparency, or is it solid?

Corey: It's kind of an opaque.

David: Okay.

Corey: And then they build within it. And then, again, there is [are] also Navy expeditions that have gone and found beautiful underwater caverns that lead to areas underground that are perfect for sealing off and pumping all the water out, pressurizing, and building a base.

They've done that and created several submarine bases.

There's one that there was a lot of speculation about. Some people said it was a hoax, but there is an opening for an underground base system that submarines use off the coast of California that was, I believe, caught on a satellite image. And there was a whole lot of scuttlebutt on the Internet about it, and then it kind of died off.

There was a door that would normally be closed that matches the features of the ocean floor, and it was wide open, and this is where submarines go in, go to a lake that is in Nevada or . . .

David: I thought it was Nebraska.

Corey: Yeah, Nebraska.

David: The "Nebraska Navy".

Corey: Yeah. Yeah. And it pops up in a . . . And they pop up in a lake, or they'll stay just below and not surface. But they have . . . It's large enough for nuclear submarines to travel in a subterranean cavern system. It's like an underground submarine . . . and underground, underwater submarine base.

David: Well, let's just speak in generalities now, because I think the answer you're going to give is quite shocking.

How many bases underground or undersea have we, in our modern civilization, built that you're aware of?

Corey: Oh, anywhere from very small ones to very large ones, it's hundreds – hundreds of them. And as we build bases or are tunneling for bases, we come across many ancient underground bases from other civilizations, or current bases from non-humans.

So there's a lot going on down there. There are a lot of different types of bases, and there is some prime real estate below the ground to do things secretly. And all the beings that are doing secret things, including our Special Access Program people, are down there doing it.

David: How could they possibly pay for such massive construction programs?

Corey: You're assuming that they're going to the DoD, putting in a cost, expense, expenditure plan and getting it approved, and then going and taking that money out of the budget and hiring this contractor and that contractor to come in and do all this work, and then paying them with a check.

Everything that is done is done with either . . . if it's done with the lower space program or military intelligence, it's done with drug money, money laundered from some other type of illegal activity, or it is done with misappropriated funds from other things, like maybe Social Security.

But they find a way to make things happen when they need it.

David: When we're looking at the kind of labor that would be involved in building skyscrapers, we're talking about tremendous numbers of contractors, tremendous amount of logistics and support, bringing in all the building materials, the construction materials.

Is there some kind of vast, underground infrastructure of workers who just live underground that would be available to build new things like this? Because obviously, if they are building this stuff underground, and they are using people from the surface, that creates an operational security issue, I would think.

Corey: Right. A large group that do . . . they maintain the underground systems, and the people that build them, well, they don't . . . they live down there pretty much when they're building it, but they are not sequestered down there.

They are a part of this military-industrial complex and are heavily rewarded for the work they do.

Now, if these people were all sequestered down [there], and the security procedures were taken to where we never saw or heard from any of them, we would know nothing about these bases.

David: Is this something that's primarily being done by the Cabal-controlled countries, or are there other countries that are less Cabal-oriented, like, let's say, India or China, that are doing this as well?

Corey: Just about any country you can think of is doing this on some level.

David: Are these countries that are not part of the Cabal, are those bases disconnected from the Cabal bases?

Corey: Absolutely.

David: Okay. So it's not like they're all tunneled together.

Corey: No, they're self-contained. No, these are . . . Yeah, most of the bases are self-contained. There's only a few that are . . . I mean, not a few, but a small percentage, that are a part of this underground network – a small percentage, globally, of them all.

The vast majority of them are built to be self-contained and to house a certain amount of people, anywhere from 10, 20 to 100 years, and sustain them.

David: Hm. What do they use for power to run the electricity down there?

Corey: Well, some of them use geothermal power, and some of them use hydrodynamics, and some of them use classified power systems.

David: Hm. It would appear that there would have to be a decent number of people who are living down there on a continual basis in order to keep this whole infrastructure going.

Corey: Yeah. And they see that as a golden ticket if there's a catastrophe above ground. And they're not going to jeopardize that if they think that . . . If they have a golden ticket for them and their family, to bring their family down, the last thing they're going to do is jeopardize their family being left on the surface during some sort of a catastrophe.

David: Are there people who have been down there for generations, and they've never gone back to the surface?

Corey: That is mostly the case, I've heard, on off-world bases.

David: How many total personnel do you think there are that you know of?

Corey: There's no way I could even guesstimate, but there's more now than ever. All the intelligence that's been coming in – I guess we'll go with the Cabal term – Cabal groups have been moving supplies, tooling, military assets, personal items and family to these bases.

One of the most advanced bases has been built down in Brazil. It is one that there's been a lot of activity, a lot of shipping containers, a lot of supplies, a lot of personnel moving down there.

This has been reported by several different sources, and it's been going on for well over six months.

David: Have you heard any intel on your own about some of these bases having a vulnerability or potentially being portalled out or otherwise destroyed in some way?

Corey: Yes. There have been some of these bases that have been attacked, some of the older bases or bases closer to the surface.

This is why they have put so many resources into building these more advanced bases, like the one I'm talking about in Brazil that I've heard referenced as a “Zazi base” and a few other terms. So it's definitely a Cabal, Nazi-type, fascist regime base.

David: Zazi is similar to Nazi, so . . .

Corey: Yes, it's when the groups moved down to South America, they started going by business names. And business coalition groups, they started going by “Zazi”, and they were all . . . they all happened to be Germans with ties to Nazi Germany.

David: Are you aware of any extraterrestrial groups from your time in the space program that would have a sufficiently advanced technology where long, straight, shafts like this could be built with exceptional ease, much more than what we're doing with these nuclear-controlled drilling tuber systems that we have?

Corey: Yes. These ET “embassies”, as the space program is calling them, are diamond laser-cut-looking and symmetrical and were built in almost no time.

David: So do they have a way of getting rid of the material, so they don't need to just be hauling it out of there?

Corey: Yeah.

David: Is it something that gets rid of the rock?

Corey: Yeah. Once you get to a certain stage and understand everything is vibration, it's child play for them to manipulate matter.

To us, it's a real mind-bender to try to figure out how that magic works, but to them, it's . . . They understand that like we understand how the tides work on the planet.

David: How many of these hundreds of bases that you talked about have extraterrestrials in them as well as humans? Are they primarily ours, or are they also jointly owned and run at times?

Corey: Of course, some of them are joint-operated. I don't have that information. I know that the majority of them are for R&D.

David: One last thing I want to get you to address right before we end the episode here is: people all over the world are hearing these very scary, deep, resonant, trumpet-sounding noises.

And I've had insiders like Jacob, from the space program, tell me that there are these air apertures on these underground bases, and they can partially open them or close them and then ventilate air through them, and it's like blowing into a trumpet and getting this big, resonant sound.

Do you know if they do have these iris-type of metal things that could be used like that, that open and close for air ventilation?

Corey: Every once in a while, they purge the air from . . . they recycle the air. But some of these trumpet noises people are hearing on a wider scale in the skies are actually an energetic shock wave coming from the Sun, causing a . . . not really a sky quake, but the sound is coming from energy coming from the Sun interacting with our upper atmosphere.

David: Do you know if there could be a way that ventilating the air out of an underground base could cause that trumpet sound?

Corey: It does. It causes a real weird sound, almost like a tornado siren.

David: So you're saying that these sounds could be the result of air being ventilated periodically from these underground facilities.

Corey: Right.

David: The metallic shaft is vibrating.

Corey: Right. They recycle air from time to time.

David: All right. Well, thank you, **Corey**. This has been a very fascinating episode. I hope you've enjoyed it. This is "[Cosmic Disclosure](#)". I'm your host, [David Wilcock](#), and I thank you for watching.

Cosmic Disclosure: Technologies of the Secret Base

Season 9, Episode 6

[David Wilcock](#): All right. Welcome back to "[Cosmic Disclosure](#)". I'm your host, [David Wilcock](#), and I'm here with our special guest, **Emery** Smith. And **Emery** has some absolutely stunning information, and he has taken great risks to bring us what he's going to share today.

Emery, welcome back.

Emery Smith: Thanks, Dave. Thanks for having me. I really appreciate being here.

David: It's good.

Emery: Yeah. It's fun.

David: I'm really glad you finally decided to do this. I think it's long overdue.

Emery: I know, you've been trying to get me to do this for 10 years, but certain recent events have persuaded me maybe it's for my better safety that we do this, and also to educate the public, and people deserve to know.

I've believed that my whole life, but I know there's also a time for everything.

David: Yes. Now, it seems with a lot of the insiders I've spoken to, that once we dig into their life before the military, that there was something going on before they ever even went in.

And I'm curious: have you had unusual experiences prior to military service that you think may be relevant to share with us today?

Emery: Absolutely. It's personal, but I can tell you right off hand that my grandfather was in the Army, and my father was in the Navy, but when I was born, he was already out of the Navy. And I always wanted to be in the military.

I think I had my first extraterrestrial visit in 1979.

David: Hm.

Emery: And it was at our five acre farm in Fort Myers, Florida. And that was the first contact I ever had, and it was a very pleasant contact. I'll never forget it.

I was not contacted after until 19 . . . between . . . around 1999, '98, where it was like a complete landing and . . . That one was a little bit startling because I was camping out and wasn't ready for it, because it startled me at night because I had just laid down, and I heard some footsteps walking up.

So that turned out . . . That was like the two experiences. The other one's after the military, by the way, but it was just a little bit shocking. But the first one was when I was very young.

But after that, I was obsessed with, of course, laying under the stars. I probably slept more outside of my house than I did inside the house, gazing up at the stars.

David: Could you tell us a little more about the contact in Fort Myers, Florida? Was there a craft that you saw that landed and then what happened? Describe the craft. Describe exactly what happened.

Emery: Exactly what happened was, I had laid down to go to sleep in my sleeping bag, and when I looked up, . . .

David: You were outdoors?

Emery: I was outdoors. Yeah.

David: Okay.

Emery: We had a big farm out there.

David: Okay.

Emery: . . . in the middle of the field. In the middle . . . You know, there's nothing around.

And, you know, a flaming disk comes very . . . a 45° angle. It just comes right out of the sky but moving VERY slow, but red hot.

You could see the orange glow.

David: How large was it?

Emery: Well, from where I was at, and it was probably at least 2,000, maybe 1,000 meters away, and I saw it go into the woods. And I heard it. And I said, "Oh, it was probably just a meteor." And wow, it was like the most brilliant meteorite I'd ever seen. But I also noticed that it had a very odd shape.

So I just didn't think anything of it. And it actually landed closer than I thought: in the neighbors, just a couple acres over, 5 or 10 acres over, in their swamp.

And one of the extraterrestrials came out and walked over. And I was next to a barbed-wire fence – you know, the one you keep cows in with, four lines, sometimes five if they're big.



David: Right.

Emery: I used to put up fences. You know, these little hooks that you put that barbed-wire fence . . . you know, but that nail to hold the barbed-wire fence against the pole, right, that little hook?

David: Uh-hm.

Emery: So some of them were kinda loosened, you know. And I laid out a tarp all the time. And then I put my sleeping bag on the tarp.

So I laid down, and I'm in the bag, and I always . . . you know, being who I am, tactical **Emery**, I always have my gun with me. I did have my gun with me in my sleeping bag. And I was in a mummy sleeping bag, and it was very cold.

And I heard a, "Ugu, ugh", like someone jumping the fence – just as if I would climb the fence. And as the fence gets pushed down, it goes to the metal in the hooks . . .

David: Right.

Emery: It's like, "Ur, ur, ur," and then "bump, bump" on the ground. And I'm like, "Okay. All right. Skunk ape, bear . . ."

David: Ha, ha, ha.

Emery: ". . . panther?" Ha, ha.

David: Ha, ha, ha.

Emery: And I'm just like, "Oh, right now?" Immediately, I'm listening to the footsteps. And I'm very attuned to that kind of stuff.

David: Sure.

Emery: I felt a little like uneasy. So I know, maybe it was just me, or maybe it was this being. So I immediately just grabbed my zipper, and I already had my gun in my hand, and I unzipped, and with my gun and flashlight just stood up, and there was a three-foot being right there looking at me.



David: What did it look like?

Emery: It was blue-gray, and it had big blue eyes. And it had a little thing on it's head like you see in the movies, like we see in cartoon characters.



David: Like an antenna?

Emery: Yeah, a little like an antenna.

David: When you say it had blue eyes . . . So we're not talking about a Grey?

Emery: No. No. It was very scrawny, and it was blue. And it . . .

David: Like what color blue? Like your shirt?

Emery: Yes. It was this kind of blue. And with the light on it, and me, I'm still stuck in my sleeping bag, and it looked at me, and I think the light really hurt its eyes.

It got like, “What, huh, oh! This is not going down right.” Or, “Huh, oh, I just crashed my craft. I'm just looking for the nearest help or assistance.”



So it's embarrassing to say, but I jumped up out of the sleeping bag, and I chased . . . because I see him walking . . . going [showing running with small legs] . . . and I'm chasing him, and he goes into this thicket.

And I'm not, you know, like chasing him to kill him. I'm just like, “Come back! Come back!”

David: Ha, ha, ha.

Emery: I'm chasing this thing, and he goes right through this thicket. It was so thick there's no way I could . . . I tried to go in there and got all cut up by the vines.

David: Oh!

Emery: And then I hear, “Ur-ree, ur-ree.” And I look next . . . the fence is right next to me. And it gets really tight. Like he's over there jumping the fence again, heading back . . .

David: Oh!

Emery: . . . to that area. So I was full of adrenaline. And, of course, it was really late at night anyway. But I did, I took a little hike in that area to that direction, but I couldn't see anything else.

So there was nothing exchanged on that. It was just a . . . I think we both startled each other. And that's what happened.

David: How human-like would the face appear for a regular person? Would it look like a regular person from Earth with blue skin? Or was there something different about the face?

Emery: Yeah, the face was fuller and more oval, like a bubble.

David: Okay.

Emery: Like if you have a bubble and you just barely . . . If you get one of those plastic balls and you go like this [squeeze the ball with open hands].

But it had features. It had holes in its sides [of the head], not ear lobes but holes. And it was aware, more than 100% aware, and very agile.

David: Were the eyes larger than a regular human on Earth?

Emery: Yes, absolutely.

David: Like how much?

Emery: By at least three times.

David: Wow!

Emery: Yes, it was more eye . . . Like the eye and the top of the cranium, it was larger.

David: But you said the eyes were blue.

Emery: Blue. Blue eyes.

David: So it didn't have the black like you see with a Grey?

Emery: No. When I say blue, you didn't have white. It was blue eyes. I didn't see any pupils. But it could have been it's protective layers. They have these lenses, a lot of the extraterrestrials, they wear over their eyes.

David: It was a solid-color blue?

Emery: Yes.

David: Really?

Emery: Yes.

David: And did it have a nose, or just . . .

Emery: Yes, it had a nose – very small.

David: Very small. And a small mouth?

Emery: Very small mouth. Yeah.

David: Okay.

Emery: And it was very, like, cartoonical. Like, “No way!” It was very comical in a way.

David: And how old were you at the time?

Emery: I was probably . . . ah, '98, I was 28.

David: All right. Well, let's go back to the first one, because this could be very relevant as we get into your military history.

Emery: Sure.

David: What happened in the first event? Let's go through that step by step.

Emery: Okay. I had other multiple events after that, but I didn't understand what it was. I would always do a lot of sleepwalking when I was younger. And I was always outside in a hypnagogic state, but I was

very aware, because I would always come back and mom and dad would see my feet were dirty every morning . . .

David: Right.

Emery: . . . and I'd have no idea . . . Many times they caught me just heading out or heading in.

David: Right.

Emery: And I never injured myself or anything like that.

On this particular evening, and it was not very late, I just was told to go outside telepathically.

David: How old were you?

Emery: I was in second grade, so it was probably around '79.

David: Okay. So you got the impulse to go outside.

Emery: Yeah . . .

David: But this had been happening to you before then?

Emery: No, this was the first.

David: Oh, this was the first time.

Emery: This was the first time that anything like that happened.

David: Okay.

Emery: And then after that, it started happening all the time, I mean just going out, but not knowing why "I'm out here," and seeing lights and stuff.

And so I said, "Okay." So I went outside in the driveway. We had a lake, and I went up to the dock, and I just looked up, and there was this beautiful blue craft. And it was just silent.



And I was just so amazed that it was silent and this craft was there, and I'm smiling, you know, and I was like even singing. I was like, trying like, . . . I don't know. I was like, "Woo-oo!" I started whistling or something. It was very odd.

David: What did the craft look like? What was the shape?

Emery: It was blue, and it was disk-shaped.

David: What kind of blue?

Emery: Blue-white, like white. Not dark, not dark blue.

David: Okay.

Emery: This was more like a whitish, bright . . . , but you could see detail, but you couldn't see edges. Does that make sense?

David: Uh-huh.

Emery: You could see outlines of this, you know, classic shape. And it was telepathically saying that “We're here,” and “We exist,” and, you know, “We're going to be back for you.”

David: Wow!

Emery: And I remember very . . . like it was yesterday. And it always stuck in my head.

David: So . . .

Emery: It happened very shortly . . . I think it . . . The whole event lasted, maybe, a minute and a half, two minutes.

David: Hm.

Emery: It's long. For that to happen today, it would not, because we would shoot you down in two seconds.

David: Right.

Emery: But back then, I think, it was a little bit different. I think they had a little bit more opportunity to make these types of meetings with, you know, not only me, but many other people.

David: Right.

Emery: And to allow them to give us hope and to strive for that later on in life.

So then I just became a really firm believer and all that stuff. And I really wouldn't talk about it that much. Neither would my family.

David: Do you think that either your father or your grandfather might have been involved in black ops [covert operations]?

Emery: Yes, my grandfather was in the Army.

David: Really?

Emery: Yeah. And my father flew in the Navy planes looking for the submarines coming in to the Bahamas and off the coast of Florida. So he was a spotter for that.

David: Really?

Emery: And he did some other things, but I don't think they were intelligence related.

David: You were on some kind of extraterrestrial-contact program it sounds like, and you're describing multiple events . . .

Emery: I don't know.

David: . . . of leaving your house at night . . .

Emery: Oh, yes

David: . . . and going outside. Do you feel like there are gaps in your memory from those events, or . . .

Emery: No, no.

David: . . . what do you think is happening when you go out there?

Emery: No, I remember a lot. When I was younger, I had this gift – I call it a gift. I can control my dreams. I know when I'm dreaming.

David: Hm.

Emery: And it just recently came back to me, just recently, within the past couple months, where I can do it again.

I just lost it after I went into the military. I couldn't do it anymore – when I went into the military.

And I started the military early, age thirteen with . . .

David: THIRTEEN?

Emery: . . . with the auxiliary of the Air Force, Civil Air Patrol, my dad introduced me to. And they were giving pilots licenses to kids for free if you qualified and wanted to be part of this thing.

David: Wow!

Emery: And it's for people also before they go into the military so you get extra rank before you go in – kind of like ROTC, . . .

David: Right.

Emery: . . . which I did that too.

David: Right.

Emery: So you get all these perks. Yes, I got my pilot's license at a really early age.

David: Okay.

Emery: I took many tests that . . . I just know one thing: I took a lot more tests than everyone else did going into the military. And they were not your normal ASVAB test.

David: Okay. Give me an example of something unusual as a test.

Emery: Well, you know, an ASVAB test is based off of . . . “What are you good at? Are you a good mechanic? Let's see if he can figure out this sprocket or this chain.”

David: Right.

Emery: “Or maybe he's good at writing. Does he know a verb, adjective or linguistics.”

David: And that might lead to your MOS – Military Operations Specialty. [Military Occupational Specialty]

Emery: And that's how they lead you out to your MOS.

But with my stuff, it had to do with geometric shapes.

David: Really?

Emery: Yeah, and like mandalas and like . . . “Out of these six, which one do you like?”

Like, “What do you mean, which one do I like?”

So to me, it wasn't a test. But it WAS a test for something! Because obviously, there's some sort of subliminal message in there – maybe some sort of encoding that I don't know about that I have or my lineage has.

David: These could be logos of certain ET groups that they might have been aware had already contacted you.

Emery: Right. Exactly.

David: Right.

Emery: So that's how I got pulled out of the Air Force part after I did my four and a half years and then still continued with the contract work.

David: Had you already done four and a half years in the Air Force before?

Emery: I did four and a half, and then two years of reserve, and then two years of inactive – so a total of four . . . eight and a half.

David: And it's after the four and a half years that you got the salmon filets and that whole thing started?

Emery: No, the first time I got the salmon filet was August 8th of 1991.

David: Wow! You're having these tests. Now, did these tests start all the way back when you were 13?

Emery: Yeah. They started in the auxiliary part. And then . . .

David: So one of them was geometric shapes. Could you give me another example of something that was bizarre as a test that you got?

Emery: There was a lot of high-end physics and magnetic questions, which I didn't understand at that point, but I scored high on it. But I'm really not . . . that's not my thing.

But, you know . . . so I had these amazing job opportunities when I went in the military. But I just wanted to be an F15 Eagle pilot, because I just wanted to fly. You know, Top Gun all the way.

But the Army offered me a huge scholarship that I could not refuse to fly Apache helicopters.

David: Wow!

Emery: But all flight-related, you see, going towards, probably, being an astronaut, or NASA, or other space-related stuff.

David: Hm.

Emery: Most pilots, or most astronauts, as you know, which it's now changed because they need scientific technicians . . .

David: Right.

Emery: . . . for specialty. And that's how I became like a payload specialist.

So getting back to why I was just so adamant that I was going to be a pilot, being just a kid, you know – a 16-year-old when I signed up, by the way – making these decisions.

And they said, “Well, you can also do this medical stuff.”

And I was like . . . And I loved going to the doctor and seeing all the stuff. I liked watching them cut out my ingrown toenails, . . .

David: Ha, ha.

Emery: . . . so they don't hurt so much playing soccer.

David: Right.

Emery: So, it amazed me . . . They're always like, “Sit down. Son, you don't want to look at this. We've got a lot of blood.”

And I'm like, “No, no, I want to see this.”

David: Ha, ha.

Emery: They're injecting me and like, "This kid is frickin' weird."

David: Ha, ha, ha.

Emery: And all these surgeons, too, and these doctors, when I was really young, end up becoming my friends. And I end up becoming their teachers, because I got CME accredited [Continuing Medical Education] to teach them on platelet plasma and stem cells. It was really a funny circle.

David: What is CME accredited?

Emery: Physicians and nurses and all medical people, in order to keep your license, you have to go to symposiums and get updated on new educational properties. So, you know, Continuing Medical Education units.

David: Oh, Continuing . . . Okay.

So let's get back to when you are first brought to Sandia. And I think that's something . . . You've told me before about the process of how you got to the room.

Let's start with how . . . how you get brought in. Like, what was the first thing that you saw that would be a lot different than a typical military experience?

Emery: Well, being in the operating room and working emergency-type situations, and, you know, already knowing pretty much everything about the human body in the accelerated program I was in assisting surgeons.

David: Uh-huh.

Emery: I knew that when I walked into this place, that they had spent a lot of money on these . . . everything, even the doors, the security systems.

These amazing security guards, the demeanor of the scientists and physicians that were there, the technicians and everyone, it was VERY serious. It was very, very organized. And it was very clean. And it took . . . You get debriefed first. You know, they take you . . . It's a huge background check, but I'm already on active duty. So I was perfect for them.

David: Yeah.

Emery: Young. You know, “If he messes up, who cares! You can just get rid of him. He died in a helicopter crash,” you know, whatever.

David: Right.

Emery: So, perfect subject, but super high IQ, very perfect – already has medical training. “Let's just see what he can do.”

So they brought me in this room first – and this was before I actually went to do my first case – and they just laid it all out.

David: Laid what out?

Emery: Laid these contracts out. I mean, just . . . It was so thick.

David: Like you were expected to read all that as you sit there? That doesn't make sense.

Emery: Well, of course, I didn't read it. I was 19 years old!

David: Ha, ha, ha.

Emery: I saw the page, and I was like, “Yeah!” I already signed up. I was already stupid enough to sign up to get into the military, so I was like, “Fine.”

And it's like, you know, . . . which I love, by the way, you know, the military. And they saved my life as much as, you know, made me the man who I am today. So I'm like a huge supporter of the military – still am to this day, which with other projects and things. So I didn't mean to make it sound like I'm not.

I was really thankful for that.

David: Well, we're very thankful for the Alliance . . .

Emery: Yeah!

David: . . . and the fact that they're turning the tables for us here.

Emery: I know!

David: It's amazing!

Emery: It is. All the white hats coming out. It's just a blessing.

David: And we need people like you to be brave enough to speak to the truth and say what they experienced.

Emery: Well, I'm hoping once . . . because I know a lot of these people. I'm hoping once they see me come forward that I really believe there's going to be a lot more come forward like within a year.

David: It's going to get easier too, . . .

Emery: Yeah.

David: . . . because the Cabal is being greatly defeated right now. And you have had a lot of briefings about that as well, which we can get into in later episodes.

Emery: Right. Sure.

David: So you get all these documents.

Emery: So I signed “the book”, and they make it very officious, all these people, you know, the cool lab coats, and other security people, but not in their normal black ops. They're in like clean suits, like really cool, white, tactical stuff.

David: Hm. Like jumpsuit kind of things?

Emery: Yeah, like a flight suit – white, but with a lot of cool straps and not normal guns. I don't think they can use guns down there because of the pressurized systems, is what I was told.

David: Oh.

Emery: And I was always told never to bring MY weapon into the facility.

David: Right.

Emery: You use a locker room at the top. You basically change into scrubs, then go down and change into your suit. So it's like two change-out stations.

David: Wow!

Emery: And you wear a band, which was the coolest thing ever. And this band felt like silicon. I later found out it was graphene, and it glowed.

And that recorded everywhere I went on the facility.

David: Ah!

Emery: And they take it from you. And it also activated later on.

They had iPads back then that make these iPads look like a . . . I mean, thin as . . . You know the X-ray film, how flimsy that is?

David: Yeah, yeah.

Emery: You know, or the films from the . . . we used to use on the projectors?

David: Yeah, yeah.

Emery: Okay. Imagine that being an iPad, and flimsy, and being completely lit up, and accessing the entire main database of whatever section you were working in, and locating your supervisor if you needed to on . . . Everyone kind of knew where everybody was. [There was] nowhere to hide or sneak anything out.

Anyway, you had this cool iPad that was always with you, and you used it for data entry for all the stuff you do because everything's documented.

David: If it's so flopsy, how would you be able to type on it?

Emery: Oh, that's easy. Everything was with your finger, and they had a stylus. And the stylus looked like a thermometer.

David: Hm.

Emery: And it had a very grippy texture to it. And you could hold it, this flimsy . . . It's not THAT flimsy. It's a little bit stronger than that. But it's like that kind of material. It's like a special polycarbonate that, I think, was infused, of course, with probably graphene or some other . . . or, you

know, something photovoltaic, obviously, to do all this stuff.

And anyway, it would always be down on something. It's not a text paper. This is something where it is always on your counter, you're using your little thing, your finger, or whatever, and it also interlocks into other . . . Every room has like a hub, like you plug your iPhone into?

Well, this thing, when you lay it down on a table, the whole table now knows this.

David: Oh, wow! That's cool!

Emery: So it's just like this Bluetooth-type energy.

David: And it's full color?

Emery: Yes. Oh, brilliant full color. Three-dimensional objects. You can . . .

David: Oh, holographic too.

Emery: Holographic too.

David: Really?

Emery: Yes, especially when you put it on the tables, the tables become like the actual 3D part of whatever you're presenting.

David: Wow!

Emery: So, if I did get a body, and that's already been 3D scanned, the body, that can be projected above the table. And then you can move it with your hands.

David: Oh, wow!

Emery: And you can say, "Hey, so I don't know what this is here in the body. We want just this. So cause the least amount of damage to get just this organ or this little BB out."

So it was a very . . . and that just TURNED ME ON, because I was a techie, and I was young, and I didn't want to ever mess up. And I just wanted to keep going.

David: And at the time, right, the time window you're describing, all we had was like these desktop tower computers that were ridiculous.

Emery: My goodness, we had those big bulky . . .

David: Ha, ha.

Emery: I don't even know if Apple even came out, . . . even had their comeback yet.

David: Right.

Emery: They just were. So the wrist band, the little iPad floppy thing, was a very important thing that's always kind of with you. And . . .

David: Could you roll it up and keep it in your pocket, or how would you carry the little floppy iPad?

Emery: Well, you don't have anything on you ever but this band and this piece of paper.

David: Oh!

Emery: You don't have any . . . You . . . I can't have a watch, can't have a piece of jewelry in this facility. Everything has been stripped from you when you do your two change-outs.

David: **Corey**, on this show, has talked about a smart-glass pad. And it sounds a lot like what you're describing. What was it called? Did they ever have a name for it?

Emery: It was always just called "the folder".

David: The folder.

Emery: Yeah, the folder. There was no fancy-like Star Trek name or anything.

David: Right. Well, a lot of times it seems like to, as they call it, "reduce psychological impact" . . .

Emery: Yes.

David: . . . they try to give you these conventional things.

Emery: Ah! That makes sense.

David: Yeah. Right. So it's just a folder.

Emery: Yeah. “Don't forget your folder and your band.” “Okay.”

David: Ha, ha. Did the band do anything else besides just glow? You said it glowed, or . . .

Emery: Yeah, every now and then, it would glow. I think it was just because someone was accessing your whereabouts, especially when there's breaches.

David: Oh!

Emery: There was a couple of breaches when I was there of things escaping. And there's also a scientist technician like me that did try to take some stuff out of the facility.

David: Hm.

Emery: And when that thing glows a different color – there's like different colors for different things . . . And, you know, just do not move and don't go anywhere until whatever is . . . the emergency is going on. Like in hospitals, we have Code Reds and Code Blues, and all this stuff. It's similar to that, that not . . . You know what to do or not to do.

David: What were some of the colors you can remember and what they meant on the band?

Emery: Red means you better not move.

David: Just don't even move at all.

Emery: Yeah. Blue is “everything's fine”. There was one yellow, which means “breach”. Contamination breach.

David: Oh!

Emery: Yeah. Not just . . . No, not like someone stole something. Someone, somehow, had a hole in their suit or . . . because you have to understand these things have viruses. They have bacteria that we don't even know. It can kill you.

David: Right.

Emery: It could mutate. The last thing you want is that out. So they have these artificial intelligence systems in place, and these super-high scrubbers, and like the most amazing disinfecting-type of air handlers you would not even believe.

David: Hm.

Emery: And even walking through some of these things, when you have your change out, didn't hurt or anything, but it was just a precautionary thing.

But they have these vents in the systems that pick up on all particles, parts per million, and it could tell if like one small cold virus bacteria got into a vent, and goes and hits this thing. It's like everything gets shut down immediately.

David: And that's yellow, on the band?

Emery: That's yellow. Yeah. So you never want to see yellow.

David: Do you think that the band could tase you or kill you if you didn't move when it was red?

Emery: I had never felt threatened by that band at all.

David: Okay. Describe to me what a breach means. What did somebody do?

Emery: Well, one time, and this is just from . . . now, I can only say second hand.

I will always tell you if it was me talking first hand or second hand. Second hand means these alarms went off. Of course, we were later debriefed that someone tried to take something out. That's all.

So I don't know WHAT it is. I really was not allowed to ask what it is.

David: Ah.

Emery: But that's what happened to ease everybody's calmness, you know, so everyone can start focusing again better. It's nerve-wracking if you hear ANY alarm there.

David: So you never found out what any of these breaches really were. They just give you a very vague . . .

Emery: One breach I did because my really close friend's husband was one of the security guys.

David: Oh!

Emery: So they did have . . . made an awesome hybrid bear-type osseo-integrated being.

David: I don't know really what that means. Could you be more specific? A bear-type . . .

Emery: They made a hybrid animal . . .

David: Okay.

Emery: . . . of some sort that resembled a giant grizzly bear.

David: Okay, but it was human-like?

Emery: But it had metal . . . yeah. But it had like metal talons made of some amazing . . . you know, it was osseo-integrated into his bone structure.

David: Wow!

Emery: That means the titanium and tissue were together, or whatever metal. I don't know what the metal was. I'm . . . hypothetically just hypothesizing.

David: Okay.

Emery: All I know is once it got out, they had a special truck to get this thing. I mean, it got to the surface.

David: Wow!

Emery: It's going across the desert.

David: Really?

Emery: Yeah. Very fast. So they had to blow this thing up. And it was so indestructible that they only injured it, and then was able to put it into this special truck.

And the truck steel was eight inches thick – the cargo container.

David: Good lord.

Emery: And the marks in it were four inches deep . . .

David: Wow!

Emery: . . . from that thing trying to whatever. It was probably trying to get . . . after they knocked it out or whatever.

So he was there on that. And he saw the marks in the truck as well.

David: Wow! That's crazy.

Emery: And, you know, he would . . . I consider him a very honest person. Plus, it was all over. Everybody knew about it.

David: Wow!

Emery: Everyone knew there was this bad-bad. And that was from a different genealogy department on the base.

David: Well, I hate to leave you on a cliffhanger, but that's all the time we have in this episode. Very interesting story.

We're going to pick up more of this as time goes on.

Emery: Sure.

David: And I want to thank you for watching. I'm [David Wilcock](#) here with our special insider guest, **Emery** Smith. Thank you for watching.

Cosmic Disclosure: Clones and Programmable Life Forms

Season 9, Episode 7

[David Wilcock](#): All right. Welcome back to "[Cosmic Disclosure](#)". I'm your host, **[David Wilcock](#)**, and I'm here with **Emery** Smith.

Emery, welcome back to the show.

Emery Smith: Thanks for having me, Dave. Great to be here.

David: When you first encountered a partial body, by that point, you said you had seen some arms and hands. Had you seen other limbs besides arms or hands?

Emery: No.

Yes, Yes, I saw pieces of like, a face, pieces . . .

David: Oh, really?

Emery: . . . of skin, maybe small fingers. It looked like some sort of appendages, some like, phalanges, maybe toes, feet, parts of, like, legs, very small parts though, cross-section parts, that were cut in a way that you would have to have a very special instrument to, you know, transect these particles of these tissues.

David: Hm.

Emery: The tissue particles I got were always cut in very specific ways. So when we got these tissues, we'd just, you know, of course, start right into, you know, we always had a job what we were going to do with this piece of tissue.

And then later came full bodies and torsos, maybe with or without a head, or a full arm, or other things, even genitalia – all sorts of different things. Yeah.

David: Now, did you have any particularly different surgical equipment? Like did you use a normal scalpel, or was there something unusual about that?

Emery: Yeah, there was normal surgical equipment that we'd normally use, but there was also other devices they had that were more advanced than the stuff that we had at that time.

There were more high-powered lasers and electrocautery devices that we'd normally use in surgery, but on a different level, using different types, I think, of frequencies.

There was one, also, it was like a sonic knife. And later on, that knife did come out to the civilian usage. But I was not familiar with that in modern civilian usage. And when I say “civilian”, also I mean “military” - just normal military hospitals were not using harmonic scalpels at that point.

And my first use of a harmonic scalpel was actually in that program.

David: All right. I want to ask you a question that we might think is dumb, but some people will take very seriously.

Emery: Sure.

David: You're handling exobiology.

Emery: Right.

David: And there's a lot of people out there that think that there are shapeshifting biological beings that can instantly morph from one form to another.

Some people have said that they think the world's elite are shapeshifting Reptilians.

Emery: That's right.

David: Did you encounter any shapeshifting biological matter?

Emery: I think I did. These transdimensional beings, when they get to that level, they are actually a level of consciousness that's beyond . . . like billions of years from now. They get to that light body form, and you can be whatever you want and go to any dimension to help out and do whatever.

But I believe that one of them died here in a 3D shape that . . . how we found him was kind of like a translucent blob, like a jellyfish, but longer. And I think, since it had light with it, I think it might have been one of these very higher-dimensional beings that was, maybe, in the mode of shifting.

Or maybe they had some way of capturing this type of energetic form. Like, you know, somehow encapsulating it, and then bringing it in.

It did give off light, but it didn't give off any type of frequency that we could pick up.

David: So it was approximately like an oval, like a human-type of shape, but just in a very general sense?

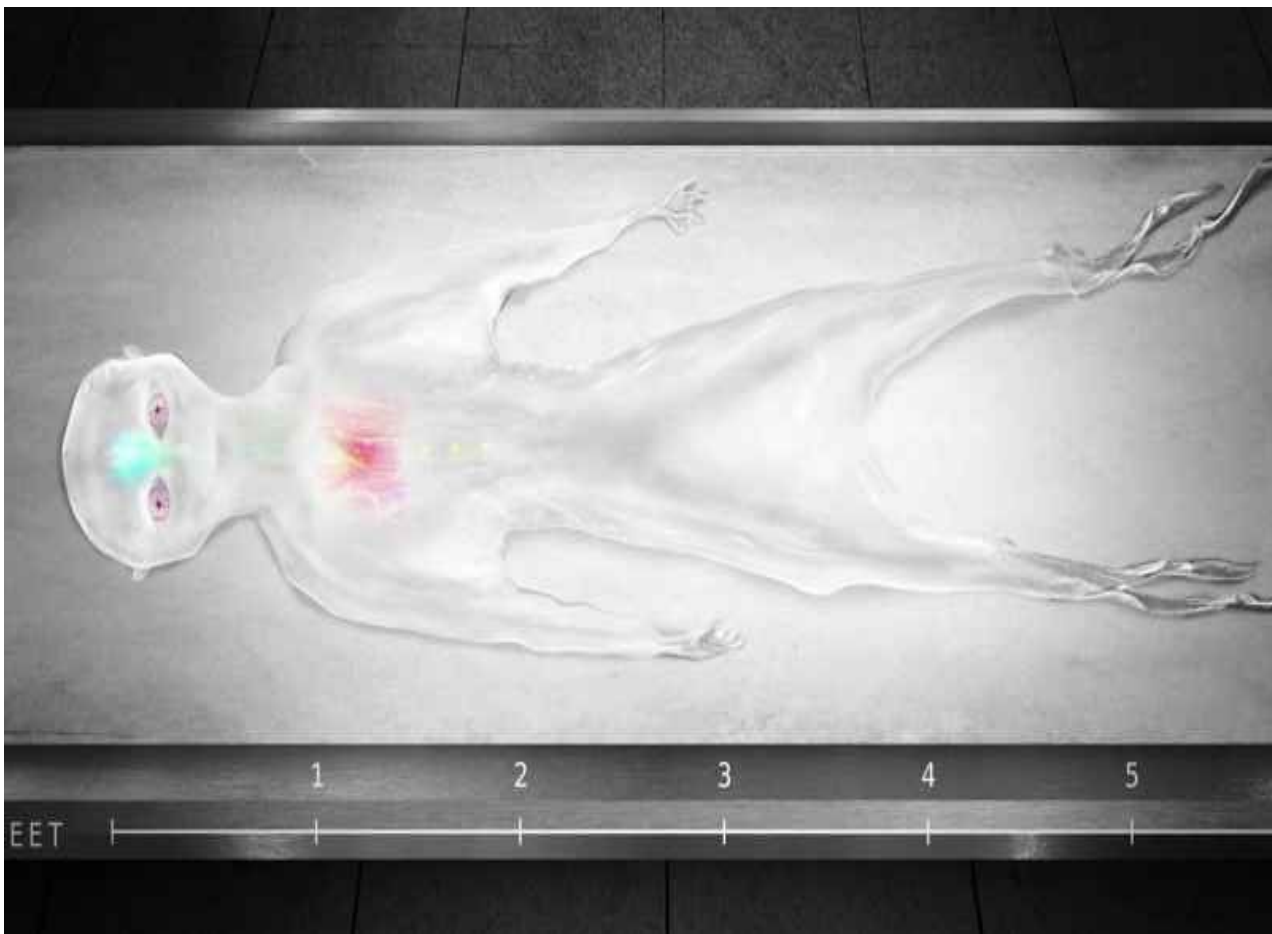

Emery: Yeah, it kind of looked like a cookie cutter – like you make those cookie-cutter doughboys at Christmas – but very bulbous, and round, and very liquidy.

David: How tall was it?

Emery: The one I was on was about 6' tall.

David: Okay.

Emery: Yeah.

David: But did it have any differentiated features that you could identify with the autopsy?

Emery: That was the problem. Those pieces of equipment they gave me to utilize to take the specimens did not work, because the tissue was fluid.

David: Oh.

Emery: So we were just using syringes, basic syringes, and needles, and special suction devices. And we were sucking just very small amounts of different parts of the body.

And I don't know where this being . . . that was my own conclusion, by the way. I don't know where this being came from, or how it even got there.

Later on, I learned more about extraterrestrials, and that's how I put two and two together.

And, of course, you know, transdimensional travel with extraterrestrials, and how they do it, and so forth.

David: So I would assume this had some sort of thicker membrane to hold the fluid in.

Emery: Yeah, it did. I was about a centimeter thick. And it reminded me of a very thick Jell-O. And when you cut it, it had a glow to it – when you cut it.

David: Inside?

Emery: Yeah, kind of like a cyalume light stick glow.

David: Wow!

Emery: Yeah. And then it would just go away. And then that's when they said, “No more cutting. Start using needles and suction,” - very, very sharp suction devices we have that are very, very small, like 30-gauge suction devices, like 30-gauge-needle-type suction devices. And we were taking VERY small amounts of different parts of the body.

David: What would you say the viscosity of the liquid was inside? Was it like water, or was it more like a thick syrup, or . . .

Emery: Yeah, it was like a clear maple syrup.

David: Okay.

Emery: Yes. And there was parts inside that you could see that were giving off light – pink and purple and yellow.

But it looked like they had shapes, because this is a translucent being, but it's like you're looking into a clear Jell-O. So it's distorted – what that was.

But they would not let us take any samples of the colored liquid.

David: Wow!

Emery: Maybe someone else did, because it was so compartmentalized.

A lot of beings . . . A lot of different technicians had different things they did. And I wasn't that advanced at that time. So I did very simple things.

David: I think probably one of the hardest things for people watching this is going to be, “Come on, man!”

Emery: Yeah.

David: “You didn't try to ask anybody a question about what these things are, or where they came from?”

Emery: No, no. I signed a very big briefing document, and I knew what I was kind of getting into. I thought I was going to be actually doing just cadaver work on soldiers, but it wasn't.

When I got in there, it started escalating. And then I knew how serious it was.

And I have also heard of stories, whether they were true or not, of people talking after hours and things. And, you know, they'd go missing really quickly.

David: Wow!

Emery: So it was a very high turnover rate for technicians there, for clinical specialists, that were doing this type of work.

So I was really good at keeping secrets and keeping my mouth shut. And it got me really far. It was frustrating to a point, but I was so intrigued, and it was so, you know . . . I was just so enthralled with it.

I actually kind of got obsessed with going to work and wanting to know more and more and more, because I was coming up with my own conclusions.

And then I just started studying it on my own, which, there was really nothing out there at that time for that kind of extreme . . .

David: Did they monitor your usage of like a library card or Internet or . . .

Emery: Everything that I had was completely under full surveillance, 24/7. That was part of the deal, too.

And anyone that was with me would always be . . . not . . . they wouldn't TELL them, but anyone, my friends or anything. So it was hard to have friends and relationships.

Even up to this day, it's very hard for me to have anyone close to me, because I'm afraid for them to . . . you know, something would happen to them, because I've basically lost everyone so far.

David: That's right. And very soon after you lost all your stuff is when the brakes went out on my car.

Emery: That's right.

David: So.

Emery: I remember that.

David: All right. One of the things that I think we should cover here is the awesome size of the facility that you were working in, because we kind of got into that with the colored lines before.

Emery: Oh, right.

David: But if you personally are saying that you . . . Well, again, tell us how many different unique species did you appear to have seen?

Emery: Well, I'll say "specimens", because I count my specimens as a species. Whether it was a real extraterrestrial, or it was something grown in a lab, or if it was just a disinformation piece of tissue they

would throw out every now and then to technicians, which is very common in case something happens, so you won't be credible.

David: Right.

Emery: And so I would say a little bit over 3,000. And don't forget, you could do up to 10 to 20 examinations in one day if you were just doing very small harvesting biopsies of small tissue, just for DNA alone.

David: Oh, wow.

Emery: And then you might have one that would last you a week of analyzing, and collecting specimens, and giving reports to specific individuals.

And sometimes there would be more than one person that would come in and observe you, and say, "No, do this," or "Do that," instead of using the speaker phone head system for some reason. I don't know.

David: What would be the first thing that you would see when you pick up your folder?

Emery: It basically had basic stuff on it, like time, date, your room, you know, a "Red 12", what they want you to exactly transect: "Just pull out the nerve," "Just pull out the muscle," "Just take this amount of tissue," "Just draw up this amount of cc's of this liquid from this part of the body".

It was very definitive of exactly what you were going to do.

And time was . . . They were really big on time and performance. So you would go in there, and you would not know what your second one would be on that pad. So you wouldn't know until you completed your first one.

David: So you might only have, let's say, 60 minutes to work on one cadaver?

Emery: They don't give you time.

David: Oh.

Emery: You do what you do. But the faster that you do these things, and the more proficient that you are at it, they like you. You know, of course, I'm moving more samples than anyone else.

So . . . And I was used to harvesting human tissue, anyway, with harvest transplants and stuff. So it was very easy for me to fall into this category and do these procedures.

David: Did they tell you what surgical instruments to use? Did they have that much of a protocol, or did you have some freedom?

Emery: Well, I pretty much have access to anything. There was a few times I went on the intercom and said, you know, "Hey, I need this." "I need a number 11 blade," or "I need a rongeur of this size." It depends what it was.

But most everything is in that room that you could get from the wall. And if not, they would put it through, and you would get it, like, immediately, within a couple of minutes.

David: In the late 1990s, this alleged alien autopsy film came out – the Santilli autopsy film. I assume you've seen that.

Emery: I've heard about it. I didn't follow much up on it. I remember at the time, I did review it. Yeah.

David: Now one of the weird things about that film is that the . . . and there's debate to this day, and mythology, as to whether it's real or whether it was a very skillful fraud, but one of the weird things is that they peel this black thing off the eye, . . .

Emery: Oh, yeah, I saw that.

David: . . . and then the eyes are like looking up into the head underneath.

Emery: Absolutely. Yeah. A lot of the extraterrestrials that I've actually seen, their skulls and heads and stuff always had film over them, unless it was already taken off by somebody else.

David: Really?

Emery: And it wasn't always black and green like you hear in the stories. It could be many different colors. I've seen violet. I've seen pink. I've seen . . . but that film is always there.

David: Really!



Emery: There's always some sort of film or cap over the eye. And it kind of like conforms to the exact . . . whatever eye shape it is, whether you have a diamond eye, or a trapezoidal eye, or a hexagon eye, or a round eye. They're not always round, by the way.

David: Hm.

Emery: And it's just right over there. And I'm not sure. I always thought that's how we back-reverse-engineered night vision and infrared, is through the reverse-engineering of these ETs that they found, way back when, in the Navy.

And I remember hearing some generals talk about how they took these films off, and those were light-gathering and also light-suppressing films that were not biological, by the way.

David: Was there like a “Google Glass” component to it, like a heads-up display with information that you see?

Emery: No. I'm sure that most of these beings, if they were here, they have already telepathic . . . everything is projected into their consciousness and brain.

David: Hm.

Emery: So I'm pretty certain they wouldn't have any cool helmets, or chairs, or anything like that they sit down in. It doesn't exist.

When I see these craft people show on TV, on a couple of shows I saw, they're like showing these cockpits, and all these buttons.

David: Right.

Emery: And I'm like, wow, they have no idea.

David: Did you find evidence of beings with hardware, like technology hardware in their bodies?

Emery: Yeah, yeah.

David: And what types of hardware?

Emery: Yeah, not just even hardware, but also on the outside of the bodies, which is really neat, such as things that come out of their head to their mouth and nose, from the back of the head.

I found many types of – which would show up on X-ray – cylinders inside the body. But I was never allowed to take one out or to touch it. I don't know what it was used for, but they were always cylindrical, like capsules, like that you take with vitamins.

David: Like that size.

Emery: Like that kind of size. And they could be . . . I mean, no, that shape, . . .

David: Oh.

Emery: . . . but many different sizes.

David: Hm.

Emery: And sometimes in many different places of the body.

And I don't know if that was put in there by us, or that's just something that they use for their . . . to help communicate with us or something.

I had a feeling that it was more of an adapting process for the body to maybe survive in this atmosphere. And it could have been a field, too, to protect the body.

There's many extraterrestrials that have fields around the body. You can't . . . It's very thin, and it's very small. You can't see it, but it's so thin. It's microscopic. But it's there, and it protects the whole body from this atmosphere.

David: Hm.

Emery: And I think these other devices that we see coming out of the ears or the head, that come around over the mouth and nose, probably has to do with atmospheric breathing and communication.

David: Hm.

Emery: My belief, anyway.

David: The reason why I ask that is that you described them seeming to be downloaded with information. You said that they wouldn't need a heads-up display on these little things that cover their eyes.

So is that some sort of wet-wired technological interface with their consciousness?

Emery: Yeah, I think a lot of them have advanced to this consciousness-assisted technology that they either implanted into themselves, or, just because of them growing over millions of years and forming into these amazing beings, have developed ways and sciences that we cannot even understand or comprehend, because we wouldn't understand the science, because the science doesn't exist yet.

It would all be there already inside the being.

We're talking about beings that have obviously traveled billions of light years, or thousands of light

years, to get here. So they have mastered this travel across the universe, and maybe even transdimensionally.

So it would only be well-suited to believe or think that – and that's just my hypothesis, by the way – that they would have this technology already ensued in them.

David: If we have this wet-wire interface, could there be, in certain cases, a sort of booby-trap effect where that would self-destruct the body so that it couldn't be identified? Do you think that was ever happening?

Emery: What I do believe in, what I have heard second-hand from being in the projects, is: a lot of these beings that came to the planet were actually clones of their own – the 3D ones that were actually maybe captured – were actually clones of their own. They were like programmed life form beings.

So they clone them, they program them . . .

David: They clone themselves, like their own body?

Emery: Right. They clone themselves, or they'll clone a similar being from them. And they'll . . . Programmed Life Form. We call them PLFs.

And these PLFs are . . . They're half cybernetic and they're half organic. And so they can move very fluid, like a person. You would not even know.

And when they crash or whatever, sometimes ETs actually want to crash their vehicles here to help upgrade us so they [humans] can reverse-engineer the stuff. And the bodies they find are actually just these PLFs that maybe last a week or up to a year with no sustenance.

But they found that out the hard way. When they were capturing these – and most of them were dead when they crashed – and they were putting them in alcohol or formaldehyde, and the body would instantly just dissolve.

Because it's not like something we would catch here and put in our lab, an animal, or a human hand, or a brain, or something that has a very strong tissue, collagen structure. It was made up of a synthetic

structure.

So they started using saline and special types of water and plasmas.

David: On the 50-year anniversary of the Roswell crash in 1997, Colonel Philip Corso came out with the book, “The Day After Roswell”.

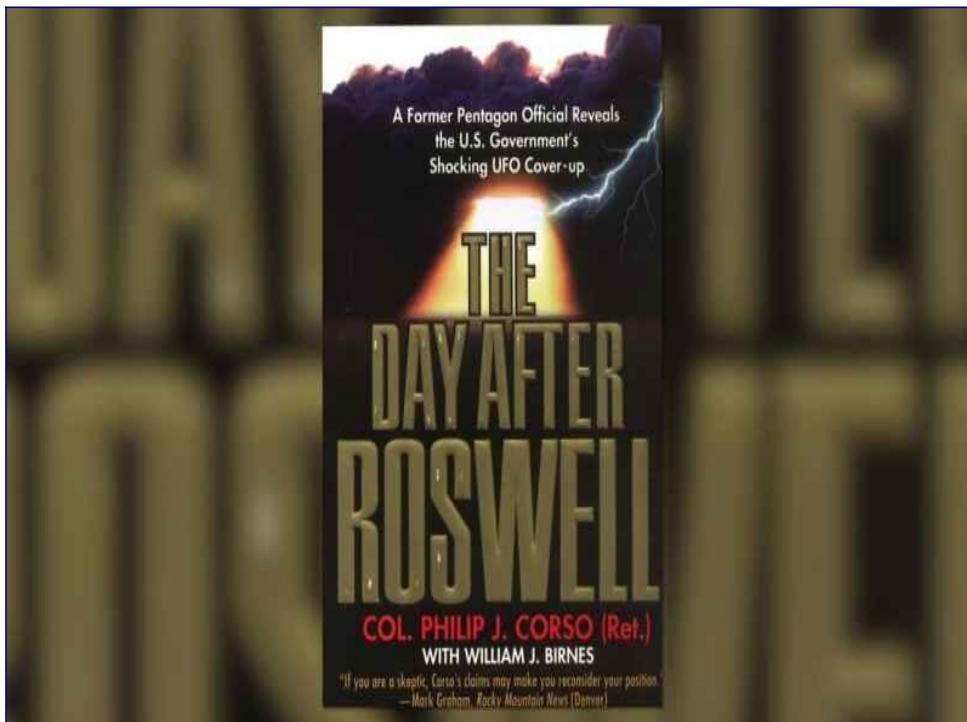

And one of the testimonies that he had in that book was that the original Roswell beings . . . our government was very confused, because they basically had, like, a tube that went from the esophagus to the anus. And there was really no . . .

Emery: Exactly.

David: . . . digestive system.

Emery: Right.

David: So how does that relate to this PLF thing?

Emery: That's exactly what a PLF would look like. The design of that – and I have worked on clones and PLFs before . . . There is no digestive tract or anything, but they're somehow able to have an electrical charge in them that is sustained for a while, that helps the muscles, and their bodies, and also

transmit data to whoever sent them.

And they don't need . . . I mean, I don't know what that tube is for, but I know exactly what he was talking about, because we've seen these tubes.

And maybe they have something that they have to take, because we've seen multiple tubes that go off of this tube – like a tree -

David: Oh! Really?

Emery: . . . a branch. Yeah. But it doesn't go anywhere. It just goes into this spongy tissue, which is made up of muscle, and just tendons and stuff.

And also incorporated with that is a type of metal, and other info-, exo-, not an exoskeleton, but an inner skeleton that keeps these beings, I guess, alive for the mission.

And I think each one of those are made for every different mission they have, whether it's crashing into the ocean and giving us some stuff, or carrying out . . . collecting lavender in a field or something.

David: The material, genetically, that makes a PLF, is that grown, or does it have to be actually taken from another being? How do you get the material, the biological material?

Emery: Unlike here, where we grow stuff on Earth, like beings and clones and hybrids, extraterrestrials actually formed this through harmonics and frequency and sound.

So they can make anything, cells, or synthetic cells, which I'm pretty certain they're synthetic, through some of the stuff that I've collected.

And, by the way, I've never got to see an actual synthetic cell under a microscope, or an electron microscope. but just from debriefings I have been on and things that I've seen with my physical eyes, I can tell the tissue was not real tissue, but it was operational tissue.

Just like today, they have pieces of synthetic things they can put in your body to replace a tendon or help strengthen a vessel. You know, we put vessels in all the time.

David: Just to be clear, though, if you're saying it's a synthetic cell, it would still have amino acids and proteins . . .

Emery: Right.

David: . . . consistent with life.

Emery: Right.

David: It's not like it's made out of plastic.

Emery: Yeah, that's what I'm saying. It's more of a hybrid of synthetic and real organisms, but it's not one or the other. Because from what – this is second-hand – what I heard, they didn't have mitochondria in them, and they didn't have DNA, but the cell did operate the way it was supposed to operate.

David: Weird.

Emery: Yes, very weird.

David: If there's no mitochondria, how does it have energy?

Emery: Yeah, good question. That's science that I wouldn't even know about yet.

David: Right.

Emery: But that is something that's asked.

David: Can they culture, like, a small sample of tissue, and then make a lot more, and then use that to grow one of these . . .

Emery: I believe, personally, that's what they're trying to do with all these samples. I wasn't in on that.

David: Oh.

Emery: I do not know. I've heard that . . . Of course, most of the samples are not just tested. They are trying to learn how to hybridize these cells with human cells, and trying to grow things in the lab by mixing these cells together, is what they're trying to do.

And I didn't find that out 'til way later down the road, by the way. So THAT I do know.

David: If there are synthetic aspects to the cell, what would be something that we might identify? Would we find molecules? Would we find alloys? Is there metals in the cell?

What kind of things might be unusual?

Emery: Well, the unusual things that I've heard after this . . . and this is not me seeing the cell.

David: Okay.

Emery: Just so you know, I've seen briefings on my folder. I went through many things where they had pictures of these cells, but I did not see this. I did not personally see the cell.

David: Okay.

Emery: They had many different shapes. And they had . . . A lot of them were geometric, which is weird, because . . .

David: Wow!

Emery: . . . that means it's a lattice. It's not . . . Like, cells are spheres, most of them.

David: Right.

Emery: Or maybe they're a concave disk, like a red blood cell, which is a very unique design. But these cells were more of a lattice. So they formed shapes, and they formed honeycombs and different things, and they definitely had an electrical output to them. And where that came from, I don't know.

So they kind of ran off, I think, their own field of the energy of the Earth for a certain amount of time.

And maybe that tube was used to put certain elements in to help with the electrical part of the body, because those were all temporary – the ones that were found here.

But I'm sure they have ones that last a lifetime.

David: I'm trying to help the skeptics along here, just in terms of . . . You know, a healthy skeptic, I think, would ask healthy skeptical questions.

Emery: Right.

David: We seem to view biological material, clone material, as being rare, valuable, hard to make. And you're talking about beings that are like plastic bags.

Emery: Right.

David: Like one week and they're done.

Emery: Oh, no. Yeah. Yes.

David: So how could these genetic materials be so abundant that they would be that disposable?

I guess I'm having a hard time understanding.

Emery: Oh, that's easy. I mean, number one, these beings, I'm telling you, they can make anything they want. They don't need our gold. They don't need our sperm or our eggs.

David: Right.

Emery: I mean, that's something they could do on their own.

David: Right.

Emery: They don't need to come here. If anything, they're trying to preserve us. But they don't need . . . They're trying to preserve this DNA at THIS time, maybe.

But getting back to your question, is that right now, even in OUR projects, right now we have the ability to 3D print any organ in your body that you need. A lung? No problem. A heart? No problem – with your DNA, using your cells from the tissue from the broken or dead organ, or from another part of the body.

David: Wow!

Emery: Because enfolded in the DNA is actually every part of your body.

David: Right, of course.

Emery: And that's what's so cool. And when you open the DNA up, I can say, "Oh, here's Dave's heart", put it in the computer, and now the printer will print your heart. And now we can do a heart transplant with your own heart, but we'll give you one a little bit younger and stronger. And we'll juice it up.

David: I want to toss in something that my insider, Jacob, said to me once, which was that we are currently believing that neurological tissue cannot be regrown. And, yet, he had reports of people who had been through catastrophic spinal cord injuries, and that even if the nerve fibers had completely gone dead, and rotted, and been reabsorbed by the body, that they could put this thing at the base of the spinal cord in the neck, and that the nerves would just grow back into the body, and the person would get all their function back.

Emery: Absolutely true. And even on a medieval way, like with a system they created with stem cells, harvesting them from fat and bone marrow and blood, we have had amazing experiences with quadriplegics and people who have had really bad spinal cord injuries come back.

And so with the neural stuff, we CAN grow any cell. There is not a cell we can't grow. That's fake. That's false what they want you to believe. And that's what's the truth.

David: Do you believe, as other types of insiders have said, that there is a negative aspect to our planet at this time that is seeking to reduce population dramatically?

Emery: I do believe that. And you can see it every day. It's not hard.

I hate to call out corporation names, but, you know, and things that are going on everywhere with politics, because I try to stay neutral.

David: Right.

Emery: But yes. I mean, you can just look around and see. It'd be so easy to do. I mean, if there was just no electric [electricity] for a couple of days, and I'm diabetic, and I can't get to a Walgreens for my insulin shot. You know how many people in the world have that.

David: Right.

Emery: So, I mean, these little things that you don't really think about. It would look so harmless that all these people died, but, you know, if it was an intentional way to do it.

David: So what I'm getting at here is, if you're saying that any part of the body could be grown, I assume that would also mean if somebody loses their arm, you could grow another arm for them in a vat or something and attach it, right?

Emery: Oh, it's beyond that. If I have just a few of your DNA that's not completely destroyed – it's not completely dead – we can actually just take that DNA and make your whole body back, because it enfolds within it all the consciousness things that you have endured through this lifetime like a hard drive. And you're still you.

And we can grow that – your whole body.

David: Would there have to be some sort of biologically-based broth, or something, that you have to feed these cells with in order to get them to grow?

Emery: Yeah. It's protein, amino acid based – the very basis of life. All of the things that you hear about is what it's full of. And the computer knows when to add collagen, when to add osteocytes and osteoclasts, and all these different cells in the body to help reform it.

And sometimes there is a glitch in the printer, and some things happen, but it immediately puts the cells in there to fix it, which is amazing.

David: Really?

Emery: Yes. And these are huge vats that, you know, . . . You can basically regrow yourself, if needed.

David: We have just a couple minutes left, but one of the things I wanted to cover is, in previous episodes, you talked about seeing what may have been a 10' tall Reptilian in custody.

Emery: Yes.

David: But then you very – I would almost say flippantly - “Oh, yeah, it could've just been something we grew.” Like it's no big deal.

Emery: It's no big deal. We can grow . . .

David: How did you get to the point of knowing that that could have been done?

Emery: Because that's why I went into the regenerative part and started learning a little bit more about what they were doing with growing cells and growing things.

David: "They" who?

Emery: The labs.

David: Okay.

Emery: We'll call them the labs. And what they were trying to do, like I said, is also make fake extraterrestrials, . . .

David: Right.

Emery: . . . to make . . . just have them in their back pocket just in case, to make them look good, bad, evil, or happy, or healthy, or scary, or good-looking, whatever they wanted to do. And they did. They're very successful with it.

So that's why I said, when I saw this being, this species or whatever, maybe . . . I don't know where that came from. I can't tell you.

I could say that I believe it was real. And it was smelly and breathy. You know, it breathed.

But that's where PLFs come in, too. So programmed life forms are the same thing: are grown species that are programmed to do certain things, certain jobs.

David: Without naming anyone specifically, I have a story about one of our former presidents, and this idea that they can be cloned, and that you might be seeing someone who looks exactly the same, but it could be a totally different biological form than the one that's the real one.

Are you aware of that?

Emery: Yes, I am.

David: Okay. So is there some problem with the clone in terms of, like, if you had a conversation with it, does it have the same memories? Is it aware that it's a clone?

Emery: No.

David: Or does it think it's the same person?

Emery: It's not like I was telling you earlier when we take your DNA and make you. It's . . . We take partial parts of your DNA, make you as a clone without the consciousness part of it. So we . . . It's programmed into you. We program the memories into you.

You might think you had a family, and that you knew that you took this job to look like this president. Up to date, all the way back.

They could even make more clones to be put with you to make you think you have a family, or you would just think. Or maybe they just need you for one job.

David: Wow!

Emery: Yes.

David: Wow! This is really intense.

That's all the time we have in this episode of [Cosmic Disclosure](#). I'm your host, **David Wilcock**, and we are here with **Emery** Smith, exposing the truth about very advanced genetic programs involving extraterrestrial biology.

Thanks for watching.

Cosmic Disclosure: Staged Alien Abductions

Season 9, Episode 8

David Wilcock: All right. Welcome back to "[Cosmic Disclosure](#)". I'm your host, **David Wilcock**. And we are here with **Emery** Smith.

Emery, thanks for being here.

Emery Smith: Oh, thanks for having me again, Dave. Appreciate it.

David: So in our previous episode, we started to talk about these genetic programs that have been done, including this idea of synthetic cells, synthetic biology.

And you mentioned something that I think . . . It seems to come very easily to you, but it was probably difficult for a lot of people to really grasp: this idea that . . . it sounds like, from what you're saying, a very large number of clones could be manufactured by various processes.

What is the fascination with making all these clones? Why are they so involved in manufacturing life forms?

Emery: Well, I think they have their own agenda. And each organization has its own agenda.

I mean, there is, of course, one operating everything, but you have to understand it trickles down to many different types of facilities and agendas and organizations. And, you know, who knows where it goes from there?

But, you know, I can have . . . I believe in my opinion that they're doing this to maybe form a fake . . . or stage a fake invasion maybe, or use these beings as part of . . . to serve in a war of some sort, or to even possibly use for abduction purposes.

David: Abduction is something that began with Betty and Barney Hill in the early 1960s.

Emery: Right.

David: And from that point forward, we have these alleged Greys that are apparently doing this.

Emery: Right.

David: So I'm curious as to: why do you think really there were not reports of Grey abductions before Betty and Barney Hill? And what might that be that we're seeing?



Emery: This is the most controversial question I get all the time, and I have the great answer for it.

And, you know, these people DID get abducted. Okay? It really did happen.

And that's why they can pass a lot of the truth tests. And we're interviewed a lot of these people. And it's real. I mean, they really had this experience in their mind, you know, or physically.

But what I'm getting at is it wasn't real as far as the beings and the stagecraft and the things that were going on, because there's many of these stagecraft and these programs running the entire planet because they all want them to coincide together.

So when we interview an abductee from New Hampshire, they have the same exact story as the abductee from Namibia and the abductee from Japan, because they make them very similar, and then they'll do many different types of episodes of what they want that person to see and remember, and how to make them traumatized.

And they can do that in many ways by, number one, using fake stagecraft, using clone programmed life forms, knocking them out first, and then having them wake up in a room with staged surgeons there prodding and poking at them, using special types of gas.

David: Wait a minute. Are you saying that the UFOs are fake?

Emery: Yes.

David: Okay.

Emery: Well, they're . . . right.

David: But is there a craft? Are you saying that there are craft that can be flown?

Emery: There are craft. Yeah, they're real craft that we reverse engineered.

David: Okay. Right.

Emery: But they are OUR craft. They are not the extraterrestrial craft.

David: It's not just like a hologram? There is a craft.

Emery: Right. They can use holograms too, though . . .

David: Okay.

Emery: . . . that have been used in staged moments, absolutely. And they'll show the hologram, and then maybe let off a gas in the area, and the people maybe crash the car.

The next thing you know, they wake up in some facility, but it's blurry. They're always groggy for some reason. You know, something happens.

Or they'll come to the house and do it. You know, they'll pick a specific person.

David: Before we go any further, I just want to ask you this question, which I do know the answer to, but I want to get you to say it on camera.

Have you been watching "[Cosmic Disclosure](#)"? Are you familiar with all the ins and outs of what **Corey** has said?

Emery: No, I don't watch it. Sorry. Yeah.

David: And the reason for that is what?

Emery: I don't like to be influenced by any type of outside source of any type of outside source of information coming from another person in case one day I might HAVE to come forward.

And it's interesting sometimes when you tell me, "Hey, **Emery**, I actually had an insider that told me almost the exact same thing", because I know I'm not the only one.

David: Right.

Emery: There's hundreds of thousands of **Emerys** out there that are just petrified to come forward.

And I'm hope that this series will bring a lot more people forward to feel a little bit safer.

David: Right.

Emery: Because it does protect you, I can assure you.

David: Why do you think that these abductions are being done? We're kind of going around it, but I don't feel like we've quite hit it.

This is something that would take incredible resources. We're talking about craft. We're talking about beings being cloned. You're saying that it could be in America, Namibia, Japan.

What is the point of all this?

Emery: To install fear in the world. You know, fear needs to be installed to control and order, you know, to have control and order over a civilization.

So what better way to do that: to have these people on TV saying that this happened. And I'm very compassionate about them, because it really did happen, but it didn't happen the way they think.

That's because Hollywood has basically released an evil alien movie every month, and it goes from here to The Philippines in a year. And everyone in the world is now petrified of this giant creature coming at me.

David: Do you remember last night when we were talking to that guy, and you had told him about the little Atacama being? And you remember the first question that he asked us was: “Am I supposed to be afraid?”

Emery: Right.

David: Why do you think that was the very . . . and he kept asking it in different ways.

Emery: Yes.

David: Like: “Am I supposed to be scared about this?”

Emery: Well, “We shot them down. Are they going to come back with their guns and kill us?”

David: Right. Right.

Emery: You know, and it's like they know the risk. You know, the Earth is what I call the Disney World of the universe.

David: Ha, ha.

Emery: And it's a very dynamic, beautiful place. You know, you would laugh. You know, let's go see a bunch of hairless monkeys, right?

But what I'm getting at is it's such a diverse community of so many living biological species that they used to come from all over just to kind of like hang out, look around and not do anything malicious or anything.

And this is in and out of all the other negative stuff that has happened millions of years ago with the different civilizations, by the way. I'm not getting into that.

I'm just saying, in this time of age, really the last 1,000 years, it was a really beautiful place to come and show your kids.

David: Hm.

Emery: And this comes down to now after Roswell and a little bit before that with the Germans when they realized there were these other entities, some formed alliances, some didn't.

And the next thing you know is gas, coal and oil got involved and didn't want any of this type of stuff going on, or the government.

Because if you prove how extraterrestrials get here, they weren't using gas, coal and oil.

But getting back to your question: why did he say this? It's like: "They're going to come back because we just killed his family, or we shot down a craft."

And I was like: "Well, you know, they're a little bit more conscious than we are by a few million years. And they were once us. And they're watching us grow out of this barbaric, medieval way of cutting each other's heads off."

And that's why we haven't been back to the Moon, or, you know, ventured into space with the normal NASA space program, that is.

David: Right.

Emery: And that's . . . You know, this whole stunted thing is: until we learn how to behave with each other and love each other and accept each other and not have this association of, you know, "you're my enemy because you don't believe what I believe in," or "you're a different color of race or gender."

It's ridiculous. It doesn't exist in the higher consciousness of extraterrestrials beyond this universe.

So they're giving us time to behave and time to work it out on our own. And they WANT to see this happen. And they're really interested in that.

So that's kind of what I believe they're there for.

David: I had Whitley Strieber, who is the famous guy who wrote the book "Communion", kind of broke the alien abduction story in a big way in the 1980s . . .

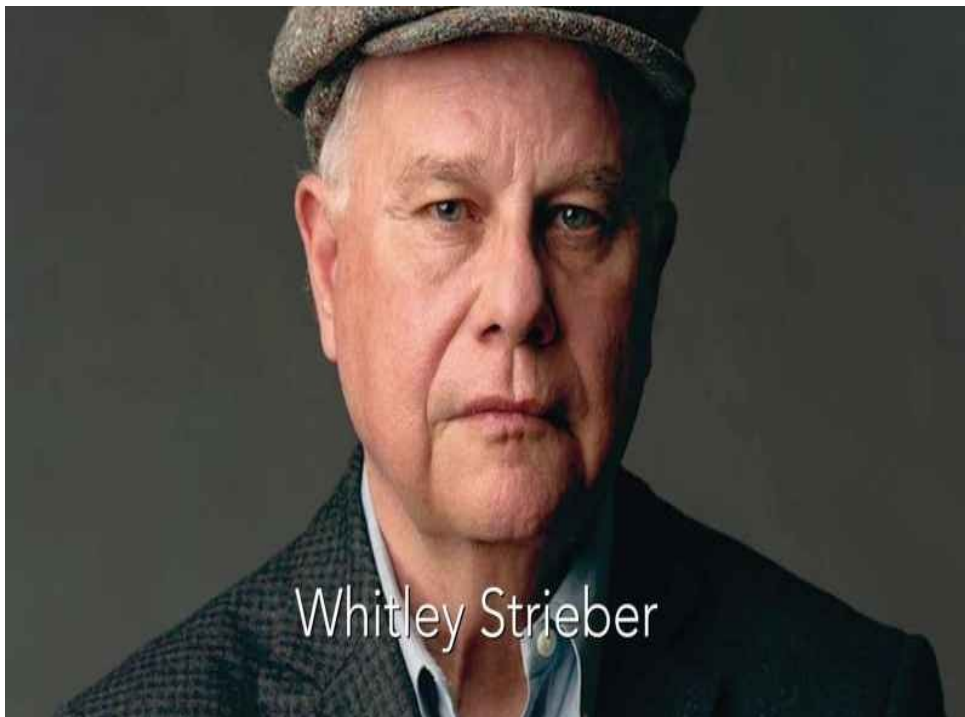
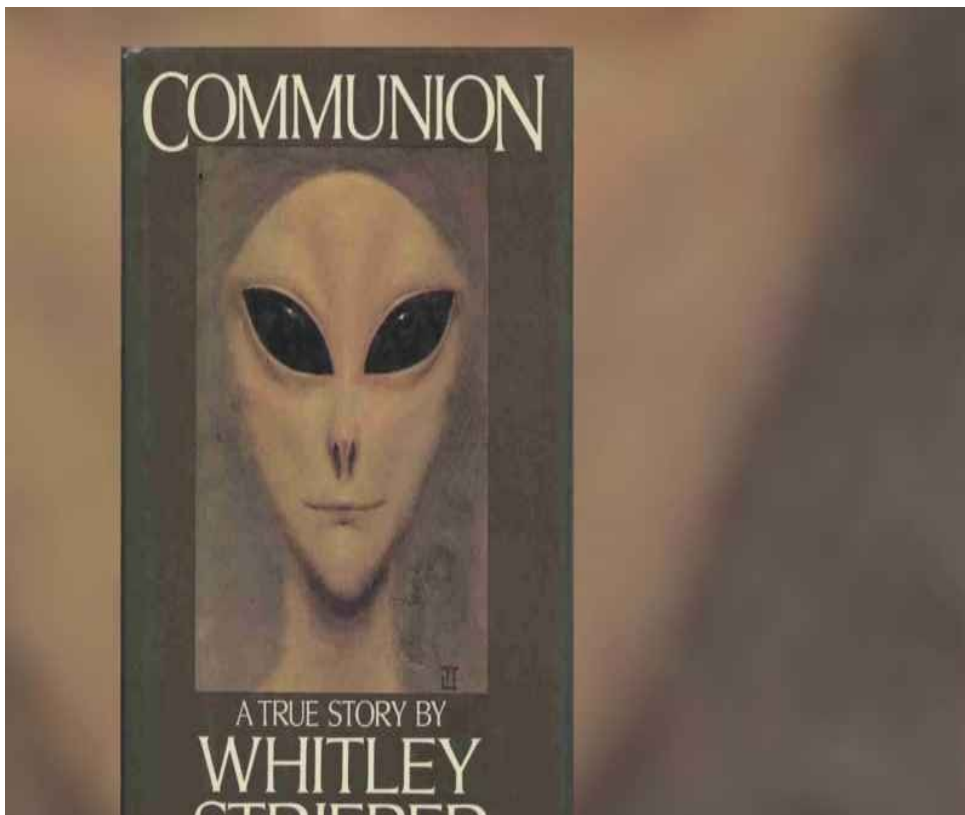

I had Whitley Strieber on my panel at Conscious Life Expo in February 2017.

And one of the things that I thought was fascinating was that he reported having more memories of his

abduction, and that he wasn't just seeing Greys. He was also seeing regular humans in black military uniforms who were there at the same time.

What do you think is going on with that?

Emery: What has happened is, yeah, he was probably moved to an installation or something. Or maybe the black ops team for that division, when he came to a little bit, his memory caught a glimpse of it.

I mean, we give medication every day. Every day, we'll do thousands of millions of surgeries around the world. We always give patients Versant right before they go, so in case we do mess up, or they don't hear us telling jokes while we're operating on their heart, they won't remember it. And it's very successful.

But they do sometimes have a total recall.

David: Ah.

Emery: And that's bad. That has happened . . . You can Google that where people are actually awake during the whole procedure and remember everything.

David: Wow!

Emery: Or they'll hear everything and remember it. And they can't move 'cause the anesthesiologist has paralyzed them.

David: Wow!

Emery: Yeah, very scary situation. So that's what happened. He is getting a little bit of a recall back because the drugs didn't work on him, or the gas.

David: So this abduction program would be to instill fear on a mass scale.

Emery: Correct.

David: So there was a sense when Whitley was saying this that he might have been abducted by the military.

Do you think that there are real Greys doing real abductions that are actual extraterrestrials? Or do you think that this is just a vast weird government program of some kind?

Emery: I believe it's a program. Right.

I believe there have been . . . there may have been, not to my knowledge, there may have been like real abductions a very, very, very long time ago because of certain countries that were making some weird, bad mistakes of exchange of information maybe for DNA.

But it's hard for me to believe that now, after what I've been exposed to, knowing what they CAN do anyway . . . Like I said, they don't need anything. But there's a lot more to that story with other beings and other things.

So I believe it's a complete form of military, or some sort of faction organization that works beyond the military, that's doing this.

David: Now, I remember at least three or four times seeing Dr. Steven Greer speak on stage, and you were standing there on stage in full tactical gear as his security guard.

Emery: Uh-huh.

David: And in some of those talks, he mentioned a UN Secretary General being abducted. And that is the highest level of politics on Earth. So what could be going on? Why would this production go all the way up to the elected heads of state in the highest offices in the world?

Emery: They wanted to install fear into the other people that were in these higher positions by doing it to this one.

David: So you can confirm . . . or can you confirm that that actually did happen, that that abduction happened?

Emery: That's secondhand information from two very higher-ups in D.C., and also, of course, working with Dr. Greer and The Disclosure Project and seeing a lot of the official documents that he had shared with me, yes. Yes, he is correct.

David: Wow! So are there hypnotic suggestions being planted in people's minds as well when this takes place? Are they getting post-hypnotic suggestion, things that will be cued by events that took place . . .

Emery: There are no hypnotic or mind control things going on unless you watch TV or have an iPhone or listen to the radio. So good luck with that one.

David: Ha, ha. So in your estimation, there could be subliminals that are being put out.

Emery: 100%. That's definitely happening.

David: Do you have secondhand knowledge of that, or do you actually see briefings on it?

Emery: No, I've seen . . . I was part of a project one time in Los Alamos . . . well, it wasn't owned by Los Alamos, but it was associated with a corporation there, that dealt with frequency control, mind control and cellular frequency control to make you angry or to make you sad or to, you know, manipulate you in a way that this would happen.

David: Getting back to Betty and Barney Hill, as we've drilled into this more over the years in ufology, it has emerged that he actually was testifying early along that he thought this was a military abduction. And he had very specific details.

And then, as time went on, more and more of the so-called "alien component" came in.

Emery: Right.

David: His initial impression was that it was not extraterrestrial.

Emery: I wonder why. You know, it's very realistic. You know, they have these alien reproduction vehicles. You know, we already have conquered anti-gravity for the elites.

So it wouldn't be hard for me to fly one of these devices over your house and jump out in a very expensive Hollywood alien suit and try to convince you to do what I say, especially when I have these frequency devices that I'm beaming at you that basically paralyze you or stun you for a certain amount of time while I inject you to put you out.

David: There was a particular insider disclosure about the Illuminati that I read, a very, very disturbing book called "Paperclip Dolls".

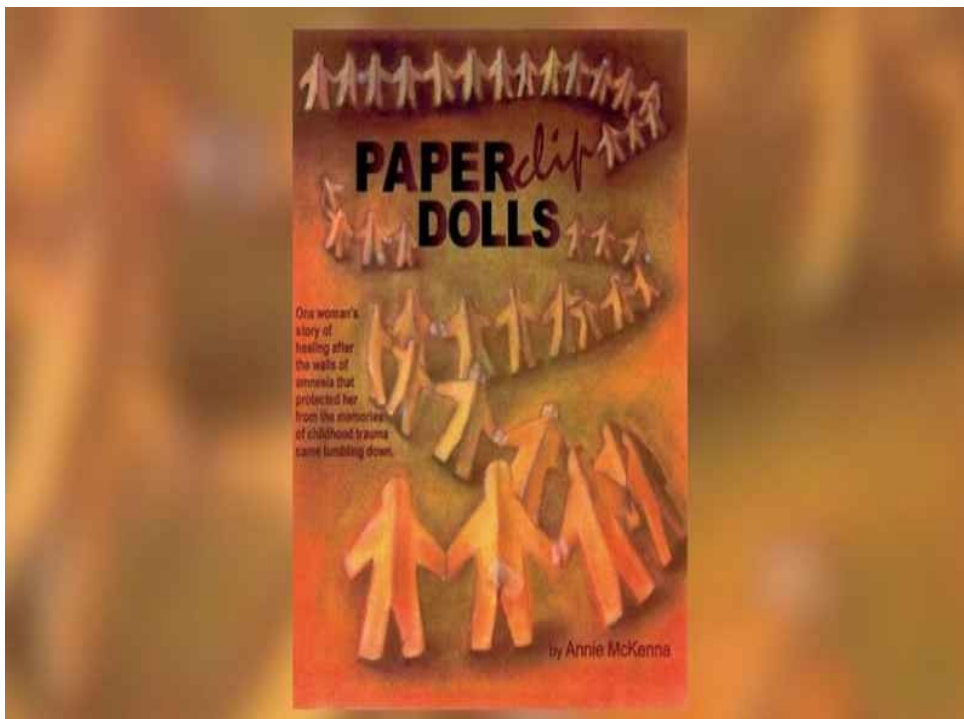

And this particular female witness went through a lot of the most savage stuff that you hear about in ritual abuse cases, but she also reported having to wear an alien suit, having to dress up in this kind of silvery alien suit with a head that looked like a Grey, and actually abuse people in that capacity.

Emery: Wow!

David: And that's in the book.

Emery: Hm.

David: So are these cases where people . . . where you could confirm that maybe in older programs?

Emery: I can confirm there's hundreds of thousands of people that go missing just in the United States alone every year, but you don't hear about it except for a couple of websites because they're the derelicts and the drug users or the homeless or the runaways.

And I do believe that these people are being collected and tested and also seeing the response and measuring the chemicals of the person while they're actually being attacked by someone dressed in a suit or something like that. Because for some reason, they're trying to figure out what kind of chemicals are released with this type of fear.

David: Could you tell us a little more about some of the stagecraft that you said is happening in these abduction cases? Like, what are we actually looking at?

Emery: Right. They don't always have to use a real craft, but it always helps. And what I'm getting at is these ARVs - we call them Alien Reproduction Vehicles – do exist.

And I have seen them firsthand.

They're not as well-created, of course, as the original extraterrestrial crafts that they try to reverse-engineer them, but they do what they're supposed to do, and that is hover and look scary. And that's all you need to see.

And then it could be done, and the next thing you know, you're kind of knocked out. But you remember that before the drugs.

So they want you to have a visual of a little guy running across the street in front of your car first, or maybe this thing that just landed in the middle of the Interstate, you know, because you'll remember that. And that's all you're going to talk about the rest of your life because of the most amazing, horrific, scary thing.

Because then you woke up in another temporary tent set up in the woods right off the street. And they're making it look like an operating room. And someone caught a glimpse of some guy carrying an M16 and a tactical vest they remember.

So it's a very classical typical thing that happens all the time.

David: It would appear that if we are dealing with a globalist organization that's doing all this behind the scenes, that they have a lot of limitations, that there is some sort of benevolent force that is stopping them from doing more.

Because these abductions are not really that bad, right? People are getting returned. They don't remember very much. They're not . . .

Emery: They need them returned. They have to be healthy because they won't be able to tell the story the rest of their life. But yes.

David: But there is some aspect of opposition to this. It's not like it's just evil.

Emery: As you notice, these abductions have been going downhill, not uphill, since the '60s, '50s.

David: Right.

Emery: And that is because of this Alliance that has been formed. You know, a high percentage of them now knows that we don't need to do this. We don't need to go this route.

And, you know, this other part of it, you know, whatever you call them, the White Hats, or however you guys . . . there's many different terms you guys use.

But, you know, we're now at the level of 90% good, 10% bad.

David: Right.

Emery: And that's going to come pretty quick here. It's going to be exposed. And the truth WILL come out about all these programs.

And, you know, the politicians are leaning more towards that because they're not taking care of their families properly. They're not protecting their families.

Instead, they're extorting them by drugging them and making them have sex with an underage person on film. And now you have to do everything I say for the rest of your . . . your . . . And you know this stuff, how it goes.

David: How do you think, or how does the Alliance think, based on briefings you've had? What will happen once they've really crossed the line, and it's actually disclosed instead of just people wondering maybe it's true?

Emery: The polls show that mostly everyone does believe in this, like a high percentage, 70 to 80%, believe there is existence beyond this planet.

David: Right.

Emery: And the problem is: how many believe they're evil and how many believe . . . there ARE good and bad, absolutely. But how many people believe what?

How many people believe that the good is trying to protect us more than evil? And how can we show that and prove that without having people come forward and talk about it and release this information?

David: I want to bring this up too, **Emery**. One of the things that we talked about, and we laughed last night, but it's come true, is that let's just say a significant number of Americans have never forgiven Vietnam.

And on some level, they're still fighting the Vietnam War. They're still listening to the music. They still worship the musicians who became famous during that time. They act like nothing else has happened that's really of value since then in music.

And we have this kind of horror of the military in America. And I think that's very sad, because like we talked about, if there was a Red Dawn scenario, if we actually had a land invasion, we lose a couple of states to a foreign invading power, . . .

Emery: Right.

David: . . . at that point, what would happen? Everyone wants the military BACK again.

Emery: Well, your attitude changes pretty quickly when you start to lose your freedom. And even though people are angry from past wars and things like this, when you come back home, it's difficult.

And when you have these old programs in you from those times with these soldiers, and I can speak because I am a soldier, you form this "against mode". "Like, that's all. That's it. Everything else is going to be bad. And I lost my faith in the government, and da-da-da-da-da."

But it does change quickly when there is a threat in your backyard: "Okay, my neighbor's playing the music really loud. What am I going to do?"

But now I just jump the fence with a 12-gauge shotgun. And he's kind of coming up to the porch. That's not normal.

So, you know, you want to help protect your home, and you want to have that fence. And that fence needs to be there, and maybe a little bit higher.

So people have a change of heart if something like that would happen, because people have families, and people don't want war. People are not born to have war.

If you asked the majority of the world without the warmongers, you know, “Do you want to go flight?”

If a human had a chance to fight or not fight, the polls show they would not want to fight – all of them.

So who's controlling all these soldiers? And who's, you know . . .

So that's kind of where it's at right now is just a bunch of puppets. And that's going to be exposed.

David: I think a lot of people feel as if the wars that we HAVE fought are wars for empire and domination to control oil, to control poppy fields in Afghanistan – that it's all about money and profit.

And there are so few people who are directly aware of the Alliance who have ever spoken out at this time.

What could you tell the people who might still be locked in this belief system that the military is just out there doing the whims of globalist bankers?

And then they would ask, “Well, if there IS an Alliance, then why haven't we heard from them?”

Emery: Well, I can assure you that that man on the front line and his commander and even that general most likely has no clue about what's really going on.

“But I'm so gung ho about my country, I'm going to do whatever it takes. And I'm going to protect it, and I'm going to protect my mom and dad and my sister and so forth.”

David: Right.

Emery: “So I'm going to do that because I'm 18 years old, you know, and I believe in this.”

David: Right.

Emery: “I believe in this.” So they made you believe in this with all of the . . . however it happened.

So now that this is coming out, the nonbelievers are going to say, “Well, where ARE these superheroes?”

And you cannot fight a war . . . You know, the war is not fought hand-to-hand combat. It's fought way behind the scenes first to control who's controlling the generals and the commanders.

David: Right.

Emery: So you have to change that first. And that's what people don't understand. It's a very delicate and very difficult situation that's going on: this little secret war behind the scenes.

But that's what changes the paradigm. That's what's going to make everything tilt.

David: It seems as if there's an astonishing lack of truthfulness in mainstream media. And that's become . . . I mean, even the polls are now showing distrust in the media is actually worse than distrust in Congress. It's lower than 12% in some cases.

So do you feel that the media is in cahoots with this globalist crime syndicate in some way?

Emery: No, I know they are. Yes, I mean, the media controls the world.

David: So with that kind of power in place, would that pose a problem for the Alliance if they were to try to let us know what they were doing right now with that much media control still in that apparatus still in place?

Emery: No, because that will be fixed. That will be taken out.

The leaders that control the media are going to have a big eye-opening problem soon. And the Alliance is working on that through the inside, actually, rather than from the outside.

So it's going to come from within. And it's actually going to have to do with also civilians, which is nice to know that people are going to stand up too and find out that, “Hey, this isn't right. We've been lied to.”

And it'll be brought to an attention in a way called “live streaming”. And no matter if it's only on there for five seconds, I can guarantee you someone recorded it, and it'll go . . .

So they would have to shut down all the main servers in those tanker ships off the coast of California, and everywhere else in the world, for that not to go viral.

And it won't be just one person. It'll be many. It'll be hundreds of people.

So that will help. You know, you have unheard superheroes on the ground. You have unheard superheroes way above. And they're all working toward the same thing, and that's to expose that problem.

David: There's been a lot of unpleasant stuff coming out about Hollywood. And I'm wondering if you think that might be part of the Alliance's plan.

Emery: Well, without mentioning movies or anything, Hollywood is also kind of controlling how we think.

David: Yeah.

Emery: But they also encrypt really cool things into it . . .

David: Right.

Emery: . . . for those people who are aware of symbology and different languages and texts. And I think that helps because I believe that's a subliminal message that things are sometimes moving to the direction that it needs to go. And that's where it's going.

And I think it's important for people to know that the message IS being sent out. If you can't see it yet, it's okay. You will. It'll be in another form.

David: So a really blunt, dumb question. Is the military working for our best good? And if so, will the abductions stop once they succeed?

Emery: Yes, the military is definitely on our side 100%. You know, these . . . The higher-ups are getting very upset about the manipulation. They have their own agents. They're starting to find out things.

So it's a very good sign that this is happening right now.

David: You've said that the abductions have already decreased a lot. Now, are you telling me that the Military Alliance people have already been fighting a war to greatly reduce how many abductions are happening?

Emery: Oh, I believe it's more of a money thing going into secret corporations. They used to use the military to help them do things, but the military didn't know why they were going to pick up . . . or going to this place and slice up a cow.

They didn't know why they were going to go pick up this individual or take part in this. They just know, "I'm there to come here and provide security."

They have no idea what's going on, and they're not allowed to ask. And if they do, then they're terminated immediately.

David: If this Cabal, as a lot of people call it – that's a term that I'm using now . . . If the Cabal is defeated, the disturbing things we've talked about in this episode with abduction, will that largely, if not completely, be stopped at the same time?

Emery: Yes, if the Cabal is defeated.

David: So in a sense then, we're having like a shadow World War III going on.

Emery: That's right.

David: And so many people are completely unaware that it's even happening.

Emery: It's right there in front of your eyes if you really think about it and look at what's going on around the world. But, you know, we don't have time for that.

And it's not the people's fault.

David: Right.

Emery: “I have to work. I have to eat tonight. You know, I have to do these things. I'm in the Matrix too, guys.”

David: Yeah.

Emery: So, it's like, “What am I going to do? Okay, I'm going to conform too.” We all have to conform for a little bit, but now it's time to give back a little bit.

David: What do you think the world will look like once we get Disclosure and the Cabal's defeated?

Emery: Overnight, it will change. The devices of all the technology they've been hiding will come. The world will flourish. It will be full abundance. No one will starve.

It'll be clean water for everyone. It will be homes for everyone, and the world will come together as one, and everything else will be left behind.

And the old paradigm . . . We will forget about our religions and all that, because, you know. all of this is getting exposed too at the same time.

So it changes how we were kind of tricked since we were born.

David: Right.

Emery: And now the truth is here. And now everyone will apologize, and it will be beautiful.

David: Well, **Emery**, I want to thank you for being here. And I want to thank you for watching. This is “[Cosmic Disclosure](#)”. I'm your host, [David Wilcock](#), with our special guest **Emery** Smith.

[Cosmic Disclosure: Hybrid Creatures and Secret Bases](#)

Season 9, Episode 9

David Wilcock: All right. Welcome to “[Cosmic Disclosure](#)”. I'm your host, **David Wilcock**, and I'm here with **Emery Smith**.

So we were talking about this concept that you weren't that surprised by the idea of very elaborate genetic hybrids being made by our government, even at the beginning of this time that you spent at Sandia Labs inside Los Alamos.

So I kind of feel like there's something missing here. How much had you been briefed on genetic hybridization programs before you ever started this particular job with these so-called “salmon filets”?

Emery Smith: Yeah, I was not, actually. I was a very low-classified individual at that time. So it actually didn't happen 'til about a year or two later, where because of what I was dissecting, or whatever, led to other briefings that led to other briefings, because a lot of these beings were connected to ships.

And when I got pulled into that, then I was pulled into other things that had to do with hybridization, because I was actually told once that one of the samples WAS a hybrid, and that's how I knew they were doing hybridization.

They didn't hide it that time and during the briefing, . . .

David: Wow!

Emery: . . . and it was a group briefing, so it was exposed.

David: And what was this sample? What was it a hybrid of? What did it look like?

Emery: It was kind of like a tiger. It was a tiger-type, human-type being.

David: Really?

Emery: Yeah. The DNA had a fur on it. It was very humanoid and only stood about five feet tall.

And it was very . . . The way it looked was very dismantled. It was not correctly how you would think you would see something like in a movie or something where it has the perfect eye set - the nose is perfectly aligned. It was dysmorphed very, very horribly.



And I don't know . . . I cannot tell you what DNA were used to make this creature. I could just tell you what it looked like. You understand what I'm saying?

It had the aspects of a cat face like a tiger, and it had very large green eyes. And it had whiskers, and the body was very small and very frail. And it had just regular fur.

David: Well, we have seen cases of people trying to breed lions and tigers together and different types of things. And I remember noticing that in some of those cases, those animals have this kind of disabled look.

They get these strange deformities to their faces . . .

Emery: Right, I heard about this.

David: . . . and things like this.

Emery: Right.

David: So, do you think this was a failed prototype idea of some kind?

Emery: Yes, absolutely. I think it was a total failed prototype, because I don't know what that would serve – what they were doing.

I think they were just trying . . . which they have already been doing for many years I know before I even came along because of some of the things that were released to me later on in the projects. They were mixing all sorts of DNA with human DNA, including plant DNA, and mammal DNA from other mammals from the oceans and sea.

David: What do you think this tiger being could have been used for? I mean, I know it's speculation.

Emery: Well, speculation for me: total military type, operative-type, super-soldier-type programs. Just as in the old days, they would . . . and the Roman Empire have mastiffs, hundreds of them.

They found hundreds of mass graves at big sites where they would be running alongside the horses, and the mastiffs would jump on the people, and the horsemen would spear the guys. They were just used to knock down people.

So this was probably used to - maybe some future war or something – to release all these crazy hybrid-killing machines instead of using humans, of course. first . . .

David: Right.

Emery: . . . and THEN send in the humans. Or send in . . . Of course, probably in the future, I'm sure it's going to be mostly clones and drones that will be . . . The war will be fought inside a computer room.

David: I kind of asked you this before, but I'm curious to get it in a little more detail.

You said something about that the clone might have memories loaded into its mind . . .

Emery: Yeah.

David: . . . so that it believes that it has an identity that's lived for however many years?

Emery: Yeah. They can program the brain, because the brain is just not its own brain. It does have modulation to it using very, very small sensors, and . . . how can you say this . . . wiring.

David: Implants.

Emery: Yeah, implants, that stimulate certain parts of the brain.

David: Okay.

Emery: And they can also download it and make you believe that you are Marilyn Monroe or you are [David Wilcock](#), or you are whoever, and this is actually what has happened to you in the past 25 years.

And you just wake up in a bed one day going to work, or someone's picking you up, and that's all you will know.

David: Is it possible to store someone's memories and personality on a hard drive actually as a data storage?

Emery: I haven't seen that. I get that question asked a lot, because of the movies out there - "Avatar" - and thinks like that, the consciousness.

David: Sure.

Emery: But I have not seen that, because you would have to have the DNA. All I know is that you can only do it if they have your DNA, because the DNA IS EVERYTHING enfolded within the universe, including your specific matching prototype of who you are and all the conscious experiences you have.

So I'm sure by now they probably have something that can store your DNA for a very, very long period of time without damaging that part of it that keeps the conscious memory implanted into it.

David: One of my other insiders reported working at a base which seemed to be Area 51, though he wouldn't say that. I think maybe at one point he did. He said "S4", which is Area 51.

And he reported that they had a dog that was, I guess, a desert dog that showed up, and the dog started to have certain quirks and certain tricks that it learned.

And then the dog died, and they cloned it because they liked the dog so much they wanted it back.

And they discovered that each clone had the memories of the preceding dog as well. And so, it was as if

. . . they started to conclude that the DNA was simply some physical address for an energetic consciousness that superseded DNA.

What are your thoughts on that?

Emery: No, I agree with that. The DNA is just our 3D interpretation of the energy that is you. So the light body, I believe, and all that, is stored.

We call it DNA because it's what we're taught in science, but really, it's in the field of that molecule or whatever you want to call it – a tetrahedron, or however, . . .

David: Right.

Emery: . . . what your belief system is.

David: Yes.

Emery: So I do agree it is an energetic thing.

David: So he referred to the DNA, and they apparently refer to it, as like a tuning fork . . .

Emery: Right.

David: . . . that it tunes in this energetic aspect of yourself.

Emery: Right. It's a radio. That's correct. It's a type of a device, kind of.

David: So how does that interplay with programmed memories? How could they give you a memory that you didn't really have? Or is it more that they can make the clone THINK that it's you and access your own data bank of memory?

Emery: Yeah, they have a . . . I wasn't part of that program, but they do have something that does exactly what you just said. It somehow gives that DNA or that energy frequency.

Like when you talk about the morphogenic field: everyone's everywhere, everything is everything. So that energy somehow . . . You know, if I want to believe . . . If I have an affinity to be you, I will believe I'm you, and I AM you, because we're each other. We're everywhere.

And what happens is I think they have somehow, someway, found a way to change that memory of who you were in the DNA using that exact thing you said: a frequency in this field.

And that's just my speculation.

David: I did hear from my Secret Space Program insider, Jacob, who is very deeply involved on many, many levels, claims to have been to, I believe he said, over 2,000 off-planet locations through portals he claims that he went to. And he was very credible.

He said at one point that certain elite people could have . . . There is apparently a machine they have where they can download your personality and consciousness into a younger version of yourself, that you can be transferred . . .

Emery: Right.

David: . . . from one body to another as your main host body. Do you know anything about that?

Emery: I do not know anything about that, but I have seen them do that with other beings.

David: Really?

Emery: Yeah. So I'm assuming 100% they can do that just through some of the briefings I've been in on of similar consciousness movement of what you call this downloading of your own personality field.

And so there's no doubt in my mind. I believe that is true, but I have not seen that.

David: What is the reason for why these cloned beings seem to have a shorter lifespan?

Emery: I think any time you take any type of cell . . . like we have problems with stem cells right now. When you take them and you multiply them, there is a couple of them that come out not too well.

So the more you do it, sometimes you have a little bit more problems with the cells being mutative. They start mutating into different things, not what we thought they were going to be.

So there must be something in the field that only allows us to maybe . . . or we just haven't perfected it here yet, because I know it's been perfected up there.

So I think it has something to do with that. Maybe it's not supposed to be done, and that there's an unhealthier clone every time you clone someone – when you do it that way.

David: If we go back to some of the vintage whistleblowers like Bill Uhouse, it appears that from whoever, and it might be the Cabal, a narrative was presented with the idea that the Greys are humans from the future who had their population greatly reduced after a catastrophe, and that they now have been cloning themselves. And it's like multiple photocopies, it starts to get damaged, that this funny thing they do is diabetic neuropathy.



It's the neuropathy from genetic cloning, and that they're coming back to do these abductions to try to bolster their genetic stock.

Why do you think that kind of a narrative would be created if it's not true? What would be the objective there?

Emery: I couldn't comment on that, because I don't know of this exact story.

David: Okay.

Emery: I could just tell you that if they're real extraterrestrials and they're cloning each other, they're probably pretty perfect specimens. And they would have already figured out how to fix those mutations 100%.

If they're not real specimens, and they were escaped hybrids that formed their own . . .

David: Ah!

Emery: . . . and got smart enough to learn and form their own civilization up there and want to take over Earth or something, then that would be a possibility that they're failing.

David: We have seen a lot of reports, if you go back again into more vintage ufology, of people describing something called a “neonate”. And that is where, if a fetus is allowed to develop without the pressure of the womb around it, that the head will largely increase in size, and you will end up with a being that will retain fetal proportions into adulthood, which is exactly what a Grey looks like.

So some ufologists have speculated that Greys could be humans that simply have been grown in some kind of a vat or a tube instead of in a womb. What are your thoughts on that?

Emery: Yeah, it is a possibility. A lot of these extraterrestrials could have hybrid human DNA in them for sure and vice versa.

So I definitely believe in that, because it's been done. It's been done.

David: Were you aware of any other being like the tiger-human hybrid that was a hybrid program that you were directly briefed on or allowed to see a specimen of?

Emery: No. Other than that, there was one that was kind of like a manatee-type version.

David: Really?

Emery: Yeah, a manatee-type, walrus-type, seal-type phenotype there that they were utilizing that had a very, very weird look to it. [It] also was disproportionate and was dead upon seeing it.

I believe that was part of a project where they were mixing mammalian with human DNA.



I don't know what they were going to do with it, but it looked like a manatee but upright with arms and hands.

David: Well, just to follow on that for a second, are you familiar with there being any bases that our government or the Cabal might have that would be under the ocean?

Emery: Yes.

David: And how would that work based on what you know? How would you build a base at the bottom of the ocean, let's say?

Emery: Well, there's bases that were already there that they took over that have been here for millions of years that were already functional, and they found these bases in different parts and different areas.

And most of the bases are not just like bubbles on the bottom of an ocean. They're actually under the ocean's crust.

David: Right.

Emery: So that's how they really bore in there. And they build it from underneath up. They don't go down from the surface of the ocean with a bunch of two-by-fours and steel parts.

It's a very complex, very advanced way to make an underground sea lab.

Sea labs exist all over the world.

David: That's what it's called: a sea lab?

Emery: Sea labs, yeah, are all over the world.

David: Okay.

Emery: Very small. You might see a small one on the bottom of the ocean, but underneath that is really where the base is.

David: Huh.

Emery: It's underneath the crust of the bottom of the ocean and the rock.

David: So by digging down first and then working from the bottom up, does that prevent against erosion and cataclysms and that kind of thing?

Emery: I think it's probably the safest way to do it without being noticed.

David: Ah, right.

Emery: You know, it's a secrecy thing. After what happened many, many years ago with the Taos Hums, they were worried that people were catching on with what they were doing with making these tunnels, but now they're using a different type of technique.

Of course, as you know, they make big lava tubes and melt rock, and they don't use the old-fashioned drills. You see these pictures of these ancient drill bits that are like 150' in diameter.

David: Right.

Emery: That's old school.

David: Some skeptics might say that we barely even have the ability to get any submarine that far down. The pressure would crush any type of technology.

So how have they overcome those limitations of the pressure?

Emery: Oh, no. They don't use submarines. They use our own alien reproduction vehicles.

We form our own gravitational force. We're inside our own gravity field, so we cannot get crushed.

We form . . . That's why you can go to space, and that's why you see some of these UFOs and these other ones just go right into the water and keep going, because they're in their own environment and their own gravity. So it would be easy for them to transport people or equipment or whatnot.

But they always have a direct link to these tunnels is what it's all about, and there's many tunnels all around the world.

David: And there's pressure that . . . They can generate enough gravity that they can easily counteract the pressure of the ocean?

Emery: Oh, absolutely. Of course, they can transdimensionally change the size of themselves.

David: Like how would that work?

Emery: Well, they kind of dematerialize, but you're still there but you're just out of this frequency just a hair, so you don't fall under the laws of the science of this planet.

David: Hm.

Emery: And that is for every other planet. That's why they can go anywhere. They can go right through the Earth.

You can fly right . . . In the craft, I'm going towards the tree, because that's where I want to go. And as soon as I see the tree, the craft changes interdimensionally. It can shrink itself or change its frequency

just a little bit different so the structure of it will just go through it or around it. And that's exactly how they do it.

David: Do you think that these manatee people could possibly have been bred to be able to do work in the ocean?

Emery: No. I think they were . . . that was just a scientific experiment gone bad. I think they were trying to . . . They were probably looking at other more intelligent mammals, but they were starting with different ones. I don't know why they picked that. I couldn't even tell you.

I've been saying what it looked like. I don't know if it was manatee DNA. I'm just hypothesizing because of the way it looked – like this type of face and the skin, and it was very interesting.

Now, there are dolphin-like extraterrestrial-type people that have evolved beyond us that have come back and dropped off their lineage of dolphins here.

David: It does seem interesting to me, **Emery**, that in the early, early maritime era, there were sightings of people claiming that they saw human aquatic hybrids of some kind.

And that almost universally is written off as if the sailors were just drinking or something . . .

Emery: Sure.

David: . . . or that “Oh, they saw manatees”.

Emery: Right.

David: But yet, you've seen line art illustrations of people who drew these things from the craft. And you see, for example, a being that has a human face, but it almost has flippers coming out for arms and flippers coming out for legs, almost like it's a scaly type of thing as well.

Emery: Right.

David: So do you think that maybe at that early era before we really started to explore the oceans that these ETs had more free will to be in our oceans without violating our free will?

Emery: Yes, yes. I believe many thousands and thousands and thousands of years ago that there was a race of extraterrestrials that lived in the ocean and have maybe even migrated into Inner Earth oceans now.

David: Hm.

Emery: We refer to them as the “Aquifarians”, . . .

David: Really?

Emery: . . . and they come from another water planet. And there actually are many different water planets.

I'm not sure too much more than that about them, or how they live or anything, but I just know about that because I have seen some briefings of this race, and I've also physically seen things in the ocean that resemble these types of beings.

David: Hm! Wow! What exactly does it look like? Could you be a little more specific?

Emery: Yeah, it looks like you said. It's a human form, and it's fishy. And it's [got] a very beautiful face with long, long hair.



There are men and women of these types of beings, and they can walk. They're not like the mermaids we see with these fins, but they do have fins on the outside of the body, kind of like a cuttlefish.



You know what a cuttlefish is?

David: Yeah.

Emery: They have these fins around the outside of the body that allow them to propel themselves very, very fast. And they're very strong, and they're very tall beings.

David: Well, one of the things that is very interesting to bring up here. Having traveled in Japan for 3-½ weeks, there are very, very extensive records of a being called a “Kappa” - K-A-P-P-A.

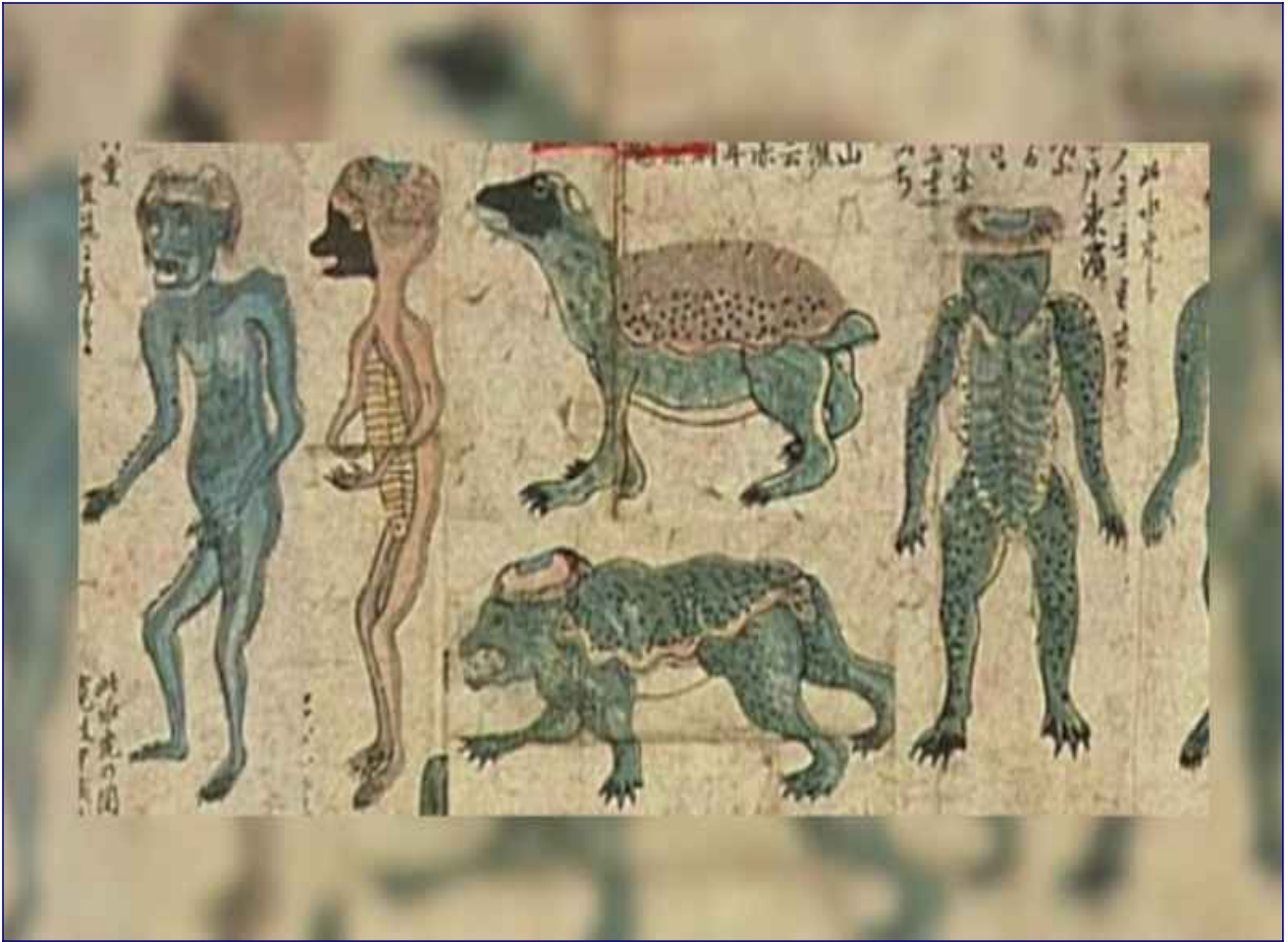

And this is essentially an aquatic humanoid. It's intelligent. It can speak our language. And they would actually abduct and kill children, so children were always warned not to go near the water because of the Kappa.

But sometimes the Kappa would come out, and they would taunt people. They would talk to them. They would make jokes. They would make rude noises.

And the other strange thing about the Kappa – just to finish this off – is that apparently – and this is very consistent of all Japanese reports – that they had this indentation on the top of their head about one cup size, and that they needed to have water in it.

And that if the water fell out . . . Like if you could convince them to bow down like this [**David bows**] and the water comes out, they would actually die very quickly if they couldn't get back to the water.

Emery: Hm.

David: This is a widespread Japanese legend.

Emery: Wow!

David: So what do you think the Kappa might be, just speculating?

Emery: You're talking ancient times, correct, because . . .

David: Not really.

Emery: No? Because this . . .

David: Maybe only a few hundred years ago.

Emery: Yes, because this definitely sounds like a kind of hybrid-gone-wrong-type situation because of the water . . . what you mentioned about the water.

There's many things that they make to try to live on the Earth, but when you start mixing DNA, especially with aquatics, it doesn't work out too well because of the oxygen and the water that these beings need to survive.

You know how fish have gills and sharks and whatnot? And they rely more on these other animals that can gulp air and hold their breaths for 24 hours, you know, . . .

David: Ah!

Emery: . . . like certain kinds of catfish and salamanders and whatnot.

So I think I don't know anything about that story, but it does ring some bells on some other projects that have gone wrong as far as trying to keep beings that they make be able to be in the water AND land. That's the super-soldier being: to be able to go there, to be able to survive the vacuum of space like some organisms we have here, and to be able to survive on its own without help, but to be able to be controlled.

David: Do you think that there are Earth-like planets that are water worlds that don't have land that comes above the surface, and the whole planet is an ocean basically?

Emery: I believe in that definitely, yes.

David: Okay. So is it possible that a humanoid intelligent species could evolve on that planet by evolving in the ocean?

Emery: Absolutely, yes.

David: Now, the funny part was that I've watched some scientists speculate on this. And they said, "Well, intelligent life couldn't form in an ocean because they'd have to be able to make fire, . . .

Emery: Ha, ha, ha.

David: . . . and they couldn't burn anything in the water."

Emery: That's pretty ignorant.

David: Ha, ha, ha.

Emery: We have a lot of species here that are living quite fine that are more conscious than we are.

Just because we can't communicate with them doesn't mean we should alienate them, just like dolphins.

David: Right.

Emery: I mean, their brains are a little bit bigger than ours. And that's the whole thing with everything else is about communication.

It's so said that just because we can't communicate with someone that we have our differences, or we make them look like they're smaller than we are. That's something that needs to go.

David: Why do you think the Kappa might have died if the water fell out of this little cup in its head – this cup-shaped indentation?

Emery: I would say it has to do with voltage, because of how the salt water of the body can't have a special voltage. And I think he needs the voltage to keep running in the body.

David: Hm.

Emery: I don't believe it has anything to do with breathing or anything else, because they would not have risked that to come upon the shore.

David: Right.

Emery: But that voltage . . . Because every living creature gives off a type of voltage or a frequency, and it's alive.

David: Now, we've heard a lot of reports about the Philadelphia Experiment. And then when you get into the scientist Gerry Vassilatos, he reported that at Norfolk Naval Shipyard they were doing these major welding operations for battleships around World War II.

And that when they did the arc welding, they would see this huge flash of light, and then all the power would go off. And they couldn't understand why this was happening.

And eventually, they do a high-speed film, and they found that this hole would appear – like a black hole – and tools and objects would be flying into the hole before the power shut down.

And this, apparently, was what led to the development of the Philadelphia Experiment, where allegedly a ship was transported from Virginia up to around Philadelphia – hence “Philadelphia Experiment” - and then back to Virginia.

Are we looking at, do you think, an early prototype example of what later became a portal technology where all the kinks got smoothed out? Is that what the Philadelphia Experiment might be?

Emery: Portals exist. There's a lot of science into portals that we have done without using certain Earth grid points.

As far as that specific, I would have to know a little bit more information of what they were using to weld and a lot of the energy going into that and the fields of electromagnetic energy.

David: It was very, very high voltage electrostatic welding.

Emery: Perfect. Well, that's what you need to do that. So it could very possibly be that that's how they were teletransported to the other side or had a device to do that.

David: Why do you think the soldiers ended up getting embedded in the hull of the ship as was reported? What might have caused that to happen?

Emery: Oh, just a glitch in the system. It happens all the time. We lose lots of people in portals.

David: Really?

Emery: We haven't mastered it very well.

David: We still haven't mastered it very well?

Emery: No, we have not.

David: Hm.

Emery: It works. We've done it, but it's not 100% safe.

David: Wow!

Emery: But nothing is, like driving a car.

David: So another thing that you told me that I thought was really interesting – and I feel like it's a good time to touch on this – is you mentioned to me in private conversation that the locations of where we chose to build military bases might not be totally arbitrary.

What are some of the hidden reasons for why certain bases are where they are?

Emery: Well, not all the bases, but a few bases, like I told you earlier, were built on certain grid points on the planet because they were built on top of other ancient bases that were there.

David: Hm.

Emery: And some of those ancient bases already had working energy devices and alien craft and portals.

David: Hm. So they would literally be able to just dig right down into that base and re-occupy it?

Emery: Well, not re-occupy it, but study it and reverse engineer it. And, of course, if they were building certain portals or certain other devices, they would make sure it was put on that same grid point or try to activate certain portals that are there.

In the early years, you know, in the '40s, '50s, they were . . . when they had a lot of bases going out

west and stuff and exploring things using special radars to look underneath the Earth, which have been improved today, they would pick these specific points.

And this is where they would set up labs. Like Sandia Labs is actually on Kirtland Air Force Base; Los Alamos Labs is north of that, but they're all connected.

So I do believe around the world, not just here, but also military bases in other countries, after looking at them and lining them all up, DO fall on interesting grid points. And there have been many spectacles of different phenomena that comes out of these bases that are witnessed by civilians in these specific points.

David: So you're saying, then, that in certain cases a military base might be built over a wrecked extraterrestrial vehicle that's underground somewhere?

Emery: Absolutely, or a base that has already been there from ancient times or from extraterrestrials that abandoned it.

David: This does line up with some other intel that we got from other folks.

So are there certain cases where the craft itself would be very large – like very unusually large?

Emery: VERY large, absolutely.

David: Okay.

Emery: I mean, Kirtland Air Force Base is the fifth largest land base in the world, and you have to look at a lot of different parameters when you're trying to associate and balance all the different bases. And if you're really into this kind of thing . . .

And, you know, there's craft that are very, very, very, very large that's stuck in the crust of our Earth. And I've seen the photos. We use a very special type of radar that's classified that's 400 times more greater resolution than a CAT scan.

David: Wow!

Emery: And it has a backflow of frequency energy that measures the time of how that frequency comes back to tell us exactly what it was to build a volumetric image.

David: Yeah, and you actually showed me some of that. It's probably not for public distribution, but you showed me some very, very interesting stuff at one point of what appears to be an underground site that is definitely not known to the public.

Emery: Yes. Right. Some of these craft can be anywhere from 8' wide to 33 miles long.

Some of the structures underneath the ground could be just as big – 10 times larger than the Giza pyramids.

David: But are pyramids in some cases?

Emery: Right, . . . Yep, in that kind of shape.

David: Wow!

Emery: Or reverse pyramids, like tetrahedrons – one on the other going backwards.

David: Interesting.

Emery: Yeah, very amazing shapes and very deep in the Earth and with many things inside them.

David: So let's say we have, as one example, a 33-mile-wide craft underground.

Emery: Sure.

David: How many staff might be dedicated to exploring just that one thing, and for how long might that have been happening if you say an entire base is built there where the good stuff is?

Emery: It could take many, many, many, many, many, many, many, many years for that to . . . It's not like you just break into a tomb, and there's the mummy, and okay, and everyone just pillages it or whatever.

They're very careful with it. And just like in Antarctica with what's going on down there, it would take a team to probably research that kind of base – I'll say it's a craft; I'll say base underground – depending on how many parameters: like how deep it is, what kind of rock is in it, how we're going to get there.

The biggest thing they'll do first is all this volumetric imaging. And then they'll plan out, and they'll recreate it on the Earth first.

So they'll actually map whatever they see and make a model of it, exact spec, on top of the Earth, or under a ground base where they can do this secretly, to see exactly what's there.

And then, of course, it's not going to be . . . So when the team goes . . . Now they're using virtual reality to do it.

So when the team goes in, they know where they're at inside this area of the craft or whatnot. You know, is there still energy there on the craft? Is it still on?

Is there beings there? If they are, are they alive, or are they in a cryo state?

These are the things that they do. So they're very, very specific about . . . before going in and just digging everything up. It's not like this general saying, "Get in there and just dig this sucker . . . Get all the backhoes and do it."

It's more like . . . It's very calm. "Let's figure this out first. This is very dangerous. We don't know what we're getting into."

You know, you have to understand there might be microbes in there that come out and infect the entire planet, so vacuum tunnels have to be made with negative pressure air systems and stuff.

So it's a very dynamic and a very huge undertaking. It could take 20, 50, 100 years to do a project like that with all those parameters I said that are involved.

David: Well, I would be remiss to end this episode without just asking this quickly, which would be: Are you confirming the presence of at least one very large mothership under the ice in Antarctica?

Emery: Yes.

David: Okay. We have got a lot of other testimony on this – from **Pete** Peterson, from **Corey Goode**, other insiders I've spoken to as well.

You and I have actually never even spoken about that, so it's kind of amazing that you would have heard about this as well.

Emery: You know, it won't be the people. It won't be us exposing this. It's going to be Earth that exposes it because of the warmth.

They can't fight the heat right now. And since they can't fight the heat, it's going to be really hard to explain when some of the snow melts in the next year, and this giant thing starts being exposed and different metals.

David: Wow!

Emery: So Gaia will be Disclosure. Earth will be the one who discloses it, which is beautiful.

David: Well, we're going to help Gaia.

Emery: Yeah, we're going to help Gaia.

David: Gaia's going to help Gaia.

Emery: Yeah.

David: Ha, ha.

Emery: But you get what I'm getting at. Isn't that beautiful?

David: That is amazing! All right. Well, I didn't want to leave it on that cliff hanger. We'll be back next time. "[Cosmic Disclosure](#)." I'm your host, **David Wilcock**, here with **Emery** Smith. Thanks for watching.

[Cosmic Disclosure: Secrets at the South Pole](#)

Season 9, Episode 10

David Wilcock: All right. Welcome back to “[Cosmic Disclosure](#)”. I'm your host, **David Wilcock**, and I'm here with our special guest, **Emery Smith**.

Emery, thank you for being here.

Emery Smith: Thanks, Dave. Appreciate it.

David: In our previous episode, we talked a little about how military bases are being built over extraterrestrial bases or crashed craft. And we had started to talk a little bit about what you may know regarding Antarctica.

So just to get more specific with you, according to **Pete** Peterson, operations in Antarctica have been ongoing for quite some time.

He was aware of it being back to at least the 1950s. And he said that it is a truly vast operation that's being conducted down there.

So could you speak a little bit more about what you know of what's going on in Antarctica?

Emery: I have recently met with four of the scientists that were part of that expedition, well, many expeditions in the past few years – in Costa Rica recently.

And what was interesting is there's also another craft that is part of some of the craft that's down THERE [Antarctica] in a cave down near Costa Rica, I'll say.

David: Oh, wow!

Emery: And so this group was asking me to come with them to Antarctica to check it out on another expedition, which I refrained to go because all newbies don't return.

David: Really?

Emery: So that's how dangerous it is.

David: Hm!

Emery: And any people that go down there to do documentaries or try to get with people to take them down there usually end up pretty much not coming back.

David: Wow!

Emery: So right now, if you don't have a specific, really good classification, you're not going down there.

So that does leave it open to satellites, however, and special drones that we have access to to find out more information.

Different organizations are funding this, private organizations, because the people want to know.

And so this information was given to me strictly from the four scientists that actually came from working there for two years, which they do have the access to get back down in there to do what they do, which is basically . . . Well, I was talking about mapping and measuring of the melting ice and how much time they have before other things are exposed, which lead to the exposure of the underground city that's there that has been there for a very long time, apparently.

David: Are you familiar with there being any plan to reveal ancient ruins under the ice in Antarctica, but not spacecraft at first or anything more modern, as part of a gradual disclosure agenda?

Emery: They already started that. So they're saying there's something down there, a big void, just like they did in Egypt now. There's a big void underneath the pyramids there.

We have a very, very large city that's there.

David: In Egypt?

Emery: In Egypt, under the pyramids, about a mile high dome.

David: Really?

Emery: Yes, it's very large.

So this is the same thing that's going on in Antarctica.

So they're slowly saying, “Wow, through satellite imagery with special ground-penetrating radar, certain scientists from . . .”, which have nothing to do with trying to find bases, by the way – more like trying to find oil reservoirs and gold – have stumbled upon these giant voids. So you're going to start hearing about this.

These voids are the ancient cities. You know, these are the ones that have been here for a very long time. This is right up your alley with all the stuff that you talk about.

And there has been great camera footage taken from an archaeologist that we know. And we have seen this footage. And it is compelling because the camera they snake down under the pyramid to see this, when it first was discovered, which I cannot disclose, was just fascinating.

David: Hm!

Emery: So the same thing is going on in Antarctica now is: how are we going to disclose this and clean up all the artifacts down there, which will really mess up the story of how we got here . . .

David: Right.

Emery: . . . kind of like Mars and the Moon and everything else. And it's right here on this planet.

David: All of a sudden in the media, we hear this report that neutrinos were used to discover a very large new chamber in the Great Pyramid above the Grand Gallery, which is the big hallway with the tall . . .

Emery: That's right.

David: And they're kind of saying it might be on a diagonal with the Grand Gallery, . . .

Emery: Correct.

David: . . . but it's a little higher.

Emery: Right.

David: And that's a very large, previously undisclosed space.

Particle physicists discover mysterious structure in Great Pyramid – here's how they did it

November 2, 2017 10:11am EDT

Khufu's pyramid is the largest in the Giza pyramid complex. [Photo: iStock.com/sergey_001](#)

- Email
- Twitter
- Facebook

Particle physicists have uncovered a large, hidden void in Khufu's Pyramid, the largest pyramid in Giza, Egypt – built between 2600 and 2500 BC. The discovery, [published in Nature](#), was made using cosmic-ray based imaging and may help scientists work out how the

Author



Harold Fox
Senior Lecturer of Particle Physics, Lancaster

How cosmic rays revealed a new, mysterious void inside the Great Pyramid

This tantalizing finding raises more questions than it answers.

By Brian Resnick | [@B_Resnick](#) | [brian@vox.com](#) | Nov 2, 2017, 9:11am EDT

TWEET SHARE



It's not ancient aliens. | [GizaPyramids](#)

Today, the journal *Nature* has **published** a finding that sounds like the setup to a Nicolas Cage movie. A team of physicists and engineers has discovered a previously unknown "void"

Emery: I've heard about that.

David: Now, with the technology you're reporting, it would appear that they would have known about this for a long time.

Emery: Oh, they've known about it for a very long time.

David: Have people been into that room that you know of?

Emery: Yes.

David: Really?

Emery: Yeah. And that's what the Alliance needs to decide is: what do we release and how slow do we release it? So there's a gradual scientific, huge, worldwide, scientific investigation of these tablets or this or that or whatnot, because it doesn't match what's going on or what we've been taught here.

And that's going to be the hard thing for people to grasp because of the belief systems that we all have.

David: Do you think that there might be a way . . . I mean, they don't want to tear up the pyramid, right? They're very concerned about antiquities preservation. But now we're talking about a massive, massive chamber inside the pyramid openly discussed in mainstream media.

Emery: Right.

David: So is there a way into that room already? Do we know what's in that room?

Emery: I'm 80% sure they've already been in that room from the bottom up. There are tunnels that they have already dug under into this city, so it's already been . . .

David: Wow!

Emery: They're learning what happened. You know, they're trying to learn the texts, learn all the symbols, and what's it all mean?

And so it's a huge undertaking on the private side of whoever is running that contract job. I can tell you that much.

David: Just for the sake of people's curiosity, what might be some of the most surprising things that we would learn?

Like, what would we actually see if we ever get to see the footage of this room? What would be the most surprising thing we would discover?

Emery: Well, you're going to discover a lot of literature and tablets, and also artifacts that are not from on Earth – not of Earth-origin technology – which most of it has been removed.

David: Wow!

Emery: Whether they want to say it was found with the site or not, it will be a spectacle because it has to do with someone already being there trying to do the same thing we were doing about a higher, advanced civilization, and they left some things behind.

So there's special scientists in the world who grab these devices, and they can figure out what the devices were used for. That's what their job is to do.

And they're really interesting people, and they're responsible. They're the unseen heroes you hear about.

But a lot of the information that they get is usually used to give to these private corporations to be used for bad because it's so amazing. Why give it to us to help us cure cancer or be able to talk to anyone in the universe?

David: I want to bring something up with you that I think is directly relevant, and that is an insider that **Pete** Peterson has hoped to get me in touch with – it hasn't actually happened yet – but this person was involved in the excavation of a strange sort of metallic alloy sarcophagus from this same Giza Plateau area. And I believe he said it was underground.

And they removed the sarcophagus, and they had it . . . They were trying to figure out how to get it open, and they couldn't open it with tools.

And apparently on the ship – they were transporting it on a U.S. military ship of some kind – someone telepathically interfaced with this sarcophagus, and they could read the inscriptions. Even though

originally it was a different language, they could read the language.

And then they had to sing a certain note or phrase. I can't remember which it was . . .

Emery: A harmonic, yeah.

David: And you put your hands out like this and it opened.

And then what they found inside were these various kind of hand-held tools. And some of the tools, apparently, would give you holographic reconstructions of historical events that happened during the time of the people that had this thing.

Emery: Sure. Oh, yes.

David: And that sarcophagus alone is just of inestimable value. Have you ever heard any stories like that?

Emery: Yes, I have heard of very similar stories of these sarcophagi and coffins and tubes that are made of some unknown metal but they're seamless.

David: Wow!

Emery: And they can only be opened, as far as I knew, by lineage, actually, and harmonic. So that's interesting you said that, because it actually helps me understand some things now put together that I've been debriefed on.

And I've seen some of these vats, actually.

David: What about this idea of an object that you might be able to hold in your hand, and then you can kind of talk to it with your mind . . .

Emery: Yes.

David: . . . and it will show you, like, a library?

Emery: Absolutely. It's a consciousness-assisted technology that you have to hold and use your consciousness. You know, you have to think about it, and then whatever, however it operates – however, the operator knows how to operate it.

Or usually, it just automatically will turn on. You know, it's like having an iPhone without a passcode on it. Automatically anyone can use it.

But some of these devices, these consciousness-assisted technologies, are all lineage-related or frequency-related, so that you have to be of the right ancient lineage to hold that one little frequency for this thing to work.

David: A genetic marker in your DNA, do you think?

Emery: Yes. Yes.

David: Wow! Really?

Emery: Yeah.

David: When we had **Pete** Peterson here last time, he gave us some extremely fascinating information about very, very long – many, many miles long – perfectly carved tunnels in South America, like, underneath the Nazca Lines.

And he talked about what appeared to have been a vast extraterrestrial city down there. And, of course, with our show on Gaia, “Unearthing Nazca”, **Pete** is claiming that the bodies we had on that show were from this city.

So I'm curious if you've heard about those tunnels in Meso- and South America, and any information you might have on that.

Emery: Yes. My scientist sources also have invited me down there to analyze the tunnels, which have a lot of craft in them, which have . . . The tunnels actually have beings frozen in time sticking out of the walls of these things.

David: Have you ever heard the term “stasis beings”?

Emery: Yes. I mean, I don't personally believe these beings that come from Gaia are from that site.

David: Okay.

Emery: But that's my own opinion. And I have not been asked to analyze these beings yet.

David: Okay. So you're saying that there are . . . This is totally amazing, **Emery**. I'm just going to be honest with you. And the reason why is that I got another briefing from **Pete**. I haven't said a word about it to anyone.

I'm going to do it for the first time right now, okay?

And the briefing was that, because Gaia did “Unearthing Nazca”, the show, that our Alliance people have gotten a lot more interested in that area again, and that apparently the Mexican government . . . We have the Peruvian government . . . We have different governments in Meso- and South America, apparently involved in this.

And apparently, very recently, we took custody of these five different craft, and he said that they are so advanced that we've got whole teams of people . . . He estimated 2,000~3,000 people are working on these craft now. But it's so advanced we have no idea how to get into it or what the heck is going on.

So I'm curious about your thoughts on that.

Emery: Yeah, I agree with that. But when you say “we”, who are you referring to who took over the five craft?

David: I guess it would be . . .

Emery: The Alliance or . . .

David: DIA military-industrial complex, what we would call MIC Secret Space Program folk.

Emery: Okay. That I can confirm 100%. They are now in control of all the tunnels and all the ships and all the bodies and all the technology, . .

David: Really?

Emery: . . . which has recently just happened.

David: Really?

Emery: Yes. And it's now very difficult to get in there, but I'm still deciding whether to go or not because it's just a matter of if they invite me again to go down there and decipher some of the ships and

craft and some of the extraterrestrials that they found, and of course, the technology.

But yes, there is a large amount of these beings and the craft down there.

David: Can you confirm anything about **Pete's** testimony regarding that the craft are so advanced that we have no idea what to do with them yet?

Emery: Yes, I can absolutely concur with that, because the group would never have called me to go down there and check this out, number one, because if they knew how to do it and they're scientists and know how to do it, they wouldn't be calling me to ask me to come on board clandestinely, which I can talk about freely. But that's exactly what happened.

David: Wow!

Emery: I mean, I haven't seen his show, by the way, so I didn't know any of this.

David: Okay. So let's talk a little bit about what we did on "Unearthing Nazca", because I didn't even know you knew anything about this. It's really amazing.

We've had X-rays taken of these bodies, and it does not in any way even possibly appear to be a hoax.

The genetic testing shows that it's over 1,500 years old or more in some cases. It appears to be genuine genetic tissue that's been preserved in diatomaceous earth.

They have three fingers and three toes instead of five, like we do. It definitely looks like this is an authentic specimen of some kind.

So I'm curious about your thoughts. Have you seen "Unearthing Nazca"?

maria ccc
F
574
CT

19-May-2017
16:21:56



L: 0.00
M: 0.00





Emery: No, I've seen just the small briefing that came out with those two mummies, and just the briefing that came out over the world and through Gaia.

David: Okay.

Emery: And that's all I read. And you know, my first question as a scientist is, who tested it? Where was it tested? How did you retrieve it? How did you get it over the border? Do you mind if I test it at multiple facilities of my choice, which you are not allowed to know?

And, you know, all these questions, because it's a very interesting story. And I'm not saying yes or no, because I don't know because I was not a part of that project.

David: Right.

Emery: So I can't judge it. Since you say these things, I mean, of course, I'm very close with you. I believe you, but as a scientist, I also have to ask many other questions and actually have to examine the bodies because I don't believe there's too many other people out there coming forward like myself that would probably go do that and give an expert opinion and write something up.

David: Sure.

Emery: I mean, I'm right now being published in Stanford University for the Atacama being coming forward with that with Dr. Garry Nolan.

So you'll see that white paper with my name on it, which kind of gives me some credit about my background.

So, you know, I can't answer that.

Just by looking at some pictures, I can't say yes or no without being part of the project and giving my own opinion of what they are and where they came from, and also the type of DNA it is.

What was the DNA percentages?

David: There apparently is a DNA test being conducted in Russia right now with some of the finest DNA testing they have. The results have not yet come in yet. It apparently takes a long time.

But we did have Peruvian scientists who did a lot of work down there.

We also have M. K. Jesse, who is a radiologist right here in Boulder, who has surveyed the X-rays and has said that this definitely appears to be a biological being. It does not appear to be anything conventional human.

Emery: Right. And the carbon dating or whatever they use to measure the dating . . .

David: Carbon dating has been confirmed, and it's all early AD – very early AD.

Emery: Interesting.

David: So would you be interested? I mean, I'm not able to ask you this on behalf . . .

Emery: Yeah, I would . . .

David: Would you be interested in doing that if you were invited?

Emery: Yeah, I would entertain that, of course. Yeah, I would be helpful in any way I can to help approve or disapprove [disprove] these beings.

David: And you told me before that apparently the Atacama humanoid that you had in “Sirius” is not the only one. Could you tell us a little more about that?

Emery: Yeah, I can. There is another being down in that location that has been discovered that is very similar to this being.

And we are now trying to work something out so we could get this being.

If we can get this being, we can get the DNA from both beings and see if they match and see if it is a new subspecies or not.

But the data that we're printing right now at Stanford is – I'm not going to spill it because I can't talk about it – is going to talk about that exact thing.

So you guys are going to have to wait for that white paper to come out in a couple of weeks, and then we'll go from there. But I'm very interested in that being, too. I want to immediately grab this being, put

it in a safe place, and be able to run multiple tests on it and see what happens and go from there.

It's a speculation right now, so we can't say anything until we actually have the DNA in our hands.

As you know, as I went over to Barcelona with Greer and Dr. Bravo to obtain the first one and bring back that DNA to Stanford for Dr. Garry Nolan to test, one of the world's leading geneticists.



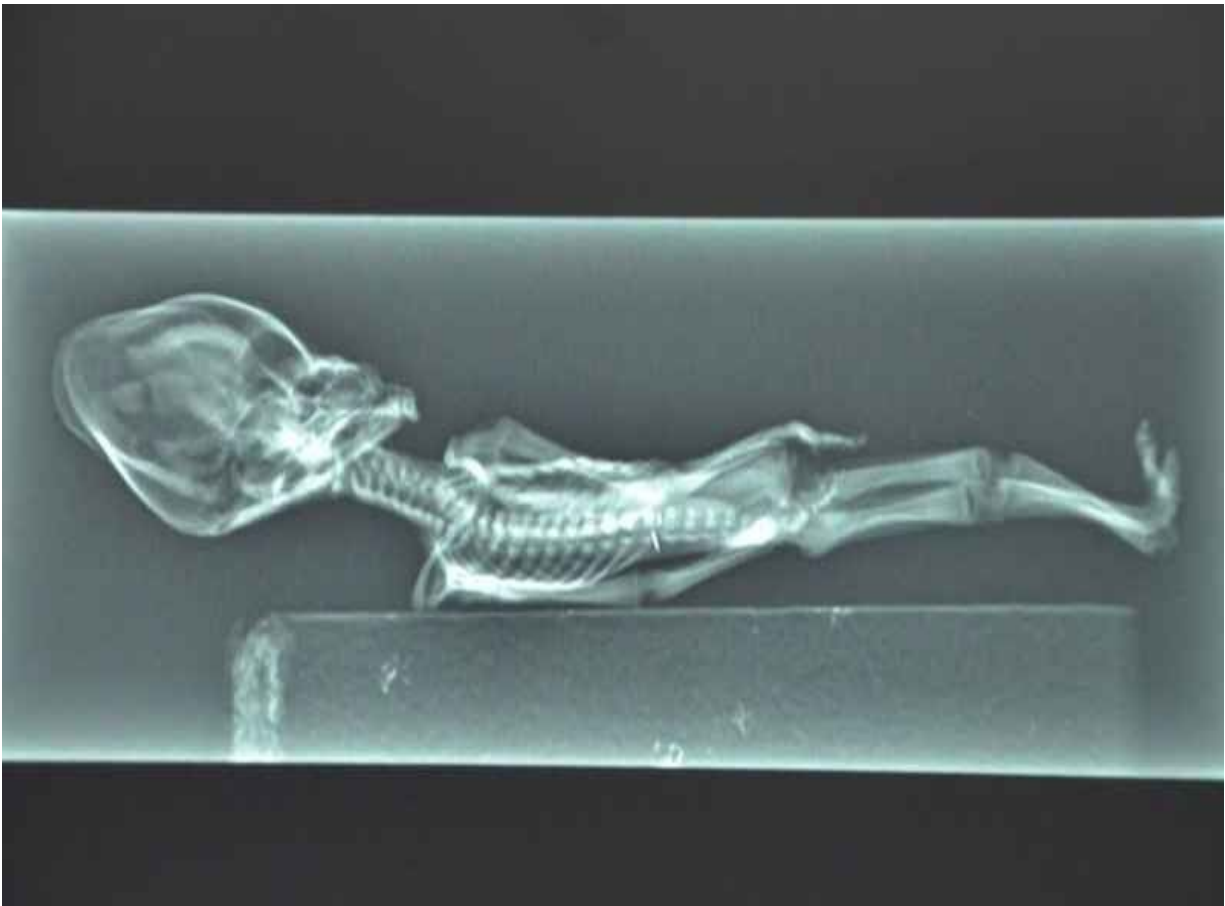



So there's a lot to do, because you have to have, I think, in the future, multiple testing sites, and larger teams involved in organizations. So it's just not one foundation doing all the work.

And it should be a joint collective thing. Most projects like this should be collective and not just one overseer of that. I think it's harder to manipulate things when there's multiple people involved instead of one overseer.

David: One of the things that you carry with you is something that hardly anyone has ever seen. You seem to always have it with you.

The only other time this was ever shown was on stage at Contact in the Desert. You handed it to me when I was doing a panel. It was a sensation for the audience.

Emery: Ah, right.

David: So could you hold up what it is that you have and tell us about this?

Emery: So this . . . After the team and I went over there to Barcelona . . . This is the Ata being from Chile, from the Atacama Desert.

And what we did was we wanted to make sure that we not only have the DNA, but let's run every possible test. Let's get CAT scans, MRIs, X-rays, as much as we can for the scientific community to look at this because the private organization that has it, who's been very generous and needs lots of help, would like to do more testing and do more things.



And I was able, by working on some other secret projects at the time . . . We can 3D render organs and things. We can also 3D render pretty much any CAT scan into any material.

So we can shoot your brain, CAT scan your brain, and I can enter it into the computer, and I can print your brain out in any material I want.

David: Wow!

Emery: Isn't that cool?

So that way, before I operate on you, I can make sure where all your blood vessels are, and I can actually do . . .

David: Oh, wow!

Emery: . . . yeah. So I can say that now because it's already out; it's been disclosed.

David: Right.

Emery: So I thought, "Hey, why don't I take a CAT scan of this being and put it into the computer and make an exact replica, duplicate, cell-by-cell," into this just polycarbonate I used, because it was already too expensive to do anything else?

David: Here, let me see it.

Emery: And what happened is: we printed it and this is what came out, this polycarbonate exact being.

David: So one of the things that I notice right away, which people probably notice, is that, like, the head is kind of sliced off.

Emery: Yeah. When we made the program, we made sure that part was open so people could see inside and see the brain lobes, and, you know, there was different things. You know, I could print just with the chest open so you can see some of the lungs and different things that were in there.

But just to have something that was durable that I wanted to last a long time, and something that you could see the volume of. Of course, the skull was the most amazing thing: three times the size of our skull.

David: Yes.

Emery: From chin to top, that'd be like . . . it's the same length as his torso from the sternal notch to the umbilicus. We call the belly button, umbilicus. So, you know, it's three times . . . the same size as that.

That would be like your head, one, two, three, three times your own size.

David: Wow!



Emery: So, very interesting.

The story on this being, if you want me to go into, is . . .

David: Yeah, sure.

Emery: . . . which I was not part of the collection site or anything like that in the early years, but I did read a briefing that matches that of where this craft has crashed. And it was shot down some time ago. I don't know the exact time.

And it was an egg-shaped craft, and there were . . . about the size of a Volkswagen van.

David: Hm! The size of the egg?

Emery: Yeah, the size of the egg. There were five occupants. And when the army got there, the military – not ours, but theirs – got there, two of them were already dead, the adults. They were 22 inches high.

And then there were three trying to get away. And they shot one, and two they lost into the jungle, or into the desert, or whatever, which the story goes they did wind up in a village.

And the villagers apparently saw these little beings, and they clubbed them and wrapped them in cloth, in red cloth, and went to . . .

David: Why would they club them?

Emery: Well, I'm going to tell you. I'll tell you why I think they did. Because after they wrapped it in red cloth, they took it to the front of the church doorsteps, and they wrote "El Diablo", and they laid it there.

David: The devil.

Emery: Yeah, the devil. So how unfortunate.

David: You know, the skull . . . This is one of the things that I always wondered about is: there's this crack in the plate. Like there's these two plates, and this part here on the left looks like it sticks up in ridges over the part on the right.

So that's not the regular physiology. This is because its head was crushed?

Emery: No, it did have that kind of a point there after we looked at that in different computer programs, but it is offset because of the smashed skull.

David: Right. Okay.

Emery: And the hole in the back of the head, so you know, was also something that was done prior to myself and the team actually doing the autopsy.

I did use that hole, though, that was made by another scientist before me many years ago, to gather the brain material, some of the brain matter, and, of course, some of the layers of the brain.

And some of the bone marrow, of course, was what we're really after. So we took some of that from the rib cage and also from the humerus of the arm of the being.



So we had a lot of samples. We had a lot of good samples. And we took those samples back.

David: Now, it is very interesting, something that I wish we could have gotten into “Sirius”.

Emery: Right.

David: I wanted to see us go into the fact that there is a case in Russia of a little being called Alyoshenka.

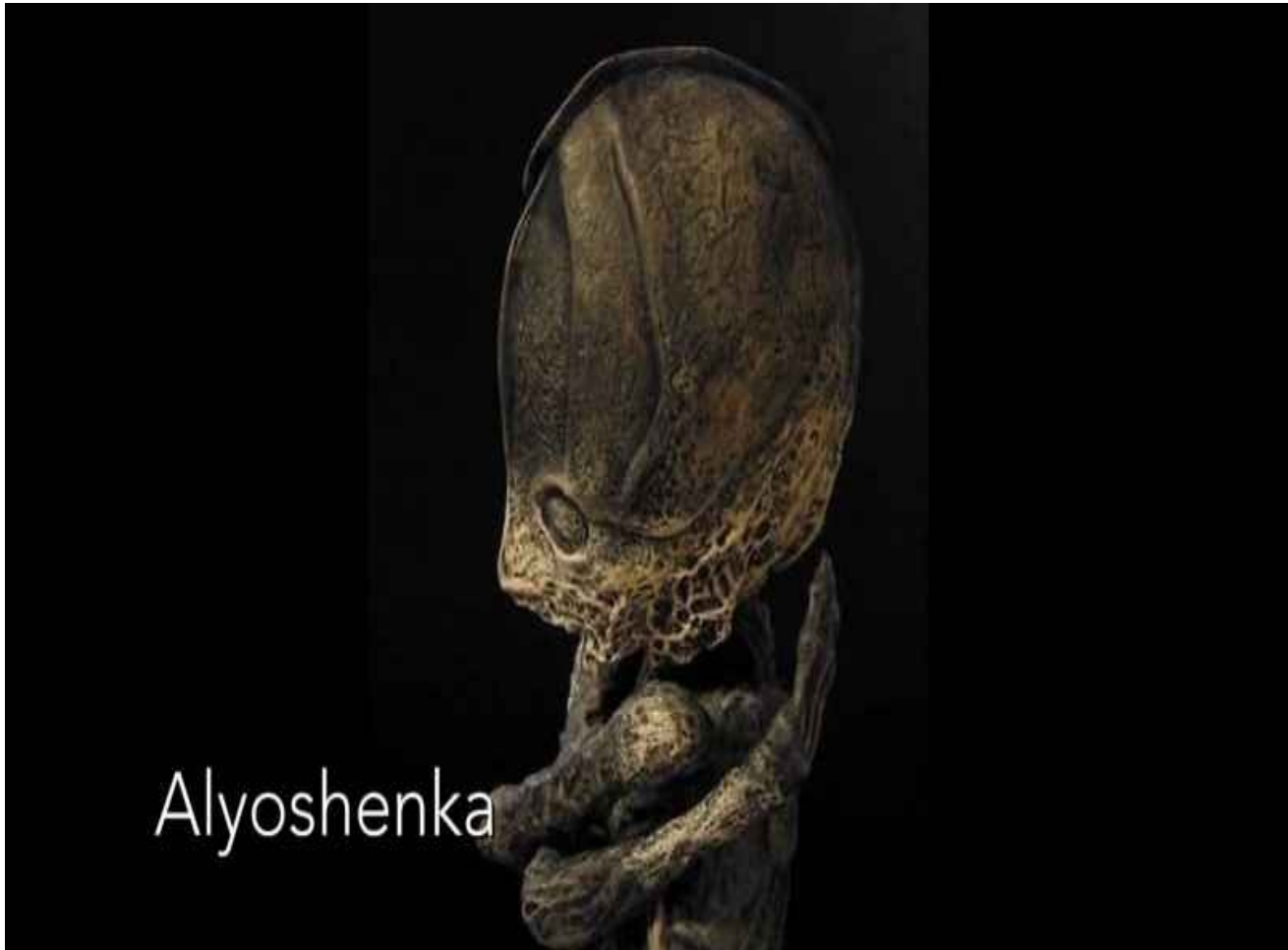

And this being does have the 22-inch height that you're saying is like the adults, but the dried body of it is basically identical. It is essentially identical to what this looks like.

And the story there was that the being somehow was found by a woman who had mental illness. And she was feeding it candy and milk for a while, but it was dying.

And she tried to bring it to the hospital in Russia, and after it was brought to the hospital, it died. When its body dried out, it dried out the same way that this Atacama being did.



And then, unfortunately, the story goes that the Japanese were going to buy it for a very large sum of money to study it, and then it mysteriously disappears.

So what do you think Alyoshenka is?

Emery: Yeah. It's hard to tell. Like I said, I don't know the story. I know a little bit about the story. I did read a little bit about that briefing.

David: Yeah.

Emery: And then like with anything, even with this being, you have to understand this is not something that I saw actually inside where I was at.

This was after I got out that I was able to handle this. And I just associated this briefing with this accident at this exact place, so to make that clear.

David: Okay.

Emery: And don't forget, things can be made inside for disinformation campaigns as well. And beings can be grown and these crashes can be made to disinform scientists around the world that are not part of the projects.

And some that leave the projects, they want them disinformed.

So you have to be very delicate about talking about DNAs and beings, and where they come from and the stories behind them, because there's very few people out there that actually know from start to finish: all right, this went to this to this to this.

You know, I'm being a private investigator saying, "Well, this is what I read. This is what happened. Then later on we finally got it. And then we did this, and it matches everything. There's another one; matches the same exact report." You know, all these different things.

So that I would not . . . I would just say I think it's a similar . . . I think it's part of the same phenotype of species.

Without looking at the DNA and actually matching the two, which would be the most amazing thing . . .

The fact that it went missing, 100% - obviously, red flag. Red flag, red flag.

Any time anything goes missing or someone gets hurt or killed, you know, it's a red flag.

David: Do you think there's any relationship between this story of the church with the being in paper labeled "El Diablo" and the corpse that ended up in the movie "Sirius", or are those two separate things?

Emery: You're talking about the Ata? The Ata?

David: Yeah.

Emery: No, that's the Ata.

David: Oh, that is?

Emery: That is the Ata.

David: So did the church hold onto it all that time?

Emery: Yes. The church held onto it.

David: Really?

Emery: The priest held onto it many, many years. He knew it was very, very important. And then he made a deal with someone.

I know the U.S. government already had samples of this somehow. So in the exchange somewhere, there was this civilian person, the priest, who had access to it. And then a private organization went down there and purchased the being from him, and now it's in an underground facility near Barcelona being studied.

And many new papers are coming out. I know they're printing so much stuff.

My own opinion, I think they got a little bit infiltrated and maybe paid off because of some of the things that are being said now over from their people in Europe.

But, you know, like I said, we don't know. It's all speculation, because anything can be made to be disinformed.

David: “Sirius” itself kind of ends on a down, because we're talking to Theodore Lockman; we're talking to Garry Nolan. The whole movie establishes that this is a credible non-human – normal human, at least – thing.

And then at the end, it kind of seems like the film says, “Oh, well, it's not really that big of a deal”. It's very strange.

Emery: That's very strange, yeah. Why is that? The biggest story in the world and no one wants to hear about it.

So, yeah, I would say, “Hm”. That's all I can say about that.

David: Right. So another thing that I find fascinating is “Ripley's Believe It or Not” in, I don't know, 1940s, 1950s, somewhere thereabouts, had this thing called “AttaBoy”.



And it's just like the Atacama humanoid – same size.

The only real difference is that the head is a little more bulbous in this way [round] . . .

Emery: I saw that, yeah.

David: . . . as opposed to the way the other one looks.

Emery: Yeah, I saw that one.

David: It's so similar in many other ways. Do you think that's from the same species or a similar species?



Emery: No, I don't believe so. No. No. Yeah, there's too many differences.

I did look at that at one time closely. So I don't believe it's from the same lineage or phenotype at all.

David: But do you think it might possibly be extraterrestrial also in its own way?

Emery: Without actually making a . . . bringing the proper test, I couldn't speculate.

David: Right.

Emery: It wouldn't be fair.

David: So another thing was these edifices that the people on Easter Island wore on a necklace.



Emery: Right, yeah.



David: And when you look at the necklace, when you look at the body of this thing, it looks exactly like what you autopsied in “Sirius”.



The only difference is that the face is kind of a stylized human face. It's got these large, round eyes, large kind of nose and mouth.



So it is kind of an exaggerated human face with large eyes.

Emery: Uh-huh. With every passing day, Antarctica is garnering more attention from mainstream and alternative news sources, alike. **Emery** Smith urges, that as the ice melts, the secrets at the south pole will no longer be contained. What is being disclosed now, in Egypt as well as Antarctica is just the tip of the iceberg as ground penetrating radar is discovering large voids. Although we are being told of the great voids, what is in those voids is being withheld. Now, new reports of tunnels in South America, as well as strange beings, such as the Nazca Mummies and Atacama Humanoids, found in these locations are coming to light. **Emery** Smith fills in the gaps of withheld information with his insider's view on what is really taking place under the Antarctic ice. This interview with [David Wilcock](#) was originally webcast January 30, 2018.

David: That part looks wrong. But the body is absolutely dead-on.

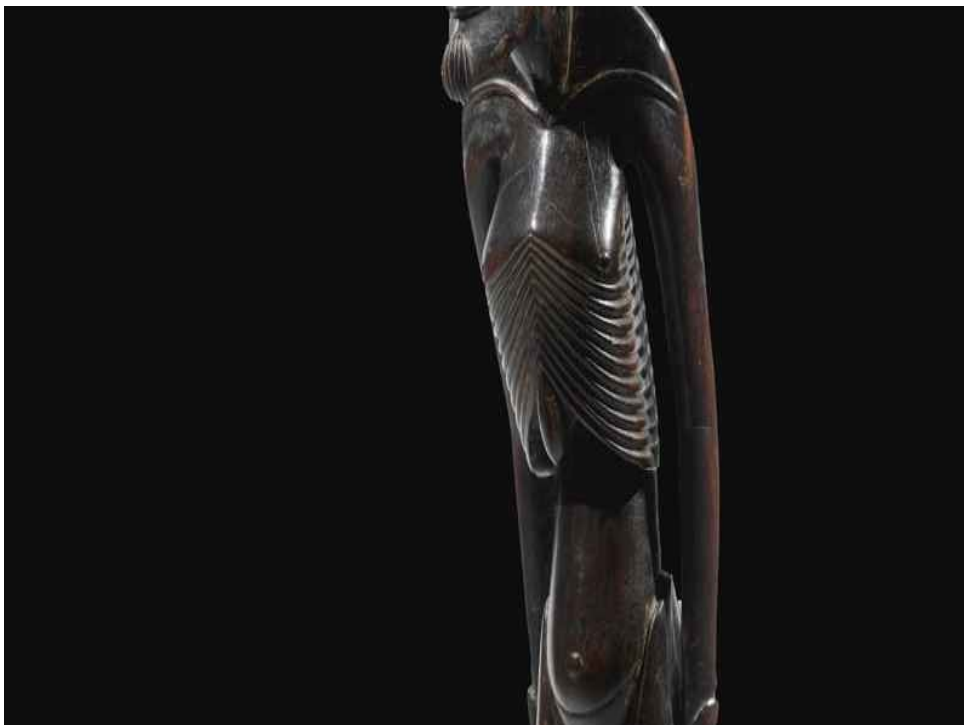

And those Easter Island people are saying that these were the givers of wisdom and knowledge.

Emery: Right. I think there's a connection.

David: What do you think is going on?

Emery: I do think there is a connection with that. Like I said, I don't know enough about their history. I just know, from learning from you about that story and seeing some of these pictures a while back, that there is correlation, for the body, that is.

And whether the bodies are replicas or they're the actual bodies that were mummified, you know, swelling happens during mummification sometimes, depending on where it's buried and what it's buried in.

And things can change and misform different body parts, especially with the skeleton, into different . . .

David: Right.

Emery: Just like fossils, you know, if they're in certain minerals, when they form over time, they'll take on a different color and shape.

So it's a very interesting thing when you look at mummies and how they're buried, where they're buried, the temperature, the humidity, and then all these other factors that fall into place. And the same thing happens with these beings.

So I can see why you're asking these questions, because they are similar in many ways, but they're also . . . There's differences. And without actually having all three of them right there, for me to say.

But I do agree with you that the bodies are very similar.

David: All right. Well, I want to thank you. This has been very fascinating, and we will have more in store.

Emery: Excellent.

David: So thanks for being here.

Emery: Thanks for having me. Appreciate it.

David: And thank you for watching. This is "[Cosmic Disclosure](#)". I'm your host, **David Wilcock**, here with our special guest, **Emery** Smith.

Cosmic Disclosure: Nazca Tunnels and Super-Suit Technology

Season 9, Episode 11

David Wilcock: All right. Welcome back to “[Cosmic Disclosure](#)”. I'm your host, **David Wilcock**. And we are here, once again, with our special guest insider, **Emery** Smith.

And **Emery**, again, I want to thank you so much for finally stepping forward to do this.

Emery Smith: Well, thank you, Dave. It's been a long time, as you know, around 10 years for me to come out and talk about it.

And I think it's time for the people to know to add to what you have already been teaching.

But there's some gaps there, and I want to help you fill those if you have any questions with them.

David: We had talked about this briefing that I got from **Pete** Peterson that was very recent in this idea that he was following up on what he gave us on a previous episode of “[Cosmic Disclosure](#)”.

Emery: Okay.

David: We were talking about the idea that there are these vast carved tunnels underground – smooth, almost glass-like interior – like it's . . .

Emery: Obsidian. Yeah.

David: Right.

Emery: Melted rock. Yeah.

David: So you know about this?

Emery: Yes, I know.

David: And he said that, in some cases, they follow the Nazca Lines, and that there are these chambers off the sides that look like people were living there, but it appears that whoever was there just took all

the stuff out when they left.

So could you just speak to that for a second – that part of it? The idea that somebody might have cleared everything out, and it might not have been us, per se, but maybe it was the beings themselves.

What do we know about why it was so abandoned looking?

Emery: Well, there's actually a lot of the craft down there, and they're connected to many other tunnels.

I don't know what he was debriefed on, but what I was debriefed on is, you know, there's over, you know, 200 to 300 craft down there, and many beings that are kind of petrified into the walls.

And it is like a lava tube-type of cave system, where it was intentionally melted, it looks like, and frozen in . . . like frozen . . .

David: Right.

Emery: . . . in some moment and some sort of suspended animation, I would say.

David: Well, that is interesting that you said 200 to 300 craft, because this briefing from **Pete**, he was speculating that there might be as many as possibly 500 down there.

Emery: Oh.

David: So that's a very similar number.

Emery: Oh, well, just in Mexico alone, in that area is about that, but those go way down south too.

David: Wow!

Emery: So this is a big collective group of scientists, which have now just had to turn it over to the U.S. government.

David: So another one of the things that he said in this briefing that I've never shared with anyone, and I'm just going to drop it on camera right now, he said that the latest intel that he's aware of is that there are evidence of five different epochs on Earth of extraterrestrial colonies that were fairly large and fairly considerable when they happened - that they're almost all underground.

And he said that of these five eras, some of them go back millions of years, and that they are very different: the type of technology, the type of society, the way that everything looks. It's all very different.

So I'm wondering if you ever heard about there being like five major, if you will, ages of extraterrestrial colonization of Earth?

Emery: I've heard up to five. I've kind of known of three, because of artifacts and beings, but that's just secondhand.

I mean, firsthand that I've seen the stuff and read the briefings, and I've seen some of the technology and some of the bodies, of course.

But, yeah, that is correct. There must have been at least five different civilizations that, you know . . . We're talking million year gaps though.

David: Right.

Emery: We're talking, you know, different times, you know. And I think maybe that might be correlated with the stuff in Egypt and Antarctica, and, you know, ancient Lemuria and Atlantis.

It's all kind of tied into different time zones, because the symbols and the thing they're finding, and all the equipment and technology, is completely different, like you said.

So there are a lot of scientists out there they are hiring now to put in like . . . to crack this code, like, what does this mean?

And some of the stuff they can't operate, of course, because they don't understand consciousness is just a technology, number one.

Number two, it's such a higher science that we're not even . . . we've never even learned it, and it's so beyond us that we wouldn't be able to understand it if I was an ET talking to you trying to explain it,

because it would be beyond your, you know . . . It would be beyond your brain to assimilate that, knowing what you know now.

David: I was particularly fascinated in the previous episode when you talked about the idea that similar ruins as Antarctica were found in a cave in Costa Rica. And I want to throw something at you and see what you say.

One of the insiders told me about a complex that was found underground in Ecuador, and that Neil Armstrong and certain other NASA astronauts were given the ability to go in there.

It's VERY advanced. It's VERY amazing, and it's similar to Antarctica.

And I've never found another insider who had a corollary point of data for that particular thing.

I've tried **Pete**. I've tried **Corey Goode**. They didn't know about Ecuador.

Emery: I did tell you it was NEAR Costa Rica on the last episode.

David: Oh! Right.

Emery: So correct. Yes, I've been there.

David: You've been to the one in Ecuador?

Emery: Yes.

David: Really?

Emery: Yes.

David: Well, from what I heard, it's absolutely amazing.

Emery: Yes, it seems to have already started its own flora and fauna growing in this . . . There's a craft that crashed there a very long time ago, and it still had some sort of energy system on.

It must have carried extra bacteria or something because deep down in there it's actually kind of a very bio-luminescent type feeling, and its atmosphere is a little different than the atmosphere on top.

And it's NOT very deep under the ground, so you know.

David: Hm!

Emery: But I can tell you that the plant life down there is unlike anything I've ever seen on Earth, . . .

David: Wow!

Emery: . . . so that was really astounding. Of course, some of the little insects and other things that were running around were also very different. And this is . . .

David: Wow!

Emery: This place is highly guarded and has a really good security system, but I think it's going to be brought to the public because of other organizational satellites are now picking up on Inner Earth things just by accident. So it's going to be hard for them to hide this one.

So he is correct about this . . . Did he call it a cave or . . . ?

David: He just said it was an underground complex.

Emery: Right. It's an underground complex. But it really was a craft that we think may have crashed there or stayed there at one point, and then they started building around it.

And then, since it was so close to the surface of the Earth, the water . . . and it opened up and runoff went in there and some of the flora and fauna has mixed with this stuff, whatever they brought, or it could be the energy from this craft in there that's changing all this stuff.

And I can't get into more detail than just that.

David: Okay. It's been driving me crazy that he used words like "very amazing", but then wouldn't give me any actual detail of what we might see.

So could you give us a little bit about what we might see if, at some point, we get to go in there?

Emery: Yeah, I can, I just hate to use movies as a retrospect.

David: But movies are programmed with information to discredit whistleblowers.

Emery: It would make “Avatar” land look like a small school playground.

David: Wow!

Emery: Everything in there had fluid running through it. The stems of the branches look like it, you know, had fluid running through everything.

David: Wow!

Emery: There was light, you know, like light from everything – all different kinds of shades of light. Light I've never seen before.

Not just talking about the colors of the rainbow, but so many amazing colors.

And the plants are the most amazing things, and they're like conscious, not like our . . . Of course, all plants are conscious, but they are different in that way.

Everything down from the leaves to the soil was sponge. It was soil. The soil was all sponge, like you're walking on a one-inch foam mattress, I could put it, you know, how you feel that little gushy?

David: Uh-huh.

Emery: And everything is really humid.

And there were little creatures, like little animals, like the size of mice there that were like naked moles, like naked little shrews, running around that were definitely different. They actually had color that was emanating from them, and I don't know if it was a reflection of light from the light that was in there or if they were emanating light.

I was not there to, you know, talk about that specific thing. I was there on some . . . to do something else. But it was the most fascinating . . . one of the most fascinating things I've ever seen here on Earth.

And I do believe there's a lot of other biospheres that are formed. This one just got cracked open somehow and mixed with a lot of our stuff, and that's what they were concerned with. Would it leave

this area? And it can't.

The plants they took out of there, and the animals they took out of there, could not survive on the surface of our Earth.

David: Wow!

Emery: So it is its own type of biosphere. And maybe there is an electromagnetic field that's protecting, you know, the opening in that area from anything, you know, going out or, you know, coming in.

David: Part of what he meant by “very amazing” . . . And I'm really glad to hear these details. It's making a lot of sense now.

And, I guess, I'll just say this first that, apparently, this was one of the ways that Neil Armstrong and other astronauts were bribed to stay quiet.

And from what you're describing, it sounds like it is so incredible that you would want to stay quiet just so you could go there more than once maybe. Or . . .

Emery: Yeah, there was an exchange of favors. There's no money ever exchanged in these programs. It's all favors.

David: Hm.

Emery: And if you don't comply and take the favor, then there's usually a big problem. Favors such as bringing also the astronauts to Antarctica, as you know.

David: Right. Yes.

Emery: So . . . And all of these other places that are very special in the planet that we haven't even elaborated on yet, as this one is.

So there's multiple places like this, actually. They're in the Earth and around the Earth. It's just that this one happened to be cracked open like an egg and beautiful things come out.

David: As for technology, when he mentioned “very amazing”, he did imply to some degree that there were things that looked like a really cool spaceship that you would see when you went in there.

So could you elaborate a little on that part as well? Like what's the interplay between technology spaceship-looking stuff and stuff that looks like the gardens in “Avatar”?

Emery: Well, the craft there are light, and so it's not something you'd kick the tires on. Ha, ha. And the light is palpable. And it is round and oval, and it is very long and thin, but it's large. It's fairly large, what I saw, and I didn't get to go all the way in, by the way.

I was only in the first 300 yards, so, and that was enough for me to be completely . . . My mouth dropped open.

David: Wow!

Emery: And so this light craft is palpable. So think of light not being blinded like the lights we have right now on us, but a light that glows that you can see it and focus on it without being blinded.

And you can enter it from any place you want on the craft . . .

David: Wow!

Emery: . . . once . . . when you walk up to it and touch it. It's a biometric-type thing.

David: I mean, that's very interesting, **Emery**, because when **Pete** was on “Cosmic” talking about this craft in Antarctica, he described that it had a sort of diffuse glow.

Emery: That's right.

David: That everywhere was just light, and no matter where you went, it seemed like the light was always there.

And he also talked about how one of the children that was brought in for these programs figured out that you could speak to the craft, and you could talk to it, and it would mold itself based on what you wanted it to do, and what you told it to do.

It was able to figure out language or thought, or something.

Emery: Absolutely. Yes, definitely. That's, you know, . . . The whole consciousness is just a technology that we call it here today on Earth.

And the craft are all alive, and you don't have to . . . To fly a craft, you just have to kind of say, "Go", and where you want to go. It's that simple. And . . . Or think where you want to go, and it'll get you there safely.

And wherever you look in the craft, you can see completely outside the craft. So no matter where you look, it opens up, and you can see very clearly exactly where you're looking to a very wide angle, . . .

David: Wow!

Emery: . . . including up and down.

David: And can you also get binocular vision, like telescoping vision?

Emery: No. I have not experienced that.

David: Well, one of the things that **Pete** talked about was that our more advanced fighter jets, the classified ones, have this technology that goes through these nubs in your shoulder blade.

If you feel your shoulder blade, there's a little dimple in there, and he said there's a lot of nerves that cross in. And he was part of a team that figured out how to pump signals in through those points that they called ports, and you can actually allow people who are blind to see.

And that on the jets, the jets don't need windows, but you can look out from your mind's eye, and it's the same as vision, except that it also has binocular telescoping function.

Emery: You mean you don't need heads-up display.

David: Right.

Emery: Not . . . You need your . . .

David: It's in your head.

Emery: You need your, of course, protection.

David: Right.

Emery: Right. Yes, that's definitely true. It's been out for a while. It's kind of old technology.

David: Ha, ha. Old technology?

Emery: Ha, ha. I'm sorry. And that's . . . They even make toys now, where you hook up something to your finger and think, and the ball floats in the air with a fan or something.

David: Right.

Emery: So all that is real, and that's kind of old technology compared to what we have now – especially with the new suit program, and things like that, is all incorporated into, like you said, into the helmet, where you can think, like you just said, with some of these helmets. And you can zoom in, zoom out.

You see in different wavelengths and light, and, you know, just like you said. So [i] very familiar with that. I can definitely concur and confirm what he said was true.

David: Well, I guess since we're on a technology theme here, let's talk about the exosuit, or smart suit, or whatever you want to call it.

So could you tell us . . . Now, you gave me some very fascinating information about this suit before.

Emery: Oh my gosh, so much fun, the suit. Yeah.

David: And you've actually had the pleasure of using one.

Emery: Yeah. Yeah.

David: So tell us about these smart suits.

Emery: Wow! That's a big one, because that's like a whole series. Would you like me to start on just the amazing technology that's embedded in it, such as . . .

David: Well, what is it, first of all?

Emery: Well, number one, it was designed to be able to go anywhere, and . . .

David: Is it a suit that you wear? Like what people . . . We've got to give people a visual first.

Emery: Oh, okay. Well, the way . . .

David: What would you see on somebody who is wearing one?

Emery: If you would see this suit, what it would look like, if someone had, like a scuba suit on.

David: Okay.

Emery: A very small amount of neoprene, but it's not neoprene at all, but it would . . . It fits that tight, and it's very, very thin.

And the suit has the ability to absorb all the shock on your body, if you were to jump, you know, 40 feet off a cliff onto the ground. So all the weight is distributed into the whole suit, so your body will feel nothing at all.

David: Wow!

Emery: It also is bulletproof; it's shockproof. It's electromagnetic proof, to an extent.

It has the capabilities, and the helmet are just fascinating. It is all mind/thought-controlled, because it's actually connected to you, like you said, with these little things in your back, but not . . .

David: What about things like heat and cold?

Emery: Yeah, that's the best thing about it is: it will keep any temperature that, you know, you want. It actually measures your body at all times, and knows how much sweat you're sweating. It knows, you know, how much air you're breathing, your body temperature, your blood pressure, everything.

It also can tighten to absorb impact and release, so you can actually be so comfortable wherever you're at. So you wouldn't even feel it. You'll feel like you're naked.

But in a time where you're about to move, it all tightens up and activates, you know, in nanoseconds.

It was made as a super soldier suit to replace the old, you know, dilithium "Predator" suits that just were, basically, for the camouflage, but you had to wear armor underneath those.

So now, this one has different . . . because I think it has different types of composites in it and . . .

David: All right. Well, “dilithium predator suit”. So please explain what is a . . . The movie “Predator”, of course, . . .

Emery: Oh, that's just . . .

David: The being in “Predator” is like sometimes invisible.

Emery: Yeah.

David: But it has this thing on its arm that you can . . .

Emery: Yeah, it's the pop culture term, you know. I'll never use . . . I don't use the real terms for these devices.

David: Okay.

Emery: But you know, this type of suit, basically, are small round, like pyramids, but they're round. They're faceted.

And at the bottom of the pyramid is a mirror. And these are very, very small – smaller than . . . They're about, I think, 0.3 of a millimeter of a . . .

David: Wow!

Emery: Yeah, 0.03 or 0.3. So there's thousands of them per cubic centimeter.

David: Wow!

Emery: And what happens is, when light hits it, it reflects the light that's around you, you know, that's in front of you. And it also . . . With the old suits, it would reflect basically what was behind you, because you wanted to stand up against something, and you want to see the chair. You don't want to see me.

But it wasn't very effective, but it's really good, of course, at night and it's good during the day if you're in some jungle warfare.

But it's not as good as the one in the movie, of course, . . .

David: Right.

Emery: . . . but it was darn good, and it saved a lot of people's lives. So that's what that is.

The upgrade from that is: let's get a suit that's better than Iron Man, but gives you mobility, so you don't ever have to take it off. You could wear it for seven days.

David: It cleans you?

Emery: Yes.

David: Wow!

Emery: So that was what they're doing . . . And gives you nutrients, at the same time.

David: You don't need to eat and drink?

Emery: You don't need to eat or drink because it goes through your skin, because they have now developed a way to have nutrients and water absorbed through the skin.

David: Do you have to kind of get past an initial hunger feeling to . . .

Emery: Well, everyone still, you know, eats and drinks, and stuff.

David: Oh, okay.

Emery: It's not like, you know . . . It's just for if you HAD to.

David: Okay.

Emery: You know, you wouldn't have to.

David: Right.

Emery: But, you know, the suit does have to be maintained, you know, like a jet. It's not like you can just wear it for a year.

And it's charged with a very special type of water that's charged, and that's how they do it. That's how it actually operates through this charged plasma.

David: Is there any little box or bump on it that's like . . .

Emery: Nothing. No, it's flawless, seamless.

David: Wow!

Emery: It does have like a Ziploc feature, like a suit would, when you get into it.

All suits are made specifically for the operator. It has to be, because it won't work correctly. You could actually . . . If you were to jump in my suit and then try to go do something, you could actually hurt yourself.

David: That makes sense.

Emery: So what they're trying to do now is make an all-in-one that contours. Like it has its own AI to know, "Oh, so anyone can use these suits." So in the future, they'll probably have that.

And then there's a problem with the helmets that they're having with it, but I'm sure it's fixed by now.

David: Before we get to that, what could you tell us about things like, for example, running and jumping if you had the suit on? What would be different about that?

Emery: Well, you can run up to 38 miles an hour.

David: Wow!

Emery: And it won't let you fall. It's got a special system in it that . . . You have to understand the suit has billions of these lines, these like, let's say, like dental floss lines in it. So each thing can tighten anywhere.

So if you did . . . You know, it absorbs every bullet that comes to you, you know. I mean, you're not bulletproof, but for the most part, it'll stop a 223, no problem.

David: Wow!

Emery: So what happens is it knows if you're getting wobbly and about to fall, and it'll put pressure on that, and that whole side of the suit will tighten to realign you so you can keep going.

David: Wow!

Emery: Because you can . . . It is made to actually run through any terrain, like very rocky terrain, and also carry a lot of weight with you.

David: Wow!

Emery: Yeah. So you could actually jump off a cliff, do a back flip – even though you're not a gymnast – and you will land on your feet like a cat.

David: Wow!

Emery: It will not allow you to land on your head or hurt yourself. And the suit will take over and, you know, curl you into a ball and make sure you're going to land on your feet. It's very interesting.

It also has little types of things that can project out. The suit can actually project out little fins and things on it for swimming, and also for when you . . . if you did mess up and you are actually jumping too high to change the way you're falling, in case you were unconscious, let's say.

David: So what about jumping in particular? Let's talk about jumping.

Emery: Jumping is amazing. I mean, you could jump, I think, up to around 50 feet . . .

David: Wow!

Emery: . . . 50, 55 feet from the ground with no pack, with no weight.

Weight is . . . If you have any little weight on you, it calibrates it and that does affect everything for the suit.

And the suit self-calibrates. It's reverse-engineered extraterrestrial technology that they use. It's definitely not something that we just thought of brilliantly and made.

So it is something that is using a lot of this other technology in it. It was developed only for like really,

really upper-class, special-ops projects people, which has nothing to do with the government. I'm talking about a very higher level of, you know, things.

So now we have the opportunity to bring this to the world, without all the special features, but the protective features that we would like to give it to, of course, you know, start off with like the police officers and the firemen, and stuff, because it's amazing.

It can protect you from heat, of course, cold.

David: All right. Let's be a little more specific though.

Emery: Right.

David: When you say “we . . .

Emery: Right.

David: . . . could you be more specific about who is “we”? And how would this suit be able to get out to the public?

Emery: The people who have invented this suit, I'll just say, want to see it put to good use. And there's other, you know, types of these suits, of course, that can do other things that are, you know, war-like type things.

So instead of doing, you know, going that level . . . because these are prototypes, you have to understand. This is not available yet for any . . . you know, too many. So these are all prototypes.

So they're out there, you know, thinking, you know, what are they going to do with it?

The reason I got involved with it was because they needed a substance that I had, and it was: “If you could get us the substance for the suit, to make it levitate, then we can make a deal with you with the suit.

“We can give you your own suit, but you know, we have to, of course, keep the suit, but you can have it, you know, whenever you want. Of course, you can't, you know, go running around cities with it or

show it off, but, you know, you can go to undisclosed huge places out in the middle of nowhere in the United States and have, you know, do your own testing on it.”

And that's what I wanted to do, because I knew the materials that it was made with – especially the helmet I was working with, which is completely separate from the suit, but it was going to be made for the suit.

You know, it was completely materials I knew were extraterrestrial origin that they just reverse-engineered.

David: You kind of quickly said something about it levitating.

Emery: Yes.

David: What does that mean exactly? How would it levitate?

Emery: Well, levitation on this suit would have to do with white gold.

David: Hm.

Emery: They needed the pure white gold from the ancient times.

David: Really?

Emery: Yes.

David: But what kind of levitation? Could you be more specific?

Emery: Well, the suit is consciousness assisted, so by mixing these properties of the suit with this special white gold, you'll be able to levitate. Yeah, you can actually levitate.

David: To how much of a degree?

Emery: As much as you want.

David: Really?

Emery: Yes.

David: Wow!

Emery: And if the suit was built correctly enough, you could go to space with it.

David: Well, it is strange, because occasionally, here and there, you get these stories sometimes – there was one in Australia recently of what appears to be a man levitating in the air.



Emery: Uh-huh.

David: You know, a human figure . . .

Emery: Oh, right.

David: . . . just levitating in the air. How many of these suits are out there for people to test?

Emery: There's only two . . . I only know of two suits.

David: Really?

Emery: Yeah. I only know of two suits of this . . . from this manufacturer. Yes.

I'm sure there's MANY other suits. I mean, I've seen many Iron Man-type things out there, you know, like real . . . that kind of thing, but not to . . . not like this.

David: Right.

Emery: Because this is beyond, you know, nuts and bolts.

David: Sure. And I want to point out that **Corey Goode**, when I brought this up to him, he said that they had this in his Secret Space Program, and he used them.

And he did say that there was a momentary type of anti-gravity, that if you fell for like the last two or three feet before you hit the ground, it had enough gas to kind of levitate you before you hit the ground, so you make a smoother landing, but it's only a short term, brief levitational capability.

Emery: Yeah, the suit for jumping and for landing, with the suits that I'm aware with, had none of that. It had . . . was using electromagnetic fields to do that.

David: Oh, really?

Emery: Yes.

David: And also, we've seen movies like “The Edge of Tomorrow”, the Tom Cruise film, “Live, Die, Repeat” . . .

. . . where he . . . the soldiers have these big bulk metallic chassis, . . .

Emery: Oh, right.

David: . . . and they can like move parked cars with them, and things like this.

Emery: Yes. That's very old school technology. It's used in every secret project. They're very common in underground bases.

David: Really?



Emery: Exoskeletons, like you saw in the movies – even in the “Alien” movies with Sigourney Weaver and stuff, those big ones.



David: Right.

Emery: They're much more smaller now. They contour to your body easier. They're very adjustable, and they're not as bulky.

And you can, you know, lift 10 times your own weight. You can lift . . . You're a human forklift is what it is.

David: Wow!

Emery: But you're not . . . It's not made for jumping, or acrobats, or, you know, running at high speeds, the ones that I'm aware of.

David: What could it do for you if you get a laceration or a broken bone, or something like that? Does it have any countermeasures for that?

Emery: Absolutely. The suit itself will contract on that to stop the bleeding and add an coagulating factor to that, built into the suit.

David: Wow!

Emery: Not only does it give you vitamins, minerals, electrolytes, nutrients, and other special proteins and amino acids, so you can communicate with the suit better, and the suit communicates with you, but it also can set your leg.

So leg breaks, that becomes now one solid piece.

David: Wow!

Emery: Yes. It's amazing.

David: What about the pain? Does it have . . .

Emery: Yeah, it can give pain if you direct it to give pain, or if there's also operator induced. You know, like if you have the satellite - of course, [it] comes with a satellite – and the satellite will know.

And someone usually is communicating with you from somewhere with it. You're never, you know, just running around, and this kind of thing.

And this is completely the prototype, by the way.

David: So what would happen if you're feeling a great deal of fear, anxiety? Would the suit know that you're afraid? Would it have any way to help you with that?

Emery: Yes, it measures pheromones and chemicals in your body, constantly. So it's a constant laboratory.

So it knows if your adrenaline goes up. It knows when your heart rate goes up. It knows . . . You know, it will analyze things.

And plus, don't forget, it's usually connected to also a team that's watching you, and they will take precautionary methods and may, you know, administer epinephrine, you know, or morphine, or you know, whatever it is you need to be extracted out of where you're at, if you were really that hurt.

David: Does it have any aromatherapy capability?

Emery: Not that I'm aware of. I don't remember seeing anything like that.

David: Okay.

Emery: I was not debriefed on that.

David: Well, it is interesting, because **Corey's** version of the suit is almost exactly the same as what you're saying.

One of the only things I remember HE said was that if you were upset, at certain times, it would give you a smell like lavender, or whatever smell you like, it can generate that for you.

Emery: Yeah, what it does, with this suit, is it doesn't use pharmaceuticals. It uses . . . Your body has its own chemicals to deal with stress.

And what it does is why it's so important that each suit is made for you is because once we do get your blood test, we actually measure all those chemicals in there that, you know, actually initiate fight or flight movements.

So it could give you really quick some dopamine and serotonin, which is cool, though it's an autologous dopamine and serotonin.

And autologous means it comes from your own body. It's just concentrated.

So it has the ability to help you heal and cure you, and add your own chemicals that you would need to do that, so you wouldn't have to, you know, take anything else. Like it alleviates all that pharmaceutical-type stuff.

David: If this were to be distributed to the public, how would we prevent somebody from – essentially like a terrorist – to becoming an indestructible super villain by having a suit like . . .

I mean, I guess, other people with the suit could defeat somebody like that.

Emery: Yes, it's not . . .

David: How would you stop that from being misused?

Emery: Yeah. Well, that . . . You know, that's the whole thing. So I think that the slow release would be to like the police officers.

And plus, it would be downgraded to just do for what they needed. Bulletproof. They wouldn't get to jump. They wouldn't get to run as fast. They wouldn't have as many fibers in it. It wouldn't have all the nutrients and all that stuff.

It would probably have more stuff to protect the person – more of just a protective suit, but nothing else to be superhero-type thing, you know.

And that's kind of how they want to launch that for civilians. And then make a civilian one that helps with people that are sick or helps people that have dangerous jobs even . . .

David: Like a lifeguard.

Emery: Like a lifeguard, or welders, or, you know, people that deal in dangerous positions where they get burned.

David: Firemen.

Emery: Yeah, firemen, like we just talked about. And then, you know, that would trickle down to the future suits of just everyone being able to have one, you know, that it just kind of keeps you healthy and keeps you strong, and, you know, that kind of thing.

David: Is the production of something like this technology kind of similar to how our chips in our smartphones keep getting better and better, and, as they get better, then they're mass produced? And now it's not expensive anymore because we're making them.

Could the suits ultimately get to be consumer level price, do you think?

Emery: Oh, absolutely, but it wouldn't have all, you know . . . It would be limited with features. You know, it's all about that.

So, yeah, you wouldn't be able to get the X-phone 20, but you can get the X-phone 10 today.

David: Ha, ha, ha.

Emery: Inside joke. But yes, I mean, that's how it works.

I don't think . . . By that time, I do believe that we won't need to do that. I think these things will be able to be handed out to everyone. I think that we're not going to . . . We're going to be moving away from this consumer thing pretty soon – in the future, I mean, within the next 20 years.

David: I wanted to not leave this unturned. You said there was a problem with the helmet. Could you describe what the problem is? Why wouldn't the helmet be good?

Emery: The helmet is amazing. The problem with the helmet is pressurization and communicating with the suit, since it was a different developer.

David: Oh.

Emery: It's just . . . The helmet works flawlessly. It's just it's not connecting to the suit correctly, because the suit is so perfectly sculpted to the body that the helmet is actually not, okay? So it's a little bit bulkier. Small – much smaller than a motorcycle helmet. Okay? And that's the problem, right now, they're having with that. But it's probably fixed by now. That was in . . . last summer. I mean, not last summer. That was the year before last.

David: So are we correct in saying that you have been given an opportunity to become a distributor for this as it rolls out to the public?

Emery: Yeah, more like a connector, I like to consider myself. I'm not so much on the business aspects of that stuff as I have so many other things going on.

But I would like to connect that, so it's, you know, put to good use to protect the people that are protecting us right now, you know, that are out there, such as the police officers, and the firemen, and the paramedics, and, you know, all of these other people in the civilian world, because, you know, it's getting kind of crazy out there, and they need some help.

They need to be a little bit more ahead of the game with these asymmetrical threats. And, you know, these things can, along with the helmets also, . . . There's no way something can sneak up on you, so . . .

David: I'm curious about things like international law and the United Nations, and how they might feel if a particular military gained access to this technology, and they would have such a disproportionate advantage in war that if the command structure of that country were to become compromised, they could enact some kind of global dictatorship of some kind.

Are there any thoughts about that?

Emery: Well, that's just an opinion, I would say. They didn't ever talk about . . . They don't talk about that stuff.

Manufacturers and inventors, and you know, politicians . . . or, I mean, not politicians, but the people that run those corporations, they do not, you know, think about long term.

They're more about who's going to, you know, pay the biggest money, and how they're going to do this, and we need that.

But luckily with this group, they're more compassionate, because they're, you know, . . . about it, because . . . I can't say any more about them, because I'll be . . . my . . . you know, I just can't talk about them personally.

And then, so, . . . but their heart's in the right spot is what I'm saying, and they want to do good. And they don't necessarily need it, . . . you know, to do war.

David: Right.

Emery: And it still hasn't gone that way, yet. But that's where it definitely could easily go.

I don't think any, you know . . . With all the drones out today, and all the other, you know, things we have that do not require a human being to be in to get the job done is where it's going.

David: Right.

Emery: So that's more of a threat, you know, for a drone to drop out of a satellite and be instantly deployed upon an area with stealth mode, and just, you know, . . . that with the simple technology of today. That's so archaic – I call it, but, you know . . .

David: I mean, it really does sound to me, just to summarize, that as Disclosure starts to happen, there are going to be so many surprises that we hadn't even anticipated that just this technology alone is like “Ascension” in a sense.

Emery: It is.

David: Yeah.

Emery: It gives us the ability to travel to the stars.

David: That's really amazing. Well, **Emery**, I want to thank you for being here. And I want to thank you for watching. This is “[Cosmic Disclosure](#)”. I'm your host, [David Wilcock](#), with our special guest, **Emery Smith**.

Cosmic Disclosure: The Dangers of Being an SSP Whistleblower

Season 9, Episode 12

David Wilcock: All right. Welcome back to “[Cosmic Disclosure](#)”. I'm your host, **David Wilcock**. And here again with me is **Emery** Smith.

Emery, thank you for being here. I really appreciate it.

Emery Smith: You're welcome, Dave. Thanks for having me.

David: One of the things that we have talked about on [Cosmic Disclosure](#) greatly is this idea of a Secret Space Program. We haven't really covered that yet.

Now, you have confirmed the existence of reverse-engineered craft, so one would conclude, or one would be thinking to conclude, that if we have craft that are essentially space-faring vehicles that came here from other solar systems, or maybe even other galaxies, and we can build those, that we would then be able to leave Earth and potentially settle somewhere else.

So do you have any direct briefings or knowledge about that aspect of what may be going on?

Emery: Well, there is [are] laws out there, and there is a type of federation involved, from what I was briefed on.

And it's not a “you can just go . . .” Just like you can't just go from here to Europe without a passport, and a couple of weapons, by the way. So this is also applied to intergalactic travel.

So, yes, we do have the ability to “take ET home”.

David: As Ben Rich says.

Emery: As Ben Rich said. But the ability to actually do it is another story until we start behaving a little bit more proper here on the planet Earth and with evolving our consciousness and stop killing each other, which they all understand – extraterrestrials – because they were here, at one time,

themselves.

So getting back to your question, yes, we have these craft. Yes, they are anti-gravity, and they can travel through space, but they're not interdimensional yet, that I'm aware of . . .

David: Okay.

Emery: . . . so I've not been briefed on that. I know of people [who] say they do have this, but I'm not aware of it – of the craft.

So they're just using special propulsion units and other means to create a gravitational force for these devices.

A lot of the military devices we have out there, I mean, such as planes and helicopters, those are already installed in these special jet fighter craft.

So what's the best way to hide something is don't change the . . . because it doesn't matter what shape it's in. But that could be an actual spacecraft.

David: One of the things that **Pete** Peterson has shared with me is that there are a lot of new crafts that we've seen in various movies, like “Avatar”, like “Edge of Tomorrow”, in which they have turbo fans on them, which sometimes move. And he said that our Naval ships have all been loaded with these covertly at this time, and that eventually, once they roll out anti-gravity, that the jet engines or the propellers will be replaced with anti-gravity engines.

I'm curious if you've heard anything like that.

Emery: No, I haven't. I have seen different types of schematics for newer craft and ships and for the Navy and Air Force, and whatnot, that do show more of an anti-grav type situation, but not manipulating the current force, because I believe they already have these ready to go. They're just kind of sitting somewhere. And they already have it.

It's just I don't know where it's at, or who did it.

David: Okay. Another aspect . . . which it's a real shame that we couldn't get you on camera with **William Tompkins** – he's now deceased – but you have said to me that you have some insider friends who are around **Tompkins'** age, or maybe a little younger, who might be willing to come forward.

So do you think that maybe with you coming out on this program that this will help to set a trend where some others will now be able to come forward as well?

Emery: Absolutely. I mean, that's why one of the main reasons was to come out was to basically help other people and inspire them to come out and talk and feel free to talk about some of the things they did with the projects, anything from energy to the extraterrestrials to medicine to all these fantasmical, amazing devices and things.

I think by being here, I'm hoping to inspire them, after they see this, to come forward. And I'm going to personally ask them myself to please come forward, or at least invite them to entertain it, or even have a private meeting with you and other people, if they don't want to show their face.

David: Well, and as you've seen, once . . . because I've interviewed so many insiders, once we start talking, all these things pop up.

Emery: Right.

David: And I might have heard something 15 years ago that I'll remember when somebody else tells me the same thing, or something very similar.

Emery: Correct. Right.

And that's what's so interesting, is to know that you worked on a project for so long and had no idea that this person also was working on a similar project halfway around the world.

David: Right.

Emery: And you can actually exchange information finally, freely, without being scared to do so. And just like some of the stuff I explained to you, you already knew some of this stuff.

David: Right.

Emery: And you knew I had . . . We've never even talked about it.

David: Right.

Emery: So for me, it's even a great confirmation, for me, to know that there's others out there that have spoken to you about these amazing technologies and places, especially the places, which blow me away.

David: Like the fact that Ecuador and Antarctica have very similar stuff.

Emery: Yes.

David: Yeah, and I've never said that to anyone . . .

Emery: Wow!

David: . . . and we just had it happen on camera.

I'm curious about whether you, through briefings or through maybe some of the insiders that you personally know, not including the people we've interviewed on Cosmic, are you aware of there being outposts on the Moon or Mars that we use with these back-engineered craft that we have?

Emery: You know, Dave, I've seen and heard a lot, but I don't have firsthand experience to say I was definitely in that spot.

David: Okay.

Emery: I may have been and not known it. But yes, I concur there's something going on there, and that there is some sort of a base set up there, of course, because that goes back to the other stuff I used to work with, with the portals and the other things, that you and I discussed.

Because you never know where you might be, but I did hear many of these stories that you have. But I was never on a briefing, by the way, that specifically said, "We have a base here or a base there."

I've just read a lot of classified documents from other people like me that were involved with that, so it was secondhand information.

David: If you have heard secondhand information, I'm hoping we can get a little more specific, because more than one insider – I think maybe five different insiders – have told me – and this would include

Corey Goode as just one of them, and there were others well before I ever started to talk to him about this stuff – saying that, in fact, the majority of the solid planets and the solid moons in our Solar System have at least some degree of outposts on them now . . .

Emery: Yes.

David: . . . that we can use.

Emery: Yes.

David: So have you heard scuttlebutt like that?

Emery: Yes.

David: Okay. Could you be a little more specific?

Emery: Well, when you say “outpost”, it means a place to get to and go to. And it's usually not on the surface of that planet, so you know.

David: Okay.

Emery: It's on the inside of the planet, and they're using some sort of portal technology and craft to get back and forth from these places, when it is safe to.

David: So some of the rumors that you've heard, like, for example, let's talk about Mars. Have you heard rumors of there being, perhaps, in some cases, very large bases that might even have 200,000 people working at them on Mars?

Emery: Yes, I have heard that.

David: Okay.

Emery: Yes, I've definitely heard that. And it's kind of a known thing. It's kind of actually a joke in the underground.

David: What would be funny about it?

Emery: Well, you just never . . . Like we were talking about earlier, when you're on a conveyor belt going somewhere, going through energy systems, and then you wind up underground somewhere, and

it feels different, like even the atmosphere feels different, what's not to say that they're using these things, and people don't know that they're actually on Mars working there?

David: Well, that's what you and I started to talk about . . .

Emery: Right.

David: . . . after we had described your travel through Sandia into this base where you did the autopsy. I started scratching my head after we did that interview, because you hadn't told me that part before.

Emery: Uh-huh.

David: But others had described the exact same hall as being a portal, and that when you start at the beginning, you're in one place, and at the end, you're in another.

And then I'm thinking, why would they waste 10 or 15 minutes of your shift having you sit on a gondola?

Emery: Right. Yeah.

David: Because they have fast sub-shuttles, right?

Emery: Oh, my goodness, yeah. They have the maglev tubes and the trains and stuff like that.

David: Right.

Emery: But this is a little different. This is like what we talked about.

Yeah, I don't know, but you did open me up to a lot of other questions now that you said that, . . .

David: Right.

Emery: . . . because many other people have also expressed – that worked on these projects – that they felt different from where they THOUGHT they were. And now it makes a little bit more sense.

I never was thinking that, because I was so young at the time and wasn't as educated as I am now about all the stuff they DID have at that time.

David: Well, part of what occurs to me is that if you are potentially, as you said in previous episodes, autopsying potentially multiple bodies in one day, and they're all different. And we're going to get a lot more into that, and how they're different, and what they look like, in future episodes, because you're one of these insiders who's got a very complex testimony that's not going to be done in one or two half-hour episodes at all.

So if we are looking at all of these bodies – you yourself had 3,000 – how many other rooms do you think there were in this Sandia base, where other guys like you were doing the same thing you were doing? Could you speculate perhaps?

Emery: It would have to be, if I look at the levels, five, seven and eight were the levels that were medical for this type of thing.

David: Okay.

Emery: And each one of them had over 300 of these operating rooms.

David: Wow!

Emery: Yeah.

David: So you're looking at over 1,000 operating rooms just in this one base alone?

Emery: I believe so, yeah.

David: Wow! And so that would imply that if you . . . And over how many years did you see 3,000 bodies on the job?

Emery: Oh, my goodness, that was from August of '92 to '95 of June, so probably three years.

David: Basically three years.

Emery: Three years, yeah.

David: So that's like basically 1,000 bodies a year.

Emery: Well, it's tissue samples, not all bodies, remember?

David: Okay. But just to stick with that number for a minute, we could then say that one base alone, and that would be providing it's only one base, which it obviously is not . . .

Emery: Right.

David: . . . that they could be processing over a quarter million different extraterrestrial species on autopsies per year.

Emery: Well, if you did the math, and you were counting each sample as one species, yes. But it could be many samples from one species for a whole wing of 50-unit rooms.

David: Right. It could be a bunch of guys like you doing it.

Emery: But yes, if it was per species, it would be that many.

David: So to extrapolate, if NASA is now saying 40 billion watery, Earth-like planets just in our Milky Way galaxy alone . . . and they kind of slipped that under the radar. I mean, most people haven't even realized that that came out.



The image is a screenshot of a CNET article. At the top left is the CNET logo. To its right is a navigation menu with links for REVIEWS, NEWS (which is highlighted with a white box), VIDEO, HOW TO, SMART HOME, CARS, DEALS, and DOWNLOAD. Below the navigation is the category label 'SCI-TECH'. The main headline reads 'There may be more Earth-like planets than grains of sand on all our beaches'. Below the headline is a sub-headline: 'New research contends that the Milky Way alone is flush with billions of potentially habitable planets -- and that's just one sliver of the universe.' At the bottom left, it says 'BY ERIC MACK / MARCH 19, 2015 12:10 PM PDT'. At the bottom right, there are social media sharing icons for Facebook, Twitter, Facebook (again), a circular icon, an email icon, and a comment icon.

And we've had other insiders tell us that that was part of a treaty with benevolent ETs, forcing our guys to start leaking things like that, to make it easier for Disclosure to happen.

But if there's 40 billion Earths in our galaxy alone, and life seems to be very abundant, and intelligent life seems to be written into the background of quantum mechanics itself . . .

Emery: Everywhere.

David: . . . then even a quarter million bodies, a quarter million species, is not that many . . .

Emery: No, it's not.

David: . . . compared to what could be out there.

Emery: That's nothing. And when I told you the 3,000 number, everyone always gets a little surprised, but when you think about, as you just said it, it's a very small number.

David: But what . . . Okay, if we peeled back the curtain here, **Emery**, and we do a little imaginative speculation, doesn't it appear that your job, and what you personally dealt with, could be the byproduct of exactly the sort of Secret Space Program that we're talking about, where part of the testimony was that there's no money, but that you get paid in trade?

And do you think possibly that those bodies were payments that we were receiving from other groups in exchange for apparently, all this high tech that we're making?

Emery: It's a possibility, yes. And I also have to reiterate, out of the 3,000, over 3,000, samples, I call them, don't forget some of those could have been lab grown. Those could have been just hybrid things they made here.

David: Right.

Emery: So I can't speculate they were all extraterrestrial. I mean, I know a lot of them were of un-Earth origin, but so . . . Yeah, they could be absolutely from some sort of a trade, inside trade thing, going on, to get technology and to learn other things.

David: And the nature of compartmentalization, right, you're not allowed to ask any questions. You're just going in there, doing your job . . .

Emery: That's right.

David: . . . handling this very exotic stuff.

Emery: Yes.

David: What was it like when you'd come home at night having autopsied something very bizarre-looking, let's say?

Emery: It was fascinating.

David: What would you feel when you're lying in bed at night? Were you able to go to sleep, or would you . .

Emery: Yes.

David: . . . sometimes just be . . .

Emery: No, I was fascinated. I'm always intrigued. I was always intrigued about the human body. So for me, it was just a fascinating thing. I wanted more. I was upset that I would have to go and work in a hospital every couple of hours.

So it was really neat to see all this stuff and then go home and say, "Wow! What else is out there?"

And that inspired me to do more things and take more opportunities with the military and other industrial complexes.

And that just opened up so many things, because I had so many answers, like everyone else did. I want to know what's going on.

And I can't believe . . . I don't believe anything I read, see or hear. I can't, because I know that it can all be so modified, especially with the new 3D programs they have on the satellites now.

I mean, they could put another [David Wilcock](#) right here and reflect light and cast a shadow and have light glistening out of your eyes. And you couldn't tell the difference.

So at this time . . . of course, with photoshopping and everything else, it's very hard for me.

So I decided, at a very young age, I'm going to go out, and I'm going to find out for myself.

And I was doing this strictly just to find out for myself what is going on. And all's it did was open up 100 million other questions.

Every time you find something else out, it opens up more questions, which is great, because it inspires me to go ahead and keep moving forward, especially if there's opportunities there where people want me to be part of amazing projects.

I'm very thankful of all my opportunities I had. They were not too negative.

So I think, if that would answer your question of why I did that.

David: Corey Goode has also shared with us that there were factions in the Secret Space Program, and one of them was called the Interplanetary Corporate Conglomerate, or ICC.

And, apparently, they are offshoots of the defense contractors who are manufacturing very advanced technology.

And, apparently, we, humans, have become a go-to-place for many different species to buy advanced technology, like craft.

And he also said that he found out that we apparently are in regular trade relations with some 900 different extraterrestrial civilizations just through the ICC.

So I'm curious if you ever heard back chatter, scuttlebutt, anything like that?

Emery: No. I'm unaware of that, and I've never heard that before.

David: But it's so compartmentalized, right? That's the problem.

Emery: Yeah, I would not know. It's really hard. You're never alone, and you're always monitored. Like I told you, you always have the bracelet on. It's such high security.

I mean, there's hallways there that will cut you in half if you are in the wrong place, without asking questions.

So it's a very simple job if you just follow the dots. Ha, ha. But if you don't, you've got to be careful.

So I didn't really go around asking questions, because I was too excited about getting more security clearances and moving up the ladder to get more jobs in different places other than dissecting tissues.

David: Right.

Emery: And it did. It brought me to the crafts. It brought me to other things.

David: Okay. One of the things that you told me about that I think would be a good point for us to get into . . . I was asking you about the folder, which is this thing that . . . They called it a folder, maybe to reduce psychological impact, but it's basically like an iPad with a little bit flexible . . . and almost totally clear.

Emery: Yes.

David: And you also said that the folder could be loaded. It would tell you what wing, what room, and what being you were going to be working on. They would only give you one at a time.

Emery: Correct.

David: So did the folder have any type of hard drive or storage mechanism?

Emery: Yes, it did.

David: Really?

Emery: I'm surprised you mention that, but, yeah. It's called a micro disk.

David: A micro disk.

Emery: Yeah, it's a little bit smaller than a quarter, but larger than a nickel. It's gold-plated, made of some sort of iridium gold, and there's a little, teeny slot for that.

And it records everything that you're doing.

David: Hm.

Emery: And it also connects to the construct of the base, of the underground ba . . . - what construct is there, like, mainframe.

So that little thing is then taken from you and put on a shuttle, and they store it in space – all the disks.

David: Really?

Emery: Yes.

David: So I would imagine that if you had your folder in the early 1990s, when we're back with the whiny, loud, desktop tower computers, that we're dealing with something a lot more advanced than even what we have now.

Emery: Oh, this is far more advanced than anything that you guys have today, right now. I mean, we're talking high resolution video pictures and millions of documents of information, you know, all on this little small, very, very thin disk.

David: So do you think these disks might have like thousands of terabytes of storage or maybe even more?

Emery: Yes, I would concur to that.

David: So what was the protocol? Did you have to remove the micro disk from the folder and hand it to someone? Or did you just hand your folder in at the end of the day?

Emery: No, yeah, the folders, number one, when you put them in and slide them into this thing, the disk comes out. But you can take that disk out, just like you do today with SD cards or cards for your camera.

David: Okay.

Emery: You can easily take it in and out, which sometimes you had to, because you had to review another, . . . someone else's project.

David: Oh.

Emery: So that's why that was there, so instead of it being automatically downloaded, . . . They didn't like information going [over] a wire, so they use these disks for that.

David: Where on the folder would you insert . . .

Emery: Top right corner.

David: Top right corner. Interesting.

Emery: Yeah.

David: So I guess you could see it then, because it's . . . You said it's a gold color.

Emery: Yeah, you could see it inside. And it has like an iridium tint to it.

I always wondered if they did that to protect it from the radiation of space, since it was stored in space, they said.

David: Was there any way to access the information on the disk other than the folder?

Emery: Yes, there is one way.

David: Hmm. Is there some kind of reader or something?

Emery: There is a disk reader, yes.

David: Really? And I guess the reason why they haven't given us that kind of storage technology would be what? Why don't we have that level of data storage if the technology exists? Why would it not be shared with the public?

Emery: Because then you won't go out and buy a 256K phone.

David: Ha, ha, right. It's just too far advanced from where we are now.

Emery: They won't make any money, these corporations. Come on.

David: Right.

Emery: I mean, we have to start really, really small for these corporations. They already have it, but we're not going to get it right today.

David: It seems like . . . If you see the movie “Snowden”, allegedly, he was able to get one of these little USB sticks inside a Rubik's cube, . . .



. . . and then he tossed it to the guy, and he went through the gate.

Emery: Right.

David: Do you think anybody has ever tried to get a mini disk out of the base?

Emery: Yes.

David: How might that be done?

Emery: It's tricky, but can be done, yeah.

David: Okay, you don't want to go into that.

Emery: Well, I had a few of the disks, yes.

David: You did?

Emery: Micro disk, yeah.

David: How might somebody be able to do that?

Emery: Well, I'd rather not say that part.

David: Okay. Okay.

Emery: Ha, ha, ha.

David: Ha, ha, ha.

Emery: But I have acquired a few of those disks, yes.

David: And when your house was broken into, were those some of the things that were taken?

Emery: Yes, they took the disks.

David: Really? So you did have them . . .

Emery: Yes.

David: . . . but you lost them?

Emery: Yes.

David: Yeah, that was very, very unfortunate.

Emery: It was very unfortunate – very angry about it and upset.

David: Could you tell us a little bit about what happened to your house, and where you had stored those disks, and how were they found?

Emery: Oh, sure. So I had a small home in New Mexico that was gated with an iron gate and concrete post and a keypad, the whole thing. A very small, small home that I temporarily got just to store some

small belongings and stuff, because I was working on a project out in southeastern New Mexico, and I was there for about a year, nine months. I had this place.

So what I did was: I, of course, . . . I don't keep all my stuff in the same spot . . .

David: Right.

Emery: . . . and I keep some duplicates, but there's no duplicates to this. I can duplicate some things, but a lot of just information on hard drives, and whatnot.

And I got a call, because I was going to be moving to Los Angeles to be with you and work on some other projects.

David: Yeah.

Emery: So I told the realtor, “Hey, I'm going to be moving.” So they put it up for sale, and I was just leasing the place at the time.

And I had basically hidden all my stuff inside the walls of the house, and you couldn't tell where they were – also in the concrete and other various places. I don't want to talk about other specific places, because I still use those techniques.

But I thought it was safe temporarily for this.

I also had the overunity device there, which, fortunately, I went to go pick up. And it was within a week that the house was ransacked. And another week later, it was ransacked.

And that's when the realtor called me and says, “Oh, my goodness. I looked through your window. You left your house such a mess. How am I supposed to show anybody?”

And I said, “My house is perfectly spotless. I don't understand.” And I said, “Please, go around the house and look around.”

And he did, and he found the back garage door was broken into. And then the double bolted locked door to the main home was kicked in with a big footprint. And we have all the pictures.



David: Let's roll right now the film that you took.

Emery: Sure.

[Emery's comments on the video clip of the break-in to his house:]

"This is the garage – complete destruction. Took all the equipment. The lab has been completely destroyed."

David: So why do you think whoever did this would take everything you've got and leave only your military badges in a box and a bullet on the countertop? What was the message?





Emery: Oh, I think they were just some old friends trying to look me up to have a good time. Ha, ha.

So I think it really had to do with the device, number one, because ever since I started the lab with the device, it's been getting . . . it's been getting really crazy.

And now that I proved the device worked, then it got really crazy.

And, of course, they used a satellite and found out all the stuff underground and in the walls.

David: Right.

Emery: And they did cut the walls open and take all those hard drives and everything else.

We're talking about 8 computers, 12 laptops, 40 hard drives, over 300 SD cards, lots of information – my world's . . . my whole 30 years of work.



David: What's the purple tip?

Emery: Oh, oh, it's just the type of bullet it is, yeah. It's a very high velocity bullet.

David: Okay.

Emery: It's not normally a civilian bullet that you can buy from civilians.

David: Okay.

Emery: And it was a 5x7x28 armor-piercing ammunition, which is used by tactical forces all around the world.

David: What could you say to other insiders who would hear a story like that and say, "Well, my god, if they start doing that to me, the first thing I'd do is go into hiding, and I wouldn't speak?"

Emery: Well, let's talk about it, because I wasn't going, at that point. I wasn't.

So I think the information, too, that I had was . . . I couldn't see . . . I couldn't really see the information that I had, . . . like 90% of it was pretty much just already out there stuff.

David: Right.

Emery: So I think it was just that 10% AND the device that, “Hey, just why don't you slow up a little bit, because you're going on a trajectory here that looks like you're going to say something that you shouldn't say.”

David: Right. So they were trying to threaten you.

Emery: Yes.

David: Do you think that anybody who comes forward is safer than if they don't, if they're already starting to speak a little bit? Is it safer to be public?

Emery: Yes. At a certain point, you have to go public. It's very . . . It's much safer. We all know this, and this is one of the main reasons I'm here in front of you right now.

David: Right. All right. Well, there you have it. This is **Emery** Smith, and I'm **David Wilcock**, “[Cosmic Disclosure](#)”. And I want to thank you for watching.

Cosmic Disclosure: Tragic Consequences Aboard a Mayan Ship

Season 10, Episode 1

David Wilcock: Welcome back to “[Cosmic Disclosure](#)”. I'm your host, **David Wilcock**, and I am here with **Corey Goode** for some very exciting updates coming from the cutting edge of our Solar System's transformation.

Corey, welcome back to the show.

Corey Goode: Thank you.

David: Could you tell us what exactly has happened to you? Just give us a broad summary of some of the talking points of what occurred to you back in December 2017.

Corey: Let's see. I've received quite a number of briefings from the Earth Alliance over the last three months.

And also, the SSP Alliance has been popping up a lot more and showing their faces again.

David: Hm, that's good.

Corey: And I also spent some time with the Anshar.

David: Could you just walk through with us how this whole new chapter had started for you, because it kind of seemed like things had gotten quiet for a while?

Corey: Well, they did, but I guess a lot of the . . . for about 10 weeks, I was receiving dream-type of information that I needed to prepare for a major meeting with the Blue Avians and the Super Federation.

And they also warned me that I needed to prepare for a meeting with the . . . I think they called them the Council of Saturn, . . .

David: Right.

Corey: . . . which was going to be an introduction to two of the new Guardian species.

David: Sure. And both the terms, "Council of Saturn" and "Guardians", are used extensively in Law of One material. So that's very interesting.

Corey: Correct.

David: The first of these adventures that you had actually happened in mid-October 2017. So could you describe for us what took place then, and how does this all begin?

Corey: Correct. We were preparing to move, and my wife had been very busy packing crates and boxes. And it was about 3:00 in the morning or so, I was sitting in my living room with boxes and crates everywhere.

Suddenly, there was a flash. And now I'm up on the Mayan ship.

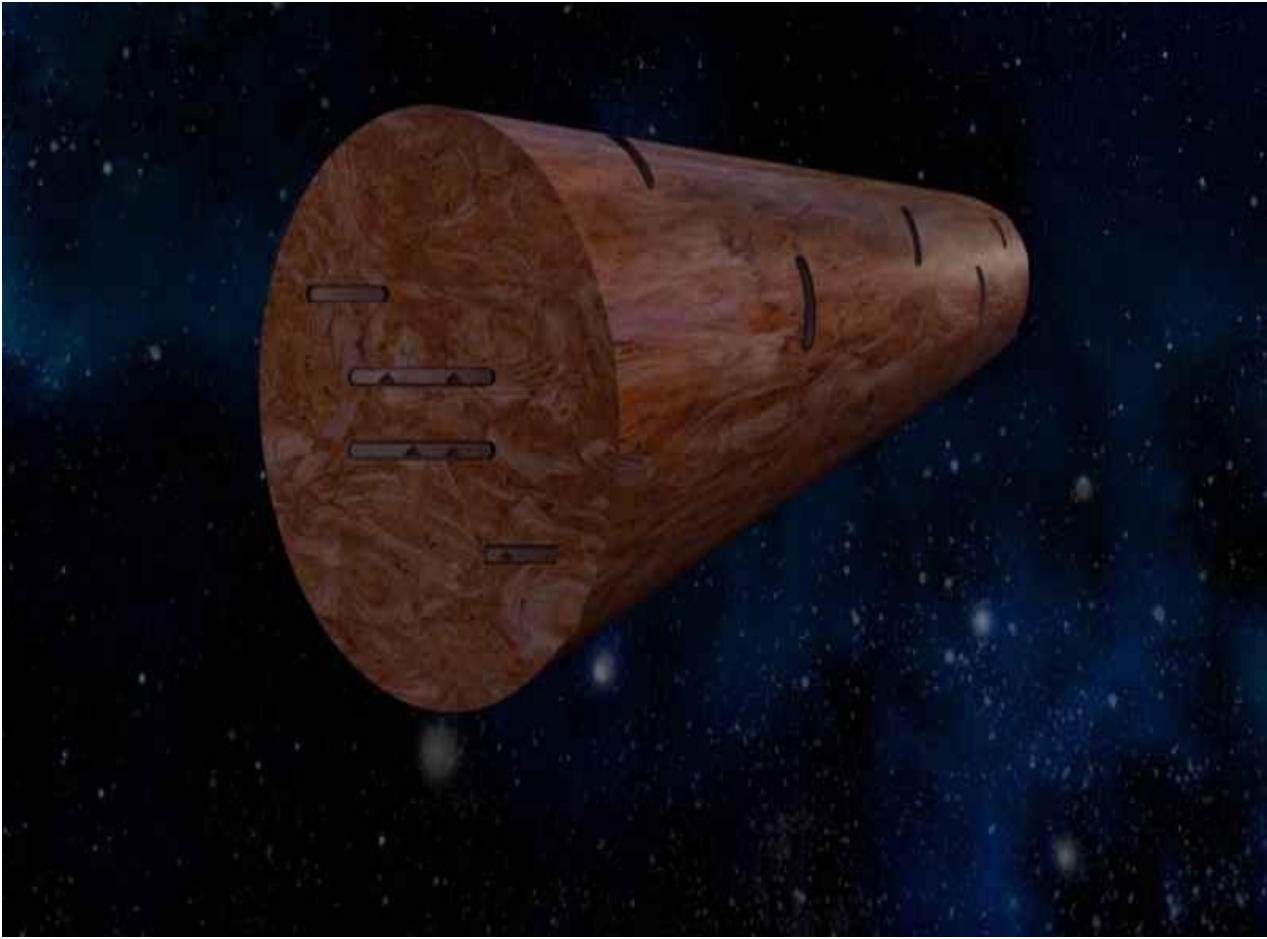

But I found myself in a very distressing situation on the Mayan ship.

Normally when I go there, it's very serene. I'm guided to a room where, you know, I'm examined, and they do work on me for this temporal dementia issue that they're working on.

But this time it was a very frantic environment. It was strangely quiet. But immediately, Gonzales grabbed me by the elbow and started pulling me towards an open door – one of the double-wide doors – going into the exam area.

So he grabs me by the elbow, and he's pulling me, and he's telling me, “There's no time to explain. I just need you to go in and let yourself be seen.”

And I had one hand on the bulkhead, and my feet planted, and he's pulling me, and I'm asking, “What's going on? What's going on?”

And he . . . I think he's about to explain it to me when he tells me, "You just need to be seen." And he shoves me through the door.

As I was being pulled towards the door, I saw Mayans going in, and they had these weird things in their hands that look like . . . kind of like an ax head – like a double-bladed ax head.



But, I mean, it wasn't sharp. It was just the shape of it.

And they were holding them in their hands like this [**Corey** has each hand on each edge and holding the ax head in front of him with the flat surface facing the enemy], kind of like a shield and a weapon, and they were holding it up and walking in, kind of hunched over.

David: Hm!

Corey: So it was obvious something different was going on.

David: Well, that's kind of strange because you typically describe the mood there as being very high vibe and healing and peaceful.

Corey: Yeah, it's normally very serene. And this time, I mean, like I said, there was a very frantic energy.

Once I was shoved through the door, I saw why. I looked, and, peripherally, I saw Mayans laying on the floor with those ax-head looking instruments, weapons, kind of just bobbing up and down floating.

David: Hm.

Corey: And they were obviously dead. Their bodies were contorted, and they were obviously dead.

But what caught my attention was across the room: This being that was in somewhat of a mirage-effect-looking field that was like a bubble. And he was floating above the ground.

And he was a Reptilian, but he had very human-like characteristics, I mean, human-looking lips, the cheekbones.



David: Hm!

Corey: It looked like snakeskin stretched across a human type. It had a slightly elongated skull.



Its eyes were yellow, and it had black slit pupils.

Just like with the white royal Reptilian, the one that psychically grabbed my mind, . . .

. . . its pupil was doing this [**Corey** moves his thumb and forefinger together and apart] – opening and closing at a rhythm.

And it was wearing . . . It didn't have shoes on, but it had black almost with metallic-sheen-looking one piece that almost looks like how yoga pants kind of cling to you.



David: Hm.

Corey: He was wearing that. And then he had a cape – a pretty intricate cape. And he was floating above the ground, and his eyes were [opening and narrowing], you know, . . . And the Mayans were engaged with him.

And I thought I was about to interface with him.

And what happened was: He turned his head to look at me, and his eyes went, “Vwoom!”, yellow, solid.

And he started to address me by the “Hanush” name that they use for me.

And right when he was about to address me by that, I heard a loud “snap”, and he fell to the ground.

David: Hm! So this would imply that he was distracted by you being there enough that they had just this little narrow window to take him out.

Corey: Right. I thought I was being brought in to negotiate or communicate, but I was being brought in as a distraction.

David: So this is a really interesting point here. When this Reptilian calls you by this name, you say “Hanush”, and what it sounds like to me is “Chanokh”.

When I say that, does that sound right to you? Have you heard it pronounced that way?

Corey: Right, right. They pronounce it all a little differently. It's a name that they've called me from the beginning, but when they call me the name, I don't feel this huge energetic connection or ego connection to.

David: Right.

Corey: But from the beginning, they called me Raw-Hanush, or Chanokh.

David: Chanokh.

Corey: Yeah, -Eir.

David: So the reason why I'm saying that so specifically is that this is actually a Hebrew word that most people would identify as "Enoch". And you've seen me present on the Book of Enoch, and the really interesting thing about it is: It's as old as the book of Genesis.

It's very interesting because it talks about giants on Earth being cannibals and that the Great Flood was created to cleanse the Earth of them after all the harm they were doing to humans.

Chanokh, in that book, was the person that these evil beings, that they called "The Watchers", used to communicate with the good guys, who were called the "Elohim".

So when we actually studied the etymology of Chanokh, it means "messenger".

Corey: Right.

David: How does this strike you? It seems like there's no accident that they gave you that name.

Corey: No. And, I mean, from what I've gleaned is that this is not . . . It's a title. It's not a name.

I'm not saying that I was Enoch, and I'm back, you know.

David: Right.

Corey: Far from it.

Whenever I've talked to the Blue Avians about reincarnation, they always say, "We are one, or we're not all one".

David: Right.

Corey: [It's] one of the two. So no, it's more of a title.

David: What was the connection between this Reptilian being and this title of "Hanush" or "Chanokh"?

Corey: Well, he recognized me as that position, and he was either taken off guard, or he respected the situation enough to where he probably thought he was about to have a dialogue that he disengaged a battle and turned his attention to me, when obviously that can be deadly.

David: What was the idea, then, of how he got there? And what was going on with this story? Did you get any information?

Corey: I did, but a little bit . . . I'll give it right now because some of the information I received later on, because things occurred so quickly, even after this.

David: Hm.

Corey: What had happened is that the Mayans had picked up this political prisoner from somewhere in the southern part of Africa.

And they had gone in and done an operation and removed it. But from what I'm told, they overestimated their abilities and underestimated that being's abilities.

They thought that they were going to be able to bring it up in a flash, and then put it immediately into stasis, and it didn't work out that way.

David: Now, Africa, meaning like an underground base of some kind?

Corey: An underground city, I'm told.

David: Hm. Did you get any information as to why it looked like it was a human-Draco hybrid?

Corey: No, but like I said, I had never seen this type before. It was obviously very important.

David: Right.

Corey: You know, it looked like a prince or something.

David: Was it more of a conventional height compared to us than the other Draco that you saw?

Corey: Yes. He was about 6', 6'6" tall.

David: Okay.

Corey: And the bone structure was very human.

David: So what was the next thing that happened? You said it was moving very quickly.

Corey: Right. Well, apparently, they were doing some sort of a prisoner transfer that went bad. And I was brought in in the middle of this.

And Gonzales was like, “Hang on. It's not over with yet. Just let them see everything that you saw.”

And I don't know who “they” are yet.

Gonzales is trying the best he can to explain what's going on, and there's no time.

Basically, he told me about that, “We were doing a prisoner transfer. It was very important that we delivered this being alive to where we're about to go.

“We need you to open your mind and let them see everything.”

And before I could protest, ask any more questions – another flash!

He was looking over at one of the Mayans in particular. The room was filled with them.

He was looking over at one of them that was over at one of those consoles that had the flashing symbols on it that floated.

And then we ended up in the cavern.

And the being that was killed was like 20, 30-feet away from me at least – its body.

When we appeared in the cavern, it was at my feet. And its cape was spread out, kind of, and flipped over its head.

David: You're seeing this body in front of you, but they had covered over the face?

Corey: No. Well, it's just kind of how he was laying – haphazardly. He was laying kind of on his back up against a rock that he appeared on top of, kind of this way with his arms together, and the cape was out across . . . out and then over his head a little bit. It was just kind of haphazardly the way he was.

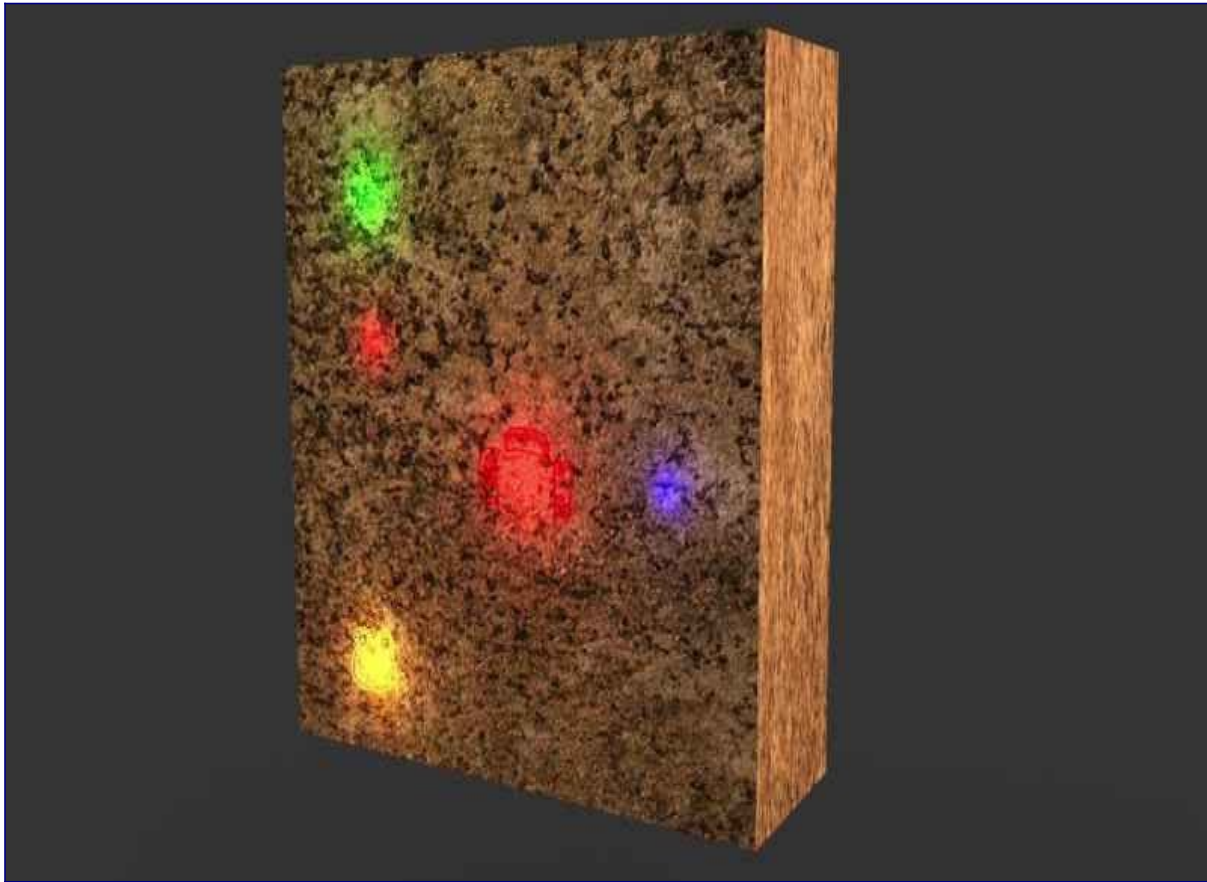
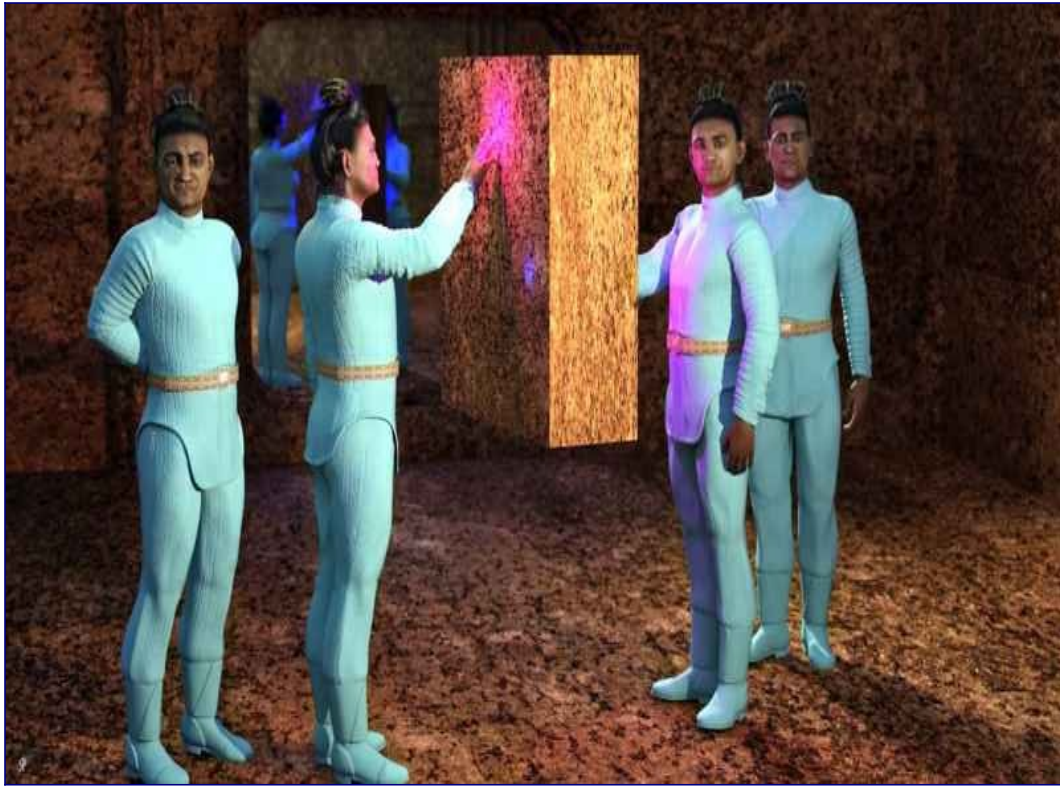

David: Okay.

Corey: The cape was white, green, brown and blue – the colors. And over one shoulder was the tail of a white snake, and it went down the back of the cape and went up and down several times, like four or five times.

And then the head came up over this shoulder [**Corey** motions to his right shoulder] and was like this with the tail. [**Corey** has his right hand, representing the snake head, on his chest pointing toward his left hand, representing the snake's tail, which is on the left side of **Corey**'s chest pointing toward the “head”.]



And the overall cape was blue and looked kind of like water, like a water background, and the white snake undulating up and down.

Then you saw brown stems coming out of the snake, like the snake was some sort of plant.

And then there were these very bright, huge, fern-like green leaves.

David: Were you alone in this cave? Who else was there?

Corey: No, there were a handful of the Mayans, and then Gonzales and myself.



David: Okay.

Corey: And we look up and there are like two plateaus – cavern wall and two plateaus. And about this large [**Corey** has a thumb and forefinger spread about three inches], these figures came walking out.

And on one side I could tell they were Nordic-looking. And there were also what looked like the Ebens, a little bit, kind of orangish skin and a pear-shaped head.

David: Just to be clear, when you say “about this large”, that's just what it looked like from your vantage point.

Corey: Perspective. Right.



David: Okay.

Corey: Right, perspective. You know, they were about [appeared to be about 3” in height] . . .

David: Sure.

Corey: . . . about like that.

And then on the other side, these weird Reptilian-looking beings came out, but I couldn't see the details. I could tell there were a couple of different types.

And on both sides, they kept turning back like they were looking back to someone, like looking for approval or reporting or something.

Then immediately, they all, in chorus, began to communicate or connect with my mind. It was like a chorus . . . It was an interesting . . . It was a little bit different than what I've had occur before.

And then they replayed the scene from when I appeared on the Mayan ship over and over and over in my head, like many, many times. And then they disengaged.

And when they disengaged, I looked over and saw Gonzales and a couple other of the Mayans that were going through the same process.

David: So they're replaying the scene. Did you get any sense of an emotional temperature? What were they feeling about it? Were they happy about it? Were they sad about it?

Corey: Well, the Mayans were upset because we were supposed to deliver this being alive.

From the other beings, I didn't get any type of hit.

David: So was there any other information they conveyed to you besides just replaying the scene? Did you hear any . . . ?

Corey: No.

David: Okay.

Corey: They were just there using me as a USB drive, basically.

David: Hm. Just reviewing what was in your head.

Corey: Right.

David: Was there something unusual about the way they accessed you telepathically that was different from what you've experienced before?

Corey: Yes, it was all of them at once. It was like a chorus.

And then some of them wanted to see it again, and others were wanting to see different parts. So it was disjointed the way it was playing back in my head. It wasn't playing back linearly all the time. It would jump around.

David: So after they interfaced with you, what happens next?

Corey: I am sent home in the same flash.

David: Really?

Corey: No explanation.

David: No information.

Corey: Nothing.

I've met with Gonzales a couple of times since, but haven't had an opportunity to really get into the details about who that being was. You know, he was obviously very important.

It'd be interesting to see if there's any intel out there about a missing being from that city in Africa.

David: As a general overview, it would seem to me as if this type of political prisoner wouldn't have been captured if there weren't already some major victories for the SSP Alliance.

So could you just try to again speculate as to . . . Would you say this is a kind of far-along development in this war – like a sort of endgame final conclusion-type of development?

Corey: Yes, it's definitely . . . and a lot of my briefings have kind of dwindled because we're in an operational phase.

David: Right.

Corey: The Earth Alliance is out there operationally working on ending this Cabal/Deep State.

Now, on each level, we have the same thing going on. We have, you know, the SSP Alliance sees an opportunity to come back now.

A lot of key people were either killed or disappeared from their organization.

David: Right.

Corey: And they've had a few new interesting additions that we'll be talking about later.

David: You had mentioned before that there's an optimum timeline where we get Full Disclosure.

It's really interesting to me to note the parallel between this apparently very high-level Reptilian being being apprehended by the SSP Alliance, and then the briefings we've gotten terrestrially about more and more high-level Cabal people being apprehended here on Earth.

From what you've heard from the SSP Alliance, and we can take it right up to today, do they feel that we will be able to get Full Disclosure and not be stuck on a 50~100-year Partial Disclosure?

Corey: Well, that's the goal of the SSP Alliance. And they have a few tricks up their sleeve that I'm not going to go into that they are going to pull out if a Partial Disclosure narrative is pushed.

David: Hm.

Corey: But for the most part, the Earth Alliance and the Military-Industrial Complex Secret Space Program, they're under the agreement that the public cannot take all of this information dropping on them at once.

They think that it has to be drawn out over 20 to 50 years.

David: Based on your experience of us reaching millions of people, do you think that's true?

Corey: No. I mean, it's obviously going to be a rough time. We've talked about it before.

You know, it's not going to be a kumbaya moment where everyone holds hands and sings. It's going to be more of a time of rage and dealing with karma than anything.

David: Do you think that a Full Disclosure timeline would include people finding out that many of us here have extraterrestrial genetics and home groups, and that we are being abducted by our home groups and then re-abducted by this SSP?

Would that be part of the Full Disclosure if that were to actually happen?

Corey: It would absolutely be a part of the Full Disclosure. And a lot of these, I guess, our cosmic cousins from the local 52 stars in the local star cluster, are not going to let a Partial Disclosure occur.

A lot of these groups have been told that they have to disclose ETs, or the ETs will disclose it. And many of them are the people that are waiting to come down and assist us.

David: So can we move forward, then, to the next event that happens to you that's of significance?

How did you feel about being used to kill this being?

Corey: Well, it happened so fast I really didn't really know what was going on until the snap happened. It was a very audible snap.

David: Was this a neck that broke, or . . . ?

Corey: Yeah.

David: Okay.

Corey: Yeah, his head was all twisted and contorted around.

David: Really?

Corey: But, I mean, I thought I was about to interface with this being. I wasn't looking forward to it, because I was flashing back to that royal Draco.

David: Absolutely.

Corey: I wasn't very happy that I was used. I felt used. But at the same time, I was able to kind of rationalize why and what happened.

David: So let's just be clear on something here, and please don't take this the wrong way, but you don't have superpowers. I don't have superpowers. We're just regular people who have gotten into these strange positions.

Why do you think they would take a regular guy like you and throw him into this kind of role where he is THE intermediary between the bad guys and the good guys?

Corey: A lot of it is not being an intermediary. A lot of it is just being a witness.

If they have me witness something on behalf of our collective consciousness, it enters into my consciousness and then filters out into everyone else's consciousness.

So that's some sort of cosmic law thing that they have to do when they're working with groups.

David: So this Reptilian being, they were trying to keep it alive. And if they had kept it alive, what would have been the end game there?

Corey: First of all, you can always gather intelligence, you know, from the interrogations. But the reason they wanted it alive is that beings at this level are so advanced that if you kill them, they'll just reincarnate with the full knowledge of who and what they are into another life form.

David: Hm!

Corey: So it's kind of a little trick. They anchor the consciousness to the body by putting them in a cryogenic-type sleep, or stasis.

David: Weird.

Corey: And that's another weird cosmic law kind of thing that I don't fully understand.

But the interesting thing is that in our Solar System there are a number of, some of them very ancient, prisons, one of which is an asteroid that's been hollowed out. And it's full of cryo-prisoners.

David: In the Law of One, they always are talking about First Distortion of The Law of One – First Distortion, First Distortion. And they keep bringing this up.

And they say it's the main law that the universe is founded on. And they say that that is Free Will.

So how do you think this concept of the First Distortion, how they're always trying to protect the First Distortion, would relate to the fact that the SSP Alliance had to talk to the Guardians through you, the fact that the negative beings have to talk to the Guardians through you?

How do you think that preserves Free Will? Why do they have to do it this way?

Corey: Well, I mean, they do everything in a weird way – I mean, even how they approached me. They had to approach me in dreams at first. And then basically negotiate with my higher self whether I would get any type of physical encounters or what I would have to do to prepare for them.

So it's a path. It's always a path.

David: I find it really interesting, **Corey**, that you have the SSP Alliance capturing really high-level prisoners now, maybe for the first time. And it seems that the Alliance here on Earth is also capturing high-level prisoners for the first time.

Could you give us some sense of what those developments are on Earth, and where this is taking us in the short term, or the fairly short term?

Corey: Well, the developments on Earth are going to need to catch up to the developments that have occurred recently in the heavens, I guess you would say.

And, you know, we'll cover in detail the fact that humans are going to be given an opportunity to govern ourselves, to not have to deal with alien races coming and tinkering with our genetics.

There's a new Golden Age that we're going to be presented with, and how we handle entering into that Golden Age is going to pivot what kind of a temporal reality we're going to end up in. But WE will be in control. We won't be managed. We're going to be self-managing.

David: So once we have freed ourselves from Draco rule, how does that affect the basic way that our society runs – like, let's say education, government, medicine, philosophy, religion – things like this?

Corey: Well, what we're seeing on Earth is the beginning of them taking out this control system and mind control system.

When, like I said, the Earthly events catch up to what's going on cosmically, then we are going to have an era of open information.

We're going to receive the correct physics models, the correct mathematic models. We're going to learn a lot more about our cosmos, and we're going to become a part of this cosmic neighborhood as an interstellar civilization.

It's going to be a very exciting time for us.

David: Well, that's a really positive message. And I want to thank you, again, for your bravery, stepping forward and giving us this message. And I want to thank you for watching.

This is “[Cosmic Disclosure](#)”. I'm your host, [David Wilcock](#), bringing you the latest updates with **Corey Goode**.

[Cosmic Disclosure: End of the Super Federation](#)

Season 10, Episode 2

[David Wilcock](#): Welcome back to “[Cosmic Disclosure](#)”. I'm your host, [David Wilcock](#). And here again with this fascinating interdimensional adventure is **Corey Goode**.

Corey, welcome back to the show.

Corey Goode: Thank you.

David: So, where we last left off, you had had an experience regarding this Reptilian being you hadn't seen before, where you were used almost like a pawn in some greater cosmic battle.

What happened after this weird experience?

Corey: Well, I was still meeting with Gonzales on a regular basis, and it was mostly of a medical nature.

But it was soon that I started having these dreams to where I would dream that I was back on one of the Spheres. Or I would dream that we were in my living room conversing.

David: “We” who?

Corey: Teir-Eir.

David: Okay.

Corey: Right, the main Blue Avian that I communicate with is Teir-Eir.

David: Okay.

Corey: And he had been approaching me in dreams. And a lot of them would be . . . I would be having a normal dream, and then it would just morph to where he was there.

So if I was having a dream that I was on the countryside, just as an example, all of a sudden, he would break into that dream and then kind of . . . It would be taken over.

David: Hm!

Corey: And basically, what he was preparing me for is that he said: in a number of days, I was going to be brought up to meet with the Super Federation to where Teir-Eir would be present.

I would be basically, interpreting or delivering a message for him. And then shortly after, I would be going to the council at Saturn to greet the two new Guardians.

David: And at this stage, did you have any sense of what “the two new Guardians” meant – what that actually would be?

Corey: Yes. For three years nearly now, or more, Teir-Eir told me that at some point, the Blue Avians and the Golden Triangle beings were going to fade out of our reality, and a new guardian, that was a part of the Sphere Being Alliance, was going to come in and assist us from that point on.

David: Was there a sense that there was going to be some stress for you in doing this meeting?

Why was so much preparation necessary in this case?

Corey: When you hear that there's a meeting of this type going on, there's always stress involved leading up to it, because they never give you too much information beforehand.

Usually, you are just thrust into a situation and have to deal with it.

David: So when exactly did this next big meeting happen that you were being prepared for?

Corey: Well, on December 16, 2017, in the middle of the night, when I got up in the middle of the night, a Blue Sphere appeared in my room.

So, you know, that's about the type of warning you get.

I had some clothes laid out that I had out for a couple of days that were nicer – more like the clothes I would wear on “[Cosmic Disclosure](#)” – . . .

David: Right.

Corey: . . . because it sounded like an important meeting, and I didn't want to show up in my underwear again, ha, ha, ha, which has happened.

David: Ha, ha, ha. Indeed.

Corey: So they . . . I got up. I got dressed, and the Sphere took me away.

David: So walk us through what happens now. The Sphere picks you up.

Corey: Yes.

David: And where do you end up next?

Corey: I end up on the Super Federation, just outside the . . . in the foyer, just outside the main doors to the meeting hall, where the stairs go up to the main doors.

And there are plants that are around at the bottom of the stairs. And I appeared down close to where the plants are.

And I didn't know where I was for a moment. So I kind of stepped behind the plants a little bit to get a little bit of cover, but then I saw Gonzales and a couple of the Mayans standing not too far away.

David: But I guess you had been prepared already in these dreams that there was going to be a Super Federation meeting. So then you realized this is what you had been prepared for, correct?

Corey: Yeah, but when you say “prepared”, they say that there's going to be a meeting. And that's all the preparation you get . . .

David: Ah.

Corey: . . . no other information.

David: Okay. So who spoke to you first, and what happens next?

Corey: Gonzales saw me standing over there looking all awkward and immediately left the two people he was with and walked directly to me.

He grabbed my shoulders and shook them, and he said, “Are you ready for this?”

And I said, “Ready for what?”

David: Ha, ha.

Corey: I have no idea what's going on. And he was just . . . He was smiling, and he was very upbeat. And he was saying, “That's typical!” - that kind of thing.

David: So where does he take you? What happens next?

Corey: Well, we walk up all the stairs, go through the main door, the middle door, and as we do, the assembly room is packed. It is . . . I've never seen this many beings there.

And, you know, there are a lot of ET beings that you would think of that look completely different from humans. But then there were a lot that looked very human that were there.

David: Very human meaning passable – that they could be walking down the street?

Corey: You know when Columbus visited the United States for the first time and saw the Native Americans there, they had never seen that type of human.

David: Right.

Corey: And this is the same type of experience. You're looking at just a different race or type of human.

David: Hm. Okay. So it's really crowded. And what was the mood like in the room?

Corey: There was a lot of excitement.

And it was not quiet in that room. There was a lot of moving around, murmuring.

But as I was being led, he was leading me through the crowd in this open walk area towards the chair that was designated for us.

And what I'm talking about is there are horseshoe-type seating arrangements to where there's a main chair that's a little bit raised, and then three smaller chairs sitting below in a half moon.

And we were walking towards the one that was designated for us.

And as we were walking past, I look over to my left, and there are five aquatic beings that I've never seen before.

There was a cylinder, like an atmospheric cylinder, floating off the ground about maybe a foot or two, that was just water.

David: Hm.

Corey: There was no glass, no apparatus hooked up to it – nothing. It's just water in like a force-field cylinder. And in it were these aquatic beings.

This being, when it was in the water, it looked like it had feet, but they were sort of like walrus feet. It was like a walrus tail.

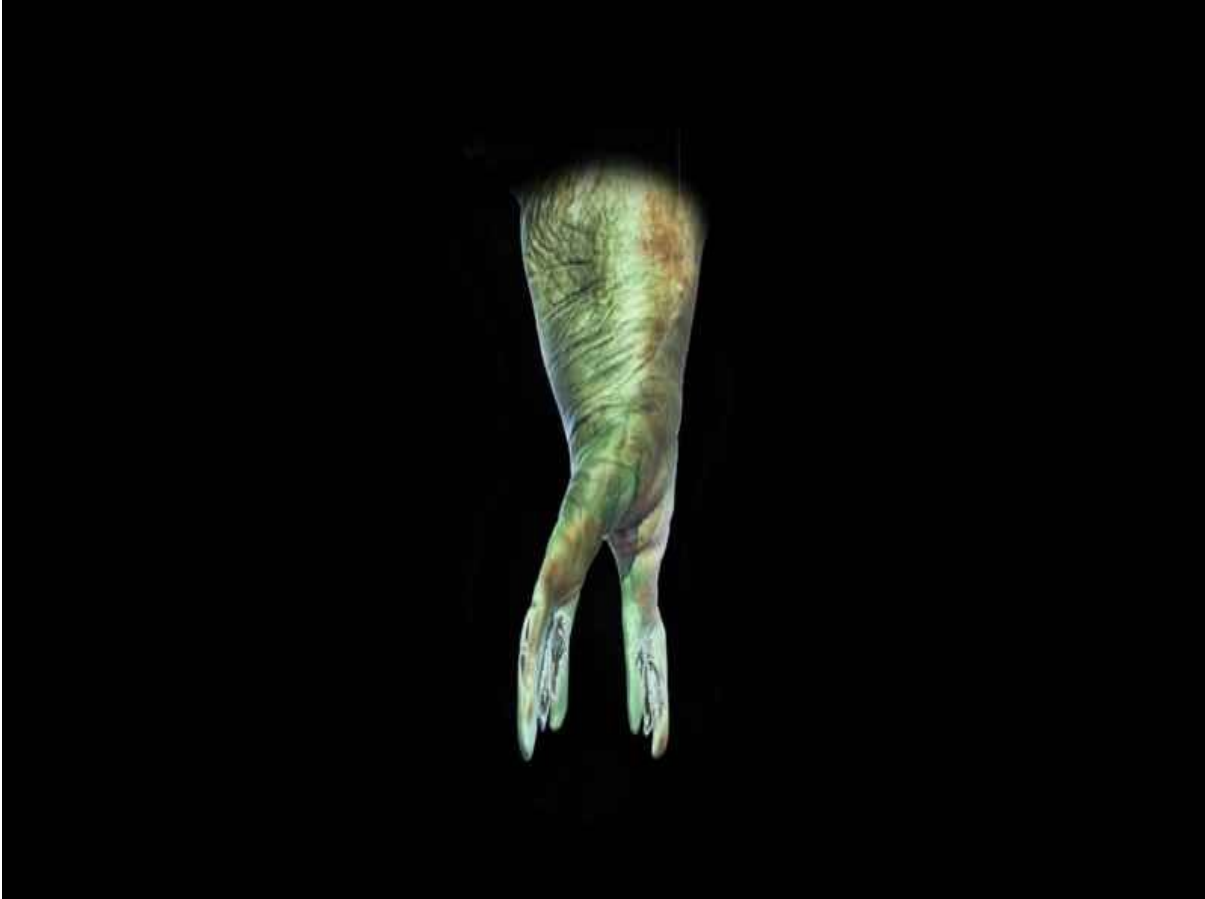

When it didn't have its tail fanned out, it looked kind of like feet hanging. And then to keep its position up and down, its tail would fan like that [*Corey releases all his fingers of both hands toward the floor and then close them and then repeats the motion*] to help keep it up and down.

And it looked sort of like a walrus body moving up to the torso.

And then when you get to the head, it had like these . . . It was almost like manatee lips on both sides, very large, that would open its mouth into a curve, into an oval like this, [*Corey creates an oval with both hands*] to suck water in.



And then it was shooting water out two jets on the back of its neck, behind it, where its ear would be.



This was keeping it up and down the way it wanted to.

David: Let's talk a little about the eyes and the way the rest of the head looked for a moment.

Corey: The most striking thing was this balloon-looking thing floating above its head. It had some sort of a cord connecting right where its third eye is, with this very large balloon that was filled with some other kind of liquid.

And when he would turn his head, it would move too. It would like of like slosh, move around, as he would turn his head.

And it was obvious that this had something to do with the way it was communicating and also maybe mapping out its environment.

David: Hm.

Corey: What was interesting, though, is when it did . . . and it didn't communicate very much, but it did have a couple of outbursts later, to where little flashes of light were popping in the water around it.

David: Hm. So it might have been bioluminescent in some way?

Corey: In some way, but it seemed as though whatever was occurring with it mentally was causing this to happen.

David: Hm.

Corey: The other being gave me the creeps immediately.

It had very sharp needle teeth.

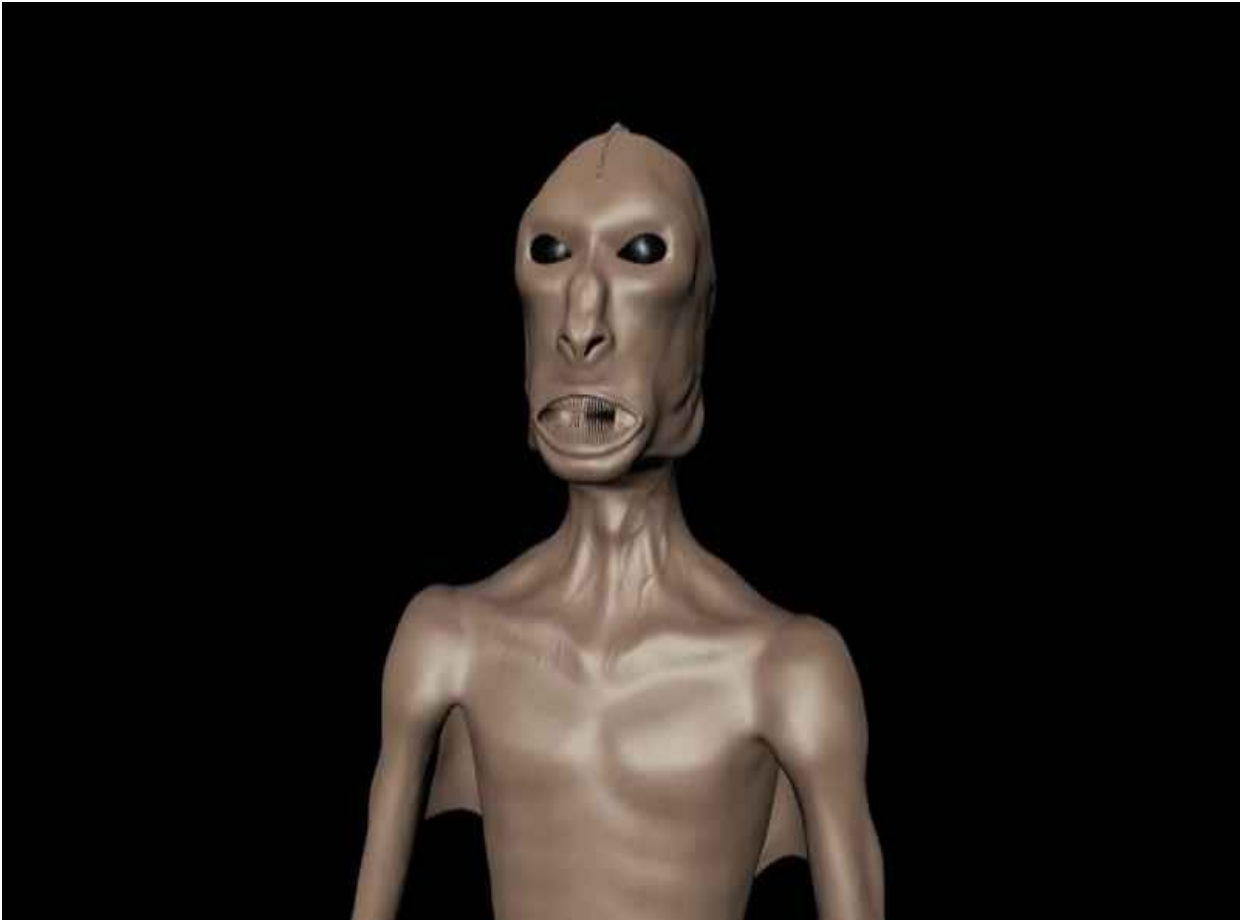

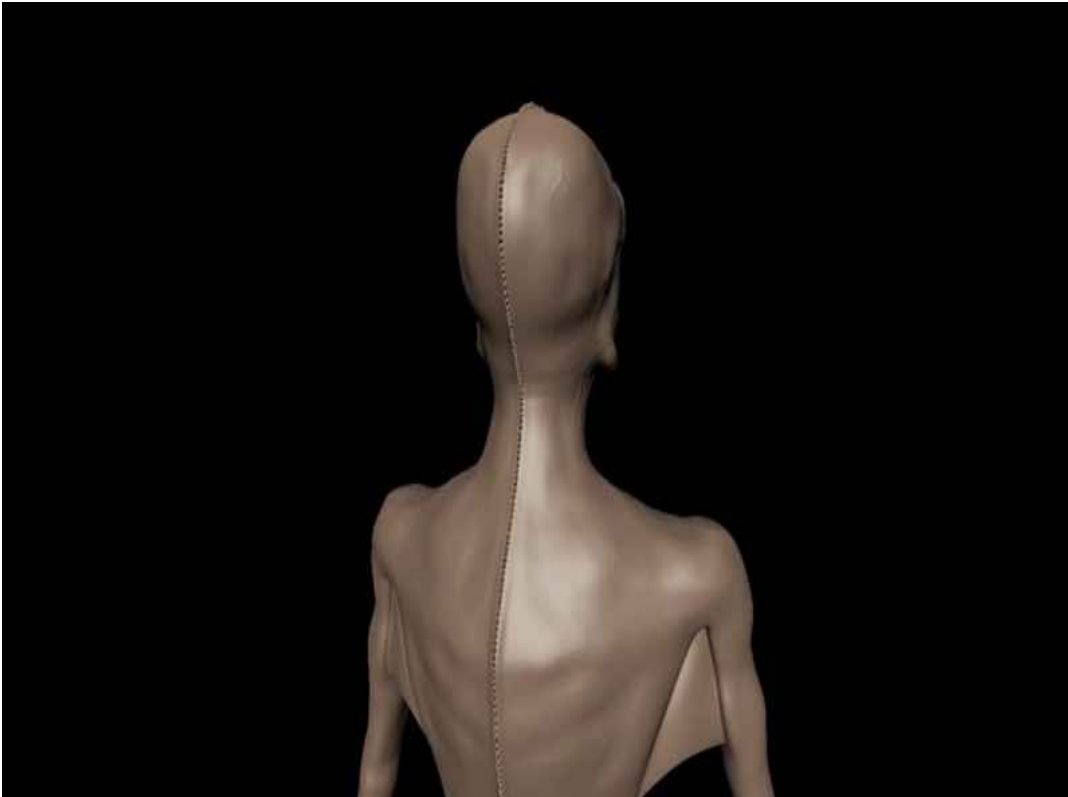

The skull looked sort of like a rhesus monkey-shaped skull.

We jokingly, later on, were calling them “sea monkeys”.

But as its body went down, its ribs were real fine ribs, like in a snake.



And it went down and tapered down until it turned into this long tail that looked sort of like an eel's tail. That's the closest I could relate to something that we've seen on Earth.

David: Now, you mentioned that you had an uncomfortable feeling around this being. Could you be a little more specific about what you felt?

Corey: I felt like terror in the pit of my stomach. And there were a lot of odd-looking beings around. So, not being prejudiced . . . I mean, something actually was not right.

And I leaned over to Gonzales. I said, “Does that aquatic being give you the creeps?”

And he stopped, and he reached in his jacket and pulls out a smart-glass pad.

He sits there, accesses it for a moment and then hands it to me.

And then I take it, and I look at it. And it is a report during the Korean War era of a bomber that was on a routine mission when it had mechanical issues and they had to end up ditching in the ocean.



But the crash-landing was successful, . . .



. . . as the occupants of the plane, which was over a dozen, were able to gather supplies and deploy rafts, and send off a Mayday signal.



So they were just sitting floating in these rafts, waiting to be picked up and rescued.

What they reported next is that they started to separate, so they put out their oars, and they were trying to bring the . . . there were three rafts.

They were trying to bring the three rafts together to help increase their chances of survival.

As they were doing this, they saw a human figure leap out of the water, grab one of the men by their life vest . . .



. . . and pull him into the water.

And then it was out of the water bobbing up and down, trying to pull him under water, but it couldn't because of his life vest.

Right after this occurred, they heard screams coming from the other raft.



And the raft I'm giving you the point of view of is the one of the captain of the plane and his second-command were on this raft.

And once they saw another human figure jump up and grab a person and pull him in the water, they figured that they were under attack from some divers.

So they drew their weapons.

And sure enough, they started leaping out of the water at them.

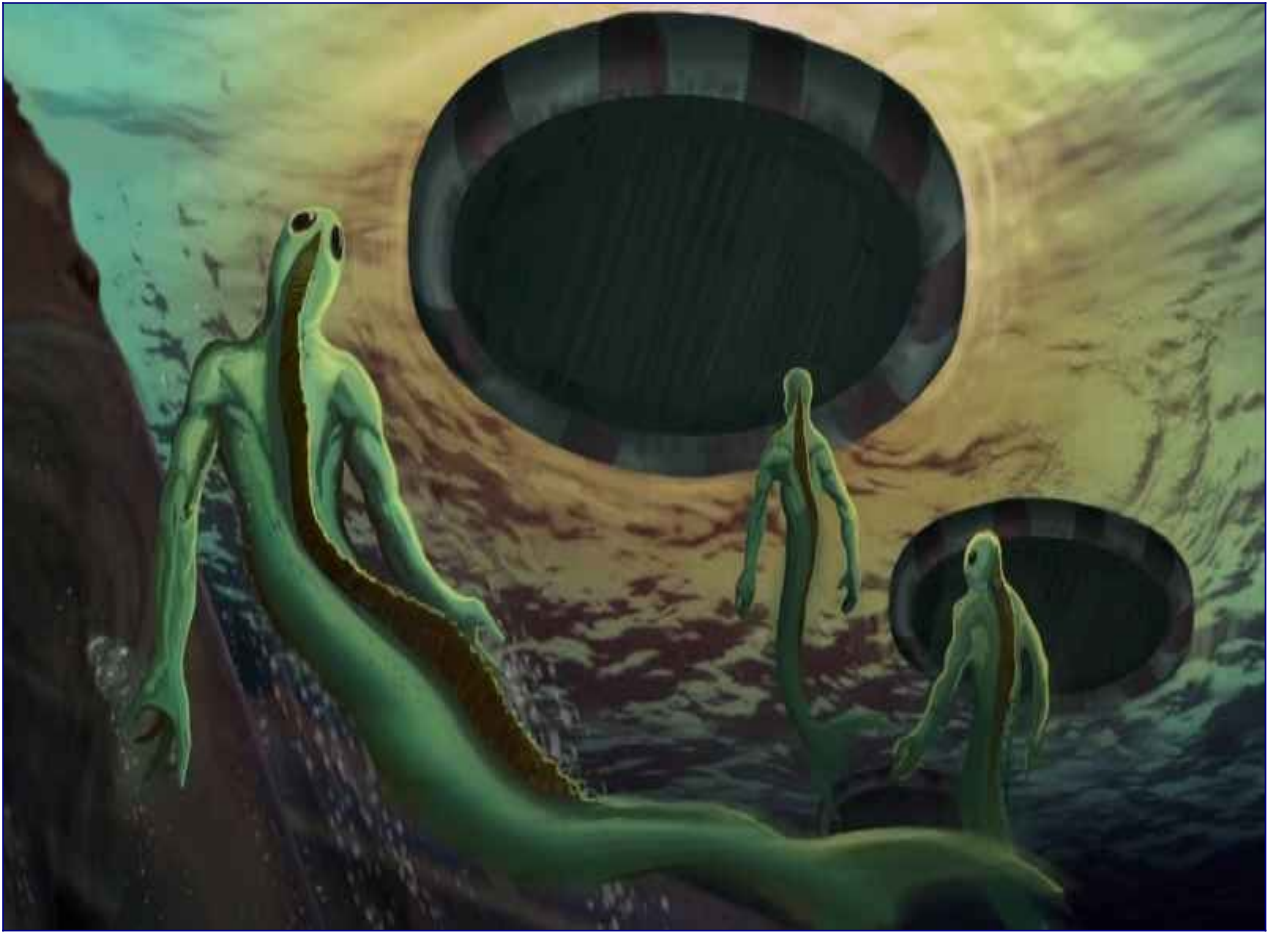

And they opened fire, and they killed three of them.



And they were this being that gave me the creeps – the one with the eel tail.

David: So this would have been very shocking for the soldiers, obviously. They're encountering something that's clearly an intelligent life form, but really nothing like a regular human being at all.

Corey: Yeah, they were sea monsters to these guys, basically.

David: Right.

Corey: So what occurred is that they stayed in back-to-back defense until they were rescued some hours later.

And two of the dead beings were pulled back in the water by their comrades, I guess you would call them. And they [the soldiers] grabbed the shoulders of the other one and pulled it all the way up, so they would have something to show.

And when they were rescued by the Navy, the Navy confiscated the being.

And the final report that went out was that the men were delirious after being in frigid waters all night and after being attacked by sharks.

David: Why do you think these beings would immediately be so evil towards humans if we live here?

Corey: Well, these are aquatic beings. They've grown up in an aquatic environment. They do not . . .

Interfacing with them is very weird, because you get different pictograms from them – a totally different frame of reference from being an aquatic being.

They are here to study aspects of the ocean.

Not only could they care less about us, and what we're doing, they cannot stand us, because they see us as polluting the ocean and not living in balance with the environment.

And we're affecting their program – the program that they're doing under the ocean – their genetic program.

David: And what is that exactly? Do they consider Earth their home?

Corey: No, . . .

David: Do they feel like they belong here?

Corey: . . . but there are so many different types of life developing here.

You know, when I talk about the 22 genetic experiments, I'm just talking about the humans.

There are other things in the ocean that are very important to other beings from other planets. And these aquatic beings are not very happy with the way humans have treated the ocean.

And what I was told is that the last thing you ever wanted to do was accidentally happen upon one of their experiment zones, because if you are, they are going to attack with extreme prejudice. They do not like humans at all.

David: Experiment zone, okay, but what are they experimenting? What is the experiment?

Are they trying to create life there? Are they breeding something in the ocean?

Corey: They're studying and managing the development of aquatic life.

They not only learn about other aquatic life in the universe, but they're able to do genetic experiments and create different types of life that they then study to see how they fare in our environment.

You know, some of them they will give certain abilities to, but where they gain here, they lose here. And they don't survive in our ecosystem very well.

David: Why wouldn't the beings try to work out some kind of a treaty with us or make an agreement of some kind? Why would they just act in a shoot-first, ask-questions-later kind of fashion?

Corey: They've been here doing experiments in the oceans way before we were bipedal – walking around.

David: Hm.

Corey: I'm sure they would much rather have had an aquatic life form become the dominant species on the planet, but that just wasn't the case. It was a mammalian one.

This is a mammalian experiment that mainly was established.

But our oceans are so diverse that they cannot ignore the opportunity to take advantage of that diversity and genetic diversity to create new types of life and to learn more about their own type of life.

David: Did both of these beings have some kind of water around them?

Corey: Yes.

David: Okay. And was it the same kind of invisible cylinder thing?

Corey: Yes. I asked Gonzales about this. Basically, I was asking, "Do we all have that type of atmospheric assistance?"

And he told me, "This station is incredibly ancient and incredibly intuitive and intelligent."

He said the minute you are brought on, I mean, just instantaneously, when you're brought into this ship, no matter where you've come from in the universe, even if they have no idea what your environment is like, a field around you appears that gives you your exact atmospheric and barometric pressure that your body's used to.

David: Hm!

Corey: And it's invisible. No one can see it.

So I was told that every being there was being provided some sort of atmospheric assistance.

David: So obviously, there's something that's building up here. You're seeing these aquatic beings.

And you mentioned that you and Gonzales were in the horseshoe-shaped area.

Corey: Right.

David: Is everybody in the same horseshoe, or did you have some sort of chair that was more prominent?

Corey: No, it was just like all of the others.

David: Okay.

Corey: And the three chairs were empty, and Gonzales stopped in front of the chair. And I looked at the chair, and I said, “So, are you in the chair today, or am I in the chair today?”

Because that's . . . When you sit in there, that's when you're communicating with the rest of the group – like giant telecommunications kind of thing.

David: Right.

Corey: When I asked him that, he kind of smiled, and said, “No, you're up there.” And he pointed up to the circular stage.

David: Hm.

Corey: And immediately, I felt this big lump in my throat. And all the other chairs are facing that one central location.

David: Were you concerned?

Corey: Yes. I had no idea, not only about what was going on, but about what to do.

And he said, “All you really have to do is walk up, stand on that stage, and think to yourself, “I'm ready.”

He cracked a joke. He said, “Don't worry. How could a meeting between the Guardians and the Super Federation be a bad thing?”

David: The Super Federation, you say, is outside of time, but this seems to be a very unusual thing, nonetheless.

Corey: Well, the station is outside of time. These beings don't stay in the station all the time.

David: Okay.

Corey: They're going back to their local galaxy or star system.

David: But it's not normal that they would get to talk to the Guardians, correct?

Corey: No.

David: How often do you think they would have the opportunity to do this?

Corey: I don't know that they EVER have.

David: Really?

Corey: Right.

David: But yet, you're saying that – to go back to some history from our show – that the Asteroid Belt was a planet that blew up half a million years ago.

That allowed these beings to come in here. It took down a protective grid, and it allowed them to start doing genetic experiments here.

So you're saying that they might have had half a million years to do genetic experiments without ever hearing from these Guardians before?

Corey: Yes.

David: Really?

Corey: Right. Not directly.

David: So this is like THE . . .

Corey: Gonzales had delivered a message to them from the Guardians, but they had never been in the presence of the Guardians.

David: Wow! So this would be the first time in an entire half-million-year history that they've been doing this that they would get a direct communication.

Corey: As far as I know.

David: Wow!

How did you know what to do at this point? When you walk out there, like obviously, you don't have any information in your own mind.

Corey: I went up, stepped onto the stage. I made a joke, also. I said, "What, we don't have to wear that stupid purple uniform that they made me wear last time?" They made me dress in this weird purple thing. I don't know why.

David: Okay.

Corey: But we weren't required to wear anything in particular.

I went up, and I stood on the stage. And I looked out, and all eyes were trained on me at that point. And I was extremely nervous.

And I thought to myself, "Let's just get this over with."

And I closed my eyes, and I made fists, and I said, "Okay, I'm ready."

David: Now, these beings know that they're not in charge, right? They might call themselves gods to us, because they're doing all these genetic experiments, and they're appearing as if they were angels or gods.

But they know these Guardians rank higher than them and have some kind of control that they don't have? Would that be correct?

Corey: They're all aware of, yeah, the cosmic pecking order, but most of them had the same attitude of what they're doing was extremely important and shouldn't be interrupted.

David: Okay. Within the actual Earth part of this meeting, did you see anyone familiar?

Corey: Yes. When I was looking out, I saw the Earth delegation seat that I had sat in last time, and I recognized one of the Council of 200 members that I had dealt with sitting there with a scowl on his face.

David: Is this someone that would be recognizable to most people on Earth?

Corey: Yes.

David: Interesting. So he didn't seem too happy about whatever was going on.

Corey: No.

David: You step out there, and then what happens?

Corey: Much like when I was at the Lunar Operation Command, suddenly Teir-Eir and the Golden Triangle being appeared behind me. Very much the same thing happened.



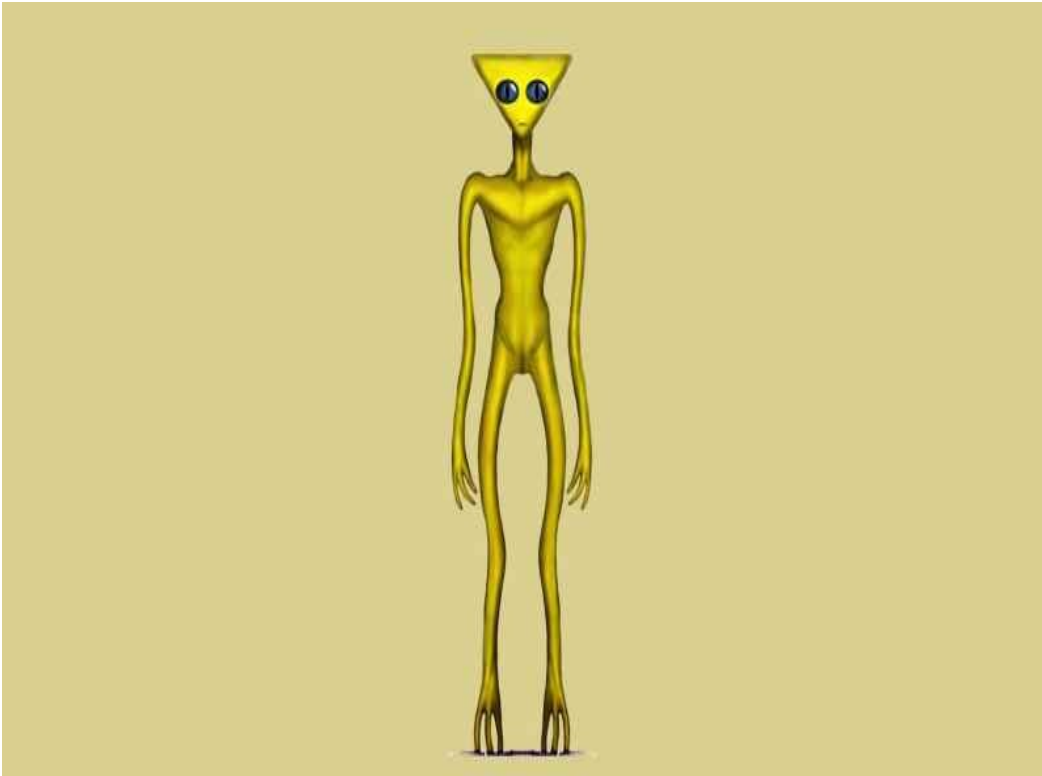

And it got very quiet. And I turned and looked up at Teir-Eir, and he began moving his hand. And he told me, “Repeat everything I say, exactly as I say it.”



David: And this includes verbal delivery, intonation, that kind of thing?

Corey: Just the verbal part.

David: Oh.

Corey: I didn't have to move my arms around like he was doing.

David: Okay. So he tells you this, and then what happens?

Corey: Immediately, I begin to speak. The information is . . . I hear it in my mind, and then it, with almost no effort on my part, it goes down to my mouth and came out.

David: Were you aware of any of the content?

Corey: I was aware of a lot of the content. Some of it was over my head. I didn't understand it. But some of the content was blocked from me later on by the station. The station blocked . . .

Teir-Eir had me addressing some of these beings by name, and I can't recall the name.

And some of the beings . . . I remember seeing their faces when I'm there, but now, when I'm trying to recall what they look like, it's similar to what I've described in the past. It's like they have no face. It's just skin stretched across – no face.

David: Interesting. So what was the gist of the message that starts to unfold from what you were allowed to remember or authorized to remember?

Corey: Well, the gist of it was that Teir-Eir told the Super Federation that they would soon disband; that these 22 genetic programs were coming to an end; that humanity has a lot to overcome, but it is now our moment – our time.

The 22 genetic programs . . . They've been tinkering with our genetics AND our spirituality for many millennia.

And what the message that was delivered to them was: that humanity, now that they are a starfaring race, would now begin to manage our own genetics and our own spirituality; that we weren't going to have these beings managing us and us having to report to them.

David: What was the first thing that they said? Do you remember what the first greeting was?

Corey: They always greet you, “In the love and the light of the One Infinite Creator”.

But something that they said this time that was new was that they said, “In service to all; in service of the One.”

David: Hm.

Corey: They said that at the end before they left.

David: And before we get to the reaction, could you tell us a little bit about: what does this telepathic interaction feel like to you?

What kind of, if any, are you . . . Are you just flat and emotionless, or are you feeling something? What are you actually . . .

Corey: Oh, the opposite. I had tears running down my face. I mean, just . . .

And that happens often when I'm dealing with the . . .

When they're communicating with me, I'm getting not only pictures and words, but I'm getting sounds. I'm getting smells. And it is so overwhelming that emotionally, sometimes you basically bawl like a baby. You'll just have tears running down your face. It's just emotionally overwhelming.

David: I'm curious if there was a loving feeling. Do you feel some kind of blissful love as well?

Corey: Yes. Yes. It was a loving feeling, but it was also more of business.

They were there to discuss business. They weren't there to have a two-way conversation. They were there to deliver some information and then leave.

And that's exactly what they did.

David: So we're literally talking about all these different beings that have been using the Earth as a science lab, a genetics lab, a spiritual-experimentation research center for half a million years. What's the reaction going to be if they're told they've got to pack up and get the heck out of here?

Corey: There was a HUGE reaction. And some of them were kind of yelling out telepathically.

Don't ask me to explain that.

And others were verbally speaking out and shaking their fists.

And the station took over. And people, the ones that were talking, they were moving their lips but nothing was happening. So it was sort of like something that took over.

Now, there were people there, beings there, that seemed very happy about the situation.

David: Hm! Some of the Super Federation beings.

Corey: Yes. And Teir-Eir had me basically tell them that there was going to be a restructuring of the Super Federation: that the majority of them were going to be disbanded, removed. And a small number of them were going to work in concert with representatives from our local 52 stars, our cosmic cousins.

They were all going to form this Super Federation, and we're going to have a permanent seat.

David: Hm.

Corey: And that is a REALLY, REALLY big deal.

David: I know you've said before that we were not allowed to have an actual seat on the Super Federation. We didn't even have the ability to directly govern it.

That would imply, then, that this was something more that those people decided amongst themselves, rather than some cosmic law that they were told they had to follow.

This is like they're getting a decree now. Would you agree with that?

Corey: Well, it is all a part of cosmic law though. As the energetics change and humans begin to have more control over the genetic and the spiritual part of their experiment, then these other beings are pulled out of the situation.

This has occurred in star system after star system. They've been pulled many times out.

They became so upset that Teir-Eir had me tell them, "Remember the Ponce System", which I have no idea what that means. But they all got very quiet and less animated at that point.

And I got a picture in my head. I saw Super Federation and Guardian assets in a war of some sort.

David: Hm.

Corey: But that's all the information I really could glean.

David: Okay. Well, we're just about out of time in this episode, so can we quickly cover anything that happened in this that you haven't already gotten through?

Corey: Well, once the meeting was over, the energy in the room came up. I mean, everyone was excited or the opposite of that.

And Gonzales ushered me out really quickly. He's like . . . get me out of the room before I got mobbed.

And as he was walking me out, he spun me around, and he said, "Do you know what this means?"

And I looked at him and I said, "We are not going to have a bunch of aliens pretending to be our gods?" basically is what I said.

And he looked at me and said, "They ARE the gods from our myths." He said, "But yes, that means that humanity is now in control of our own future genetically and spiritually." He was very excited.

He escorted me back to that area where I was dropped off. And I was picked up by a Blue Sphere, and off I went.

David: What does this really mean for humanity, for our future, with the Cabal, and with what they've been doing?

How does this all manifest as the future that we're going to see as real people here on Earth?

Corey: Well, I mean, basically, it was communicated that they were going to make it energetically impossible for the Draco to exist in our space.

David: Oh, wow!

Corey: Not only are they going to do it, but it's a part of this natural process that happens in the cosmos as the energy increases in this part of the galaxy as we rotate around the galaxy.

What occurs is that, as a natural process of what's occurring with energies traveling through the cosmic web, as the galaxy is rotating into a more energetic area of the galaxy . . . Remember, the cosmic web is made up of every star in our universe.

David: Okay.

Corey: Each star is connected by an electromagnetic filament tube.

David: Okay.

Corey: And it is through those tube connections that the portal system works. That's how the portals work. They go from star to star.

David: Okay.

Corey: As other stars in our local star cluster are moving through this energetic part of space, energy feeds in to the star. It goes in through the north and south poles. And some of it feeds out through that star.

And the residual energy feeds back through that cosmic web microtubule connection to OUR star.

Our star is going through something similar. And what occurs is for 1,000 years, as we go through this orbit and it loses that electrical connection, we have an energy that builds up in our Solar System that is not compatible with the Reptilians.

David: Hm.

Corey: It is like poison.

David: If they can't escape anyway because of the Outer Barrier, then would any of them survive this at all? Is there any way that they could survive this?

Corey: They can now travel through the Stargate System, but all of that is heavily monitored. They know how many hops you've taken. They know exactly where to find you.

What occurs is that, much like the Anshar created this time-space bubble that they put their city inside of, the same thing occurs with a lot of these Reptilians – the Draco and the insectoids. They form these pockets in time-space that they go inside of and wait out the energetic changes.

They're also in bases that are heavily shielded deep in the Earth.

So they're going to try to wait out this thousand years and then come back out and rule again.

What's going to keep them weak and in hiding . . . And humanity is going to be responsible for going down into the bowels of the Earth, finding these zones, and cleaning them out of the Reptilians.

In a conversation with Gonzales, he communicated that supergates are something special. And there's one just outside of our star system.

It is against cosmic law for any species to be banned from a supergate.

David: Hm!

Corey: Now, they can't ban the Reptilians from the supergate, but what they can do is poison the well in our star system to where they can't come into our Solar System anymore.

They will be coming and going from the supergate, but they will not have access here for a thousand years.

And when Gonzales said that, I had a weird look on my face. And he said, “Sounds biblical, doesn't it?”

David: Hm. Is the Galactic Federation involved somehow in poisoning the well for the Draco?

Corey: The Guardians are the ones that manage these energies. And they will help manage these energies, but they're not doing it to keep the Draco out. They're doing it as a natural part of cosmic progression.

David: It is interesting, **Corey**, to note that in “The Law of One” material, they talk extensively about Ascension. And they use the metaphor or term “harvest”, which, as I've described in “Wisdom Teachings”, shows up in the New Testament a lot.

So they use the metaphor of us being like fruit that has to . . . The whole tree has to ripen, if you will.

And then they say that these Guardians show up to make sure that “the fruit is harvested without bruise or blemish.”

So do you think that what happened in this meeting has something to do with them making sure that we are not blemished as we go through this Ascension process?

Corey: It sounded like in the past, when the Super Federation had reached that natural point to where they were supposed to leave, at times, they had refused to leave.

David: Hm.

Corey: And there had been conflict because of it. So it's a natural part of the cosmic law and cosmic progression for these beings to be reminded that it's time for them to move on to their next experiment.

David: Well, that's really, really amazing and very good news.

So, **Corey**, I want to thank you for bringing this to our attention and being that messenger. And I want to thank you for watching. This is “[Cosmic Disclosure](#)” with your host, [David Wilcock](#) and **Corey Goode**.

[Cosmic Disclosure: The Anshar and Red-Headed Giants](#)

Season 10, Episode 3

[David Wilcock](#): Welcome back to “[Cosmic Disclosure](#)”. I'm your host, [David Wilcock](#). I'm here with **Corey Goode**.

And where we last left off, he had had a very interesting meeting with the Super Federation, and I guess you thought you were going to go home.

Corey Goode: I did, yes.

David: But that isn't what happened, was it?

Corey: No. No. Right after this meeting, I ended up in the foyer of the Super Federation base, and it was at that point where I was picked up by a Blue Sphere I thought to bring me home.

But instead, I ended up in that huge domed area of the Anshar temple complex where I had first appeared well over a year ago when I first met the Anshar.

I appeared there. There was . . . It was bustling.

There were people in line to go into this one opening that went in towards the cleansing ceremony, and I immediately saw Aree and her sister walking towards me with huge grins on their faces.

David: **Corey**, you are now calling her Aree, and you've also mentioned her sister, so could you please clarify why the name change, and who is her sister exactly?

Corey: Aree . . . She's had me call her that from the beginning. I was continuing to use her full name: Ka'Aree.

Ka . . . She comes from the House of Ka, apparently, her and her sister.

I was doing that to be able to tell who was genuine in saying that they had been in communication with the Anshar.

David: It is interesting to point out that in The Law of One Material, they specifically mention the Ka as a name for the spiritual body that we all have.

Corey: Hm.

David: So that is a direct Law of One reference, interestingly enough.

Corey: Yes.

David: So who is her sister exactly? Can you tell us a little bit about that?

Corey: Yeah. Her sister is very similar to her in just about every way. I'm keeping her name to myself for now.

She's doing a lot of outreach to people right now on the surface.

David: What specific types of outreach would you say that her sister is doing?

Corey: Well, she's one of the people that are sitting in these egg-shaped chairs, that I've described before, that are networked together between their mass consciousness and ours. They reach out to us in dreams.

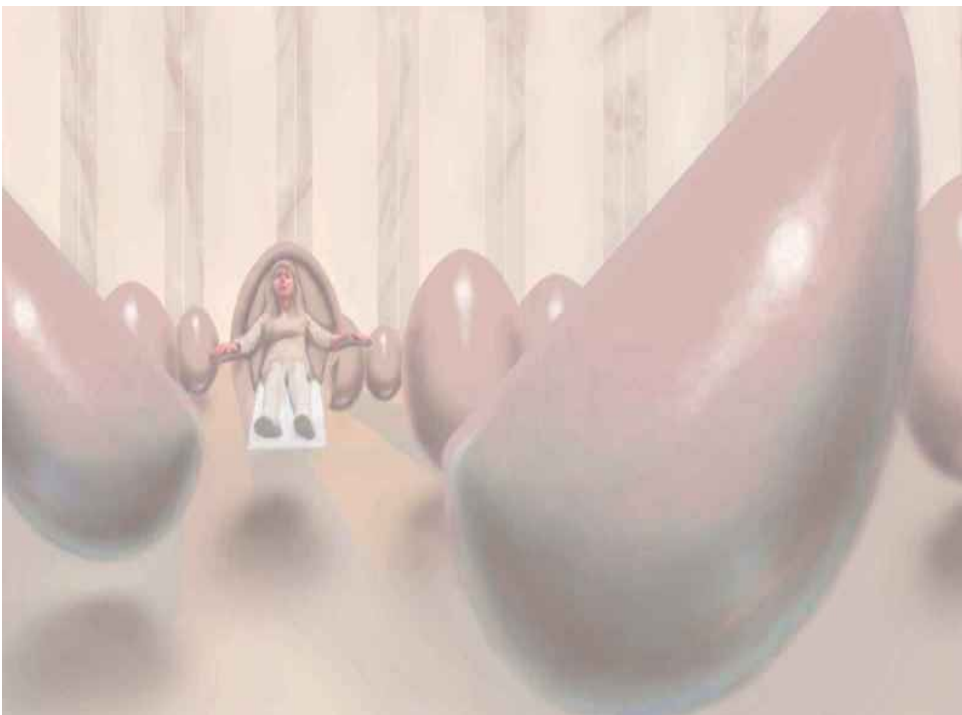

Later on, I get to learn how to use these chairs a little bit more on my visit, and it's also somewhat of an entertainment for them. But they watch us, observe us, and give us guidance remotely from these chairs.

David: Normally, if people have things appearing in their mind, we would call that schizophrenia or something along these lines.

So what is the dividing line between this guidance and a profound mental illness of somebody “hearing voices”?

Corey: Usually they're not speaking to people in voices. What they're doing is . . . I'll just go ahead and describe:

When you're in one of these chairs, you can use it to go to any gathering, or place where there's just one person, and be in the room with them.

You are basically above their shoulders and head looking down on the scene, almost like what people would picture angels doing.

They sit there, and they observe conversations or observe a person working, and if they think, “Oh, I could guide them in this way. This would make this much difference in the timeline and help here and here,” then they do this kind of a “bling” [a sound], where they give the person a download, and it's like an information package that's compressed.

And then it decompresses, and people just get all of this flood of ideas, and we call them “downloads”.

David: And it appears as original thought without the people realizing where it came from.

Corey: Exactly.

David: Okay. So you meet Aree and her sister. Could you tell us what happens then? You said they're really smiling. Did you know why?

Corey: Oh, yeah. It was because of the meeting I had just been at. They were very excited about it.

David: So what happens next at this point?

Corey: They immediately guide me to the corridor that leads out to that huge cavern where the Anshar city used to be.



If you remember, the city was somehow removed and put into this temporal anomaly.



David: Right.

Corey: There was one of the Anshar bus craft waiting for us.

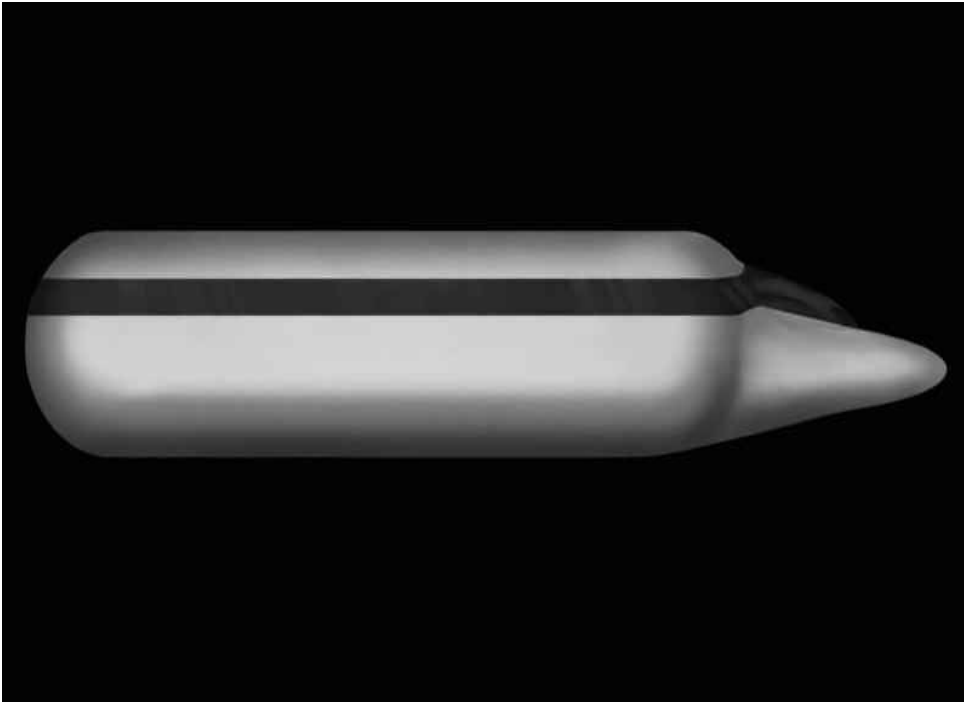

People were boarding it, and Anshar were boarding it, and there were already Anshar on board sitting.

David: About how many were in the craft?

Corey: More than 15.

David: Okay. So it's pretty crowded.

Corey: We take off, and then we head right into that temporal anomaly.

David: What does it look like as you go into it? What do you see?

Corey: Well, I didn't get to see anything . . .

David: Oh.

Corey: . . . because it's like someone turned on this huge magnet next to my head, and my consciousness does this . . . I mean, I kind of pass out and fall to the side, and then I come right to immediately once we get through it.

It's like just some sort of barrier that affects my consciousness.

David: Hm.

Corey: You can see all the cities laid out all along the sphere. The tops of the buildings are facing towards the center point in the sphere.

David: What do you mean by “the sphere”? Is it a sphere of energy? Is it a cavern?

Corey: It's a spherical energetic bubble.

David: Oh. Okay.

Corey: And along the inside of the sphere is where all of the cities have been joined together.



David: Okay.

Corey: So we fly down into the Anshar city area, and we approach some of the huge domed buildings.

And we land on top of one of them on this . . . it's almost like a helicopter pad, but it's larger.

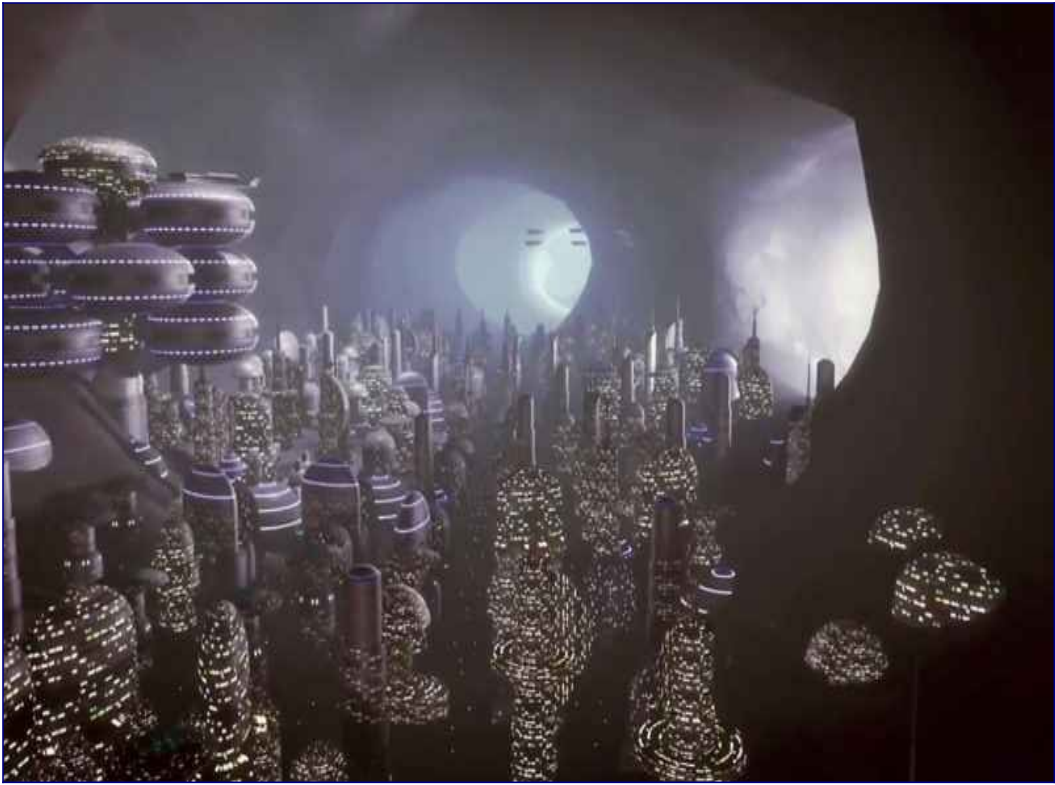

It's on top of the building kind of on stilts.

So we disembark from the craft, and we all start heading to this area on the roof that was an area that you walk in, and then there were two oval holes in the floor that are sunk into the wall that go down like tubes.

And each of them began to walk up and stand in those tubes and go down.

As we got closer and closer, it was my turn. I thought it was going to be like a slide you jump in and phew, down you go, but I stood, and there was like a barrier that moved a little bit when I stood on it, and when I looked down, I saw the Anshar that went before me looking up at me.

I saw this part of their face and forehead [*Corey motions to the left side of his head*] as they kind of disappeared. And then I went down.

It was just like riding an elevator.

David: Did you get any fear of heights or anything just to walk into a hole?

Corey: Yeah. I had an uneasy feeling. Like I said, I thought I was going to . . . I had the feeling . . . My brain was telling me that I was just going to drop.

David: So what happens as you go through this tube, and where do you end up at the bottom?

Corey: Well, we end up at the bottom, and we walk out, and there's this huge area inside the dome where Anshar are walking around all over the place.

They are wearing all kinds of colorful clothing that is obviously woven. It wasn't this high-tech type of clothing that I had seen prior.

Anyway, we're walking through this group of people, all bustling about, going on their way to do whatever they were doing, and we see some of the people walking out, and some of the people coming in, but it's through like a wall. It looked like people were just walking through the wall.

David: Wow!

Corey: We walked through, and there was a little sticking, kind of a stickiness energy, as we walked through, but we walked through, and we were in a bustling area of people walking around, people flying around like Superman.

David: Really?

Corey: The elders, the people who were much older, will fly around using the technology that they have to fly around like Superman. But everyone else was walking around like we would at a mall.

David: Well, now is it a technology, or is it like telekinesis? Is it some kind of psychic ability they have to do that?

Corey: It's a technology.

David: Really? Well, it must have been impressive to see, I would imagine.

Corey: Yeah, it was, because you would see people coming down and lifting . . . just, I mean, like Superman.

David: Why do you think only the elders were able to do this or allowed to do this or something?

Corey: The elders . . . they looked different than the rest of the Anshar.

I was told that it's not uncommon for fourth density and other types of beings as they age, they get taller and skinnier, and this, apparently, is what happens with them. They grow another two or so feet, and they get very, very thin, very frail, and their skin gets even whiter. And they had wrinkles all around their lips and around their eyes.

David: I want to point out something so bizarre, which is: I had this call from **Pete** Peterson where he starts telling me about these Nordics that he had encountered when he was in there, and he said exactly the same thing, that they go through three growth phases.

The third growth phase causes them to get taller and skinnier.

Corey: Another thing that I saw that they wore is they wear an eye protection. Their eyes get very sensitive.

We walked to a building that was a building for Aree's family group and the offshoots of her family group. They were all together in this big building.

I was brought to the area where her family group lives, and I was shown a room, a small room, that had been set up for me to sleep in. I was going to be there for a while.

David: Wow.

Corey: She brought me to the bed that was created for me, because they don't use beds.

David: Well, hold on a minute. They don't use beds why? What do they do instead of sleeping?

Corey: They do some type of cycle that lasts like 45 or 50 minutes ever several days. They don't have a sleep cycle.

David: They don't need to lie down when they do that cycle?

Corey: No. They sit in the chairs.

David: Okay.

Corey: So on this bed, the first thing I see are three shirts, three pairs of khaki slacks, and a bunch of toiletries, just strewn out.

The clothes look like they were from like JCPenney's in the 1980s. It was blue, just regular, blue polo shirts and khaki pants, no belt, and they had underwear, deodorant.

So I saw all of this, and I realized they were going to have me there a little bit longer than they ever had before.

David: Wow!

Corey: And sure enough, I ended up doing two sleep cycles when I was there, two full sleep cycles, so I was there probably about three days.

David: Was this the size of like a small dormitory room, or did it have some space to it? What was your room like?

Corey: No, it was very small. It was probably eight feet by six feet.

David: Oh, wow!

Corey: But, I mean, I wouldn't spend much time in there.

David: Obviously, you're going to need to eat something. So what was the food that they provided?

Corey: The food was all vegetarian, of course, a lot of raw vegetables, and a lot of interesting sweet cakes that they made out of vegetables that were really good.

David: Would you say it's the best stuff you've ever tasted in your life, or was it just okay?

Corey: To be honest, it was kind of bland.

David: Really?

Corey: Yeah. It was just . . . I mean, there was no seasoning. They were just eating raw vegetables, and they didn't eat that much, and they didn't eat that often.

David: Did you get the sense that you were being fed the same things that they were . . .

Corey: Yeah.

David: . . . or did they have to modify it?

Corey: No. I was sitting, eating along with them.

David: Where you were sitting, did it look at all familiar to what we would have as like a cafeteria table or something?

Corey: Yeah. It was a cafeteria.

David: Really?

Corey: Right. They had a commons area, a large commons area. The roof was higher. It was about two stories high. And then they had private areas where they had private . . . areas where they could have their own . . . kind of like a room, but they didn't really spend much time in them.

David: So if you need to eat more often than they do, would they bring you to this cafeteria and then not have food, or would they always eat with you?

Corey: I only ate three times.

David: Really?

Corey: Yeah. But, I mean, you've seen how I am anyway since I went over to being a vegetarian. I ate one, maybe two very small meals a day, very small.

The food was very high in nutrients, obviously, because, I mean, you immediately felt a pickup from the food . . .

David: Wow!

Corey: . . . when you ate it.

David: So it was energized somehow?

Corey: Yeah, but it tasted like normal vegetables.

David: At some point, you're going to have to be asking yourself: "They bring me into this bedroom. They give me these weird, old clothes."

I would imagine you would be turning to them and saying, "Guys, I thought I was going home. What's going on here? Why do I have to be here long enough to sleep over? What's your agenda here? What's happening to me?"

Corey: Well, Aree told me that I was being given a gift basically, that I was being allowed to spend time with her family group, and also go through the preparations to go with them to this base outside of Saturn to meet this "Council at Saturn", as they call them.

So, you know, I got to spend a lot of time with these people.

I was told not to touch anyone – to keep my distance.

David: Which is exactly what **Pete** Peterson said too, interestingly.

Corey: Right. When I first arrived, they stood a good distance away and weren't being that friendly, but they saw Aree . . . When I first got there, she took me by the arm, touched me and took me by the arm and guided me to show me where I was going to be staying.

After that, it had an impact on the people. They started getting closer and closer, started asking me questions, talking to me. They were very curious about the surface world.

David: Let me just ask you one thing that might clear some misunderstandings up for our audience.

People might be inclined to think that these beings are interdimensional, and that, therefore, they would be like ghosts to us, and, therefore, if you were going to go there, that you would have to be like a ghost.

Corey: These are not higher dimensional or different dimensional beings. These are us from the future.

They traveled back into time to preserve their timeline. They are flesh and blood just like us.

So after the first day, the children and the other people started coming closer and closer in, spending time with me, close enough to where I could touch them, but I didn't.

At some point, there was kind of a parting of the waves, people were getting out of the way, and I look up across the room, and there's Gonzales. He looks very haggard. He looks beat.

He sees me, and he starts to walk across, and I meet him, and he just drops into one of the chairs.

I go over to one of the chairs, and I sit in it, and I mentally guide it over, the way they showed me how to do, over next to him, and asked him, what are you doing here? What's going on?

David: So you can steer the chair around just with your thought and move it to different areas?

Corey: Easily.

David: So you zip over to Gonzales's chair, and then what happens?

Corey: If you remember, Gonzales got to spend a lot of time with the Anshar. He was actually staying with them in their city at one point.

David: Right.

Corey: And as a part of the work he was doing while there, he was working with this race of giants, a red-haired, six-fingered race of giants.



He was starting to make some headway with them when he was basically kicked out by the Anshar for his behavior.

David: Now, we have enormous numbers of records of giant skeletons that have been found all over the Earth. Are those red-haired giants related to them somehow?

Corey: They are.

David: In what way?

Corey: Well, let me just go ahead and tell you what occurred.

David: Okay.

Corey: Gonzales said that for the better part of a year, if not more, he's been working with the red-haired giants. He'd been trying to get them to accept some of the healing technologies from the Mayans.

However, they have been refusing any type of help from the Mayans, thinking it was some sort of leverage for them to say that . . .

[The] Secret Space Program Alliance and the Mayans have, at times, rescued red-haired giants from various places on the planet and brought them to this sanctuary.

“We don't want the healing until you can get our royal family, basically, that's being held by the Cabal in a base.”

David: Okay. Well, there's kind of a lot of questions that that raises.

Corey: Yeah, and it doesn't make sense for them to make a demand like that.

David: I was under the impression that the red-haired giants died off completely. There's none of them on the surface of the Earth now.

Corey: There are none of them on the surface of the Earth now.

David: So then why are we talking about them as if they still exist? That's the part I . . .

Corey: Because they do.

David: Okay.

Corey: At one point, they controlled a huge area of North and Central America. These beings are genetic creations of this Pre-Adamite race, . . .

David: Right.

Corey: . . . you know, that was in Antarctica. They created these giants to manage humans, their slave population of humans.

After the cataclysm occurred, and the Pre-Adamites were basically wiped off the face of the Earth, or so we thought, these giants had to fend for themselves.

And during this time, they were eating humans. They were causing a lot of problems.

After a number of years after this cataclysm, when humans started to organize again, they started going out in hunting parties and killing off these giants.

So the giants had to go underground, and they went deep, deep into the bowels of the Earth into some of these ecosystems deep in the ground that we've told you about, or that we've talked about on [“Cosmic Disclosure”](#) before.

David: So what we're then seeing is: We have American Indian tribes going after the red-haired giants. We have people in Europe and Asia going after the giants, and they retreated to underground areas?

Corey: Caverns with ecosystems.

David: Okay.

Corey: Their health suffered because they didn't have the nutrients they needed, the sunlight. They were eating what was down there, and it was affecting their health not in a positive way. They were getting thinner and thinner.

They hunted one species, a humanoid species, that lived in the Inner Earth, into extinction, because they became very fond of the taste of them, and they wreaked havoc on a few other of the beings that were down . . .

David: Would they look just like one of us only larger, or is there something unusual about the shape of their face or their head?

Corey: Yeah, they have big foreheads, big thick jaws, double rows of teeth. They would not fit in and look like just a large human.

David: So even if you shrank them down to our size, they'd look very, very different?

Corey: Right.

David: Interesting. So they live in these underground areas. They're essentially wiping out other underground populations of humanoids you're saying.

Corey: Right. Well, what finally ended up happening in their history is that some of their royal caste helped them start to get it together, as they say.

They were a mess when they were refugees under the ground. So they found areas that would sustain a small population. They controlled their number, their population numbers, and some of the royal caste and religious caste of these giants went to various stasis chambers and put themselves into stasis.

David: I'm just curious now about when we look at the records of their civilization in the Americas, we find the so-called "mound builders", and there's always these dirt mounds that are kind of pyramid-shaped.

People would dig into the mounds, and they'd find giant skeletons inside. So the giant skeletons and the mounds are always one in the same thing.

So it seems that these people had some desire to keep building pyramids. Why do you think that is?

Corey: Well, the giants were the ones that were supposedly directing humans, or controlling humans, when they were building out the infrastructure and cities for the Pre-Adamites.

So maybe, I'm speculating, these giants were, I guess, the foreman on these jobs, and they were making sure that the human slaves were completing the jobs.

David: The mounds that people dug into, we never really saw any type of written books or . . . How literate do you think they were? Did the flood affect them so badly that they . . .

Corey: Yes.

David: . . . lost a lot of their language?

Corey: They lost everything.

David: Really?

Corey: Right. They were in the same boat as the humans. Everything was lost. So . . .

David: Then how would they know about these caverns under the ground if they're essentially now illiterate?

Corey: Well, they were forced down in. They were forced to go in and explore and find these areas.

David: Okay.

Corey: What finally happened is they got their people together, the giants, and they said, "Okay, we have these little pockets of areas that will sustain this number. So maintain these numbers. We're going to go into stasis, and when we pop out, that way we will be as strong and as powerful as we are now.

"And when we pop out during the time of these great energetic changes, we will be more useful."

But what happened is . . . There was over 130 of these beings spread out in these stasis chambers. And mostly what has happened is the Cabal has located these stasis chambers, awakened the giants, and then moved them to prisons inside bases.

David: Well, I thought you said before that when people tried to access these stasis chambers that they would get stuck, and they wouldn't be able to move through. There was like a gravitational field.

So how could the Cabal actually awaken anyone? I thought nobody could get in there.

Corey: Well, they CAN'T get in, but they have harmonic ways of turning off and controlling that technology.

David: Oh, really? Interesting.

Corey: They found enough of them, broken and working . . . They know how they work very well. They know the mechanics of them.

These sanctuaries . . . The people had survived physically, but mentally, they were completely checked out, these giants.

He said, surprisingly, he was able to relate with them and had more headway with them before he went through his transformation, because they were so psychologically messed up and traumatized that he can't reason with them hardly.

Now - and he was telling me this as he was in the chair – he said, now, after he's gone through this transformation from what he was before, that they just will not relate with him at all.

David: So let me see if I got this. They go to sleep. They think they're going to wake up and be kings over their people, 130 of these you said, but they wake up and now they're prisoners.

So that's got to be very jarring for them, I would think.

Corey: Yes.

David: Do they experience it just like they knitted together two points in time, or do they feel like they were gone for a really long time?

Corey: The ones that were in stasis, it's just like they went to sleep and woke up.

David: Wow! So this sudden loss of power you're saying has caused them to be very, very distraught.

Corey: Well, those are the ones that were in stasis. The ones that were living generation to generation in these ecosystems deep in the Earth, they were the ones that were the most traumatized.

David: Oh.

Corey: Gonzales said that he was just unable to relate with them. He kept saying, “We can help you. We can bring you these healing technologies.”

They're like, “No! First, you bring us our royal families and others” who are in, basically, prison, Cabal prisons, “then we will accept the healing”.

You know, that makes no sense whatsoever, but they are just gone up there.

David: The people that are living inside the Earth that have been there the whole time, do they have any awareness of what our civilization is like on the surface, or are they so cut off that they really have no idea who we are when we would come in and capture them, basically?

Corey: Most of them are cut off, but some of them would do recon missions up to the surface from time to time and have encounters with usually human military.

David: Hm.

Corey: So they had an idea of how out of control they were now.

David: Did they have any communications systems that allowed them to be able to talk to different groups in different areas?

Corey: I was told that they were utilizing some ancient technology below ground that allowed them to communicate here and there.

But Gonzales was really frustrated. He kind of got a twinkle in his eye when he told me that these giants were not relating with him anymore after his change.

And he looked at me, and he said, “How would you like to go down there?”

And I was like, “Ah, not my job, buddy. That's your job.”

David: Go down to where these giants are?

Corey: Right. He said, “Come on, this would not be the first time you had a meeting with someone that wanted to eat you.”

David: Where were these sites? Did you get any specific information about where were these underground sites that they had relocated to?

Corey: Yeah. It was in the Anshar area. As a matter of fact, Gonzales found out about them because the Anshar were being secretive and going off into this cavern area where there was a solid wall they were walking through, and he found a way, after weeks, to scurry around and find a little hole that he could peek through to see where they were going to.

He saw the Anshar meeting with red-haired giants that were just moaning and crying and sounded horrible.

It was soon after that, that he was, I guess, read in and started to meet with them before the Anshar kicked him out.

David: So we are essentially out of time for this episode, but I'm interested just to get your speculation as to how these giants fit into the overall picture of Ascension and us transforming into beings like the Anshar.

What do you think is the reason why you're being shown this stuff?

Corey: The reason I think it's occurring is that these beings, even though they're created and they did evil things, karmically we're all connected.

And just like the Blue Avians were wanting to move to the next octave, but they couldn't because we were acting like a parachute, because they had karmic ties to us, that's kind of the same thing going on with all these other beings.

We all kind of lift each other up and move together, or no one does.

David: At some point, you and Gonzales must have finished this conversation about the giants. So what happened next?

Corey: Aree and her sister visited with Gonzales and I for a while. And some of the Anshar gathered around us . . . were keeping a little bit more distance from Gonzales than they were from me at this point.

At this point, Aree's sister said, "It's time for us to prepare for meeting the new Guardians. And everyone was very excited.

So we started winding down the conversation. Some of the elders invited me to come back and stay for a longer period of time . . . later, months from now.

David: What did they call you when this was going on?

Corey: They called me the Hanush.

David: Really?

Corey: Yes.

David: Okay.

Corey: Everyone kind of got together in the commons area to say goodbye.

And we said “Goodbye”. We followed the same route back to get onto the Anshar craft on top of the domed building, and then we flew out of the anomaly.

David: Hm. Did anything else happen before you actually went home?

Corey: Yes. I didn't actually get to go home . . .

David: Oh!

Corey: . . . still. We landed the Anshar bus craft, walked back into the temple complex, and, again, there were even more lines of people heading into the tunnel system that led back to where the cleansing room is that I described before.

Aree and her sister walked me and Gonzales past the line. We walked past everyone, walked up to the front, and we did the cleansing ceremony.



I folded my clothes, and I was going to put them next to Gonzales's on this pedestal that was in a half moon, semi-circle configuration in that room, in the cleansing room, but Aree had a satchel over her shoulder, a light brown satchel, and she opened it up and held it out for me and indicated that I should put my clothes in there.

I was looking around, and I saw representatives from all seven of the Inner Earth groups that I had met the first time I was there.

David: Now, did they wear the same kind of amulets as when you first saw them?

Corey: Yes. They were wearing the amulets and white tunics.

David: Interesting. Well, that's all the time we have in this episode. I want to thank you, **Corey**. It's very fascinating information. And I want to thank you for watching.

This is "[Cosmic Disclosure](#)". I'm your host, [David Wilcock](#), here with **Corey Goode**.

Cosmic Disclosure: Alien Tech at the Vatican

Season 10, Episode 4

David Wilcock: Welcome back to "[Cosmic Disclosure](#)". I'm your host, [David Wilcock](#). And here again with me is **Emery** Smith, a friend of mine for the last 10 years.

I've been leaning on you for a decade to do this, and you finally have. So, thank you, **Emery**. And thank you on behalf of all people in the world who want freedom and Full Disclosure.

Emery Smith: Oh, thanks for having me, Dave.

David: We were actually driving in the car, and we were talking about the bodies that you'd autopsied, but then you told me something in the car that I think sheds some deeper light on your experience.

And I'd like us to go into that part now, even though I think it's farther along in your career.

But it helps to establish a fundamental truth, which is that insiders, typically, when you get a real one, they have lots of different, cool things that they've done.

So tell us about the Vatican.

Emery: Oh, the Vatican. Yes, yes.

So a private organization went to the DoD [*US Department of Defense*] and the mil [*military*] labs I was working at, and they needed some technicians and some scientists to go to the Vatican to look at their archives, because they know that they had some information on a craft that was taken in New Mexico.

David: So there had been a UFO . . .

Emery: That was shot down.

David: Oh!

Emery: Yeah.

David: And it was a recent one.

Emery: Yes, very recent. And they took this craft . . .

David: Why would they shoot it down? Was it hostile? Did it do anything bad?

Emery: No, no, no, not at all.

David: Oh.

Emery: No, it just got too close to some of the weapons up there . . .

David: Oh! Okay.

Emery: . . . and from what I heard, from the debriefing.

And I don't know where it crashed. I just know where it was at.

David: Do we know anything about what this craft looked like or what kind of occupants they found inside?

Emery: No, there were no occupants that was mentioned, but the craft did look like a tetrahedron.

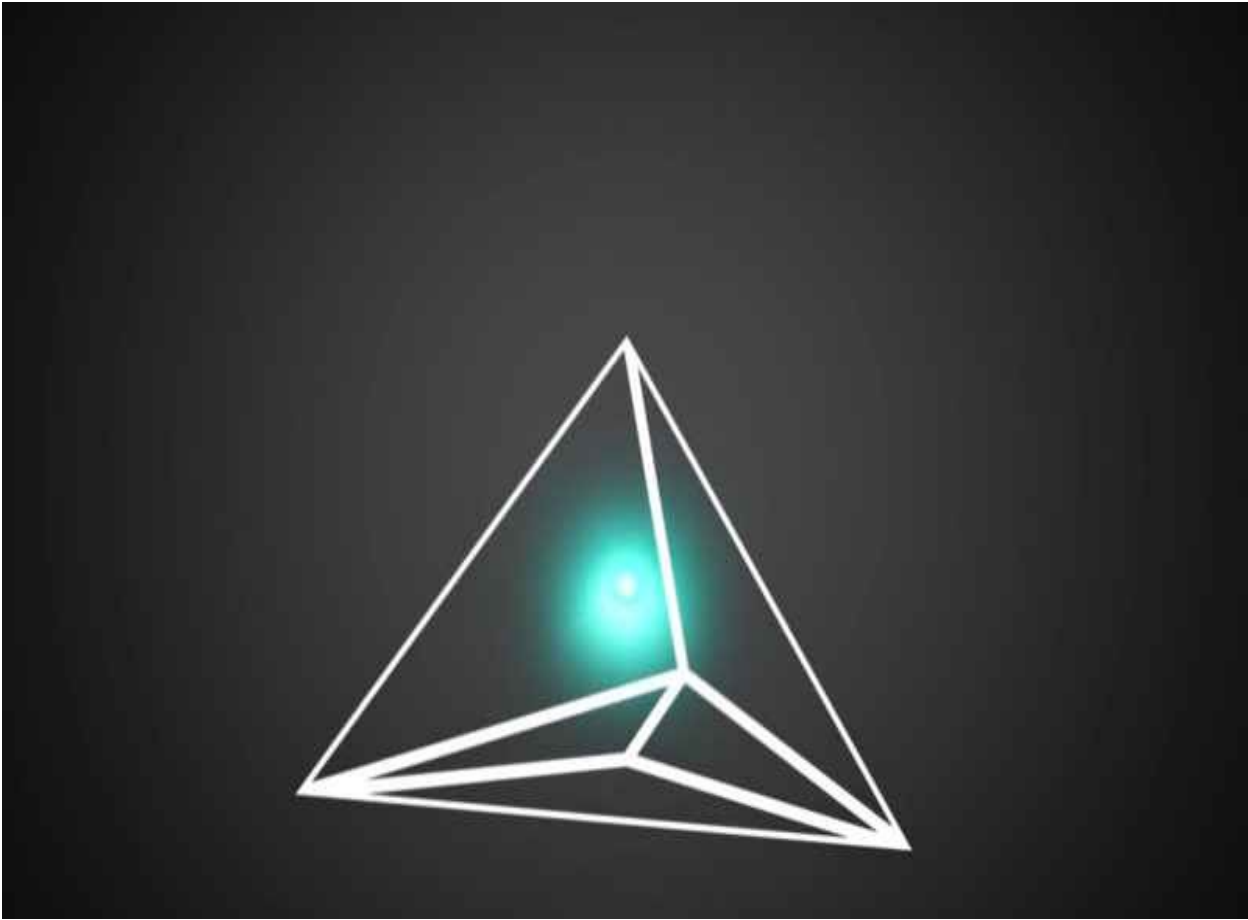

The best way I could put it is: make a tetrahedron out of PVC pipes.

David: Really?

Emery: Yep. And about eight feet in diameter.

David: Uh!

Emery: Yeah, and it has a light in the middle of it.

David: Really?

Emery: Yes.

David: And this was like a robotic drone?

Emery: It always stays centered. Ah, it could have been. But then again, a lot of these craft are conscious, actually.

David: Hm.

Emery: And it can . . . Every now and then, it'll strobe. And then it'll fill up the spaces so you can't see through it.

David: What will fill up spaces?

Emery: Like, you know, I just said it was an empty tetrahedron, like made out of PVC pipe?

David: Right.

Emery: So you could see through it, and you could see the light in the middle.

David: Oh!

Emery: Uh-huh. Yeah.

David: What color was the orb of light? Do we know?

Emery: It was blue, but it was very small, like probably three inches in diameter.

David: Wow!

Emery: Yes.

David: And the tetrahedron itself was white?

Emery: It was . . . The outside of it was like if you made one with PVC pipe and it was pure white, and it was seamless.

David: Wow!

Emery: And if you got too close to it, it would actually fill in a space of . . . that you could not see into it.

David: But I still don't know if I understand.

Emery: Okay. So if you have an empty tetrahedron that you can see through, and we're only talking about the outside lines, okay?

David: Okay.

Emery: So you could see through it, and you can see this ball.

David: Oh.

Emery: And if you get too close to it, it'll actually go solid.

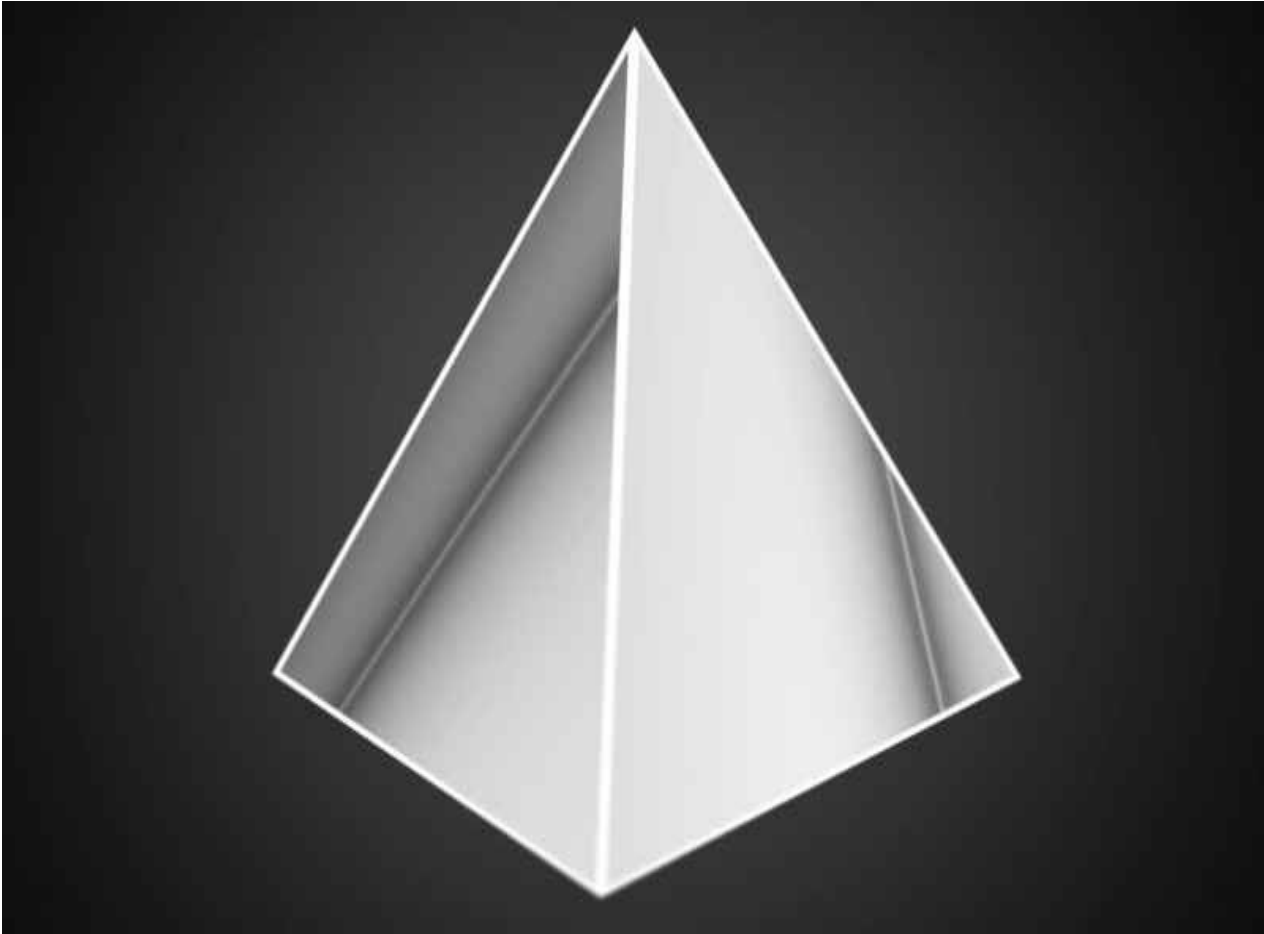

David: This tetrahedron goes solid?

Emery: Yes.

David: Really?

Emery: Yes.

David: And then what does it look like?

Emery: It's just white. It's just white.

David: Wow!

Emery: Yeah, pure white.

David: So this appears to have been some kind of drone. There were no occupants in it.

Emery: There were no occupants, but it doesn't mean . . . because that white light could be some sort of consciousness.

David: Or a being. Right.

Emery: Or a being.

David: Yeah.

Emery: So you cannot . . . Any time you see light, you have to think being first and then go from there.

David: So you're saying, if I'm getting this right, that the Department of Defense had this craft, or whatever it is, get shot down in New Mexico.

And they're drawing a blank as to what it is or where it came from.

Emery: Yeah. I don't know where it was shot down. I just know it was stored in New Mexico, . . .

David: Oh!

Emery: . . . because that's where I was at. But it was a first of its kind, so they had . . .

David: They have a very robust idea of what normally would crash, correct?

Emery: Yes.

David: They have an extensive catalog?

Emery: They have an extensive collection, I will say.

David: Yeah, ha, ha. Okay. But this skewed the charts in some way.

Emery: Yes. Yes, it gave off different, I guess, frequencies or something that they were amazed about. And it didn't show any aggression or whatever after it was shot down.

And it was still obviously operational.

David: And you say that this craft was in the category where it appears that the material itself is a life form somehow?

Emery: Well, I don't know about THAT, because I wasn't in on that part. All I know is that ball on the inside had energy.

David: Okay.

Emery: So energy and light always could mean life.

David: Okay. So what did they decide to do about this craft? If they don't know what it is, they don't know where it came from, what kind of resources can they draw upon at that point?

Emery: Well, what they do is they form a team, and they do a big background check around the world, because there's other catalogs in other countries and other religions.

And, of course, the Vatican has always been a huge database. It has a huge archive of many things: artifacts and things they have found from space and have collected over many, many, many, many years.

And they have an underground base under the Vatican.

So two scientists and myself were deployed to that area to the Vatican to an undisclosed location in the Vatican. And we took an elevator down about seven or eight floors.

David: Hm.

Emery: And that's kind of how it all started. We got permission from the Vatican. They set it all up.

We're just contractors going there to collect any type of information that would be similar to this device.

David: So is it common that there is interagency cooperation?

Emery: Yes.

David: Okay.

Emery: Usually for exchange for favors.

David: Now, you are an Air Force veteran, right?

Emery: Yes.

David: And we've often heard from various insiders that there's like an Air Force wing of the military-industrial complex and a Navy wing. They kind of broke off after World War II . . .

Emery: That's true.

David: And they've grown into these totally separate industrial complexes.

Emery: That's very true.

David: So would you estimate that most of your experience is in the Air Force side, because that's where you started, or . . .

Emery: Yeah, for this particular thing, I would say so, but they still work together when they have questions.

David: Okay.

Emery: They're not banging heads.

David: Right.

Emery: But they do like to keep their secrets together, because the more they can show the government, the more money they can get at the end of the year.

So if I have some really cool things that I've collected this year for this corporation, this mil lab or Air Force mil lab, then we get more money.

And so they don't always share the secrets of what they're doing, but they do always work together to figure out things that they can't figure out. They work always . . . They're very compliant with that.

David: So I think the military budget, even on-the-books military budget, recently was like in the neighborhood of \$864 billion – the ridiculous \$700 toilet seats and that kind of thing, and the little nuts

that cost \$65.

So the idea being that the military budget has a lot of room in it for off-balance sheet expenditures.

Emery: That is correct. You know, you could get a toilet seat for \$700. And they WILL go to Home Depot and buy it for \$2.00. And they'll buy 2,000 of them. And then the rest of that money goes where?

David: Well, apparently, you guys are fighting over it is what you're telling me now. It's like a healthy . . .

Emery: It is a competition.

David: Competition.

Emery: But from my experience, I mean, and I'm not one of the executives there by far or their financial advisers, but just from what I heard from some of the higher upper-class people in there that they usually always get about the same.

David: Oh.

Emery: So it's not this . . . They're not beating them by billions of dollars.

David: Right.

Emery: And it is actually not billions, it's trillions.

David: Right, when you encounter all the other ways that money is being generated.

Emery: Correct.

David: So if we have this craft that comes down, and they don't know what it is, just in a very general sense, if you can speculate – and I understand you might not have definitive knowledge, but I'd like your speculations. It's going to be probably better than mine.

How often do you think this kind of stuff is happening?

Emery: Daily.

David: Really?

Emery: Yes.

David: DAILY? There's crashes of UFOs daily?

Emery: Well, they may be . . .

David: I would not have expected that.

Emery: They're actually identified, because when we say "UFO", we're thinking . . .

David: Vehicles.

Emery: Vehicles. But there ARE a lot of vehicles that are recovered from space, or shot down from space, and then recovered and brought back too. And they're not always, of course, inhabited at all.

David: Right.

Emery: And a lot of these things too, actually, it's like the Trojan horse. They want us to bring this in here, so we can learn about good technology and can reverse engineer something.

David: A positive Trojan horse.

Emery: Right – a very positive Trojan horse.

David: Not like an AI infestation . . .

Emery: No!

David: . . . that swarm over the planet.

Emery: No, not at all.

David: Okay.

Emery: So, and that's what . . . It's so exciting that the scientists do realize that. And a lot of the corporations also learn about that.

The sad part is once they figure it out, it's forever for it to come to the public for us to use to help make our lives better.

David: All right. I'm still a little reeling here, and probably they are too. Every day? EVERY DAY?

Emery: Yes, every day.

David: Wouldn't there be people filming this with their phones? Wouldn't there be incident reports and . . .

Emery: Well, I think there are a lot of abnormal things people are seeing on YouTube and all these things.

David: Okay.

Emery: And probably 90% of them are fake disinformation . . .

David: Right.

Emery: . . . or fake alien reproduction vehicles that they'll fly by just to make people fearful or whatnot. So there IS this happening.

But you have to understand, this doesn't happen usually over a major city. These things are usually . . . now are being shot down in XO atmospheric areas and brought back and then brought back very carefully to the surface here.

David: Okay.

Emery: So it's not always like you shoot a jet down, and you see it streaming down, and kaboom.

David: Right.

Emery: You know, that's very rare.

David: So in a sense then, if we could liken this in some ways to a war, they are going to be very meticulous about not leaving any vehicles on the battlefield.

Emery: Oh, you will not see any vehicles on the battlefield.

David: Right.

Emery: No.

David: So whatever happens, they bring it in . . .

Emery: It's intentional

David: They take a look.

Emery: Right.

David: Right. So that would then mean, I would guess, that there probably is some sort of diplomatic relationship with various ET groups. And then when people try to get in and breach that agreement or that contract, if you will, that's when problems arise? Would you say that's true?

Emery: Yeah, just like with Eisenhower. I mean, there were some nice, good things happening with the meetings. There have been many presidential meetings with certain ET civilizations.

And I think what happens is just because the president shakes hands with an extraterrestrial doesn't always mean that the president's military-industrial complex is also part of that contract.

David: Right.

Emery: And that's the problem. So we did . . . Hm . . . Our contract is void and null now because of this problem.

David: Wow!

Emery: Yeah.

David: So if you could again speculate – and I understand that this is purely off the top of your head . . .

Emery: Sure.

David: . . . or maybe you have some briefings, I don't know. If you're saying that one a day on the average is being recovered, that would be 365 per year, how many of those per year might you think would be unconventional or otherwise requiring a deeper degree of research for them to understand?

Emery: Well, let me get one thing. When I say collecting one a day, it could be a piece of equipment.

David: Ah.

Emery: Okay? It could be an archaeological find, or it could be something from space that they have collected. Or it could be something we shot down.

David: Wow!

Emery: So those are the . . . When I say that, that's how much data we are getting in on these devices EVERY day.

David: Wow!

Emery: So that's why it's growing so much, and so much money is going into these projects, because it's an unlimited amount of . . . We can't keep up with what's happening.

So they're starting to store these things. And then certain things, certain organizations, are buying massive amounts of satellites to track these things with neutrino light detectors and forming their own ways of getting this technology as well, instead of just the military-industrial complex.

David: I want to run something by you, and it annoys me, okay? So this is a question that I ask out of some degree of anger.

But it very much upset me when I was talking to my insider, Jacob, where he was describing the redundancy of technology. That in some cases they found so much of a certain type of technology, like for example, ruins on the planet Mars, just in case we ever get there in the future, they've actually bulldozed over ancient sites and buried them, because they feel like they know what's there, and they don't want it to be so easily discovered.

Have you ever heard of things like that going on?

Emery: I've heard of things like that going on here on Earth.

David: Really?

Emery: And I wouldn't pass it by anyone else that that's happening on Mars as well.

David: So do you think then that the technology that they have in these secret programs is so immensely vast that in a lot of cases they can bring things in, and it's not really going to advance our knowledge that much?

Emery: It will always, usually 90% of the time, advance our knowledge, yes.

David: Oh, really?

Emery: I mean, if they bring any type of equipment, or bodies, or craft, or whatever it is, we are still learning. We are the medieval people here trying to get a hammer and a wheel made.

So all these little bits and pieces all still fit together sometimes. So you might get a piece today and a piece two years from now, and like, “Ah, here's the two pieces. Great!”

David: Oh, wow.

Emery: And that's why it's important now that a lot of the military-industrial complexes and the military, and the private organizations, are now teaming up for things they can't figure out, because they'll work on a project . . . they used to work on projects for maybe five or 10 years without asking for help.

David: Wow!

Emery: It's kind of like the husband and wife driving around, and the husband is not going to ask and stop for directions whatsoever, because we're too stubborn.

David: Right.

Emery: So that's kind of where it's at now, but it's different. So they're sharing information. They're sharing data but very limitedly and very carefully.

David: It does seem to me as if the intellectual capital, the, if you will, financial and informational value of having more skilled employees working on this stuff, it would appear that once we have disclosure, and we can get a lot more, potentially tens or hundreds of millions of people more, working on all this stuff, that we will quantum leap even beyond wherever they are now so much. That's what I would think.

Emery: Yes. Yeah, there's still rules, and laws, and regulations universally, but as far as technologically, we will overnight transform the world within like a week.

David: Right.

Emery: I mean, you'll be able to 3D terraform houses in any place 50' above the Amazon so you're not destroying the trees.

David: Wow!

Emery: It'll be cities will be put up everywhere. I know even our government has contacted me to orchestrate and architect a special city here that's self-sustainable, that's off-grid, has its own communications, its own electric, and all this stuff, because they're preparing to do this model everywhere.

David: Wow!

Emery: And our government is in full support of that, especially POTUS.

David: This doesn't make me think that we have any overpopulation problem at all. If you have people who can become skilled workers, we want more of them. We should be colonizing. We should be going out and developing inside moons, developing inside other planets and on the surface of these planets.

We don't need to get rid of people. We need more people.

Emery: Right. We will need more people, because once the intelligence and all of this information comes out, then everyone's going to be really smart really quick. So then people will be training immediately on this stuff.

And the secret science behind how to do all of that will be revealed.

David: Wow!

Emery: And as soon as that's revealed, you're right, it'll be like taking a flight from LA to New York, but to the Moon or Mars, to help colonize.

David: Yeah.

Emery: And it'll be that safe and that easy.

David: So I want to make sure we get into the Vatican.

Emery: Okay.

David: You go down this elevator.

Emery: Yes.

David: You're on an invited mission to try to figure out what the heck this tetrahedron thing is.

Emery: Right.

David: So what do you see? Let's . . . First, just tell me what the elevator looked like. Anything unusual about the elevator?

Emery: No, it was a very large elevator, larger than normal. You could put a car in it.

David: Oh, wow!

Emery: Normal elevator. Very clean.

David: Okay. Round, square?

Emery: No, square. Rectangular.

David: Okay. So the doors open, and what do you see?

Emery: We walk in. The floor was white. Walls were white. It was like a black rail.

David: A black rail where?

Emery: There was just like a black rail around the inside of the . . . like a rail you could hold on to.

David: Okay. On the walls?

Emery: Yeah, on the walls, about 3' up.

David: Okay.

Emery: There's no windows, no glass, nothing like that. It was just a normal elevator. It was very silent. I didn't know it actually started moving.

David: Oh!

Emery: It was like the most quietest elevator I've ever . . . You know, you usually feel the little bounce.

David: Right. Right.

Emery: There was no bounce. It was like we were sitting actually just talking, whenever we got . . .and when the doors shut, I was like, “Is someone going to push a button or something?”

David: Ha, ha.

Emery: I get antsy, you know?

David: Right.

Emery: And then I was like . . . And all of a sudden, like in a minute, the doors open. I was like, “What? Vatican elevator's broken?”

David: Are you wearing some kind of uniform or civvies [civilian clothes] at this point, or what?

Emery: I'm wearing civvies, yeah.

David: Okay.

Emery: Yeah, civvies. Nothing special.

David: So you go in after the doors open, . . .

Emery: Right.

David: . . . and what do you see?

Emery: The first thing I see is a giant auditorium-type area. It reminded me . . . and I don't like referring to movies, but in Harry Potter's “Hogwarts”, I think it was like the vault system with all the little trolls, where you look up and you see all these square vaults, but it was very rustic.

This was spotless clean. It was beautiful glass everywhere. It was just like . . .

David: Oh, my God!

Emery: . . . these huge cubicles of glass. And some were different sizes. So it was really neat.

And through these cubicles of glass were all these metal strips and lines.

And then there were these platforms about 6' in diameter that could travel to any of these things.

And there was no jerky movements to them. They just kind of flowed and then could turn, and . . .

David: Oh, wow!

Emery: . . . but only on angles. They didn't do circles, or anything, to whatever . . . And there were many people on these things doing things with the vaults and looking through them and doing things.

David: Wow!

Emery: But I didn't get to go . . . I was only on the first floor.

David: So this is kind of different. This is why I wanted you to say this, and why I wanted to do this right now is: the Vatican Library, you think it's like stacks of books and bookshelves.

Emery: Well . . .

David: This is very different.

Emery: Well, we're getting to that, . . .

David: Okay.

Emery: . . . because we had to walk through this area to get to that old . . . that other stuff you see in the movies of books everywhere and things like that.

David: But what you're describing right now is like straight out of a sci-fi movie. It must have been just breathtakingly incredible.

Emery: It was the most amazing thing . . . one of the most amazing things I've ever seen, . . .

David: Wow!

Emery: . . . because they're . . . the glass too, I was like, "This is . . ." They keep all this cool equipment behind this glass. I'm thinking, "That's ridiculous!"

Glass can break, and earthquakes, and, you know, whatever . . . explosions.

And he's like, "Oh, no. That's not glass. That's metal. That's a type of metal."

The head director . . .

David: Wow! Like transparent aluminum, maybe, something like that?

Emery: Yeah, it was like a . . . Well, he said it's a . . . he did . . . He just said it was a metal. It's not glass.

David: Okay.

Emery: That's all he said. He didn't give specifics, and I wasn't there to learn about the glass, even though I wanted to know.

David: So what was behind the glass? Let's just be clear about that.

Emery: Many different things. I mean, there was equipment back there that I've never seen before.

Some things looked like weapons. Some things looked like scrolls but on big plaques of like kind of a . . . It looked like Plexiglas, like stacks of them.

And they all had their own thing. There's no labeling on the outside of these doors, so you know.

David: Wow!

Emery: None. No numbers; no symbols. It's just a gigantic, . . . like six floors of these cubicles.

David: Geez.

Emery: Unreal. I mean . . . And like I said, cubicles there too were as small as a foot (12"). And some were as big as 20'.

David: Was the thing like a hexagon or like a square?

Emery: It was all square.

David: Okay. Wow!

Emery: Yeah, it was all square.

David: Wow!

Emery: So as we were walking, I did notice some equipment that looked like giant . . . those Dorjes, those ancient brass things that they used to hold out.

David: Yeah. In Tibet.

Emery: Yeah, in Tibet.



I noticed they were in the shape of that, but they were solid, and they were luminous.

David: Wow!

Emery: And there were no electrical cords going to it at all.

David: I've always thought that the double Dorje thing is some kind of technology that they just emulated with these little sculptures they have.

Emery: Right, but this was like a really cool, artistic, modern, ultramodern version.

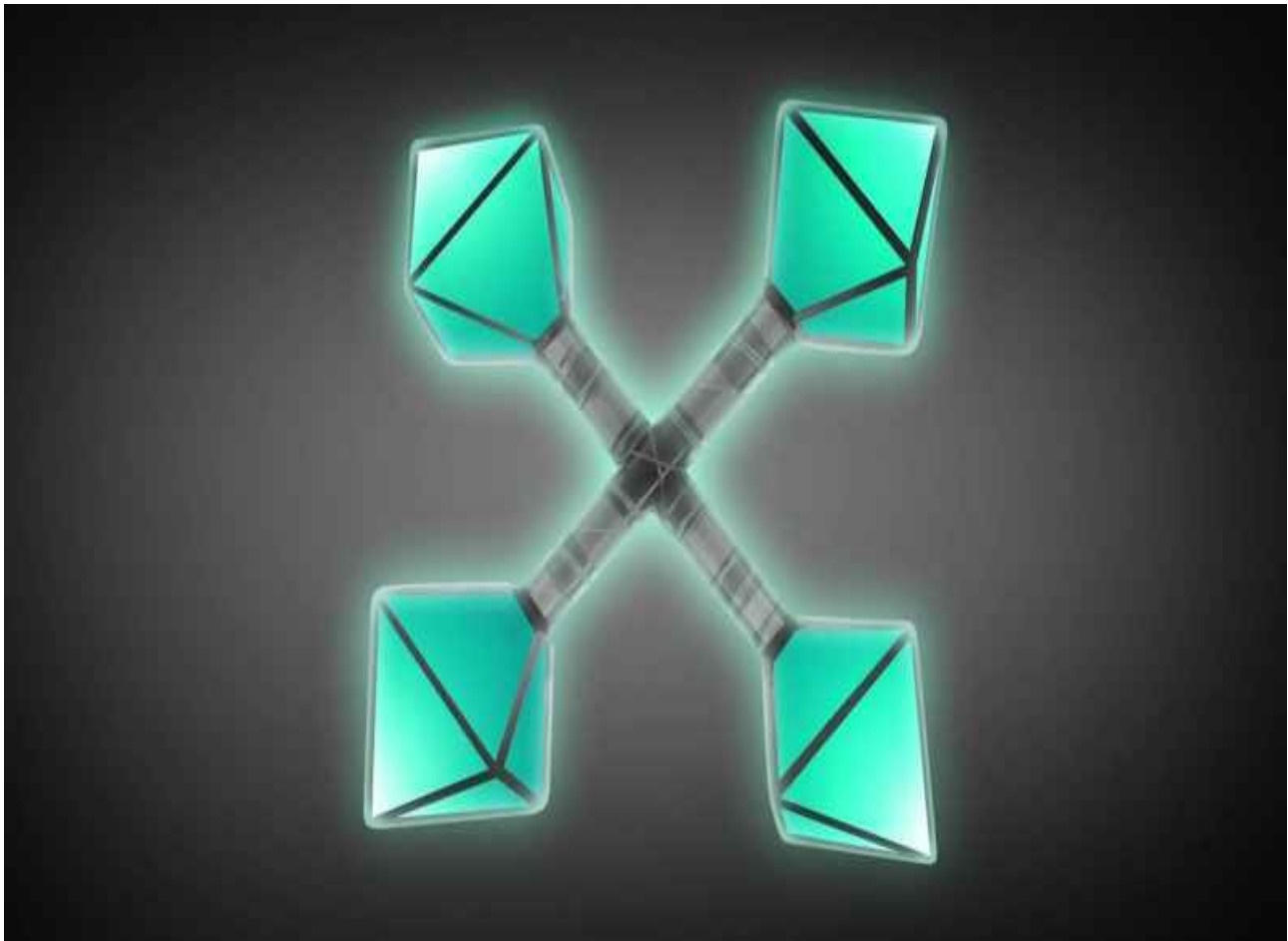

David: Wow!

Emery: It was really neat with really cool edges on it.

David: Wow!

Emery: And it was glowing. And there was no electrical cords in there or sockets. It was just there.

David: Wow!

Emery: So . . . And you have to understand I wasn't there for that. So I can't stop . . . This is not like walking through the Louvre, of course.

David: Yeah.

Emery: We're on a mission, and you just keep your mouth shut, and we go where we're going to go, which we wanted to go to the archives to find out about this, this device, or this ship, this craft with this light.

David: So what happened after you got through this majestic crystalline auditorium?

Emery: After we got through that, there was another double doors at the bottom, and they just slid open.

David: Like glass doors, or . . .

Emery: Hm-hmm, glass doors. They just slid open – just like separated.

David: Any noise?

Emery: No noise at all.

David: Wow!

Emery: It was very quiet in there. No echoing, either, which was weird for me, because I thought even like a voice would echo in this room.

David: And when you saw the people on those moving platforms, what were they wearing?

Emery: They were all in white, like those . . . you know the surgical suits that are made out of that fabric?

David: Ah.

Emery: And they had also on their heads the normal white caps.

David: Wow!

Emery: They're in a clean suit.

David: Clean room.

Emery: Right, but it wasn't surgically clean. I think whatever they were doing, they were all holding something and looking at something and looking into the glass.

David: Wow!

Emery: So I don't know what they were doing at all. I have no clue.

David: And do you think that there was anything beyond the first layer of these cages? Like was there deeper layers beyond one layer, or was it just all on the surface?

Emery: On the first floor where I was, I could not see . . . I mean, it just ended. Some were 10' deep. Some were 30' deep. You know, like I said, some were small, like 12" cubes, and some were enormous.

We walked by one that was at least 20' tall (almost 7 meters).

David: Oh, wow!

Emery: Yeah.

David: Amazing.

Emery: Yeah, it is amazing.

David: So what happens after these quiet doors open up? Where do you go next?

Emery: So now we're in the main library, I believe.

David: Hm.

Emery: And there's these giant, cylindrical, gas-controlled tubes that are probably anywhere from 6' to 3' in diameter. And there's hundreds of them that go up very, very high.

David: You said 6' to 3' in diameter?

Emery: Yeah, 6' to 3' in diameter, glass, or whatever – metal, glass, or whatever they call it.

David: Okay.

Emery: And there's windows on them that open up, and it goes up and down. And they have a thing that they hold, and they can scroll up, and then all those books go down. Like they're all on shelves, all these books, okay, and all these tablets. And they go up and down.

David: Oh, wow!

Emery: Yeah, up and down inside these cylindrical columns, which I heard were vacuumed and gas-controlled to keep them from getting old.

David: Wow!

Emery: And so they took us to this place and went to this one column. And he just brought it right up – all these different books about this particular craft. And we were able to get all that information.

David: What did the books look like, and how old were they?

Emery: Well, it looks like these books were actually translated from another book that someone wrote, because they said a lot of this was all translated. So it was all perfectly written and typed, like very new . . . just like today, like nothing fancy at all, to be honest.

David: Okay.

Emery: It was in binders and folders and whatnot. So it wasn't fancy or futuristic.

David: Okay.

Emery: It was just a huge database. But in many columns I looked at were very old things, like very leather-looking books.

And I noticed one had blocks in it. And I thought they were blocks, but they were tablets with information on them.

David: Did any of the leather books have a color cover, like a bright color?

Emery: Yes, I did see one that had many . . . like one of the columns had many colors in it, . . .

David: Yeah.

Emery: . . . and many sizes too. Like I saw one shelf had 6' books.

David: Wow!

Emery: Yeah, it looked like books. I mean, it was far away, maybe 30' away.

David: Well, when Peterson described his trip into the Vatican, he said that a lot of the books were leather-bound and that they had buckles on them . . .

Emery: Yes.

David: . . . and that they were color . . . like bright colors, like a bright red, bright green.

Emery: Yes. Yes, yes, I saw that, and it was very thick.

David: Wow!

Emery: The leather was very thick, and they did have metal on them. I've seen a lot of that just walking to where we had to go.

David: So did you guys get to take the book and bring it to a reading area, like a table or something?

Emery: Yeah, no, he pulled it out. And there's tables everywhere that are off the ground on pedestals, and he just laid it out on this 6' glass pedestal, or whatever it was, glass or not glass. I'll just call it metal glass.

And he opened it up, and he is the one who shows us. We can't touch it, actually.

David: Oh.

Emery: So he shows like, dah, dah, dah, dah, dah, dah. And there was also a translator that was there, because the English was not that good.

And there were two other of their technicians there that upkeep, like library bookkeepers. So that was really interesting, librarians.

So the next thing that happened is they opened it up, and he just started scrolling through. And we were looking at it. I was looking at it with the two scientists.

And this is what we wanted. It was like exactly what . . .

So then we asked him if he had anything else that was similar to this. And he did.

David: Hm.

Emery: So then he took us to another area and showed us another book. And they actually had sketches of the same exact thing . . .

David: Wow!

Emery: . . . that was ancient.

David: Really?

Emery: I mean, I don't know how old it was, but it was pretty old because it wasn't written on paper – this giant sketch scroll that someone, some monk, had drawn.

And it had a lot of physics on it, and it was all in a different language.

So we were able to get a picture of that downloaded, and we got a copy of that book, and we escorted that back to home.

David: Did you get a sense from just what was spoken out loud or translated as to what this thing was or where it had come from, anything that specific?

Emery: No, because once I got back, I was pulled off of that project. All I can tell you is it was, I think, I believe, an intentional device that was put here to help. And then that was it. I've never had a part of that project again.

David: When it was in this foreign language, and you said it wasn't really like a book, what was it on? What did it look like?

Emery: It looked like wax paper.

David: Hm.

Emery: Yeah, and it looked like it was black wax paper. I think you could maybe . . . as you wrote on it, whatever that stuff was would peel off so you could write on it.

David: Hm.

Emery: It looked like something like that.

David: Wow!

Emery: But I wasn't able to touch it at all, but it was the exact same device – I mean the exact same craft, but it was a lot larger in form. It was probably 10 times larger from this person's . . . Whoever sketched this, it was 10 times larger than the one we had.

David: So how do you think that idea that we discussed about people starting to be trained as disclosure happens? How do you see that unfolding?

Emery: Well, the first thing that's going to happen is everyone's going to want to know where to go.

“I want to be this person. I want to help. I want to know how to grow something overnight – a tomato. You know, I want to know about anti-gravity – how I can make my car float.”

So people are going to want to know right away, and it's going to be up to the government what kind of information is going to be released to the universities and public, because they're going to do it correctly.

They are going to do it through probably universities first.

David: Right.

Emery: And hopefully, a lot of the other scientists that are out there will pick up on what they're doing. And then they'll be able to live stream it and have a source way to get it to the public, where other people can just start thinking about it, because you have to free-source everything in order to stimulate the entire planet into wanting to do something instead of holding it in universities and saying, “Well, you have to learn this first, and dah, dah, dah, dah.”

David: Right.

Emery: But I think the education part will also be a lot easier in learning this stuff, because with the advent of all these new technologies coming out, also comes out technologies how to learn faster, . . .

David: Yeah.

Emery: . . . how to take care of yourself better. You know, a lot of these things are daily things that we do are going to be much simpler.

David: Very cool.

Emery: Yeah.

David: All right. Well, thank you, **Emery**, for being here. And I want to thank you for watching. This is “[Cosmic Disclosure](#)”. I'm your host, [David Wilcock](#), with our special guest, **Emery** Smith.

Cosmic Disclosure: Bioship

Season 10, Episode 5

David Wilcock: All right. Welcome back to “[Cosmic Disclosure](#)”. I'm your host, [David Wilcock](#), here with **Emery**. And in this episode, we're going to talk about organic craft.

Emery, welcome back to the show.

Emery Smith: Thanks, Dave. Thanks for having me.

David: So in order to open up this discussion, let's go back to your time at Sandia because we really have barely scratched the surface of that yet.

Obviously, we're going to get into this organic craft thing, but before we do, you had talked about the fact that, in the beginning, you were getting these partial bodies.

After you got through the salmon fillet phase, and then you got through the arms and legs type of phase, you got partial bodies.

Emery: Correct.

David: So the first partial body that you told us about was, again, what?

Emery: The crossbreed tiger-type human hybrid.

David: Okay.

Emery: Yeah. That was the one . . . It's very disfigured and dysmorphed.

And then the next one that followed that was the more of the smooth skin with the leopard skin, but with iridescent – like the peacock feather colors – skin.



David: Hm.

Emery: And that face was a little bit mutilated, so I couldn't see the actual . . . but it was a very normalized skull, just like a human. The body was very thin and lanky.

And these bodies is what brought me to see craft, because later on, some of the tissue samples I was taking, they asked me to come take samples from a completely different part of the base, or this underground facility, that I would have to travel to, and also escort those samples back to my base, which was unusual for me to be a carrier, but it was all within the underground.

David: So if I'm getting this correctly then, what you're saying is, that in certain cases, you were working on a body, or a partial body, . . .

Emery: Right.

David: . . . but then they had reason to believe that there might be some biological similarity between the body and the actual craft that the body was in.

Emery: Exactly.

David: Wow!

Emery: Exactly. And so I would actually . . . They would come on the intercom and actually say, “All right. That's enough.”

Because I'm doing samples the whole time and giving them . . . As soon as I get a sample, I put it through the window. So they're already testing, in the back, the genetics of this thing.

So I just remember them coming on and saying, “Okay, That's enough, Smith. We need you to go do a run.” And I didn't even know what that meant, because I'd never done a run.

David: Do you think that the people that are on the other side of the glass, that you pass these samples into, are more specialized and skilled workers than you?

Emery: Oh, absolutely.

David: Okay.

Emery: I mean, I'm just a technician. These, probably, are the scientists and geneticists, you know, that taught me later on all about that kind of thing.

These people are probably those people grabbing it, running it through some advanced fast scanner of some sort. because they were always . . . [They would] immediately come back, within minutes of me giving a sample, as I'm taking another sample and say, “Stop that. Go up and grab something from the inner ear,” you know, or something like that.

David: Oh!

Emery: So they were immediately, probably, another team behind these windows that are trying to find something out specific from this species.

David: Did you ever get to meet any of them? Or did you recognize any voices as being common voices?

Emery: Yes, I did later on, but I was not really allowed to hang out with them or talk to them.

David: Right.

Emery: But I did hear . . . You know, I see people in the locker room. I see people in the cafeteria. I see people on the outside, but not until way later on down the road did I actually get to meet people that were actually those people.

David: Interesting. So do you think, in some cases, that the tissue was able to be reproduced, like to be grown?

Emery: Yes. Yes, for sure. That's definitely what they were doing. They were trying to reproduce these cells.

David: Okay. So then, you said that at certain points they might ask you to take tissue from the inner ear and stop what you were doing.

Do you think they have a database of the tissue samples, and they're comparing . . . when they make tests, they're comparing it to other parts of . . .

Emery: YES! Yes. Like it depends . . . They're not only taking the tissue to reproduce. They're studying the tissue. They're studying the eardrum. They're studying the phrenic nerve. They're studying the heart muscle of this being. They're studying all sorts of different parts of this body for some reason, for their own . . . Who knows.

So it's not just one thing. They're doing many different things with the body for their own reasons.

David: Yeah.

Emery: Maybe they just need that optical nerve because they want to know how they see. Maybe they need that tendon to see what those tenocytes are made out of, because it replicates so quickly in a Petri dish – one of the hardest cells to replicate.

So I think they're just studying this like we are. I think some of it sometimes may be used for evil, and I think some of it is just trying to learn and find out, what are these beings, and where they come from, and what are they made up of, and so forth.

David: All right. I want to run something else by you since you brought this up. I think it's a fascinating thing to discuss.

Well before I ever met **Corey Goode**, or . . . I knew of him, but we hadn't gotten into this stuff till 2014, 2015.

I had been speaking to this insider, Jacob. And he told me, at some length, that the Draco Reptilian beings had essentially been all over our galaxy looking for various genetic materials.

And then they had taken the very best of the things that they found and had somehow spliced it in with themselves and had created a sort of super being out of themselves.

Do you think it's possible that we could be on a similar trajectory right now by all this genetic research that you're talking about?

Emery: Yes. I agree with that tremendously, just because of all the different requests and the different briefings I've been involved with in this MILAB.

And not to say it was . . . Like I always tell you, not to say that it was owned by Sandia or Los Alamos. Those are just names for cover-ups of corporations.

David: Yeah.

Emery: People need to know that as well.

David: Right.

Emery: It's just that's where I was. That's the area I was.

David: Right.

Emery: Now, getting back to your question. Yes, I believe they were trying to get this DNA and somehow mix it with human DNA, and create, or inject, some inoculation into a human being to see if they could mutate and have different factors and different abilities that beings have.

David: Well, like eagles . . . Apparently, an eagle could see a dime from the top of the Empire State Building on the sidewalk.

Emery: Exactly. Right.

David: So if we had THAT kind of vision, that would be exciting.

Emery: Yes, it would. But then I would have to clean my house extra, extra, extra hard.

David: Ha, ha, ha.

Emery: Because I don't like dust.

David: Okay, so at one point, you – or maybe more than once, but at least once – you were called in to a different location . . .

Emery: Yes. Right.

David: . . . because of this craft being organic, they thought.

Emery: Yes.

David: So let's talk about that now.

Emery: Well, that's when I said they were like, “Stop what you're doing.”

No one's ever said, “Stop what you're doing and go change out” or whatever. And “change out” just means get out of the spacesuit.

So that's what I did.

And they were right there, and they were like, “We want you to go here and take the tube, and you're going to be dropped off here, and so-and-so will be there to escort you to this area.

And that was the longest ride I've ever been on a maglev tube.

David: Like a sub shuttle?

Emery: Yeah, it was a sub shuttle capsule. It was a capsule, yeah.

Because you can't ask anything. You understand, you cannot, you know . . . They did tell me that this being came from this craft. They did tell me that.

David: Hm.

Emery: And that I was supposed to take these samples from this part of the craft – I had my folder with me – and was escorted to this – you know, this was one of the first times I rode this thing – and got there.

These two guys came out. One was a security guard, and one was a scientist. And there was no other security. Like no . . . You didn't even have to pass through anything.

So it must have been part already . . . Once you get under, then you can go pretty much anywhere.

David: Can you describe what the room looked like once you got out of the capsule?

Emery: Yeah, sure. It looked just like a very clean, New York subway station.

David: Oh, wow!

Emery: Yeah.

David: Okay.

Emery: But it was very . . . another all white area, very clean, very silent. You could hear a pin drop.

David: Did you have some sort of container with you for samples?

Emery: No, nothing. I had the folder.

David: But what do you do with the sample?

Emery: Well, they have everything there.

David: Oh!

Emery: Just like this operating room I was in . . . THIS room . . . this thing is in a huge operating room . . .

David: Right.

Emery: . . . you know, this craft.

David: Oh, wow!

Emery: Yes.

David: So you walked into some sort of room where the craft was?

Emery: Well, first I had to go change. They made me change again into another . . . very similar like a locker room, but I didn't see any colors on the floors like in the hallways I told you about, the color codes.

David: Ah, right.

Emery: And there was always someone with me. They wouldn't let me be alone.

So I walked for at least 10 minutes down a very long, white hallway. There were many doors on the sides of the hallway, like every 100 feet.

And the door opened, and there I was in this giant – what I would call – a sterile hanger.

David: Wow!

Emery: A sterile hanger is what I'll call it.

And there was this craft there, and there were many people there, a lot of people running around. They were all, of course, in clean scrubs, white . . . had the white jackets.

David: Now, you would assume a couple of things, okay? You would assume this is an underground base.

Emery: Absolutely. Yeah.

David: That it's on Earth most likely. Or we don't really know that, right, because the tube could have taken you to another planet, potentially.

But they didn't tell you one way or the other, I assume.

Emery: [*Emery shakes his head “no”.*]

David: And that those other doors would have other craft of some kind in them as well.

Emery: Oh, for sure.

David: And they made sure that you only went to the one door, so you couldn't possibly have gone and tried to open another door.

Emery: There's no way. They had biometric . . . They had so many ways . . . Just to get in that door, he did the same thing we would do at the top of the facial recognition and the hand print.

David: Wow!

Emery: Yeah. They're getting a little bit more different now. Now, they're doing the DNA thing. But anyway, we'll get into that in another . . .

David: So what do you see? What does this thing look like when you walk into the room?

Emery: It's hard to explain, but if you ever ate ice cream, . . .

David: Okay. Ha, ha.

Emery: Like if you had an ice cream scooper, and you make those round scoops. And if you ever made jello in one of those containers where it goes like this, and then like this, and then like this. [*Emery uses his hand to show a three tiered jello dish.*]

David: Oh.

Emery: Okay?

David: Yeah.

Emery: Do you understand? I don't know what shape to call that.

David: It was a jello tree.

Emery: It was like a jello tree. Ha, ha. It was.

And . . . It was like this. [*Again, **Emery**, repeats the same hand motions.*]

And it was the most beautiful . . . I don't like the color red, but it was the most beautiful color red I've ever seen.

David: Hm. Glossy?

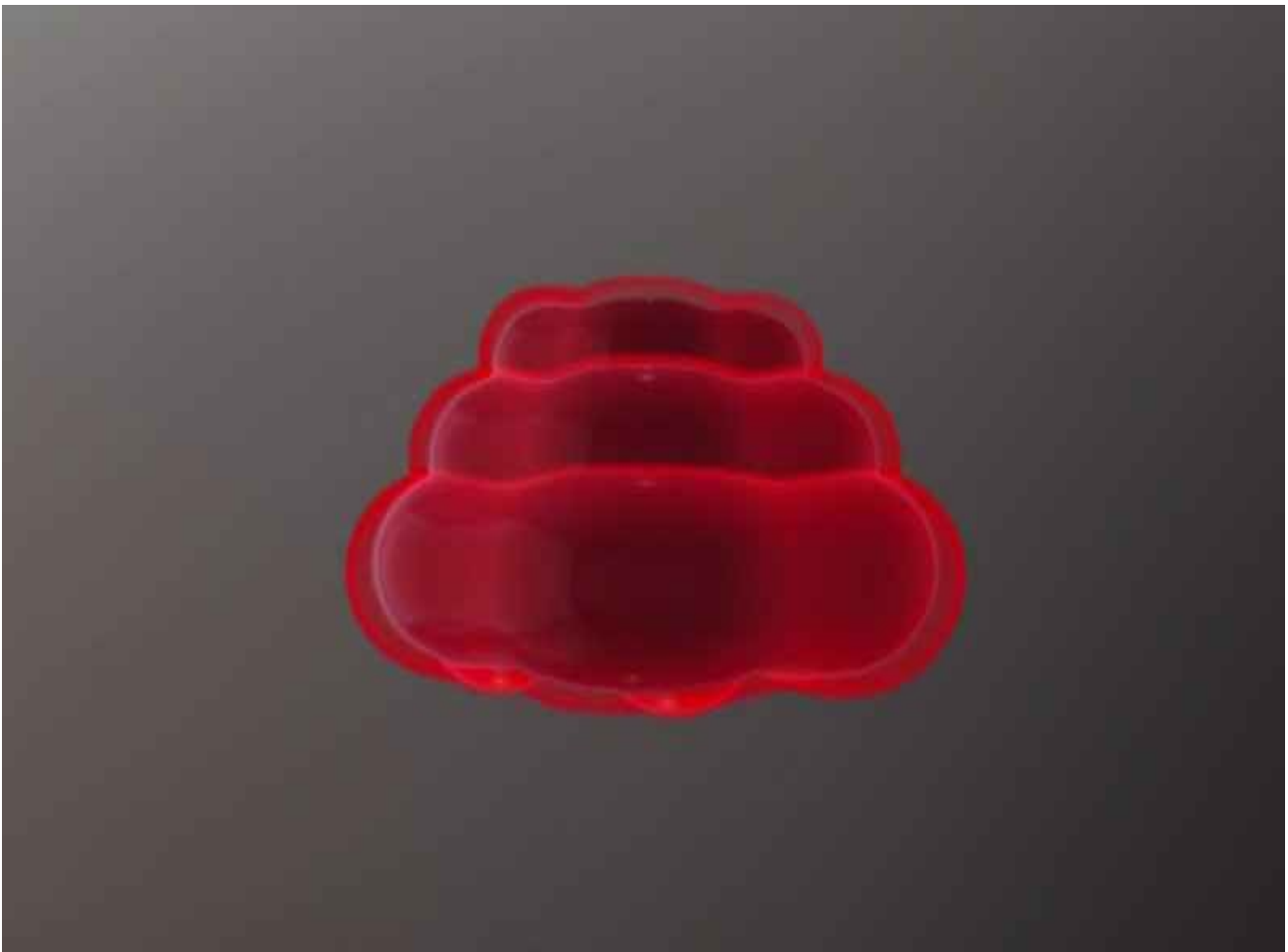

Emery: Yes. Yeah. Very reflective.

David: Any seams or just smooth?

Emery: No seams at all, completely smooth. And it did not give off any light, but it was kind of transparent and looked kind of like jello.

David: You could sort of see through it?

Emery: Yeah. It was kind of transparent, a little bit.

David: No discernible features on its surface? No writing?

Emery: Nothing?

David: No windows?

Emery: Nope.

David: Huh!

Emery: That was it.

David: Did they know how the beings got in or out of it, of the craft?

Emery: Yes.

David: Okay.

Emery: Because I had to go inside.

David: Oh, wow!

Emery: Yeah. And that was wild.

So I have this schematic. I have actually two other technicians that are here – they work here – and they're with me, with all the sampling containers, and all the . . . You have to do this in a very sterile fashion, you know, with special instruments, and it's all right there.

And these two guys . . .

David: Was the schematic on something like your folder?

Emery: Yeah, it was on the folder.

David: Okay.

Emery: This exact craft was on the folder – head-to-toe, inside, outside, everything.

David: Okay.

Emery: Anyway, so these two guys are with me. We're walking up to the craft, and I'm allowed to share . . . They know, of course, everything I'm doing. They're assisting me, which is cool.

So I go to this point on the craft and, basically, cut a piece of the craft away with a special device.

David: Hm.

Emery: And it was just like the tissue from the being.

David: Really?

Emery: Yeah. Same consistency.

Which, I didn't tell you about that specific being, by the way.

David: Okay.

Emery: But it was very [much] the same consistency of that.

They took me around to the other side, and I took another piece and went underneath and went in the middle of this thing, because it's suspended.

And it is suspended. It has some sort of . . . There are . . . I don't know if it was metal, or what it was, but it was on something that was keeping it up in the air.

David: Like a chassis of some kind?

Emery: Yeah. They had built something to keep this off the ground about 9', 9'~10', I would say.

David: Did it move or wiggle at all? You say it was like jello. I'm just wondering how far we can take that analogy.

Emery: No, it was solid . . .

David: Okay.

Emery: . . . but the consistency and the transparency of the first inch of this craft was transparent, like Plexiglas. You could kind of see into it.

David: Wow!

Emery: And then it just stopped, because it got darker. It got darker, I think, with the color, as you looked in.

David: So you go underneath it, and what do you see? How do you get inside?

Emery: So underneath are all these other round cup . . . like if you had cut a baseball sized sphere in half, and now you have that round cup, and you would pop it on the bottom of this craft. [*Emery motions that the round portion is facing downward.*] There was like thousands of these little bumps, these half spheres on it.

So I was also instructed to take this sphere near the center of the craft, which was kind of hollow.

And I did. And it just came right off. It was not like something you had to take a chainsaw to. It was very simple. It was like cutting into human tissue or tissue from an animal.

David: Was this some sort of beam cutter, or was it more of a scalpel?

Emery: I'd rather not say anything about the exact device.

David: Okay. Okay.

Emery: But all I can say is it was made for cutting pretty much any type of tissue without destroying the tissue.

David: Ah!

Emery: And that'll probably come out to the public soon.

David: Okay.

Emery: So we took that and went down the center. And in the center, they had this little device like you see in the warehouses that go up and down.

And we got on this thing, and it lifted us up, and it goes all the way up into the thing. But it's just a wall with all those bubbles on it again.

David: Oh, wow!

Emery: Yeah. So I don't know if that's the inside, because it was hollow on the inside.

So I went all the way to the top, and there was this one big, big bubble on the inside of this thing. Big sphere. 3' in diameter.

They would never allow me to go in there if it wasn't safe. Of course, it wasn't radioactive, but it had this glowing . . . kind of like on your Apple computer, that scary Apple computer light I don't like to see at night. It's like “a-a-a-ra, a-a-a-ra”.

David: Yeah.

Emery: It was like that. So it was doing this thing, and I felt kind of bad. I was like, I think maybe this thing might be still alive or something.

So I took a small sample of that, a very small sample. That's what they asked for – a small sample of like a punch biopsy, we would call it. It's probably like the size of an eraser tip. That's how much I took.

And I handed it off to the guys. They wrapped it all up, put it in a special box for me, and next thing I know, I'm back being escorted right out.

The whole thing took less than two hours.

David: Is the box clear?

Emery: No. No, it was a silver box, and it has inside a special canister that regulates temperature inside the box.

And the box is specifically made for these samples, like already pre-cut. [It is] kind of like you get those pelican cases, and they pre-cut the insides of them out. It was just like that, but it was vacuum-packed and vacuum-sealed, and it was very lightweight.

David: So let's talk about this . . . This craft is so bizarre. It's so unlike what any of us would have expected you to say.

Emery: Yeah.

David: Let's talk about the being now.

Emery: I know it sounds crazy.

David: No, it's cool. Let's talk about the being. What was the being like?

Emery: The being was very similar. It had a red consistency. And it was very . . . Remember I told you about that jelly-like creature, like we talked about, the transparent one before, which we'll get into later?

David: Uh-huh.

Emery: But this one was solid, and it was just perfect human shape. It had a face, though, that comes to a point instead.

David: Really?

Emery: Yeah. So the face comes this way. [*Emery brings his hands from the sides of his face toward this nose and mouth showing more of a pointed edge than rounded face.*]

It reminded me of . . . If you get an acorn – the shape of an acorn.

David: Okay.

Emery: And you know how it does have this cup-like . . . you know, it's not perfectly round. It has this teardrop-type . . .



David: Sure. Sure.

Emery: And if you get the teardrop, and then you just squish it a little bit, it was just like that.

David: Really?

Emery: Yeah. But by squishing it, not that it would bulb out, but it would come to a point.

David: What was the size of the facial features compared to the size of the head? Like if you could map it out with . . .

Emery: It was very similar to a human's.

David: Oh!

Emery: Like, as far as how far the eyes were . . . because that's one thing we measure. We measure across the eyes. We do a symmetrical test like plastic surgeons do.

So we want to see symmetry. We always measure all of that, and we also have a scanner that goes over

the whole body to 3D replicate it, and models.

So every creature they have is already 3D model replicated.

David: Wow!

Emery: And so there's a whole museum of this, by the way, of these craft and all the beings, . . .

David: Really?

Emery: . . . all 3D replicated in many different materials. It is like this secret museum with all this stuff in it that's locked away somewhere.

I don't know where it's at. I have no idea. But I have seen many of the models in the projects for specific beings.

David: So when you say the eyes were white, are they round? Are they almond shaped? Are they like human eyes? What would the eyes look like?

Emery: No, they were more round than the typical almond shape, but they were the same size.

And this creature was probably 5' 5", about 5' 5", 5-foot, 5-inches tall.

David: Was it just all white, or did it have something like an iris or pupil?

Emery: No, there was a different color – white in the middle, but it was still all white.

But there was a circle in the middle that was whiter than the rest of the eye. So you could see that.

And I was not . . . My part of that being was not to have anything to do with the face or the eye for sampling. I was actually down low doing something with the reproductive system, taking some reproductive organs out, when they told me to stop and go to do the run.

David: Did these beings have a skeleton?

Emery: Yes.

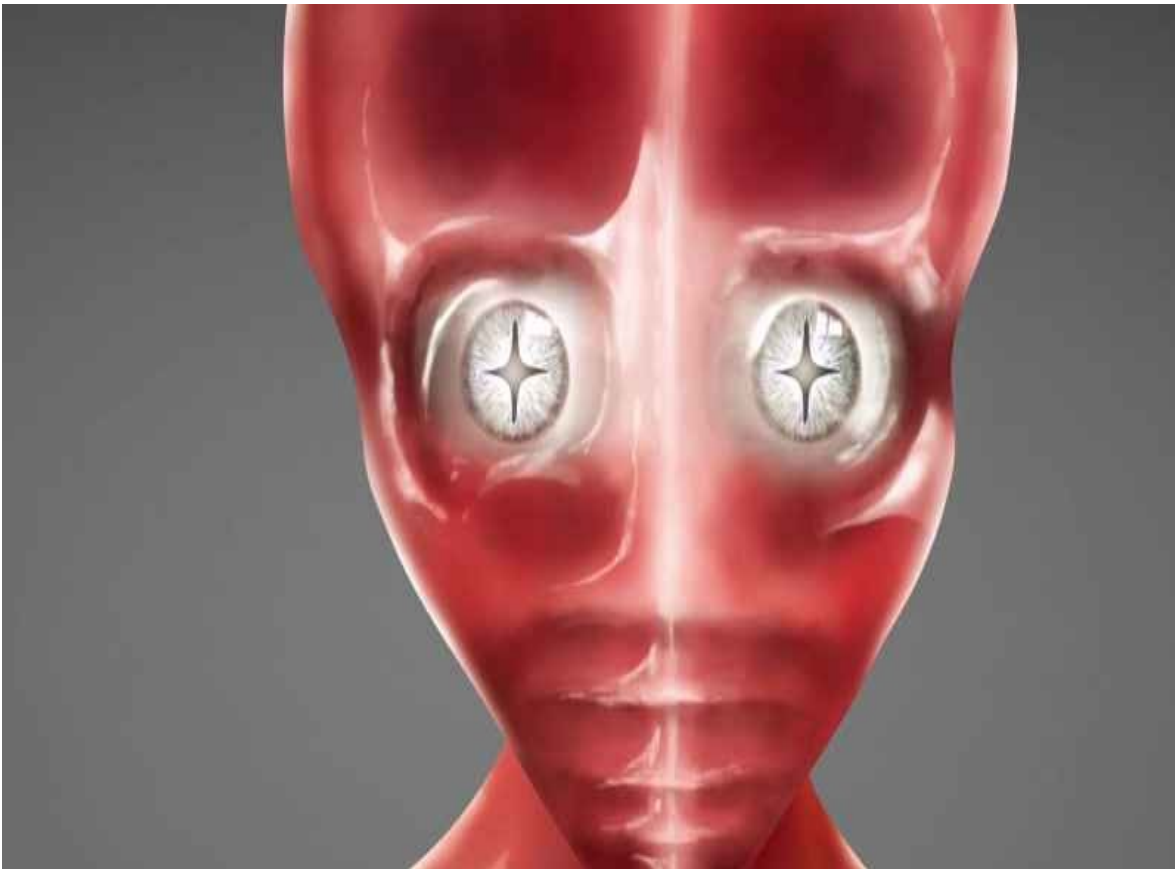

David: And how similar to us would the skeletal structure be, from what you could tell?

Emery: Just from where I was working at in the pelvis, it was very similar. I didn't see anything different.

I did not see the X-ray of that, or the CAT scan, or MRI, or what we call the . . . Well. we have a special scanner that scans the whole body. And you can really see everything all at once before you go in, but I didn't get to see it on this being. I only got to see the scan for the reproductive area.

David: How many . . . Did it have hands like we do?

Emery: Yes.

David: And how many fingers?

Emery: But they were smaller. They were smaller and thinner.

David: Okay.

Emery: Yep.

David: How many fingers?

Emery: And longer. There are five fingers.

David: But longer fingers, you said?

Emery: Yeah, they were longer – a lot longer than our fingers by . . . You know, I have a size 9 hand, which is pretty big. I would say these creatures would probably have fingers maybe 30% longer than our fingers.

Yeah, they were very long and very thin. And they did have fingerprints.

David: Hm!

Emery: Yeah, they had prints on them.

And their skin was just like this [*Emery points to his skin*], but it was red.

David: Oh, so it was actually more like a human in the way that . . . the texture of the skin.

Emery: Yes.

David: And what kind of red would you say it was, like if you had to describe the red a little more in detail?

Emery: Like a brick red, rose red, if you mix that together. It was a nice red. It was like a matte brick red.

David: Okay.

Emery: But not as dark as brick red – a little bit lighter.

David: Did it have any body hair?

Emery: No.

David: Okay.

Emery: None.

David: What would be the proportions of the skull to the body compared to one of us?

Emery: The skull was a little larger than a normal human skull, and the torso was smaller than our torso. But the legs were longer, and the arms were a lot longer than our arms, to say the least, . . .

David: Wow!

Emery: Yeah. . . . as far as symmetry.

David: So do you think that if somebody who didn't know anything were to have one of these walk up to them, with these white eyes and red skin, do you think they would be terrified?

Emery: Well, . . .

David: Or did it have sort of a noble look to it?

Emery: . . . I don't believe so. Or course, the fear that's installed and programmed into us, yes, maybe. But you have to understand, they don't . . . when you approach, usually, extraterrestrials, you're going to know right away.

Like that guy hiding in the corner as you're walking around the alley, he just doesn't feel right. You know, you get that feeling.

You know, never use this [*Emery points to his head*]. Always use your heart to feel.

And I think that, for the most part, on first seeing something, you could possibly maybe have a fear factor involved if you have not been in these projects, of course, or have never seen this, and you're 15 years old, and you're in the woods, and here this thing is.

Yeah, they're probably going to scream bloody murder.

David: Ha, ha, ha. Right.

Emery: But then again, if this was walking down the streets of New York, I think most of the people would be more enticed about it and not go throw rocks and hatchets at it.

David: Sure.

Emery: I think they would be coming up and . . . Here you have this being with its arms open, with no weapons, not hurting anyone, not saying anything, let's say, and emanating a very good peaceful energy, or negative energy, whatever the being is.

People are going to respond in the right way.

David: Yeah.

Emery: I believe in the people. I believe people will do the right thing.

David: What was the most physiologically abnormal or different thing about this being that you saw either on the MRI or in the autopsy?

Emery: It was the uterus. Yes.

David: What was different about it?

Emery: It had four chambers.

David: REALLY?

Emery: Yes.

David: And did they have any speculation as to what that might be for? Did it have multiple . . .

Emery: It can have multiple children all at the same time . . .

David: Wow!

Emery: . . .4 children, or 6, or 8, or 12.

David: Very interesting.

Emery: Yeah.

David: Is that something that might be common, or is that kind of unusual?

Emery: That's very unusual. It means that species can multiply very quickly. And they have a way of measuring the chemicals in the body to measure how fast they can gestate, which is really cool.

David: Here's what I don't understand: the uterus has all these chambers, but it would appear, based on conventional human gestation, that the baby has to grow to a large enough size to really kind of fill the womb.

How could a being have so many chambers and still have the offspring able to actually be born and be healthy?

Emery: We believe that this being only has babies once in their lifetime. And it's possible, after that, they die shortly after.

David: Really?

Emery: Yes. But that's inconclusive. That was just where it was left with me.

David: Do we know anything about what these beings are called or where they're from?

Emery: Yes. Ha, ha.

David: But you can't say, or can you?

Emery: No. No.

David: So it's really bizarre to me to try to understand: how do you get an organic craft that looks like the body?

I mean, if people didn't have the respect for you that they had in previous episodes, this whole thing might sound completely, totally ridiculous.

But yet, on the other hand, the way you answer my questions, I always use forensic techniques. I jump around, and I ask really specific details, . . .

Emery: You're good at that.

David: . . . and you don't miss a beat.

Emery: No.

David: So this is a very strange thing we're talking about.

Emery: Yes. So the craft are made in space. They're made by harmonics and frequency and sound. And they are also, just like I can say, for example, your own pet. And what that means is: you have a good conscious connection with this craft.

Lots of craft can be made from your own DNA, have a piece of your DNA in it, and that allows you to consciously assist with the consciousness, you know, speak to the craft telepathically, and also move the craft without doing anything.

David: Hm.

Emery: The cells on those craft are living cells. And without getting too far into the physics and science, that doesn't exist yet, which will sound a little crazy, those cells have micro/nanoparticles of computer technology in them.

David: Wow!

Emery: Yeah. They can store energy. And we're talking on a super nano level, you know, very, very small.

The cells themselves, like, one day you asked me: "How the heck do these cells, or these synthetic cells, work like the mitochondria?"

And I was kind of hesitant to really tell you, but they're like micro capacitors inside these cells that self-regulate, so the whole body, and every cell in that craft, is actually speaking to itself.

David: And I think you had said at one point that, in some cases, it's like a hexagonal matrix?

Emery: Yes.

David: Like a honeycomb?

Emery: The scaffold is sometimes like a hexagon, like a honeycomb. And that allows cells to go in there, and grow into there, and be happy.

But that scaffold, also, is the whole part of the craft that allows the craft to communicate with the cells and the user.

David: So you're saying that they can grow a craft in space?

Emery: Yes.

David: And how prevalent do you think this is amongst extraterrestrial civilizations that are advanced enough to travel here?

Emery: I think it's a common thing. They learn how to produce gravity, a gravitational field – an electromagnetic field that envelops the craft and the person, so they have their own atmosphere, and their own gravity.

And that's why they can go a million miles an hour and turn at a 90° turn, because they're in their own gravitational force that has nothing to do with a planet or anything else around them.

David: I guess one of the things that . . . If we're going to really get speculative here . . . People might wonder, if the craft would become sentient and then perhaps turn on its owner at some point if it wasn't feeling respected?

If there could be some danger in having a being with free will that is your spaceship?

Emery: THIS is where it gets really interesting. The craft IS you. So YOU are the craft.

Now, if you are suicidal, then the craft will be suicidal.

David: Hm.

Emery: If you are having a good time, then the craft is going to be happy too.

And it feels this way on a craft. You can actually feel this back and forth.

You know, it's not operating really on its own as much as you think. It is its own sentient, but it only feels your emotion, which is really neat.

David: Wow!

Emery: I've been on craft before where I felt like . . . the best way I could put it is: I felt like it was my pet dog, because it was just so funny and cuddly and hilarious.

David: Wow!

Emery: But at the same time, it was very obedient like a dog.

David: Interesting.

Emery: It would never turn on its owner. You know, although some dogs do, you know what I'm getting at.

David: Right.

Emery: I'm getting at that point where it's a very beautiful connection between the beings and their craft.

David: Well, it makes sense you would want to design it that way, so it was safe.

Emery: Right. I'm going to program it not to bite me anymore. Ha, ha.

David: Right. Ha, ha.

All right. Well, **Emery**, I want to thank you for being here. And I want to thank you for watching. This is [Cosmic Disclosure](#). I'm your host, **David Wilcock**, here with our special guest, **Emery** Smith, talking about organic spacecraft. Thanks for watching.