

ATLANTIS RISING

Number 26

U.S. \$4.95 / Canada \$5.95

JOHN MACK in the HALL OF MIRRORS

Len Kasten

and Startling New UFO Abduction Research

WERE the PYRAMIDS Poured?

Chris Dunn

with New Light on a Controversial Idea

The PRIEST and his TIME MACHINE

John Chambers

Did the Authorities Try to Hide the True Story?

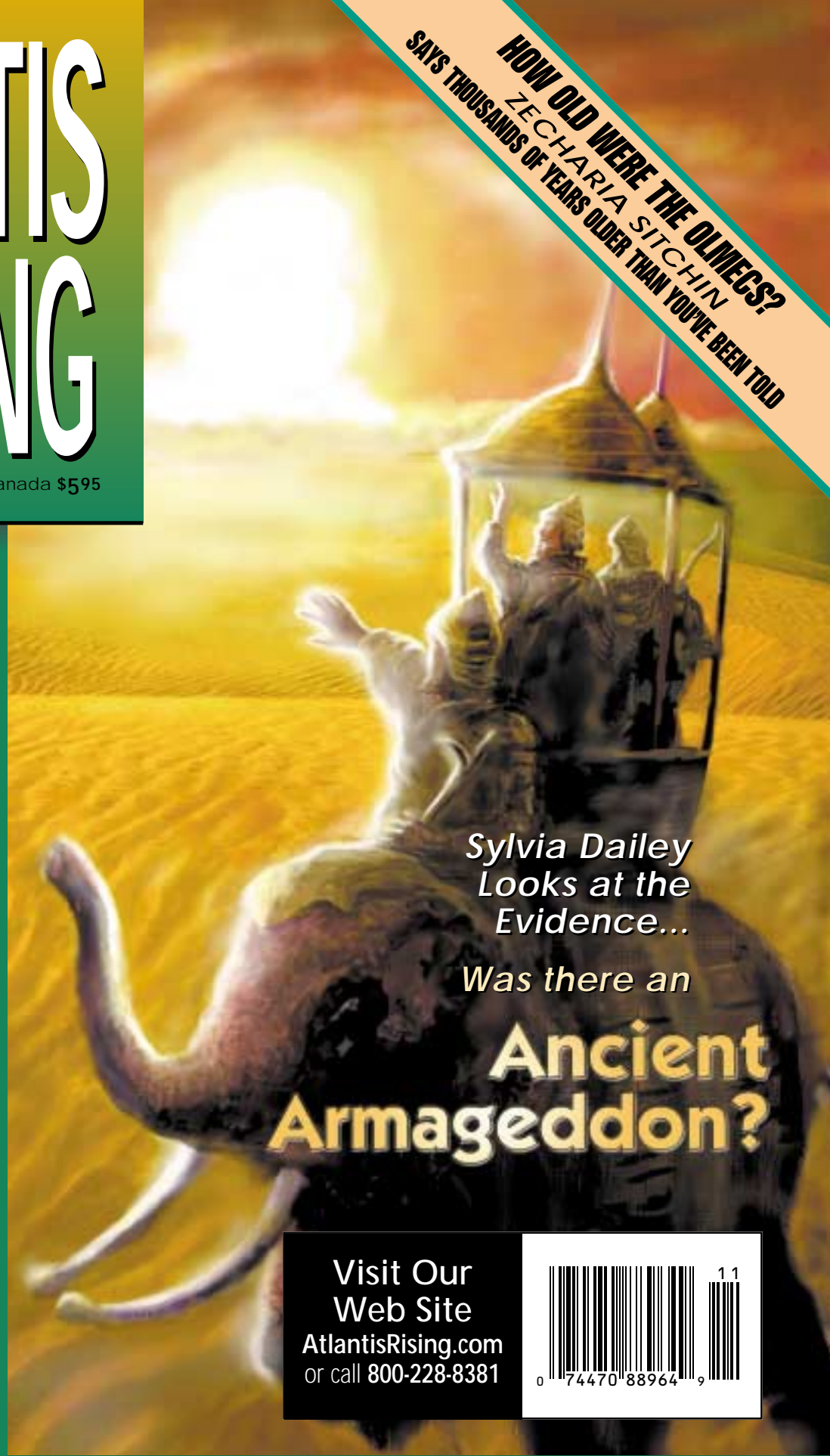

HOW OLD WERE THE OLMECS?
ZECHARIA SITCHIN
SAYS THOUSANDS OF YEARS OLDER THAN YOU'VE BEEN TOLD

Sylvia Dailey Looks at the Evidence...

Was there an

Ancient Armageddon?

Visit Our
Web Site
AtlantisRising.com
or call 800-228-8381



EXPLORATIONS IN NON LOCAL CONSCIOUSNESS
A Jeane Manning Interview with Russell Targ

TERRA ENTERTAINMENT

Messages from Heaven

Many believe Mary has come to turn us back to God, while others insist that these events are fabrications. Does the Bible anticipate apparitions, signs and wonders in the last days? How might the apparition of Mary and other paranormal events affect the world?

TE-2069 • \$19.95

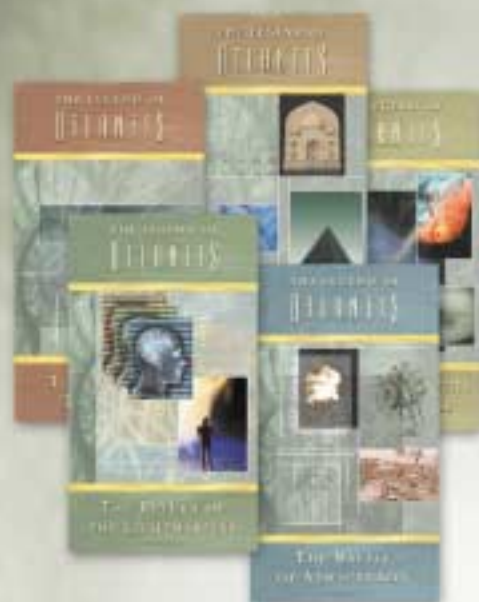

Atlantis Series

The legend tells how thousands of years ago human civilization developed and reached its peak at the time of Atlantis. This exciting documentary series reveals for the first time the secrets of Atlantis, the secret knowledge of the Atlantean Brotherhood, secret of the pyramids, the Sphinx, evidence of a world-network of tunnels under Earth, and the role of Atlantean knowledge in our present day.

TE-2029 • \$99.95



UFO: Secrets of the Third Reich

Amongst its nefarious activities, the Third Reich was deeply involved with the occult. With the empowerment of the Third Reich came a slew of secret societies, such as the Templars, the Thule, the Vril, and the SS. This video reveals all.

TE-2038 • \$24.95

Alien Enigma

Stranger than fiction, Alien Enigma opens up the bizarre and baffling mysteries behind the alien presence on earth. This stunning documentary is a bold new interpretation that combines ancient esoteric knowledge with the latest theories of time-space reality.

TE-2047 • \$24.95



To order any product or request a catalog:

CALL TOLL FREE

1.877.78.TERRA

or
visit us online
www.shopterra.com

12335 Santa Monica Blvd # 300
Los Angeles, CA 90025

ATLANTIS RISING

ANCIENT MYSTERIES

FUTURE SCIENCE

UNEXPLAINED ANOMALIES

NEW AGE ADVENTURE

PUBLISHER & EDITOR
J. Douglas Kenyon

CONTRIBUTORS
Anthony B. Austin
Christine Barrere
John Chambers
David Childress
Sylvia Dailey
Christopher Dunn
Beverly Jaegers
Len Kasten

Cynthia Logan
Jeane Manning
Dr. Joseph Ray
Rob Resetar
Hilly Rose
Greg Taylor

COVER ART
Tom Miller

ATLANTIS RISING
published bi-monthly
Write PO Box 441,
Livingston, MT 59047
COPYRIGHT 2001 by
ATLANTIS RISING
No part of this
publication may be
reproduced without
written permission from
the publisher.

ADVERTISING RATES
Please call 406-222-0875
or 800-228-8381. Direct all
ad copy to PO Box 441,
Livingston, MT 59047.
Publisher reserves the
right to accept only
advertising deemed
appropriate to the
publication in subject
matter and presentation.

DISTRIBUTION:
magazine racks,
subscriptions, direct
promotional mailing
and the internet.
Subscription price is
\$24.95 (6 issues).

Number 26

CONTENTS

LETTERS 6

EARLY RAYS 10

HILLY ROSE 17

THE DAILY GRAIL

The Internet's Best Alternative
Science Site Now in Print **19**



THE LAST HOURS OF THE KURSK

Remote Viewers Go Where TV Cameras Cannot **23**

WERE THE PYRAMIDS POURED?

Chris Dunn Takes a Look at a Controversial Theory **24**

EDEN IN ARMENIA

Reader Sleuthing for the Cradle of Civilization **26**

A CONVERSATION WITH JOHN MACK

Deeper New Insight into UFO Abduction **30**

HOW OLD WERE THE OLMECS?

Very Old Indeed, Says Zecharia Sitchin? **32**

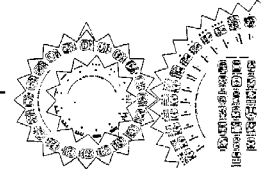

THE PRIEST AND HIS TIME MACHINE

Were the Authorities Trying to Keep Us in the Dark? **34**



THE METALS OF THE GODS

David Hatcher Childress on the Advanced
Ancient Sciences of Metallurgy **39**

ANCIENT ARMAGEDDON

Did the Ancients Use Atomic Weapons? **42**

THE VIVAXIS CONNECTION

Can Your Connection with Mother Earth Heal You? **45**

NONLOCAL CONSCIOUSNESS

Jeane Manning Talks to Russell Targ **46**

ASTROLOGY 48

BOOKS 51

RECORDINGS 56

Order
BOOKS VIDEOS
& MORE
See Our Catalog
Page 74



ANCIENT EGYPTIAN CATALOG
MUSEUM QUALITY STATUARY

cultured basalt
SELKET, 8 1/2" - \$49
ANUBIS BOX,
7 1/4" x 6 1/2" W - \$72
SEKHMET 10" - \$69



SCARVES
100% polyester,
34" square
in black, navy,
red, burgundy,
royal blue, or
turquoise - \$39



FINE WOVEN THROWS
100% cotton,
reversible design
52" x 72"
Isis (shown)
or Basta Cat - \$56
specify gold/black
or purple/lavender



Visa - Mastercard - Shipping \$5
FREE Egyptian Gift with each order!

Helen McCrea
150 INYO COURT
SAN BRUNO, CA 94066
650-873-8793
FAX 650-873-9493

A WORD FROM THE PUBLISHER

Atlantis, we believe, has been—in a manner of speaking—'rising' for some time, but this year we expect it to do so at a much faster clip. Since its inception in November of 1994, *Atlantis Rising*—the magazine—has been published four times a year. This year we intend to increase that to six. Read into that what you will, but the plain truth is, we are accelerating our production process and that is good news for all of our loyal readers, if not for the planet.



To those who never quite figured out how our previous schedule worked and called regularly to wonder about the whereabouts of their latest issue, this should be welcome news indeed. It certainly means more meaty, cutting-edge reporting on the most interesting stories of our times, It means more pictures, more interviews and book reviews and, of course, more truth about ancient mysteries, alternative science, unexplained anomalies and much, much more. We're excited and we hope you are too, but don't forget that your subscription will run out a little sooner now. Anyway, we will not forget to remind you.

Producing *Atlantis Rising* at a faster clip has always been our intention, but it has taken a few years to get things sufficiently aligned to make it possible. This does not mean, however, that bi-monthly publication is our ultimate goal. We eagerly look forward to the day when we will be operating on a monthly, or even weekly basis. Hopefully, we will also be able to increase our page count and improve the publication in many other ways. All of these things will be possible when the magazine is read by enough people. Getting from here to there is a step-by-step process which, even at this faster pace, takes time to unfold. Toward that end we hope to maintain the loyal support of readers like you, and, to hope also that you will re-double your efforts to spread the word to those among your friends who have not yet discovered us. Thus, we believe, the day of that future perfected *Atlantis Rising*, which we all envision, will be hastened.

Whatever the future may hold, you need wait no longer for the extraordinary contents of this very issue, and if you see the current offering as a harbinger of things to come you will not be much mistaken. In the following pages, you will not only find interviews with John Mack and Russell Targ, you will read the latest from Zecharia Sitchin and Christopher Dunn, you will examine the evidence for advanced metalurgy in the prehistoric past and you will investigate the case for atomic holocaust at the end of the last ice age and much more. All of which is but the tip of the proverbial iceberg—or should we say, the first emergence above the ocean of dry land from a drowned continent?

At any rate, we trust you get our drift.

Publisher

KHEMET TOURS



Enjoy the splendors of **ANCIENT EGYPT**, and absorb its lasting message, which was meant for all of us to behold. Share in addition the multi-cultural experience of Islam, Nubia, and the Copts. Partake in a journey, that offers a well balanced blend of life-learning, exploration, and many other enjoyable activities.

March 16 - April 1,
May 18 - June 3, 2001

at a cost of **\$2940** (dbl.occ.)

Included are the transatlantic and four flights in Egypt, five-star hotel accommodations, two meals daily, introductory literature and lectures, guided sight-seeing on and off the beaten track, all transportation, luggage handling, and much more. For a free brochure contact:

Dr. Herta Jogland / Khemet Tours
(304) 346-2240, FAX (304) 346-3530
Registration ends four weeks before departure

Giza, Cairo, Memphis, Sakkara, Aswan, Abu Simbel, Philae, Kalabsha, Kom Ombo, Edfu, Luxor, Abydos, Dendera, Abusir, Dahshur.

ANCIENT MYSTERIES • FUTURE
SCIENCE • THE UNEXPLAINED

BACK ISSUES!

Get them while they last!

- 1 John Anthony West • James Redfield • Atri Sapat • Advanced Ancient Technology **Sold Out**\$70
- 2 Cold Fusion • Richard Hoagland • P.M.H. Atwater • Prophecies for Year 2000\$70
- 3 Peter Tompkins • Ancient ETs • Dead Sea Scrolls & New Age Jesus • Magical Journeys\$35
- 4 Graham Hancock • Dannon Brinkley • Hall of Records • Impossible Inventions\$30
- 5 Zecharia Sitchin • Robert Bauval • Out of Place Artifacts • Secret History\$25
- 6 Michael Cremo • Gordon Michael Scallion • Evolution vs. Creation • Cosmic Collisions\$22
- 7 Rand Flem-Ath • John Anthony West • Crystal Planet • Anti-Gravity & the Third Reich (A FEW NOW AVAILABLE)\$50
- 8 Edgar Mitchell • Where Was Atlantis • The Sphinx Scandal • Age of the Pyramid\$20
- 9 Colin Wilson • Beneath the Martian Rock • Moira Timms • Goddess Runes\$18
- 10 Psychic Spooks • Crystal Skulls • Ancient Aircraft • UFO Coverup • Paul Roberts\$16
- 11 Chinese Pyramids • Jurassic Art • Pattern from the Other Side • Carbon 14 Problems\$15
- 12 John Michell • Cataclysm 9500 BC • Edgar Cayce on Atlantis • Coral Castle Mystery\$14
- 13 Japan's Undersea Ruins • Secret Tunneling in Great Pyramid • Tesla/Marconi Connection • Stan Tenen • Alan Alford\$13
- 14 Crop Circles • Problems with Darwin • Rand Flem-Ath on Atlantis • Richard Noone • Ostrander & Schroeder\$12
- 15 Giza Hall of Records • Nan Madol • Zecharia Sitchin • Psychics and Science • Christiane Northrup • Victor Hugo\$10
- 16 Politics of New Energy • Giza Power Plant • Art Bell • Future Memory • Back Engineering Roswell\$8
- 17 Nostradamus Code • Clairvoyants on the Case • Atlantis in America • Alan Alford • Moira Timms\$6
- 18 The Electric Universe • Linda Moulton Howe • Joe McMoneagle • Caribbean Stargate • Premonitions of Disaster\$6
- 19 John Anthony West • Robert Schoch • The Power of Water • Cold Fusion Proven • Isaac Newton and the Occult\$6
- 20 Robert Bauval on Alexandria • Jean Houston • Secrecy and New Energy • Templar Treasure in America?\$6
- 21 Christopher Dunn • Shakespeare Riddle • Revisionists of Third Kind • James Redfield on Shambhala • Hilly Rose\$6
- 22 Quick Frozen Mammoths • Politics of Anti-Gravity • Shape Power • Richard Noone • Moira Timms • Mahabharata\$6
- 23 Ralph Ellis on Bent Pyramid • Robert Schoch • Dead Mars, Dying Earth? • Biological Apocalypse? Lynn Grabhorn\$6
- 24 The Pulsar Mystery (Paul LaViolette) • Chris Dunn at the Petrie Museum • The Hydrogen Revolution • Houdini's Last Escape\$6
- 25 The Pulsar Mystery (Paul LaViolette) • Chris Dunn at the Petrie Museum • The Hydrogen Revolution • Houdini's Last Escape\$6

Atlantis Rising • P.O. Box 441 • Livingston, Mt 59047
Credit Card Orders Call 800-228-8381
 Prices include S/H and based on available supplies
 at press time. Subject to change without notice.



The Secrets of Creation

To get your comments into this space, write: Atlantis Rising, P.O. Box 441, Livingston, MT 59047, or e-mail us at Darsi@atlantisrising.com. Writing a brief and clear letter remains the best way to get your views to our readership.

Geometric Face Off

The following comments regarding the article *The Human Face Of Sacred Geometry*, by Charles R. Henry, are not intended to dissuade *Atlantis Rising* from publishing new research efforts in the future; but while the goal of offering the reader's insight through the presentation of new research is laudable. The results, in this case, are painful.

First, the evidence. (I'm assuming these photographs represent the best evidence of his achievements.) Figure 3 does look vaguely anthropomorphic: it looks like a Muppet, the one of the grumpy old man. All I can make out on Figure 2 is possibly a pair of human lips. Figure 4—which looks like a design by the artist, H.R. Gieger—has a few vague human faces, which brings up a point: the human body utilizes bilateral symmetry in its design; any other thing exhibiting bilateral symmetry, from inkblots to cloud patterns, will of necessity produce human-like forms from time to time. Figure 6, a confluence of all the objects being reflected can be taken, at a point, as a face; however, notice that all the reflected elements that comprise it are separate symmetrical objects, and that to isolate it as a face your mind has to employ its pattern recognition software, which immediately excludes contiguous imagery that doesn't look like a face, and, using a bilateral seam as the organizing point, groups several independent images into a whole. This is because the mind acts as a filter and an organizer of visual data; it takes patterns and compares them against previously known images and looks for a match; thus, several independent objects, seen from a distance, become a face.

The natural tendency of the mind to perform in this fashion has been recognized for generations and exploited by numerous artists. It was used to particularly good effect by Salvador Dali. The matches between the photographs and human faces, such as they are, are



not evidence of some heretofore unknown design process in nature, but of the psychological manipulations of the human mind in its never-ending attempt to derive meaning and recognition out of the background jumble of information we are constantly exposed to. To wit: the photos are interesting from an artistic standpoint, particularly figure 4, but demonstrate nothing about sacred geometry.

A word about the author's attempt to cloak his process in the wisdom of the ancients, i.e., his arbitrary linkage of his process to the Kabbalah. Here, his attempted rationalization rapidly eclipses logic. Since the Kabbalah is involved with the idea of creation and employs spheres, and the author's methods involve creation (of human faces—not even whole heads) and uses spheres, then, ipso facto, enough of a connection exists to link the two. That done, he then twists the diagram of the Tree Of Life into two 3D pyramidal sections of five spheres each—effectively obscuring the fact that on the TOL the ten spheres are arranged according to a series of three upper triads and Malkuth (material world/earth) at the bottom. That's a lot of effort to go to, but, hey, if you're developing a keyhole theory, anything goes, even rendering apart and rearranging the Tree Of Life.

So, are we to assume that the creative powers of the universe sat around

The matches between the photographs and human faces, such as they are, are not evidence of some heretofore unknown design process in nature, but of the psychological manipulations of the human mind in its never-ending attempt to derive meaning and recognition out of the background jumble of information we are constantly exposed to.

endlessly manipulating a series of spheres until they saw them make a reflection they liked on a two dimensional surface, then said, "Hey, let's blow that 2D image we just made from reflections of 3D spheres on 2D surfaces back into the third dimension, then design a body to go with it and we're in business!"

I am being flippant, of course, but this is the essence of what we're asked to consider. Nature, from a design standpoint, does use particular mathematical ratios associated with sacred geometry (the phi ratio and its harmonics, for example) to create three dimensional forms. What sense would it make—a poor utilization of energy, indeed—to start with a 3D template (the spheres), reflect them on a 2D surface (the reflecting surface the author photographs) and then use that 2D image as a basis for going back into the third dimension to create form. None. Creation is this manner has more affinity with bureaucratic ineptitude and design by committee than with the concise mathematical logic and beautiful geometric interplay so creatively employed by Nature.

*Michael R. Warren
Union City, GA*

I found *The Human Face of Sacred Geometry* very interesting especially in the "construction", the creation" (?), of

Continued on Page 9

www.MINDTOMIND.com

2 PAGES PER SECOND... MINIMUM!

by Thornton Massie Tice

My son came to me one night while I was working on the computer and asked, "Poppa, can you find something about speed reading on the Internet for me? I'd like to learn it." "Sure" I replied, and within a few seconds I had a page of speed reading courses that were offered. One particular one caught my eye. It read, "25,000 words per minute minimum!" I chose that one and clicked on it and up popped a presentation by a company named Subliminal Dynamics and Brain Management®. I read through their web page at "www.subdyn.com" and discovered that they don't actually teach speed-reading. They teach "Mental Photography®".

Photographic Memory

I became very excited because they seem to offer a lost piece of my life experience that I thought that I would be able to have from the time that I was a child.

When I was a youngster my father was a newspaper editor. At night he would sit down and literally flip through the pages of a book and sometimes hand the book to me and say, "Here Son, read me a sentence from anywhere in the book. I thought that it was some kind of trick, but he could do it even if I went around the corner into the hallway. Dad explained to me that he had a **photographic memory**.

My Mother recently told me, Dad would bring a stack of books to bed each night and read them all in just a few minutes. She asked, "Thornton, what are you doing?" He stopped flipping the pages, looked at her and said, "Reading." "No one can read that fast," she replied. "It's impossible!" He assured her that he could read that fast and offered her the stack of books that he had just devoured and asked her to choose a book and he would tell her about it. I thought Dad would always be there for me and never asked him to teach me how this was done. I definitely intended to though. My father died when I was twenty years old. I have lamented my not having gotten an understanding of his photographic memory.

So when I read the information on Subliminal Dynamics and their course on "Mental Photography®" I shouted, "Eureka!" This is something that I want to make sure that all of my children have."

A NEW way to Learn How to Learn

Richard Welch, CEO and Founder says that everyone is born with the ability to learn by Mental Photography® and in fact everyone uses it to learn everything - until we are about five years old. That is when we enter the public school system and learn the Rote-Memory System of reading. I believe that is when the brakes are put on our learning process and we move from potential genius into slow thinkers that store most educational matter into our short-term memory rather than our **long-term memory**. Learning by Mental Photography® places matter into our long-term memory. That's why my father could remember every word in the dictionary without "memorizing" the words. He simply set them to memory by Mentally Photographing® them a page at a time. Excitedly, I e-mailed Subliminal Dynamics and Brain Management® and told them I wanted to take my whole

family to America to learn this wonderful ability that my father had.

Brain Management – Powerful!

"Subliminal Dynamics and Brain Management® Seminar is truly a **Whole Life Enhancement Course**, and it is **powerful!** Mental Photography® is used for much more than assimilating information. It is the life force of the course. Mental Photography® is the Key for making this all work. As a Brain Management® student, you experience Mental Photography®, take tests, etc.... then they teach you ways in which to recall that information when you 'need' it." It is a very specific method of directing information into the long-term memory.

Mental Photography bypasses Dyslexia!

During the class, adults and children with **dyslexia** quickly overcame that problem, and after the seminar function with excellence and confidence in education and writing, and any other challenge.

My father stacked degrees during his lifetime. He sort of collected them. After all, all he had to do was photograph the books into his long-term memory and take the exams. Now I will be able to learn what was natural to me as a child, and take that ability with me to easily further my education. Why not!? Others are doing it!

Kids that relearn this ability are able to graduate from school years ahead of the other kids - with very high grades. They begin taking college courses as youngsters. Learning becomes first nature, as there is an end to the tedium of **memorizing and cramming** material into the short-term memory only to loose it within a few days or weeks.

There are several languages that I want for my children and myself to know. By Mentally Photographing® the cross language dictionaries of any desired **language** into the long-term memory, it is possible to know the whole vocabulary of a language in as much time as it takes to flip the pages of the book. Then by Mentally Photographing® a study book for that language, the only thing you're short, is knowing the sound of the language. For that you could listen to tapes or speak with someone who speaks that particular language.

Limitless Brainpower

The **possibilities are limitless** with this kind of **brainpower**. For years scientists have told us that we use less than ten percent of our brain's capacity. Now I have found the way back into the other ninety percent and intend to see that my wife and children learn it and move through life with the confidence that will be theirs with this command of powerful intelligence that is naturally available for all of our children. This reinforces my personal long held understanding that all of mankind is born genius and then robbed of it by being taught an unnatural method of learning - "reading". Mental Photography® puts real meaning to the phrase, "**Be all that you can be!**"

Empower Yourself!

Successful Brain Management® and Mental Photography® Seminars have been taught throughout the world and offer **FREE REFRESHERS FOR LIFE**. They are committed to the success of their students.

Welcome to Tomorrow®

Are you happy with your life? If yes, DO NOT READ THIS!

Others only sound like
The **ORIGINAL** and
most **AMAZING**
Brain Management® &
Mental Photography® .
Training available worldwide!

WORLDWIDE Students
are telling others

"Excellent, Clear Training"
Narelle S. - Psychologist

"The Value is \$10,000.00+!"
Michael M. - Consultant

"Feels like reaching the top of the mountain!"
Samuel F. - Accountant

"Best course & most natural learning method ever!"
Quentin J. - Businessman

"The door into the future!"
Gary D. - Clinical Nurse

"I went from near failing grades to getting A's on my tests in 2 weeks - with **NO STRESS!**"
Glen S. - University Student

"It worked!" - MAXIM Magazine

Brain Management®

**Sound Impossible?
Get Happy!
Enroll NOW!!**

Wealth, Health, Success, Goals,
Business, Intuition, Memory, Stress-Free
Learning, Concentration, Intuition,
Solutions, Direction, Relationships,
Gold Medal Performance!

**25 YEARS of Research
& Development makes it
EASY for you to find out
what makes you
HAPPY!**

"The Consultants"

19744 E. Union Drive, Suite 100
Aurora, CO 80015

 (303)627-9132

 (303)627-8793

SEMINARS AND HOME STUDY COURSES
email: subdyn@subdyn.com
l-net: <http://www.subdyn.com>

**Now,
There
Is No
Need
to Wait
so Long
to See**

ATLANTIS RISING

Bi-Monthly

We're Accelerating from Four to Six Issues a Year

*Learn what the mainstream press
and the tabloids won't tell you...
THE TRUTH about ancient mysteries,
alternative science, unexplained
anomalies and much, much more...*

*Presented in Credible,
Colorful, Profusely
Illustrated Articles
Featuring Today's
Top Researchers like:*

- John Anthony West
- Graham Hancock
- Robert Bauval
- Zecharia Sitchin
- Richard Hoagland
- David Hatcher Childress
- Jeane Manning
- and many others...

**BUY ONE
SUBSCRIPTION
(either 6 or
12 issues)
Get a Second
FREE!**

*(The second must live
at least a 100 miles away)*

Read **ATLANTIS RISING** Bi-Monthly

\$4⁹⁵ on newsstands

SUBSCRIBE NOW 6 issues for **\$24⁹⁵** 12 issues **\$40⁰⁰**

800-228-8381

P.O. Box 441 • Livingston, MT 59047

See what you've been missing in our on-line archives

www.AtlantisRising.com



LETTERS

Continued from page 6

a "pyramid" in Figure 1. Three radii of the small circle equals one radius of the large circle. A line that crosses a circle through the center of that circle runs through the diameter at two places at a RIGHT ANGLE to that diameter. "It" appears that the two intersections of the two small diameters define both the "base line" and the "apex" of a certain "pyramid", a certain "triangle". And with the "apex" being at a point in which two sides of that "pyramid" crosses the diameter of the two small circles respectfully at RIGHT ANGLES. And for a four-sided pyramid, this would also be true for the other two sides. In the drawing of a "triangle", the "base line" is drawn horizontally through the bottom intersection of two circles of equal diameters. In the drawing of the two sides of the "triangle", the "apex" is the top intersection of two circles which continue on through the center respectfully of the two circles. How do I show if this "apex" is at the point of the faces of the "pyramid" being at RIGHT ANGLES respectfully to the two diameters of the two circles? They may not be at RIGHT ANGLES? Using the "Star of David" of two equilateral "triangles" of 180 degrees each, being equal to 360 degrees of a circle, is the easy way to prove all of our trigonometry. The "Star of David" also in its past had a "crystal" connotation.

Tommy Webb
Ovalo, TX

Big Bang Demise

Just finished reading *Atlantis Rising* #25 and once again your magazine provided some great information. 'Is the Big Bang Dead' article caught my eye. What maverick astronomer Halton Arp says makes plenty of sense. One of my own theories is that perhaps in the vastness of space there were several Big Bangs and if this is true, there may be many various universes. Where we think our own universe ends at the edge of the quasars, then perhaps we travel further and find nothingness. Then as we continue on with our journey we discover another line of quasars and a new universe to explore.

On another note, CNN News mentioned on how Pioneer 10 was launched in 1972 and keeps going like the Everready Rabbit. It was remarkable that it survived the asteroid belt too. As a Star Trek fanatic and claiming myself as a Captain to my own created Federation Starship, the USS Rogue, I recall a Star Trek movie, in which they showed the Pioneer 10 becoming god-like, because it had survived so long gathering up so much knowledge I wonder?

Paul Dale Roberts
Elk Grove, CA

Although I do not agree with all of Halton Arp's conclusions, the article definitely gives people food for thought. His observations do not necessarily lead to the conclusion that the Big Bang is dead, only that creation is an ongoing process.

There may be many various universes. Where we think our own universe ends at the edge of the quasars, then perhaps we travel further and find nothingness. Then as we continue on with our journey we discover another line of quasars and a new universe to explore.

As Mr. Arp points out, the spectrum emitted by a galaxy is dependent upon its age, so the standard red shift measuring rod is inaccurate. To understand better how this situation can exist, and the universe yet have its origin from a point, as assumed in the Big

Bang Theory, I would suggest that Mr. Arp, and other interested subscribers, read *Sacred Science* by Norman Paulsen. It is a very clear, yet eye-opening presentation of the cosmology of the universe.

Joe Belton
Buellton, CA

Ma'mun's Agenda

RE: 'The Enigma of Ma'mun's Tunnel'

The Ka'aba is just a box. The choice of Black Granite is solely an aesthetic choice.

By revelation to the prophet inside are the foundation stones of Abraham's altar on which he was to sacrifice his son.

Thus mankind's first unconditional contract with Allah is marked/honored.

Thank you for a wondrous record of our amazing curiosity. The sphinx weathering pattern changes everything.

Please, as and when you can, pay attention to the emerging archaeology of the Black Sea Ice age refuge/Noah's flood developments.

Tom Davison
Mountain View, CA



THE SECRET TEACHINGS

THE BOOK THAT SEPARATES
FACT FROM FICTION

Just Out and Already Hailed
As 'a Masterpiece of Research'

Writers enjoy spinning yarns about everything from the Egyptians, "Lost Atlantis," the Sphinx, and the incredible Nephilim, to Adam and Eve, the Beast, the Scarlet Woman, the Books of Enoch, Genesis, and Revelation, and the Eleusinian Mysteries.

These and many other riddles from antiquity are of the greatest interest to everyone. But unless you know how the stories *originated*, you can never know what to believe, and unknowledgeable writers will continue to beguile their readers with foolish theories and fairy tales that have nothing to do with history or with facts.

The Egyptian Mystery Teachers knew the facts, however. They said: "By this book he shall know the secrets of *that which happened in the beginning*. No one else has ever known this mystical book. It has not been spoken by men. No eye hath deciphered it, no ear hath heard it. This is a true Mystery, unknown anywhere to those who are uninitiated."

That secret "book" was deciphered a hundred years ago by the British author and genius, Gerald Massey, but his works could not be comprehended by the scholars of his day. Now Massey's discoveries have been published in *The Secret Teachings*, a unique book whose time has come at last.

622 pp., 200 illustrations and 1,200 references. Indexed. Casebound, cloth cover, gold-foil stamped. \$35, plus \$4 S.&H. in the U.S. Order toll-free: (877) 312-1768. Or visit <http://www.secret-teachings.com>.



BETHEL PUBLISHERS
15 East Putnam Avenue, Suite 403
Greenwich, Connecticut 06830

Has The Mystery Of Egypt Intrigued You?

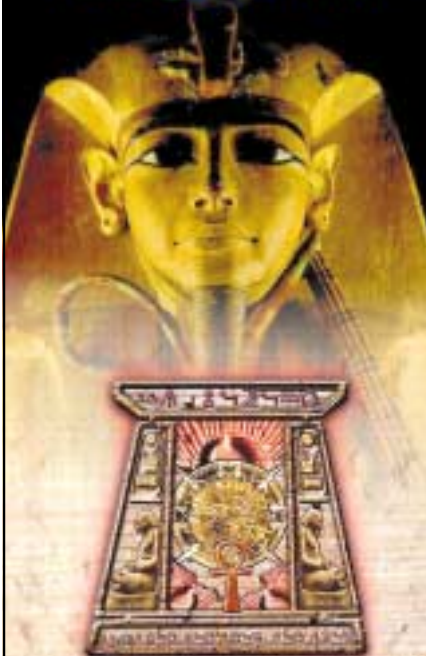

1. What are the secrets of Egypt?
2. Who built the pyramids?
3. Do you have guardian angels?
4. Were the Egyptians from beyond the stars?
5. How do you prepare for death?
6. Egypt, the Bible and Koran
7. Jesus found in Egypt
8. Did Mars have the first Egyptian civilization?
9. The Freemasonic Order and Egypt
10. U.F.O.'s and Egypt
11. What is the true symbolism behind the obelisk needle?
12. Can angels guide you to health and wealth?

You can find the answers to these most mystifying questions that have gone unanswered for thousands of years. Enter the pylon and be a part of the most sought after and authentic order in the world ever... The Ancient Egyptian Order where truth and facts are waiting for you. Visit our website at: www.egyptianmysteries.com or email us at: Egypt3x3@aol.com

EARLY RAYS

New Evidence for Much Earlier Dawn of Egyptian Civilization, Presented to American Geologists

In November while most of the media was apparently looking the other way, another blow was struck against the orthodox paradigm for the dawn of civilization on Earth, with momentous implications concerning questions of our true origins.

At the annual conference of the Geological Society of America in Reno, Nevada, before a packed audience of nearly 500 professional geologists, Boston University professor Dr. Robert Schoch

delivered in about 15 minutes a paper coauthored with John Anthony West entitled "Further Evidence Supporting a Pre-2500 B.C. Date for the Great Sphinx of Giza, Egypt." Except for two irate Egyptologists who tried to shout down the proceedings, the audience seemed favorably disposed to the ideas presented.

The paper represented Schoch and West's response to challenges from the Egyptological establishment to sensational claims by the pair at the 1991 GSA event that water-weathered features of the Sphinx proved it was substantially older than allowed by orthodox history. Critics had argued that, no matter what the geological evidence might show, there was no archaeological context to support the West/Schoch thesis.

At Reno-Schoch made several points including recitation of recently completed studies which support his work and the listing of corroborating facts from a number of Egyptian sites. As stated in the conference abstract: "These include other monuments at Giza and elsewhere exhibiting water-weathering features preserved beneath or within Old Kingdom (ca. 2575-2150 B.C.) repair campaigns and structures (for example, Tomb of Queen Khentkaus at Giza; a weathered chamber protected within the Red [North] Pyramid at Dahshur). Deeply weathered shaft tombs adjacent to or near much less weathered Third Dynasty (ca. 2600 B.C.) shafts at Saqqara provide further possible evidence for previously unsuspected large-scale pre-Third Dynasty



Ancient water-weathered stone beneath old kingdom masonry in the so-called "burial" chamber of Dahshur's Red pyramid.

cultural projects in Egypt."

The primary argument of the noisy detractors can be paraphrased to the effect that thousands of Egyptologists have studied the Sphinx for hundreds of years and it can't possibly be older than the traditional date. (Incidentally though, in point of fact, only a handful of people, including Schoch and West, have actually studied the Sphinx closely.) Other points made by the hecklers were of comparable merit.

Almost no media attended the ensuing press conference, a circumstance which may have owed more to distractions posed by events in the wake of the U.S. presidential election than to a lack of interest in the subject. If so, it certainly was not the first time that discoveries of great importance have been overshadowed by events which ultimately proved to be of less consequence. ■

DON'T FREAK OUT

WE HAVE WHAT YOU NEED

Primal Defense
Green Teas
Ginsengs
Rooibos
Hyperzine A

FREE NEWSLETTER

eco-safe bioactive cleaners for septic tanks and odor control

Always a money back guarantee

SOLUTIONS UNLIMITED, RR 1 BX 60 DEPT. A
SHARON SPRINGS, NY 13459 (518) 284 2055

www.flushitsolutions.com

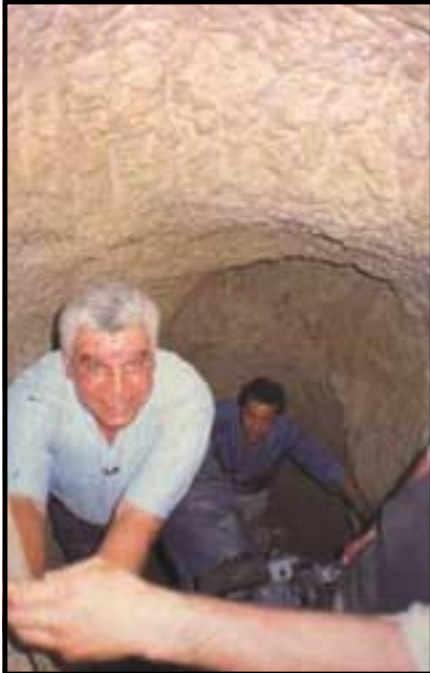

Al Ahnam

Dr. Hawass emerges from a recent dig

With his credibility already under fire from some quarters, and his need for favorable American publicity at an all-time high, Egyptian antiquities director Zahi Hawass certainly didn't need accusations from an American television producer of "bamboozling" the public. For the news documentary *Inside Edition*, however, Hawass may have been too tempting a target.

At issue was his claim on the Fox Television special "Opening the Lost Tombs: Live from Egypt" in the Spring of 1999 that he was actually discovering a mummy for the first time on live television—a claim which he admitted on camera to *Inside Edition* was false. He had actually discovered the mummy a month earlier and was, he said, simply staging the event for Fox and its millions of viewers. *Inside Edition* ran the exposé in November, along with some pointed remarks

Inside Edition Challenges Truthfulness of Giza's Boss

about the Fox network's propensity for questionable "reality" fare such as "Who Wants to Marry a Multi-Millionaire?" and "The World's Scariest Police Shootouts." When pressed on deception in its mummy show Fox placed the responsibility on Hawass's shoulders, "The Government of the Republic of Egypt maintained control over the archaeological digs and Dr. Hawass and his team were responsible for the excavation and preparation of all finds featured on the special."

The negative publicity cannot be welcome, especially at a time when Hawass's critics have questioned his role in blocking a previously agreed ground-penetrating radar survey of the Giza plain (set for May, 2000) after confirming to the press that it was indeed happening. Not surprisingly, such incidents have reminded some of other promised explorations which have—as some put it—'mysteriously' failed to materialize, such as his publicly stated intention to investigate the so-called Gantenbrink door in the Great Pyramid around the Spring Equinox of 2000 (A.R.E. summer conference 1999). And such incidents, it has been suggested, cannot help but cast doubt on other public pronouncements such as his insistence in 1999, despite considerable evidence to the contrary, that no secret tunneling was going on in the Great Pyramid. In a climate rife with suspicion, critics speculate, the recovery of his lost credibility could pose a formidable challenge to Hawass. ■

WEB Site
come.to/artpark
 Click on Curt's Page
 Email
artpark@win.bright.net
715-269-5112

Cell Phone Radiation Protection Guard

Protect yourself from harmful cell phone radiation with the patented **Cell/Wave Guard™** for only \$19.95.

Recent scientific research has associated cell phone use with a wide array of harmful health effects. Why take the risk when you don't have to?

To order go to our website at www.cellwaveguard.com or call us toll-free at **1-866-603-3265**.

ACADEMY OF REMOTE VIEWING HOME TRAINING PACKAGE

- As seen on TV shows *Sightings* and *Real X-Files*. Develop astounding intuition by learning to operate at the deep Theta level of brain.
- Learn revolutionary mind-expansion technology used by CIA and foreign intelligence services for 20 years. Become a psychic spy.
- View any target in space/time. Receive and process information from the collective unconscious (Delta level of mind). Forecast your probable future.
- Master Remote Mind Influencing (subconscious). Taught by former operative. Proven results. \$97.50 – 800-299-1974

VISIT: WWW.PROBABLEFUTURE.COM

FINALLY, THE STORIES OF SUPPRESSED INVENTIONS

Preceding every great advance and many of the setbacks in our history, the geniuses of both light and darkness, have battled for the hearts and minds of the rest of us. But, despite the stubborn resistance of those committed to the primitive notions of earlier ages, the outrageous impossibilities of one generation continue to become the revolutionary breakthroughs of the next and the basic necessities of the future.

Still... in the 20th century, while the Marconi's...the Henry Ford's...the Thomas Edison's have succeeded in capturing most of the attention, others with technological prowess bordering on the miraculous, strangely, have gone unnoticed. Men with names like Tesla, Moray, Rife, Russell and Schauberger, laboring in almost complete obscurity, and achieving almost incomprehensible miracles—free energy, anti-gravity, transmutation of the elements, physical rejuvenation and more—were yet largely rejected, ridiculed and despised by the scientific establishment of their day. But now, a few decades later, a new breed of inventors, scientists and researchers is making rapid, if yet unpublicised, strides toward unraveling the astonishing secrets of those unsung giants who preceded them. Today, many of these new technological magicians find themselves on the threshold of breakthroughs, still believed, by many, to be the stuff of hallucination.

Clash of the Geniuses—one hour VHS **\$19⁹⁵** + \$4.95 S&H

Visa or MC **800-228-8381**

Atlantis Rising • P.O. Box 441 • Livingston, MT 59047

AtlantisRising.com



Cold Fusion



Wireless Power Transmission



Inventor Paramahansa Tewari



Rejuvenation Technology



Nazi Anti-Gravity



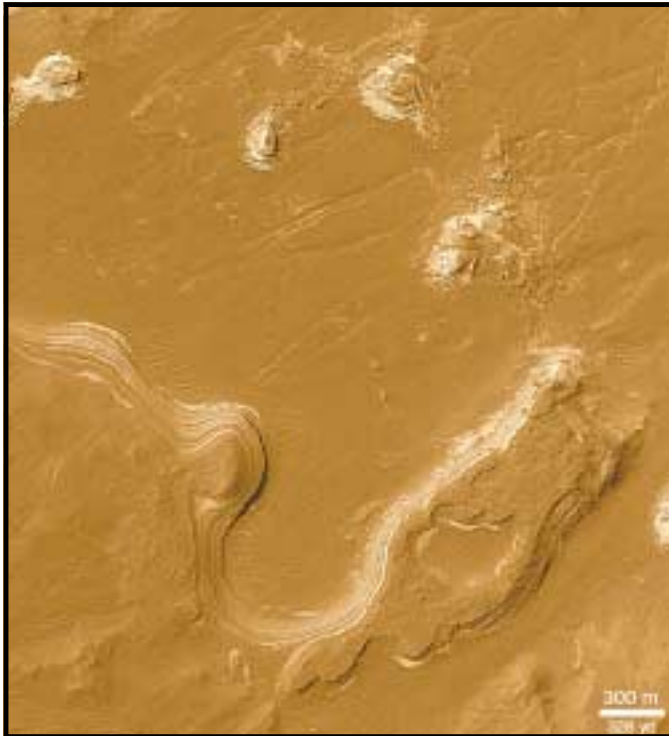

EARLY RAYS

Martian Pictures Show Ancient Lake Bed Strata

Ancient Martian real estate may have been well stocked with lake front property. The evidence is increasing that not only did the Red planet have water—and not all that long ago (geologically speaking)—but it may very well once have been a veritable land of lakes. Such a land could possibly have supported life which might have evolved to levels once considered impossible.

Recent photos from the Mars Global Surveyor reveal layers of Earth-like sedimentary rock not unlike that found in the Grand Canyon. Scientists think such rocks might harbor fossils of ancient Martian life. Reported in the *Journal Science*, the new findings do much to make the case that Mars may have once been warm, wet and hospitable to life.

A mission to Mars set for this spring could turn up topographical data and lateral photos to strengthen the case, while a mission planned for 2005 is being planned with the new information well in mind. ■

Photo from the Mars Global Surveyor reveals sedimentary strata in the Holden Crater. (NASA)

Uri Geller Sues Pokemon Maker for Stealing and Distorting His Identity

Some might like to see themselves immortalized in a Pokemon cartoon. Uri Geller is not one of them and he is suing in U.S. District court in Los Angeles to make his point.

The Israeli psychic, famous for spoon bending and other super mental feats, has taken umbrage at a character in the Pokemon game and media series called "Yun-Geller" who carries a spoon and uses psychic mind waves to give his victims bad headaches. If Geller and his lawyer Marshall Grossman have their way, Nintendo, the Japanese game maker responsible for the Pokemon industry, will be the one with the headache. They are being sued for hundreds of millions of dollars. "Nintendo turned me into an evil, occult Pokemon character," Geller said. "Nintendo stole my identity by using my name and my signature image of a bent spoon."

And that is not all. Grossman says there are anti-semitic overtones. The Pokemon monster is depicted with lightning bolts reminiscent of the Nazi SS symbol. ■



Aqua Dholavira (courtesy of the Archaeological Survey of India).

Water System Resets Clock for Ancient Tech

Aqua Dholavira, a recently discovered reservoir in India's western state of Gujarat, has been dated to the middle of the third millennium B.C. well before the period generally assigned to such advanced engineering.

The sophisticated water management system, complete with giant reservoirs (the largest measuring 263 feet by 39 feet and 24 feet deep), was capable of holding more than 325,000 cubic yards of water. Aqua Dholavira was discovered by a team under the auspices of the Archaeological Survey of India led by R.S. Bisht. The same area suffers from water shortages today, causing Bisht to wonder if the ancients could control water so effectively, why can't modern day engineers do the same? ■

WHAT IS YOUR IDEA OF EXCITEMENT?

Defrosting the fridge? Waxing your car? Watching TV talk shows?

OR DO YOU PREFER...

- Hacking your way through impenetrable jungle searching for lost Incan cities?
- Diving to explore the mysterious underwater ruins in the Pacific?
- Paddling an unexplored Amazon tributary in search of the legendary El Dorado?
- Trekking across shifting sands in search of the lost city of the Kalahari?
- Climbing the high Himalayas to visit a remote Tibetan monastery?
- Discovering previously unknown animal species or living dinosaurs?



If this is excitement to you, you should be a member of the *World Explorers Club*. We are dedicated to the exploration, discovery, understanding, and preservation of the mysteries of man and nature. We go where few have been before and dare to challenge traditional academic dogma in our effort to learn the truth. Join us on our journey of discovery!

As a member of the *World Explorers Club*, you will: • Be eligible to participate in our expeditions. • Read fascinating accounts of adventure and exploration in our magazine *World Explorer*. • Have access to the *World Explorers Club* headquarters and its huge archives • Receive discounts on *World Explorers Club* merchandise, travel-related services, and books from the *Explorers Library* - a unique selection of books (many rare imports) you won't find anywhere else.

MEMBERSHIP CHOICES

- **Regular:** US\$25. Canada US\$35. All other foreign US\$40. Includes: Subscription to the *World Explorer*. **FREE** 35-word classified ad, *Explorers Library* Member discounts, and Expedition Discounts.
- **Couple:** US\$35. Canada US\$40. Foreign US\$45.
- **Contributing:** US\$50: All above + *World Explorers Club* T-Shirt.
- **Supporting:** US\$80: All above, a free book from the *Explorers Library* and expedition highlights video.



World Explorers Club
 PO Box 99, Kempton IL
 60946 USA • Phone: 815-253-9000 • Fax: 815-253-9077
<http://www.azstarnet.com/~aup>
Credit cards welcome An
 Adventures Unlimited Press publication

**Discount
 New
 Age**

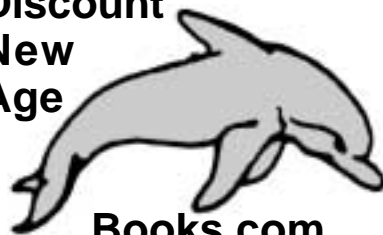

Books.com

**Select from 100s
 of Titles
 and Order on Line**

- *Alternative Health/Healing*
- *Astrology/Tarot*
- *Health/Nutrition*
- *Home/Environment*
- *Metaphysical*
- *Psychology*
- *Religion*
- *Self-Help*
- *Spirituality*
- *Wicca/Occult*

70% OFF RETAIL

<http://discountnewagebooks.com>

Attention Webmasters



Now you can leverage your buying and selling power into extra income for your site.

A revolutionary new approach offers unprecedented rewards.

PerLeadNetwork.com

the newest and best affiliate network on the net!

Why are we the best? Because we allow advertisers to get their money's worth and because we pay affiliates the highest fees!

Paying a set fee on per lead or per sale basis allows advertisers to pay only for real results and not for advertising campaigns that may or may not work!

Advertisers: Sign up now—Free—No Setup Fees! No Monthly Fees!
 Affiliates: Join the network NOW! No Setup Fees! No Monthly Fees!

Affiliates earn more money with PerLeadNetwork.com! Why should a webmaster only get paid pennies per click when those same clicks could otherwise result in much more income? We serve the banners right to your website, you don't have to be constantly uploading and downloading banners to place on your website, just sign up with us, choose the offer or offers you wish to participate in and we'll serve the banners right to your website. Place the html code once, that's it!

Our system works best for everyone! Advertisers pay only for qualified leads, webmasters get paid what their website traffic is worth!

WE HAVE THE SAFEST METHOD ON THE NET!



Mysterious Manuscript Keeps Its Secrets from the Code Breakers

Code breakers of all stripes are gathering in cyberspace like flies to honey to tackle a mysterious 361-year-old document. So far, though, according to *USA Today*, the so-called *Voynich Manuscript* has proven to be beyond solution. Its origins shrouded in mystery—currently locked away in Yale’s Beinecke Rare Book and Manuscript library—the lavishly illustrated work is where only certified scholars can study it. Nevertheless, a couple of enthusiasts have brought the project to the web. Visitors at www.yoynich.nu as well as at web.bham.ac.uk/G.Landini/evmt/evmt.htm can read

the research of German mathematician Rene Zandbergen and Englishman Gabriel Landini and others. Zandbergen and Landini have created a font for the book’s strange characters but have, of course, not succeeded in deciphering it.

Most students of the book’s colorful illustrations—full of herbs, stars, and tiny people—cannot help but feel there must be meaning here, perhaps to do with astrology or alchemy... But what?

“I think (the manuscript) was written by someone whose mental processes we can’t really fathom.” Says Zandbergen. ■

Sasquatch Makes Big Impression but Debunkers Continue to Scoff

Idaho State University researchers claim to have found the body imprint of a sasquatch or Bigfoot near Mount Adams in Washington State. The purported imprint in a mud wallow, from which a casting has been made, reveals a large hairy forearm, buttock, thigh and heel, all roughly 50 percent bigger than a 6-foot tall man. According to physical anthropologist Jeffrey Meldrum, the creature was lying on its side as it reached into the center of the wallow for apples and nectarines used as bait. Meldrum acknowledges that the imprint is not definitive proof for the existence of Bigfoot, but nevertheless calls it “significant and compelling new evidence”.

The professional debunker community is predictably skeptical and pre-

pared for rhetorical battle. Michael Shermer, publisher of *Skeptical Magazine* and author of *Why People Believe Weird Things*, is quoted in the *Denver Post* “If you believe Bigfoot, it’s most likely you believe in Loch Ness and the lost continent of Atlantis.” According to Shermer, Bigfoot advocates “are tapping into an open-mindedness that borders on gullibility” and have only anecdotal evidence to go on.

In the meantime, several scientists who have examined Meldrum’s cast agree that it cannot be attributed to any known animal. ■

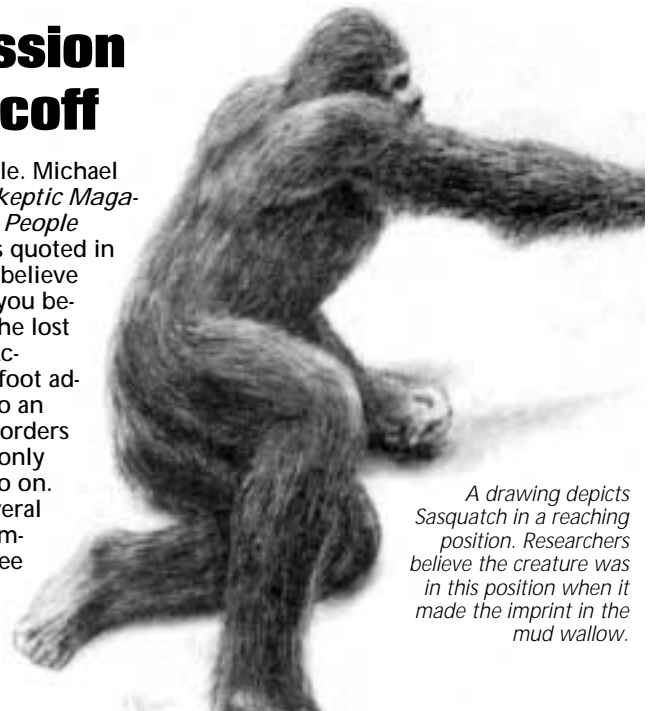

A drawing depicts Sasquatch in a reaching position. Researchers believe the creature was in this position when it made the imprint in the mud wallow.



Rachel's Destiny AS WRITTEN IN THE STARS *The Feminine Side of the Bible*

by Julie Bresciani Ph.D. is a compelling new version of the Old Testament story of Jacob, as seen through the eyes of his beloved Rachel. Written by a certified Jungian analyst and Astrologer as a healing for our culture, this story of brother against brother, and sister against sister explores the spiritual/political battle between good and evil which has sealed the warlike fate of Earth. Learn about Earth’s secret past, the ancient sisterhood of Seerers from the star system Sirius, who were the Bible Mothers of the the heroes of the Bible, and who the angels of the Bible really were.

“I loved this book! What Marian Zimmer Bradley did for the Arthurian legends in the *MISTS OF AVALON*, Julie Bresciani has done for the Old Testament story of Rachel.” — Dr. Ron Grant • Jungian Analyst

“This is a remarkable book! It answered the questions I had been asking my entire life.”
Maggie Callaway • CEO of the Callaway Group

“I felt illuminated from reading this book” — Oscar Lubow • Merchant Banker

Hardcover 440p \$25, S&H incl. ISBN 0-9657958-0-2 *Rachel's Destiny* AS WRITTEN IN THE STARS is available through

ASTRAEA CIARA PUBLISHING CO. 52 Rio Grande St. • Durango, CO 81301

Available at www.Amazon.com • Visit our website at RachelsDestiny.com



ATLANTIS RISING

MAGAZINE PRESENTS



During a late summer weekend during the first year of the millennium some of today's most provocative scientists, writers and researchers gathered in splendid natural surroundings on the banks of the Yellowstone river to consider the evidence for and against impending Earth Changes—from pole shifts to eco-disasters, from cosmic collisions to interplanetary magnetic storms. During the conference, the gathered experts weighed carefully whether such events may have interrupted human history in the past and whether our ancient forebears, indeed, attempted to warn us of what we might have to fear if we are not able to learn from prior experience. The weekend also made news on Egypt and other fronts. If you were unable to attend, don't despair, because you can now own the tapes.



Now Available on AUDIO and VIDEO TAPE

Tape 1 Keynote address by Atlantis Rising Editor and publisher J. Douglas Kenyon. Researcher Michael Mandeville, "The Return of the Phoenix Trilogy" reexamining the prophecies of Edgar Cayce in Light of modern research.

Audio \$10.95 Video \$22.95

Tape 2 Rocket Scientist John Brandenburg and science writer Monica Rix Paxson, "Dead Mars Dying Earth," present evidence for the catastrophic destruction of an ancient Martian civilization and the possibility that Earth might experience a similar fate.

Audio \$10.95 Video \$22.95

Tape 3 Comparative mythologist Dave Talbott, "The Saturn Myth," and physicist Wallace Thornhill "The Electric Universe" use computer animation to argue that the ancients witnessed the catastrophic collision of planetary bodies including Earth and left the record in myths and legends.

Audio \$10.95 Video \$22.95

Tape 4 Dr. Paul LaViolette scientist and author ("Earth Under Fire", "Beyond the Big Bang") presents evidence from astronomy, geology, and ancient starlore pointing to a Galactic cosmic ray / solar flare catastrophe behind legends of a global deluge.



Audio \$10.95 Video \$22.95



Tape 5 Dr. Robert Schoch geologist, tenured professor at Boston University and author ("Voices of the Rocks"), presents evidence in support of the newly reconsidered theories of "catastrophism" and previews arguments prepared for the Geological Society of America supporting the great age of the Sphinx of Egypt.

Audio \$10.95 Video \$22.95



Tape 6 John Anthony West noted Egyptologist and author ("Serpent in the Sky"), offers his unique insight into the hopeful meaning of ancient myths of death and resurrection as expressed in the symbolist school of Egyptology. West also takes on the establishment on his case for a much more ancient Egyptian order.

Audio \$10.95 Video \$22.95

Tape 7 Frank Joseph editor of "The Ancient American" and author of several books ("The Pyramids of Rock Lake"), provides dramatic new evidence for the catastrophic destruction of forgotten civilizations in the Pacific.

Audio \$10.95 Video \$22.95

Tape 8 Moira Timms author ("Beyond Prophecies and Predictions") and expert on the wisdom teachings of the ancient Egyptians and the Mayans, offers a new approach to ancient prophecy.

Audio \$10.95 Video \$22.95

Tape 9 Panel Discussion Part 1. Michael Mandeville, Monica Rix Paxson, Frank Joseph, Dr. Paul LaViolette, Dr. Robert Schoch, John Anthony West, David Talbott, Wallace Thornhill, and Moira Timms.

Audio \$10.95 Video \$22.95

Tape 10 Panel Discussion Part 2. Michael Mandeville, Monica Rix Paxson, Frank Joseph, Dr. Paul LaViolette, Dr. Robert Schoch, John Anthony West, David Talbott, Wallace Thornhill, and Moira Timms.

Audio \$10.95 Video \$22.95

ENTIRE TEN-TAPE SET Audio \$95 Video \$199

S&H \$4.95 for one tape or set. Add \$2 for each additional

Send Check or M.O. to ATLANTIS RISING • P.O. Box 441 • LIVINGSTON, MT 59047 or call 800-228-8381



COMMENT

Hilly Rose OFF MIKE

THE END IS COMING! THE END IS COMING!

No need to laugh at those comic strip characters carrying signs proclaiming the end of the world, I am convinced they are absolutely correct. The end of the world is indeed coming. What I cannot tell you is when. I am also not sure what will cause the end, but be assured it is coming—probably not in your lifetime, but, then again, don't be too sure.

"Scientific" findings are being reported in increasing numbers to show that the world is much older than we thought. Carbon dating, DNA testing and other means are used to positively determine the age of fossil finds. Yesterday's theories go out the window, and what was scientific proof is replaced by newer methods and theories.

It reminds me of the apocryphal story about the young boy visiting an anthropology museum when he sees a dinosaur model. He asks the docent how old the dinosaur was and the docent replies, "One hundred million and ten years old." The little boy looks amazed and asks how she can be so definite about the extra ten years. The docent explains that when she started giving lectures, they told her the dinosaur was one hundred million years old...and that was ten years ago!

I do believe that many of our scientists use the same logic as the docent. Twice in the past year, NASA has predicted catastrophic collisions between the earth and an asteroid. In both cases, astronomers discovered new information within 24 hours that proved NASA incorrect and forced them to revise their estimates. Relax! The September 16, 2030 NASA prediction has now been revised to the year 2071. And the first incident has been called off altogether. Of course, if you read the daily papers, you know there have been a number of near misses in 2000. Asteroids have escaped the notice of astronomer's telescopes and come from unknown areas in the sky.

Geologists studying meteorites found on Antarctica and the Libyan desert have discovered evidence of a monstrous cataclysm nearly 3.9 billion years ago when both the moon and the earth were bombarded from outer space with a force so powerful that it turned the earth hot, changed the atmosphere with vaporized silica rocks and boiled away the surface of the oceans. The scientists say that at least 17,000 asteroids or comet heads, perhaps as large as 600 miles in di-

ameter, came in one brief spasm. Barbara Cohen of the University of Tennessee says that since the moon also got bombarded, pieces came to earth. This strongly effected the future of life on our planet and could have destroyed the very earliest life that existed, or it brought to our planet the first organic molecules that served as the beginnings of life here.

I am sure that our docent in the museum would be astounded by the 3.9-million-year figure and add another ten years. She would probably be confounded by the scientific finding that this rock storm destroyed all life...or set the stage for life.

At an American Geophysical Union symposium in San Francisco at the end of 2000, scientists discussed the Walter Alvarez (University of California at Berkeley) theory that the dinosaurs became extinct from a nuclear winter of cold and darkness that lasted for thousands of years, caused by the impact of an asteroid or comet. These scientists said they are now confident that the Yucatan, Mexico crater was more than 125 miles wide and spread glassy matter on the ocean bottom 1000 miles east.

Geophysicist Gail Christeson (University of Texas at Austin) used seismic echoes from air gun shots within the crater and determined that the extraterrestrial impact dug more than 20 miles down to the very bottom of the earth's crust. The impact created a huge fire storm sending up a towering plume of molten rock, dust, ash and killing gases which made the earth almost uninhabitable for 70 percent of plant and animal life. This is not the same event noted above. This one is dated at 65 million years ago—quite recent times, comparatively.

A different cataclysm occurred between the two, 1.8 billion years ago at Sudbury, Ontario.

This one was 100 miles wide, according to Virgil Sharpton of the University of Alaska. I am sure that as time goes on and scientific tools improve, we will find any number of collisions that destroyed life as we know it.

But what is life as we know it? Until recently, we egoists decided that intelligence is a recent development. Not so, according to Doug Broadfield at the Mount Sinai School of Medicine in New York. They analyzed the nearly complete cranium of a female who lived 400,000 years ago (give or take ten years). She had the capacity of speech, language and complex thought. Broadfield says this lady is from homo erectus, predecessor to homo sapiens, and may be the long sought missing link between the two.

We humans also believe that we are the only species with higher intelligence. Give some thought to this story from Saudi Arabia where there are 350,000 baboons in residence. A driver on the road between Mecca and Taif ran down a baboon and kept going. Not exactly a hit and run in our terms; yet, as reported by the *Los Angeles Times* last November,

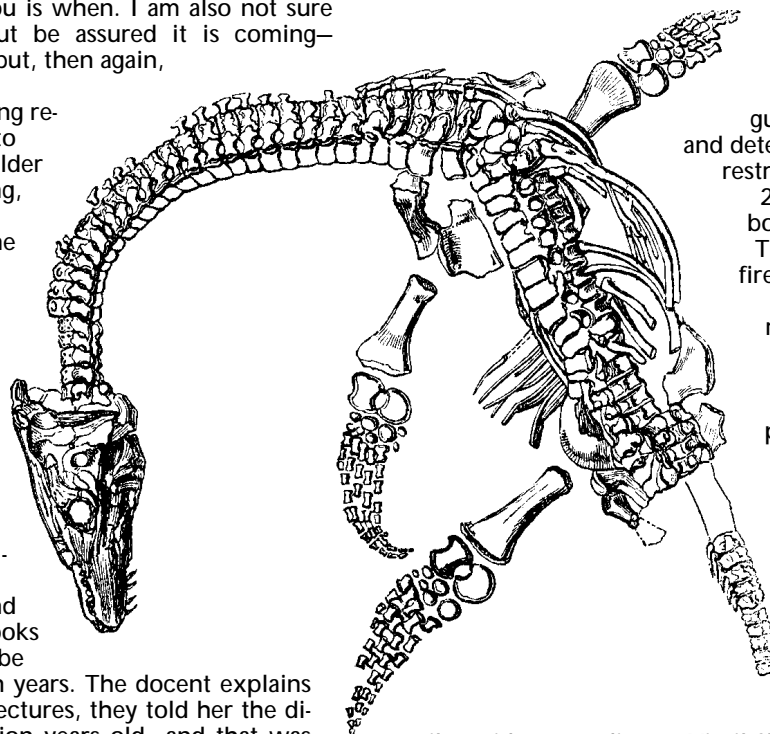

Continued on Page 58

Hilly Rose Is a Nationally Syndicated Radio Talk Show Host Specializing in the Paranormal

SEE OUR GREAT 8-PAGE CATALOG SECTION BEGINNING ON PAGE 74

Number 26 • ATLANTIS RISING 17

Discover the Mysterious

"The most beautiful thing we can experience is the mysterious. It is the source of all true art and science." – Albert Einstein.



Sacred Science, book and video by Norman Paulsen, reveal the art and

science of prayer and meditation, and take you on a journey to discover the mystery behind all of creation: the Being of Light that is the source of the cosmic forces that shape the universe. Discover for yourself the template upon which the structures of antiquity were built. Use it to build your own sacred temple, right within your own body.



SACRED SCIENCE
Meditation,
Transformation,
Illumination

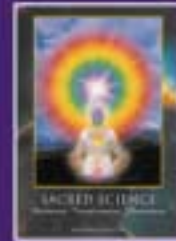

Books and video available:
Solar Logos Foundation,
P.O. Box 2008, Dept. AR,
Buellton, CA 93427
1-888-689-0352
e-mail: solarlogos@utech.net
visit our website at:
www.solarlogosfoundation.org

New Scientific Breakthrough
proven to reverse
biological aging through
metabolic changes

Safer and more effective than HGH!



Stephen Cherniske, M.Sc.
Life Extension Specialist, President,
Oasis Wellness Network

Call toll free at 1-866-576-7441 or e-mail us at miracle@ida.net for a free tape!

Start Growing Younger Today

GET THE FACTS

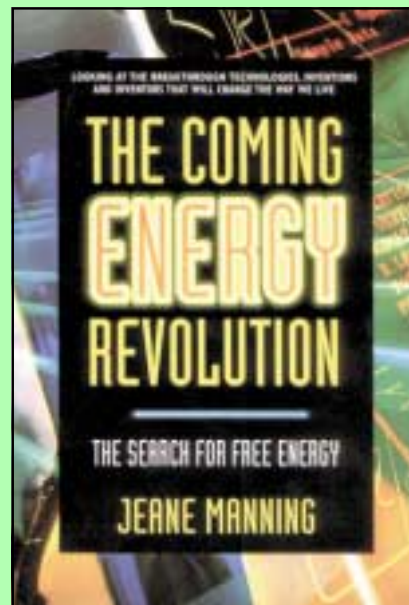

Now reporter Jeane Manning has broken through the wall of cover-up and misinformation about the most exciting story of our time. From Cold Fusion to zero-point energy, from Tesla to Tom Bearden, Jeane reports the hard-to-get facts unavailable from any other source.

Avery Publishing • 230 pages • Tr. pap. • Profusely illustrated • \$12⁹⁵

TO ORDER CALL 800-228-8381 or see PAGE 81



click through to [The Daily Grail](http://www.DailyGrail.com) from [Atlantis Rising.com](http://AtlantisRising.com)

When the Gods Came Down

The author of *Gods of the New Millennium* has found a new explanation for many ancient mysteries. THE DAILY GRAIL recently interviewed writer Alan Alford. Here are some excerpts (you can read the entire interview on-line):

TDG: Could you provide an overview, for those readers not familiar with you or your work, on how you came to be a professional author on alternative history?

AA: Certainly. At around the age of 20, I read one of Erich Von Daniken's books in which he suggested that the 'gods' who came down from Heaven to Earth in ancient mythology were astronauts from another planet. Being open-minded and having no particular religious convictions, I was fascinated by this possibility—especially because the 'gods' were often depicted in human-like form.

I was thus inspired to take an interest in history and religion—subjects which had bored me to death at school—and I began to realize that there were numerous anomalies in the

human past which had been overlooked by modern scholars; for example, the origins of Homo sapiens, the origin of ancient civilisations and their amazing scientific knowledge; and above all, the legends of the gods who came down to Earth, created mankind and granted it the gifts of civilization. Von Daniken's theory seemed to supply a unique explanation for all of these anomalies.

Later, in 1989, I went to a conference in America and discovered the works of an American writer Zecharia Sitchin. Sitchin had taken the ancient astronaut theory further than Von Daniken and his thesis—written in a more scholarly style—totally captivated me. During the next few years, I became well acquainted with the Sitchin material and began to see how his thesis might be updated and



Alan Alford

improved in certain aspects. In addition I felt that Sitchin's work had been unfairly overlooked in the 'alternative history' boom which had hit the UK in the early 1990s and I was motivated to try and redress the balance and bring Sitchin's work to the attention of the UK public (the UK public had been starved of ancient astronaut books since the early 1980s).

In 1995, I began working in my spare time on a book entitled *Gods of the New Millennium: Scientific Proof of Flesh and Blood Gods*, which I self-published in 1996 (I had taken the view that the subject matter was far too sensitive for a mainstream publisher). But then, to my great surprise, I was approached by Hodder & Stoughton Publishers, who made me an offer for the sales rights to *Gods*, along with an advance which would cover the research and writing of two further books. It was at this point that I decided to turn my

Continued on Page 20

SEE OUR GREAT 8-PAGE CATALOG SECTION BEGINNING ON PAGE 74

iNEWS

INFORMATIVE LINKS
worth following from
DailyGrail.com

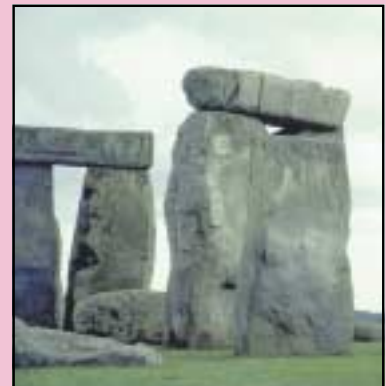

• **Latest New Scientist is ready for viewing—an absolute truckload of interesting stories including this one on modern changes to Stonehenge.**

<http://www.newscientist.com/dailynews/news.jsp?id=ns9999310>

• **Australians challenge 'out of Africa' theory with (the brilliantly named IMO) Mungo Man.**

http://abcnews.go.com/sections/scitech/DailyNews/evolution_outofafrica_010109.html

• **NASA goes for long-shot landing on asteroid.**

http://abcnews.go.com/sections/scitech/DailyNews/asteroid_landing010109.html

• **Galilee's receding waters reveal Stone Age camp.**

<http://news.nationalgeographic.com/news/2001/01/0102galilee.html>

• **Old story doing new rounds—Ancient Egyptian prosthetic toe.**

http://news.bbc.co.uk/hi/english/health/newsid_1081000/1081368.stm

Continued on Page 20

• **An article mainly about CSICOP, but with interesting updates on SRI members and Uri Geller.**

<http://www.sfgate.com/cgi-bin/article.cgi?file=/chronicle/archive/2001/01/08/MN185307.DTL>

• **Heyerdahl thinks the US might have been settled by Viking tax exiles.**

http://www.foxnews.com/scitech/010801/times_vikings.sml



• **Pipeline found between galaxies.**

<http://www.sciam.com/news/011001/1.html>

• **Very handy resource—the space schedule for 2001 (not a monolith in sight!).**

http://www.space.com/news/space_schedule_010104.html

• **The 'end of the beginning' in genome research.**

http://news.bbc.co.uk/hi/english/sci/tech/newsid_1100000/1100726.stm

• **Music and singing are not particularly human apparently. If you ever hear me sing, you'll understand much better...**

http://news.bbc.co.uk/hi/english/sci/tech/newsid_1102000/1102190.stm

Continued on Facing Page



back permanently on the chartered accountancy profession and become a full-time researcher and writer.

The rest, as they say, is history—or should that be 'alternative history'?! In 1998 Hodders published my sequel, specifically on ancient Egypt, entitled *The Phoenix Solution: Secrets of a Lost*

Civilisation. It was in this book that I began to realize that the theory of the gods advanced in my first book was seriously flawed.

During the last two years, further research has convinced me that the 'gods' who came down from Heaven to Earth were definitely not ancient astronauts but meteorite-and-flood gods from an exploded planet (whether real or mythical). The results of this study are written up in my new book, published April 2000, entitled *When The Gods Came Down: The Catastrophic Roots of Religion Revealed*.

TDG: *I have to say I enjoyed the book and I think in the future it will be seen to have made a contribution to advancing our knowledge of ourselves. There is no doubt that you are also quite original in your research. In looking at the fundamental approach of 'WTGCD' you have clearly separated science from mythology. Since, perhaps, 'Hamlet's Mill' to your own last work 'The Phoenix Solution', the approach has been to marry science and mythology together to demonstrate how advanced ancient civilisations were. In 'WTGCD' you see this as inappropriate. What value do you see in taking the science out of tackling the mythology of the ancients?*

AA: The originality of my work began with *The Phoenix Solution* in which I suggested that the ancient Egyptian religion was an 'exploded planet cult', with the Sun being only a visible symbol for the invisible (by definition) exploded planet. This was—both literally and metaphorically—a ground-breaking development.

The problem with *The Phoenix Solution* was that I followed the time-honored custom of mixing up mythology with science. Thus I fell into the trap of suggesting that if the ancient Egyptians had believed in exploded planets, then planets must have exploded and the ancients must have had a fantastic scientific capability—equivalent to 20th-century technology—in order to derive this conclusion (incidentally I never suggested that the ancients had actually witnessed a planetary explosion).

This caused a problem because my revolutionary decoding of the ancient Egyptian religion (an extremely strong part of the book, especially in view of my subsequent work) was seen to be intertwined with an equally revolutionary theory of science—Dr. Tom Van Flandern's 'exploded planets hypothesis'.

The problem here was not that Van Flandern's thesis was demonstrably wrong (far from it), but that his scientific thesis was—and still is—unproven. Many readers (prejudiced against the book, which threatened to upset a whole lot of applecarts) used this 'dubious science' as an excuse to treat the whole book with disdain.

Nevertheless, the mixture of science and mythology which appeared in *The Phoenix Solution* has served a useful purpose in highlighting a very real problem faced by all ancient wisdom researchers, namely, how should one judge the level of ancient science when modern scientific knowledge of the Earth and the solar system is in a constant state of flux? In other words, today's scientific knowledge will not be the same as tomorrow's scientific knowledge, so how can we possibly stand in judgment of the ancient science?

There is, of course, a much wider problem here, namely, a tendency for researchers to impose modern preconceptions on ancient art, architecture and literature. A classic example is the Von Danikenite tendency to interpret flying gods as pilots of aeronautical vehicles, and to interpret gods creating men and women 'in their own image' as astronaut-scientists using the technology of genetic engineering (I know the problem well, having fallen into the same trap myself).

Mainstream scholars are also guilty of making similar mistakes. Early Egyptologists, such as J.H. Breasted and E.A. Wallis Budge, imposed their modern Judaeo-Christian beliefs upon Egyptian Pyramid Texts dating from the era



Tom Van Flandern

2350 BC. Similarly, scholars from the 19th and early 20th centuries overlooked clear references to falling meteorites in ancient texts because they were uncomfortable with the concept of rocks falling out of the sky (one has only to think of the famous comment ascribed to Thomas Jefferson: "I would sooner believe that two Yankee professors lied, than that stones fell from the sky").

Today, 21st-century scholars are making the same mistakes all over again. The eminent astrophysicist Victor Clube, for example, has great difficulties with my proposal that 'God' was an exploded planet, but he is more than happy to suggest that 'God' was an exploding comet. This is because an exploding comet falls within the bounds of the science acceptable to Clube, whereas an exploding planet does not (at least not at the present time).

What is important, however, in the study of ancient mythology is not the current state of scientific knowledge—be it aeronautics, genetics or astrophysics—but rather the religious beliefs which were expressed by the ancients themselves. It is time, I suggest, that we listened to the ancients rather than listening to ourselves.

It is for precisely this reason that I have adopted the approach in *When The Gods Came Down* of taking modern science out of the equation as far as possible. To this end, I have avoided making any claim that planets really did

explode and that the ancients knew all about it, and have instead explained how the ancients might have derived their exploded planet hypothesis via a perfectly logical and intuitive cognitive process—based on their experiences with meteorites—regardless of whether a planet did or did not explode in actuality.

The value of taking this approach is that I can (and do) delve into all aspects of ancient and modern religious beliefs without falling foul of the hurdles erected by the modern astronomical consensus. Consequently, the 'exploded planet cult' theory which I presented in 'The Phoenix Solution', can now be recognized for what it is—a revolutionary breakthrough which opens up an entirely new vista on the origins of both ancient and modern religion.

TDG: *What perceptions do you have on the scientific thinking and capabilities of the ancients?*

AA: There is no doubt that the ancients were far more advanced scientifically than modern scholars would generally admit—although the modern picture of the ancients does seem to be changing rapidly. My impression is that the ancients did their 'science' using very different methods from those generally used today. I would suggest in particular that the ancients placed greater store in intuitive mental processes, allied in all likelihood with various metaphysical methods of data capture.

At the end of the day, we should not be dogmatic about whether the ancients were more or less advanced than ourselves. In some areas they might have been more advanced and in other areas less advanced. We must always remember that there is no law which says that the ancients had to be right about everything. And this is why we must treat their 'knowledge' of exploded planets with all due caution.

TDG: *Does your research indicate whether the catastrophic approach may be a universally occulted belief system? Thinking about commonalities worldwide in mythology—such as flood myths—I suspect your template could be successfully applied more widely. Does your research suggest a wider spread of the cataclysmic origins of man as a belief system—you did cite the Navajo, for example?*

AA: I am very aware of commonalities between the ancient Near East and other cultures of the ancient world, and I hope to explore these further in future books. I must be careful, however, not to jump to conclusions without a thorough study of the ancient culture under consideration. Having said that, I must say that the commonalities are not only wide ranging but also far more detailed than one might reasonably expect. I see trouble ahead... ■

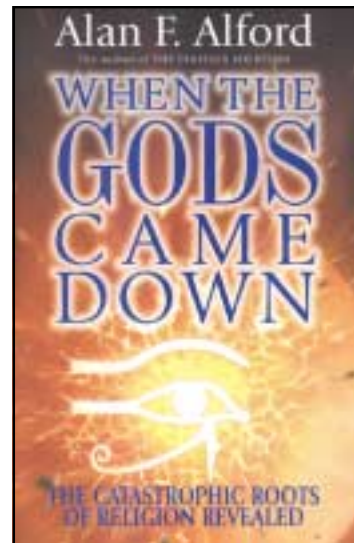

• **While we're at it, kissing isn't a genetic thing in humans either, just cultural. Going on my efforts, culture has a lot to answer for.**

<http://www.smh.com.au/news/012/29/text/world8.html>

• **Rock art reveals Pre-Dynastic Egypt.**

http://www.discovery.com/news/briefs/20001229/hi_hu_rockart.html

• **Egypt—pioneer in neuroscience.**

<http://www.egyptrevealed.com/051000-neuroscience.shtml>



• **Antarctic ice could hold ancient secrets.**

<http://www.usatoday.com/weather/antarc/sun/2001-01-07-old-ice.htm>

• **The Dark Ages may really have been dimmer.**

<http://www.sciencedaily.com/releases/2001/01/010102061812.htm>

• **New theories into what sank Ancient Egyptian cities.**

http://www.foxnews.com/scitech/121800/sunken_cities.sml

• **Templar Treasure hidden on Baltic Island? A piece on the latest Lincoln/Haagensen book.**

<http://my.netscape.com/mynsnews/story.tmpl?table=n&cat=50100&id=200012242132000296960>



English Sacred Sites

COULD THE SOURCE OF ENGLAND'S MYSTERY BE ATLANTIS?



A Vital New Video Could Hold the Answer...

Atlantis Rising Video presents *English Sacred Sites: The Atlantis Connection*.

The new 40-minute VHS program pulls together powerful evidence linking Stonehenge, Avebury, Glastonbury and many other English locations with an advanced ancient order now lost to history. Written and narrated by *Atlantis Rising* editor Doug Kenyon, the video is based primarily upon the discoveries of Cambridge-trained scholar and author John Michell. The program demonstrates how a mysterious network of perfectly straight tracks, laid out for hundreds of miles across the English landscape, proves the great advancement of pre-historic science. Michell's deep insight into the origins of English culture illuminates a startling new vision of the roots of civilization.

Beautiful on-location footage interspersed with spectacular 3-D animation and a great original music score make *English Sacred Sites*, not only moving and persuasive, but entertaining as well.

\$19.95 + s&h

To order call:

800-228-8381

or send a check or Money Order to:

Atlantis Rising • P.O. Box 441 • Livingston, MT 59047

See streaming video excerpts and order on-line at our web site at:

AtlantisRising.com

John Michell at Avebury



Ley Lines



Saint Michael's Tor



Kenyon and Busty Taylor



Ancient Observatory



Holy Grail

MONOATOMIC GOLD, RHODIUM, IRIIDIUM

Most Powerful Transformational Alchemy On Terra

ASCENSION

LONGEVITY

IMMUNE SYSTEM ENHANCEMENT

Monoatomic elements and many other unique powder and liquid formulations to initiate the biological reality of your ascension process.

- Activate your hypothalamus to secrete a new hormone preparing the body for a Higher Light Resonance
- Saturate your cellular structure with nascent Liquid Oxygen. Key to ascension.
- Literally drink in the language of Light the Sacred Geometry molecularly encoded in a natural solution that communicates directly on your cellular level, creating a photon cascade.
- Awaken "future" DNA codes and translate to RNA, the next step to full ascension.
- Strengthen your immune system with new Probiotic Formulations; powerfully anti-microbial
- Bio-superconductors that flow light with ease by increasing wall waves in your 3rd/4th dimensional bodies.

Free Catalogue, ASC, 8810 Gross Point Rd., Suite 74, Skokie, Illinois 60077 (847) 673-3431, asc@interaccess.com, www.asc-alchemy.com

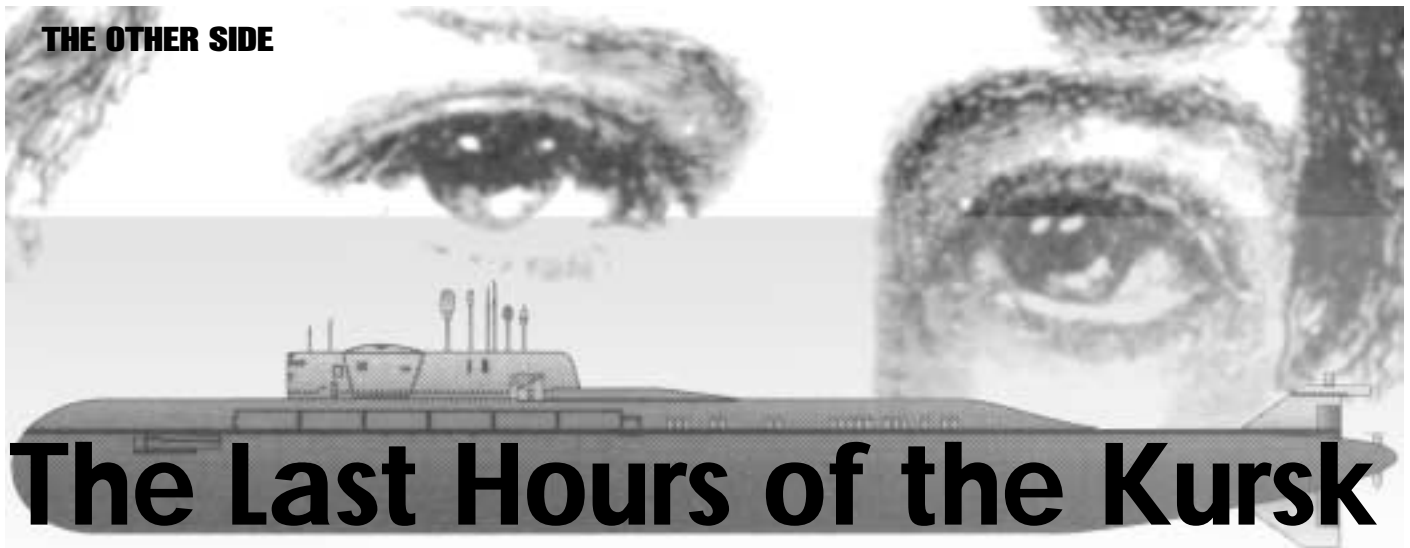

The Last Hours of the Kursk

While Most of Us Were Content to Wait for News of the Sub, a Group of American Remote Viewers Was Taking Action

Proudly carrying on deck an honor guard in snappy uniforms of dark blue, flags rippling in the stiff sea breeze, the five-year-old nuclear submarine 'boomer' Kursk, an Oscar II class vessel sailed proudly out into the Russian Sea. It was Aug. 10th and Kursk and her men were heading for a planned series of war game maneuvers with the Northern Fleet's cruisers, destroyers and one or more other 'nukes', in the cold waters of the Barents Sea.

Like Titanic, Kursk was fitted with such safeguards and strong hulls that she was considered 'unsinkable'.

Named for the region in southern Russia where Soviet troops had in 1943 attacked and routed Nazi Germany during the largest tank battle in history, Kursk was not only the pride of the fleet, but intended to be as deadly a weapon as the armored force which destroyed the Nazi advance.

Five hundred feet long, Kursk was an underwater missile launch pad, sleek flanks studded with two dozen missile solos, each holding a cruise-type missile capable of launching its payload into supersonic flight and aimed with deadly accuracy at such targets as battleships or carriers of an opposing fleet.

Kursk and her twelve sister 'boomers' were designed and partially completed during the waning days of the Cold War, which had ended a decade before her sailing; and designed to beef up a rapidly decaying naval force of older conventional submarines and surface vessels under Russian command.

Newly upgraded and refitted with a set of chemical torpedoes, Kursk formed a big part of the modern Russian fleet. These torpedoes were of a type, according to knowledgeable Intelligence sources, that had previously proven sometimes unstable. Their liquid fuel systems had been totally reworked, thus providing much more confidence in their performance. Sources say that Kursk also carried a number of 'tech reps' and weapons systems analysts whose job was the care and monitoring of these apparently much more reliable torpedoes. Fast and silent, they were of the Squall type.

Although now denied, some sources state that Kursk also carried a newer type of torpedo, capable of being launched skyward and then guided like 'smart bombs' toward their targets. These ultra-modern projectiles have never been proven to have been on the ill-fated Kursk, but it is both logical and likely that they were. This anti-submarine torpedo missile is fired not from a silo, but from an ordinary torpedo tube.

Accidental ignition of either type before clearing the tube would be disastrous to not only the torpedo firing room but to other such weapons stored nearby. Squall type torpedoes reach speeds of two hundred knots, but travel in a gas capsule to reduce friction from surrounding seawater, thus adding more perfect control.

'Rocket propelled' torpedoes carry the risk of such ignition of the first firing stage while still inside their compartment. Any leakage could virtually destroy anything within a radius of 350 feet, including the boomer's pressure hulls.

A letter written home from a Kursk

crew member mentioned that they were whiling away some time while watching 'rockets' being loaded into the boat.

A Sudden Silence

On August 11, Kursk had successfully fired a practice missile from a silo and Gennady Lyachin, Kursk's Commander, had been pleased with the result. Admiral Popov on the flagship *Peter the Great* had also been pleased and given the command to repeat the missile firing on the following day, Aug. 12.

After reporting a second success with this missile firing at about 1700 hours, Kursk was to have followed up by coming to periscope depth (less than 100 feet) and preparing to fire a salvo of torpedoes at the designated target. This sequence was verified by Norwegian and even U.S. 'watchers' who were doing their monitoring of the war games location from a safe distance of 20 miles or more away.

Unexpectedly, underwater explosions were detected by a Norwegian seismic Institute at 11:28 a.m. and 11:39 a.m. on the 12th. The second concussion was registered at 3.5 on the Richter earthquake scale. Frode Ringlaire, science adviser to the Institute reports "This is the single most powerful explosion we have ever registered in this area".

Following this there was a sudden silence over the entire fleet, and when Kursk's skipper failed to report results of his torpedo salvo to *Peter the Great*, a stunned fleet feared the worst. Attempts began at Kursk's last known position. It was reported some hours later

Continued on Page 59



A modern construction crew pours concrete at a building site.

***In an Atlantis Rising Exclusive,
the Foremost Advocate of
Advanced Machining in
Ancient Egypt Challenges the
Arguments for Pouring as a
Source for Giant Stones***



Giant building blocks in the Great Pyramid and elsewhere continue to baffle modern scholars. The angled blocks shown weigh over 40 tons each.

The Polemics of Pouring

ANCIENT MYSTERIES

There are many theories about how the pyramids of Egypt were built. From bashing stones with stones, rubbing stones with copper and sand to pouring the stones with a cement-like geopolymer. In writing the *Giza Power Plant*, I presented an engineer's and machinist's view of some of these artifacts. From my experience in manufacturing, I explained the minimum requirements to produce such objects. I don't believe that magical human, or alien, attributes were responsible for what we see in Egypt, so it was only with hard facts based on the evidence that I concluded that a high level of technology was necessary to produce these ancient artifacts.

My interpretation of the artifacts is clearly in conflict with orthodox theories. The disagreement is based not just on the difficulty of cutting hard stone (such as granite, diorite and basalt), but also all the available evidence, particularly the precision of the stones and the geometry of their final shape. I don't have a problem with other theories as long as they are held to the same standard. They should explain how *all* the characteristics could be produced within the parameters, or constraints, that are inherent to the technology they propose.

Proponents of the conventional primitive method, as well as proponents of the even more daring and controversial theory that the stones were poured, have challenged my conclusions for lack of historical support. The historical evidence they refer to is the body of knowledge or understanding established by academic bodies. Some of these challenges have been professional and thoughtful, while some have been otherwise.

I am writing this in response to what I believe is an unfair attack on my work from Margaret Morris, the co-author in 1988 with French chemist Dr. Joseph Davidovits of *The Pyramids, an Enigma Solved*. Davidovits proposed that the stone work in ancient Egypt was actually poured in situ, not cut. With his theory, he hoped to explain how the cyclopean monolithic blocks—which many believe suggest a higher level of expertise than allowed by conventional theory—could be produced using simple methods available to primitive cultures. I gave only two pages in *The Giza Power Plant* to Dr. Davidovits' theory, but in those pages I addressed the poured stone theory sufficiently for a reasonable person to form an opinion about its validity in relation-

■ BY CHRISTOPHER DUNN

ship to the new information that I had uncovered.

In May 2000, I was challenged by Morris to debate in the *Skeptical Inquirer*. She advised me that we eschew using the Internet as a forum for our debate; she also advised that we avoid magazines such as *Atlantis Rising*, where we would be "at the mercy of the editor." In an e-mail she wrote: "The debate must remain on a polite, professional level so that it cannot be rejected by an editor on the basis of unprofessionalism. Do not take this remark personally—I mention this only because of some of the ugly, unprofessional exchanges that go on, which I trust neither of us wants to be a part of."

To which I responded "Dear Margie, This is acceptable to me. I agree with you about rising above the ugly Internet free-for-all....I am going out of town for a while and will address the subject when I get back."

For a long list of reasons, including my computer crashing and vaporizing all my e-

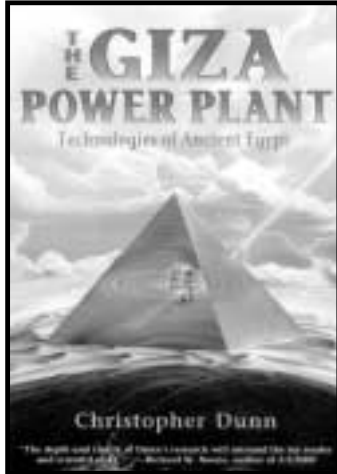

mails and addresses, I was unable to engage Morris immediately in this debate. It was my intent, though, that after I had cleared my calendar, I would take it on. Morris, on the other hand, could not wait to do battle. I received an e-mail from Jeff Rense (the *Jeff Rense Program*), who informed me that Morris and one of her supporters, named Robert, were e-mailing him criticizing him for interviewing me. The approach did not help her cause with Jeff, for though I asked him to have both of us on the air to discuss these issues, he respectfully declined, stating that the attitude and hostility displayed by

Ms. Morris was not conducive to a fruitful debate. Morris's true character was soon to become evident.

When her tactics with Jeff did not work, and against her own advice to avoid unprofessionalism, Morris then turned to the internet to campaign against my work and posted two blistering reviews against my book on Amazon.com.

Because of the angry, ad hominem and ob-

vious self-promoting content of the initial review, I asked Amazon if the review was consistent with their posting policy. I was offered an apology and informed that Morris's review was not and would be removed. After it disappeared, Morris posted again. Again Amazon gave an apology and said that it would be taken down and a note of explanation would be sent to Morris.

Morris evidently is not one to take a hint or listen to advice. The review she posted next was even more vociferous and insulting, and I began to realize that it was futile to correct her public outburst of resentment and acrimony. I also recognized that with a new self-published book to sell, she may feel that attacking an author with whom she disagrees—and whose ideas are becoming popular—could be an effective way of getting attention. It has worked for other authors, why not her? (Note that all of Morris's reviews on Amazon are negative, antagonistic and self-promoting, rather than being objective reviews of the material.)

Finding more about Morris through the link on Amazon, I discovered her website www.margaretmorrisbooks.com and was amazed at how busy she has been waging her campaign against my work and me. My irritation turned

Continued on Page 60

Cell Phone Protection Devices

Cellular phones radiate noisy electro-magnetic fields (EMF) linked with symptoms including Headaches and Fatigue. Studies have repeatedly shown adverse health effects.



www.FutureTechToday.com

Water Revitalization Products

Bring dead water back to life and rejuvenate your body!

The original Vortex Energizer™ restructures your water at the molecular level by increasing its spin for better hydration and efficient nutrient absorption.



Mention coupon code #107 and pay only **\$149**

Latest Japanese Microwater™ Ionizers
Life Field Polarizer™ EMF Protection Products
Latest Electro-Medical Devices

Toll Free: 1-866-747-7447

Protect yourself and those you care about.

FREE CATALOG

Radiac®

The Edgar Cayce Radial Appliance (pronounced ray-dee-ack)



Recommended over 1000 times in his readings. Edgar Cayce said the Radiac could benefit anyone. The Radiac is featured in the books *Supermemory* and *Superlearning 2000*. Impeccably designed to improve meditation, visualization, and spiritual development, refresh and realign your energy, harmonize the flow of life energy, and enhance your dreams.

Edgar Cayce Remedies • Wet Cell Battery
Radial Active Appliance • Violet Ray • Castor Oil
Massage Oils • Vitamins
Complete Edgar Cayce Readings on CD-ROM

Visit Our NEW Web Page at:
www.baar.com

Call for a complete catalog of products
Baar Products: **610-873-4591** M - F 9AM - 6PM
(be sure to mention *Atlantis Rising Magazine*)

Eden in Armenia

Finding the Home of Adam and Eve Can Take Serious Detective Work

If you care to hold a quick poll of your friends, asking them where they think the Garden of Eden was located, about nine out of ten will say they don't know, while the rest will give answers ranging from Sri Lanka to the Jordan River in the Holy Land. None will mention Armenia, yet this is where Noah grounded his Ark, somewhere in the mountains near Ararat, thus starting the human race for the second time according to the Bible.

His distant ancestors were, according to the same source, Adam and Eve, who lived in the distinguished company of some angels in a place called Paradise. In Sumerian territory, otherwise present day Iraq, Paradise was known as Dilmun or a host of cognates with more or less the same spelling. Dilmun was in fact the area known today as Armenia and Azerbaijan located between the Black Sea and the Caspian Sea, and may be defined more specifically as the Lesser Caucasus, overhanging and extending to the shores of the Caspian, and including the mountains of Ararat. Those inclined to niggle may point out that Ararat is just within the border of Turkey, and deny that this now barren upland region could ever have been described as a paradise. The critic could not be more wrong.

Current travelogues describing the valleys of the Lesser Caucasus are unanimous that the area is very suitable for a residence of the gods, remarking on the pure air, the sparkling waters, the abundant game and wild-life, and the unusual longevity of its inhabitants. In particular, we would like to point to the Aras Valley near the capital of Armenia, Yerevan (Erevan).

One of the first things Noah did when he disembarked from his Ark



Adam and Eve. Raphael

was to plant grapes, on the fruit of which he became dead drunk, according to the Bible, and yes, the Aras River valley grows excellent grapes to this day. Any area claiming the status of a paradise must also grow apples for the tempting of any wandering Adams and Eves, which we also find in this locality.

Having placed some principal early Biblical characters in Armenia, presumably including the direct descendants of Adam and Eve, who were herders and metalworkers, we might ask if we ought not to transfer the scenarios of Genesis right out of the Holy Land altogether, and move the stage a few hundred miles north?

In particular, the Yerevan/Aras Valley has been continuously inhabited

by successive races of tool-using hominids for upwards of 400,000 years, and most of the improvements in stone-age hardware originated near here, and were then exported to less advanced regions. By 2500 BC, the Armenians were able to make armor or tool steel, ceramics, glassware, metallic paints and 14 different kinds of bronze. Those who say the pyramid builders could have had nothing better than hardened copper tools should consider the properties of Armenian manganese steel.

Eventually, around 1200 to 1000 BC, the Armenian smelters, consisting of over 200 furnaces at Mecamor, were overrun and thus began a dearth of good bronze in the Middle East that

Editor's Note: Atlantis Rising frequently receives first-person reports and essays from readers which describe original research and discoveries which they have made. Previously (before issue #25) it had been our policy not to publish such material. The reasons had to do with limited space and the intention to maintain our own credibility by sticking with third-party objective reporting of material which is making news. Also, it is important to remember that this is not a professional journal devoted to pure research and we cannot become overly technical. However, much of the material we receive, despite the subjective bias of the writers, is of very high quality and we feel that at least some of it should be passed on to our readers. For that reason, we are now devoting regular space to the original research of our readers—one discovery per issue. Let us know how you like it.

■ BY ANTHONY B. AUSTIN

Continued on Page 28

**USERS CLAIM NEW INVENTION
STOPS AGING PERMANENTLY!!!**

ImmortalityDevices



Hand-made in the U.S.A.



\$105 a Set

+ s/h

100 days refund
guarantee

**Based on countless testimonials,
Alex Chiu's Immortality Devices®
are believed to stop you from
aging permanently!**

MCAT®—Magnetic Cellular Activation Technology—works while you sleep, using pairs of polarized magnets at key points along the meridians of the human body to create vortexes of magnet flux that strengthen and focus the flow of chi, promoting health, healing, and energy.

Stop aging or your money back.

Visit www.liveforevernow.com

"I'm 63 years old (Male), and I've been using the devices for close to 2 months. . . I'm already noticing some changes in my body. . . the frequent stomach aches are a thing of the past. I feel more energetic than before. My white hair is turning back to original black which really surprised both me and my family! Thank you for bringing my youth back!" **M.S.H.**

"I'm a 65-year-old man who's been using the ImmortalityDevices for about 3 months. . . My white hair is getting back to my original color. . . I feel lighter and more energetic. . . They (*ImmortalityDevices*) have really put some spring into my step! Thank you very much!" **M.H.K.**

"I'm a new mom. I gained 40 pounds which really took a toll on my knees. Every step I took was

painful. . . No remedy worked long enough. . . After 2 nights (of using the *ImmortalityDevices*) I began to notice a dramatic reduction in the pain in my knees! I'm telling EVERYBODY about *ImmortalityDevices*. Thank You!" **A.H.**

"Something is working. I got the *ImmortalityDevices* about five days ago. Within two days, I no longer felt as bloated after eating as I once did. I'm 42." (Male) **M.U.**

"Hi! We are using Alex Chiu's Rings since February and are very happy with them!!!! My sleeping disorder needs only half the medication than before now, which saves a good amount of money. My wife uses a lot less pain pills than before and her hot flashes can now be controlled with herb medication and not the expensive prescription. Thanks!!!!!" **H.R.**

**To hear recorded testimonials
24 hours
dial (800) 757-1933**

To order, call TOLL FREE 24 hours: (888) 363-9184 ext. 27
or to order by mail, send check/money order for \$114.95 (includes s/h) to:

ImmortalityDevice.com Inc.

8 Rippling Brook Court • Dept. 27 • Silver Spring, MD 20906

Your Online Supersource Store!



WWW.FROMTHESOURCE.NET

Everything for occult, Wicca, psychic, spiritual, esoteric, erotic, health & healing, links, and more! Supplies, gifts, jewelry, tarot cards, plus! Log on today for treats from the universe.

THE THIRD MILLENNIUM TAPPING THE UNDISCOVERED SELF

Milo Kovar's new book dealing with the intriguing vistas of the next Millennium's effects upon human nature and its evolutionary potential. - \$15.00 + \$2.00 S&H



2640 Greenwich, Apt. 403
San Francisco, CA 94123
Daily 8:00am- 6:00pm
Tel: (415) 921-1192
Cash, Checks, Travelers Checks

Kabalah: A Process of Awakening

This exciting home study course not only establishes and redefines traditional Kabalistic knowledge, but also provides a philosophical/psychological/spiritual and, most of all, transformative process of development. It teaches the wisdom, understanding and use of the Tree of Life, incorporating both the mysticism of Judaism and the esoteric teachings of Christianity.



Karin Kabalah Center offers a Seminary Program for Ministry and Priesthood in the St. Thomas Christian Church, available to students enrolled in our correspondence course.

For information on enrollment as a Kabalistic student or in the Seminary Program, write or telephone.

KARIN KABALAH CENTER

2531 Briarcliff Rd., N.E.
Suite #217
Atlanta, GA 30329
(404) 320-1038



Distributors of Vogel Crystals
<http://www.mindspring.com/~kabalah>

EDEN IN ARMENIA

Continued from Page 26

would not be rectified until the Phoenicians discovered the ores of Cornwall.

As surviving temples tell us, the Armenians were very much interested in astronomy, laying out lines that pointed towards Sirius, and leaving us place names that pointed towards the origins of their earliest gods and mentors, who quite simply were said to come from Mars, or Khvaniratha as this planet was called. These gods were six fingered, possessed considerable stature, and were blonde, blue-eyed people, according to Armenian legend and temple decoration. The legend of Noah and his Ark is nothing but a myth constructed around the true story of a landing from Mars.

Even today, the Armenian language has affinities with Slavic, Baltic, and other blonde races, but belongs to the Indo-European family. The key to their Martian contacts comes through words like 'van' 'rat' and 'kar' which have no meaning in Armenian, Turkish, or Georgian, but survive as place names liberally dotted over the landscape.

Those in doubt may examine Zoroastrian beliefs which date back to the Stone Age, whereupon the researcher will find not only the correct name for Mars, but the names of prominent volcanoes such as Hara (Olympus Mons), the one-time Martian Ocean (the Vou-rukasha Sea) and even the one island in the middle of that sea.

Using Parsee, Zoroastrian, and Sufi literature, one may construct a rough map of Mars, such as that by Corbin (see illustration) where it may be observed that Martian ideas on cartography do not exactly correspond with our own. The equinoxes were of paramount importance to them, thus dividing Mars into six regions.

These regions were called keshvars. Naturally, this kind of cartography was transferred to Earth, becoming the current 'Star of Israel' and what is called 'Rennes geometry' after a site in the southwest of France, said to be connected to myths of Jesus Christ, the Templars, and a great treasure.

The original of these designs is found in Armenia, using the volcanic mountains Ararat and Aragac as prime reference points, and encompassing the Yerevan Valley.

Many villages are thus intersected, but where no village appears on a modern map, it may be because that village was erased by either volcanic eruption or the Armenian Holocaust of the First World War when one-and-a-half million Armenians were slaughtered by the Turks.



Map of Yerevan Valley

We have refrained from completing the diagram with other lines that might produce a 'vesica pisces' or other 'sacred geometry', preferring to keep things relatively simple.

The story relating to this 'star' of six points is given in Jewish legend, where two angels, Raziel and Samael gave a peculiar stone to Adam, telling him that it would inform him as to the names of plants and animals, the heavens, and even what would happen to Adam to the end of his days. This stone is said to have been a sapphire, which exhibits asterism; that is, the stone will show six rays in its interior if carefully polished.

The stone is thus blue and white; the colors of the Israeli flag, but a more exact representation of a star sapphire can be seen in Armenian churches, where it appears as six 'petals' within a circle, connected (oddly enough) to a sleeping dog! The dog is Sirius.

Adam's stone would appear to us in the 21st century as a personal Computer cum word-processor, spell-checker, astronomical and astrological computer, and a handy botanist's guide all rolled into one. Not impossible today, but remember, this was about 8,000 years ago! Adam looked after it very carefully and handed it down through the generations until it came into the possession of Enoch, the same who is supposed to have voyaged to the heavens, and then it was given to King Solomon.

The story of the 'angels' can be read today, while Raziel/Azazel was the one who loved to sit beside the river which is today called the Aras, and Samael is known to be connected to Mars. ■

Works by English author Tony Austin, include "Return to Mars" with Brian Crowley, "The Dragon's Tail" and books on prophecy. He currently lives in West Sussex.



FATHER ERNETT'S CHRONOVISOR:

The Creation and Disappearance of the World's First Time Machine
By PETER KRASSA

**"Certainly a cult classic in the making."
-FORTEAN TIMES**

**"...has garnered huge critical acclaim."
-X FACTOR**

HAS TO BE READ TO BE BELIEVED

224 pages, Illustrated, ISBN # 1-892138-02-6

Available from **NEW PARADIGM BOOKS**

\$16.95 plus \$3.20 s/h. All credit cards accepted.
22783 South State Road 7, Suite 97, Boca Raton, FL 33428,
Tel: (561)482-5971 Fax: (561)852-8522 E-mail: jlc@flinet.com

Visit our website at www.newpara.com
Read our online **JOURNAL OF PHIN-DIMENSIONAL LITERATURE**

Also available through ACCESS, NEW LEAF and in all bookstores.

NEW PARADIGM BOOKS



Read the Books of Paul LaViolette

In **The Talk of the Galaxy**, Paul LaViolette provides first time proof of the existence of interstellar radio signals of intelligent origin, evidence that pulsars are part of a vast network of ETI communications beacons. **Paper \$16.00**

Earth Under Fire relates the discovery of a scientifically advanced time-capsule cryptogram written in the constellations informing us about the Galactic cause of the legendary conflagration and Deluge. Drawing partly from ancient lore and partly from an extensive array of astronomical and geological evidence, LaViolette skillfully fits together the scattered pieces of this cosmic puzzle allowing us to understand for the first time the catastrophe that humanity endured thousands of years ago, one that could recur today virtually without warning. **HB \$29.95 Paper \$20**

Beyond the Big Bang explores the astonishing parallels between cutting edge scientific thought and creation myths from the dawn of civilization. Blending modern systems theory with the ancient notion of an underlying medium, or ether, LaViolette explains in direct, nontechnical language how ancient myths and esoteric lore encode a theory of continuous creation, one in which matter is continually growing from seeds of order that emerge spontaneously from the surrounding subquantum chaos. **HB \$29.95**

Call 1-800-715-9993
www.etheric.com

CREATE PERFECT HEALTH TODAY

VIBRATIONAL ENERGY ELECTROMEDICINE

♥ CURATIVE ♥ PREVENTIVE ♥ CREATIVE HEALTH AT IT'S SPECTACULAR BEST

For all issues of Emotional, Mental, and Physical Well Being: Pain, fatigue, stress, insomnia, depression, anxiety, addictions, detoxification, immune enhancement, devitalization of pathogens (parasites, mold, yeast, fungus, viruses, bacteria), neutralizes negative thought forms, rejuvenation, regeneration, vitality, expanded consciousness, etc.

Advancing the research of The Masters of Free Energy: Tesla, Royal Raymond Rife, Lakhovsky, Abrams, Ed Skilling, Bob Beck, Sky David and others.

NEW BRAIN TUNER BT-5 PRO
Dr. Bob Beck
\$195
Silver & Magnetic Pulsers and Water Oscillator by SOTA

"I slept the night with the UFSB VIII, when I awoke my severe flu symptoms were completely gone" KE, San Diego

"I'm off cigarettes and alcohol after two weeks on the Brain Tuner" SD, San Francisco

Ultra Photon Sound Beam VIII
\$1997
Rife/Lymph/Parasite Noble Gas

3 Noble Gas Applicators, RF Room Broadcaster, Sound Probe, 7 Universal Rife Frequencies, Sweep, Variable Pulse, 16 Upgrades

Essential Photon Sound Beam
Special \$995 thru March

ATP Inductor 2000 Ruby Gem Radiance
LifeForce Energy DNA Activation
Sky David

"The lumps in my breast are gone in just 2 weeks and I can walk again." MD, Vail, AZ

"I had chronic knee pain for 11 years, one 30min session and it disappeared." JT, NY, NY

"My dear cat was dying; he hadn't eaten in 3 days. After one 10min session he jumped down from his perch and began eating. It's a miracle. He was instantly healed." LH, Sedona, AZ

WE HAVE IT ALL

8000 Electromedical Series: Parasite Zapper, Silver/Gold Maker, Pulsers, Blood Purifier • E/M Field Protection for Body, Home & Office • Holographic Radiotics • ChiMachines • Light-Color Regenerative Technology • **RIFE/LYMPH/PARASITE NOBLE GAS TECHNOLOGY** •

2 Year Service Warranty/Personal Health Consultation
Technical Support Included

ELECTROMEDICINE

THE WAVE OF THE FUTURE TODAY
ONE SOLUTION TO ALL PROBLEMS

FREE INFORMATION: 4 Excellent Cassettes and 50 Page Brochure \$10 IHS, PO Box 817 Sedona AZ, 86339, City of Peace, (602)280-9069

www.jcau.com/energymedicine
Serving You With Love since 1987



Further Explorations in the

Hall of Mirrors

**A New Book from Harvard Professor John Mack
Digs Even Deeper into the UFO Abduction Experience**

It has been awhile since we have heard from Dr. John Mack, and many have wondered what he has been doing since his extraordinary book, *Abduction: Human Encounters with Aliens*, first burst upon the scene in 1994. That book was greeted with gushing plaudits from such literary bastions as the *New York Times*. Among the adjectives used in their review were "absorbing, powerful and touching." They said further, "the abduction experience...is...as Dr. Mack understands, an aspect of something bigger...and a sign of an urgently needed individual and collective transformation."

Coming, as it did, from a respected Harvard Medical School psychiatrist, the book arrived with the patina of establishment respectability, and was, in retrospect, the breakthrough event that transformed incidents perceived by the media and the masses as wild and somewhat wacky, to phenomena deserving serious sociological and scientific scrutiny. Whitley Strieber's *Communion* had almost achieved that breakthrough. That book was near the top of the *New York Times* non-fiction bestseller list for six months in 1987. But then two years later came the

movie which somehow managed to throw the whole package into the pile labeled, "Imaginative Horror Stories." And no matter how many times Strieber assured us that it was a true story, that's where it stayed, testifying once again to the awesome power of film to "make or break." The Hollywood treatment of abduction incidents makes them subject to popular ridicule, and usually destroys whatever fragile, tenuous grip that they previously had on credulity.

Fortunately, the two books written by Budd Hopkins, *Missing Time* and *Intruders*, were never made into movies, although material from *Intruders* was used in a TV documentary in 1992. Hopkins was clearly the pioneer in bringing the abduction scenario before the public. But, as an artist, Hopkins just doesn't have the credentials for this work, and so he has been a very large target for all of the doubters and skeptics who seem to have made UFO debunking their profession. And so slowly, his credibility has been chipped away, despite his careful and thorough reporting. But because of Dr. Mack's impeccable credentials and prestigious affiliations, *Abduction* has stayed in the spotlight. Consequently, until now, it has been perhaps the only credible foundation upon which to base ulti-

mate public acceptance. But now, Dr. Mack has added a new dimension to his original work.

His new book, *Passport to the Cosmos* (Three Rivers Press, 1999, New York), takes us down the very hazardous, mine-strewn path of trying to make some sense of the abduction phenomenon. While *Abduction* is primarily a record of his psychiatric/hypnotic sessions with selected abductees, with some added commentary, *Passport* tries to put it all together. It builds on the work done in the previous book, but takes on fully the challenge of interpretation. This is a challenge that several other great minds have taken up, and the opinions are very diverse. Unlike a jury trial where a verdict can usually be rendered from the available evidence, in this case the same evidence can lead to any of dozens of equally plausible conclusions. Or, as Linda Moulton Howe has so succinctly summed it up, it is like being in "a hall of mirrors with a quicksand floor."

A New Research Paradigm

Because of the importance of this long-awaited follow-on to *Abduction*, we interviewed Dr. Mack recently for the magazine. We hoped to get a sense of his motivation in writing the book,

■ BY LEN KASTEN

and to get an update on his status with his academic colleagues. It may be recalled that *Abduction* was greeted by a storm of criticism within the scientific community, ultimately compromising Mack's status at the Harvard Medical School as an academic psychiatrist.

A review by James Gleick in the *New Republic* magazine referred to the abduction phenomenon as a "mythology" and called it an example of the "anti-rational, anti-scientific cults that are flourishing...in the United States." Psychoanalyst Sanford Gifford called it a "subversive assault on psychoanalysis as a science" and said that abductees are " 'crazy' in the same way as believers in Creationism, faith-healing," and "thought transference..."

Mack sums up all of these criticisms as coming under the umbrella of what he calls the "materialist paradigm." It was his position in writing *Abduction* that this paradigm apparently no longer works, since it cannot be stretched to accommodate these phenomena. He says in his Preface to the paperback edition, which he wrote in 1995, "The fact that what the experiencers are describing simply cannot be possible according to our traditional scientific view would, it seems to me,...call for a change in that perspective, an expansion of our notions of reality, rather than the 'jamming of data

into existing categories' that some critics would have us do."

The plight of the enlightened researcher is probably best represented by a quote in *Passport* by eminent MIT physics professor Victor Weiskoff, who reportedly said to theologian Houston Smith, "We know there's more. We just don't know how to get at it." It was this dilemma that prompted Dr. Mack to found a new research organization called PEER (the Program for Extraordinary Experience Research) in 1993, that would accommodate these types of experiences, and that would be based on the premise that when dealing with phenomena that do not fit our definition of "reality," we need a new way to study them. Ultimately, Mack concludes that his psychiatric training was the most useful preparation possible for interviewing abductees because he was taught to use "not just our intellects, but our hearts and souls, our whole selves." This method he refers to as *consciousness as an instrument of knowing*.

The Limitations of Three Dimensions

In both books, Dr. Mack says that no matter how incredible these abduction stories may seem, they are undeniably real experiences, and the abductees are perfectly sane. In answer to

those who suggest that these may be dreams, he says, "...the person realizes he or she was not asleep...; they feel they have remembered something that actually occurred; the narrative has a logical sequence, however strange its content; and the episode, when recalled, or relived, may be accompanied by intense emotions and bodily reactions more usually associated with remembered events than with dreams."

Coming from a psychiatrist, this is convincing enough. But scientific believability gets stretched when the abductees talk of "other dimensions." They frequently report "being taken into another dimension or plane of reality with different properties." In this other dimension, they usually experience time, space and dimensionality in a different way. One abductee, Karin, interviewed by Dr. Mack refers to this as "the fourth dimension." Another says, "It was not a place like we have here, not in our space/time."

In this state, the experiencers frequently notice a change in perception, which several have attributed to an altered state of consciousness. They may see or hear things that others cannot see or hear. Apparently, the aliens somehow have the capability of increasing the vibratory rate of the mo-

Continued on Page 63

If You Believe:

- **PAYING TAXES IS YOUR DUTY • THE GOVERNMENT WILL TAKE CARE YOU • YOUR WILL IS JUDGEMENT PROOF**
- **PROBATE WILL NOT EFFECT YOUR ESTATE**
- **THE IRS WILL TELL YOU HOW TO REDUCE YOUR TAXES**

Then Do NOT Buy This Book!

The Kenzington Report

FIND OUT ABOUT

- **ASSET PROTECTION • TRUST STRUCTURE**
- **TAX LAWS IN YOUR FAVOR • LIVING AND IRREVOCABLE TRUSTS • AVOIDING NUISANCE LAWSUITS • THE SPIRITUAL SIDE OF TRUSTS • THE ADVANTAGES OF SHARED RESOURCES**
- **AND MUCH, MUCH MORE!**

Send \$40.00 + \$5.00 S & H to:

The Kenzington Fund
3250 Olympic Blvd., # 10
Santa Monica, CA 90404
(310) 398-1705 - (800) 923-8846 - Fax (310) 398-6370
Visa - MC & Fax Check accepted

The Kenzington Fund is a full service trust consulting company, specializing in Trust Administration Training

Call for your Free ♦ Free 5 minutes of trusts consultation

- ♦ **Free newsletter "The Journey of Trust"**
- ♦ **Free brochures "Own Nothing, Control Everything" and "The Search for Trust"**
- ♦ **Free links to trust info: Kenzington@juno.com**

Treat yourself to the knowledge that sets your children Free

Future Horizons Advanced Technology
Po Box 125 Marquette, MI 49855 www.futurehorizons.net

Philosophers Stone
 Called White Powder Gold, Mana or Elixir of life. A room temp super conductor gelatinous mixture. When ingested, every cell in the body is returned to a state of purity as a child. It perfects the DNA and harmonizes the light body. Effects are: Telepathy, knowing good and evil instantly, levitation...
WPG6 Plans/Info-\$46.00

Rife Machine
Invented in the 1930's but suppressed by the AMA (American Medical Association), has reportedly cured: cancer, aids, diabetes, and more.
RIF2 Plans/Info-\$20.00
RIFZ Ready to Use-\$700.00

Electronic Mind Control
 Control minds with this simple technology. Others will do anything you program them to. Get that raise you always wanted or reprogram your own mind.
MIND Plans/Info-\$20.00
MINZ Ready to use-\$150.00

Wishing Machine
 The equivalent of an electronic genie, it amplifies brain waves to make your wishes literally come true! Experimental device proven effective in lab tests
WISH Plans/Info-\$25.00
WISZ Ready to use-\$150.00

Hyperdimensional Resonator
 Hooks to the users head and by setting the dial, it causes an out-of-body experience or Astral projection to occur. Once out of your body, you can travel in time and space.
HYPD Ready to use-\$360.00

Time Travel Anthology
Plans and diagrams for many different types of time machines and devices for astral or physical time travel. (includes (3) hours of taped interviews about time travel with inventor Steven Gibbs)
Contains over 300 pages of data!
TTAN Anthology + tapes-\$188.00

Please add \$5.00 Shipping/Handling, Overseas \$11.00
(906)249-5197 24 hr order only line (906)249-1525 Fax
Pay by Visa, MC, Amex, Disc, Chk, Mo, Cash Send \$3 for catalog

If an astronaut were ever to corroborate an aspect of my writings, I would have expected it to be in regard to planetary matters. Surprisingly, such a corroboration concerns, of all things, the Olmecs of ancient Mexico.

The unexpected corroboration is tucked away in the recently published book *A Leap of Faith* by the Mercury-7 astronaut Gordon Cooper, in

which his story as a test pilot and astronaut is peppered with (to quote from the dust jacket) "his strong views on the existence of extra-terrestrial intelligence—and even the distinct possibility that we have already had contact."



Astronaut Gordon Cooper

The Olmec Enigma

Readers of my books, and especially of *The Lost Realms*, as well as of a previous article on my website titled "The Case of the Missing Elephant," know by now that beginning with the discovery of a colossal stone head in 1869, an advanced civilization that preceded the Mayas and Aztecs of Mexico came to light. Its leaders and bearers were unmistakably black Africans. They were arbitrarily named by archaeologists "Olmecs"; and their embarrassing enigma—of who they were, and how they had come across the ocean, and why, was compounded by the timing of their arrival in the New World.

Once it was conceded (very grudgingly!) that the 'Olmecs' did indeed represent the earliest or even Mother Civilization of Mesoamerica, the date of their arrival was at first set at about 250 B.C.; then at about 500 B.C.; then farther back and back, until 1500 B.C. was acknowledged.

But I have argued for a date twice as old!

A God and His Secret Number

My conclusion that the Olmec presence in the New World went back at least 5,000 years, to circa 3000 B.C., was reached by many paths. The first one was an attempt to identify the great god of Mesoamerica, the Winged Serpent (Quetzalcoatl to the Aztecs, Kukulcan to the Mayas), and the significance of his promise to return to those lands on the first day of a 52-year cycle, (A.D. 1519, when the Aztec king Montezuma believed that the appearance of the Spanish conquistador Cortez was such a Return, coincided with the anticipated sacred date).

The peoples of Mesoamerica employed in addition to a practical calendar of 365 days, called the Haab, also a Sacred Calendar (called Tzolkin) of 260 days. The two cyclical calendars were conceived as two wheels with meshing teeth that turned and returned to the same spot once in 52 years; and 52 was the Sacred Number of the Winged Serpent god!

Since 52 was also the Secret Number of the god known to the Egyptians as Thoth, since Thoth as Quetzalcoatl, was the god of science and the calendar, and since Thoth was exiled

How Old Were the Olmecs?

Very Old Indeed, Says Best-Selling Author Zecharia Sitchin and He's Not Alone

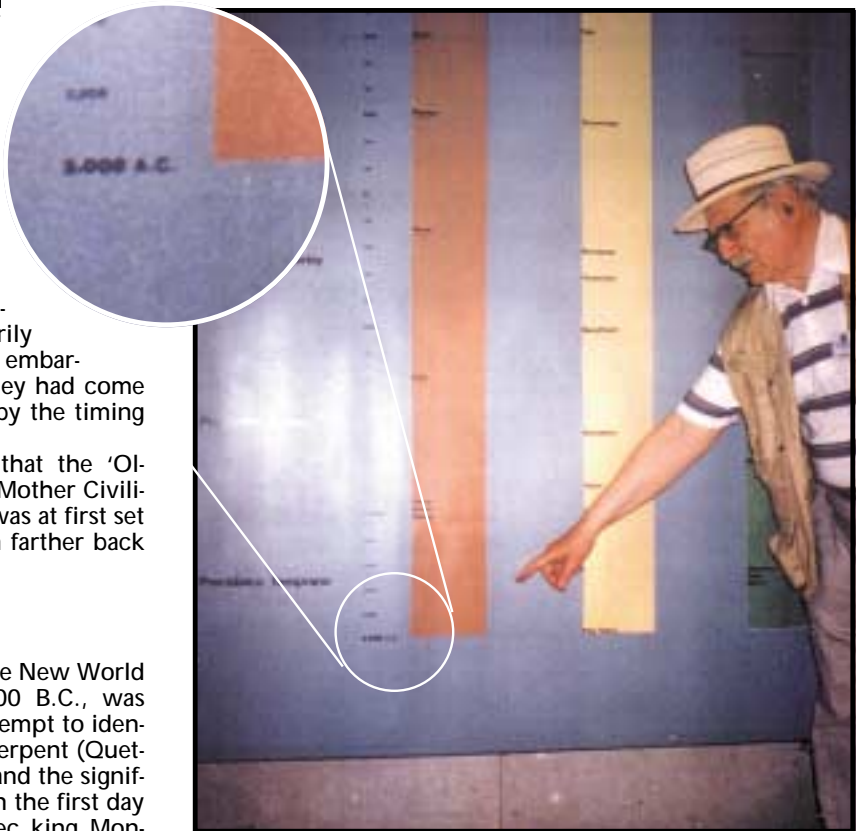

The author with telltale chart

from Egypt circa 3100 B.C., I have suggested that it was he who took a group of his African followers to a new land, bringing the "Olmecs" to Mesoamerica.

Accordingly, I said, Olmec presence goes

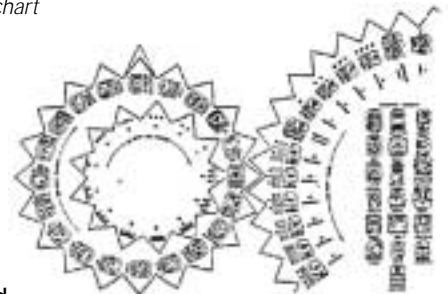

Continued on Page 64

BY ZECHARIA SITCHIN

Excess Heat: Why Cold Fusion Research Prevailed

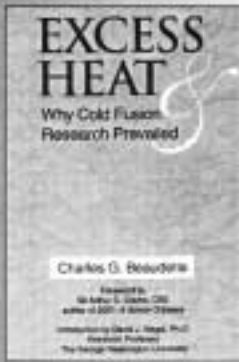

"Charles Beaudette has done a remarkable job in untangling and documenting the whole story of cold fusion. Excess Heat is not only a superb record of an extraordinary episode, but is also highly entertaining."

—Sir Arthur C. Clarke

May 2000, 306 pp.
Paperback \$29.95
Postage included

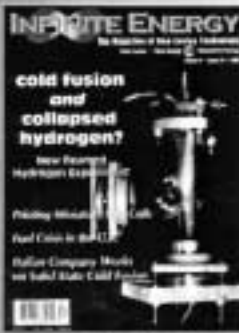

Infinite Energy Magazine

SAMPLE • \$5.95

Cold Fusion Technology, Inc.
P.O. Box 2816-AR
Concord, NH 03302-2816
Phone: 603-228-4516
Fax: 603-224-5975
<http://www.infinite-energy.com>

MOTION WITHOUT FORCE!

Have you ever wondered why the scientific establishment suffers severe apoplexy at the mention of perpetual motion machines?

With the edifice of Modern Science resting on the greatest perpetual motion machine ever devised by the mind of man, a solar system where planets are thought to rotate and orbit without the application of current force, highlighting an obvious impossibility is not appreciated.

It all started with Kepler!

WHERE SCIENCE WENT WRONG TRACKING FIVE CENTURIES OF MISCONCEPTIONS

Peter Bros

The 7th Volume of The Copernican Series

\$15 Postage Paid from the Publisher
Send check or Money Order to
FBP, 6529 Elder Ave, Springfield VA 22150
or order on-line from Amazon.com

NEW Science Fiction Novel that reads like TRUTH

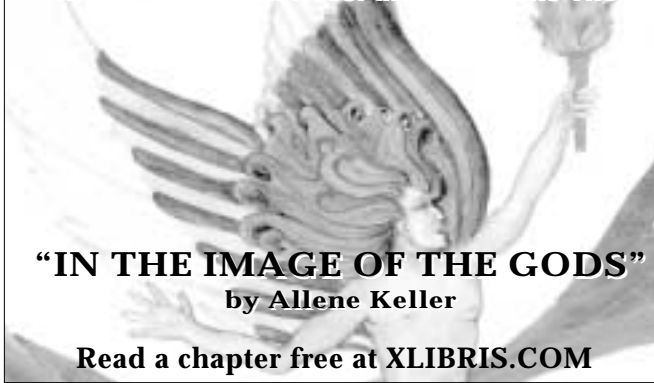

"IN THE IMAGE OF THE GODS" by Allene Keller

Read a chapter free at XLIBRIS.COM

FLOWER OF LIFE WORKSHOP

Madison, WI every other month
Chelan, WA Feb. 16 - 18
Kona, HI Feb. 19 - 25*

*Includes Dolphin Swim

Raleigh/Durham, NC Mar. 2 - 4
Tucson, AZ Mar. 9 - 11
Bristol, VA & TN Mar. 23 - 25
Mrdhd City, N.C. Mar. 30 - Apr. 1
NYC Apr. 6 - 8
Ithaca, NY May 4 - 6
or host a workshop in your area

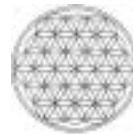

The Ascension process is accelerated through the remembrance of the Mer*Ka*Ba, a crystalline energy field in a specific geometry structure extending around the body for 55 ft.

Flower of Life Workshop
as taught by Drunvalo Melchizedek

Maureen J. St. Germain, Facilitator
maureen.st.germain@home.com

608-837-9648
888-326-4660 ext. 9406



www.theUFOstore.com
The largest selection on the internet!

UFO Videos & Documentaries
UFO Books
UFO Collectibles
UFO Accessories & Giftware

NEW RELATED Videos Section
on Ancient Civilizations, Crop Circles, Conspiracies, Hearings, Forbidden Science

CD-ROMs
Books
T-Shirts
Videos
Alien Figures



Father Pellegrino Mario Ernetti



Christ on the cross allegedly taken by Ernetti's Chronovisor

The Priest and the Time Machine

Fraud? Or Was Entrenched Authority Out to Hide the Truth?

On September 24, 1953, Douglas K. DeVorss, founder of the DeVorss Publishing Co., was shot to death at point-blank range while working in his office in downtown Los Angeles.

The murderer, who fled and was soon apprehended, claimed DeVorss had been having an affair with his wife. The wife vehemently denied this. Because of this apparent crime of passion, the husband was convicted of second-degree murder and sent to serve out a mandatory five-year-to-life sentence at Chino State Prison.

Was there more to the case than this?

Douglas K. DeVorss was the only person in the world who knew the full story about Baird T. Spalding, author of the four volumes of *Life and Teaching of the Masters of the Far East* which DeVorss had published over the preceding two decades. Spalding, a self-proclaimed millionaire and world-



DeVorss (l.) and Spalding (rt.) in 1935 immediately before embarking from San Francisco to India.

traveler, had died just six months before DeVorss. He had claimed to be 95 at the time of his death, and to have journeyed with a party of twelve in 1894-1897 through India, Tibet, China and Persia (now Iran). Spalding claimed that the material for his *Life and Teaching*—two more volumes of which were published posthumously—came from the teachings of the numerous Himalayan 'elder brothers,' said to assist in and guide the destiny of mankind, whom he had met during the expedition.

Spalding also claimed to have invented, at the end of the nineteenth century, with famed engineer-inventor Charles Steinmetz, a Camera of Past Events, which could peer back into time and even photograph Christ giving the Sermon on the Mount.

Shortly after Spalding's death, it was reported that he had died penniless, and that he had done none of the things he claimed he had done. But, if this were so, how did Spalding come upon the numerous remarkable insights which have fascinated generations of 'New Age' readers of *Life and Teaching of the Masters of the Far East*?

The only person who knew the answer to this question was Douglas K. DeVorss.

On April 8, 1994, Father Pellegrino Mario Ernetti died, according to at least one account in his tiny cell at the Benedictine Abbey of San Giorgio Maggiore in Venice, Italy., some six months be-

Continued on Page 36

ANNOUNCING THE SINGLE GREATEST
BREAKTHROUGH IN THE FIELD OF
HEALTH AND NUTRITION
NOW AVAILABLE TO ALL 'RESEARCHERS':

Ed Skilling's
PHOTON ENERGY SOUND BEAM

Oxygen is VITAL to all living things on planet earth. If the human brain is deprived of OXYGEN for just a few minutes, it will simply begin to 'shut down' and eventually death will occur. Similarly, if human (or even animal) blood becomes chronically low in oxygen a condition called acidosis results. Acidosis in turn is linked to over 150 different disease conditions, and this lack of oxygen retards wound healing and injury repair. Acidosis is also the primary factor in AGING.



The PHOTON ENERGY SOUND BEAM utilizes a patented electrical stimulation process which causes the H₂O in the blood, lymph, and tissues to produce additional oxygen molecules. (O₃ Ozone). As a result, sports injuries and over 150 different disease condition MAY improve and and heal or repair much quicker.

"YOU CAN TRACE EVERY DISEASE AND DEGENERATIVE CONDITION
ULTIMATELY TO A LACK OF SPECIFIC TRACE MINERALS"

Dr. Linus Pauling, 2 time Nobel Prize winner

Finally, a mineral supplement that is in the purest form possible—ANGSTROM-sized particles delivered sublingually (under the tongue) directly into the bloodstream. No more digestive track questions—no more assimilation problems. Just pure molecules of the essential trace minerals the BODY must have to be healthy. Calcium, Magnesium, Silver, Gold, Potassium are just 5 of 20 separate, distinct, minerals with individual vibration frequencies of light ready to give your body what it is starving for.

Add these unique minerals to regular usage of the PHOTON ENERGY SOUND BEAM and the body electric will realize its highest potential.

For more information, contact
ENERGY IMAGES OF SOUTHERN UTAH toll free.
1-800-955-7512



TESTIMONIALS

We were introduced to the Photon Sound Beam about four years ago, and were so impressed, that we purchased one and have been avid users since.

Dr. George Friebott of Priest River, Idaho demonstrated the machines effect on blood cells. I asked if he would check my blood. He agreed, took a sample and showed it on his video screen. There was a lot of "clumping" of the cells, and although I didn't understand what that meant, the DR's twelve year old daughter said quietly, "that's not good." Then the Dr. pointed out the characteristics. He put the Photon Sound Beam probe on the sample and the cells began to separate. Someone in the audience said, "why don't you put Phyllis on the machine." He did, then took a second sample of blood. This sample responded just as it did when he just put the probe on the sample he previously showed on the slide.

As I mentioned, we purchased a machine and have used it for various ailments, including swelling, easing and even eliminating colds, ect.

We take it with us on vacations and use it to help eliminate problems we may have picked up along the way (especially in airplanes with hours of recirculating air).

Now it's a "don't leave home without it item." We're happy and healthy with our Photo Sound Beam.

*Phyllis and Mike Stene
Clark Fork, Idaho*

FREDRICK W. PIRK, D. D. S., M.S., INC.

I find the photon sound beam indispensable in the management of periodontal surgical procedures involving the long term use of membranes. Ridge augmentation therapy can present numerous problems with regard to inflection and long term use of antimicrobials.

Patients who pulsed the surgical sites on a weekly basis for 30-40 minutes appear to exhibit minimal side effects, reduce their dependence on medications, and have a superior osseous healing response.

*Fredrick W. Pirk, D.D.S., M.S.
FACD
FICD*

Director Dental Research, WNHO



Gold & Silver
THE NEW STANDARD FOR TOTALLY
ELECTRONIC LOCATING AND RECOVERY!

Locate: **VEINS • LODES • PROCESSED METALS**

CONSULTATION
INFORMATION
ON-SITE HELP

Call 1-801-782-4800

We guarantee our equipment to out-perform any locating system on the market... or Your Money Back!

Scientists of New Atlantis
 "Atlantis Reborn"
 • Supressed Technology • Time Travel • Invisibility • Radionic Machines • Anti-Gravity • Wish Machines • Orgone • Vogel Type Crystals • Crystal Skulls • Keely • Free Energy • Russian Technology • Levitation • Psychic Energy Waters & Elixirs • Pendulums • Psionic Generators & Helmets • Light & Sound Machines • Alternative Healing • Teleportation • Earth Change Maps • Psychotronic & Alien Technology • Thousands of Products.....
 www.AtlanteanScience.com
 GIANT CATALOG \$4.00
 P.O. Box 2088-A, Palm Springs, CA 92263
 Phone/Fax 760-325-5582

TIME MACHINES
 For Catalog,
 Send \$1.00 US
 Steven Gibbs
 R.R. 1, Box 79
 Clearwater, NE 68726
<http://home.inreach.com/dov/tt.htm>

**Clairvoyant
 Spiritual
 Counseling**
 by Sue Ellen at Coral Ridge
 Call (615) 843-5580 or
 TOLL FREE (877) 431-1447
 Love, Relationships,
 and Life Path Decisions
 \$2.25 per min MV/VI

MUSICAL POTTY makes training
FAST, EASY, FUN!
 Hop On!™ Musical Potty instantly rewards your toddler's success by playing cheerful tunes. Chim-Chim-Cheree, Yankee Doodle and fourteen other favorite melodies make toilet training fun — and what's fun comes easy!
 REDUCE DIAPER USE TO ZERO
 1.800.DIAPER.0 (1.800.342.7370)

 musicalpotty.com
 • ergonomic
 • lightweight
 • easy to clean
 • durable, waterproof
 • batteries included
 • made in USA
 \$22.95 plus s/h
 New Signal, Inc. 117 Oakdale Drive P.O. Box 1566
 Palmer Lake CO 80133-1566 info@newsignal.com

TIME MACHINE

fore his seventieth birthday.
 There is no doubt that Father Ernetti, who, as well as a priest, was a world-class scholar of pre-tenth century A.D. music and a physicist, died of a form of cancer. But, during the last ten years of his life, this brilliant and highly respected monk was strangely silent on a subject which had occupied his conversation at least as much as had archaic music and electro-acoustics: the time machine he claimed to have built, called the Chronovisor.

Father Ernetti said that—with the help of a team of eminent scientists including Enrico Fermi—he had in the 1950s melded quantum physics with ancient astral lore to create his time-traveling device. He said it had enabled him to see back in time and watch Christ dying on the cross. The Chronovisor had also permitted him to peer back to ancient Rome in 169 B.C. and watch the performance of a drama, now lost, *Thyestes*, by "father of Latin poetry," Quintus Ennius.

Father Ernetti exhibited a photograph of Christ on the cross which he claimed to have taken from the chronovisor, and a partial text of *Thyestes* which he claimed to have reconstructed from the performance he witnessed. But he never showed anyone the chronovisor, nor provided more than teasing hints at its construction (it's now said to be dismantled and hidden on San Giorgio Maggiore island). Many have disputed the authenticity of the photo of Christ and the *Thyestes* text.

Yet Pellegrino Maria Ernetti was a world-class musicologist and a proficient scientist as well as a Benedictine

priest, whose views on religious, scientific and other matters were sought out from all over Europe by those as eminent as French President François Mitterrand. Why should a man of such accomplishment and recognition feel compelled to confabulate a story about a time machine?

Why did Father Ernetti, in the last ten years of his life, become increasingly silent about the chronovisor? Was the Vatican gradually suppressing this brilliant man? Were yet more powerful forces suppressing his astonishing invention?

Until recently, traveling through time—in particular, backward in time—had been considered impossible. Today, eminent scientists are beginning to debate the conditions under which it could occur. University of Oxford physicist, David Deutsch, says relativity theory suggests that space-time can become so distorted that bits of it can break off to form closed space-time loops. Such 'world-lines' would be 'timelike' all the way around," says Deutsch; if we followed part of such a closed timeline curve (or CTC) "we could return to the past and participate in events there."

Writing in *Scientific American* for March, 1994, Deutsch and Oxford philosopher Michael Lockwood cite physicist Stephen Hawking as stating that "quantum-mechanical effects would either prevent CTCs from forming or would destroy any would-be time traveler approaching one," making time travel to the past impossible. On a more commonsensical level, Hawking has argued that, if time travel were possible we would be flooded with waves of tourists from the future—and we're not.

Continued on Page 65



Benedictine Abbey on the island of San Giorgio Maggiore in Venice. St. Mark's Plaza in foreground.

YOUR AD COULD BE IN THIS SPACE

ADVERTISING IN *ATLANTIS RISING* IS
EFFECTIVE & INEXPENSIVE

We reach a unique audience,
unserved by any other publication.
Give your business the boost it needs.

Call today for a Rate Card.

1-406-222-0875

The Mysterious Origins of Man Series

New Release!

By the creator of the Emmy-Award Winning *Mystery of the Sphinx*

JURASSIC ART:
two bizarre collections of art depict ancient flying machines, advanced surgical techniques and men attacking dinosaurs. The ICA STONES of Peru, and the ACAMBARO FIGURINES of Mexico: the greatest archeological finds of our times, or the greatest hoaxes?

The Mysterious Origins of Man
The NBC Television Special that sparked an academic controversy.
Did man really evolve from the apes? Human artifacts have been found in rock strata millions of years older than the theory of evolution allows.
Could Plato's "Atlantis" be buried under two miles of ice? Author Graham Hancock (*Fingerprints of the Gods*) reveals how an ancient map may hold the answer.

The Mysterious Origins of Man Series	
Jurassic Art (48 min.) only \$19.95 - msr	
The Mysterious Origins of Man (48 min.) only \$19.95 - msr	
Companion Tape (56 min.) only \$19.95 - msr	
Special Offer: Buy all three save \$10.00	

Ask about our list of other videos and books.
To order call toll-free: **1-800-846-9682**
or write to: BC Video Inc. PO Box 97, Shelburne, VT 05482
Visit our web site: <http://www.bcvideo.com/bcvideo>



Catherine Bennett
Clinical Hypnotherapist,
Reiki Master of the Usui &
Seichim traditions, and
popular seminar speaker on
DNA, healing and spiritual
evolution

ONLY \$33.00 PER SET
(plus \$2.00 shipping & handling)

"DNA Techniques for Activation
is an evolutionary step forward
to betterment."

— Richard Fuller, Senior Editor
Metaphysical Reviews

"...I found the experience of just
listening to her to be healing in
itself."

— Robert J. Resetar
Atlantis Rising

"Highly recommended."

— Tools for Exploration

Mail check or Money Order to:
Voice Contact
31217 Pacific Highway South #209
Federal Way, Washington 98003

TOLL FREE ORDER LINE
1-877-DNA-PLAY (1-877-362-7529)
Visit our website at www.dnaplay.com



Order Your Tapes Today



MYSTERIES

of our Forgotten Past



Who Is Solving the Puzzles?

The Search for Lost Origins contains *Atlantis Rising's* great interviews with the likes of **John Anthony West, Robert Bauval, Graham Hancock, Zecharia Sitchin** and many more, plus incisive articles by **Joseph Jochmans, David Hatcher Childress, David Lewis** and others. Also included: scores of photos and illustrations as well as **16 PAGES IN FULL COLOR.**

THE BOOK TO STRAIGHTEN OUT YOUR SKEPTICAL FRIENDS.

224 pages. Trade Paper

\$14⁹⁵ plus \$3⁹⁵ S&H

(add \$2 ea. for additional copies to a maximum of \$8)

Send check or money order to:

Atlantis Rising Books • P.O. Box 441 • Livingston, MT 59047

or use your Visa or Mastercard and call

800- 228- 8381

**Don't Forget
Your Friends!**

**Order a
10-PACK**

for just

\$100

The Metals of the Gods

The Ancients Were Not Strangers to Sophisticated Sciences of Metallurgy

In order to have high technology, a civilization must have strong metals with which to create machines—metals such as iron and steel. Generally, mainstream science says that man's use of smelted iron is a story of slow and sporadic technological development starting about 5,000 years ago. There is evidence that metallurgy and the manufacture of metal objects, goes back to 50,000 B.C. and before.

The origin of iron, and metallurgy in general, is shrouded in mystery, legend and the mists of time. The Biblical legend of Tubal Cain is about one of the keepers of the secrets of metallurgy. The legend of Osiris tells of how, after his resurrection, he travelled around the world spreading the knowledge of metallurgy and science.

The original discovery of the technique for smelting iron and ultimately making steel is said to have occurred among the Hittites of central Turkey circa 2700 B.C. Knowledge of iron and steel is said not to have come into wide use in the west until about 1200 B.C.

Except for anomalous artifacts, the current archaeological record begins finding iron objects from the third millennium B.C. down to the present period. These accepted specimens, all inferred to be bloomery iron, were found in various places. At Tell Chagar Bazar, in Northern Syria, a fragment of iron was dated to about 2700 B.C.; excavations at Tell Asmar, Iraq, yielded an iron knife blade in a bronze hilt dating to the end of the Early Dynastic period of Sumer (ca. 2450-2340 B.C.); a dagger with an iron blade and a gold-sheathed handle comes from the Royal Tombs at Alaca Huyuk, Anatolia, and dates from circa 2600-2300 B.C.

However, iron objects have been found that are older than 2700 B.C., even according to established archaeologists. Their explanation for these older objects is that they may be "me-

teoric iron" rather than actually smelted objects.

Mining had no doubt been going on for many tens of thousands of years. The metals copper, gold, and silver have been mined since at least 50,000 B.C. The reason for this is that these metals can be extracted and used straight out of the ground. In other words, pure copper can be taken from the ground and hammered directly into a spearhead, knife or sword. Gold and silver are softer, but usable for a variety of items.

Alloys of metal are a different story, but certain alloys are relatively simple to achieve, such as electrum, a mixture of gold and silver. Other alloys, such as tin and bronze, require a certain refining process, and it is here that high technology becomes involved. Platinum has a high melting point, and is also a difficult process.

The discovery of meteoric iron may have spurred the curiosity of the ancients, but is all early iron really from a meteorite, or is it from a genuine smelter?

The Origin of Smelting

It is theorized that the origin of smelting came from the simple heating of gold-bearing sand in order to extract the easily melted metal. The extraction of mercury from cinnabar is similar, though this would seem to have occurred much later. The main reason for this is that mercury is not particularly useful as a metal, or a liquid, except in electrified switches and gyros, as we will see later.

This author believes that mining began at least 40,000 years ago on this planet, and smelting began shortly after that, if not at the same time. While mainstream science believes that iron smelting began with the Hittites, there is still a great deal of mystery in the process.

A major impetus of the Iron Age proper was the discovery of cementation, the technique by which steel can

Continued on Page 41



The Ashoka Pillar in Delhi, India

■ BY DAVID HATCHER CHILDRESS



J. Douglas Kenyon



John Anthony West



Machu Picchu



Robert Bauval



Stonehenge



Zecharia Sitchin

HOW MUCH DID THE ANCIENTS KNOW?

According to the view of mainstream historians, primitive civilization in Mesopotamia, Egypt, and in India emerged from the stone age just over five thousand years ago.

Just a few centuries after what the experts say was the first great labor saving invention of the ancient world, the wheel, society crossed a major divide and headed inexorably toward the modern world. The wheel, we are told, revolutionized primitive society and set the stage for the great achievements which were to follow.

Such is the conventional scenario for the dawn of civilization on Earth. The assumption is, that the rise of highly organized society was unprecedented. If there had been an earlier advanced civilization, we would have discovered unmistakable evidence—highways, and bridges and electrical wiring; plastic bottles, city dumps, and CD Roms. Those, after all, are the things which we will leave to puzzle future archeologists.

But could an ancient civilization have risen to heights similar to our own and, perhaps, have traveled a different road? Would we understand a world which might have employed fundamentally different—though no less effective—techniques to harness the forces of nature? Would we understand, for example, the transmission of energy by means other than a power grid, rapid transit without internal combustion engines, or highly complex calculations involving earth science and astronomy without electronic computers? Have we been surrounded by evidence of such ancient advancements, but not yet, advanced enough ourselves to grasp the astounding implications.

Now a breakthrough video from the creators of *Atlantis Rising* magazine takes a look at real evidence—largely ignored by the academic establishment—which shatters the orthodox scenario for the dawn of civilization on Earth. Now assembled in a devastating one-hour documentary, hosted by *Atlantis Rising* Editor and Publisher J. Douglas Kenyon, are the comments and evidence of breakthrough researchers such as **John Anthony West, Robert Bauval, Richard Noone, Colin Wilson, John Michell, Patrick Flanagan, Christopher Dunn, Zecharia Sitchin, David Hatcher Childress, Edgar Evans Cayce** and others.

Technologies of the Gods —one hour VHS **\$19⁹⁵** + \$4.95 S&H

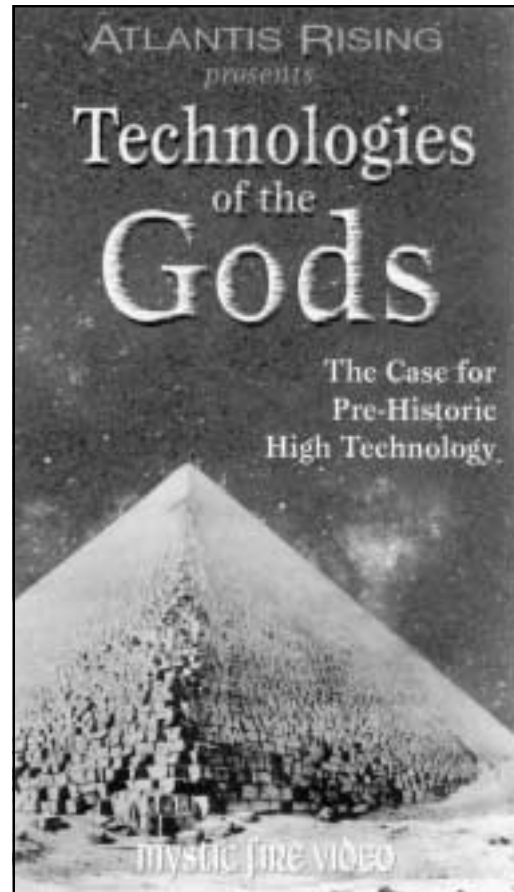

Visa or MC 800-228-8381

Atlantis Rising • P.O. Box 441 • Livingston, MT 59047

AtlantisRising.com

METALS

Continued from Page 39

be produced from bloomery or wrought iron and which is generally associated with the bloomery process. The discovery of this technique is usually attributed to the Chalybes, subjects of the Hittites, and dates to about 1500–1400 B.C. The Hittites are thought to have maintained a strict monopoly on the manufacture of the new alloy, enabling them to keep prices at an artificially high level. This viewpoint is based on interpretations of a letter from the Hittite king, Hattusilis III (1281–1260 B.C.), to an unknown correspondent and is the subject of some dispute.

Iron was the most expensive metal in ancient times—when it could be obtained at all! Nikolass Van der Merwe mentions that “the price of iron during the early stages of the Hittite confederacy (early second millennium B.C.) is known to have been five times that of gold and forty times that of silver, and it must have been even more expensive during the third millennium B.C.. At such prices, iron objects are likely to have been traded as marks of status among the royalty of ancient Near Eastern kingdoms, thus achieving a distribution which is much wider than the actual areas of manufacture.”

Ultimately, the Hittites were destroyed, their capital city of Hattusas vitrified by intense heat, and the modern Iron Age began, according to historians. The secrets of smelting iron were disseminated around the Mediterranean. One question remains: did other nations, such as India and China, already possess the secret of iron?

Metallurgy in Ancient India and China

The mystery of the use of iron in India and China is one that largely baffles modern metallurgists. It is assumed that these countries developed iron and other metallurgical skills after the west, but the evidence points otherwise. Nikolass van der Merwe gives the orthodox view: “Spreading east from

the Mediterranean, iron was diffused throughout most of Asia before the Christian era. By 1100 B.C. it was in use in Persia, from where it spread to Pakistan and India.

The date of the arrival of iron in India is still a matter of some dispute; until recently, iron was assumed to have reached Northern India around 500 B.C., where it appears at the sites of Taxila, Histinapura, and Ahichatra in association with the distinctive ‘Northern Black Polished’ pottery type. Recent excavations at Atranjikhera, in Uttar Pradesh, however, have uncovered iron artifacts in association with ‘Painted Grey’ pottery, from an earlier period of the Ganges civilization, and have been dated between 1100 and



A Hittite stele from central Turkey

1000 B.C. Further archaeological work will be necessary to gauge the impact of iron-working knowledge on Northern India, especially regarding the forces which contributed towards the urbanization of the peoples of that area. In the southern part of India, at least, especially in the Deccan, iron seems to have stimulated a veritable ‘revolution’ of this kind.

“The transmission of iron-working knowledge to China, if it took place at all, is a problem which remains unsolved. The possibility exists that iron was carried to China by the nomadic tribes of the Eurasian steppes. During the latter half of the first millennium B.C. the Sarmatians, a tribe closely related to the Scythians, are known to have occupied the region adjoining Kansu, in Northwest China. The Sarmatians relied primarily on bronze as a source of metal, although using iron to a limited extent. Their penetration to Northwest China is marked by the appearance of their distinctive ‘Animal Art Style’ in Mongolia and Ordos, where it is dated to circa 500 B.C.—and possibly earlier. Since iron appears in China during the sixth century B.C., and perhaps earlier, it is doubtful whether the Sarmatians did, in fact, carry the knowledge of iron to China. If they did, it was at best a case of stimulus diffusion, since the Chinese did not adopt the direct process, which had been the exclusive method for the

Continued on Page 68

ATLANTIS RISING MAILING POLICIES

A regular subscriber to Atlantis Rising (for either 6 or 12 issues) is mailed each new issue directly from the printer at the time of publication. Address labels go directly on the cover, with no additional packaging. Such mailings are sent 4th class to the U.S. postal system only.

In the past when customers have expressed interest in foreign subscriptions, or in receiving their U.S. subscription by first class mail in an envelope, we have been unable to comply. Unfortunately, the handling requirements for such services were beyond our means to deliver. However, we are happy to report, that situation has changed. **We can now offer FOREIGN and FIRST CLASS U.S. SUBSCRIPTIONS (to be airmailed in envelopes within a few days of publication).** These subscriptions will be charged the additional regional flat rate for postage required, plus a service charge to cover the envelope and office expenses which we incur in order to provide these services on a relatively small scale. Should we experience sufficient demand, we may at some time be able to reduce the service charge.

Subscription Category	additional postage per iss.	service charge per iss.	Total Subs Charge
Regular U.S. (4th class, no envelope)			
6-issues	0	0	\$ 24.95
12-issue	0	0	40.00
First Class U.S.			
6-issues	\$ 1.50	\$ 1.50	\$ 42.95
12-issues	1.50	1.50	76.00

Existing regular U.S. subscribers wishing to convert to first class, may do so by sending us an amount equal to \$3 for each of their remaining issues. To determine the proper amount call our toll free number at 800-228-8381 during business hours (mountain time) Monday through Friday.

Canada (airmail only)			
6-issues	\$ 1.85	\$ 1.50	\$ 45.05
12-issues	1.85	1.50	80.20
Mexico (airmail only)			
6-issues	\$ 3.00	\$ 1.50	\$ 51.95
12-issue	3.00	1.50	94.00
Western Hemisphere (Except Can. & Mex.) (airmail only)			
6-issue	\$ 2.75	\$ 1.50	\$ 50.45
12-issue	2.75	1.50	91.00
Europe (airmail only)			
6-issue	\$ 3.60	\$ 1.50	\$ 55.55
12-issue	3.60	\$ 1.50	101.20
Asia & Africa (airmail only)			
6-issue	\$ 4.25	\$ 1.50	\$ 59.45
12-issue	\$ 4.25	\$ 1.50	109.00
Pacific Rim (airmail only)			
6-issue	\$ 4.65	\$ 1.50	\$ 61.55
12-issue	\$ 4.65	\$ 1.50	113.80

In some areas those interested in lower prices and willing to accept later delivery can contact these distributors:

For Europe and the British Isles:

Frontier Science Foundation
P.O. Box 372, the Netherlands

E-mail: fsfflco@glo.be

For all other locations:

Adventures Unlimited

P.O. Box 74, Kempton, IL 60946

E-mail: auphq@frontiernet.net

Foreign orders for other products which we sell will have the appropriate postage added to the bill with no additional service charge (our overhead costs have already been included in our shipping and handling charges). In the case of back issues, foreign orders will be charged an additional 50¢ per issue plus the appropriate postage.

ANCIENT MYSTERIES

“ If the radiance of a thousand suns were to burst into the sky, that would be like the splendor of the mighty one ...”

Thus spoke physicist Robert Oppenheimer, director for the Los Alamos Scientific Laboratories in New Mexico and leader of the Manhattan project and father of the atomic bomb.

Speaking later in an interview at Rochester University, when asked whether the test in New Mexico was the first atomic bomb, he replied, “Well yes... in modern history.”

Ancient Texts

Perhaps we have learned something. Since the bombing of Japan to end WWII, people shrink from all-out war. While terrorist activity continues worldwide, major war between the United States and another first or second world nation, seems all but obsolete.

Nevertheless, researchers say that enough nuclear weapons remain stockpiled world wide to blowup the planet many times over.

Can we really destroy the earth? Or how about just a continent or two ... ? It seems that this very scenario may have played itself out in our own past history. It's hard to say exactly when these things occurred, but it's thought by many to have been about the time of the ending of the last 'ice-age'—around twelve thousand years ago.

We owe much of our suspicions to the ancient texts of India—mythic tales dating back thousands of years ago and preserved by oral tradition, until finally written down in Sanskrit, the ancient sacred language of India and Tibet. They remain some of the oldest books in the world.

Their epic stories tell of horrific wars and mass carnage on a phenom-

enal scale. Great fire-balls that can destroy a whole city—and burn fifty thousand men to ashes in seconds. (Not usually considered withing the capability of the ancients.)

Most historians believe that our ancestors of that time lived in caves. Men and women of that period, we are led to believe, were not very intelligent and did little (we are told) except hunt or sit around the campfire carving arrowheads.

Ancient Indian epics, however,

rienced it for themselves? How are they able to speak of the brightness, the quaking of the earth, the wind, the roar ... ?

From Indian texts like *the Parvas*, *the Rig Veda* and the *Ramayana* (to name a few), we find other startling excerpts: “They stand above the airy region and shot the deadly missile.” One passage begins. Blazing shafts pierce the air filling the sky like the rays of the sun. With “A great soaring sound in smoke and flames,” the “iron thunder-

bolt”, described as “brilliant and powerful” roars and shakes with such ferocity that the blast makes the “mountains rock and reel.”

Fountains of the Deep

In many cases throughout Indian mythology, fiery destruction is followed by flooding and torrential rains on a grand scale. Even the mountains quake and crumble into the sea—letting the floodwaters spill over onto the land. Everything is destroyed.

Interestingly, many of the flood legends that abound in all corners of the globe are preceded by a destruction of fire. Virtually every ancient culture has a Noah story—a good person is warned to collect seeds,

Could Atomic Weapons Have Played a Role in the End of the Last Ice Age?

WAS THERE AN

ANCIENT
ARMAGEDDON

BY SYLVIA DAILEY

paint a much different picture. Consider this scene from *the Mahabharata*:

“Gurka, (an Indian god), flying a swift and powerful vimana, (air ship), hurled a single projectile charged with all the power of the universe. An incandescent column of smoke and flame, as bright as ten thousand suns, rose with all its splendor.

Incandescent columns? ... or maybe the blinding stem of a mushroom cloud. Scholars and scientists have paid quite considerable attention to these passages since we invented the atomic bomb.

The important question is: How were the ancients able to describe—in detail—the characteristic pattern of an atomic detonation, unless they'd expe-

animals, friends, family, etc., and put them on a boat. (Some versions tell of people who are instructed to head for the high hills—pronto.) Pictures in children's story books that show the animals lining up two-by-two in front of the ark are depicting nothing less than a mass evacuation.

It's also interesting to note that the Hebrew version of the flood story, which comes to us through the book of Genesis, is not an original one.

It appears that there was some cross-pollination between the dynastic Egyptian culture and the older Sumerian culture in terms of history and mythology. Some old clay tablets covered in cuneiform writing from Iraq give an extremely old version of the flood story. In the “Epic of Gilgamesh,”

a man warned by the gods to build a big boat saves all the animals. As a reward he was granted immortality.

Some speculate there was no worldwide flood... But common sense suggests that when people on every continent (except Antarctica), and many remote islands, relate flood legends, something worldwide must have happened.

Stories of flood, fire and catastrophe often include strange and erratic celestial happenings. The sun, for example, is described at times as dancing in the sky. Things become confusing when the sun rises in the west... and sets in the east.

Such phenomena offer clues about the stability—or instability—of our planet. If the sun and the stars are gyrating in the sky... perhaps it's not the heavens, but our planet that's dancing.

How can this be?

One theory which makes a lot of sense is the Earth Crust Displacement theory. In other words, the entire surface—or outer shell—of the planet somehow became dislodged, sliding around over the gooey inner layer of liquid lava.

According to this theory, the great abundance of ice on North America was because... North America was originally at the North Pole! Then when the earth's outer skin slipped around, animals living in warm areas suddenly found their homes shifted up into the Arctic Circle. North America was shifted out of the frozen

zone, and consequently the ice cap—all those glaciers of frozen ice—began to melt, creating the end of the ice age.

What caused this shift? No one really knows, but many have ventured to speculate. Some say that the tremendous weight of the ice buildup at the poles caused instability in the planet's rotation—resulting in a pole shift. Others think that alignments of planets and stars are to blame. Still others say that a comet or meteor strayed too close and threw earth out of balance.

But... I wonder, could calamitous events as a pole shift be caused by the detonation of ancient nuclear arsenals.

Archaeology Speaks for Itself

According to an article in the *New York Herald Tribune*, archaeologists digging in Iraq in 1947 uncovered an agrarian culture dated at 8000 years. Digging further, they unearthed the scant remains of a herdsman culture that was even older—much older. As they continued to dig, they eventually came upon an even older, cave-man



Krishna and Arjuna in battle as depicted in the new English translation of the ancient Sanskrit epic Mahabharata (Torchtlight Publishing, 1999).

culture. When finally they reached a level beneath the cave-man debris, they discovered something most unusual—a layer of greenish glass. They didn't know what to make of it.

Pretty soon, in other parts of the world, other scientists were uncovering these deep layers of weird greenish glass also. The 'Holy Lands' of the Bible on the eastern side of the Mediterranean Sea was found to have a deep layer of green glass. Then in parts of Africa, the Gobi desert in northern China and even down in Australia, archaeologists were uncovering this weird greenish glass. No one knew

what it was.

At least they didn't know what it was until the United States military began testing atomic bombs in the desert sands of Alamogordo, NM. People at the test sites began to notice that after the bomb did its thing, teams of researchers went over the blast area and at the epicenter where the fire ball had formed was a strange greenish

glass. It was soon determined that the green glass was where the bomb's overwhelming heat had actually melted the dirt.

Only intense heat—as in an atomic blast—will fuse the silica in the sand and dirt and form this green glass.

Another strange phenomenon which archaeologists unearthed was the effect of vitrification on many ancient stone temples around the world.

When for stones to be vitrified they must be heated to such a high temperature that they actually melt and fuse together. No ordinary campfire or any other common fire we'd imagine primitives to use would get hot enough to melt stone. In fact, it wouldn't get anywhere near hot enough to melt it. Melting and fusing stone blocks requires extremely high heat... so high, in fact, that the whole idea poses serious problems for many traditional archaeologists.

Generally, for vitrification of stone blocks to occur, experts say that you would need the kind of heat most associated with atom bomb explosions.

One of these vitrified areas is located in India between the Ganges and Rajmahal mountain ranges. The city had been subjected to such intense heat that masses of the ancient walls and foundations have been literally cooked and fused together.

Another area of vitrified city ruins is in Turkey. The ancient and somewhat mysterious people who lived in this region were the Hittites. And aside from a few remarks about them in the Bible, we know little about them.

Continued on Page 70

Better Research. Better Ingredients. Better Price.



That's Why DOCTOR'S BEST Supplements are the BEST!

QUERCETIN BROMELAIN

Fight Back Against Allergies

Quercetin Bromelain contains pure, undiluted quercetin, one of nature's most active and versatile bioflavonoids. Quercetin is known for its ability to support the body's function of stabilizing unwanted responses to foods and the environment. Bromelain, a plant enzyme derived from the pineapple stem, delivers soothing benefits as it supports quercetin absorption.

180C \$24⁹⁷



ULTRA GUGGULOW

Get Your Cholesterol Where You Want it and Keep it There

"An ancient insight leading to a modern discovery," describes the story. Ultra Guggulow contains a standardized extract of gum guggul, an herb prized throughout the far east for centuries. The famed Ayurvedic healers of India wrote about its virtues as early as 600 B.C. In 1964, Indian medical researchers began a series of clinical studies showing that gum guggul effectively controls blood cholesterol. Ultra Guggulow is guaranteed for potency of "guggulsterones," key ingredient (25 mg.). Also contains Bioperine®, the herbal extract that boosts absorption.



90C \$25⁸⁵



BRAIN POWER ENHANCER

Fight Back Against Age-Related Memory Loss! Brain Power Enhancer Recharges Your Brain Cells. So You Think Sharper, Faster and Enjoy Better Memory!

Recharge Your Brain Cells and Fight Back Against Age-Related Memory Loss with Brain Power Enhancer!

Don't watch your memory and mental function slip away. Regain your brain power with Brain Power Enhancer, a powerful new combination of two ingredients that recharge and renew your brain cells. Bacopin™ an Ayurvedic herb extract, helps renew brain cell membranes with a gentle relaxing effect on the mind. This special herb (*Bacopa monniera*) has been esteemed as a brain tonic for centuries in the herbal traditions of the far east.

Phosphatidylserine revitalizes cell membrane functions that keep your thinking clear, your mind alert and your memory sharp. Over 30 research studies, including 14 double-blind trials, show taking phosphatidylserine improves memory, recall and cognitive ability in people with age-related memory loss.

Experience a whole new level of high-powered brain function with Brain Power Enhancer. Each capsule supplies 50 mg of Bacopin™ plus 50 mg of phosphatidylserine from 250 mg of LeciPS®.

60C \$22²⁰

High Absorption CoQ10

CoQ10 Helps Keep Your Heart Strong and Healthy! But, It's Hard to Absorb. We **Solved** that Problem and Call It High Absorption CoQ10

It is a basic fact of biology that cells need CoQ10 to produce energy. With its high energy requirements, the heart is especially dependent on this vitally important nutrient. The body's ability to produce CoQ10 falters as we age, which means we need a good CoQ10 supplement to make up the difference. But CoQ10 is a fat-soluble nutrient, so it may not always be well-absorbed. High Absorption CoQ10 solves the problem with Bioperine®, an herbal extract that enhances CoQ10 absorption. Now you can take a high potency CoQ10 supplement and know you're absorbing the CoQ10 your heart needs to stay strong and healthy, when you use High Absorption CoQ10.

100 mg 30C \$21²⁰

TO ORDER Send check or money order to:

Atlantis Rising • P.O. Box 441 • Livingston, MT 59047

For Credit Card Orders Call Toll Free:

800-228-8381

Glucosamine/Chondroitin/MSM

At Last! The Joint-Saving Benefits of Glucosamine, Chondroitin and MSM All in One Supplement, at a Price that Can't Be Beat!

Glucosamine sulfate, chondroitin sulfate and MSM are three of today's most widely recommended dietary supplements. And with good reason. Each has been proven to help improve joint health and function. And now, you can get clinically-effective intakes of all three in one product.

Save Money While You Save Your Joints!

Even better is the money you save, compared to buying these joint-saving products separately. Just four capsules per day supplies 1500 mg of sodium-free, potassium-stabilized glucosamine sulfate, 1200 mg of chondroitin sulfate and 1000 mg of MSM. So, if you want a complete program for restoring joint health and strengthening all the body's connective tissues, take glucosamine sulfate, chondroitin sulfate and MSM every day. But don't put yourself through the inconvenience and expense of three separate products. You can have them all—at a very good price—in Glucosamine/Chondroitin/MSM.

120C \$31⁴⁰

Please add \$4.95 S.&H. to each order (no matter the quantity)

To see more fine DOCTOR'S BEST products and to order on line, visit AtlantisRising.com



Judy Jacka, N.D.

Plugging in to Mother Earth

Physician Judy Jacka Shows the Way to Healing through Earth Energies

Wouldn't it be great to enjoy the benefits of adulthood while still keeping an umbilical cord to a loving mother who could soften the blows of life and keep us constantly nourished? According to the late Canadian researcher Fran Nixon, we all have just such a connection to Mother Earth. Australian Naturopath, Judy Jacka, studied Nixon's work and was so impressed that she has incorporated it into her repertoire of healing techniques and has written an impressive book of her own called *The Vivaxis Connection—Healing Through Earth Energies*. Her fifth book she describes as having been the most difficult to write, due to "the unusual and complex nature of Earth energies."

A Vivaxis, or "life axis" is a sphere of energy established at a geophysical point which connects with the growing fetus some time within the last two months of pregnancy. Technically, it is a sudden fusion of forces that are grounded to the Earth, usually through a solid that is a suitable conductor. The atomic particles within the Vivaxis energy sphere become aligned and magnetized to the geophysical field in which it is created. This magnetizing of energies causes a wave link to be established between the Vivaxis and its "owner."

Each of us is thus linked in a life-long, two-way circuit to the earth via his or her individual Vivaxis; Nixon postulated that our life force rotates around this central point and that, through this unique connection to the

Earth, we can literally "plug in" to its life-supporting energies. The location of our Vivaxis is usually near our birthplace; however, the actual placement depends on where our mother was when it was formed. According to Nixon's research, a permanent magnetic alignment to this location on the planet is introduced into the atomic structure of our bones as they solidify before birth. Jacka suggests this is because our skeleton is the most stable part of our physical body.

Growing up in Melbourne, Australia, Jacka became interested in holistic health while very young. She left formal education at 16, then worked for two years at a hospital laboratory in gynecology and hematology. In 1960, she earned her nursing degree at Saint Henry's Hospital, married, and started a family. Disillusioned with the medical model, she pursued what little material on alternative approaches existed in Australia in the '60s. "I was interested in the Bircher-Benner's work with diet in Swiss sanitariums," she says. When a course in naturopathic training was offered (run by the man who later became her second husband), Jacka enrolled "with some doubt." She found the course "feeble" and worked to help build it up to the caliber of a standard science degree. After pursuing a post-graduate course at Melbourne University in Human Relations Education, she continued her personal research into health and healing, and worked to establish The Southern School of Natural Therapies with the aim of offering masters' programs on a par with those offered at universities. Today, after seeing close to 30,000 patients and training many students, Jacka is proud to say that "What began as dissatisfaction with my nursing training has grown into something of a national movement and, though many of my former students now outclass me educationally, I have the pleasure of knowing I helped start

the holistic health movement within Australia on a big scale."

Though learning the Vivaxis techniques is somewhat complex, Jacka is confident that "anyone who puts about twenty hours into it can become proficient enough to use them effectively." Her experience has shown that most people can get the basic rudiments in a four-day course. "It is a very precise science and is difficult to learn without an instructor," she admits. "It's like a new language and, unfortunately, there are no comparative texts to help the student." Perhaps more unfortunately, there are no practitioners of Vivaxis in the United States at this time.

One of the most important concepts Jacka tries to convey is the understanding that Vivaxis energies contain health-giving frequencies found in layers throughout the planet. Generally spaced 16 inches apart, the layers are like onion skins, each containing ten distinct bands; the central bands contain four "force flows," which hold the frequencies of particular minerals. All of the layers contain frequencies needed by the human body and are very specifically coordinated with one another.

Some layers are continually present, while others "wax and wane" throughout a 24-hour period. Though finding the layers and learning which frequencies correspond to which minerals (there is also a "vitamin" band) is complex, Jacka simplifies it by pointing out: "The basis of Vivaxis is that there are frequencies we can contact on the surface of the earth, received via the Vivaxis sphere of energy, and that we have techniques to remove any impediments to this connection."

One of these techniques is to align our bodies in the direction of our Vivaxis. Jacka likens this to "tuning into your own personal radio station." While it is not necessary to find the

Continued on Page 71

■ BY CYNTHIA LOGAN

SEE OUR GREAT 8-PAGE CATALOG SECTION BEGINNING ON PAGE 74

Number 26 • ATLANTIS RISING 45

How does a laser physicist working for the CIA find his way to a spiritual awakening? Russell Targ, Ph.D., has made that journey from materialist/reductionist to psychic spy to spiritual seeker, and speaks openly about it.

Targ's psychic experiences began even before he did remote-viewing—the skill by which people envision distant places, activities and times. The ESP work was supported by the CIA and other agencies for 20 years; governments want to use mind-to-mind connections for “defense.”

Later, after a diagnosis of cancer, Targ learned firsthand about spiritual healing—different than psychic healing. A sub-category is spiritual healing at a distance. He believes that both remote viewing and distant healing are manifestations of “nonlocal mind.” Mind cannot be confined to points in space such as brains and bodies, nor localized to points in time such as the present.

Healing

Russell Targ is a tall man, slightly stooped in posture, exuding both the dignity of a well-known researcher recently retired as a senior staff scientist for Lockheed Martin and the joy of ongoing discoveries. He peers at the world through thick glasses, but poor physical vision only seems to sharpen his other faculties. In San Francisco over dinner I met Targ and his daughter, psychiatrist Dr. Elisabeth Targ, before he gave the final speech in a series that Elisabeth organized for a hospital staff.

Her own research findings support her father's growing knowledge of the role of consciousness in healing. For example, a mainstream peer-reviewed medical journal (*The Western Journal of Medicine*, 169, December, 1998, pages 356-363) published Fred Sicher, Dr. Elisabeth Targ and others describing a study of distant-healing on a group of men with advanced AIDS. The treated group had fewer severe new diseases and fewer hospital visits and significantly improved feelings of health. The researchers suggested that experienced healers around the U.S.A. could medically benefit a targeted group of AIDS patients in as short a time span as ten weeks.

■ BY JEANE MANNING



Exploring the Frontiers of Consciousness

*For Russell Targ and Jane Katra
the Real Journey Is Inward*



Jane Katra and Russell Targ

Everyone knows that an invisible mind moves your physical body and tells it when to tighten muscles or to breathe expansively. What is news is the *power* of mind by which thoughts create effects at a distance.

Co-Authors Targ And Katra

Russell Targ and Jane Katra, another Ph.D., write books about this psychic Internet—Jung's collective unconscious. Targ and Katra call it our community of spirit. Users hooked up to this exchange-of-information are those people who have learned to stop their thoughts and rest their attention.

Jane Katra also came from a culture of conventional intellectuals and never expected to be outside it. Her story is told in Katra and Targ's 1998 book *Miracles of Mind: Exploring Nonlocal Consciousness and Spiritual Healing*. Her doctorate is in health education, and she taught at the University of Oregon. At the end of a long trip in Southeast Asia in 1974, she was struck with an excruciating headache and then a near-death-like dream. During the inner experience, Katra was told that she would become a healer. To her dismay, the prophetic instructions were correct. Back home, university

colleagues and family became uncomfortable with the new Jane, but she had to honor the gift by using it to help people. As the doors to academia closed for her, she found other methods for earning her living without charging clients for the healings. Life then opened new doors, such as the parapsychology conference where she met her friend Russell Targ.

Remote Viewing

Targ and Hal Puthoff, Ph.D. co-founded the once-secret remote viewing program at Stanford Research Institute. Katra and Targ's book is the first to publish some of the declassified drawings of that work, obtained by Targ under the Freedom of Information Act. The classified experiments had been first supported in 1972 by the CIA, joined in 1995 by other agencies including the Defense Intelligence Agency, the Army, Navy and NASA.

One of the most amazing examples of the covertly funded remote viewing that penetrated the Iron Curtain was the work of a talented police officer, Pat Price. He was given only the latitude and longitude of what turned out to be a secret Soviet atom bomb lab in Siberia. Without knowing any more than the coordinates of the target, he precisely sketched the buildings and an unusual large crane that was later

verified by satellite when it was moved outdoors—after Pat Price's death.

Targ was usually the interviewer, in an electrically shielded room where Price and other viewers tuned into a distant target. Psychically they would track the whereabouts of Puthoff as he traveled in other countries. Price would describe and sketch an assortment of volcanic mountains, marketplaces and churches, for example, and later they would learn the specific locations in a country such as Costa Rica where Puthoff had been at the times recorded on Price's drawings.

One day Price didn't show up for a scheduled experiment, so Targ did the remote-viewing trial himself. Although his psychic experiences began at university while performing as an amateur magician, he hadn't taken part in a formal experiment before. He started the tape recorder, closed his eyes and saw what looked like an airport with a runway leading to the ocean. He sketched a building on the left and grass and sand on the right. Later, he saw the photo of where Puthoff had been at that time—a matching airport on an island off the coast of Colombia.

Remote viewing is not mind-reading, because viewers often see things that are unknown to anyone else at the time. *Miracles of Mind* gives the how-to for readers to try remote

viewing with the help of friends.

Data that proves the interconnectedness of consciousness can help us see the interdependence of humankind and how it can be used for survival instead of weaponry. Targ believes that the knowledge should be available to humankind.

On the negative side, Katra and Targ describe some of the past Russian psychic experiments, and find them disturbing. Reverence for life was missing.

In 1992, Russell Targ was pale and losing weight. CAT scans and x-rays showed spots on his internal organs that medical doctors said was metastatic cancer. They instructed him to put his affairs in order and begin chemotherapy very soon. Instead, he asked Jane Katra to work with him as an immune-system coach and spiritual healer.

She intuitively knew that he should not empower the concept of saying he was sick. As well as spiritual healing and affirmations, she explored with him how he could "change the host so that the disease could no longer recognize him." Attitudes, emotional expression and social connections were changed. Targ tried unfamiliar behaviors: early-morning jogging, giving

Continued on page 73



If you do not see Egypt through "Symbolist" eyes You do not see Egypt at all...

John Anthony West, leading exponent of the 'Symbolist' school of Egyptology, author of *Serpent in the Sky: The High Wisdom of Ancient Egypt*, *The Traveler's Key to Ancient Egypt*, and Emmy Award-winning creator of the NBC special *Mystery of the Sphinx* has been personally leading intensive 16 day study tours to Egypt for over 15 years.

Also announcing: The Ancient Wisdom Foundation, a not-for-profit educational organization created specifically to further research into the reality of sophisticated ancient civilizations long predating those of Egypt, Sumer and India.

For detailed information on trips to Egypt and the AWF:

Website: www.jawest.com
Email: jawsphinx@aol.com
Tel: 518-945-2160
Address: P.O. Box 22; Athens NY 12015

Personally autographed copies
of the books of
John Anthony West.
Limited quantities available.
Order now, in time for Christmas.

1-800-228-8381

for S&H Add \$4.95 for 1 item and
\$2 for each additional

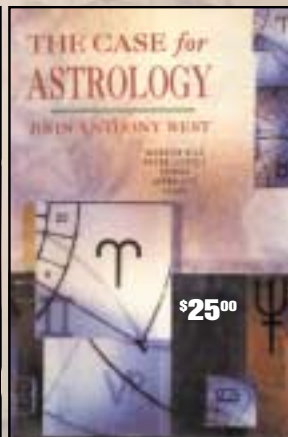
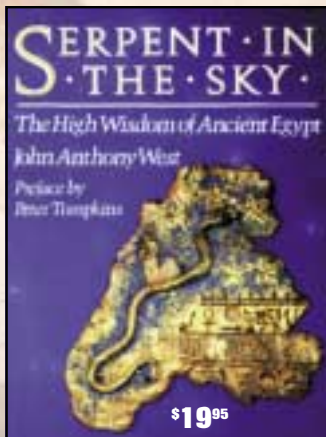

Sirius and the New Atlantis

Can the Chart of the United States Tell Us Anything About the Last Days of Atlantis?

Some have suggested that the United States and a majority of its people are Atlantis come again. If that is so, then what can astrology tell us about what might have gone wrong—or right—the last go ‘round, and how might we apply those lessons to “get it right” this time?

What actually happened in the last days of Atlantis? What state was the government in just before its destruction? In what condition were its political, military and commercial systems? Was it one of greed, selfishness, hidden interest groups subverting the general good? Were the people taking prosperity for granted—misusing its gifts—or were they outpicturing benevolence and good will towards all? Or was Atlantis—like America—a bit of both?

Are these questions that astrology might unravel?

Some think so. After all, a nation—like an individual—also has a birth chart. It is called a mundane chart (mundus, meaning “world”), and you read the chart as you would a person’s to learn clues to destiny and character traits. A nation has a personality, (ascendant), a power focus, or head (the tenth house), open enemies and close allies, a place where assets are merged

■ BY CHRISTINE BARRERE

48 ATLANTIS RISING • Number 26

If Sirius is favorably connected to another planet, such as the United States Sun, there is a Sirius influence emanating from that person or country. An element of divine positioning, protection, overshadowing, and guidance accompanies this Star.

with others. A nation can even have a past life.

The death constellation in one incarnation carries over to the birth constellation in the next, allowing a person (or country) to continue with its patterns, obligations and lessons. Whether a person or a nation, we can discern the attainment and the unfinished business by examining the birth chart, and where it left off in another time. In the birth chart of the United States are the clues to its past as well as its attainments and its shortcomings.

The procedure for creating such a chart is exactly the same as with an in-

dividual’s chart. The date most astrologers use for the birth of the United States is July 4, 1776. This puts the United States Sun in Cancer at 13 degrees. A Cancer Sun represents nurturing, protecting and an abundance of emotional and physical concern for the well-being of others. Cancer is the sign of the family and home.

The United States’ Sun at 13° Cancer conjoins the fixed star, Sirius—a very important star for many reasons. These two conjoined is a blending of the two energies. So, America’s Sun is influenced by Sirius’ personality.

Lore has it that Sirius is considered to have an influence similar to the blending of Mars and Jupiter. A sort of energized benevolence and protection. The attributes of Jupiter include high ethics, right judgment, highest good, morality, and a Godlike ability to bestow blessings, imparting wisdom and guidance to those evolving under its care. These qualities, combined with the driving power of Mars to have action implemented, to the astrologer are similar to those of Sirius.

The name “Sirius” comes from the Greek “oeplos” meaning ‘scorching, or ‘fiery’. In Arabic it is Al Shoal, the Gleaming One.

It has also been said that the star takes its name from the Egyptian God-

dess Isis and it has been also called the "second sun." John Anthony West considers Sirius important in Egyptian lore, figuring prominently in the funerary texts which illuminate the individual's transformational spiritual activities. If Sirius is favorably connected to another planet, such as the United States' Sun, there is a Sirius influence emanating from that person or country. An element of divine positioning, protection, overshadowing, and guidance accompanies this Star.

One of the more interesting suggestions regarding the meaning of Sirius comes from the West African "Dogon" Tribe. As Robert Temple has explained in his books on "The Sirius Mystery," the Dogon had a deep knowledge of cosmological, astronomical and mythological lore. They knew Sirius was a binary star with an invisible counterpart called Sirius B. Before modern telescopes and technology, they knew of Sirius B (which was detected in 1962 by astronomer Alvin Clark).

It is thought by some, including Temple, that extraterrestrials educated this tribe about astronomy and accelerated their culture in laws and governing.

The Egyptian glyph for the star Sirius is "to be prepared" or "to be equipped with appropriate means." Also the meaning of "star" is "door, or

to pass through a door."

The star symbolizes a sacred sanctuary of order, community, organization and seeks to bestow brightness—the mundane in process of becoming sacred.

In Princess Diana's Chart, Sirius culminated on her Sun in Cancer and provided, some would say, an example of a soul somehow immortal and sacred. Her popularity and grace may not have been so extraordinary had Sirius not been on her Sun. A person (and/or country) thus aspected doubtless "feels" a special accountability to protect and liberate others.

This star's influence in certain horoscopes marks immense creative talent in almost any field, but not, however, without danger. The individual (or country) with a prominent Sirius holds power which could be misused and might have more intensity and influence that can be handled properly.

The United States is heavily influenced by Sirius, giving it power over things, other people and nations. This responsibility might explain what some like to argue is an almost compulsive interference in the affairs of other countries, especially where suffering or injustices are prevalent. Such influence can create trouble if the energy is misdirected.

The United States natal Sun and

Sirius are in a "square" with Saturn, signifying strict obedience to laws and justice, balance and facing realities at hand. It also shows why its leader must transmit an ethical and moral message to the people and be strong in his own sense of self governing.

The Saturn square Sun suggests collective negligence in many areas—food distribution, protection of our borders, taking care of the less fortunate, making responsible uses of our abundance, and the application of common sense in many areas.

The Saturn square Sirius implies that we have been negligent as a country in past times, to be 'equipped with appropriate means' and have failed to be the 'the bright and scorching light,' which beckons us and others to 'pass through the door' to a higher state.

Saturn square Sun represents the process of learning the right use of resources. The square implies a misqualification of Cancer's good intent of such severity that cataclysm might follow. Has the country Atlantis been waiting patiently beneath the ocean—waiting for another time, another cycle to emerge once again as the United States and pick up where it left off. This time, hopefully, it will not make the same mistakes again but rather, it will complete its divine purpose. ■



HERBAL HEALER ACADEMY Inc. since 1988!

**"EFFECTIVE, SAFE, NATURAL MEDICINE & QUALITY
CORRESPONDENCE EDUCATION"**

FREE Lifetime Membership in the Herbal Healer Academy

YOUR BENEFITS INCLUDE...

CORRESPONDENCE COURSES - in Herbal Medicine, Foot Reflexology, Acupressure, Bach Flower Remedies, Hypnotherapy, Vibrational Medicine, Nutrition and more...

All courses credit to our ND (Naturopathic Doctor) program - ANMCAB approved

ON LINE SUPPORT - for our members from Dr. McCain - a naturopathic doctor dedicated to helping you stay healthy using natural products. Specializes in "incurables!"

90 PAGE CATALOG - Featuring thousands of natural products, oils, bulk herbs, herbal tinctures, homeopathic medicines, books, videos, hair analysis, vitamins and much more...

PREFERRED MEMBER SPECIALS - Specials on our *exclusive* 4-Herb Caisse formula, ESSIAC™, Shark Cartilage, DHEA, 500ppm Colloidal Silver, Parasite formulas, homeopathic detox program, Colon cleanser, COQ10, & more...

NEWSLETTER - - testimonials, on-going research, new products...

LIFETIME - Laminated member cards - Copy - Nature's Cure for Cancer Story, plus recipe.

FREE - LIFETIME MEMBERSHIP SPECIAL WITH THIS AD (\$20.00 value) CALL TO-DAY!!!

Call, Fax or sign up for FREE on the web site.

CALL - 870-269-4177 - FAX - 870-269-5424 or (<http://www.herbalhealer.com>)

BOOKLET AVAILABLE ON THE WEB - Check out Radiation Poisoning Bulletin at our web site!

The ESSENTIAL ALTERNATIVE SCIENCE BOOKSHELF

INFORM YOURSELF

ELECTROGRAVITICS SYSTEMS

Reports on a new propulsion methodology

Edited by Thomas Valone, M.A., P.E.

Compiled into one book for the first time: secret history and technology of the B-2 Stealth Bomber; how the B-2 can fly with zero fuel consumption indefinitely; actual use of the EPU's, exhaust ducts, and large wingspan; early T.T. Brown experiments which sparked the research; Complete Aviation Studies, Ltd. electrogravitics reports; "The U.S. Antigravity Squadron" by physicist Paul LaViolette; "Negative Mass as a Source of Energy" by physicist Banesh Hoffman; collection of electrostatic and electrogravitics patents.

130 pages 6x9 paperback black and white illustrations **\$1500**



THE HOMOPOLAR HANDBOOK

A definitive guide to Faraday Disk and N-machine technologies

Thomas Valone, M.A., P.E.

The mysterious Unipolar Dynamo, so simple that even the earth's core has one, so powerful that it forges a metal alloy billet and launches a rail gun!

The Homopolar Handbook has all the history, operating principles, practical construction details, and pictures of Faraday disk/unipolar/homopolar generators.

Investigating the Paulsen UFO story and the DePalma claims of overunity, the author began an earnest scientific endeavor in 1980 to build and test a homopolar generator (HPG) for the elusive "back torque" which had never been measured before in a one-piece HPG. This project helped complete his Master's Degree in Physics at SUNY Buffalo. What does the torque push against when the magnet spins with the disk? How can the back torque or armature reaction be diminished or counteracted? These and other burning questions are answered in the only book of its kind on the subject of homopolar generators.

188 pages 6x9 paperback • black and white pictures, illustrations and diagrams **\$2000**



THOMAS TOWNSEND BROWN: Bahnsen Lab 1958-1960

Electrogravitics Levitation Experiments

VHS Video



The only existing film featuring T. Townsend Brown working on his metallic saucer-shaped models which are powered by high voltage applied to separate sections.

Labeled "electrogravitics" by Aviation Studies Ltd. in 1956, such experiments were carried out by several major aerospace industries in the 1950's. Brown and Bahnsen each obtained several patents, during and after this period, on the designs seen in this video. Bahnsen seems to have pursued vertical lift designs, with the + voltage on top, while Brown focused on horizontal propulsion designs. These models lift and hover with electrogravitic forces in this film! Many different hemispheric designs are tested. Also seen is a Wimhurst generator and a short, fat Tesla coil, proving the necessity for high voltage in the operation of the craft. This film was originally called "Daddy's Lab" by Katherine Bahnsen, who filmed the segments with a Super 8 camera.

VHS • Color • Silent • 1 Hour **\$2000**



CONFERENCE ON FUTURE ENERGY

29 April - 1 May 1999 • CD Rom

This special edition CD-ROM features 4 days of a conference on future energy. 20 Speakers, 9 of whom are Phd's & 1 MD: 15 Audios (All Plenary Sessions) (.wav); 14 Audios (All Workshop Sessions) (.wav); and 23 Papers Published in Adobe Acrobat (.pdf). Just a few of the speakers and guests include: Thomas Valone, MA, PE. "Understanding Zero Point Energy" Ken Shoulders, "Charge Clusters in Action" Dr. Paul Brown, "Betavoltaic Batteries", Kent Robertson, "The Coming Energy Revolution from Wind", David Wallman, "Carbon-Arc Gasification of Biomass Solutions", Bruce Perrault, "Radiant Energy Generator", Dr. Ed Storns, "New Method of Initiating Nuclear Reactions."

Special video, "ECold Fusion: Fire from Water" and "Peroxide Helicopter Demonstration" **\$4999**

THE ZETA RETICULI INCIDENT • Terence Dickinson

Six years after its publication "The Zeta Reticuli Incident" remains one of the most controversial scientific UFO documents ever written. Focusing on a remarkable interpretation of a "star map", allegedly seen inside an extraterrestrial spacecraft, the article presented what is still regarded by many researchers as the most persuasive evidence yet that Earth is being visited by creatures from other worlds. This update by the author of the original article provides additional information on the star map and the importance of the work of Marjorie Fish, whose painstaking analysis resulted in the map's interpretation.

31 pages 8 1/2 x 11 1/2 paperback magazine • beautiful color pictures and drawings • black and white diagrams **\$1000**

Add \$4.95 s/h for one item & \$2 for each additional item

Send Check or M.O. to ATLANTIS RISING • P.O. Box 441 • LIVINGSTON, MT 59047 or call 800-228-8381

Hero of Flowing Nature

The Saga of Austrian Genius Victor Schauberg Continues to Amaze

From time to time in the true history of the world, which we ourselves do not write, is born a man to whom the term "hero" applies. Not hero as popularly used, as of a game, a struggle, calamity or even momentous event—but rather, hero in its deeper, classical, nearly forgotten sense of a being who undertakes and selflessly fulfills great responsibilities, who lives nobly, yet humbly, whose life reflects courage and especially, the pursuit of truth despite the consequences. Certainly, this is partly the inner meaning of the Oedipus myth, which serves well as a benchmark in one's own pursuit of truth. (Oedipus unknowingly killed his father, the Theban king, then subsequently married his mother. Upon discovering their true relationship, he blinds himself, and she kills herself.) A hero pursues truth above all, having committed himself to labor for the greater benefit of humanity.

However many people may surround him, the hero's life is lonely, for his commitment transcends ordinary concerns. And because success as measured in worldly terms has little meaning to the hero, his life cannot be evaluated by ordinary standards—some may demonstrate obvious, nearly debilitating imperfections.

Many facts concerning these men's lives would surprise, perhaps amaze us. These facts, and their impact on their lives, distinguish them from other great men, possibly heroes of lesser degree. To this august company of those men who strove to perceive clearly, who aimed to think insightfully, deeply, independently and thus unencumbered by conventional opinion and prejudices, must be added, I think, the name of Viktor Schauberg.

You can read about Viktor in *Living Energies*. Written by a broadly educated former architect, Callum Coates, the book was published in 1996 by

Gateway Books of Great Britain. Bookstores can still supply the book although it is possible that when these supplies are depleted, the book will go out of print.

Mr. Coates appears well-qualified to convey Viktor's subtle, detailed and iconoclastic thought. He reads and speaks German fluently, has been increasingly familiar with Viktor's writings and work since 1977 and he spent

three years with Viktor's son, Walter, a physicist who directs an institute in Austria. He also assisted in revising *Living Water* by Olof Alexandersson (reviewed in A.R. #8), a briefer, less inclusive book about Viktor and his work.

Viktor, who was born in Austria in 1885, and died there in 1958, qualifies as hero in every respect. His discoveries were so paradigm-shattering as to literally challenge the entire foundation of modern physical science—not just one or possibly two disciplines, but all of it. His own humility led him to write in the journal *Implosion* the following statement:

"They call me deranged. The hope is that they are right. It is of no greater or lesser import for yet another fool to wander this earth. But if I am right and Science is wrong, then may the Lord God have mercy on mankind." (pg. 28)

Events of the past 50 or so years since he wrote this have begun to show that Viktor was no fool and his apprehensions were well-founded. Our science and its stepsister, technology, are poisoning Mother Earth. Viktor's numerous discoveries, inventions and devices, for which he was granted many patents, performed as he anticipated. These demonstrations of the validity of his concepts and their practical efficacy, which occurred in Europe, aroused the enmity of the academic community—European scholars and scientists, never known for their open-mindedness, vilified him. Perhaps even worse, they galvanized established economic and governmental

forces, always bedfellows in impeding development, firmly against him: status-quo investments and control preclude "power to the people." Viktor, who believed that "Capital interest only thrives on a defective economy" (pg. 30), had in mind a sort of anarchy in its higher sense, not of lawlessness, but of individual self-governing, of voluntary cooperative association for the benefit of all.

This state would be made possible and sustained by easy access to the healthiest, purest, most wholesome water, by power (not only electricity) so cheap as to be virtually free and by an abundant supply of nutrient-rich food. Electricity generated in his home-power generator, Viktor said, would make nuclear fission "not uneconomical, but ridiculous" (pg. 12). All of this, by the way, without the many tons of radioactive (for 30,000 years) waste generated yearly by the dozens of nuclear power plants distributed throughout western Europe and without the yearly release worldwide of six billion tons of carbon dioxide gas into our atmosphere. Everything would be according to the principles established by Nature herself and thus without any negative repercussion whatever. Coercive government necessarily would be both smaller, less influential and intrusive into the daily affairs of everyone. A meritorious dream, is it not?

Living Energies contains technical discussion, as Mr. Coates did not intend just a biography. However, non-technically minded readers can greatly enjoy this book as well as prosper from reading it. Viktor, who described himself as neither "a technologist nor an engineer" said that "The highest wisdom is simple and passes through the brain directly into the heart" and, "Thoughts that have important consequences are always simple" (both pg. 31). Read carefully and where necessary, slowly, passing over the detailed material.

Here was a man, born into a family of generations of foresters, who somehow had discovered secrets discussed by the ancient Egyptians and many of the true spiritual leaders of the world. His insights were those of →



Victor Schauberg

■ BY DR. JOSEPH RAY

SEE OUR GREAT 8-PAGE CATALOG SECTION BEGINNING ON PAGE 74

Number 26 • ATLANTIS RISING 51

BOOKS

an elevated man, a man who saw through the veil of maya and that which is illusory to the underlying causative reality that brought it about. He appreciated that the "purely categorizing compartmentality" pseudo-education, already then in existence (and much further developed today) stultifies creativity and destroys the "ability to see things as they really are and thereby their connection with nature."

Over 40 years ago, Viktor considered the thought of modern scientists too primitive, too materialistic and, with regard to the origin of energy, essentially devoid of understanding. Interestingly, he found repeatedly in the traditional practices of small farmers in the various countries he worked in throughout Europe, just that understanding so glaringly absent in modern scientific thought. How did these deep (and to some, disturbing) insights first originate in Viktor's mind?

It all began in the Austrian forests where he spent thousands of hours over many years carefully observing natural phenomena and "energy exchanges." Why were trout in rushing mountain streams not forced downstream by the fast-moving current? And

capable even to rapidly swim upstream with the mere flick of the tail? Why didn't the water freeze at temperatures below -30 deg. F, 60 deg. F or more below freezing?

Watching moving water for endless hours, Viktor found his "free consciousness" was taken over by it, i.e., by the water's consciousness—water is a living being. "When my own consciousness was eventually returned to me, then the water's most deeply concealed psyche often revealed the most extraordinary things to me.... In this way I was able to experience things that had escaped other people's notice, because they were unaware that a human being is able to send forth his free consciousness into those places the eyes cannot see" (pg. 4). Viktor thus became the recipient of an ancient technique associated with elevated beings, masters and yogis. By means of it, knowledge hidden to most of us was transmitted to him. His connection with Mother Nature gradually was enhanced. Slowly, the mechanisms she utilized in her staggeringly complex economy were made known to him.

First he learned about water, its relationship to the earth and how we must relate to it if we are to receive all its benefits. Water is the earth's blood. It may be immature (e.g. rainwater) or

mature, vital or virtually devoid of energy. Rivers and streams cleanse themselves, revitalizing themselves by the meandering course they seek out. We, by straightening a river's course or especially by damming it, impede or inhibit this process entirely. By slowing the rate of flow or by storing water in large above-ground tanks, we raise its temperature, often far above the temperature at which it is most dense, energetic and healthful. This temperature, recognized but not appreciated in standard hydrology, is about 39 deg. F. This densest water will, therefore, float any object higher than the same water, somewhat warmer. It has other desirable qualities that diminish as the water warms.

There are many attributes and characteristics of water of which we are entirely ignorant. To quote Viktor, "Furthermore it is possible in this way... to produce drinking and spa water... of any desired composition... artificially, but in the way that it occurs in Nature; to raise water in a vertical pipe without pumping devices; to produce any amount of electricity and radiant energy almost without cost; ...to heal cancer, tuberculosis and nervous disorders" (pg. 108). Water in general, and pure, mature water especially, is a most remarkable substance whose ex-

**UFO SECRETS
OF THE U.S. GOVERNMENT**

As told by Sgt. Clifford Stone
U.S. Army (ret.)



audio & video cassettes
\$8.99 - \$19.99

510-540-6143
P.O. Box 256
Berkeley, CA 94701
www.GlobalViewCom.com
Global View Communications

**the Laserstones of
Portland,
Maine**



**ANCIENT
LASER-MADE
STONE
ARTIFACTS**

Dated to over
70,000 years"

www.laserstones.com

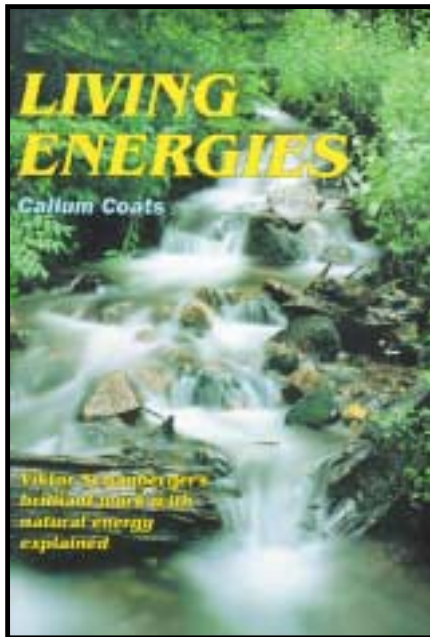

traordinary and unique properties underlies all life on this planet. Unwholesome, dead water can be cleansed and revived by adapting nature's methods.

Viktor developed a physical chemistry based upon his revelations. Of course, this system had little in common with then current (or contemporary) thought on these matters. He had to invent a descriptive terminology as scientific language had an unsatisfactory vocabulary and inadequate concepts for his system. Scientists bristled at his concepts, not only because they differed from the familiar but, I suspect, because they may have a dynamic quality to them, even, sometimes, the quality of sentience.

Gravity, said Viktor, was balanced by an opposing force, namely, levity: physicists laughed. Nature's way was centripetal (power-concentrating, as in a vortex), not centrifugal (power dissipating, as in a splash). Inherently friction-reducing, not friction-inducing, intrinsically contracting not expanding, accelerating, not decelerating, formative, not disruptive: these were Nature's methods in contrast to our own. Since nearly our entire modern system was at odds with Viktor's discoveries, and perhaps especially because many of these had been shown to work in controlled experiment and in real situations, he was regularly treated with derision. Can you imagine that a serious treatise on the restoration of the Danube River was withdrawn from distribution, despite the immediate loss of a large sum of money, when it was realized that he was the author of one of the book's chapters!

Viktor understood trees and forests. Their activity is far more vital to us

than we appreciate. Moreover, he said the usual inferences by arborologists concerning tree rings, water and growth rate are invalid. Why they grow at the tips, how they get sap up from the roots to their tops, how they interact, among themselves and with the soil, the different nature of thin-barked and thick-barked trees—he examined all these subjects. Clear-cutting, by the way, the barbaric lumbering practice popular these days among the profit-hungry, is a serious "crime" against the forest, the soil, the fauna, the water and the local temperature: trees perform many essential functions, including to cool the soil and the air, impede erosion, fix carbon dioxide, are essential to the development of mature water, and they protect springs, the natural outlet for mature water.

One natural force Viktor made great use of is implosion, the opposite of explosion. Implosive forces, generated by producing vortices (e.g., swirls visible in water) can exert extraordinary power, as much as 127 times that of a comparable explosion. Implosion involves vacuum (which is a misnomer in his system), another phenomenon studied by Viktor and the basis of several machines he developed. One of these emitted a minute stream of water of such power that it "pierced right through a 4 cm (over 1 1/2") thick concrete slab and a 4 mm (about 1/8") thick super-hardened steel plate with such force..." (pg. 281). Utilizing similar phenomena but with air as the medium, Viktor designed and had constructed two flying saucers. Several were built by other groups after these prototypes. One of these later models was launched in 1945 and, in three minutes, rose to over 58,000 feet, flying at a forward speed of 1320 mph. No electricity was used, except to start its rotation.

Viktor's perceptive eye led him to attribute particular significance to the egg shape. Indeed, that shape could even enable stones, raised off the bottom by vortices in very cold, moving water, to rise to the surface and, for a time, to float. That shape in its many variations is approximated by many fish and enables them to swim effectively against even strong currents. In fact, the fish may be propelled forward by the vortical forces exerted at the rear of its body just in front of the tail.

This shape is impressively strong and Viktor used it in many of his inventions. He designed and had constructed a system for moving large logs from the mountaintop, where they were cut, to the mill, in the valley below and a significant distance away. This system, called a flume, was an egg-shaped trough that curved its way down the



Get the best side of the deal every time with these powerful feng shui secrets.

Negotiate with Feng Shui
1-57618-038-8 • \$12.95

Seven methods of contacting those who can relate the truth of the afterlife.



Contact the Other Side
1-57618-377-8 • \$14.95

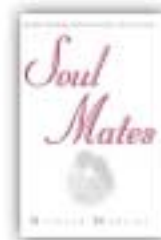

Find the person who has been with you across time and space, and live your destiny together.

Soul Mates
1-57618-789-7 • \$12.95

The best real-life stories of strange events from the pages of FATE magazine.



True Mystic Experiences
1-57618-262-3 • \$9.95

Call 1-877-NEW WRLD or visit www.llewellyn.com to place an order or to get a FREE color catalog. Llewellyn books are also available at fine bookstores everywhere.



INDIA'S GREATEST SPIRITUAL EPIC



"Blockbuster treatment!"
—The Guardian, UK

"I could not tear my mind away!"
—Magical Blend magazine, USA

"A well-crafted saga that will be appreciated by Western readers. Highly recommended!"
—Midwest Book Review, USA

"Its truths are unassailable, its relevance beyond dispute, and its timelessness absolute."
—Atlantis Rising magazine, USA

A masterpiece of adventure, intrigue, romance, and spiritual wisdom, *Mahabharata* is the fascinating story of the five heroic Pandava brothers, who are robbed of their kingdom and exiled. Travel with them on an extraordinary journey, meeting sages, kings, demons, heroines, and celestial beings. Krishna Dharma brings the characters and teachings of this great classic to life with clarity and vibrancy.

Hardbound • 6" x 9"

**960 pages • 16 full-color plates
20 line drawings • \$39.95**

**Special 10% discount for
Atlantis Rising readers!**



**TORCHLIGHT
PUBLISHING**

Call toll free: 1-888-867-2458

Fax: 1-559-337-2354

E-mail: torchlight@spiralkomm.net

Web: www.torchlight.com

CALL FOR FREE CATALOG

BOOKS

valley, carrying logs in water released into the flume from an egg-shaped reservoir. The water was caused to swirl at bends, both keeping the logs flowing in the trough's center and maintaining the water cooler, thus denser, than warm water. Even logs heavier than water could be transported, in which case fresh, cold, dense water was injected into the flume at critical points to keep them off the bottom.

Furthermore, this system (of which 17 were built, mostly in eastern Europe) would not have worked had it not been egg-shaped.

Viktor advocated the use of wood and copper (or copper covered) implements. He devised plows that neither generated undesirable currents in the soil nor facilitated the development of pathogenic bacteria as steel and iron could. In 1958, during an ill-fated trip to America,

from which he returned ready for death, he described the mid-western landscape over which he flew as a "dying land," dry, hot and treeless as it was, irrigated by "firewater" from above-ground water tanks. Viktor felt that human consciousness was adversely affected by "food" grown under non-optimal conditions as these and utilizing artificial fertilizer which destroys the soil.

Another arena where industrial man has shown a pronounced destructive proclivity, and in which Viktor successfully endeavored, is the matter of water supply and drinking water. Viktor stated that the use of cast iron and steel pipes, which had replaced wooden and stone conduits, degraded water quality, contributing to illness, specifically cancer. Flowing through a cylinder destroys the inherent structure of wholesome water, from mechanical processes associated with the chaotic movement of its molecules and the result of friction against the pipe's walls, which is very high.

Over his many years as a penetrating observer of nature, Viktor wrote thousands of pages. It is said that fre-

quently he had no idea of what he had written until he later read it. What appears to have emerged is an entirely unique cosmology and physical chemistry discussed, using concepts that differed from accepted doctrine so markedly that virtually none of the intellectual communities his thought encompassed even acknowledged his writings. Viktor argued that the natural world arose through the interaction of subtle energies deriving from a fourth and fifth dimension. These energies were potentiating, of very high frequency, im-

mensely powerful, not sensed by us and dynamic, in an easily destabilized equilibrium. Many of our scientific "laws" were invalid because we did not take will, spirit and these higher dimensional energies into account. The law of the conservation of energy is incomplete, motion and energy accounted for all that was, but exceeded greatly our three-dimensional models. We don't understand magnetism and elec-



Schaubertger with one of his many inventions.

tricity nor the nature of water, the atmosphere, the sun and temperature—all of which he considered at length.

Mr. Coates' writing is engaging and, considering the sometimes awkward subject matter, clear. Still, one must read carefully to gain some comprehension of Viktor's unique understanding of the origins, interplay and processes of natural energy. As with so many heroic lives, his was beset with burdens. He knew well the inevitable destination to which our incomplete, unnatural science would take us, writing in 1936, "For a person who lives 100 years in the future, the present is no surprise" (pg. 5). He gave modern humanity a valid path to physical salvation and bore the pain of seeing it systematically ignored, even obliterated. One wonders, "Is now too late?"

Viktor's life and work were truly spiritual, a fact some may not understand and others easily overlook. Committed to a higher good, he endured "the slings and arrows of outrageous fortune," never deviating from his goal. This is the essence of a spiritual life. Mother Nature and God received him warmly. ■

The ESSENTIAL ALTERNATIVE SCIENCE BOOKSHELF

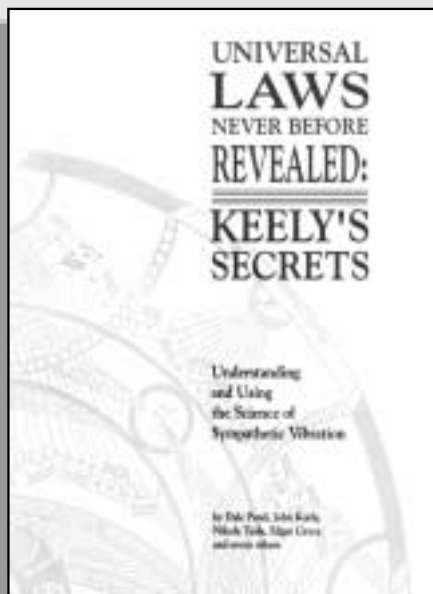

UNIVERSAL LAWS, NEVER BEFORE REVEALED: KEELY'S SECRETS

Understanding and Using the Science of Sympathetic Vibration

Dale Pond, John Keely, Nikola Tesla, Edgar Cayce and others.

One hundred years ago, scientist/inventor/philosopher John Keely built various devices that were able to overcome gravity, tunnel through rock using a hand-held device, use acoustics to power engines, and create superconductivity by using wires made of gold, silver and platinum. Almost lost, this book finally compiles ten years of research by the editor/author that explains the technology used. Understandable to the laymen and useful to the most advanced teacher.

Paperback, 288 pages, 8 1/2 X 11 illustrated

\$19⁹⁵



THE PHYSICS OF LOVE: The Ultimate Universal Laws

Dale Pond, Edgar Cayce, John Keely, Rudolf Steiner, Nikola Tesla

Explore the physics of love and consciousness in an easy-to-understand and exciting manner. The universal laws in this book are applicable to music, electronics, mechanics, healing and all branches of science and philosophy. This science demonstrates the commonality that underlies all phenomena—vibration.

Another name for Sympathetic Vibration is Love.

Science and Spirituality are finally reunited.

152 pages, 9 X 11 Paperback, Illustrated

\$15⁹⁵

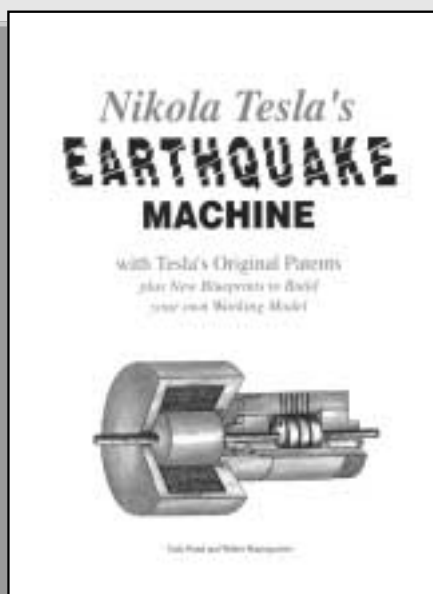
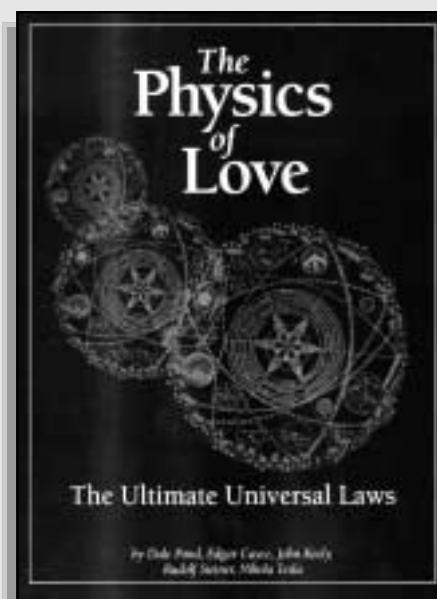

NIKLOLA TESLA'S EARTHQUAKE MACHINE

With Tesla's Original Patents Plus New Blueprints to Build Your Own Working Model

Dale Pond and Walter Baumgartner

In 1935, Nikola Tesla revealed that an earthquake in the region of his New York laboratory in 1898, was the result of a machine he had been experimenting with. This book presents this technology based on sonic vibrations. Now, for the first time, the secrets of the Tesla Oscillator are available to both the layman and advanced researcher.

176 pages, 8 X 11 Paperback, illustrated

\$16⁹⁵

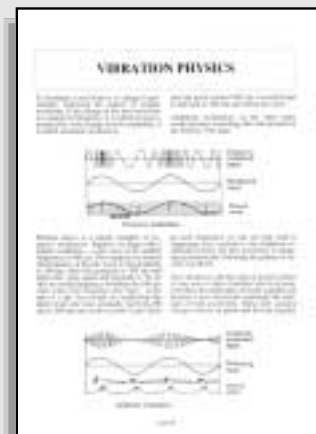

S&H \$4.95 for one book. Add \$2 for each additional

Send Check or M.O. to ATLANTIS RISING • P.O. Box 441 • LIVINGSTON, MT 59047 or call 800-228-8381

Sympathetic Vibrations

Sound Can Do More for Your Body than Entertain It

When you play a single note on a piano, the strings of several other vibrationally related notes will resonate as well, even though you never actually played those notes. Now if you happen to have a guitar near the piano, the guitar string which matches the piano note you just played will start to vibrate as well. Of course, since "you" are sitting at the piano, "you" will actually begin to resonate too. Basically, we live in a sea of matter consisting of rapidly oscillating atomic particles. Everything and everyone is resonating with everything and everyone else. Now take this one step further. Is it so far-fetched to think that if we could somehow determine the vibrational frequencies of, say, vitamins, minerals, amino acids, or even certain emotions or states of consciousness, and then play those frequencies audibly, that perhaps our bodies could begin to resonate with them and come into greater balance? That's exactly what Nicole Lavoie of Sound Wave Energy, a Colorado based company, thinks. Nicole has found that certain wave forms and frequencies can actually help our bodies, mind and emotions to come into greater harmony. Once we're in balance our bodies seem to know exactly what to do on their own.

LIFE ESSENCE SERIES (4 CD set)

In this new four-CD set, Sound Wave Energy has compiled a collection of audio frequencies for turning back the clock. By playing these CDs, which sound like a soft electronic humming, your body can begin to resonate with many of the nutrients essential for maintaining a youthful, healthy condition. Hard to believe? You can find out more at the Sound Wave Energy website: www.cs1swe.com. I also recommend Nicole Lavoie's book, *Return To Harmony* (\$13.99) which gives an impressive account of how these frequencies were developed and some of their amazing results. Although the CDs can be played on any audio equipment (excluding headphones), optimum benefit is derived when played through a subwoofer speaker to take full advantage



of the extremely low frequencies. CD #4, entitled "Deep Sleep," is designed to promote rejuvenating, sound sleep. If your body doesn't need a certain frequency, it simply doesn't absorb it. I have personally used some of the SWE CDs for several years now and am quite impressed with them. If you have any questions or would like to place an order call: Toll Free 1-888-267-2309

LIFE ESSENCE SERIES (4 CD's)
\$149.95

COUSTEAU'S DREAM (a benefit album)

Real Music

A collection of mostly instrumental tracks from other albums, honoring the life and ideals of Captain Jacques-Yves Cousteau, the legendary deep sea explorer and defender of ocean habitats. With artists like Vangelis, Yanni, Kenny G, Michael Hoppe', Tim Wheeler,



Kevin Kern, Kitaro and others...you would think that this should be a reasonably impressive recording, right? Wrong. Although the cause is noble, if you really want to help protect ocean life, you'd be better off just making a donation to the Cousteau Society. With two exceptions (Tim Wheeler & Michael Hoppe'), the musical selections are largely unmemorable, unrelated and just not very good. Although I have great admiration for many of these artists and for REAL MUSIC, I can't really recommend this one.

THE INNER SMILE (Guide Meditations by Liliias Folan)

From the acclaimed PBS Yoga Series, Liliias Folan presents a series of three guided meditations for increasing your sense of inner peace and well being. The title is what caught my eye as I was strolling through Borders recently. What is an "inner" smile? According to the liner notes: "From a place of relaxation, create your own true and genuine INNER SMILE. Soon it will be possible for you to feel your whole body—every organ, bone and cell—smiling back at you. Practice this technique and you will soon be able to radiate the sunlight of your smile throughout your entire body." What a wonderful concept. We tend to go through life, rushing, striving, seldom slowing down enough to remember and be grateful for every individual part of our body that serves us tirelessly. By turning our smile within, our body will actually smile back at us. Makes sense to me. I've been doing it for a few days now and can feel quite a difference. It leaves me with a greater sense of peace and being "comfortable in my own skin." Liliias Folan has been a guest on *Today*, *Good Morning America*, *Donahue* and many others and has several popular yoga videos & books.

To order call: The Relaxation Company, 1-516-621-2727. ■

Rob Resetar composes music for films and television. If you would like to have your CD or video reviewed in Atlantis Rising please send it to: Atlantis Rising, P.O. Box 23528, Minneapolis, MN 55123.

■ BY ROB RESETAR

SAVE MONEY ON NUTRITIONALS, GET THEM IN THE FORM OF SOUND...

Life Essence, created by Nicole Lavoie utilizes Sound Wave Energy technology that instills in sound frequencies specific nutrients for enhancing health and well-being. These CDs act much like a tuning fork, they remind our cells of their ideal vibratory rate, and the re-entrained cells will begin to match the energy of the nutrients. Life Essence is designed to nourish the physical and subtle bodies. Nourishing foods feed the body, and nourishing frequencies feed your subtle bodies. Your subtle bodies actually digest these nourishing frequencies.

AGELESS includes frequencies for HGH, MSM, Paba, B-1, B-12, Glucosamine Sulfate, Chondroitin, Gingko Biloba, Ginseng, Magnesium and Sulfur for longevity and vitality

UP-LIFTING includes frequencies for B-2, B-3, B-6, B-12, Folic Acid, Lithium, Calcium, Potassium and other minerals.

DEEP SLEEP includes frequencies for Melatonin, Biotin, A, B-2, B-3, Calcium, Selenium Glycine, Cystine, Cystiene, Chromium, Zinc, Potassium, Bromine and Methionine.

RENAISSANCE includes frequencies for DHEA, Vitamins A, B-1, B-2, B-3, B-6, B-12, C, and E, Polyphenols, Coenzyme Q10, Calcium, Selenium, Chromium, Zinc, Magnesium, Rubidium, Collagen, Squalene, Beta Carotene, Quercetin, Rutin, Hesperidin, Retin A, Omega 3, Taurine, Lysine, Inositol and additional minerals for enhancing vitality.

Includes 4 CDs and the softcover book *Return to Harmony*, 305 pages.

Life Essence 4-CD Set and Book \$149.95

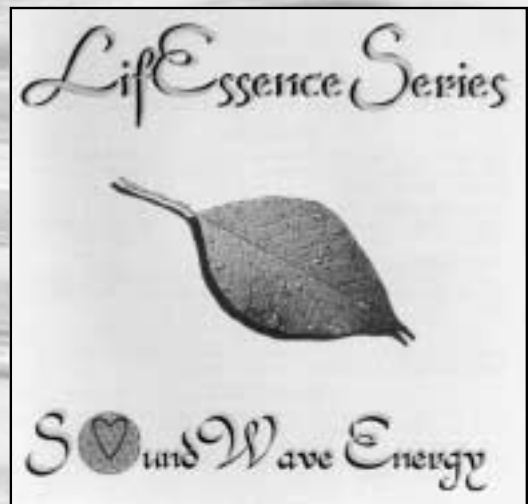

1-888-267-2309

Dr. Joseph Ray

will participate in discussions, lead seminars, speak on the brain, consciousness, its evolution, and the psychological teachings of the ancient Egyptians, G.I. Gurdjieff and Emmanuel Swedenborg for a modest fee.

For information call **207-265-5622**
or write him at RR #1, Box 2469-A
Kingfield, ME 04947

The Edgar Cayce Past Life Astrological Profile

Take what Edgar Cayce calls a "planetary sojourn" into the "afterlife"—a soul journey in the non-physical dimensions between lives—and apply your past interplanetary experiences to your present life!

FIND OUT HOW! Log on to:
www.ElectronicAstrology.com
Norene@ElectronicAstrology.com
Or call 406-333-4261 in Paradise Valley, MT
Secured VISA/MasterCard Transactions

"This Past Life Profile is not only unique, it's utterly fascinating!"
— A Satisfied Customer

for the unusual and enlightening in clothes, music, books, gifts and more



Remember...

Lemuria

(360) 458-2699
Box 7530, Yelm, WA. 98597

HILLY ROSE

Continued from Page 17

the baboon tribe waited at the side of the mountain road for three days. When they saw the car responsible for the death, one of the apes screamed out a signal to attack. After a frenzied bout of stone throwing, they broke out the windshield and put a lot of dents in the body of the car. The driver escaped. Can we escape the possibility that science has only touched the surface of communication and intelligence in the animal kingdom?

Every day science is baffling us with new findings. What is certain in my mind is that homo sapiens (today's men and women) probably have been destroyed many times and come back many times. Quit worrying about global warming. During the past 100 years, global temperatures have only increased 1.1 degrees. Quit worrying about the ozone



hole. It filled itself a bit this year, and probably will continue to do so. The eruption of Popocatepetl did much more damage than all of industry to the ozone hole in the year 2000.

The truth is that science, with all its miraculous tools, hasn't got a clue to when the world as we know it will end. Without doubt, the end is coming — as it always has.

Think of what has happened in the measly 2001 years since Christ. It staggers the imagination to consider the 6000 years since the Sumerians. One has to wonder if, indeed, extraterrestrial rocks were the basis for life on earth. If so, is it such a leap of faith to believe that extraterrestrial intelligence and beings peopled this five-billion-year-old earth (give or take ten years) many times? The adage says history repeats itself. THE END IS COMING! Maybe sooner than you think! ■

Michael Mandeville's massive study of the Prophecies of Edgar Cayce in light of the latest scientific research is NOW AVAILABLE IN TRADE PAPER BOOK FORM.

Return of the Phoenix

A Trilogy of the World Epic

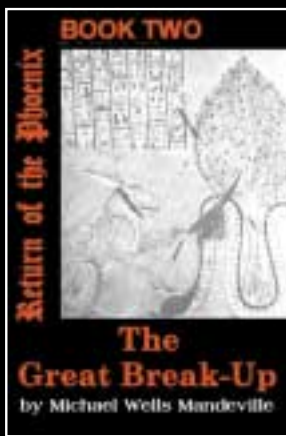
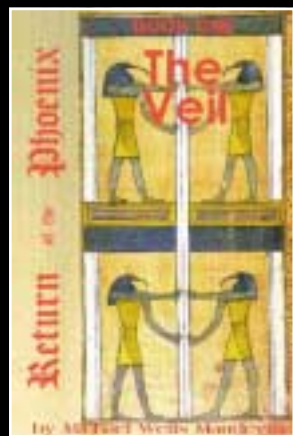

Vol. I **\$28⁹⁵** (+s&h) Vol. II **\$24⁹⁵** (+s&h) Vol. III **\$42⁹⁵** (+s&h)

Complete Trilogy (1540 pages) \$87⁹⁵ (+s&h)

For S&H add \$4.95 for one item and \$2 for each additional

To Order Call **1-800-228-8381**

An anthology in three books of the stories and prophecies of Edgar Cayce, including a scientific assessment of their validity, a summary of Cayce's visionary story of the last 100,000 years of human history, and a complete presentation of his Millennial prophecy, which includes a shift in the location of the poles, catastrophic earth changes, an opening of the Hall of Records in Egypt, and the return of Y'shua to help the survivors recover.

Book One: The Veil

The life, times, ideas, readings, metaphysics, prophecies, & capabilities of Edgar Cayce—a complete overview of his work and an analytic summary of the major assessments of his psychic talent.

Book Two: The Great Break-Up

A comprehensive anthology and verification of Edgar Cayce's psychic predictions and clairvoyant vision about business, economics, history, international affairs, politics, and other topics. Cayce's predictions are related within the times of their making during 1923-44 and presented with the story of their scientific assessment during the 90s along with the results which systematically document an objective score of 92% for Cayce's general predictions.

Book Three: The Prophecies

A definitive anthology and scientific analysis of Edgar Cayce's millennial prophecies about the opening of an ancient time vault in Egypt and a shift in the location of the poles which will create many catastrophic changes in the earth. The verification of Cayce's predictions and stories is presented along with a discussion of major new scientific discoveries about the mechanism of plate tectonics and geological change and a comparative review of corresponding parallels in the ancient records and prophecies of various religions and tribes.

KURSK

Continued from Page 23

that a tapping sound was being heard from the silent hulk resting on the muck and rock sea floor at the bottom of Barents Sea. The world was told that a nuclear submarine may have gone down in that area.

Far away from the war games, in America, a group of remote viewers, the St. Louis based U. S. Psi Squad, heard of the tapping sound reports, and began an operational remote view to determine if anyone indeed remained alive on the stricken submarine. The group's focus is to help whenever or wherever their unusual skills may be of help. (For more on remote viewing, see Jeane Manning's interview with Russell Targ in this issue)



A mini-sub is hoisted above the Kursk (Russian TV)

In the late hours of August 14 and ending on the 15th, the group's leader began a search for the doomed nuclear submarine and quickly determined that the explosion had not involved the Kursk's nuclear reactors, and that not only were sailors still alive, but that there seemed to have been many more persons aboard than had been reported. Some of them had not been sailors.

Obvious signs of a blast near Kursk's prow on the right side were evident, and indicated that the explosion had blown the metal fabric outward, indicating an accident from inside the boat. Living men were seen, some strapped in, in horrific conditions of cold and almost complete darkness. A few sparks of green light were seen, perhaps emergency lights, and small devices which may have been heaters were observed. From inside, it was evident that both inner and outer hulls had been breached. Twisted and buckled railings and metal were seen everywhere in the forward area. Some seawater was seen even in those few rear compartments where hatches had been closed by the survivors, even though it appeared that these hatches had not completely closed. Most important, it was evident that Kursk's nuclear reactor compartments had not been breached.

Early on August 16, it was decided to contact other members of the remote view team via e-mail and to ask them to concentrate on Kursk's per-

sonnel, to be certain that there were indeed men left to be rescued. An e-mail of the original remote view was sent to the group's Webmaster in a southern State.

First to respond was a Canadian, new to the team, but very accurate. By the afternoon of the 16th he had reported seeing the vessel on the bottom and that the men in his area of sight were all dead. Changing his perspective to another area, he observed a crew member who seemed to be drowning at that moment. He also saw the greenish color and pegged it as 'goo' overlaying the seawater. His report included the words 'turbines, locks, mechanisms, mechanical failure, containment, breach, pressure.' An exterior view of Kursk showed a hole or rupture in the hull, which was due to an explosion from inside.

Second to report was a member who is a police officer, with the group for nine years. His response re-

ported damage on the right side of Kursk, extensive damage including a large hole in the hull. He saw living men, some wearing non-military clothing, in a state of shocked disorganization. The name 'Kenzy' was apparent. Flooding was widespread and remaining air was 'going bad'. He felt none of those living would get out alive.

Six confirmations caused the group leader to urgently attempt to pass this information on to higher sources. However, Russia's top authorities were refusing outside help, apparently because at this point they believed Kursk had been sunk following a collision, not an internal explosion, or so it is thought.

Main points in continued remote viewing showed that although a good sized group of men survived the initial accident, their numbers were decreasing every few hours. A final remote view on Aug. 20th revealed that all were now dead and the Kursk completely flooded. At that point, the group concluded that they could be of no further help and stopped the hopefully lifesaving efforts.

Remote Viewing is not a new skill. It was brought to operational and tactical targets during research at SRI (Stanford Research Institute) and culminated in the U.S. Army's Stargate Pro-

I AM AMERICA MAPS

as seen on the NBC Special "ANCIENT PROPHECIES II"



I AM AMERICA Full Color 24" x 28" S & H Included

\$21⁰⁰

You heard Lori Toyte tell how she—under the guidance of the ascended master Saint

Germain—created prophetic maps of America and the world. NOW YOU CAN TAKE A CLOSER LOOK.

S & H Included **\$33⁰⁰** FREEDOM STAR Full Color 36" x 52"



Order NOW!



1-800-228-8381

KURSK

ject at Ft. Meade, Md. The Kursk viewing group is the only non-military RV team in the U.S.

Group members feel the Kursk incident clearly shows the immense potential and value of teams trained to perform such operational remote views in exactly this type of life and death scenario. In a vessel on the bottom of the sea, or a vehicle on land or in space, data can be accessed by trained viewers providing valid information and details when more conventional means of contact such as radio or computer are damaged, destroyed or inactive. Lives might thus be saved that would otherwise be lost, and timely information be gained.

It is important to state that only one member of this RV team had any experience with naval vessels of any type and that this member was not able to provide help as he was still in training. His service as Webmaster, however, helped to coordinate these sequences.

Conclusions

It seems logical that some means of entering the uptilted rear sections of Kursk might have resulted in saving those yet alive, had the data reached the proper sources.

Additional RV data included that, while otherwise unknown at that time:

- men were still alive on Aug. 14-17/breathable air remained, aft
- the explosion was inside Kursk
- almost all officers were killed
- the rear hatches were not jammed
- the nuclear reactors 'scrammed' to inactivity promptly
- there had been two explosions, one smaller, the second estimated at from 3.5 to 3.8 on the Richter scale
- a torpedo had gone rogue and exploded others nearby
- the inside watertight hatches had

POURED STONES

Continued from Page 25

to disappointment, and has now settled nicely into a peaceful resignation to a situation that is, let's face it, somewhat amusing.

Those who have read my book will know that I did not proclaim it to be the ultimate truth, or final word on a subject that is not only complicated, but which evokes such high passion. I offered my work as an alternate view with the caution that there was much more work to be done and what I had proposed was open to debate and ultimately might change. I was excited to share my discoveries with the world.



Russian Oscar-class submarine like the Kursk (U.S. Navy).

jammed partially

i. divers would reach the ship in time to have saved lives

g. all men were dead by Aug. 19
(Dated e-mails containing these data are now being validated)

The group has received unofficial 'thanks' from Russian citizens who became aware of their efforts.

A Note from the Dead

On Oct. 26, CNN released the news that a letter was found on a body recovered from Kursk. Lt D.R. Kolesnikov reported the desperate efforts he, a junior Officer, had made in sending 23 living seamen to the farthest rear compartments of the doomed submarine. Kolesnikov (Kenzy?) said they'd tried to use the escape mechanisms but had failed to escape. Knowing they were doomed, he had penned a note to those who would find his body and another to his young wife.

There may be more such notes

found which may help to add details to this most unfortunate chapter in the annals of the 'silent service'.

Note: At least four submarines, two or more of them nuclear powered, lie in deep waters around the globe.

Seawater, as is well known, is corrosive. ■

The Author wishes to thank O.H. Jones, CNN, Reuters, Associated Press and many other news groups including The Palmer Press website for background on Kursk.

Beverly C. Jaegers is a known field researcher in Psi and Remote Viewing, author of The Psychic Paradigm (Berkley Putnam 1998) and formed in 1971 the U. S. Psi Squad, a group of trained remote viewers, working with law enforcement and scientists. Many of her works are available at Amazon.com and the website is to be found at www.uspsisquad.com

They are, I believe, the discoveries of the century, but I refuse to engage in discourse that resorts to hostility and unprofessionalism. It just ain't cricket!

Seeking advice on how to respond to Morris's criticism, I was told to ignore it, and so I will. Instead I will focus on the fundamental differences between Davidovits/Morris's theory and my own. Rather than defending my conclusions, about which Ms. Morris seems so angry, I will go deeper. I will objectively address the questions that many of my readers and I have about the poured stone theory, and dig deeper in gaining an understanding of technical details that may have previously escaped us. My re-

sponse to Ms. Morris, therefore, is to say that she will gain more support and credibility from a large body of educated, experienced and technically savvy readers if she is able to answer, in detail, a few technical questions about the artifacts she claims were poured like concrete. Based on the hard evidence that others and I have discovered in Egypt, it is imperative that any explanation of how these objects came into existence satisfies these technical questions. The same questions can be modified and applied to other theorizers of how the ancient Egyptian's created their granite artifacts, and, for the sake of this article, I will call them: Dunn's Litmus Test

Ms. Morris, you have done an excellent job of explaining how Egyptologists' theories for creating ancient Egyptian stonework simply will not work. This becomes obvious with every attempt they make, and I applaud your effort for this. You then claimed that high early-strength rock-concrete, or geopolymerized rock, can be shaped to perfection with primitive tools while still in the soft stage of setting. In The Giza Power Plant, I describe several ancient artifacts made of igneous rock that include dimensions and tolerances. I have included a picture of one of them as an example. Please explain, in technical terms that an engineer and machinist like myself can understand, how you would create this artifact. For instance:

What do you mean by perfection? In engineering, perfection is an absolute that is never accomplished. We deal with tolerances, or the amount of deviation that is "tolerated" from a theoretical perfect condition. In shaping materials, the tolerance is applied to the geometry and dimensions of the artifact.

What primitive tools will you use to shape your geopolymer to perfection? The answer to this question depends on how you answer the first question.

What primitive tools will you use to ensure that the perfect shape you create is indeed perfect? Again, the answer to this question depends on the answer to the first. Please remember that your audience consists of people who have hands-on experience at shaping materials, so if you do not have such experience yourself, you may want to consult with someone who does.

Regarding pouring a geopolymer that resembles an igneous rock, such as the example we are discussing which is granite, the mix would need a high percentage of silicon quartz crystal. In the case of the granite at Giza, it has been identified as being quarried at the Aswan quarries, 500 miles down the Nile River, and has about 55 percent quartz crystal. The agglomeration of granite requires that solid quartz chips be added to the mixture, similar to concrete that contains stones or gravel. Your theory states that the stone was shaped to perfection with primitive tools while the geopolymer was in the soft setting stage. If this is the case, and assuming that you have been able to satisfactorily answer the queries above, my questions continue as follows:

- How close to net shape will the geopolymer be molded?
- From what material will you make the mold?
- How will you manufacture the mold?

- How much shrinkage will occur in the material?

- Will the geopolymer cure in the mold, or will it be taken out of the mold and allowed to air cure?

- If it is taken out of the mold to cure, how much plastic flow will occur in the material before it is shaped to perfection?

- How much time will you have to work the stone to its desired perfection before it sets and becomes hard?

- How much plastic flow will occur after it is no longer workable with your primitive tools?

- As you are probably well aware,



Quarry marks at Aswan



Drill hole at Aswan



Precision curve in ancient artifact at Giza

concrete will begin to set as soon as it is mixed. For the object in question, which weighs around 6 tons, how many batches will you mix?

When pouring concrete in a mold, the hard stones are held back from the surface of the mold and if the mix is vibrated sufficiently, the cement will flow around the stones, thereby presenting a smooth surface when the mold is opened. When viewing an object such as this, if a stone is visible, it is merely the tip.

Why, then, do we find on the granite artifacts in Egypt, finished surfaces that display the same percentage of quartz as those surfaces that are exposed after the rock has been split

apart? On these finished surfaces, the surfaces of the quartz crystals do not deviate from the surfaces of the feldspar. Is it not, therefore, logical to assume that the object was finished after it was removed from the mold? Assuming this to be correct, I will ask the following:

- Because you are using primitive tools to shape the synthetic granite to its final perfect shape, and your entire premise is based on the impossibility of using primitive tools to cut hard igneous rock, what happens when your primitive tool encounters the quartz in the granite?

Does the quartz somehow miraculously become softer during the setting stage? In pouring concrete, the gravel stones retain their original hardness and whether cutting the concrete while it is setting or after it is set, the tool necessary to cut it would need to be able to cut through these hard stones.

Other artifacts I discuss in my book are the granite and basalt boxes in the rock tunnels at the Serapeum near Saqqara. One of the arguments you use to support your theory is that the ancient Egyptians poured their stone in situ because it would be impossible to move such heavy objects. These boxes weigh in at around 70 tons without their lids and, as I describe in my book, have precisely machined surfaces, both inside and out. Within the hypothesis posited by you and Davidovits, please answer the following:

- If these huge boxes were poured in situ, why is there an unfinished box located in one of the passageways and not positioned in a crypt like all the others?

- An unfinished lid, weighing an estimated 20 tons, is also located away from the box and, presumably, would eventually need to be lifted on top of the box and the entire assembly moved into position. How does your hypothesis explain this?

- These boxes, finished to a remarkable .0002 inch (to the extent that I was able to measure them) both on the outside and the inside, have flat surfaces, whereas the unfinished box is extremely rough. A great deal of material would need to be removed to achieve the tolerances found on the other boxes. If they were poured, would it not make sense to create a mold that had flat surfaces and would cast the object to as close a shape as possible?

The questions I posed on the previous artifact, regarding finishing your geopolymer to perfection with primitive tools, also apply to this artifact, so I will not repeat them here. Before we leave the Serapeum, though, let me inquire: →

POURED STONES

• You support the conventional theory about the age of the site and that the boxes in the Serapeum were used as sarcophagi for the internment of the Apis Bull—a sacred animal in ancient Egypt. This hypothesis has been proposed because of a few bones that were found inside the boxes. My question to you is, therefore, in the development of this hypothesis, at what stage do you and orthodox Egyptologists introduce the bull?

Ms. Morris, you wrote in your review of my book that I have machined my "poor historical research and observations as a machinist into an untenable theory that sinks to the level of other similarly poorly researched popular books." [Where it will] "ultimately and appropriately be swept into the dust heap of history." My historical research, as it pertained to the orthodox view of pre-history, was not poor, but sufficient to know that, based on a lifetime of experience and technical research, history

needs to be rewritten. I did not claim any expertise or authority as an Egyptologist or archaeologist. I was presenting a point of view that I believed would be welcome in a field of study

logists and archaeologists. You indicated that I could have saved myself such embarrassment if I had only reported what I had discovered in my research in Egypt, instead of offering a

technical solution to these anomalies. I have been blissfully unaware of any scorn being heaped upon me, and in fact, have been reveling in a groundswell of support from technical people all over the world, including engineers, geologists and physicists, who I consider my peers. Who are these scornful people to whom you refer? By any chance, might they be supporters of your pour theory? Do they share the same level of academic integrity that you have exhibited in your personal attack on me through Amazon and your website? Whoever they may be, perhaps they can assist you in answering the questions I have posed. There will be many readers

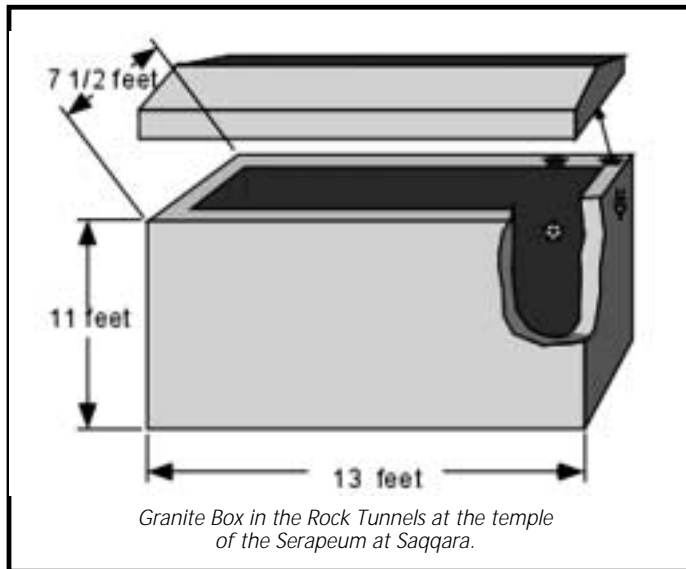

Granite Box in the Rock Tunnels at the temple of the Serapeum at Saqqara.

that heretofore had revealed no technically correct answers.

You also claimed on your website that I have attracted the scorn of Egyptologists and archaeologists.

awaiting your answers.

But no hurry. I am patient, so take your time. ■

Rejuvenate yourself.



introducing the **Far-Infrared Dry Sauna**. This space-age wellness technology, developed by **NASA**, is now available in a portable dry sauna. Healing Far-Infrared Light is directly absorbed into the body and is clinically proven to relieve muscle and joint pain; boost the immune system; clear cellulite and deep cleanse the skin; remove cholesterol and other toxins; and increase heart rate to the equivalent of burning 700 calories or running 6 miles in just 1/2 hour! Sets up in minutes. Own your own for as little as \$2 a day! To receive your free brochure and clinical research report, call toll free:

877.292.0020

EXPERIENCE NEW BEING SEMINARS

BEING N seminars

Join us starting Summer 2001
in Northern California for Adventures
on the Frontiers of Knowledge

REMOTE VIEWING, OVER-UNITY ENERGY DEVICES, ENTHEOGENS AND PSYCHEDELICS, EEG NEUROFEEDBACK, SPIRITUAL EMERGENCY, ANOMALOUS TRAUMA, CHANNELING, CONSCIOUSNESS RESEARCH, THE UFO, POLITICS BEYOND LEFT VS. RIGHT, HYPERSPACE, POLYAMORY, BIODYNAMICS, RADIONICS, PARAPSYCHOLOGY STUDIES, REICHIAN ORGONOMY, SPIRIT RELEASEMENT THERAPIES

Opening Workshops Summer- 2001
Visit <http://newbeing.bizland.com>
Presenter's Proposals Invited.

Continued from Page 31

lecular structure of the abducted person, which is probably experienced as being in another dimension. This explains how they are able to move them through solid windows and walls. Karin says, "It's racking just to go through the window because they have to alter your vibration in order to get a solid object to pass through another solid object, literally. And that happens."

None of this is very surprising to anyone familiar with UFO lore. For decades there have been reports of UFOs winking in and out of physicality. There is very little doubt now that the aliens have the ability to freely shuttle in and out of the etheric realm where space/time is collapsed, and this probably explains how they are able to travel such vast distances in short periods of time. While this concept may seem strange to scientists, it's a cardinal precept to anyone into metaphysics, and explains many otherwise inexplicable phenomena such as telepathy, remote viewing, astral travel, and astrology. But it is this interdimensional component of the abduction phenomena that keeps scientists at arm's length. And yet, the most recent trends in theoretical physics are coming to that very place, especially quantum physics. Dr. Mack quotes theoretical physicist Michio Kaku who summed it up exquisitely in 1998, "There's not enough room in the three dimensions that we're familiar with to accommodate all of the forces of nature."

An Environmental Apocalypse

For just about everyone who believes in the UFO/abduction phenomena, the most important question is, "Why are they here?" There is endless speculation about their intentions and the so-called "alien agenda." In *Passport*, Dr. Mack, after ten years of intensive research, has come to some categorical conclusions. He believes that the primary goal of the extraterrestrials is to save the planet from toxic doom. As a means to this end, they have undertaken the rapid transformation of humanity through an accelerated global expansion of consciousness, person by person. This, they evidently expect, will engender new attitudes towards cleaning up the environment, and will ultimately bring

about the necessary legislation.

Precisely how Mack arrived at such visionary conclusions from countless recitals of painful probings on spaceship operating tables is not entirely obvious at first glance, but comes more into focus as we consider the personal testimonies and transformations of the abductees that he has worked with, along with interviews with Shamans from more primitive cultures. What is somewhat mystifying about this conclusion is the fact that, as Mack says himself, "Generally speaking, experi-

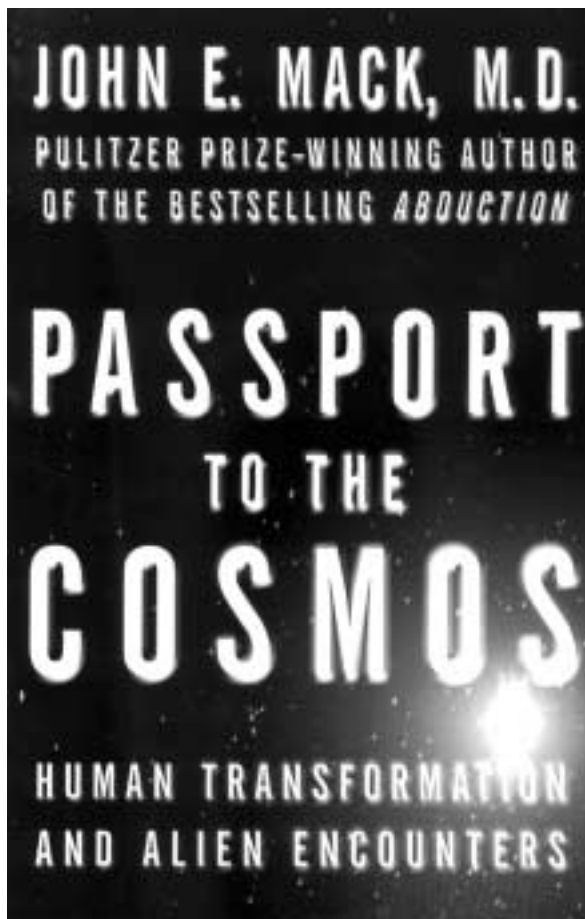

encers do not appear, on the basis of their backgrounds, to be particularly likely candidates for becoming environmentalists." However, the E.T.s may be counting on getting the message across through sheer numbers. According to a 1992 Roper poll, approximately 4 million adult Americans had been abducted. Extrapolating worldwide, the global number would have been around 96 million in 1992! Also, it is very likely that the aliens anticipated that these stories would get wide distribution in print, as they have indeed through Mack's books.

The narratives of the cases Dr. Mack reports on in *Passport* are filled with dire warnings and prophecies about

the fate of the planet. Jim Sparks, one of Mack's subjects who claims he has been educated extensively on board the spaceships, says he has been shown "scene after scene showing mankind's destructive ways and its impact on the environment." Along with the visuals he also gets an accompanying telepathic message: "YOU ARE KILLING YOUR PLANET. YOUR PLANET IS DYING."

Sparks attends "meetings" on the spaceships where he is told, "Your air, your water is contaminated. Your forests, jungles, trees and plant life are dying...You have an overwhelming amount of nuclear and biological...contamination. Your planet is overpopulated."

The aliens then told him that they had made agreements with world leaders to correct these conditions, but they had all been broken because "those in power" view such measures as "a military and security threat," which is why they were now turning to "average" persons.

Abductees are frequently shown visions of apocalyptic destruction where "the sky will become dirty, the animals will vanish, the seas will turn into poisonous mud, water will be even more precious than gold..." They speak of tidal waves, earthquakes, volcanic eruptions, weather changes, worldwide sickness, clouds of static electricity, a pole shift, meteor showers, cities gone, rubble everywhere, and "God's wrath exploding." The abductees are given to understand that this will be a "cleansing." Although it is unclear to them whether they are seeing actual future scenes or possible scenarios, the emotional impact is usually severe.

According to at least two of Dr. Mack's cases, the aliens confessed that they had destroyed the environment on their own planet through similar disregard, and had to move underground where they deteriorated physically, having previously resembled earthlings. According to Jim Sparks, the alien motives are less than altruistic and noble. He claims that they are harvesting earth products for profits in other parts of the galaxy, and are simply trying to protect their investment! Credo Mutwa, a South African Shaman, agrees. He says, "they don't love us. They need us...how will they get things from us if our bodies are dirtied with drugs and toxins from the air?" This brings us to the most incredible part of the story, and the most damaging to the alien claims of selfless service to mankind. →

JOHN MACK

Continued from Page 63

The Hybrid Project

Dr. Mack devotes an entire chapter to the alien program of hybrid development. It is now well established that for decades they have been impregnating earth women with alien seminal seed, and in many cases collecting human male sperm and using it to impregnate alien females. In a typical case, they remove the human egg, add the alien component, and then re-implant the fertilized egg in the womb. They then let the pregnancy advance for three months, at which time they return to remove the fetus and transport it to their laboratories where it is immersed in a fluid-filled incubator.

In most cases, the mother never realizes that she was ever pregnant at all, and if she does she believes that she has had a spontaneous miscarriage. In many cases, the women are fully aware of the process, and are taken on tours of the spaceships. They describe long rows of incubators containing fetuses at various stages of development.

Mack's patient Isabel says that she experiences "a mild pregnancy" during which she doesn't get so sick and the menstrual cycle is almost nonexistent. She says she usually feels a tickling sensation in her womb much earlier than with a normal pregnancy. At five weeks, it is comparable to five months normally. Those who have seen the hybrids say that typically they are sickly looking with wispy hair, mottled complexions, scaly and flaky skin, and usually have large heads with big eyes. Lately however, since 1997, Dr. Mack began to hear of more successful creations.

His patient Andrea says she has seen her seven-year-old hybrid son Kiran, and that he is fully integrated, i.e., "fully human and fully alien" and is healthy. Another patient, Karin, says they have been trying to "acquire ...viable bodies and emotionality by integrating with us." Dr. Mack says that many of the women have observed that there seems to be a dimensional alteration about the whole process, i.e., two different vibratory levels or dimensions being brought together. Karin says that "in order for the hybrid project to succeed, our dimension will have to be penetrated by theirs." Several of the women believe that, on some level, they have chosen to participate in the Hybrid Project, and that it is an important work.

No Pain, No Gain

In the chapter titled "Trauma and Transformation," Mack takes the posi-

tion that although the abductees may be terror-stricken and traumatized initially, as they usually are, if they refuse to be victimized, confront the fear squarely, and take advantage of the opportunity for growth, ultimately their consciousness expands, and they become transformed. Does this mean that such transformation is the intended result of the experiences, and that the aliens are using some sort of shock treatment to force us to grow up and save the planet? Isabel asks, "How do we know that (they)...aren't using extreme emotions to help us grow?" However, the evidence in *Passport* strongly suggests that such transformation is a by-product of the experience—the result of a courageous reaction, and the triumph of the human spirit over life-shattering and psyche-shattering events.

The abductees testify that exposure to the "fourth dimension," where the aliens basically reside is, by itself, life transforming, and demolishes previous illusions of our cocoon-like material existence. They also say that comprehension of the immensity of a creation that includes such strange creatures with such marvelous powers is a powerful mind-opening and religion-confounding realization. Ultimately, the abductee becomes acutely aware of his or her own inner power. Karin sums it up nicely when she observes that the collapse of the barriers between dimensions allows one to become "very aware of your soul. You're very aware of your higher consciousness, that thing inside of you that's you."

This means that individual growth is simply an unavoidable, unintended result of what the aliens are doing. It is beginning to appear that probably the Hybrid Project is really what this is all about, and that perhaps Jim Sparks is right—they are trying to save the planet for themselves. Dr. Mack suggests, however, that, whatever their intent, this gives us the opportunity to seize on these events to our own advantage. He says, "...the alien abduction phenomenon is largely an opportunity or gift, a kind of catalyst for the evolution of consciousness in the direction of an emerging sense of responsibility for our own and the planet's future."

For those who believe that such jump-starting of consciousness expansion is a violation of natural progression, and would therefore resist this invitation, we might point out that military reprisal does not appear to be an option at this point. However, worldwide acceptance of this reality might be the first step towards a solution, and both of Dr. Mack's books will definitely help us reach that goal. ■

OLMECS

Continued from Page 32



The author with Giant Olmec heads. Note the clearly negroid features.

back to at least 3000 B.C. — a date twice as old as that conceded by established archaeologists.

The Mysterious "Day One"

By the time I was writing *The Lost Realms*, the book devoted to the prehistory of the Americas, I was sure that the arrival of the Olmecs with Thoth/Quetzalcoatl could be established with astounding precision. The key to unlocking the enigma was the Olmec Calendar.

In addition to the Haab and the Tzolkin, there was in Mesoamerica a third calendar, used to inscribe dates on monuments. Given the name the Long Count, it was not cyclical as the other two, but linear—a continuous one, counting the total number of days that had passed since the counting began on a mysterious Day One.

By means of glyphs denoting groups of days (1, 20, 360, 7,200 or even 144,000) and dots and bars giving the number for each group-glyph, monuments were dated by saying: A total of so many days from Day One have passed when this Monument was erected.

But what was that Day One, when did it occur, and what was its significance?

It has been established beyond doubt that this Long Count calendar was the original Olmec calendar; and it is now generally agreed that Day One was equivalent to August 13, 3113 B.C.

But what does that date signify? As far as I know, the only plausible answer was provided by me: It was the date of Thoth/Quetzalcoatl's arrival, with his followers in Mesoamerica!

The Unexpected Corroboration

All official publications continue, however, to remain at 1250 B.C.—1500

B.C. at most—as the date of the start of the Olmec presence.

Imagine my pleasant surprise to come across an eye-witness report by the astronaut Gordon Cooper in chapter 11 of his book *A Leap of Faith*. "During my final years with NASA," he writes, "I became involved in a different kind of adventure: undersea treasure hunting in Mexico." One day, accompanied by a National Geographic photographer, they landed in a small plane on an island in the Gulf of Mexico; local residents pointed out to them pyramid-shaped mounds, where they found ruins, artifacts and bones. On examination back in Texas, the artifacts were determined to be 5,000 years old!

"When we learned of the age of the artifacts," Cooper writes, "we realized that what we'd found had nothing to do with seventeenth-century Spain... I contacted the Mexican government and was put in touch with the head of the national archaeology department, Pablo Bush Romero."

Together with Mexican archaeologists the two went back to the site. After some excavating, Cooper writes,

"The age of the ruins was confirmed: 3000 B.C. Compared with other advanced civilizations, relatively little was known about this one—called the Olmec."

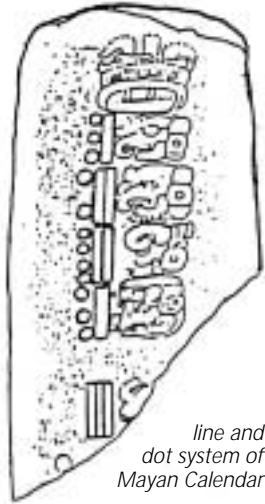

line and dot system of Mayan Calendar

Proceeding to describe some of the amazing discoveries about the Olmecs and their achievements, Gordon Cooper continues thus:

"Engineers, farmers, artisans, and traders, the Olmecs had a remarkable civilization. But it is still not known where they originated... Among the findings that intrigued me most: celestial navigation symbols and formulas that, when translated, turned out to be mathematical

formulas used to this day for navigation, and accurate drawings of constellations, some of which would not be officially 'discovered' until the age of modern telescopes."

It was this, rather than his experiences as an astronaut, that triggered Gordon Cooper's "Leap of faith": "This left me wondering: Why have celestial navigation signs if they weren't navigating celestially?" And he asks: If 'someone' had helped the Olmecs with this knowledge, from whom did they get it?

My readers, of course, know the answers.

Has the Cover-up Ended?

The outstanding museum on the Olmec civilization in Jalapa, in the Veracruz province of Mexico, included when it was built a wall panel showing the extent and dates of Mexico's various cultures. On my first visit there, I could hardly believe my eyes: The first (earliest) civilization, that of the Olmecs, was shown as begun circa 3000 B.C.!

I urged the members of my group to take pictures of me pointing to the date: Finally, the date claimed by me has been officially accepted!

On a second visit, however (to which the previous article, *The Case of the Missing Elephant* relates), not only the telltale elephant-toy disappeared; the Olmec column starting at 3000 B.C. was also gone... And the official Museum Catalog, reviewing the Olmec civilization, reverted to 1500 B.C.

But now comes the astronaut Gordon Cooper, who innocently tells, as an eye-witness, what he was told by the chief Mexican archaeologist: 3000 B.C.

And thus, when all is said and done, I stand vindicated. ■

© Z. Sitchin 2000. Reproduced by permission. Sitchin is the author of the best-selling series the *Earth Chronicles* advancing the thesis of extraterrestrial intervention in the history of civilization on Earth.

TIME MACHINE

Continued from Page 36

But few scientists, including Deutsch and Lockwood, have any trouble with the relative absence in our time of oglers from the future, and even Stephen Hawking has recanted, suggesting now that time travel may be possible. "I can think of half-a-dozen ways in which we could not be awash in time travelers, and still time travel is possible," said now-deceased Carl Sagan on a NOVA TV documentary on time travel in 1994. Sagan said it might be possible to build a time machine that can go into the future, but not into the past—but we don't know about this because we haven't yet invented that time machine.

Sagan also speculated that time travel into the past might be possible, but that the time travelers haven't gotten to our time yet since they're very far in the future, and the farther back in time you go, the more expensive it is. The Cornell University author/scientist wondered if perhaps backward time travel were possible, but only up to the moment when time travel was invented. "We haven't in-

vented it yet, so they can't come to us," he explained. "They can come to as far back as whatever it would be, say A.D. 2300, but not further back in time."

Sagan put forth the possibility that the time travelers are here but we can't see them, perhaps because they've perfected something like an invisibility cloak. "If they have such highly developed technology, then, why not?" he said. The author/astronomer speculated that the time travelers are here, and we see them, but "we call them something else—UFOs or ghosts or hobgoblins or fairies or something like that."

Sagan said that, finally, "there's the possibility that time travel is perfectly possible, but it requires a great advance in our technology, and human civilization will destroy itself before time travelers invent it. I'm sure there are other possibilities as well," Sagan concluded, "but if you just think of that range of possibilities, I don't think the fact that we're not obviously being visited by time travelers shows that time travel is impossible."

Many other scientists agree with Carl Sagan. In a recent book, *Beyond Eternity* (Jenseites der Ewigkeit,

Langen-Müller, 2000), noted German time travel authority/author Ernst Meckelburg cites the theoretical proof for the possibility of time travel put forward as far back as 1988 by MIT astrophysicists Michael Morris, Kip Thorne and Ulvi Yurtsever in a paper published in *Physical Review Letters*. In earlier works, such as *Zeittunnel (Time Tunnel)*, Langen-Müller, 1997) and *Zeitschock (Time Shock)*, Langen-Müller, 1995), the Hanau-based author has cited the far-reaching speculations of eminent scientists, such as Israeli physicist Yakir Aharonov and Princeton cosmologist Richard Gott, which have helped place the study of time travel on a respectable footing.

Meckelburg, who received the Swiss Dr. A. Hedri Award for epipsychology (study of post-death mental states) in 1997, the same year Drs. John Mack and David Jacobs received it for exopsychology (study of the ET mind), believes, along with the scientists he cites at length, that time travel must be a fairly commonplace occurrence in the universe. The German researcher asserts that only the mastery of such a technique can account for the many flying objects we apparently see→

TIME MACHINE

coming at us from outer space and frequenting our atmosphere. Since, according to relativity theory, it's impossible to travel faster than light, then "interstellar travel to earth can only come, theoretically, from a handful of nearby star-systems," he says. Yet the thousands of varied sightings in our time and earlier seem to suggest far vaster activity than that. Meckelburg concludes that many ET races must have solved the problem of crossing interstellar distances by achieving the total nullification of time (or, more accurately, spacetime)—by traveling, that is, "via a higher-dimensional hyperspace, in which time is only a sub-dimension—a 'space' without any time at all." Time travel, then, has been achieved by many alien species—and can be achieved by our own.

Ernst Meckelburg's works, along with those of many other researchers into time travel, chronicle many instances where, if not an actual physical device, then some form of mental or "astral" time travel may have been involved. Meckelburg has written at length in *Time Tunnel* on the astonishing "Doddleston" incident in which, in the tiny village of Doddleston, England, in 1984-1986, an entity claiming to be from the year 1545 of Henry VIII's reign seems to have dreamed his way up into our present era. The entity, calling itself Thomas Harden, left 250 messages in flawless pre-

Shakespearean English on the computer screens of researchers, in particular Ken Webster and Debbie Oaks. When "Harden" finally departed, his place was taken by an even more mysterious group of entities, calling themselves the "2109" and claiming to be from that year. For almost a century now, writers on paranormal phenomena have told the story of two English schoolmistresses who believed they traveled back in time and witnessed Marie Antoinette somberly facing her future in the tumultuous days of 1789 that saw the start of the French Revolution.

The visitation took place while Anne Moberly and Eleanor Jourdain were exploring the gardens of the Petit Trianon, at Versailles, in August, 1901;

the two were to describe it in 1911 in their bestselling *An Adventure* (Ernst Meckelburg has reported that Anne Moberly recanted the story on her deathbed, declaring it to be an invention). In *An Experiment in Time* (1927), J.W. Dunne told of how, systematically dreaming his way weeks and months into the future, he may have witnessed a day in advance the devastating eruption of Mont Pelée on Martinique in 1902 (Dunne foresaw the number of dead as 4,000; it turned out

to the year 3500, and its many time travelers.

It's in regard to the cases where actual physical time machines may be involved that there may be another reason why time travel from the future, or elsewhere, may be happening, and we don't know about it. According to journalist Miguel Jones, translator of Peter Krassa's *Father Ernetti's Chronovisor: The Creation and Disappearance of the World's First Time Machine* (New Paradigm Books, 2000), its

presence might be suppressed by one or another government in the same way as, according to Philip Corso in *The Day After Roswell*, the U.S. government suppressed news of the retrieval and back-engineering of UFOs downed in New Mexico in 1947, even while clandestinely introducing alien technology (such as lasers) into our society.

The Flagstaff, AZ-based Jones said that Father Ernetti repeatedly reaffirmed that "anyone building a time machine would have to keep it a complete secret. If word got out, the government, or evil people, would steal or appropriate the machine." The ability to time travel confers enormous power, remarks Jones. "You could murder someone and change the present in a way that suited you. You could travel into the future and bring back knowledge which would enable you to assume absolute control in the present."

The journalist/translator noted this was the principal reason Ernetti gave for not divulging details of the chronovisor: "He was afraid villains would steal it and use it to control the world." Jones quoted Father Ernetti as saying that for a year-and-a-half he couldn't leave the monastery of San Giorgio Maggiore unless he was accompanied by two bodyguards because "the American and Russian intelligence agencies had taken an interest in him and had sent spies to shadow his every move."

Helena R. Olmo, a Spanish journalist who spent three months in Italy in 2000 researching Father Ernetti for a forthcoming book, says that, according to her sources, both the Vatican Secret Service and the Italian Secret Service detained someone in 1965 who they thought had sold information to the



Father Ernetti performing an exorcism

to be 40,000). In our own times, past-life regressionist and author Dr. Chet Snow has described, in *Mass Dreams of the Future* (1989), how he and Dr. Emily Wambaugh "future-life progressed" thousands of volunteers ostensibly into the future. Remarkably, those regressees who returned with memories of an encounter with the future described one of only four different futures—a statistically significant figure given that hundreds of volunteers "returned" with such memories. And, in 2000, dentist, hypnotherapist and author Dr. Bruce Goldberg published the controversial *Time-Travelers from the Future: A Fifth Dimension Odyssey* (2000), which purports to detail his many encounters, while in a hypnotic trance, with the earth of the future, up

Continued on page 68

Share a
Little Light
with Your
Friends

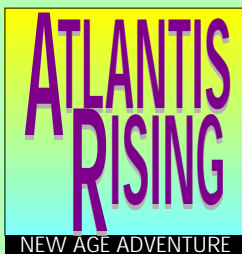

Send **SIX ISSUES** of
the magazine for
New Age Adventure
to **TEN of YOUR**
FRIENDS for
only **\$125⁰⁰**

Now you can order
ten subscriptions to
ATLANTIS RISING for
for the price of five.

Just jot down the
names of your ten
favorite people,
call our toll free
order line and use
your Visa or
MasterCard now.
What could be
easier?

1-800-228-8381



MICROHYDRIN

LONGEVITY'S MISSING LINK
ANTI-AGING MIRACLE REVEALED

Author, scientist, child prodigy Patrick Flanagan's greatest invention. Nobel Prize Submitted technology has now made a miraculous natural way to slow down the aging process giving you more energy and alertness than ever before. One capsule is equal to 10,000 glasses of freshly squeezed organic orange juice.

CALL TOLL FREE FOR A FREE TAPE OR MORE INFORMATION

888-313-6170

www.goldenangelsrbc.com

ATLANTIS RISING

Cover Art
by Tom Miller



Antarctica



The Hourglass



Asteroid



Diving Lemurian Waters



Stonehenge



The Templar

Gorgeous reproductions suitable
for framing. Signed by the artist.

11"x17" **\$30⁰⁰** each. **\$150⁰⁰** for the complete set Add \$4 for S&H



FREE with each set of 6, Tom Miller's haunting orchestral tribute to
ANCIENT WORLDS on stereo cassette! A \$9.98 value

Send check or money order to
Tom Miller • P.O. Box 441 • Livingston, MT 59047 • PH 406-222-6733

Russians on work being done on the chronovisor in Venice by Father Ernetti. "The incident was mentioned in the Russian press," says Olmo, who lives in Madrid.

Has the U.S. government—perhaps in some future form—suppressed time travelers? "I don't know," ponders Ernst Meckelburg, "but if you look at the bizarre 2000 American presidential elections, to cite just one example, you can see that anything is possible." Meckelburg has long wondered if the collapse of the Soviet Union and the reunification of Germany "might have been arranged from our very future."

George Andrews, well-known author of such works as *Extra-Terrestrial Friends and Foes* (Illuminet Press, 1993), notes that Father Ernetti was at the peak of his activities at about the same time the CIA's MK-ULTRA project meant to explore the possibility of time travel and much else, was itself in full swing. Andrews remarks that the research of the well-known, respected—and talkative—Benedictine priest could not have escaped the notice of the CIA—or the KGB or any other major intelligence agency.

Pointing out that it was at this time that the CIA was administering LSD on a large scale to witting and unwitting test subjects, Andrews wonders if Ernetti himself might have been the victim of such a procedure. He wonders in addition if the notorious, rumored Radio Hypnotic Induced Memory (RHIC-EDOM) technique—might have been used on him to ensure that the priest, his ground-breaking ideas appropriated by the CIA, said no more about them or even remembered anything more about them than the government agency permitted.

The shock of such a violently imposed procedure to Father Ernetti's belief system, Andrews speculates, may have been such that the Benedictine "resorted to deception, not so much to deceive other people, as to provide a fantasy solution for himself—to pre-



Ernst Meckelburg

serve his own sanity." Herein, suggests Andrews, may lie the key to the maddening ambiguity and ambivalence which dogged the Venetian priest's references to the chronovisor during the latter part of his life.

Conflicting stories continue to emerge about Ernetti, even regarding the accounts of his death. *Father Ernetti's Chronovisor* contains a chapter the editors believe was sent to them by a distant relative of Ernetti in which the priest, while on his deathbed, repudiates to a degree his experience with the chronovisor.

Helena Olmo says she interviewed Ernetti's 80-year-old sister, who gave a somewhat different account of Ernetti's last hours. "We had very solid reason to believe that the version we received was absolutely authentic," muses Jones. "Now, we're wondering if disinformation was not involved."

The Vatican steadfastly refuses to either affirm or deny Ernetti's claims, according to the translator/journalist. "You can explain this by saying they were embarrassed by this nut who wouldn't stop talking about ridiculous things,"

he says. "Or you can believe that Father Ernetti was onto something, and that the Vatican suppressed it. After all, the chronovisor would have shown whether there were flaws in the Church's teachings on the life of Christ."

Jones says a cover-up may well have been a part of the Baird T. Spalding story (also told in detail in *Father Ernetti's Chronovisor*). "For sure, a great deal of what Spalding said about himself during his lifetime was absolutely untrue. So was a whole lot of what Doug DeVorss said about Spalding. But DeVorss was in touch with Spalding on a daily basis for years, and often traveled with him. He must have known the truth.

"But despite all these untruths, Baird T. Spalding was incredibly knowledgeable in many areas of esoteric learning. How did he acquire that knowledge? Doug DeVorss was murdered at just about the time people were beginning to ask questions. Now we'll never know." ■

Continued from Page 41

production of iron until that time. Instead, cast iron was apparently manufactured in China from this early date on, and the techniques of the indirect process were evolved."

Iron is traditionally said not to have been worked in the Americas. Says van der Merwe, "In the New World, iron cannot be said to have achieved any widespread use before Colonial times. Small quantities of trade iron, however, penetrated to Northern Alaska by way of Siberia. Iron has been found in an early context in a site of the Ipiutak culture at Point Hope, Alaska; on the other side of the Bering Strait, iron occurs in an Old Bering Sea site at Uelen on the Chukchi coast. Both of these cultures have been dated to about A.D. 300. Iron was not manufactured in the New World, however, until Viking colonists introduced it to Newfoundland around A.D. 1000."

Archaeologists, however, are ignoring the evidence for iron-smelting furnaces discovered in Ohio. Arlington Mallery in his book, *The Rediscovery of Lost America*, gives details on the discovery of several iron furnaces from southern Ohio that were used in prehistoric times. One furnace that Mallery uncovered in the Allyn Mound near Frankfort, Ohio was of a beehive type with charcoal and iron ore found inside. The mound was about 60 feet in diameter and seven feet high. Mallery compared the furnace to the primitive Agaria iron smelters still used in India.

Mallery's book had an introduction by Matthew W. Sterling, then Director of the Bureau of American Ethnology of the Smithsonian Institution. Sterling said in the introduction, "It will be difficult to convince American archaeologists that there was a pre-Columbian iron age in America. This startling item, however, is one that should not long remain in doubt. The detailed studies of metallurgists and the new carbon-14 dating method should be sufficient to give a definite answer on this point."

The Iron Pillar of Delhi

In the southern district of New Delhi is the famed Iron Pillar, generally believed to date from the fourth century A.D., but said by some scholars to be over four thousand years old. It was built as a memorial to a king named Chandra. It is a solid shaft of iron sixteen inches in diameter and twenty-three feet high. What is most astounding about it is that it has never rusted even though it has been exposed to wind and rain for centuries! The pillar defies explanation, not only for not having rusted, but because it is

apparently made of pure iron, which can only be produced today in tiny quantities by electrolysis! The technique used to cast such a gigantic, solid iron pillar is also a mystery, as it would be difficult to construct another of this size even today. The pillar stands as mute testimony to the highly advanced scientific knowledge that was known in antiquity, and not duplicated until recent times. Yet still, there is no satisfactory explanation as to why the pillar has never rusted!

To add to the evidence that ancient India had highly advanced smelting works, the monthly *Motilal Banarsidass Newsletter* from New Delhi, India reported in its July 1998 edition that findings by the State Archaeology Department after excavations in Sonebhadra district, Lucknow, India, may revolutionize history as regards to the antiquity of iron. The department has unearthed iron artefacts dated between 1200–1300 B.C. at the Raja Nal Ka Tila site in the Karmanasa river valley of north Sonebhadra.

Said the newsletter, "Radio carbon dating of one of the samples done by the Birbal Sahani Institute of Palaeobotany has established that it belongs to 1300 B.C., taking the antiquity of iron at least 400 years back, even by conservative estimates. This date of iron is one of the earliest in the Indian sub-continent."

And, these are conservative estimates indeed. As we have already seen, there is considerable evidence that mining and iron working have gone on long before 1300 B.C.. Indeed, if the futuristic (it seems odd to call tales of the past "futuristic") epics of ancient India are any indication, there must have been a great deal of metallurgical activity in ancient India, starting over 20,000 years ago!

The Mysterious Origin of Aluminum

In 1959 Communist Chinese archaeologists claimed that they had discovered ancient Chinese belt buckles in a tomb. They were several thousand years old, the newspaper accounts said, but, incredibly, they were made of aluminum. Aluminum is a curious metal, because the smelting process from bauxite requires electricity!

The modern process for extracting aluminum from bauxite was not perfected until 1886. This discovery, as well, is very curious. Most aluminum produced today is made from bauxite.

First discovered in 1821 near Les Baux, France (from which its name is derived), bauxite is an ore rich in hydrated aluminum oxides, formed by the weathering of such siliceous aluminous rocks as feldspars, nepheline, and clays. During weathering the silicates are decomposed and leached out, leaving behind a residue of ores rich in alumina, iron oxide, titanium oxide, and some silica. In general, economically attractive ores contain at least 45 percent alumina and no more than five percent to six percent silica.

Most of the large bauxite deposits are found in tropical and subtropical climates, where heavy rainfall, warm temperatures, and good drainage combine to encourage the weathering pro-

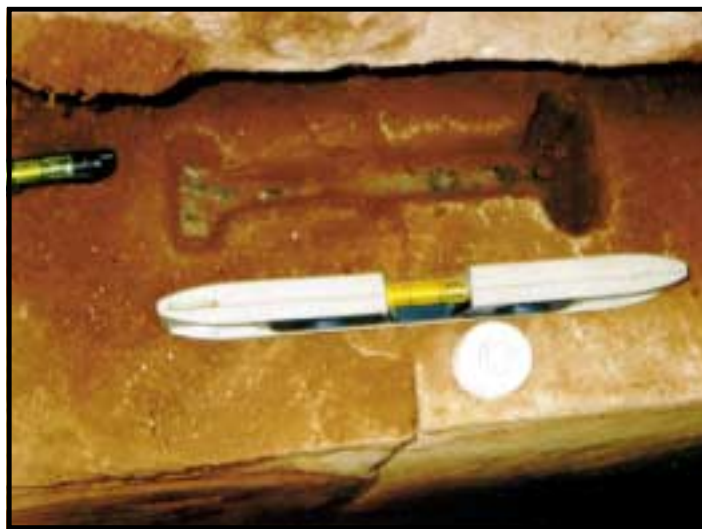

In Peru's Kalasaya temple a slot for a bronze brad from thousands of years before bronze age (Bill Cote).

cess. Because bauxite is always found at or near the surface, it is mined by open-pit methods. It is then crushed if necessary, screened, dried, milled, and shipped for processing. Australia, Guinea, Jamaica, Brazil, and India are leading bauxite producers.

Although proof of the existence of aluminum as a metal did not exist until the 1800s, clays containing the metallic element were used in Iraq as long ago as 5300 B.C. to manufacture high-quality pottery. Certain other aluminum compounds such as the "alums" were used widely by Egyptians and Babylonians as early as 2000 B.C.. Despite these early uses of the "metal of clay," however, it was almost 4,000 years before the metal was freed from its compounds, which made it a commercially usable metal.

Credit for first separating aluminum metal from its oxide goes to the Danish physicist, Hans Christian Oersted. In 1825 he reported to the Royal Danish Academy that he accomplished this by heating anhydrous aluminum chloride

with potassium amalgam and distilling off the mercury. His product was so impure, however, that he did not succeed in determining its physical properties beyond observing a metallic luster.

In 1845, after many years of experimentation, Friedrich Wohler succeeded—by substituting potassium for the amalgam—in producing globules of aluminum large enough to allow the determination of some of its properties. In 1854, Henri Sainte-Claire Deville substituted sodium for the relatively expensive potassium and, by using sodium aluminum chloride instead of aluminum chloride, produced the first commercial quantities of aluminum in a small plant near Paris. Bars and various objects made of this metal were shown at the Paris Exposition in 1855, and the ensuing publicity was in large measure responsible for launching the industry.

In 1886, Charles Martin Hall of Oberlin, Ohio, and Paul L. T. Heroult of France, discovered and patented almost simultaneously the process by which alumina is dissolved in molten cryolite and decomposed electrolytically. This reduction process, generally known as the Hall-Heroult process, has survived many attempts to supplant it; it remains the only method by which aluminum is produced in commercial quantities today. The inventors' families made millions, and ultimately billions, of dollars. Aluminum is made all over the world, usually where bauxite can be found and electricity is cheap, such as at hydroelectric plants.

Aluminum is the most abundant metal on the planet, but requires electricity to create metal in a usable form. Indeed, the invention of aluminum extraction is of incalculable benefit to mankind, providing us the advanced metallurgy science that is necessary for inventions such as flight and space travel.

The belt buckles discovered by the Chinese in 1959 make us wonder, were these artifacts made using electricity? The aluminum smelting process from bauxite requires electricity! French scientists studied the buckles and published their studies in 1961. They concluded that the ancient Chinese were making aluminium by an unknown process. ■

The belt buckles discovered by the Chinese in 1959 make us wonder, were these artifacts made using electricity? The aluminum smelting process from bauxite requires electricity! French scientists studied the buckles and published their studies in 1961. They concluded that the ancient Chinese were making aluminium by an unknown process. ■

Excerpted and edited, with the author's permission, from Technology of the Gods, Adventures Unlimited Press.

ANCIENT ARMAGEDDON

Continued from page 43

Numerous Hittite cities—built with giant, megalithic slabs of stone—were curiously melted and fused during some catastrophic event that occurred in their distant past.

Scotland, on the other hand, a land of green mountains and skirt-clad men playing bag-pipes, is not exactly the place where you'd expect to see vitrified ruins, but there they are.

Other places around the world where melted and fused stone blocks have been found include the Gobi desert in northern China, Iraq, Easter Island in the southeastern Pacific, Jericho, and amazingly right here in the United States. There are ancient, mysterious ruins in Death Valley, California. The ruins are so old that the native people there—the Shoshone Indians—have no idea who built them. They are extremely eroded and are credited to the 'Gods.'

One last item of interest in terms of archaeological evidence for nuclear warfare in the past are some strange skeletons that were unearthed at the ancient sacred city of Mohenjo Daro in Pakistan.

During excavation, scientists unearthed a level of debris where skeletons were scattered everywhere. Laying haphazardly in the dust, these bones alerted experts that something very unusual had happened. Normally skeletons are found neatly laid out in ceremonial garments and buried with their worldly possessions in either tombs or graves. But this new discovery showed something else entirely.

(Mohenjo Daro, by the way, was one of the sacred cities in the Rama empire the empire made famous in the ancient Indian epic, the Ramayana.)

When archaeologists reached the street levels of the city, they found bones scattered everywhere in disarray—just lying dead in the streets. Some were even holding hands. It was as if these scattered individuals had been caught unaware by some horrible doom. (Perhaps they were fried so fast, they didn't know what hit them.)

The really shocking piece of information to come from this dig, however, came later. Oftentimes ancient artifacts are dated according to carbon-14 analysis and other sophisticated techniques. The data which came out of the labs for the Mohenjo Daro skeletons, however, caught everyone off guard. When the tests for radioactive content were completed, the skeletons were found to be not only 'hot', but very hot. In fact, they were among the



Bodies in the street in Mohenjo Daro

most radioactive skeletons ever found—comparable with those found in Hiroshima and Nagasaki!

And this is especially disturbing when we take their extreme age into account. After all, the radiation has had thousands of years in which to dissipate, yet the skeletons are as hot as freshly cooked specimen from just a few decades ago! One was found to be radioactive at more than fifty times the normal level!

To Bomb, or Not to Bomb

It's interesting that the weird greenish glass (mentioned earlier) was discovered beneath the debris of the cave-man era. Generally in archaeology, each new settlement or civilization is built on top of the old one. The further you dig, the older the artifacts.

Following this path of logic, if the green glass was under the cave-man rubble, then it must be older. Thus the evidence suggests, if the greenish glass did indeed come from the heat of an atomic explosion, it must have destroyed any technologically advanced civilization that had developed up to that point.

Imagine, if you will, a series of bombs that shake the very foundations of the world. The planet rocks, reels, tips sideways, changes rotation and shifts on its axis. Nearly all life is destroyed and you are one of the few lucky survivors left to tell about it. What would you do? Where would you go? There would be no more cars, no more telephones, no more computers or internet, no more color TV, no more Hollywood, no more convenience stores or diet sodas... just dirt and rocks!—and you're damn lucky to have THAT.

Well anyway, the world is crashing around you—tornadoes, hurricanes, volcanoes and utter madness. You're runnin' and you're very scared. You decide to find a nice sturdy cave to stay in for awhile. Pretty soon after things start to die down, you begin to put on animal skins to stay warm and hunt with bows and arrows.

Civilization is back to square one.

Eventually, after many generations, people will forget that there ever was an advanced civilization at all. And if any legends do survive, they will be treated like somebody's wild flight of

the imagination.

Just such an occurrence seems to have happened in our own history. The evidence is there. There are weird, ancient, unexplained ruins all over the planet from people that have been totally wiped out. No one knows how the ruins got there—or what happened to the civilizations that built them. Even under the Atlantic Ocean some say there are temple walls, roads, pyramids, stairways, and so on. (I almost feel sorry for the poor suckers who used to live there.)

Ancient ruins, if they exist, on the bottom of the Atlantic—remains of the 'legendary' continent which, for the sake of argument, we'll call Atlantis—would be evidence enough of a world-wide cataclysm.

Some stories insist that survivors who escaped their sinking homeland journeyed to Egypt with an assortment of books—preserving the knowledge of the doomed continent.

A number of researchers have made it their personal quest to find these ancient texts. And according to obscure references they are enclosed in a special secret place called the 'Hall of Records.' The most popular notion is that this hall of records, furthermore, is hidden beneath the Sphinx. After all, the Sphinx's erosional patterns have been shown to date it back to a time before the Sahara became a desert—over ten thousand years ago.

Just what might be in this 'Hall of Records'? ... Profound knowledge? Mystical formulas? Secrets of the universe? ... What?

Think about it. If you had just survived something horrendous—a really traumatic event where everything was just blown to bits and flooded over—What would you write about? If everyone you ever knew or loved was dead ... and your house was gone, your car was gone, your kids were gone, your friends were gone... everyone was gone... What would you do?

If there was a group of survivors who'd escaped from Atlantis (or from anywhere else, for that matter), what would they tell us? If they left any ancient tablets behind at all, and sealed them up in a special 'Hall of Records', what profound knowledge could they impart to future generations?

Could it be the secret of peace on Earth? ■

Sylvia Dailey was an army journalist for the Pershing nuclear missile unit during the early 1980s. She's written and illustrated a child's book on imagination, as well as a kid's chapter book: LIVING PTERODACTYLES—and Other Non-Extinct Dinosaurs. She's currently working on a book about ancient nuclear warfare.

JUDY JACKA

Continued from Page 45

exact location of our Vivaxis, it is important to find the exact direction in which it lies. Another technique involves "tapping" a body part sharply with the heel of your hand to break up disturbed energies (exposure to x-rays and many electronic devices scatters the energy within our bones), then applying pure charcoal to the stimulated parts (Jacka says wrists, elbows, shoulders, knees, the coccyx, the jaw, and areas previously x-rayed need particular focus). This realigns the carbon atoms within the bones to true north and south, the appropriate directions for carbon and its counterpart, calcium. Since our bodies have an electric and a magnetic field lying at right angles to each other, energies from the Vivaxis flow into us vertically through our left side and from us to the Vivaxis horizontally from our right. When the energy flows of our Vivaxis are disturbed by interferences from chemical, electromagnetic or psychological sources, any of which can cause a diminished or chaotic energy flow through the body, both the immune and nervous systems are compromised.

Disturbances can also come from x-rays, diathermy, electrocardiographs, electrolysis—even from treatments offered by "natural therapists" employing electronic diagnostic units which use electrodes or probes touching the hands. And certainly, computer and TV equipment are culprits. Studies show that pregnant women spending hours at the computer show more fetal abnormalities; "but," notes Jacka, "these are probably also women who need antioxidants." In her opinion, it's a good idea to take a gram of vitamin C morning and evening. "Vitamin C can be a huge help; when your biochemistry is strong, you are much more able to withstand electrical interferences." She has found that disruption can also occur through synthetic fabrics, hypnotherapy or the use of magnets, something which Nixon warned against. "The magnetic field of the body is extremely sensitive," explains Jacka, adding that; "Even a tiny battery in a watch can affect it."

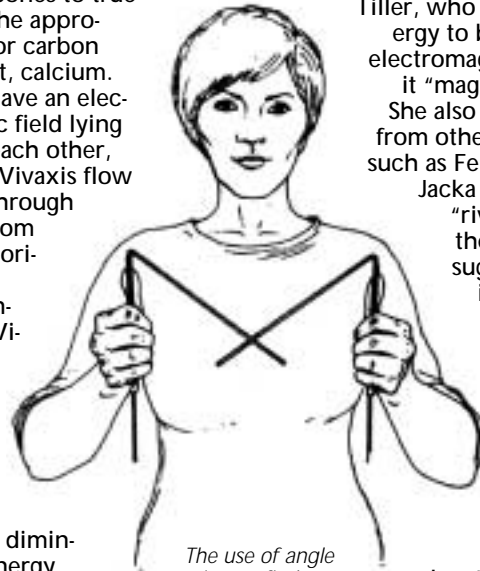

The use of angle wires to find our Vivaxis. When we are directly facing our Vivaxis, the points of the wire cross evenly. We should not think of anything but our Vivaxis during the process. (The Vivaxis Connection, Page 10)

Jacka has long been interested in subtle energies; "My training in the Trans-Himalayan teachings transmitted by H.P. Blavatsky and Alice Bailey, together with the study of natural therapies, attracted me to etheric energies, which comprise the more subtle part of our physical bodies. The etheric world forms the interface between our physical brain consciousness and other levels of consciousness," she says.

Jacka distinguishes between etheric and psychic energies, which she says are derived mostly from the "astral body" of human desires, and can color the intuitive ability needed in attuning to Vivaxis energies. She likes the definition used by Physicist William Tiller, who considers etheric energy to be the counterpart of electromagnetic fields, terming it "magnetolectric energy."

She also distinguishes Vivaxis from other earth energy work, such as Feng Shui and ley lines.

Jacka describes ley lines as "rivers running through the Vivaxis layers," and suggests that the planet is composed of many different electromagnetic frequencies and grids through which these currents and frequencies are transmitted. She believes that "the ley system is associated more with the planet itself and is not connected to the human system."

While Jacka says she has found her study of Earth energies to be "the most amazing aspect of health and healing I have encountered during thirty-five years of study in the area of natural therapies," she says she

doesn't use it on every patient. "I have built my professional reputation and have helped thousands of people with diet, vitamins and herbs," she states, "and only when those remedies don't seem to be effective do I suspect and then look for a disruption in the energy field."

If she does find such a disruption, the "Vivaxis tool" then becomes indispensable. "Let's say someone comes to me with headaches and exhaustion," she poses. "I would 'scan' them using my 'dowsing sense' (also called "radiesthesia," this is clairsentience—an amplification of the sense of touch); assuming I find disturbed energy, I would then check for a 'foreign' field. If they reported having had exposure to electrical sources I would have them do a→

JUDY JACKA

neutralizing exercise on a previously marked (Jacka uses golf tees) energy layer. This involves pressing the fingertips together while keeping the feet and toes pressed together for about five minutes. I would then have them exercise on each of the layers." She mentions that apartment dwellers are at a disadvantage in finding energy layers; a gentle slope on at least 1/2 an acre is necessary in order to map the layers and be able to stand on them.

Though she acknowledges the detrimental forces which surround us, and bemoans the lack of awareness of widespread electromagnetic assaults, Jacka is positive about the future of the planet. "You have to have a positive outlook," she states. While there are seemingly endless electromagnetic frequencies which can have detrimental effects on our health, or harm, pollute or destroy someone's Vivaxis, there is good news: If our Vivaxis is completely destroyed, another is created almost instantaneously. And, as Jacka demonstrates in the 29 exercises in her latest book, there are many simple and inexpensive ways we can correct and strengthen the connection to our Vivaxis.

She recently tested a few of the exercises during a seminar in Athens, Greece, which she conducted for a large group of people who smoked and drank lots of coffee, Jacka doubted that a single session would yield appreciable results. "I was amazed to find that just by going to the park, waving our arms around and applying charcoal to places on the body resulted in almost everyone feeling markedly better," she remembers.

Jacka points out that Nixon's work was often done in consultation with

physicists, and notes that William Tiller, Professor of Material Sciences at Stanford University, was instrumental in Nixon's discovery of "Vivaxis receptors" on the body. "These receptors," notes Jacka, "have been determined to be the acupuncture points along the 12 major meridian lines, and seem to have

had helped people regain the ability to walk after paralysis by working to unblock brain receptors.

A fascinating aspect of Vivaxis work is the correlation between the layers and the energy centers, or chakras, in the body (which themselves are associated with the endocrine glands). In particular, the pineal gland seems to be associated with a magnetic focusing apparatus that gives us a "homing" instinct. Medical researcher Robert Becker supports scientists' findings that most living creatures have a built-in sense of direction, manifest in a substance embedded in the head called magnetite. "The organ containing magnetite is closely connected to the brain, and has been unequivocally shown to be a sense organ that informs the organism of the Earth's magnetic field," he states.

As we become more aware of our own magnetic forces, we may well become sensitive to those of the Earth. Even as "Gaia" faces her hour of peril, attention is shifting towards her rescue. From environmentalists to scientists to stars, we are collectively becoming sensitive to her plight and to our dependency on her continued health for our own nurturance and survival. Perhaps we will find an unexpected spiritual connection that will assist us in birthing a new era.

As Shirley Mac-Laine writes in *The Camino: A Journey of the Spirit*, "...I came to believe that the surface of the earth is the matter and form through which a higher subtle electromagnetic spiritual energy flows. Just as human beings are the physical vehicles for expressing their spiritual and multidimensional selves, so the geological earth is the physical vehicle for manifestation of ancient memories and an alive inner spirit." ■

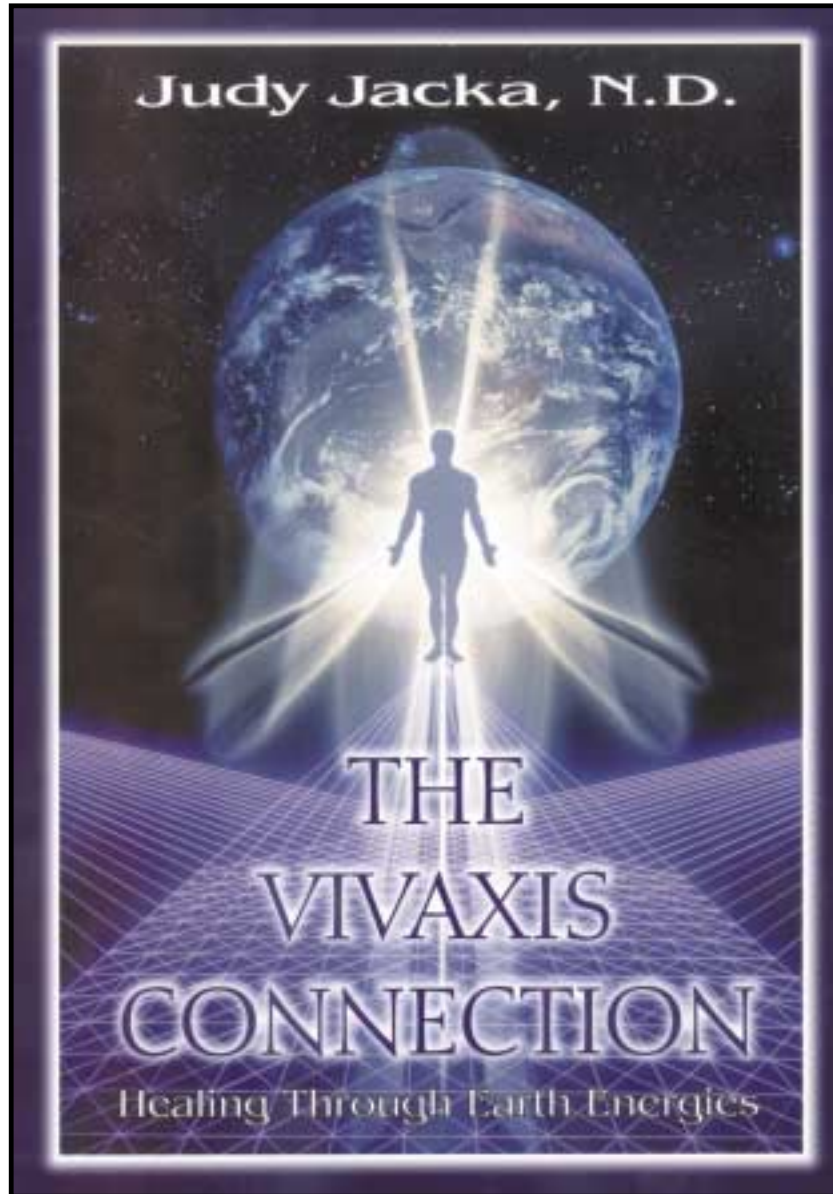

at least an indirect relationship to the neuropeptide receptors described by Dr. Candace Pert (author of *Molecules of Emotion*). Nixon demonstrated that each receptor point responds to a particular mineral frequency. Each a tiny transformer, the receptors mediate between the Vivaxis and the Earth. When blocked, it is "short-circuited" and can no longer function. Receptors in the brain are particularly important for memory, creative thinking and movement. Jacka recalls Nixon stating she

RUSSELL TARG

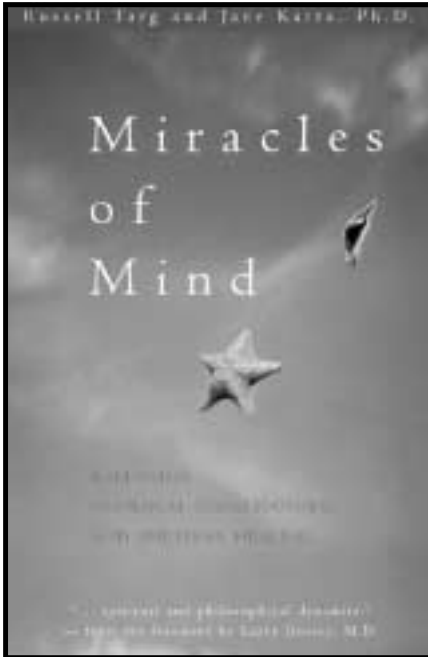

Continued from Page 47

thanks at mealtimes and other expressions of gratitude.

He has been well ever since. Blood tests and x-rays show no sign of illness! Whether or not cancer was a misdiagnosis, Katra saved him from chemotherapy.

Targ and Katra now write about the difference between psychic and spiritual healing—loving-your-neighbor-as-yourself. Realizing that people are truly connected even at far distances, “do unto others as you would have them do unto you” has new meaning.

A form of psychic connection—distant hypnosis—is similar to spiritual healing in that they both involve exchanging of information in ways that we don’t understand. Targ and Katra see distant-hypnosis as *separating* people mentally or psychically. One person wills a specific outcome for another, whether or not the other wants that outcome. In contrast, distant spiritual healing comes from a *joining* of minds, resonance, and entering a universal consciousness. “It involves a surrender of individual will on the part of the healer, with no personal effort exerted, no specific outcome designated—a ‘letting’ instead of a doing.” The willingness to be used for the well-being of another in an impersonal, non-emotional way has been called compassion or love. Katra and Targ say that state activates spiritual healing.

Regarding experiences such as remote viewing, they conclude that narrowly focusing on phenomena, no matter how fascinating, may be a trap.

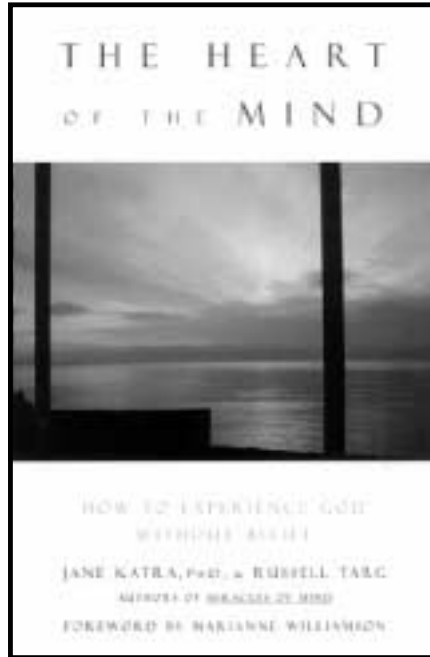

The excitement may prevent us from discovering who we really are. Playing with extrasensory perception (ESP) makes us feel omniscient; that may keep us from finding out what we should be doing in life. On the other hand, Targ and Katra indicated in their 1999 book *The Heart of the Mind* that when any person demonstrates an extraordinary ability, it can inspire the rest of us with the immensity of the largely undeveloped human potential.

Russell Targ provides what I see as an encouraging example to other scientists who may be tentatively peeking over the virtual Iron Curtain that divides skeptics from those who admit to believing in a Divine Intelligence. He shows that you don’t have to leave your scientific thinking at the door when entering the domains of spiritual awareness. As a dinner companion, for example, he effortlessly exhibited the sophisticated intellect that is so admired by academics, along with subtle humor and a sense of irony about his situation. Still skeptical on various topics, he does not even embrace the concepts of zero-point energy that have been championed by his famous colleague, Dr. Puthoff.

However, on the topic of nonlocal consciousness he does not hesitate to handle “spiritual and philosophical dynamite.” ■

Russell Targ and Jane Katra, Ph.D., Miracles of Mind: Exploring Nonlocal Consciousness and Spiritual Healing, New World Library, CA, 1998.

Targ and Katra The Heart of the Mind: How to Experience God Without Belief, New World Library, CA, 1999.

The science fiction of “beaming” objects from place to place is now a reality—at least for particles of light”

Scientific American, April 2000



Now, join the dreamers, who have a zest for life and the courage to face the unknown!

If you like unusual projects and have an open mind—this adventure could be for you!

Where are We Going? We Are Going Home...

www.magic4art.com

for details

ANCIENT WORLDS
INSTRUMENTAL MUSIC BY TOM MILLER
Comments by Jane Katra, Ph.D.

“It’s amazing...I felt transported to a different time and place. It took me into the past but it also prepared me into future possibilities and into a higher level of consciousness.”
—J.J., a Producer, Minnesota

“Tom Miller’s music is New Age, but it’s also ancient and timeless. It speaks to the soul.”
—G.W., Executive, Florida

TITLES INCLUDE:
“ATLANTIS: THE LIGHT AND THE DARKNESS”
“THE MISTS OF LEMURIA”
“THE LOST CITY OF THE SAHARA”
“THE HEART’S ETERNAL LONGING”

ANCIENT WORLDS
Stereo Cassette \$9.98
Please add \$2.00 for shipping and handling

Send Check or Money Order to:
Tom Miller • PO Box 441 •
Livingston, MT 59047 • Ph. 406-222-6733

the ATLANTIS RISING Catalog

HERE'S THE WORK OF RESEARCHERS WHO ARE CHANGING THE WORLD

*Order the Books, Videos and More that Everyone is Talking About
If You Can't Find it Here Check Our Previous Issues or Call Us.*

BOOKS Alphabetically by Title

12TH PLANET *Zecharia Sitchin*—The product of thirty years of intensive research, *12th Planet* is the first book in Sitchin's *Earth Chronicles* series—offering powerful evidence of humanity's extraterrestrial forefathers.

Paperback, 436 pgs., black & white illustrations \$6.99
Hardcover \$22.95

ANTIGRAVITY: THE DREAM MADE REALITY *John A. Thomas, Jr.*—The incredible saga of John R. R. Searl from childhood construction of gravity defying toys to the building of full scale working devices many years later—the latter leading to intense government suppression efforts. Now the inventor's heroic researches are being published in a series called the "Law of the Squares". This book is a primer to the series and gives the background events leading to his renewed effort to give this technology to the world before it's too late.

7x10 Paperback, black and white illustrations and pictures, 125 pages \$25.00

THE BIGGEST SECRET—The Book That Will

Change the World *David Icke*—An extremely controversial book that strikes at the heart of most of our accepted belief systems, with very shocking and surprising information regarding religion, nations, and life as we know it. Well researched, it will make you think.

Paperback, 9 X 7, 517 pages \$25.00

BEYOND THE BIG BANG

Paul LaViolette

Explores the astonishing parallels between cutting edge scientific thought and creation myths from the dawn of civilization. Blending modern systems theory with the ancient notion of an underlying medium, or ether, LaViolette explains in direct, nontechnical language how ancient myths and esoteric lore encode a theory of continuous creation, one in which matter is continually growing from seeds of order that emerge spontaneously from the surrounding subquantum chaos.



Hardcover \$29.95

BLOODLINE OF THE HOLY GRAIL *Laurence Gardner*

Did Jesus marry and have children? What happened to his family? Are his descendants still alive today? This book reveals the sacred lineage based on actual historical records. Using his personal access to the sovereign and knightly archives of Europe, and to Templar and Vatican records, Gardner has compiled one of the most amazing histories ever written.

Paperback, Illustrated \$18.95

COMING ENERGY REVOLUTION *Jeane Manning*—A new and exciting revolution is coming, Jeane Manning tells us, that will dramatically change our landscape, environment, economy and lives. An intriguing and insightful look at the forces behind the free-energy movement.

Paperback, 230 pgs., black & white plates, 6 x 9 \$12.95

COSMIC CODE *Zecharia Sitchin*—Many thousands of years ago, a race of extraordinary beings guided the evolutions of life on Earth—determining the existence and nature of mankind as we know it today. All powerful, all knowing, the proof of their genius is apparent in the mysterious monoliths at Stonehenge, and in the strange but highly significant structure of concentric stone circles in Israel's Golan Heights—both requiring sophisticated astronomical knowledge.

Paperback, 298 pgs., black & white illustrations \$6.99

THE CRYSTAL SUN—Rediscovering a Lost Technology of the Ancient World *Robert Temple*

Based upon 33 years of research all over the world, in museums from Stockholm to Shanghai, from Athens to Cairo, and in thousands of books in several languages, Robert Temple has reconstructed a wholly forgotten story: the story of light technology in ancient civilization. It goes back at least to 2600 BC in Old Kingdom Egypt, and continues throughout Western antiquity. Unknown to our modern archaeologists and historians, a science of optics and a sophisticated technology for the manufacture of lenses was widespread and fundamental in ancient times. It inspired awe in cultures who used it, so that it permeated their mythologies and religions, and led even to a 'theology of light' in medieval Christianity. This is one of the most revolutionary studies in the history of science and civilization to be published for decades.

558 pages, 7X10, hardcover, 30 beautiful color illustrations as well as black and white pictures and drawings. (NOTE: Acquired From Foreign Distributor. Significant Delays Are Possible.) \$39.95

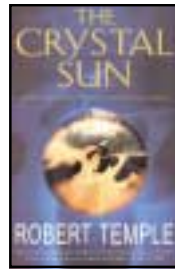

DIVINE ENCOUNTERS *Zecharia Sitchin*

\$6.99



THE DRAGON'S TAIL—Rediscovering the Tenth Planet How Long Until the New Ice Age

Anthony Austin, Brian Crowley

This book may prove to be the definitive casebook of humanity, reaching back some 15,000 years into the past and now made accessible by the researches of a diverse pair of lay scholars.

NEW!

Evidence presented here from history, science and astronomy reveals that earth undergoes dramatic climatic changes at 892-year intervals, creating a universal disaster of doomsday proportions.

246 pages, 8.52x5.52, P/B \$18.95

THE EMERALD TABLE—Alchemy for Personal Transformation

Dennis William Hauck

According to legend alchemy and the steps to achieve it have been encoded, hidden and secretly passed down from an ancient document believed to be originated by the gods. The Emerald Tablet



NEW!

is an absorbing tale of the history of the document and of the people who discovered it and used its principles to achieve a higher level of spirituality. Alexander the Great, Hermes, Thoth and ancient Egypt all play parts in this fascinating history.

452 pages PB, 5.31x7.93 \$16.95



EXCUSE ME, YOUR LIFE IS WAITING *Lynn Grabhorn*

How do we create this thing called the "Good Life"? Is there a way to have a fat bank account all the time, or a better job whenever we want one, or a delightfully smooth relationship, or a knock our heads against any more stone walls? And if so, is it really possible to have these lofty dreams now, instead of in some unknown future time? Grabhorn answers a resounding "Yes!" by showing us how the most unconscious thing we do all day long is what actually creates and molds every moment of every day of our lives. And what is this "thing" that governs so forcefully? Feelings!

309 pages 6x9 hardcover \$18.95

FALLEN ANGELS AND THE ORIGINS OF EVIL *Elizabeth Clare Prophet*

Did rebel angels take on human bodies to fulfill their lust for the "daughters of men"? Did these fallen angels teach men to build weapons of war? The author examines the controversy and sheds new light on the *Book of Enoch*, demonstrating that Jesus and the apostles studied *Enoch* and telling why Church Fathers suppressed its teaching that angels could incarnate in human bodies. Takes you back to the primordial drama of Good and Evil, when the first hint of corruption entered a pristine world-earth.



520 pages paperback \$7.99

USE YOUR CREDIT CARD (VISA, MC OR AMEX) AND CALL 800-228-8381 NOW

**10% Discount
on orders of
over \$100
(See page 81)**

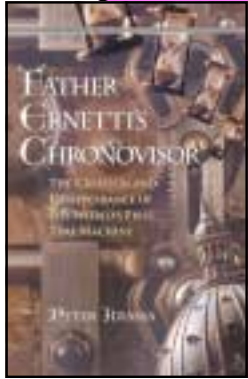

**FATHER ERNETTI'S
CHRONOVISOR—The
Creation and
Disappearance of
the World's First
Time Machine**

Peter Krassa—In the mid 1900's, an Italian Benedictine monk, Father Pellegrino Ernetti, was known as a highly respected priest, scientist and musicologist. But he claimed to have secretly created a time machine—the *chronovisor*, and asserted that

he was able to go back in time and witness specific events. His claims were hotly disputed. But we see here, the first translation from Latin, the text of "Thyestes" by Quintus Ennius, Rome 169 B.C., that Father Ernetti claimed to have brought back with him using the chronovisor. It and other documents make it impossible to dismiss his claims. To be published March, 2000.

224 Pages 6X9 \$16.95

FINGERPRINTS OF THE GODS *Graham Hancock*—Astonishing evidence pointing toward the existence of a forgotten epoch in human history—that of a highly advanced, technologically proficient and civilized society that flourished during the last Ice Age and was destroyed 12,000 years ago by global cataclysm. Hancock embarks on a worldwide quest to put together all the pieces of the vast and fascinating jigsaw of mankind's hidden past.

Paperback, 578 pgs. \$17.00

GENESIS REVISITED *Zecharia Sitchin*—Space travel, genetic engineering, computer science—astounding achievements that stunning new evidence proves were known to our forefathers millions of yesterdays ago, as early as 3,000 years before the birth of Christ.

Paperback, 343 pgs., black & white illustrations \$6.99

GIZA POWER PLANT

Christopher Dunn—Did a highly advanced civilization exist in prehistory? Is the Giza Pyramid a remnant of their technology? What was the power source that fueled such a civilization? In a brilliant piece of reverse engineering, Christopher Dunn reveals that the Great Pyramid of Giza created a harmonic resonance with the Earth and converted the planet's vibrational energies into microwave radiation. This may be the same technology discovered by Tesla and the solution to our own energy needs.

Paperback, black & white illustrations, 6 x 9 \$18.00

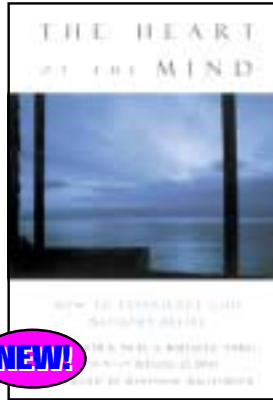
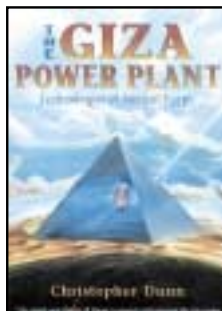

**THE HEART OF
THE MIND—How
to Experience
God Without
Belief** *Jane
Katra, Russell
Targ*

On the surface, this book is a profound and intelligent discussion of where mysticism and parapsychological science intersect. But at its core, this is a tender book about

NEW!

living a life of peace and feeling connected to universal love.

208 pages PB, 8.29x5.80 \$14.95

HEAVEN'S MIRROR—Quest for the Lost

Civilization *Graham Hancock*—Hancock continues the quest begun in his best-seller "Fingerprints of the Gods:" to rediscover the hidden legacy of mankind and to reveal that "ancient" cultures were, in fact, the heirs to a far older forgotten civilization and the inheritors of its archaic, mystical wisdom. Fully illustrated with hundreds of dazzling color photos, "Heaven's Mirror is a stunning and illuminating tour of the spirituality of the ancients—a search for a secret recorded in the very foundations of the holiest sites of antiquity.

336 pages 8X10 Paperback Photographs & Illustrations \$25.00

HIDDEN HISTORY OF THE HUMAN RACE *Michael A. Cremona & Richard L. Thompson*—Graham Hancock, calls *Hidden History Of The Human Race* "One of the landmark intellectual achievements of the late twentieth century." Condensed from *Forbidden Archeology*, this edition exposes a major scientific cover-up showing that people like ourselves existed on earth millions of years ago.

Paperback, 228 pgs., black & white illustrations, 6 x 9 \$15.95

HOLY BLOOD, HOLY GRAIL *Baigent, Lincoln, Leigh*

A detailed and meticulously researched insight into the history of the Catholic Church, and how it distorted the life of Jesus Christ in order to sell Catholicism to the world, gain power and riches. Presents the argument that a secret order with blood connections directly to Jesus has worked behind the scenes of world history to perpetuate its agenda. An excellent read for the open minded.

Paperback, 8 X 4 \$7.50

**JESUS, THE LAST OF THE PHARAOHS—The Truth
Behind the Mask Revealed**

Ralph Ellis—Traces the history of the Egyptian royal family from the time of Noah through to Jesus, comparing Biblical and Historical records. Nearly all of the biblical characters can be identified in the historical record—all are pharaohs of Egypt or pharaohs in exile. The Bible depicts them as being simple shepherds, but in truth they were the Hyksos, the Shepherd Kings of Egypt. The familiar Biblical story is a history of one family, Abraham and His descendants. In the historical record he is the pharaoh Maybra—the most powerful man on Earth in his lifetime. By such simple sleight-of-hand, the pharaohs of Egypt have hidden their identity, but preserved their ancient history and bloodline. These kings were born of the gods; they were not only royal, they were also Sons of God.

Hardcover, 6 X 9, 320 pages, Color Illustrated \$24.95

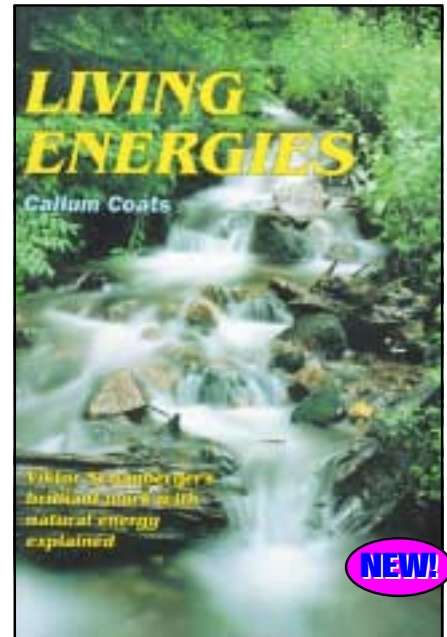

NEW!

**LIVING ENERGIES—Schauberger's Work with
Trees, Light, Air, and Water**—*Callum Coats*

The astonishing life and discoveries of maverick Austrian genius Victor Schauberger.

311 pages P/B 9.23" x 6.52" \$19.95

**THE LOST JOURNALS OF NIKOLA TESLA - HAARP -
Chemtrails and the Secret of Alternative 4**

Tim Swartz—Sensational data obtained from the inventor's most private papers and kept under wraps by the military and big business concerns. This book is for all those who feel that the military industrial complex is attempting to control our lives, our financial affairs and our belief structure. The evidence is overwhelming! Discredited in his time, Nikola Tesla was made out by business competitors and the government to be nothing more than a kook. Nonetheless, the same conspirators later duplicated—and possibly even stole—many of Tesla's most fabulous inventions which could soon change the course of history as well as our lives!

155 pages, P/B, 7x10 \$14.95

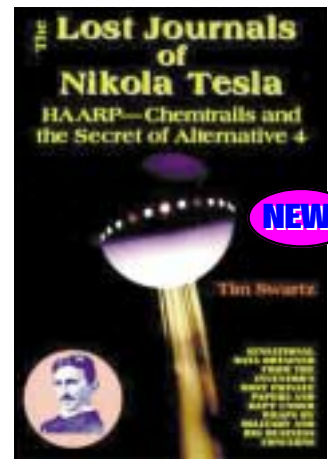

NEW!

LOST REALMS *Zecharia Sitchin*—With a visionary's ardor and a scientist's attention to detail, Zecharia Sitchin, author of *The Earth Chronicles*, gives a stunning account of human interaction with celestial travelers. He also provides further proof that prophetic dreams, visions, UFO encounters, and other phenomena, are the hallmark of intervention by intergalactic emissaries who reach out from other realms.

Paperback, 390 pgs., black & white illustrations \$6.99

USE OUR CONVENIENT ORDER BLANK ON PAGE 81

MORE GREAT BOOKS ON THE NEXT PAGE

LOST TREASURE OF THE KNIGHTS TEMPLAR

Steven Sora—Solving the Oak Island Mystery. Fascinating detective work connects the lost treasure of the Knights Templar to the mysterious treasure pit on Oak Island, Nova Scotia, that has baffled treasure hunters for two centuries.

Paperback, 308 pgs., black & white illustrations \$16.95

MAHABHARATA Translated by Krishna Dharma—Recounts the story of five heroic brothers, the Pandavas, who were destined to rule a vast kingdom. Robbed of their kingdom and exiled by their envious cousins, they encounter many hardships, culminating in an apocalyptic war. As we accompany them on their extraordinary adventures and spiritual journey, we meet Krishna, a divine incarnation. Because of Krishna's presence the "Mahabharata" is revered as a sacred text. It contains the "Bhagavad-gita", a masterpiece of spiritual wisdom, embraced by millions and one of the world's most significant treatises on karma, reincarnation, and yoga. Highly readable and beautifully illustrated.

940 pages 6X9 Hardcover \$39.95



NEW!

MEMORIES OF GOD AND CREATION—Remembering from the Subconscious Mind

Shakuntala Modi, M.D.—Psychiatrist Modi uses the technique of interviewing hypnotized patients to gather "memories" of cosmic and spiritual events—things that human kind has always sought to understand.

300 pages, P/B, 9.06" x 6.04" \$15.95

MIRACLES OF MIND—Exploring Non-local Consciousness and Spiritual Healing

Russell Targ, Jane Katra—Relying on their strengths—he a pioneering physicist and she a highly respected spiritual healer—Targ and Katra reveal scientific evidence and gripping stories to prove the extraordinary power of the human mind. Targ reveals for the first time the startling results of declassified CIA experiments in psychic spying during the Cold War.

352 pages, 9.02x6.05 P/B \$15.95

MYSTERIES OF ATLANTIS REVISITED Edgar Evans Cayce—From the hidden vaults beneath the Sphinx to the coastal waters of Bimini, three scholars explore the wisdom of Edgar Cayce and discover shocking new evidence about the destruction of Atlantis—and why striking parallels between our society and theirs could provide important lessons for the future.

Paperback, 214 pgs., 4.5 x 6.75 \$5.99

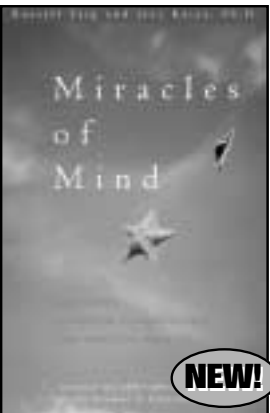

NEW!

the ATLANTIS RISING Catalog

10% Discount on orders of over \$100
(See page 81)

PASSPORT TO THE COSMOS—Human Transformation and Alien Encounters

John E. Mack, M.D.—The author powerfully demonstrates how the alien abduction phenomena calls for a revolutionary new way of examining the nature of reality and our place in the cosmos. Mack provocatively asserts (after having done additional research with abductees in the United States and around the world), that this phenomenon is part of a new age in human consciousness, a time in which we must be willing to embrace the idea that alien visitation is real on some level.

333 pages, 5x8, P/B \$14.00



NEW!

THE PK MAN: A True Story of Mind over Matter

Jeffrey Mishlove, Ph.D.—Mishlove's account of the extraordinary demonstrations of larger-than-life paranormal celebrity Ted Owens, who claimed to have "PK"—psychokinetic or mind-over-matter powers. Over the course of his life, Owens endlessly endeavored to prove to the world that he was in telepathic contact with "space intelligences" and that he could demonstrate special abilities as proof of this contact. Mishlove documents over a hundred compelling demonstrations of Owens' alleged powers, supported by witness interviews, affidavits and newspaper clippings of the events that transpired—including numerous "accidents" that occurred in proximity to Owens during his demonstrations. A revealing look into the psychology of the paranormal.

308 pages, P/B \$14.95



NEW!

RAMAYANA Translated by Krishna Dharma—Ramayana must rank as one of the most loved and revered books of all time. A part of India's ancient Vedas, it is a beautiful story of romance and adventure. It recounts the history of Rama, said to be an incarnation of the Godhead, and his divine consort Sita. Filled with magic and mysticism, it entrances the reader and stirs deeply moving emotions. At the same time its profound spiritual messages leave one feeling uplifted and enriched.

488 pages, 9.31x6.39 \$27.95



NEW!

RETURN OF THE PHOENIX: A Trilogy of the World Epic Michael Wells Mandeville—An anthology in three books of the stories and prophecies of Edgar Cayce, including a scientific assessment of their validity, a summary of Cayce's visionary story of the last 100,000 years of human history, and a complete presentation of his Millennial prophecy, which includes a shift in the location of the poles, catastrophic earth changes, an opening of the Hall of Records in Egypt, and the return of Y'shua to help the survivors recover. 1540 pages, charts and photos.

Book 1: The Veil

Paperback 6x9 \$28.95

Book 2: The Great Break Up

Paperback 6x9 \$24.95

Book 3: The Prophecies

Paperback 6x9 \$42.95
Complete Set \$87.95

SEARCH FOR LOST ORIGINS

Contains *Atlantis Rising's* great interviews with the likes of John Anthony West, Robert Bauval, Graham Hancock, Zecharia Sitchin, Rand Flem-Ath and many more. Plus incisive articles by Joseph Jochmans, David Hatcher Childress, David Lewis, J. Douglas Kenyon and others. Scores of photos and illustrations.

224 pages 5 1/2 x 8 1/2 Trade Paper 16 color photos \$14.95



SECRET CHAMBER

Robert Bauval

Explores the deeper layers of the Giza quest for a "Hall of Records" and makes the linkage between the ancient 'magical knowledge' and the Hermetic Tradition that carried it across the ages and into the mainstream of our modern western intellectual and esoteric tradition. (NOTE: Acquired From Foreign Distributor.)

Significant Delays Are Possible.)
Paperback 432 pages \$32.95

THE SECRET TEACHINGS OF ALL AGES—An Encyclopedic Outline of Masonic, Hermetic, Qabbalistic & Rosicrucian Symbolical Philosophy

Manly Palmer Hall—Simply put, this is the most beautiful and complete occult book ever published. It represents a lifetime of research into the mythology, symbolism, and magical practices of countless cultures. From the secrets of Isis to the teachings of mystic Christianity, nearly every occult dogma imaginable is represented here. Included is Hall's case for Francis Bacon as the author of the Shakespearian plays. The book is full of giant illustrations, some of which fold out into magnificent two-page splendor. This is the definitive guide to secret societies, famous figures, and more. A must for every personal library.

Paperback or Hardcover, 254 pages, Illustrated
PB \$54.95, HC \$69.95

SEEING RED: Red Shifts, Cosmology And Academic Science

Halton Arp A senior scientist's personal account of the crisis in modern astronomy. Dr. Arp presents observations showing that extragalactic redshifts are not caused by an expanding universe. He crafts us an empirical picture of the birth and evolution of quasars and galaxies, demonstrating that crucial observations have been ignored and suppressed by the astronomy community. Finally, he cites examples of how academic science fails its ideals and potential.

Paperback 310 pages, 6x9 \$25.00

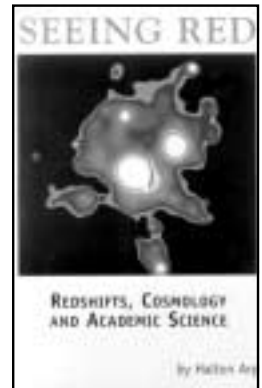

USE YOUR CREDIT CARD (VISA, MC OR AMEX) AND CALL 800-228-8381 NOW

THE SHAKESPEARE CODE Virginia M. Fellows

Traces the mysteries surrounding the identity of William Shakespeare and makes the case that he was actually Francis Bacon. Examines the evidence of a secret code hidden in the plays of the bard.

Paperback 315 pages \$19.95

SIGNS IN THE SKY

Adrian Gilbert — The prophets of the ancient world, in their search for a fixed calendar on which to inscribe the dates of events far into the future, looked to the skies. In a world before electric light, the fixed and immutable firmament shone down on the earth; the revolution of the stars and progression of the constellations of the zodiac were means of measuring the passage of time more accurate and lasting than any of man's invention. As great monuments and buildings of their era, the astrologically aligned pyramids record the progress of the years, counting down to the end of an age.

(NOTE: Acquired From Foreign Distributor. Significant Delays Are Possible.) Hardcover 345 pages, 10x13-1/2 \$52.95



SIRIUS MYSTERY Robert Temple—Superior beings from Sirius visited earth between 7,000 and 10,000 years ago, the extraterrestrial origin of human civilization. This claim, and Temple's sophisticated case, caused the world's top secret intelligence agencies to wage a fifteen year persecution campaign against the author. Draws on Temples astounding knowledge of ancient history, mythology, Pythagorean physics, chaos theory, and the African Dogon's belief that they were visited by beings from Sirius.

Paperback, 440 pgs., black & white illustrations, 6 x 9 \$19.95

STAIRWAY TO HEAVEN Zecharia Sitchin—After years of painstaking research—combining recent archaeological discoveries with ancient texts and artifacts—Sitchin has identified the legendary Land of the Gods...and provided astounding new revelations about the Great Pyramids, the Sphinx, and other mysterious monuments whose true meanings and purposes have been lost for eons.

327 pgs., illustrated, Paperback, \$6.99 Cloth, \$22.95

STAR ANCESTORS—Indian Wisdomkeepers Share the Teachings of the Extraterrestrials



NEW!

Nancy Red Star—"We came from the stars," say the creation stories of Indigenous people. Through interviews with American Indian spiritual leaders and striking illustrations of the work of prominent American Indian artists, the author explores the unifying Sky Elder theme found in virtually every Indian culture.

208 pages, P/B, 8x10, 55 color illustrations \$29.95

THE STARGATE CONSPIRACY Lynn

Picknett & Clive Prince Exposes the most insidious and dangerous plan of our time. Centered on the search for lost secrets of the pyramid builders, this extraordinary true story reveals the links between US scientific intelligence agencies, Mars and ancient Egypt. For almost 50 years, like Frankenstein's monster, this conspiracy has been put together from cultish—but astonishingly powerful—belief systems, culminating in the emergence of a new fundamentalism that is gathering strength by feeding on Millennium fever. The authors claim to reveal the secret agenda that unites apparently independent authors and researchers.

(NOTE: Acquired From Foreign Distributor. Significant Delays Are Possible.) Hardcover 320 pages \$42.95

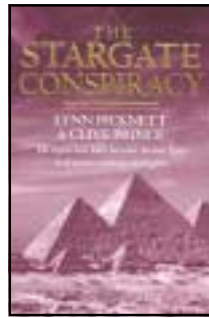

THE TALK OF THE GALAXY Paul LaViolette—First time proof of the existence of interstellar radio signals of intelligent origin. Evidence that pulsars are part of a vast network of ETI communication beacons.

6"x9" Paperback, 192 pages, black and white photographs and illustrations \$16.00

TEMPLE OF MAN R.A. Schwaller De Lubicz—

Twenty-eight years in the making, a monumental work that brings to life the greatness of ancient Egypt and the profundity of the human soul. Combines first rate scholarship with profound spiritual insight. Commentators liken reading The Temple of Man to a spiritual and philosophical odyssey. \$20 S&H on this item.

Clothbound with case, Two 544-page volumes, 400 black-and-white illustrations, 9 x 12, \$195.00

TECHNOLOGY OF THE GODS David Hatcher Childress—Technology of the Gods lays out the mind-bending evidence that long-lost civilizations had attained and even exceeded our "modern" level of advancement. Was the Great Pyramid of Egypt originally a gigantic power station? Was the Ark of the Covenant an electrical device? Has mankind teetered on the brink of atomic destruction in the past, and, in fact, fallen over the edge? Examine the eye-popping evidence that the ancients actually destroyed their extraordinary culture themselves!

Paperback, 9"x6", 343 pages, Black and White illustrations \$16.95



THOTH—Architect of the Universe Ralph Ellis — A fascinating reevaluation of the ancient monuments of Stonehenge, Avebury and Giza. These ancient monuments are nothing less than ancient maps, maps of our world that indicate the hidden location of the legendary "Hall of Records." And there is scientific proof of an ancient technical civilization...To be read with an open mind.

287 Pages 6X9 Hardcover Illustrated \$29.95

TIME TRAVEL: A HOW-TO INSIDERS GUIDE Commander X with Tim Swartz A former military intelligence operative with ties to secret government time travel experiments and an Emmy Award winning producer join forces to show YOU how to cross dimensions, enter vortex or window areas and experience stepping into the past or the future.

Paperback 141 pages, 7x10 \$14.95

THE TIME TRAVEL HANDBOOK—A Manual of Practical Teleportation & Time Travel Edited by David Hatcher Childress—

An authoritative chronicling of real-life time travel experiments, teleportation devices, and more, from the government to individuals like Nikola Tesla and Dr. John von Neumann. A highly visual book, with patents, photos and schematics.

271 Pages 7X10 Paperback \$16.95



ULTIMATE TIME MACHINE Joseph McMoneagle—McMoneagle, a former remote viewer with the United States Army's top-secret STARGATE project, explores questions philosophers have debated for centuries: Does time really exist? Can we change the past? Do we slip between alternate realities. McMoneagle also delivers first hand information about the origins of humanity, the building of the pyramids, the crucifixion of Christ, and a detailed picture of our immediate future through the year 2075.

Paperback, 275 pgs., 5.5 x 8 \$12.95

URIEL'S MACHINE Christopher Knight & Robert Lomas—

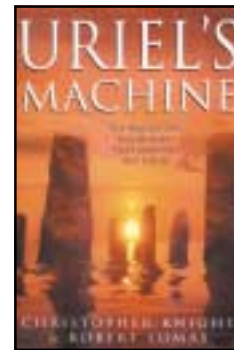

Putting together the latest findings of leading geologists with their own sensational new archaeological discoveries, they show how a civilization emerged and was able to build an international network of sophisticated astronomical observatories which provided accurate calendars, could measure the diameter of the planet and accurately predict comet impact years in advance.

They reveal that this is the true purpose of the great megalithic sites in Western Europe, built long before the Egyptian pyramids. Further they show that the Book of Enoch, long a part of ancient tradition of Freemasonry but then rediscovered among the Dead Sea Scrolls, contains precise details on the building of a machine in the reconstruction of a shattered world.

466 pages 7x10 hardcover, black and white pictures and illustrations \$27.95

THE VIVAXIS CONNECTION—Healing Through Earth Energies Judy Jacka—

The Vivaxis is your life axis, your energy "umbilical cord" to the planet. It is the place where you plug into the Earth and its life-supporting energies. Discovered by Canadian researcher Fran Nixon in the 1960s, the Vivaxis connection is fundamental to human life and health. It sustains and renews us, and affects every aspect of our lives—it even affects how we digest foods and resist illness. This unsuspected link between our body and a particular spot on the Earth can make all the difference between health and illness, says Dr. Judy Jacka, the world's leading authority on the new science of Vivaxis.



NEW!

304 pages, P/B, 9x7 \$16.95

USE OUR CONVENIENT ORDER BLANK ON PAGE 81

MORE GREAT BOOKS ON THE NEXT PAGE

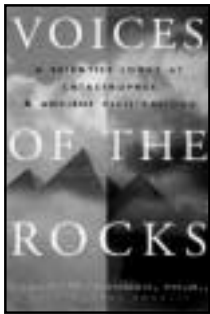

VOICES OF THE ROCKS

Robert Schoch—

Following the trail uncovered by his re-dating of the Egyptian Sphinx, Scientist and university professor Dr. Robert Schoch spearheads the scientific paradigm shift. This is the story of Schoch's own search for evidence of lost civilizations obliterated by Earth's long catastrophic history, and his warnings about how

to survive whatever catastrophes the future has in store.

Hardcover, 258 pgs., 8 pages of black and white plates, 6.25in x 9.25 \$25.00

WARS OF GODS & MEN Zecharia Sitchin—Eons ago, the Earth was a battlefield. Mighty armies clashed, led by giant warriors meticulously skilled in the art of combat. These wars would shape man's destiny and live on for centuries in legend, song and religious lore—brutal and terrible conflicts that began lifetimes earlier on another planet.

Paperback, 377 pgs., black & white illustrations \$6.99

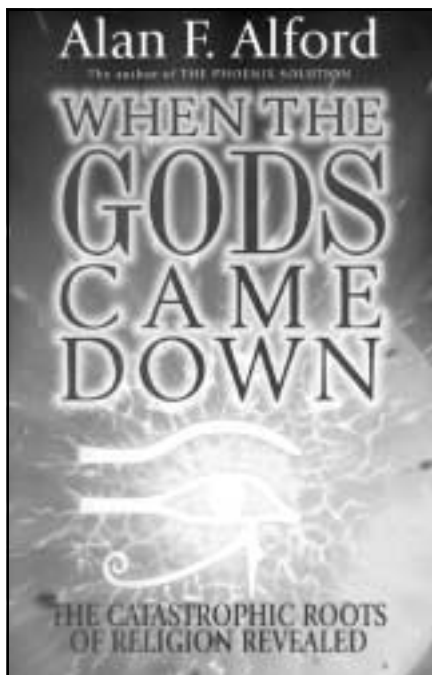

WHEN THE GODS CAME DOWN Alan F. Alford—Alford explains why religion as we know it is a 'dumbed down' form of a much older religious truth, which has been carefully hidden from the eyes of the masses. Beginning with 4,500 year-old sacred texts, Alford reveals that God was originally conceived as a celestial body, which exploded and seeded the Earth with its meteorites. And this discovery leads him to unravel the secret meaning of the Flood and the creation of man.

(NOTE: Acquired From Foreign Distributor. Significant Delays Are Possible.)

480 pages 7X10 hardcover black & white illustrations \$39.95

WHEN TIME BEGAN Zecharia Sitchin—The architects of Stonehenge, says Sitchin, came to Earth thousands of years ago to usher in mankind's first New Age of scientific growth and spiritual enlightenment.

Paperback, 410 pgs., black & white illustrations \$6.99

the ATLANTIS RISING Catalog

10% Discount on orders of over \$100 (See page 81)

HARD-TO-GET VIDEOS

CLASH OF THE GENIUSES: INVENTING THE IMPOSSIBLE

Here, at last, is the story of a handful of inventors battling to save the world from industrial giants, like Ford, Morgan, Edison and their ilk. From Nikola Tesla to T. Henry Moray. From John Keely to Pons and Fleischman, the struggle to break through with world-saving technologies has gone on for generations, but now a new breed of inventors threatens to succeed where others have failed. Here is the story and the commentary of the geniuses behind many of today's amazing discoveries in free energy, anti gravity, rejuvenation, and much more.

One-Hour VHS \$19.95

ENGLISH SACRED SITES: THE ATLANTIS CONNECTION

Powerful evidence linking Stonehenge, Avebury, Glastonbury and many other English locations with an advanced ancient order now lost to history. Written and narrated by Atlantis Rising editor Doug Kenyon, the video is based primarily upon the discoveries of Cambridge-trained scholar and author John Michell. The program demonstrates how a mysterious network of perfectly



straight tracks, laid out for hundreds of miles across the English landscape, proves the great advancement of pre-historic science.

Forty minutes VHS \$19.95

TECHNOLOGIES OF THE GODS

Overwhelming evidence of the existence of high technology in prehistoric times, this video shatters the orthodox scenario for the dawn of civilization on Earth. Now assembled in a devastating one-hour documentary, hosted by Atlantis Rising Editor and Publisher J. Douglas Kenyon, are the comments and evidence of breakthrough researchers such as John Anthony West, Robert Bauval, Richard Noone, Colin Wilson, John Michell, Patrick Flanagan, Christopher Dunn, Zecharia Sitchin, David Hatcher Childress, Edgar Evans Cayce and others.

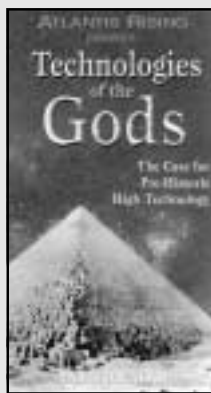

One-Hour VHS \$19.95

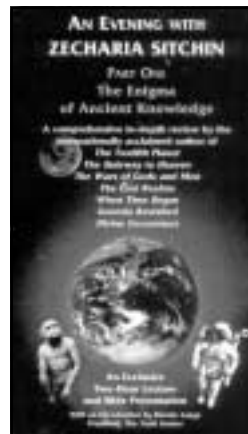

EVENING WITH ZECHARIA SITCHIN

Zecharia Sitchin, internationally acclaimed author of *The Twelfth Planet*, *The Stairway To Heaven* and *Genesis Revisited* to name a few, presents evidence for mankind's extraterrestrial origins and cosmic connections. Sitchin discusses some of the advanced knowledge possessed by the Sumerians nearly 6,000 years ago. Not only did they have the wheel and detailed writings on clay tablets but also wrote of the planets in our solar system and knew the accurate distances between them.

2-hours 2-videos \$34.95

GEOMETRIC METAPHORS OF LIFE In 1968 physicist Stan Tenen noticed a pattern in the Hebrew Text of Genesis. It took ten years for him to discover how the sequence of letters in the first verse of Genesis mathematically folds itself up into a fundamental three dimensional geometric shape whose shadows generate the alphabet in which the text is written. The implications of this work elaborated since then link consciousness with cosmology through geometric meditations expressed in gestures of our own hands.

2 hours VHS Video \$33.00

HOLES IN HEAVEN? Narrated By Martin Sheen—A Documentary on HAARP & Advances in Tesla Technology Starting with Nikola Tesla's inventions, this video features interviews with HAARP expert Robert Eastlund, and shows how the military plans to use this giant facility located at Gakona, Alaska to focus a billion-watt pulsed radio beam into the ionosphere. This will give us various capabilities, including "seeing" inside the earth, communicating with satellites and more.

51 minutes VHS Video \$29.95

JOURNEY INTO LIGHT

Part science, part art and part spiritual journey. Award winning photographer and film maker Gene Falk takes the viewer on a visual voyage into the heart of the crystal world. Crystals have a special history and have always generated great curiosity among scientists due to their unique qualities and ability to focus energy. Utilizing advances in optical technology, a special set of lenses once used for viewing outer space have been configured to explore the inner space of crystals with radiant beams, gleaming facades, fractured fissures and expansive auroras of a primitive world encapsulated for eons. A truly unforgettable experience you will never forget—a cinematic voyage into the mystery, magic and miracles of the crystal world.

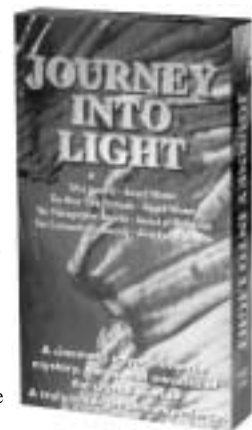

30 min. VHS \$19.95

USE YOUR CREDIT CARD (VISA, MC OR AMEX) AND CALL 800-228-8381 NOW

THE LEGEND OF ATLANTIS SERIES

THE DAWN OF THE GODS—Part One

The legend tells how thousands of years ago the Gods arrived on Earth from the stars in order to instigate the genesis of the human race. Human civilization developed and reached its peak at the time of Atlantis. A dark era was initiated and a war of the Gods lead to the sinking of Atlantis. A secret brotherhood brought the Atlantean knowledge to safety in Egypt and elsewhere. The secret Atlantean Brotherhood together with inspiration from extra-terrestrial guardians has used its educational programs to influence all our political systems.



85 minutes VHS \$24.95

THE SECRET BROTHERHOOD—Part Two

After the destruction of Atlantis the nations were divided. Parts of the Atlantean Brotherhood survived in Egypt, India and in Tibet. The Freemasons, the Templars and the Illuminati Brotherhoods all emerged from this original brotherhood. This is the first documentation of its kind to reveal the true origins of the secret brotherhoods and their belief structures.



85 minutes VHS \$24.95

SECRET PROPHECIES OF THE APOCALYPSE—Part Three

The prophecies of Nostradamus, the Mayan calendar, the writing in the great pyramid of Giza, and the recent changes on the Earth indicate that today's humanity has reached another cycle of evolution. This poignant documentary tells us about the last warning of Elia the returned prophet and his message for our times.



85 minutes VHS \$24.95

THE RETURN OF THE LIGHT-MASTER—Part Four

Thousands of years have passed since the high civilization of Atlantis. All the ancient people who lived through the decline of this dark era are being reborn today. This thrilling documentation shows why all the environmentalists, therapists, artists, esoteric teachers and many more are entering the Earth in order to heal it.



85 minutes VHS \$24.95

THE BATTLE OF ARMAGEDDON—Part Five

In this thrilling video documentation, the ancient secret of the pyramids, the Sphinx, the world network of tunnels under the Earth, the expedition of the Nazis to the South Pole and a lot more give the spectator an overview of the lost secrets of the past. It also discusses the great changes which will come on Earth.



85 minutes VHS \$24.95

SERIES SPECIAL - \$99.95

CONSPIRACY X: Government Secrets Revealed

Former Military Personnel, Frank Kaufman, Clifford Stone and Robert Dean, break their sworn oath of secrecy to expose the truth about the greatest UFO cover-up in history. After more than half a century of suspense, finally there is proof of a conspiracy at Roswell. Conclusive evidence from first-hand eye-witnesses who are speaking out for the record. This astonishing new documentary presents a straight forward argument from those who were there. Not hedged, not compromised, but simply what they believe and why they believe it. Without a doubt, this is why and how it really happened. The startling facts behind the legendary Roswell Incident.



1 hour VHS \$19.95

CONSPIRACY THE SECRET HISTORY EXPOSING HISTORY'S GREAT UNTOLD STORIES

Join an undercover team of investigative journalists as they take on today's managed news in an explosive series on the biggest cover-ups and conspiracies of our time.

Tape 1: Master of the Universe - The Secret Birth of the Federal Reserve

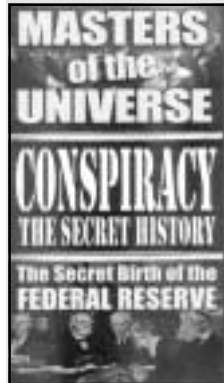

Reserve

Was there a takeover of the United States by international bankers? In this program you will visit the scene of a crime so perfect that, for thirty years, no one knew it had even taken place. Join us as we investigate the birth of a criminal conspiracy to rob each and every bank vault in America, all at the same time. This is the true, behind the scenes, story of the birth of the United States Federal Reserve.

50 min. VHS \$19.95

Tape 2: The Secret Heart Beat of America - The C.I.A. & Drugs

150 Min. VHS \$29.95

Tape 3: In Search of The American Drug Lords

50 Min. VHS \$19.95

3 Pack Set—260 Min. VHS—\$59.95

FREE ENERGY & ANTIGRAVITY PROPULSION

Tom Valone—Author of two books on the subject, Valone's captivating style will astound you with the truth about electrogravitics, inertial propulsion, free energy, magnetic motors, N-machines, the Searle effect, the Hutchinson effect, nuclear batteries and much more. Learn what these 21st century technologies will allow you to do. See demonstrations of anti-gravity and inertial propulsion that defies explanation. Become an expert on the new realities of free energy.

90 Min. VHS \$24.95

MIRACLE IN THE VOID Dr. Brian O'Leary—In this inspired presentation before an enthusiastic audience, Dr. Brian O'Leary presents the latest evidence for the birth of a new science of consciousness, which can offer solutions to the ravages of pollution. At center stage is his report on the remarkable research for clean, cheap energy to replace fossil fuels, which could reverse abnormal changes in our climate.

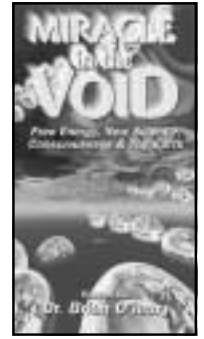

110 Min. VHS \$24.95

MONUMENTS TO LIFE: 2-PAK With Graham Hancock And Robert Bauval—*The Hidden Secrets of Mankind's Past Revealed and Lost Civilizations*—Covers the mysteries of the alignments of the three pyramids in Egypt with the constellation of Orion. Exciting and topical.

150 minutes 2 tape set, VHS Video \$29.95

MYSTERIES OF THE DEAD SEA SCROLLS EXPOSED

Frank Stranges—Dr. Stranges points out that there are currently 72 English translations of the Bible and that from the earliest days these translations were often incomplete, inaccurate or actually tampered with to change their meaning.

#1—72-minutes \$24.95

#2—40-minutes VHS \$19.95

MYSTERY OF THE SPHINX BC Video—The original NBC special (plus additional footage) which documented the case of John Anthony West and geologist Robert Schoch that, based on obvious rain weathering, the Great Sphinx of Egypt is thousands of years older than is maintained by orthodox Egyptology. Powerful and convincing arguments. The howls of protest haven't died down yet. West won an Emmy for research for work on this program.

95-minutes VHS \$29.95

NEW ENERGY SERIES

Tom Beardon

Beardon is the leading advocate of scalar potential electromagnetics and the Fogal charge-blocking semiconductor. He is also involved in alternate energy devices and scalar electromagnetic system prototypes. In this program, Mr. Beardon discusses zero point energy, Poynting energy flow, Tesla, Maxwell, scalar potential, quantum mechanics, hidden variable theory, our new challenges, the impact of a paradigm shift on today's science, back EMF, the virtual particle flux of the vacuum, Einstein's theories on general relativity, and other exotic topics in electrodynamics.



VHS 55 minutes \$29.95

Joseph Newman

VHS 55 minutes \$29.95

Dennis Lee

VHS 110 minutes \$29.95

Troy Reed

VHS 55 minutes \$29.95

John Hutchison

VHS 55 minutes \$29.95

New Energy Series Set of Five VHS Tapes \$119.95

USE OUR CONVENIENT ORDER BLANK ON PAGE 81

MORE GREAT VIDEOS ON THE NEXT PAGE

RODS—Mysterious Objects Among Us!

Cameraman and film-maker Jose Escamilla's bizarre journey in search of UFOs around us. He finds them around power lines and other places, appearing for a split second and then vanishing. He captures them with stop-motion photography and calls them RODS. Escamilla even uses some NASA footage to demonstrate RODS and gives instructions on taking your own videos.

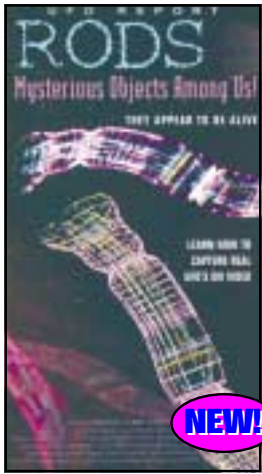

NEW!

VHS 60 Minutes \$19.95

SECRET OF NIKOLA TESLA—This is the rare Yugoslav-made feature film (in English) made 20 years ago. With Orson Wells as J.P. Morgan, the movie tells the story of the young genius as an immigrant to New York and his struggle to bring his fantastic inventions to the public, including his system of towers that would broadcast power into the atmosphere. A great movie on the suppression of technology and free energy!

110 minutes VHS Video \$29.95



THE SECRET NASA TRANSMISSIONS: 'The Smoking Gun' From

space shuttle cameras comes startling evidence that We Are Not Alone... On March 11, 2000, in front of an assembled audience of UFO enthusiasts and the media, evidence was presented that would appear to indicate the existence of not one, but two types of unknown extraterrestrial life forms. Labeled 'Phenomena One' and 'Phenomena Two' by a man who spent several years recording and logging thousands of hours of NASA space shuttle transmissions, this "historic" footage and the story that lay behind its discovery can now be revealed...

90 Min. VHS \$24.95

THROUGH THE EYES OF A CHILD—Awakening the Way of a Child Within Us
Drunvalo Melchizedek

In this two volume videotape set, Drunvalo Melchizedek presents the most up-to-date information available. With his awakened gift of synthesis, he discusses: Three New Races of Children, Conscious Water, The Bible Code, UFO's & Crop Circles. Experience the gifts of one of the new races of children, 18 year old Inge Bardor from Mexico, as she demonstrates her extraordinary abilities—capabilities that are latent in all of us.



VHS 2 tapes: Tape one 120 minutes
Tape two 95 minutes \$39.95

THE TRUTH ABOUT UFOs IN RUSSIA

An Italian television documentary (in English) about the epidemic of UFO sightings in Russia, including many daylight encounters. Italian journalist Giorgio Bonjiovanni interviews high ranking Russian Military officials and "former" KGB agents at the Russian Anti-Aircraft Academy of Defense in Tver, Russia who reveal "top secret" UFO files. Fascinating and rare footage of flying saucers, triangular craft and other UFOs from the Russian space program and Russian military.



NEW!

VHS 60 Minutes \$19.95



UFOs—50 Years of Denial?

—We've been told what happened 50 years ago... but what's happened since? Dr. Edgar Mitchell-Apollo 14 Astronaut and the man on the moon reveals that Roswell was a real incident and discusses the 50 year cover-up. Col. Philip J. Corso-Member of President Eisenhower's National Security Council and head of the U.S. Army's Foreign Technology Division at the Pentagon. "I had the evidence a crash did happen here..." Winner, 1997 EBE Award for Best UFO Documentary at the International UFO Congress.

60-min. VHS \$19.95

UFOs—The Secret Evidence—Researcher Michael Hesemann's video succeeds at covering contemporary phenomenon worldwide. Interviews with Col. Wendelle Stevens, Zecharia Sitchin, Bob Lazar, Robert Dean and others. Also incorporated is a rich body of which includes 44 authentic rare film clips of actual UFOs from around the world.

110-min. VHS \$29.95

UFOs—The Contacts—Since the 1950s people from all the world claim to have encountered visitors from outer space. This is their story. Contains interviews with eyewitnesses, investigations of their evidence and inquiries about their messages.

120-min. VHS \$29.95

WHAT HAPPENED ON THE MOON?

New evidence is presented to suggest the Apollo Mission pictures from the lunar surface were hoaxed by NASA.

VHS 222 minutes, 2 Tape Set \$49.95



NEW!

CD & CD ROM

THE ELECTRIC UNIVERSE

Wallace Thornhill—A startling vision of the physical world and the interactions of planets in earlier times, based on the surprising revelations of plasma physics. • The Sun as a stupendous ball of lightning • Venus' remarkable cometary tail • Lightning of the gods: violent scarring of planets and moons by electrical discharges • Laboratory proof of physical effects faster than the speed of light.

CD Rom Mac & Windows \$44.00



NEW!

LIFE ESSENCE SERIES—with Book, "Return to Harmony"

Created by Nicole Lavoie—Utilizes Sound Wave Energy technology that instills in sound frequencies specific nutrients for enhancing health and well-being. These CDs act much like a tuning fork, they remind our cells of their ideal vibratory rate, and the re-entrained cells will begin to match energy of the nutrients.

4 CD Set with book \$149.95

NOW AVAILABLE AGAIN



UFO ANTHOLOGY

Use your computer to dig for the truth about UFOs. For the first time ever, several of the world's most prominent and respected UFO researchers have come together to present this powerful, moving, compelling investigative exploration! Here is an interactive journey into the entire history of UFOs • Crop Circles • Alien Abduction • Government Coverup • Unexplained Animal Deaths. Also Included: An exclusive interview with Brig. General Thomas DuBose USAF, admitting on the record that the Roswell UFO crash balloon explanation was a cover-up!

Over 6 Hours On One CD-Rom!
(Windows or Mac). \$24.95

USE YOUR CREDIT CARD (VISA, MC OR AMEX) AND CALL 800-228-8381 NOW

ATLANTIS RISING Catalog

ORDER FORM

10% Discount on orders of over \$100

To subscribe or order any of the items on the seven preceding pages or on any of the house ads throughout the magazine (see directory) you have the following options:

- **TELEPHONE** Use your credit card and call our toll free number **800-228-8381**. (Mastercard, Visa, or American Express)
- **INTERNET** Use the shopping basket on our website at www.AtlantisRising.com
- **E-MAIL** Simply send a note to darsi@atlantisrising.com (be sure to include your Visa, MC or Amex number and expiration date).
- **POSTAL** Write **Atlantis Rising, P.O. Box 441, Livingston, MT 59047**, tell us what you want and include a check or money order in the correct amount, or use the handy form below. (Credit cards are also okay by mail, just include your number and expiration date).
- **FAX** Same procedure as with postal. Be sure to include your credit card information. Our fax number is **406-222-3078**.

MAKE COPIES OF THIS ORDER BLANK, SO THAT YOU CAN USE IT AGAIN!

ATLANTIS RISING HOUSE AD DIRECTORY

Advertising (classified)82
 Alternative science (books)50 & 55
 Back Issues5
Clash of the Geniuses (video)12
 Doctor's Best (supplements)44
 Earth Changes 2000 Tapes16
English Sacred Sites (video)22
 "I Am America" Prophetic Maps59
 Mailing Policies41
 Subscriptions8 & 67
 The Search for Lost Origins (book)38
 Subscriptions (foreign & 1st class)41
Technologies of the Gods (video)40

DATE PHONE

BILL TO:

First name Last name

Address

City St. Zip

SHIP TO (if different than bill to):

First name Last name

Address

City St. Zip

Qty	Item	Unit Price	Total

Deduct 10% when merchandise totals \$100 or more.
(offer does not apply to already discounted subscriptions or special sale items) →

Payment Method

Card #

Exp. Dt.

MERCHANDISE TOTAL	
SHIPPING & HANDLING	
ORDER TOTAL	
AMOUNT ENCLOSED	

All products sold by *Atlantis Rising* have a 30-day money-back guarantee against defects in materials and workmanship.

Products offered for sale by *Atlantis Rising* are made available in order to provide our customers with commercial choices difficult to obtain elsewhere. However, the appearance of any product in these pages, does not constitute an endorsement or guarantee by this publication. Any inaccuracies or invalid commentary in the contents, or problems with the quality of presentation, in any material offered are the sole responsibility of the producer of the material. Moreover, *Atlantis Rising* makes no claims or guarantees, express or implied, concerning the worth, appropriateness, or efficacy of any philosophies, remedies or strategies associated with any products sold or advertised in this magazine.

ALL ORDERS OF OVER \$100 (NOT COUNTING S&H) MAY DEDUCT 10% BEFORE ADDING S&H.
Shipping and handling charge is \$4.95 for the first item and \$2 for each additional item, unless ad states differently (i.e. all DR'S BEST, items ordered count as one item, page 44).
 Payment may be by enclosed check or money order, or by Visa, MC or Amex.

The Experience

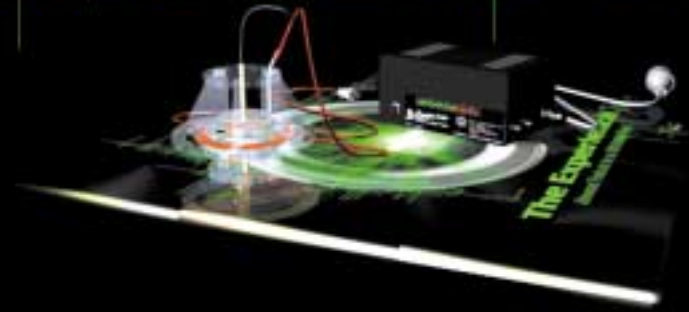

Q-Tech Laboratories from Australia has developed the most advanced Hydrotherapy Treatment on the planet. Founded by Terry Skrinjar, an amazing inventor who started designing highly advanced technology at five years old, Q-Tech has created the process unleashing the capacity for water to transform electric energy into Life Force Energy. By being in contact with the water during this process, your body is able to assimilate this Bio Energy and then utilize the energy as it sees fit. Once your body has the energy it needs to work with, its restoration/regeneration capacity is recovered. The results are astonishing! If you've seen the movie Cocoon, then you have an idea of the concept.

Advanced Products for an Advancing World

Many health practitioners have experienced the amazing benefits of this technology and have incorporated it into whatever healing modality they practice. Any technique is greatly enhanced when the body has the energy to operate properly.

Call Now

To receive an exciting information packet

888-249-6339

Experience

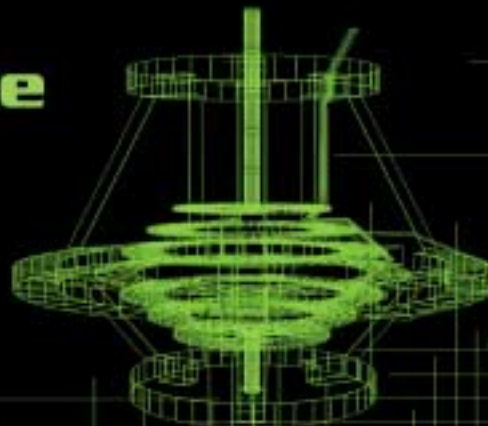

The Future

JUST ARRIVED FROM THE FUTURE



ELANRA THE WORLD'S ONLY PATENTED THERAPEUTIC IONISER

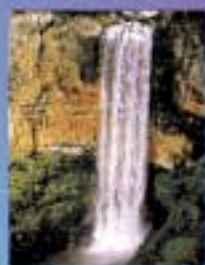

To gain the most from a negative ion generator it's important to understand that not all ion generators are the same. Ordinary ion generators produce large clusters of negative ions which cannot be inhaled and thus only serve to clean the air. Only ELANRA produces small

(ingestible) biologically active negative ions of oxygen – the same ions that are found in invigorating environments such as mountain tops, near waterfalls or on the seashore where waves break against rocks.

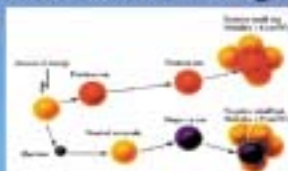

YEARS AHEAD OF ITS TIME

The result of 28 years of painstaking research, the ELANRA combines the best technology of all previous ionisers, together with a revolutionary microprocessor unit ensuring the correct production of ingestible negative oxygen ions. ELANRA is the only ioniser listed as a Therapeutic Device by the Australian Health Department, and has been wholly designed and manufactured in Australia.

“ ARE YOU SENSITIVE TO... ”

ASTHMA • HAY FEVER • RESPIRATORY BRONCHIAL SINUS • MIGRAINES • CHRONIC FATIGUE • SLEEP STRESS • CHEMICAL SENSITIVITY • IMMUNE SYSTEM ALLERGIES • CHEMO NAUSEA

SPECIFICALLY PROGRAMMED TO YOUR NEEDS

Much of the technology of today's artificial world has taken away the perfect “natural balance” of the air we breathe. ELANRA can restore that balance and, with a total 72 different programming structures available, can be specifically configured to your personal needs of ion output, concentration, frequency, direction and mobility. Ions travelling beyond the therapeutic range also rid the air of dust, smoke, pollens and other allergens.



For a list of therapeutic uses and complete details, contact:

ELANRA.COM, INC. - CALL TOLL FREE 866 466 4737 • WWW.ELANRA.COM
IONISER