

#66

November / December 2007

U.S. \$5.95 / Canada \$6.95

ATLANTIS RISING

Ancient Mysteries • Unexplained Anomalies • Future Science

Telepathy: What Does the Research Show?

ROBERT M. SCHOCH

Looks Where Other Scientists Dare Not

The Lost Library of Ivan the Great

STEVEN SORA

Tracks an Ancient Search Beneath Moscow Streets

Solar Cycles & Number 11

SUSAN B. MARTINEZ

On the Lost Secrets of Ancient Prophecy

H. G. Wells & Near-Death Experience

JOHN CHAMBERS

On What the Great Writer Really Knew

LOST CIVILIZATION
&
THE BERMUDA TRIANGLE

*Dr. Greg Little
On the Remarkable
New Discoveries
at Andros Island
and Elsewhere*



7 25274 88964 8



240 Pages \$21.95 + Shipping

THE DEAD ARE TALKING!

by Ross Hemsworth

90% of alleged paranormal occurrences, have logical and rational explanations, but the 10% that will not fit into that particular box, is what began my quest for answers.

My journey and quest for the truth has not been an easy one. Be warned - enter the world of paranormal research at your own risk - it can be fraught with danger, anguish, verbal and physical attacks from others and even an ear-battering from religious groups.

Ross Hemsworth, co-owner of Gastonbury Radio, is a well known paranormal presenter, scientific investigator of anomalous phenomena and an intriguing and entertaining speaker at events worldwide. His TV appearances include the hit series Ghost Detectives, the BBC's Ghostwatch Live - Tower of London and ITV's Haunted Halloween Live.

100 Spiritual Secrets

by Reginald G Johnson



100 Pages - \$11.95 + S&H

Read these powerful truths over and over again whenever you need to "recharge your spiritual battery" and come to the realization of your "true self," which is made in the image and likeness of God. Use them as guidance cards by closing your eyes and turning to any page to find answers to your unique questions. Each person is special, intelligent and is awaiting his or her majestic destiny, whatever it may be, to manifest. In time, it will. God bless you always in this life as you travel this special road.

Renowned speaker, author, intuitive and soul coach for the 21st century, Reggie Johnson helps people integrate their spiritual energy into their daily lives. Reggie's speaking is motivational and dynamic. The audience leaves with a new sense of purpose and the tools to tap into their own God-given power. They are reminded that the answers are within, and Johnson gives them the keys to creating opportunities, wealth, love and health through positive thinking and meditation.

The Hole in the Sky

by Brian J. Allen

In this exciting new book, the author, paranormal investigator Brian Allan, describes, analyses, interprets and compares many near identical anomalous phenomena, both in the UK and the USA, that could be interpreted as evidence that a 'hole in the sky' - a bizarre parting of the veil between the material world and the world of strange phenomena - exists, and also speculates on the conditions under which it might form.

The variety of unusual phenomena chronicled is impressive, but the author (who has personally investigated the cases and interviewed many of the experiencers) successfully guides us through the pitfalls of these exotic realms, revealing many fascinating possibilities along the way.

Brian J. Allen is the author of 2 additional books investigating the paranormal.



270 Pages \$22.95 + Shipping



\$19.95 + S&H

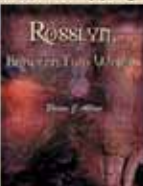

\$22.95 + S&H

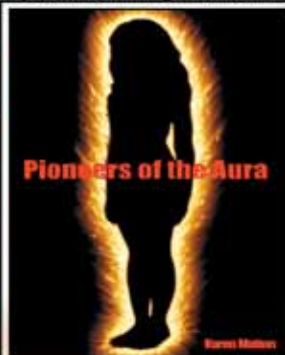

330 Pages \$22.95 + Shipping

Pioneers of the Aura

by Karen Mutton

I did not choose to write this book, it chose me. As neither a clairvoyant nor scientist, I had never considered writing a book about a scientific-metaphysical phenomenon. At the time I was making final revisions to my book 'T. Lobsang Rampa New Age Trailblazer' and working with the assumption that nobody was making any progress in aura research.

Investigations indicated that there were dozens of men and women who had studied and measured the aura, often encountering persecution and ridicule for their discoveries. It also became apparent that not only is aura research continuing today, but electronic devices which measure and photograph it have also been developed. These pioneers, whose discoveries should have revolutionised science, deserve to be acknowledged for their research and honoured for their amazing inventions.

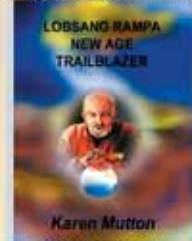

\$19.95 + S&H

HiddenMysteries.com

U.S. Shipping \$5.00 for 1st book add \$2.00 for each additional book International Please Email or Call

It's Here!
the
Rampa
Revival



\$12.95 + S&H

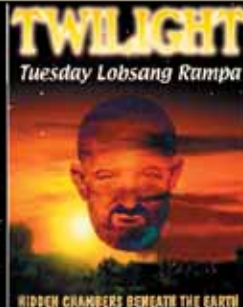

\$21.95 + S&H



\$21.95 each + Shipping

These treasured books, missing in action for too many years, are once again available from the authorized US publisher in large print! 8x10 size.

Phone 903-876-3256 or Order Online at <http://hiddenmysteries.com>

TGS Publishing, 22241 Pinedale Lane, Frankston, Texas 75763 Email: info@hiddenmysteries.com

ATLANTIS RISING®

CONTENTS

#66

November / December 2007

ANCIENT MYSTERIES
FUTURE SCIENCE
UNEXPLAINED ANOMALIES

PUBLISHER & EDITOR
J. Douglas Kenyon

CONTRIBUTORS

John Chambers
Michael Cremo
Julie Gillentine
Frank Joseph
Len Kasten
John Kettler
Greg Little
Cynthia Logan
Michael Lohr
Jeane Manning
Susan Martinez
Marsha Oaks
Robert M. Schoch
Steven Sora
Carly Svamvour

COVER ART
Ryan Hammer

GRAPHICS
Ryan Hammer
Randy Haragan
Denis Ouellette

ATLANTIS RISING®
published bi-monthly
Write PO Box 441,
Livingston, MT 59047
Copyright 2007
ATLANTIS RISING

No part of this publication
may be reproduced
without written permission
from the publisher.

ADVERTISING RATES
Please call 406-222-0875
or 800-228-8381
Send ad copy to
PO Box 441

Livingston, MT 59047
Publisher reserves right to
accept only advertising
deemed appropriate in sub-
ject matter & presentation.

DISTRIBUTION:
Newsstands,
subscriptions, mailings
& PDFs on the Internet
Subscription price
is \$24.95 (6 issues)



7 Letters

10 Early Rays

16 Report from
the Front

19 The Forbidden
Archaeologist

The Latest on the
Oldest Man

22 Confessions of
Lt. Haut

A Dead Roswell
Witness Steps Up

25 Getting at the
Truth

Stanton Friedman
Talks about What
the New
'Openness' Means

28 The Lost
Library of Ivan
the Great

32 Telepathy: a
Sympathy of
Souls

Robert Schoch on
the Early Research

35 Solar Cycles
and Number 11

39 The War for
Planet Earth

Part II on the
Intergalactic WWII

41 Thor's Hammer
in Quebec?

Tracking Canada's
Ancient Roots

42 Lost
Civilization and
the Bermuda
Triangle

New Discoveries
on Andros Island

44 Ken Eagle
Feather and
Dreams

46 H. G. Wells and
Near-Death
Experiences

Did the Great
Science Fiction
Writer Know More
Than He Said

48 Astrology
51 Video & DVD
57 Puzzle

Order BOOKS, DVDs & MORE: See Our Catalog on Page 74

CREATE PERFECT HEALTH TODAY
VIBRATIONAL ENERGY ELECTROMEDICINE
 ♥ CREATIVE HEALTH AT IT'S BREAKTHROUGH BEST ♥
 FOR ALL ISSUES OF EMOTIONAL, MENTAL AND PHYSICAL WELL BEING
DEPRESSION & ANXIETY
 BRAIN TUNERS
 Beyond the BT-6:
 Neuropulse I,II,III
 Dr. Bob Beck's
 BT-6 Pro \$250

INSOMNIA ADDICTIONS

Essential Photon Sound Beam Special \$995 Save \$200

ATP Inductor 2000 Ruby Gem Radiance

LifeForce Energy DNA Activation Sky David

Quantum Tissue Regeneration

ONE SOLUTION TO ALL PROBLEMS

Ultra Photon Sound Beam VIII \$1997

Rife/Lymph/Parasite Noble Gas

7 Universal Rife Frequencies, Variable Pulse, Sweep, RF Room Broadcaster, Sound Probe, 2 Noble Gas Applicators, 16 Upgrades

WE HAVE IT ALL
 Distributorships Easy

8000 Electromedical Series: Parasite Zapper, Silver/Gold Maker, Pulsers, Blood Purifier, E/M Field Protection for Body, Home & Office, Holographic Radionics, Chi Machines, BEFE, Light-Color Regenerative Technology

• RIFE/LYMPH/PARASITE NOBLE GAS TECHNOLOGY •
 FREE INFORMATION IHS, PO Box 817
 4 Excellent Cassettes Sedona AZ, 86339,
 50 Page Brochure \$10 City of Peace, (602)280-9069

www.jcau.com/energymedicine
 Serving You With Love since 1987

TIME MACHINES

For Catalog,
 Send \$1.00 US

Steven Gibbs
 PO Box 4
 Lyndon, KS 66451

www.hdrenterprises.net

ANCIENT MYSTERIES
UNEXPLAINED ANOMALIES
FUTURE SCIENCE

Visit
ATLANTISRISING.COM

A WORD FROM THE PUBLISHER

Challenging the Consensus

In 2005 Inner Traditions/Bear published *Forbidden History*, a collection of *Atlantis Rising* articles dealing with prehistoric technologies, extraterrestrial intervention and the suppressed origins of civilization. The book did so well—becoming one of the publisher's best-selling titles and already translated into several languages—that in 2006 we all decided to do it again.

With the publication of *Forbidden Religion* that spring, *Atlantis Rising* offered another collection of penetrating articles by some of the best writers in the business dealing with the suppressed heresies of the west. Once again the project was successful and like its predecessor soon appeared on the Inner Traditions best-seller list and was also translated into other languages. The inevitable question then became: what's next? We are happy to say that we can now answer that question definitively.

In the spring of 2008 Inner Traditions/Bear will be publishing *Forbidden Science*. From ancient technologies to free energy, the new volume will include the best of *Atlantis Rising* on the true story of science and technology, as suppressed by the orthodox scientific community and its collaborators in government and the media.

Forbidden Science will explore some of the less-traveled, even darkened, corridors beneath the shining edifice of academic science. In its pages you will find evidence that, no matter what the mandarins of the establishment would claim, the truth is not nearly so exemplary, or easily disposed of. You will learn of many controversial notions supposedly debunked by conventional argument, if, in fact, they have been discussed at all. But, from the true function of the Great Pyramid and the megaliths at Nabta Playa to Immanuel Velikovsky's astronomical insight; from zero point energy and cold fusion, to Rupert Sheldrake's research into telepathy and ESP, we think you will see that the facts are something quite different from what you may have been led to believe. And, if, in the end, you ask yourself, just why is such material excluded from consensus thought—indeed, why even its discussion has been virtually forbidden—then you are asking the same difficult questions as are the authors of *Forbidden Science*.

There is an organized war going on in science: materialistic (matter-based) theory versus anything that could be termed a belief system. Masaru Emoto's research into the energetics of water, for example, although supported by impressive photographic evidence, has been scoffed at by mainstream science because Emoto has dared to assert that humans affect their surroundings with their thoughts. The absolute rejection of such notions by the scientific establishment is, it can be argued, detrimental to true scientific inquiry, nevertheless, it serves, conveniently, to preserve funding for its own "safe" projects, those that will not rock the established hierarchy or the accepted official consensus. This book serves as a compelling introduction to the true history of alternative New Science research, the kind which takes orthodox science either as a mere starting point or as entirely wrongheaded from the outset. Forbidden or not, these new lines of scientific research themselves bar no path to the truth.

Contributors to *Forbidden Science* include the late Dr. Eugene Mallove, Jeane Manning, Dr. Robert Schoch, Walter Cruttenden, John Kettler, Cynthia Logan, David Lewis, Dr. Susan Martinez, even yours truly and many more. I do also, by the way, edit the book.

Containing 43 essays by 19 researchers, as well as scores of pictures (many in color) covering cutting-edge, heretical, or suppressed scientific research *Forbidden Science* will be essential reading for anyone fearing that today's scientific establishment has lost its way.

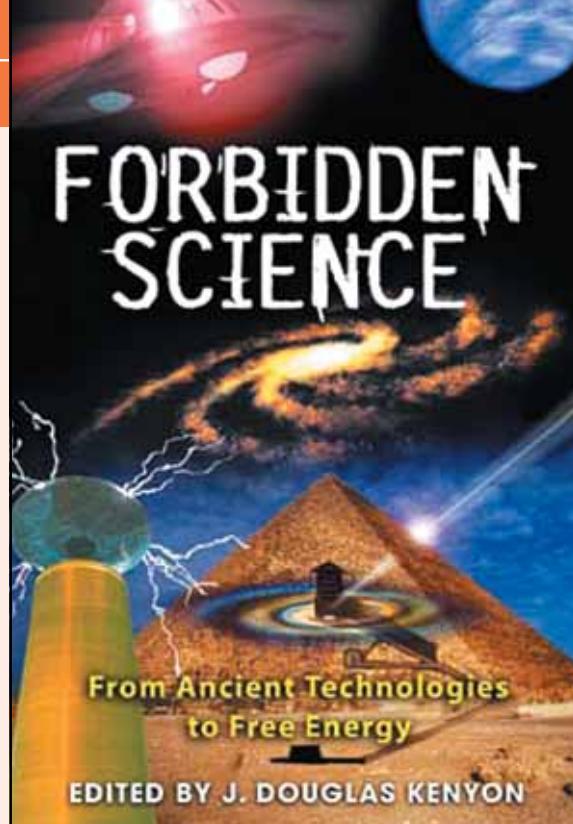

J. Douglas Kenyon
 Publisher

"Our Four Major Series will support you in expressing a life full of Joy, Happiness, Health, and the Healing of your Physical Body, Release Stress, give the Courage necessary to experience Prosperity, Clear Addictions, Release Fears, Doubt, Guilt and Resentments.



Nicole La Voie

The frequencies also help you to have more Clarity and Focus, a Greater Acceptance of yourself and others, Improve your Decision-Making Abilities, and Enhance your Spiritual Growth. I would like to invite you to call to get a copy of our latest Newsletter or visit us on-line to get the latest information on our products."

Each of the Four Major Series contains 12 CDs - \$288.00 each + Shipping & Handling

FOUNDATION	SPIRITUAL	MENTAL/EMOTIONAL	PHYSICAL AWARENESS
			
Chakra #1 Chakra #2 Chakra #3 Vol. 1 Chakra #3 Vol. 2 Chakra #4 Chakra #5 Chakra #6 Chakra #7 Love Relaxation & Calmness Higher Consciousness Brain, Courage, Prosperity	Thymus Transition Merkaba Energy, DNA, Enzymes Patience Oneness Purification Gateway Immortality Connections Shifting Consciousness Manifestation	Field of Light Purity of Blood Uplifted Communications Memory Emotion & Body Balance Addiction Awareness Confident Public Speaking Prana Dissolving Fears Gold, Platinum, Silver Home #1 Home #2	Higher Mind Pineal & Adrenal Pituitary Timeless Thyroid Parathyroid Plus Nervous System Pulmonary & Lymphatic Circulatory System Upper Digestive Lower Digestive Urinary System

Special Offer!

The Foundation Series plus 3 FREE CDs * ONLY \$288⁰⁰
& Nicole's Book, RETURN TO HARMONY

**your choice from 11 individuals.*

(+ \$11 S/H)

Not available in stores

"RETURN TO HARMONY"
 Autobiography of
 founder Nicole La Voie



3 FREE CDs!



CD's are nonrefundable.

THE FOUNDATION SERIES CONTAINS 12 CD's THAT:

- *Balance both sides of the brain.
- *Expand capacity for unconditional love.
- *Relieve stress, resistance, emotions (fear, anger, etc.).
- *Enhance sex, digestion, elimination, immunity, metabolism, etc.
- *Provide frequencies of nutrients for Chakra (glandular), balancing.

**SOUND
 WAVE ENERGY**

CALL AND ORDER TODAY!

888-267-2309/719-941-4949

www.harmonyera.com

Call for our Newsletter to receive the latest information on our New Products!

Are You Brushing Your Teeth with **POISON?**



Since 1997, the U.S. government has mandated toothpaste companies to print poison labels on their products! Are you brushing your teeth with poison? Just look at the back of the tube to find out. Even non-toxic toothpaste brands contain chalk and other abrasives that are unnecessarily harsh to your enamel and gums.

Why take chances? Try **Glacial Blue Tooth Oil** by Frequency Foods!
The **safest & most effective alternative** to toxic toothpaste!

Amazing Benefits of Glacial Blue Tooth Oil:

- Contains NO toxic chemicals or harsh abrasives.
- Proven formula with over 10 years of successful results.
- Proprietary blend of great-tasting peppermint, spearmint & almond oils - works long after brushing and keeps breath fresh for hours.
- Powerful healing properties nourish and support teeth and gums - helps eliminate cavities, remove plaque and stop painful tooth caries.
- Natural anti-bacterial action fights bleeding gums, gingivitis & gum disease.
- *Atlantis Rising* Readers: **Try Glacial Blue for only \$24.95 + FREE shipping!**

*"I love Glacial Blue Tooth Oil!
After just 3 weeks on the product,
my dentist said my diseased gums
were much improved and I had
half my normal plaque deposits!"*

J. Humburg - Grass Valley, CA

- **FREE Shipping**
- **60-Day Money Back Guarantee**
- **Incredible Retailer Program**
(Stores & Healthcare Professionals)

Order Today: Toll-Free 1-888-483-2283
Order online 24 hours a day at www.GlacialBlue.com

These statements have not been evaluated by the Food and Drug Administration. This product is not intended to diagnose, treat, cure, or prevent any disease.

This Space...

Could Be Yours!

ADVERTISE IN ATLANTIS RISING

You'll be seen nationwide, on
the worldwide web, and beyond...

Affordable **Call 800-228-8381** Visa/MC/Discover

"I now Manifest more Powerfully than ever before."

— Richard Gerber M.D.,
Vibrational Medicine

"Now that I'm wearing the e.Pendant, I've experienced full days without a single stressful or negative thought. The debilitating effects of daily beatings by a drunken father are gone. I can never thank you enough." — D. B., CA

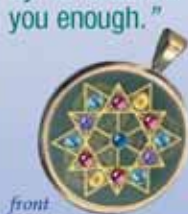

SACRED
GEOMETRIC
TOOLS



100% GUARANTEED
to be your most powerful energy tool

Order **NOW** to receive **15% OFF** all e.Pendants
and Geometric forms and get a **FREE CD**
"The Secret Truths Behind Sacred Geometry"

Call 1-888-978-2737 • www.metaforms.net

"Metaforms are extraordinary tools that enhance health and inner awareness." — Carolyn Myss, author

increase libido
improve stamina
promote well being

100% New Zealand source
standardized IGF-1
velvet antler

Blue Dragon

B R A N D



www.velvetantlerfactor.com

518.284.2203

Unveiling the Future

Writing to *Atlantis Rising*, via snail mail or e-mail is the best, but not the only way to make your views known to our readers. There are also "forums" on the *Atlantis Rising* web site (go to www.AtlantisRising.com and select "Discussions").

Seeing the Future

Very interesting article ("Can We See the Future," *A.R.* #65) and good to see more work being done on scientific proof of the ability to see the future. Your readers may be interested to know that some scientists are coming to believe that all sorts of "paranormal" phenomena, such as remote viewing, precognition, and distance healing, come about through the existence of what may be called "the information plane," as opposed to the "energy plane" in which we appear to exist. Russell Targ, a physicist by training, who has written books on remote viewing detailing his successful experiments in the 1970s (done at the behest of the government) that proved the existence of remote viewing ability in all of us, is one such scientist. He also, if I understand correctly, believes that the existence this "information plane" (where all information, past, present, and future is accessible at any time) may explain the phenomenon of how one can change the charge in one of a pair of photons and have the other one of the pair's charge change simultaneously, no matter how far apart the two parts of the pair may be separated. I further suspect that this "information plane" may also help explain Jung's Collective Unconscious.

One of the most fascinating examples cited by Dr. Targ of the ability to "see the future" exists as a long-out-of-print novel published in 1898 by a English writer named Morgan Robertson. It was called *The Wreck of the Titan*, and describes many of the major aspects of the incident of the sinking of the Titanic with eerie accuracy some 14 years before it happened! Robertson was alive in 1912, and would have clearly had full access

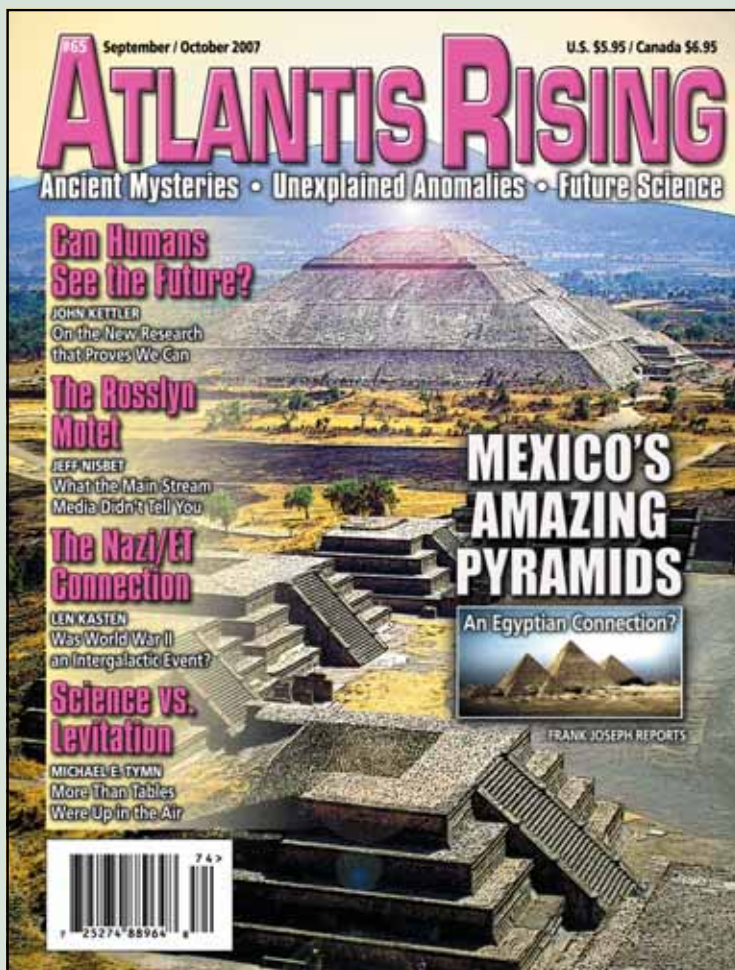

to the newspaper accounts of that incident. Dr. Targ believes that Robertson, searching for a topic about which to write a novel, simply unknowingly accessed his future memory. (Robertson also wrote a story about a war started by the Japanese attacking U.S. forces in Hawaii!) To this I can only add, from personal experience, that I (along with some 30 others who had never done remote viewing) spent a weekend last fall with Dr. Targ, studying our abilities to do remote viewing. The results were, even on the average for all of us, well above the levels of probability for random success, and sometimes amazingly accurate.

Bob Freedman
Internet

Consciousness can glimpse the future because those events have already happened as Idea, so their forthcoming reality is pre-

determined, thus "readable." However, ego denies fate's ordination and considers free will to be the essence of being. This delusion is key to ego's "rebellion" against the cosmic plan, being a dupe of evil trained to think indulgence and extremity are progress against so-called need.

Only by embracing fate can consciousness be "in tune" with the flow of time. That reality was firstly idea is positive because idea solved the questions of purpose and meaning with a flawless logic that enables everything which "proves" God is God. This everything "seems" to be a duality expressing good and evil, but enlightened consciousness sees beyond their common validity to the one resolution that makes appearances "worthwhile." This omega is eternity. Idea has designed the cosmos to achieve eternal judgment, and reality merely "follows through" with the plan.

It is not fate but ego which must be forsaken for truth to be understood. That fate is perfect and inviolate should be consoling, not threatening, because it means "everything" is important as a "piece of the puzzle." Yet ego

will no doubt try to manipulate time and "bend it to its will"; for as the pawns of evil, egos are vain and greedy, lacking the nobility and peace of mind to partake of God's nature as beings who "support" the bigger picture, eternity, and its inevitable success as the "real evidence" witnessed by all souls which shall forever supplant chaos and doubt with its divine testament.

B. J. Street
Paso Robles, CA

Cygnus Mystery

I read with great interest the article about *The Cygnus Mystery* by Andrew Collins ("Human Evolution and the Cygnus Constellation," *A.R.* #64). The information that the entryway to the Egyptian Hall of Records was discovered on the Giza Plateau was very exciting, but I was extremely dismayed that the article's author felt "this aspect is beyond the focus of this article!" Dr. >

OREGON BIGFOOT:

Search for a Living Legend
Volume I - DVD

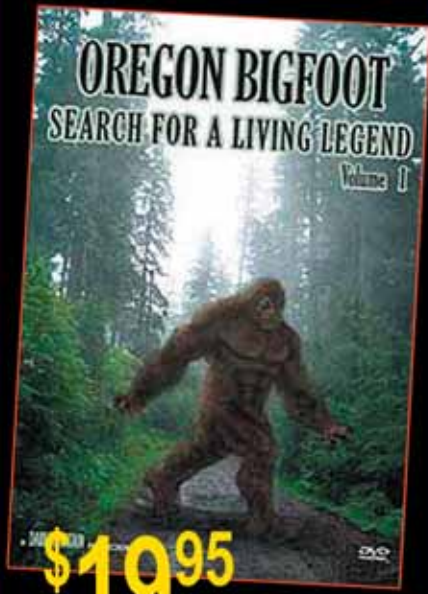

\$19⁹⁵
DVD

PLUS \$6⁹⁵ FEDEX GROUND

In the summer of 2005, a small team of researchers and a videographer, led by Autumn Williams, ventured into the remote Cascade Wilderness of Oregon... in search of a living legend. The Sasquatch research field has been dominated by men for over 50 years... it's time for a female researcher to take the lead. Be part of the adventure as Autumn and the team put innovative research techniques and technology to the test.

BONUS FEATURES INCLUDE:
"Women in Sasquatch Research"
Bloopers Reel
Technology and Gear Video
Approximately 113 minutes
Region 1 (US and Canada only)

theUFOstore.com
1930 Ash Street
Baker City, OR 97814

Order by Phone
541-523-2630



CHECK OR MONEY ORDER ACCEPTED

Continued from Page 7

Greg Little, is it possible to find out more about this discovery of the ages? Or can anyone enlighten me about what's happening at Giza concerning this important find?

There was an "Early Ray" tidbit that talked about giant gypsum crystals found in Mexico. The article indicates that crystals were used in early radios, but neglects to mention that those crystals were made of quartz, much different than the ones in Mexico. Still the discovery of 30' crystals of any mineral is pretty amazing!

Another "Ray": The Vatican "Angel" appears to be more like a fairy than an angel. Angels are creatures of indeterminant gender, while the figure in the photo has definite feminine breasts. Fairies, on the other hand, can be of any gender, but are usually only seen at night. So I figure the strong ray of light made the being visible in the dark Vatican. Either way, it's a comforting photo.

*David Paulsen
Keauu, HI*

Challenging Darwin

That remark, "Survival of the Fakest," ("Scientists Challenge Darwin," *A.R.* #65) is a joke! Indeed! When I was in the science class at Michigan State University in the 1950s, the professor simply divided the class in two halves and assigned my half to defend religion and the other half to defend the science of evolution. Then he puttered around his desk, as if waiting for us to debate those two issues. After one minute of no talk, he then said, "Well, if no one has anything to say on this, let's move on to the next subject. Page 42." And that was the end of it!!

*Moses Bernard
North Las Vegas, NV*

Paranormal Politics

I will tell you what makes it hard for paranormal investigators to seek out the truth. It is the fact that there are many hoaxers in the world. With this, there is a battle between the believers and the skeptics. This becomes Paranormal Politics.

Skeptics scoff at paranormal investigators and claim we are performing pseudoscience investigations. Every time I hold up a temperature gauge looking for cold spots, I feel like Carl Sagan, one of the leading skeptics, is frowning and shaking his head at me. Carl Sagan has every right to frown. The hoaxers of the world have ruined true scientific investigation of UFOs, ghosts and even the Loch Ness monster. Cryptozoology almost went out the door when they found out the most famous Loch Ness Monster photo was a fraud. There are tons of fake UFO photos, such as the infamous John T. Scopes UFO photo. Yeah, throw a Wok in the air, snap some photos and claim the ship came from Venus. We've all seen it all and hoaxers keep on hoaxing us.

Who were those two crazy old men in England stepping on sticks, walking around in circles creating their own crop circles? I just wonder how they create over a thousand elaborate mathematically in-tune crop circles around the world? They're almost like Santa Claus—they can be anywhere at once, creating crop circles. But, of course the media ignores that. Just because these two old guys took the glory of creating crop circles, we now believe that all crop circles were made by them. I know, another great skeptic Barry L. Beyerstein is probably shoulder-to-shoulder with Carl Sagan in heaven, looking down at me and saying... "we told you that crop circles were fake!" I look back up at Carl and Barry and say... "I bet you are saying that heaven is fake too!" But, it's good we have our skeptics, because some believers believe too hard. That is why I salute The Committee for Skeptical Inquiry that takes a critical look at the paranormal and any fringe science and disseminates the factual information for release to the public.

How many people remember how attorney William Weber confessed to the Amityville Horror hoax? With Weber, the motivation was money. How many people went and saw the Blair Witch Project movie, believing that the story was true? Yeah, they got you good. You spent your hard-earned dollars to watch a crummy homemade video movie and you bought into it. You were gullible and you were taken. My dad always said there was a fool born every day and there are a lot of fools out there.

Sure, many skeptics scoff at ghost hunters, but they must realize that there are many ghost hunting groups made up of skeptics. When all reasonable explanations are dispelled, you are left with one thing, the abnormal, the paranormal. I have been through many investigations and sure, I heard the EVPs, I saw the videos/pictures of orbs, white mist and so on. But, I wanted more. I wanted to hear something with my own ears, I wanted to be touched, I wanted to see something with my own eyes. After so many investigations, it happened, I was touched, I have seen a full body apparition. Am I a believer? Yes, I am and I still seek out the truth. If humans on the Quantum level are made of atoms, then we are true energy beings. So why can't ghosts exist—aren't they pure energy entities too? If we can maintain knowledge in our matter bodies, why can't we retain that knowledge in a more spiritual form? An aura surrounds our body at all times. Could that aura be our soul? When we die, could that aura be seen by others? Would they think that aura is a ghost? Seems pretty logical enough to me.

*Paul Dale Roberts
Internet*

Write to us at *Letters to the Editor, Atlantis Rising, P.O. Box 441, Livingston, MT 59047* or jdkenyon@atlantisrising.com



THE COVENANT PRINTS are demonstratively powerful, indicated by the dowsing rods' open position and the clockwise swing of the pendulum. The energetic reaction in humans is apparent to sensitive clients and practitioners.

We are in the end times—the end of our unconsciousness...

The idea for the Covenant Prints was given to me from the Creator. They are a tool to maintain our connection from our soul, to our cellular memory, to our seven energy centers (chakras) and our physical bodies, to the Creator. As that connection is realized, our thoughts become clearer, mind racing ceases, physical vitality is easily accessed, and most of all, we lose the fragmentation we experience in our dealings with everyday life. The Covenant Prints help us activate our light bodies. They hold the highest vibrational color frequency available in this dimension.

The Covenant Prints heal and release negative karmic records vibrating in our seven chakras, which trap sickness and disease in our bodies. They will re-awaken, reconnect, and reconstruct our matrix (divine blueprint) to its original pattern. The prints were designed to be simplistic in use. They require no special meditation or concentration.

Prints are laminated and remain clean and pure. I have been using the same set for years. They will always remain true to their purpose. Simply lie back for 5–10 minutes, and allow them to do their work. Each packet includes the seven prints, a laminated bookmark with an identical miniature version of each print, and an instruction booklet with their history and directions for use.

\$70.00 / set + shipping
To order (via PayPal)
send an e-mail to

ADivineCommune@aol.com



"I believe our spiritual path is custom made. However, our journey is the same. We are all looking to return home."

Savannah Morning Star
Chippewa Nation, Black River Tribe

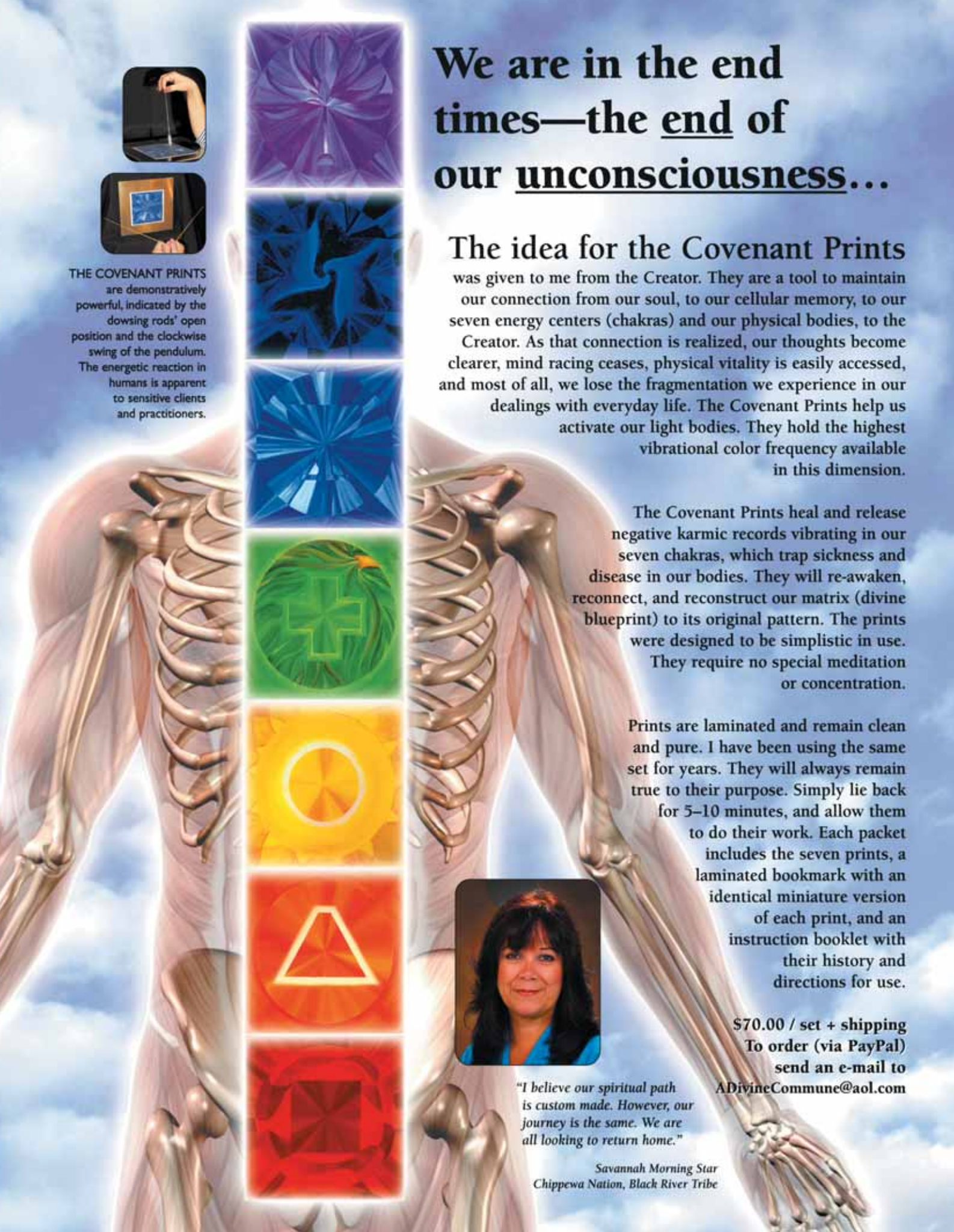

Don't Miss Out
on the
Adventure...

Subscribe to
**ATLANTIS
RISING**
today!

Share it with
a friend...Get a
2nd subscription
FREE!*

6 Issues (one year)
only **\$24.95**
30% OFF Newsstand price!

12 Issues (two years)
only **\$40.00**
43% OFF Newsstand price!

And **We Pay** Postage! **

Call **800-228-8381**



* WHEN YOU BUY ONE SUBSCRIPTION (EITHER 6 OR 12 ISSUES) WE'LL SEND YOUR FRIEND A SECOND SUBSCRIPTION FREE! MUST BE AT LEAST 100 MILES AWAY.

** SEE MAILING POLICIES FOR FIRST CLASS AND FOREIGN POSTAGE RATES.

EARLY RAYS

Alton Priors
formation

GIANT CROP CIRCLE APPEARS IN A FLASH

For crop circle aficionados eager to prove that the phenomenon is real and not just a concoction of hoaxers—such as the notorious Doug and Dave—there are few better opportunities than those which accompanied formation of the giant field design at Alton Priors, in Wiltshire, England on July 7 (7/7/07). Not only did the colossal pattern appear overnight but it did so while the entire area was under careful human and photographic observation. Even though the actual making of the intricate 1033-foot-long design of 150 perfect circles was not photographed, it appeared within a time window of no more than 105 minutes and was accompanied by a giant flash of light which caused a camera trained on the spot to stop functioning.

In a copyrighted story with photos and interviews on her earthfiles.com web site, reporter Linda Moulton Howe tells how student Gary King, his girlfriend Paula Presdee-Jones and filmmaker Winston Keech were drawn to the spot that night in hopes of catching circle-makers at work. Keech's light-sensitive cameras were optimized for low-light conditions and set to run continu-

ously. After determining that no crop circles, nor, in fact, any people were present, the three then became absorbed in conversation until interrupted by a great flash of light. At that moment, the tape from the infrared camera reveals what the observers believe was an electromagnetic pulse of some kind before going black. A few frames on the tape do catch some kind of energy spike. The other cameras unfortunately had run out of tape just before the flash, a fact which the group believes was known to whatever intelligence was behind the phenomenon. When next the three were able to observe the area an immense new crop circle had appeared.

The dramatic new pattern was one of the largest ever seen, covering 2.25 acres. Interestingly, the circles compensate for the uneven shape of the ground so that they are seen from the air as perfect circles, something which earthbound hoaxers would be hard pressed to accomplish with unlimited time, to say nothing of a little less than two hours. As with many other such sites, this one was accompanied with strong odors and other unusual sensations. ■

STAR DUST COMES TO LIFE

Nonorganic cosmic dust, when held in the form of a plasma, in zero gravity will spontaneously form into helical structures like those in DNA, which, as we know, have the power to reproduce themselves. That recent discovery has a panel of scientists from Germany's Max Planck Institute, the Russian academy of sciences, and the University of Sydney speculating about the possible spontaneous appearance of alien life forms unlike anything we know.

In a report published in the *New Journal of Physics* experiments on the International Space Station (ISS), 200 miles above the earth, are described which have produced such structures held together by electromagnetic forces which, it is thought, might have the power to reproduce themselves and ultimately to become intelligent, though not necessarily friendly, competition for life as we know it. The scientists are taking the results to be an indication that we should look

for life in forms far different than what we know. The American National Research council says we should start looking for "weird" life.

But, while materialistic science perceives such an unexpected appearance of order as leading to random development which might go scarily awry, many who see the principles of sacred geometry operating universally are unsurprised by the effects discovered in the ISS experiment. To them life, as we know it, represents an optimum—rather than random—development of the laws of proportion and harmony which guide the universe, and the great forcefields of the abyss display the same unifying principles as those in our little world. In other words, the evidence could be interpreted to mean that alien life, when we find it, may end up being more like what we know than what we don't, though there is certainly room for considerable variation. ■

Do Deep Space Photos Show Alien Engineering of Cosmic Proportions?

For the last four years, John Lenard Walson, an English musician and amateur astronomer living in Scotland, has been carrying his trusty 8-inch Meade telescope and a Sony camcorder to various sites in the U.K. and on the European continent in search of the best locations to photograph a series of strange structures which he has observed in space. To say that the 38-year-old Walson has produced some remarkable images would be an understatement. Clearly seen in regions of deep space are what appear to be gigantic and complex structures which seem to imply some kind of intelligent engineering.

Seen with extraordinary detail for indefinite periods of time are colorful, even beautiful, configurations apparently with elements of design which could signify a technological purpose of some kind. However, if indeed they have been engineered, the structures are built on a truly mind-boggling scale. Several of the objects photographed in the Ursa Major and Orion constellations appear to be located in fixed positions relative to the stars, meaning that they are in deep space. Others appear to be in "high space," not far beyond the orbit of our moon. In either case, the sheer scale—involving distances of millions of miles—is far beyond almost anything previously speculated, even by scientists willing to entertain the possibility of extraterrestrial intelligence. Among the few willing to consider such possibilities, though, is physicist Paul LaViolette. In his

book *Decoding the Message of the Pulsars*, Dr. LaViolette argues that pulsars may be engineered by advanced civilizations, and he speculates that a highly advanced interstellar society might be capable of engineering star-sized structures to control the electromagnetic and optical radiations of stars in order to create beacons for spacefaring navigation, if not more.

Just what is appearing to Walson's camera is not settled at this point. His photos have been examined by astronomers and photographic experts in both the U.S. and the U.K. and while mystified by the origin of his images they profess, at the least, admiration for his photographic skills and amazement at his results. Gerry Gilmore, an astronomer at Cambridge University in England, and Henry Klein, a photographic analyst at California's Jet Propulsion Laboratory, are among those who have congratulated Walson on his achievements in celestial photography. Others, it is claimed, have duplicated some of his shots, and, according to one unconfirmed report, the Cassini spacecraft photographed a structure near Mars which appears equivalent to one of Walson's images.

Interstellar, a forthcoming video produced by filmmaker Jose Escamilla, will present many of Walson's images to the curious public which can then decide for itself what to make of these striking pictures. To view the video on line go to <http://www.tbln.com/>. ■

Photos by John Lenard Walson



TIME MACHINE COULD BE POSSIBLE

Time travel could be possible, says an Israeli researcher. According to Professor Amos Ori of the Technion Institute of Technology, it all depends on whether spacetime is flat or curved. Ori has developed a new theoretical model of a time machine and his work has been published in the scientific journal *Physical Review*.

Time travel, says Ori, requires the space-time structure be engineered appropriately, which he says is what Einstein's theory of

general relativity meant. Space-time can be flat, he argues, in which case you can't leave your present position, or it can be curved with various configurations which would permit travel back in time. In such an arrangement you would be able to go back to an event in which you participated.

Whether the possibility of reliving events from one's own youth is sufficiently appealing to inspire further investigation remains to be seen. ■



CHINA WILL MAP THE MOON

The term "China Moon" may be about to take on an entirely new meaning—at least if the folks in Beijing get their way. China's National Space Administration has announced plans to map "every inch of the moon" and they don't plan on wasting any time in the process. What's the rush? As the British newspaper *The Register* put it, "There's Helium-3 in them thar hills."

The Chinese government believes that the moon will provide for earth's energy needs in the future. Though scarce on earth, the Isotope Helium-3 which is expected by many to be the fuel for future fusion energy production, is thought to be abundant on the moon. One shuttle load, it is said, could power the entire U.S. for a year.

China's announcement is but the most recent early signal of a rapidly accelerating race for energy resources which could make the gold rush of the 19th century look like kid stuff. Earlier this year, the Russians sent an underwater mission to the north pole to plant their flag and make a claim for oil which may some day may be retrievable from the polar regions. The Russians are also reported to be interested in lunar Helium-3 mining efforts.

China's new lunar mapping campaign will begin with the launch of an unmanned rover by the end of this year. Another unmanned mission is set for 2010 with the first manned mission planned for 2012, just five years from now. ■

EXOTIC MATERIALS MAY HOLD SECRETS OF THE MAGIC CARPET

Levitation, at least on the quantum level, could be getting off the ground. According to a report in *New Scientist Magazine* scientists are looking at several ways to achieve levitation, sometimes called anti-gravity, by using so-called metamaterials and the casimir effect. Metamaterials are those

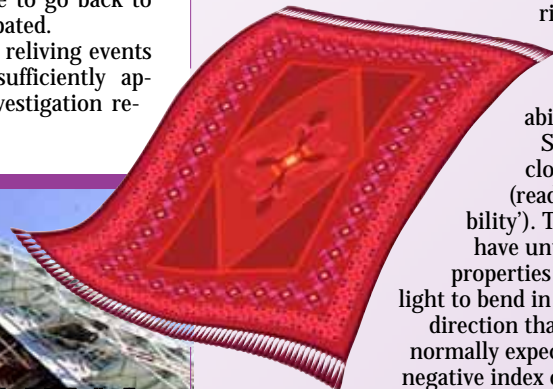

recently in the news for their

ability to create Star Trek-like cloaking effects (read that 'invisibility').

The materials have unusual optical properties which cause light to bend in the opposite direction than one would normally expect, creating a negative index of refraction, which can be set up so as to

make objects disappear.

Now several researchers have suggested ways to use those same materials in conjunction with the quantum fluctuations between casimir plates to achieve unusual repulsive effects. The attractive quality of the technique is that they would use less energy than magnets which can also levitate objects but, it is argued, only at great energy cost. A working device was manufactured last year. Ulf Leonhardt at St. Andrews University in the U.K., and John Pendry at Imperial college in London came up with the idea independently. And while the difficulty of producing metamaterials is a drawback, other researchers at the University of California, Riverside, and at North-West Technical University in St. Petersburg, Russia, have found ways to get around some of the difficulties.

Magic carpets using quantum fluctuations, though, still appear to be a good way off. In the meantime, the possibility of harnessing the powers of the mind to achieve the same result, as suggested by many esoteric traditions, remains unexplored, even ruled out, by conventional science. ■

PRG@paradigmresearchgroup.org
202-215-8344

X-Conference 2008 The Insiders - II April 18-20

X-Conference 2008 is being held during the US presidential primaries in order to draw attention to the candidate's refusal to speak to the most important issue of your time.

Speakers/Panelists, Banquet, Cocktail Party, Press Conference

Hilton Gaithersburg

Book Hotel Now

301-977-8900 (X-Conference)

X-Conference

www.x-conference.com

The False Prophets

Will the Year 2012 Bring Heaven or Hell?

This thrilling novel with esoteric, spiritual, occult, and political connotations, tells the story of a conspiracy to usurp an ancient Mayan prophecy from coming true in 2012.

The author, B.J. Boltauzer, is a Freemason, a Royal Arch Companion, and a member of a Masonic Rosicrucian College. He knows what he is writing about.

Check the web-site:
www.bjboltauzer.com

Order the book from:
AbeBooks.com • Amazon.com
or BarnesandNoble.com

Free Catalog baar.com 610-873-4591

Products for Health, Beauty, and Wellness

- Edgar Cayce Remedies
- Vibrational Energy
- Soaps & Cleansers
- Internal Cleansing
- Womens' Health
- Herbal Remedies
- Muscle & Joint
- Essential Oils
- Massage Oils
- Castor Oil
- Vitamins
- Hair Care
- Skin Care
- Anti-aging
- Pain Relief
- Oral Care
- Castor Oil



The Radiac®

(pronounced ray-dee-ack)

Impeccably designed to improve meditation, visualization, and spiritual development, refresh and realign your energy, harmonize the flow of life energy, and enhance your dreams.



Baar

Baar Products, Inc.
PO Box 60
Downingtown, PA 19335

Order Now
1-800-269-2502

www.baar.com

Mention you saw us in Atlantis Rising



Ancient Mesopotamian Relief

MESOPOTAMIA NOT 'CRADLE OF CIVILIZATION' AFTER ALL

It is almost official now, civilization started in places other than Mesopotamia. Indeed, according to the journal *Science* civilization had its beginnings in places as far away as India and Pakistan, not just in the so-called "cradle of civilization" Mesopotamia, also known as the fertile crescent, as is taught to every school child. According to reporter Andrew Lawler, "A radical new view of human civilization, extending far beyond Mesopotamia," has taken root and in July scientists gathered at a conference in Ravenna, Italy to discuss it. The agreed time of that origin, though, remains unchanged, about 5,000 years ago.

That mainstream science has now realized that the base of civilization should be spread over a larger area is only a baby step to those who believe there is clear and convincing evidence that our roots are even broader and deeper than the orthodox would

dare to imagine. Almost daily new discoveries falsify conventional theory: pyramids were being built in South America (Caral) as early as those in Egypt; the underwater (pre-diluvian) ruins of port cities are found near India (Dwarka) and in the Bahamas (see Greg Little's latest report on "Lost Civilization and the Bermuda Triangle" in this issue); the advanced knowledge of navigation and earth surveying in Britain (ley lines) and around the world (Piri Reis map) is millennia older than the so-called dawn of civilization etc. Never mind the geological dating of the Egypt's great Sphinx to at least seven thousand years ago—probably much earlier.

If history is any guide, though, the 'mainstream,' will, as it has done before, eventually find its way to 'discovering' the significance of much currently rejected evidence, which begs the question: where will the leading edge be by then? ■

FINAL ARROW TO THE HEART OF CLOVIS IS A COMET

For scientists still clinging to the notion that humans first appeared in the Americas about 12,000 years ago, these are hard times. Indeed their breed may be experiencing an extinction event of its own, as evidence continues to mount that the so-called Clovis model which once ruled American archaeology is rapidly going the way of the Piltdown man and other discredited ideas, into the dustheap.



Advanced arrowheads said to be the great Clovis achievement

As recently as the 1990s, to suggest humans could have been here before the Clovis horizon was academic suicide. Today, though, upcoming specials on the National Geographic Channel and PBS's *Nova* will focus on new evidence that a comet explosion around 13,000 years ago wiped out the mammoths and simultaneously virtually destroyed many of the so-called Clovis people at a time when science once believed they were on the rise and responsible for hunting the mammoths to extinction.

Also in the spotlight is the work of Dr. Al Goodyear whose excavations along South Carolina's Savannah river have turned up human artifacts dating up to 50,000 years ago. Maverick archaeologists like Louis Leakey and James Adavasio, who have long held that humans were here before Clovis, have gained a new credibility. Other investigators have taken a new look at the once famous Valsequillo site in Mexico where in the 1960s and 70s human artifacts were dated to as much as 300,000 years ago. The new research confirms the original dates. In the meantime, not far away Dr. Sylvia Gonzalez has turned up apparently human footprints in volcanic ash which could be even older than Valsequillo. ■



Dwarka explorer (NIOT photo)

THE SEARCH FOR ANCIENT DWARKA

According to Hindu legend the god Krishna built a city which was ultimately destroyed by rising sea levels. Now archaeologists and Indian Navy divers are investigating underwater ruins at Dwarka on India's western coast, said to be Krishna's city. The new efforts, it is hoped, will settle the debate currently raging over the age and authenticity of the site near the Samudranaraya temple. Divers have collected blocks and samples which will now be dated.

Traditional Hindu scholars referencing ancient Hindu scriptures believe the location to be very ancient, originally built many thousands of years ago. Such notions are, of course, vehemently rejected by establishment scientists though they are willing to concede that there is evidence indicating an age of as much as 3500 years. Of course the date when the city was destroyed would be long after the date of its inception, so a definitive maximum date has not been established. The new study is expected to resolve some of the issues.

Dwarka is among several coastal Indian sites now under investigation which show evidence of advanced development before sea levels reached their current height and thus provide significant evidence of pre-diluvian civilization—the existence of which is denied by conventional archaeology. ■

Reality
is what you make it

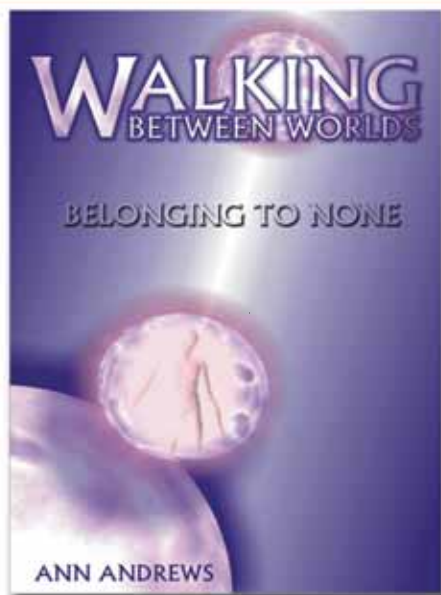

ISBN 0-9791750-3-8 19.95 usd

Walking Between Worlds Belonging to None

by Anne Andrews

This is the story of Jason, my Indigo child.... Ann Andrews came from a long line of abductees. Although it wasn't until her son's experiences accelerated that she began having dreams which enabled her to retrieve hidden memories, enabling her to accept and cope with what was going on with her son Jason.

What sets Jason apart from the many other "Indigo" children who are being born with exceptional multidimensional abilities is that Jason is not only an abductee, but is himself of Extraterrestrial origin.

The Coyote Oak

by Carlisle Bergquist

The Coyote Oak: Burgeoning Wisdom reveals what happens when dreams and reality collide. Just as a blue-silver ribbon of light peeks over the horizon above the Davidson's Kansas farm, they too, are about to find out. For James, a road-worn refugee from the music scene and his wife, Andrea, are struggling to find purpose by withdrawing to the country far away from their stressful corporate lives.

Spiritual insights they will learn, like the first light of dawn, often appear from the depths of darkness as this growth is woven from the threads of personal despair, willpower, and imagination.

"A fantastic adventure of a read"

- OH Krill

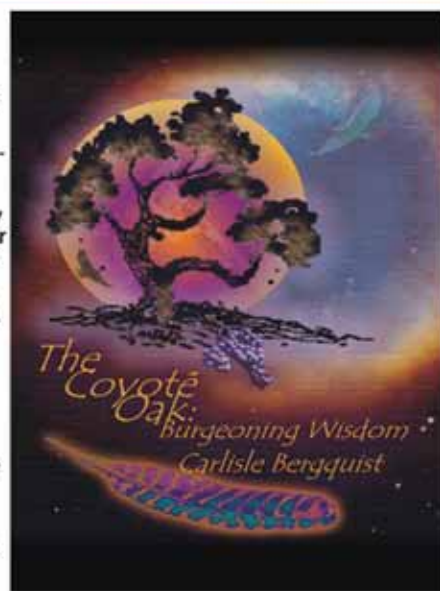

ISBN 0-9791750-6-2 19.95 usd

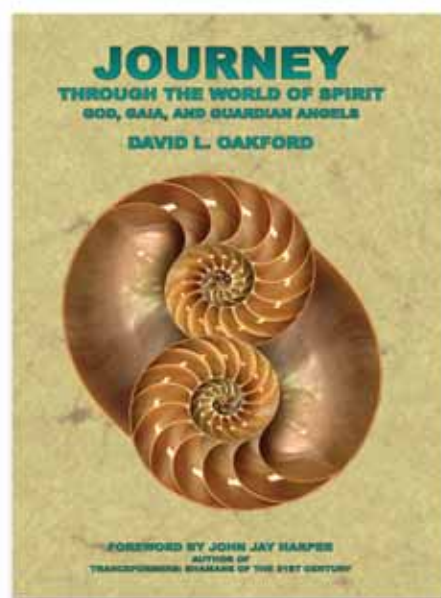

ISBN 0-9791750-9-7 17.95 usd

Journey Through The World of Spirit: God, Gaia, and Guardian Angels

by David Oakford

Initially triggered by a fatal overdose, this authors "NDE", Near-Death Experience was bewildering then turned frightening. He concluded we do not "die." Instinctively he knew to pray and was soon rescued by his own "guardian angel". The author shares his revelations concerning the life-after-death realms: heavens, light beings, dark souls, the life-force dynamics of our planet and the lessons learned from a panel of evaluators. His account of the life, death, and rebirth cycle reveals a truth that shines throughout this story.

9 Life Altering Lessons: Secrets of The Mystery Schools Unveiled

by Kala Ambrose

"Man, Know Thyself". In 9 Life Altering Lessons, Kala Ambrose of "Explore your Spirit" brings into modern light the ancient teachings from the esoteric mystery schools of Egypt and Greece. These schools still exist, and the teachings are available for those who seek to know themselves on a deeper level and desire to learn the deeper spiritual mysteries and secret knowledge. Kala, an esoteric teacher, shares nine of these mystical teachings, including how to explore the magical universe we live in, the secret power inside each of us and the destined journey of our souls.

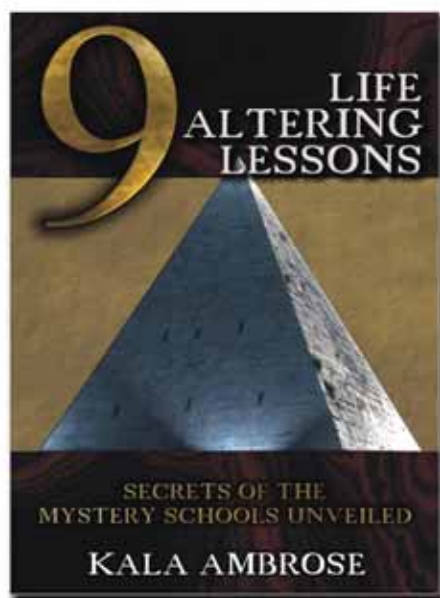

ISBN 1-934588-03-2 19.95 usd

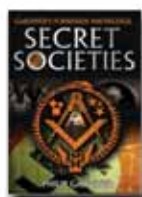

www.reality-entertainment.com
Reality Films and Reality Press are divisions of Reality Entertainment

All DVD and BOOK TITLES AVAILABLE at amazon.com.



TESLA AND OTIS CARR—TOO FAR OUT?

BY
JEANE
MANNING

An inventor whose reputation was ruined in the eyes of the 1950s public may yet be vindicated.

When you dig into history of either “free energy” or saucer-shaped spacecraft, you run across the name Otis T. Carr. He was forced to call his invention an “amusement device” in order to get a United States patent. At least one researcher had told me about seeing a working model of the Carr invention, but ironically I threw out the notes about those stories while downsizing file boxes in July to fit into a smaller living space.

Which brings us to the end of July 2007, the TeslaTech conference near Salt Lake City, Utah. One of the reasons I loaded my credit card to get there was the program list including people I hadn’t encountered in many years. And it said a speaker named Ralph Ring had worked closely with Otis Carr. An intriguing article by Dr. Michael E. Salla, about Carr and Ring, in a recent *Extraordinary Technology* magazine was titled “How the U.S. Government Suppressed the World’s First Civilian Spacecraft Industry.”

After talking with Ralph Ring and the friend who accompanied him to TeslaTech, I agree with Dr. Salla’s assessment and that of the web site ProjectCamelot (first to interview Ring). They conclude that Ring is 100 percent genuine, motivated simply to tell the truth about events of 50 years ago that could have revolutionized our lives.

Tesla as mentor

Ring starts his story with mention of inventor Nikola Tesla, who immersed himself in pristine natural surroundings during childhood as did Ring. During Tesla’s later years, Ring said, art student Otis T. Carr worked at the hotel where Tesla stayed, ran errands for the elderly genius and cherished their conversations. Since he was also a student of nature, Carr eagerly soaked up Tesla’s concepts.

Ring reminds us that Tesla told his financial backer J. P. Morgan about ubiquitous free power—anyone would have access to power broadcast through the earth by Tesla’s proposed system. Industrialists had other plans, vast grids of copper wires and related electric- and transportation monopolies. They feared Tesla would ruin the monetary system in which they made their fortunes. Tesla then realized the world wasn’t ready for the abundance he offered, even when he later had energy concepts more advanced

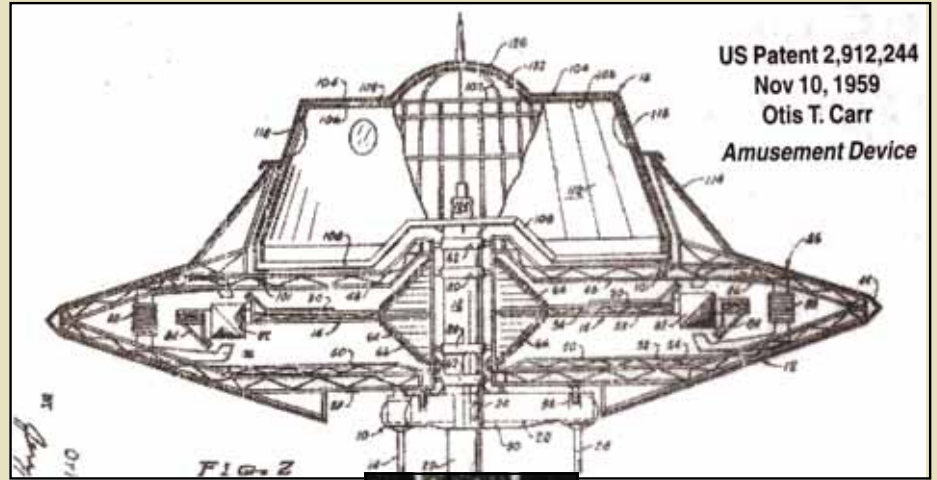

Otis Carr

than his broadcasting tower—smaller and more powerful systems. Tesla publicly said he knew how to build a revolutionary flying machine with neither wings nor propellers, powered by free electrical energy from the atmosphere. Blocked from realizing his dream in his era, perhaps Tesla did pass on secrets to his young student.

A few years after Tesla’s death, Carr began to build models of circular foil spacecraft that would store the free energy in special regenerative coils. By the mid 1950s he started OTC Enterprises Inc., based in Baltimore, Maryland. Radio legend Long John Nebel interviewed Carr, who said his models had been tested, airborne and one was lost in space. Major Wayne Aho, Carr’s chief pilot, vowed they would fly to the moon if given funding to build a 45-foot craft.

Then the public-relations disasters began. In April, 1959, a crowd of about 400 people waited for a scheduled test of Carr’s six-foot model in Oklahoma City. The test was cancelled and Carr didn’t show up. Nebel found him at a hospital where Carr spent eight days being treated for a sudden lung hemorrhage. He had no history of lung problems.

Fate Magazine published disgruntled comments such as that of an Oklahoma City television reporter who felt the announcement of a demonstration was just “ballyhoo” to publicize a saucer-shaped ride planned for an amusement park.

Ring says Carr’s troubles intensified with a mercury spill at his laboratory. When he decided to move operations farther West, his detractors accused him of looking for a fresh place to find investors. In California his life story intersects with Ring’s.

Ralph Ring meets Carr

Ralph Ring had always been fascinated by magnetism, as well as learning from nature about cause-and-effect, how bumblebees levitate and other wonders. After service in the U.S. Army, he started a successful scuba diving business. At his wife’s insistence he eventually applied for a safer job on land, and ended up as a technician in a large laboratory in California. An engineer had quit a magnetics project and Ring showed up at the right time.

Ring’s assignment was to apply strong jolts of electricity to see if an electron could travel across a polarized field without diverting to either the positive or negative side. The boss encouraged Ring to use plenty of electricity. But whenever Ring increased the power, the electron just slammed faster into the sides. As Ring understands it, the experiment was tied in with government interest in how to traverse powerful rivers of magnetism which flow in space.

He was soon bored with the repetitive task and concerned about taxpayers’ money it ate up. At the nearby work station, another employee’s task involved levitation of objects. That burned out electrical equipment hourly, costing at least twice as much as the task Ring was doing. Ring’s knowledge of how nature works led him to believe he could do both tasks differently—cheaply and easily.

Being a tinkerer, Ring owned some garage-sale test equipment. One night he took the cathode ray tube from the television and laid an oscilloscope, high speed Polaroid camera and other equipment on the living room floor. His wife retreated to the bedroom.

Continued on Page 58

NEW! The Ancient Bimini Harbor:

Uncovering the Great Bimini Hoax dvd

73-minute DVD documentary produced by Dr. Greg Little. In 1968 an underwater stone formation, dubbed the "Bimini Road," was found in shallow water off Bimini, Bahamas. Media reports hailed the formation as Atlantis and it seemed to confirm a prediction made by Edgar Cayce. But three skeptical geologists asserted that the formation was natural. In 2005 an expedition was made to Bimini by the ARE's *Search for Atlantis* team and archaeologist Bill Donato. The expedition discovered stone anchors, five stone circles, rectangular slabs under the massive blocks, and marble. Skeptical geologists were contacted with a stunning revelation emerging: a major hoax was perpetrated at Bimini and was traced to its source. Shows definitive proof that the Bimini Road was an ancient harbor. \$14.95; issued 2005.

Order from Amazon.com or Adventures Unlimited 1-815-253-6390

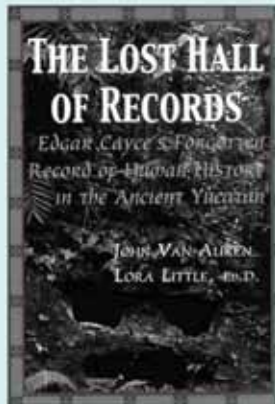
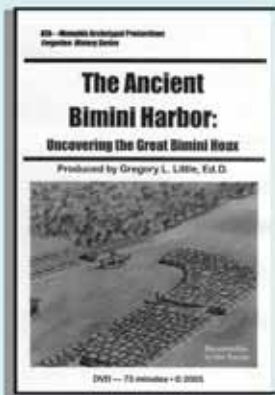

The Lost Hall of Records Edgar Cayce's Forgotten Record of Human History in the Yucatan

by John Van Auken & Lora Little. Edgar Cayce told of three Hall of Records established by Atlanteans just before 10,000 B.C. The location of the Yucatan Hall of Records is revealed with supporting evidence of Cayce's firestone. \$16.95 • Amazon # 0940829339 • 279 pages • heavily illustrated, index, published 2000.

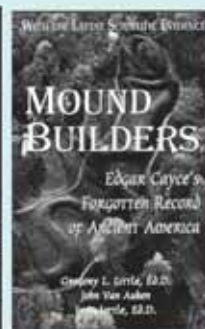

Mound Builders: Edgar Cayce's Forgotten Record of Ancient America

by Greg Little, John Van Auken, & Lora Little. Edgar Cayce gave 68 astonishingly accurate readings about ancient America and Mound Builders! \$16.95 • Amazon # 0940829363 • 294 pages • heavily illustrated, index, pub. 2001.

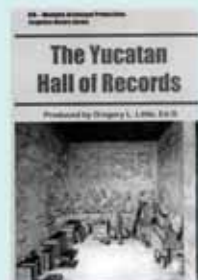

The Yucatan Hall of Records dvd

83-minute DVD produced by Dr. Greg Little detailing 2004 expeditions to Guatemala, Andros island, and Isla Cerritos in search of Atlantis and the Yucatan Hall of Records; featuring interviews with Andrew Collins. Contains never before released footage of incredible artifacts recovered at Piedras Negras. \$14.95 • Amazon # B00066N9YW

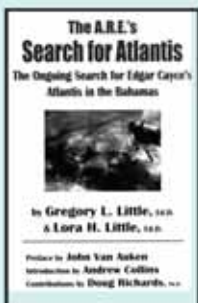

The ARE's Search for Atlantis: The Ongoing Search for Edgar Cayce's Atlantis in the Bahamas

by Greg & Lora Little with Andrew Collins, John Van Auken, and Doug Richards. Here is the story of the Bimini Road and other discoveries made in the Bahamas in the search for Cayce's Atlantis including the discovery of possible underwater breakwater at Andros in 2003. \$16.95 • Amazon # 0940829444 • 244 pages • heavily illustrated, index, pub. 2003.

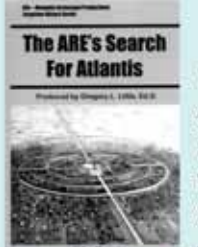

The ARE's Search for Atlantis dvd

73-minute DVD produced by Dr. Greg Little. Depicts the history of the Edgar Cayce organization's hunt for Atlantis in the Bahamas culminating in the discovery of an underwater stone platform off Andros island. Updated with 2004 expedition to Andros. \$14.95 • Amazon # B00066N9YM



Ancient South America

Recent evidence supporting Edgar Cayce's story of Atlantis and Mu—50,000-years ago. Lots of information packed into small book. \$8.95 • Amazon # 0940829355 • 108 pages, illustrated, index.

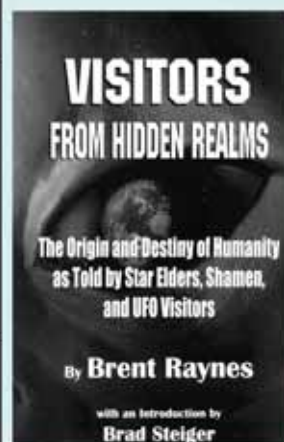

Visitors From Hidden Realms The Origin and Destiny of Humanity as Told by Star Elders, Shamen, and UFO Visitors

by Brent Raynes, Introduction by Brad Steiger. The culmination of 37 years of research by ufologist Brent Raynes. \$16.95 • Amazon # 094082938X • 182 pages, heavily illustrated, index, published 2004.

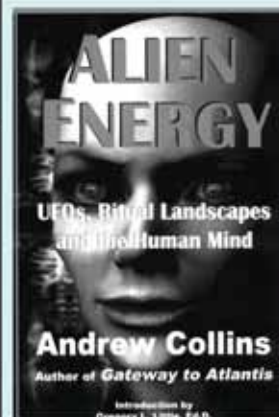

Alien Energy: UFOs, Ritual Landscapes and the Human Mind

by Andrew Collins, author of *Gateway to Atlantis*. USA reprint of classic 1994 examination of UFOs and crop circles by one of England's most respected authors. Reich, earthlights, and intelligent energy. \$21.95 • Amazon # 0940829371 • 248 pages, heavily illustrated, index.

Order from Amazon.com or Adventures Unlimited 1-815-253-6390

What if they were right?
 What if the afterlife was interactive?
 What if your desires had gravity?
 What if magic really worked?



Emmy award-winning host John Anthony West leads an unorthodox investigation into the convergence of modern science and ancient mysticism. In this ongoing documentary series, West is joined by a new generation of scientists, authors and researchers who are pioneering a radical new understanding of our past, present and future.

Magical Egypt

Director's Cut Re-release of the Cult DVD Series with new footage, new guests and new findings!

SAVE 35% ON ALL DVDS AND BOX SETS!

the new counterculture

forbidden history

mystery schools

sacred geometry

afterlife

unexplained technology

kundalini

occult sciences

8 x 1hr episodes



Ep 1: The Invisible Science - Is Egypt the birthplace of the occult? Mystery Schools sacred geometry, & the house of life at Karnak temple.



Ep 2: The Still Older Kingdom Is there a missing chapter in human history? West and Robert Schoch look at evidence of an earlier civilization.



Ep 3: Legacy Is the ancient stone calendar at Nabta Playa an alien artifact? Also, catastrophe theory and a discussion of the yuga cycle.



Ep 4: The Temple in Man - Onsite at Luxor temple, West discusses a lost key which decodes the ancient message encrypted in this mysterious temple.



Ep 5: What to do in the Duat. What if they were right? Rick Strassman & Lon Milo Duquette join West in an exploration of the science of afterlife.



Ep 6: Legacy What is the hidden thread that links ancient and modern magical practice? Plus, materia prima, alchemy and the philosopher stone.



Ep 7: Illumination A haunting look at Abu Simbel and a rare onsite segment by bestselling author Robert Bauval. Lon Duquette discusses talismanic theory.



Ep 8: Cosmology Is there a complex system of scientific notation hidden in the hieroglyphs? Laird Scranton presents amazing new discoveries.



produced by award-winning animator / art director **Chance Gardner**

This series is too controversial for television and is not available in stores. Call us toll-free:

1-800-853-6077

from outside the US call: **1 (306) 377-1496**

See our new website for episode writeups, new package prices, and for all the latest developments in the Battle of Realities.

www.magicalegypt.com

Single Episodes:

DVD \$ **24.95**

TRT 58min plus \$5.00 S&H

SAVE \$10 EA EPISODE!

Fanatic Pack:

NEW LOW PRICE!

get all 8 episodes for only **\$160.00** plus S&H

SAVE \$120.00!!!

The Forbidden Archaeologist



Notes from
Michael A. Cremonese

www.mcremo.com

Habs and Habs Nots

In the second week of August, my e-mail inbox started filling up with copies of newspaper articles, sent to me by my readers, about a new fossil find in Africa. Actually, one of the articles was sent to me by Doug Kenyon, the editor of *Atlantis Rising*. I took that as a hint he would like to see me devote a column to the story. So here goes.

Is the ancient apeman *Homo habilis* (let's call him Habs for short) a human ancestor or not? That is the question.

According to scientists connected with the recent fossil find in Africa, the answer to that question is no. That is quite something, because for a long time, we have seen Habs taking his proud place in the line of little ape men that get progressively bigger and more human-like in museum displays and textbooks all over the world. Probably those displays and textbook illustrations will remain uncorrected for a long time, but if the latest discovery is accepted, Habs no longer belongs in the direct line of human ancestors.

What exactly is this new discovery? In 2000 (as reported in the August 9 issue of *Nature*), Meave Leakey and some other researchers found an upper jaw of *Homo habilis* east of Lake Turkana in the Kenya. The jaw turned out to be about 1.44 million years old. The most recent *Homo habilis* bones previously discovered were 1.65 million years old. That fit in nicely with the idea that *Homo habilis* gave rise to *Homo erectus*, who gave rise to modern humans. According to most researchers, *Homo erectus* emerged in Africa about 1.8 million years ago. So the new discovery shows that *Homo habilis* and *Homo erectus* coexisted for almost almost half a million years. And in the *New York Times* (August 9), Meave Leakey says, "Their co-existence makes it unlikely that *Homo erectus* evolved from *Homo habilis*."

But if that is true, what about the whole theory of human evolution? Scientists were quite defensive about the new discovery, which tends to show that evolution is on shaky ground and is in danger of losing whatever public support it still enjoys (Gallup surveys have shown the vast majority of the American people do not accept the theory of evolution as it is taught by its scientific proponents). In an Associated Press report by Seth Borenstein (August 9), Susan Anton, an anthropologist at New York University, said she thought anti-evolutionists would be mistaken to seize on the admission that the evolutionary link between *Homo habilis* and *Homo erectus* no longer exists. I think not. Anton added, "This is not questioning the idea at all of evolution." Oh,



Meave Leakey



A popular depiction of *Homo habilis*, the ape man with his bone weapon, in Stanley Kubrick's 2001

Continued on Page 20

LATE-BREAKING STORIES
we're following on the Internet



Werner von Braun 'Saw Roswell Spacecraft' Says U.S. Astronaut

The scientist who led the development of Germany's devastating V2 rocket and later became a leading figure in the American space program, witnessed the Roswell "flying saucer" crash site and testified to seeing the bodies of its alien crew. That's the sensational claim being made by a NASA space shuttle team member, Clark C. McClelland.

<http://www.paranormalreview.com/News/tabid/59/newsid368/113/Famous-rocket-scientist-â€saw-Roswell-spacecraftâ€™/default.aspx>

Speed of Light Broken

A pair of German physicists claim to have broken the speed of light—an achievement that would undermine our entire understanding of space and time.

<http://www.telegraph.co.uk/earth/main.jhtml?xml=/earth/2007/08/16/scispeed116.xml>

Spooks in Space

What are the chances that an everyday object—a rock, a chair, you name it—could suddenly appear out of thin air? Not zero, surprisingly.

<http://www.newscientist.com/channel/fundamentals/mg19526171.100-spooks-in-space.html>

Continued on Page 20

• **Were Seafarers Living Here 16,000 Years Ago?**

In a Canadian archaeological project that could revolutionize our understanding of when and how humans first reached the New World, researchers in B.C. have begun probing an underwater site off the Queen Charlotte Islands for traces of a possible prehistoric camp on the shores of an ancient lake long since submerged by the Pacific Ocean.

<http://www.canada.com/victoriatimescolonist/news/story.html?id=34805893-6a53-46f5-a864-a96d53991051&k=39922>

• **Remains of Nebra Sky-Disc People Found in Germany**

Archaeologists digging at the place where an amazing Bronze Age disc was found have turned up a body and remains of a Stone Age building, adding to the riddle around one of the world's biggest archaeological sensations of the past decade.



Nebra Sky-Disc

<http://www.eux.tv/article.aspx?articleId=14001>

• **Modern Man Much Older than Previously Believed**

A Hamburg University professor has discovered huts and sedentary village life dating between an astonishing 400,000 and 200,000 years before the present—challenging the common understanding of man's evolution.

http://minervamagazine.com/news.asp?min_issue=JUL_AUG2007#0

The Forbidden Archaeologist

Continued from Page 18

yes it is, Susan. "It is refining some of the specific points." Oh sure. Removing one of the major links in the human evolutionary chain is just a "refining" of a specific point!

In a report from MSNBC.com (August 8), we find Bill Kimbel of the Institute for Human Origins at Arizona State University striking a similar note: "All the changes to human evolutionary thought should not be considered as a weakness in the theory of evolution, Kimbel said. Rather, those are the predictable results of getting more evidence, asking smarter questions, and forming better theories."

Well, let's look at the current state of affairs in human evolution. It is a huge mess. Some scientists think that modern humans arose once in Africa, and spread from there all over Eurasia, replacing all the other Neanderthals and *Homo erectus* populations already there. Another group of scientists says different groups of modern humans evolved separately from *Homo erectus* and the Neanderthals in different parts of the world, more or less simultaneously. Some scientists say that modern humans interbred with Neanderthals, and others say they did not. Some say that *Homo habilis* gave rise to *Homo erectus*, and now some say that *Homo habilis* did not give rise to *Homo erectus*. Going back further, some scientists say that *Australopithecus* gave rise to the genus *Homo*, and others suggest that another hominin, *Kenyanthropus platyops* (discovered by Meave Leakey) may have been the ancestor of *Homo*.

In light of this, let me suggest something. If as scientists working with a certain theory find as time goes on that new evidence results in further and further complications and contradictions, one might consider that there is something wrong with the basic theory that humans evolved from more primitive apelike ancestors. Scientists are finding as they discover more and more fossils that the evolutionary picture breaks down, and instead we find more and more examples of coexistence. Many scientists used to think humans evolved from Neanderthals. Now most of them believe humans coexisted with Neanderthals. Many believed that *Homo erectus* evolved in a linear way from *Homo habilis*. Now they are saying the evidence shows that *Homo habilis* and *Homo erectus* coexisted in the period from about 1 to 2 million years ago. The basic pattern that emerges is one of coexistence rather than evolution.

And if we really look at all the evidence, we find examples of fossils that show that humans like us coexisted in Africa with both *Homo habilis* and *Homo erectus*. In other words, *Homo habilis*, *Homo erectus*, and *Homo sapiens* were all coexisting. Let me give a few examples from my book *Forbidden Archaeology* (FA), in which you can find the detailed reports, complete with bibliographical references.

In the year 1914 the German scientist Hans Reck announced the discovery of a fairly complete human skeleton, of modern type, in Bed II of Olduvai Gorge (see FA, pp. 628-649). According to modern geologists, Bed II of Olduvai Gorge is from 1.15 to 1.7 million years old. This is within the age range for both *Homo habilis* and *Homo erectus*. Reck's original report says the skeleton was found solidly embedded in the rock of Bed II, with no sign of intrusion from some higher more recent level. The skeleton was taken to a museum in Germany. Most

Lake Turkana, Kenya



Continued on Facing Page

of the skeleton, except for the skull, was lost during bombing raids in World War II. In 1974, the German archaeologist Reiner Protsch published a radiocarbon age for a bone fragment he claimed was from the original skeleton. The age was about 16,000 years. There are three problems with this age: (1) it is not certain that the bone fragment really was from Reck's skeleton, (2) the method Protsch used did not adequately take into account the problem of contamination of the bone with recent carbon, which would cause the test to yield a falsely young age, and (3) a few years ago, Protsch was removed from his position at a German university after it was shown that he had falsified dozens of radiocarbon dates over the course of his career.



Homo Habilis

In 1973, Richard Leakey published a report about two femurs (thigh bones) found at Lake Turkana in Kenya. Richard Leakey said in the science journal *Nature* (1973, vol. 242, p. 450) that the thigh bones (the ER 1481 and 1472 femurs) "cannot be readily distinguished from from *H. sapiens* if one considers the range of variation known for this species." It was given an age of about 1.8 million years. In 1977, French researchers announced the discovery of a *humerus* (upper arm bone) at the Gombore site in Ethiopia. According to the report, the site was about the same age as lower Bed II at Olduvai Gorge (about 1.7 million years). This is within the date ranges of both *Homo habilis* and *Homo erectus*. B. Senut said in a paper published in the book *Primate Evolutionary Biology* (1981, p. 91) that the *Gombore humerus* "cannot be differentiated from a typical modern human."

Evidence for an anatomically modern human presence goes back even further in Africa. At Laetoli, in Tanzania, Mary Leakey found dozens of footprints arranged in three parallel tracks. In her original report, published in *National Geographic* (1979, vol. 155, p. 453) Mary Leakey said the footprints were "exactly the same as ours," an opinion later confirmed by other researchers such as footprint expert Louise M. Robbins and physical anthropologist Charles Oxnard. In 1967, Bryan Patterson and W. W. Howells announced the discovery of a *humerus* (upper arm bone) at the Kanapoi site in Kenya. The bone was found in Pliocene lake sediments about 4.5 million years old. In a report published in *Science* (1967, vol. 156, pp. 64-66), Patterson and Howells characterized the Kanapoi *humerus* as like that of a modern human being, a judgment later upheld by other researchers such as Henry M. McHenry and Robert S. Corruccini who said in a report published in *Folia Primatologica* (1975, vo. 23, p. 240) that "the Kanapoi humerus is barely distinguishable from modern Homo."

A final blow: There have always been some scientists who do not believe that *Homo habilis* deserves to exist as a taxonomic (hierarchically organized) species. For example, anthropologist C. Loring Brace said in a paper published in the book *Primate Ecology and Human Origins*, edited by I.S. Bernstein and E.O. Smith (1979): "*Homo habilis* is an empty taxon inadequately proposed and should be formally sunk." T. J. Robinson argued that *Homo habilis* derived from a mixture of skeletal elements belonging to *Australopithecus africanus* and *Homo erectus*, according to Bernard Wood (*Nature*, 1987, vol. 327, p. 187).

Poor Habs. Not only is he not a human ancestor, but he may not have existed at all. ■

Michael A. Cremonese is author, with Richard Thompson, of the underground classic Forbidden Archaeology: The Hidden History of the Human Race. His latest book is Human Devolution: A Vedic Alternative to Darwin's Theory (see www.humandevolution.com).

• **Old Star Shows Signs of Earthlike Planets**

Chemical elements observed around a burned-out star known as a white dwarf offer evidence that Earthlike planets once orbited it, suggesting that worlds like our own may not be rare in the cosmos.

<http://www.msnbc.msn.com/id/20306385/>

• **Colossal Tail Trails Dying Star**

A distant star that hurtles through space at extraordinary speeds has a huge, comet-like tail trailing in its wake—13 light years in length—astronomers say.

<http://news.bbc.co.uk/1/hi/sci/tech/6947607.stm>



• **Noah's Ark Anomaly Gets a New Image**

Three high-tech companies have joined the search for evidence that a 980-foot-long feature on Turkey's Mt. Ararat might be what's left of Noah's Ark.

http://news.xinhuanet.com/english/2007-09/03/content_6654942.htm

• **'Lunar Ark' Proposed in Case of Deadly Impact on Earth**

The moon should be developed as a sanctuary for civilization in case of a cataclysmic cosmic impact, according to an international team of experts.

<http://news.nationalgeographic.com/news/2007/08/070814-lunar-ark.html>

*A Previously
Unheard Account
from Beyond
the Grave
Reinvigorates the
Roswell Case*

The True Confessions of Lt. Haut

In June, the famous dispute over reports of a crashed UFO near Roswell, NM in 1947 got a new lease on life from a dead man. One important witness to those controversial events, whatever they were, had previously refused to talk, but now he has, from beyond the grave.

Lieutenant Walter Haut was the public relations officer at the Roswell Army Air base in 1947, and was the man who issued the original and subsequent press releases after the crash on the orders of the base commander.

Haut died almost two years ago, but left a sworn affidavit to be opened only after his death.

In the text released in June, Haut adds several details to the familiar story, including an assertion that the famous claim by the air force that the wreckage was merely a weather balloon was simply a cover story, and that the real object had been recovered by the military and stored in a hangar. Haut described seeing not just the craft, but alien bodies as well.

The affidavit has been the subject of considerable media attention, and researcher John Kettler has looked further into the case. Here is his report. ED.

• BY JOHN KETTLER

Haut's supposed "deathbed" affidavit turns out, despite the recent sensational coverage, to not be quite what it seems. In reality, the affidavit was sworn and notarized five years earlier and was held by his attorney with instructions to release it only upon his death.

Why it took two years more (Haut died in December 2005) is unknown, but his original stated goal was to fulfill a promise he had made to then Roswell Base Commander, Colonel William Blanchard, not to reveal certain highly sensitive experiences while Blanchard was still alive.

It would appear that Haut erred on the side of caution and waited until he himself had left the scene to set the record straight and to provide what had carefully been left unstated in his public affidavit. The differences are major and highly significant. Indeed, they add some explosive new angles to the familiar Roswell story. The confirmation of ET bodies at Roswell is hardly new. Haut's swearing he saw them personally, though, is. The real shocker is that Haut explicitly describes the famous press release he wrote, the one which caused a global sensation in July of 1947, as a deliberate diversion and

coverup of something much more important than ET craft wreckage strewn on Mac Brazel's ranch.

A Tale of Two Affidavits

According to Roswell researcher David Rudiak (<http://roswellproof.homestead.com/Haut.html>) here's what really happened. Not only did Haut have an expurgated and unexpurgated version of his affidavit, but he also spilled the beans earlier privately in 1989 to Robert Shirkey, Sr., a good friend and the former Assistant Operations Officer at Roswell (attested by his son, Robert Shirkey, Jr.; audio clip at site) and also gave a lengthy personal oral history in 2000 to researchers Wendy Connor and Dennis Balthausen, people he knew well and could absolutely rely upon to keep their promise not to release the interview until he died.

The 1993 Affidavit

If we dispense with the boilerplate, Walter Haut basically says five things: 1) While serving as the PIO, Col. Blanchard called him, informed him of the existence of the "flying saucer or parts thereof," origin, a ranch NW of Roswell, and that the Base Intelligence

Continued on Page 59

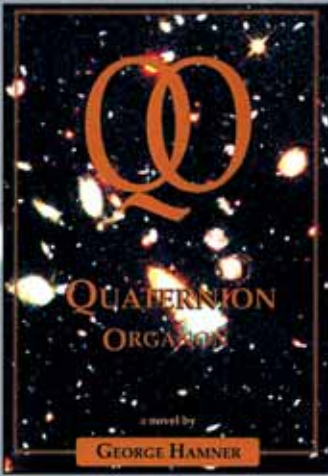

Looking for Hard Science to Match Your Mystical Beliefs?

Quaternion Organon, which roughly translates to "Four Systems of Thought," is one of the few works to cover the spectrum from advanced physics to metaphysical

theory. It also contains a story whose characters help the reader digest the difficult science. At over 400 pages, QO is not easy reading; however, those who tackle it are rewarded with keen insight into the workings of the universe.

Quaternion Organon ~ Author George Hamner

Published 2002 by Court Street Press ~ ISBN: 1-58838-040-8

Read reviews & order from **Amazon.com** & major booksellers.

For an autographed copy, email georgehamner@aol.com.

Only \$20 plus shipping.

Messages from the HOLLOW EARTH

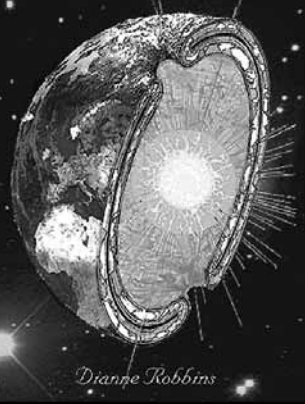

Messages from the HOLLOW EARTH

by Dianne Robbins

Not only is the Earth HOLLOW, but it is inhabited by Advanced Civilizations! Read the telepathic messages

from evolved civilizations that live in peace and harmony in the Center of our Earth, which is HOLLOW, and contains an Inner Central Sun, with oceans and mountains still in their pristine state.

Discover the Lost Library of Alexandria!

To order, send \$20 plus \$5 S/H to:

Box 10945

Rochester, NY 14610 USA

Call **585-442-4437**

Visit **www.DianneRobbins.com**

Seven fascinating books from:

Ralph Ellis

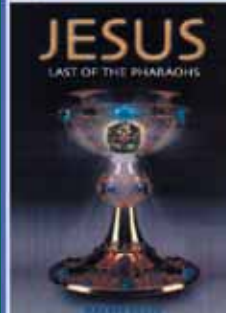

Jesus, Last of the Pharaohs

The biblical patriarchs were the Hyksos Shepherd pharaohs of Egypt.

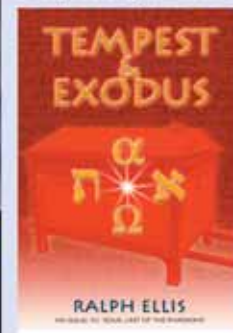

Tempest & Exodus

Mt Sinai was the Great Pyramid of Giza.

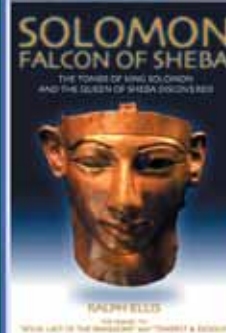

Solomon, Falcon of Sheba

Kings David and Solomon were pharaohs of Egypt.



Eden in Egypt

Adam and Eve were Akhenaton and Nefertiti.

Scota, Egyptian Queen of the Scots
Ireland and Scotland were founded by an Egyptian queen.



Cleopatra to Christ

Jesus was the great grandson of Queen Cleopatra.

(double book)

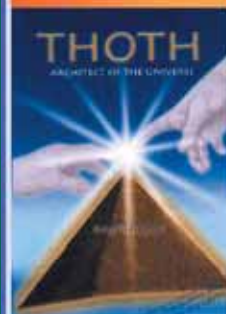

Thoth

Megalithic maps of the Earth.

K2

The Great Pyramid of the Himalaya.



Quality books with color plates.

Available from all good bookshops.

Mail order: **Adventures Unlimited**

Tel: (815) 253 9000

info@adventuresunlimitedpress.com

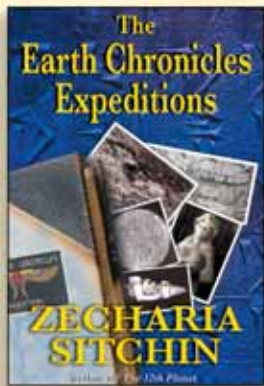

The Earth Chronicles Expeditions

ZECHARIA SITCHIN

Zecharia Sitchin, author of *The Earth Chronicles* series, reveals the research supporting his conclusion that ancient myths are recollections of actual events, the gods of ancient peoples were visitors from another planet, and that we are not alone in our solar system. *The Earth Chronicles Expeditions* is a historical and archaeological adventure into the origins of mankind.

\$16.00 paper, 288 pages, 6 x 9, Includes 158 b&w illustrations and a 32-page color insert consisting of 64 color plates
ISBN-13: 978-1-59143-076-6

Journeys to the Mythical Past

ZECHARIA SITCHIN

Renowned researcher of antiquity Zecharia Sitchin tells his own story, revealing for the first time how his life was at risk inside the Great Pyramid and documenting the existence of a secret chamber. Sitchin's firsthand accounts take the reader into the inner workings of the Vatican, and report on the Iceman of the Alps and the Antikythera computer.

\$24.00, 256 pages, 6 x 9, hardcover, 130 b&w illustrations and a 32-page color insert consisting of 48 color plates
ISBN-13: 978-1-59143-080-3

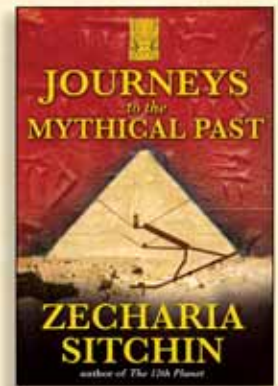

The Templar Pirates

The Secret Alliance to Build the New Jerusalem

ERNESTO FRERS

When the Vatican condemned the Templars in 1312, many of those who escaped took to the sea. Their immediate objective was to take revenge on the Church. Recent discoveries confirm that these ships later reappeared to menace the Church's maritime commerce, spreading a reign of terror across the shipping lanes of the New World.

\$14.95, paper, 192 pages, 6 x 9, 56 b&w illustrations
ISBN-13: 978-1-59477-146-0

Christopher Columbus, the Last Templar

RUGGERO MARINO

According to historic documents and maps revealed by Ruggero Marino, Columbus knew, sailing west, he would find the "New World," not Asia. *Christopher Columbus, the Last Templar* is the untold story of the secret alliance behind the "discovery" of America, revealing how a utopian dream of brotherhood fueled a murderous power struggle involving secret societies, popes, and kings.

\$19.95, paper, 392 pages, 6 x 9
Includes 8-page color insert and 2 b&w illustrations
ISBN-13: 978-1-59477-190-3

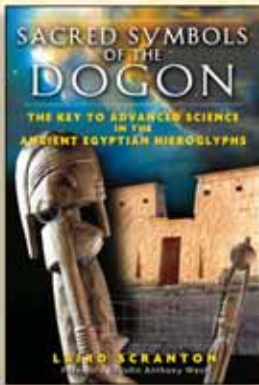
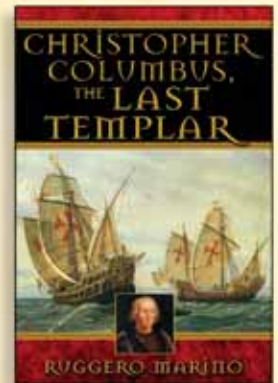

Sacred Symbols of the Dogon

The Key to Advanced Science in the Ancient Egyptian Hieroglyphs

LAIRD SCRANTON

Foreword by John Anthony West

Using Dogon symbols as a "Rosetta stone," Laird Scranton reveals references within the ancient Egyptian language that correlate to a wide range of modern scientific components of matter. The author's findings provide an entirely new

understanding of Egyptian hieroglyphs—that they were scientific symbols based on Dogon cosmological drawings.

\$18.95, paper, 272 pages, 6 x 9, 4 b&w illustrations
ISBN-13: 978-1-59477-134-7

The Spiritual Technology of Ancient Egypt

Sacred Science and the Mystery of Consciousness

EDWARD F. MALKOWSKI

Building on René A. Schwaller de Lubicz's systematic study of Luxor's Temple of Amun-Mut-Khonsu during the 1940s and '50s, Edward Malkowski shows that the ancient Egyptians' worldview was not based on superstition or the invention of myth but was the result of direct observation using critical faculties attuned to the quantum manifestation of the universe.

\$22.95, paper, 448 pages, 6 x 9, 35 b&w illustrations
ISBN-13: 978-1-59477-186-6

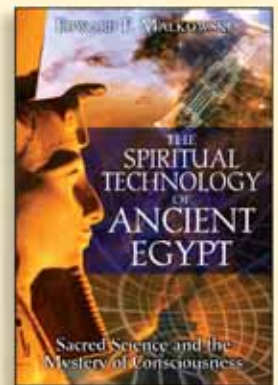

For these and other great titles visit us at

www.InnerTraditions.com

800-246-8648

GETTING AT THE FACTS

Stanton Friedman Explains What We Can Expect from the New 'Openness'

• BY MICHAEL LOHR

In March, the French National Space Agency announced, to much public fanfare, that it would release all of its UFO files. Following the French lead, Great Britain's Ministry of Defense soon stated it would do the same. According to the British newspaper *The Guardian*, the government was planning to make public its own "X-files" on all UFO sightings since 1967. The disclosure is also supposed to include previously unreleased files on the 1980 Rendlesham Forest incident. (Also known as "Britain's Roswell," the Rendlesham Forest Incident refers to a series of reported sightings of unexplained lights and objects in the sky, and the alleged landing of an extraterrestrial spacecraft, in December 1980, near Suffolk.) Of the documents due for release, many are eyewitness accounts from civilian pilots and military personnel covering many such incidents. Most reports were compiled and maintained by the DI55, a secretive intelligence unit within the Ministry of Defense.

Even after a gesture of such seeming good will, however, many UFO researchers remain very skeptical about the value of the information said to be forthcoming. And for good reason, they believe. Previous official promises of full disclosure have led to only more outraged cries of controversy, conspiracy and coverup. The recent U.S. Air Force's purported declassification of documents on Roswell, it is recalled, quickly degenerated into a conspiracy-charged debacle. To gauge the reaction of the UFO community at large to new government overtures we talked to prominent researcher Stanton Friedman.

Perhaps the world's best known UFO researcher, Friedman has advanced degrees in Physics from the University of Chicago and almost two decades of professional experience as a nuclear physicist. Friedman has written books on the UFO phenomenon and was the first civilian investigator of the Roswell UFO incident. Since 1967, according to *Wikipedia*, he has spoken about UFOs at more than 600 colleges and universities and more than 100 professional groups in the USA, Canada, and 16 other countries. He currently lives in Canada.

For Friedman, the 'newfound openness' does NOT mean that new revelations can be expected. We wondered if he foresees any changes at all in current government secrecy policies—does he see these developments as of potentially historic import? We found him any-

thing but optimistic about the prospects.

"The significance of the move has been considerably overstated," he shrugged. "The French files were not Defense department files; they were civilian files often compiled with the help of the local gendarmes." The distinction between civilian and defense-related reports is crucial for Friedman, "The U.S. Project Blue Book files," he explains, "have been available for review—about 13,000 cases in all—since the mid 1970s." (Project Blue Book was one of a series of systematic studies of UFOs conducted by the U.S. Air Force. Started in 1952, it was the second revival of such a study. A termination order was given in December 1969, and all activity under its auspices ceased in January 1970.) Friedman elaborates, "I refer people to the very important memo by General Carroll Bolender (project head) dated October 20, 1969 in which he stated, 'Moreover, reports of UFOs, which could

affect national security, are made in accordance with JANAP-146 or Air Force Manual 55-11. These are not part of the Blue Book System.' " In other words, the really important stuff remained secret.

Friedman, of course, knows the material inside and out. There are few UFO-oriented documents, no matter how obscure, with which he is not familiar. He goes on to argue how the closing of Project Blue Book did not mean the Air Force was through with UFOs, just that it was through with those events which it deemed not important to national defense. "In the second paragraph of the memo," he points out, "after noting that with the closure of Project Blue Book, the public won't have a place to report sightings, General Bolender delivers a caveat to the ruling. 'However, as already stated, reports of UFOs which could affect national security would continue to be handled through the *standard Air Force procedures designed for this purpose.*' These reports have

not been released. Blue Book was *not* on the distribution list for the work done under JANAP 146 or Air Force Manual 55-11, therefore those reports were excluded from release."

The practical effect of all this is that any UFO encounter that the government considers a high security risk can be kept legally classified and buried under tons of bureaucracy beyond the reach of prying investigators. It is within the discretion of the military to decide which UFO sightings are to be investigated further and which of them it will dismiss, so, it seems the new document release plans have essentially changed nothing. Friedman concurs. "I managed to locate General Bolender and asked him about the (Blue Book)

memo. He knew exactly what he was saying. Obviously, the most impor-



Continued on Page 27

The ESSENTIAL ALTERNATIVE SCIENCE BOOKSHELF

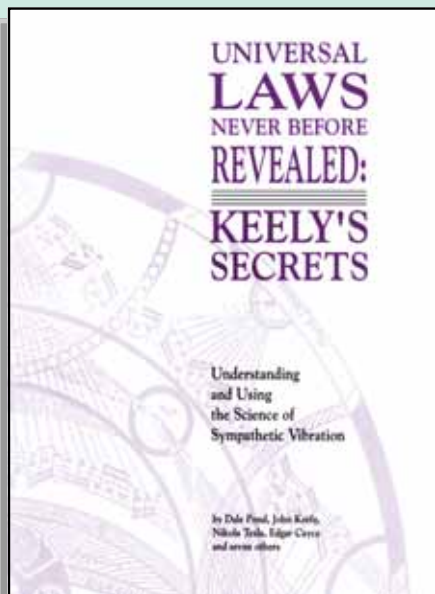

UNIVERSAL LAWS, NEVER BEFORE REVEALED: KEELY'S SECRETS

Understanding and Using the Science of Sympathetic Vibration

Dale Pond, John Keely, Nikola Tesla, Edgar Cayce and others.

One hundred years ago, scientist/inventor/philosopher John Keely built various devices that were able to overcome gravity, tunnel through rock using a hand-held device, use acoustics to power engines, and create superconductivity by using wires made of gold, silver and platinum. Almost lost, this book finally compiles ten years of research by the editor/author that explains the technology used. Understandable to the laymen and useful to the most advanced teacher.

Paperback, 288 pages, 8 1/2 X 11 illustrated

\$19⁹⁵



THE PHYSICS OF LOVE: The Ultimate Universal Laws

Dale Pond, Edgar Cayce, John Keely, Rudolf Steiner, Nikola Tesla

Explore the physics of love and consciousness in an easy-to-understand and exciting manner. The universal laws in this book are applicable to music, electronics, mechanics, healing and all branches of science and philosophy. This science demonstrates the commonality that underlies all phenomena—vibration. Another name for Sympathetic Vibration is Love. Science and Spirituality are finally reunited.

152 pages, 9 X 11 Paperback, Illustrated

\$15⁹⁵

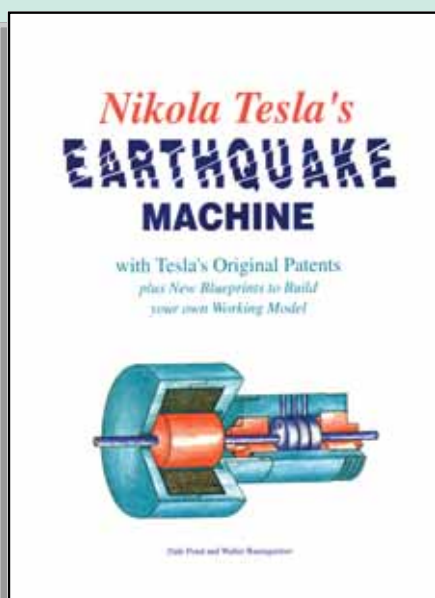
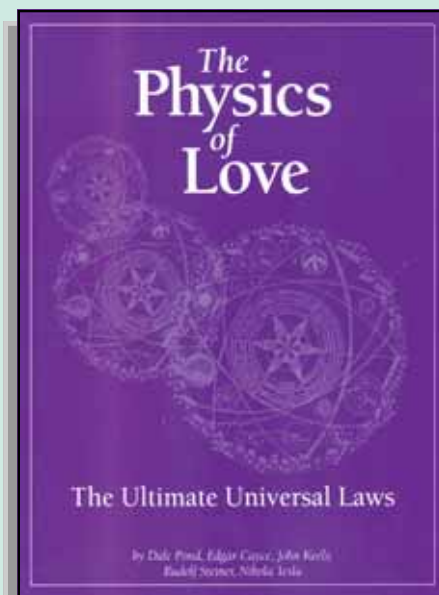

NIKLOLA TESLA'S EARTHQUAKE MACHINE

With Tesla's Original Patents Plus New Blueprints to Build Your Own Working Model

Dale Pond and Walter Baumgartner

In 1935, Nikola Tesla revealed that an earthquake in the region of his New York laboratory in 1898, was the result of a machine he had been experimenting with. This book presents this technology based on sonic vibrations. Now, for the first time, the secrets of the Tesla Oscillator are available to both the layman and advanced researcher.

176 pages, 8 X 11 Paperback, illustrated

\$16⁹⁵

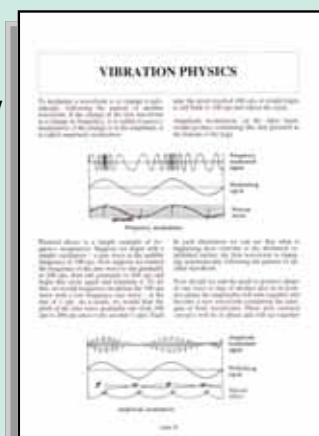

S&H \$5.95 for one book. Add \$2.50 for each additional

Send Check or M.O. to ATLANTIS RISING • P.O. Box 441 • LIVINGSTON, MT 59047 or call 800-228-8381

Continued from Page 25

tant sightings are those which could affect national security such as flights down the runways of SAC bases where nuclear weapons are being stored."

"Also qualifying for this caveat," says Friedman, "would be multiple radar and visual observations of close encounters between military aircraft and UFOs. In the course of my lecturing in 18 countries I have heard seven different reports of more planes going up to chase UFOs than what came back down. In a new book *Shoot Them Down* by Frank Feschino Jr., for which I wrote the foreword and epilogue, it is made clear that military pilots in 1952 were ordered to shoot UFOs down if they didn't land when instructed to do so. An unnamed Air Force General stated that jets had been scrambled hundreds of times over the course of years to deal with UFO-related incidents. It should be noted that the venerable newspaper, *The New York Times* between 1950 and 1955 noted more than 200 military plane crashes, and sometimes used terminology such as 'disappeared' and 'disintegrated' to describe the fate of the planes and pilots. Three of the crashes involved pilots who had survived over 100 combat missions in Korea where MIGs were shooting at them, only to come back to the USA and crash? That seems a little dubious. Having worked under security as a nuclear physicist for 14 years, I can certainly say that secrets are *easy* to keep."

A particularly good example which makes Friedman's point is the Condign report, the comprehensive British government study of a few years ago. Codenamed 'Project Condign', the report was the most highly classified UFO document ever released under the UK's Freedom of Information Act. Before it was released, 'Condign' was rumored to contain significant information. Alas, such turned out not to be the case. "I was certainly not impressed," Friedman says, "by what I read of the Condign report and expect that, likewise, the most highly classified UK or French UFO reports will *not* see the light of day." Answering the question of whether there has been an official coverup of the truth about UFOs for the last 60 years, Friedman believes, is quite easy. "Not only from the perspective of what happened at Roswell in July 1947, but as demonstrated by the blacked out and whited out formerly TOP SECRET Code Word CIA and NSA UFO documents, which are more than 95% censored. I have been to twenty different Document Ar-

chives. There are loads of *still-classified* documents awaiting review."

So, not surprisingly, the release of government UFO documents appears, to the UFO research community, to be little more than hyperbole and the latest iteration of a familiar and stale game of bureaucratic disinformation. But, for many, the important question still remains, why? What, they wonder, is the point of leading people to expect openness and disclosure, only to deliver essentially nothing? And if you're a governmental agency, whether in the U.S., France, the U.K. or elsewhere, working on the assumption that UFO investigators are nothing more than a subculture of oddballs, what is the point of releasing any files at all? Why stir the pot in the first place? Answers to such questions remain illusive, to say the least.

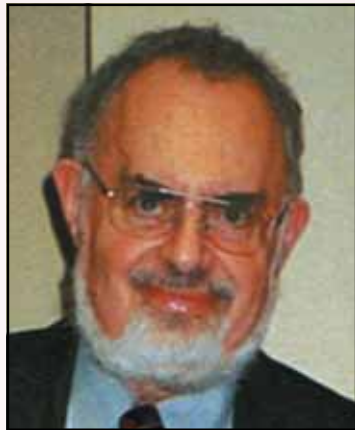

Stanton Friedman

At this point, most UFOlogists have concluded that the Freedom of Information Act, whether the U.S. or British version, is, in fact, nothing but a farce—another governmental illusion created to cloud the waters. When, as Friedman points out, a majority of the official documentation released has been thoroughly censored, why go to the trouble of providing the material in the first place? Other than to maintain the pretense of carrying

out what many consider to be phony policies aimed at preserving the appearance of candor, it appears that little of actual substance ever sees the light of day. Indeed, for long-time UFO researchers, like Friedman, it all suggests a certain arrogance and level of disregard for the public whose taxes pay the salaries of those faceless bureaucrats laboring with black felt tip pens to obliterate anything which in their estimation might threaten hidden government interests.

Friedman has just completed a new book on the famous Betty and Barney Hill UFO abduction case of 1961. Entitled *Captured! The True Story of the World's First Documented Alien Abduction, The Betty and Barney Hill UFO Experience*, the book is co-authored with Betty's niece Kathleen Marden and examines in detail the celebrated Zeta Reticuli star map drawn from Betty's account. The book looks closely at the astronomical significance of the map, and rebuts the arguments of debunkers and skeptics. For more information on Stanton Friedman please check out his official web site: <http://www.stantonfriedman.com/>. ■

Michael Lohr is a professional journalist and freelance writer. His writings have appeared in numerous publications. His webpage can be found at: http://www.internet.is/artist/writer/michael_lohr.htm.

**Don't Miss Out
on the
Adventure...**

**Subscribe to
ATLANTIS
RISING
today!**

**Share it with
a friend...Get a
2nd subscription
FREE!***

6 Issues (one year)
only \$24.95
30% OFF Newsstand price!

12 Issues (two years)
only \$40.00
43% OFF Newsstand price!

And **We Pay** Postage!**

Call 800-228-8381



* **WHEN YOU BUY ONE SUBSCRIPTION (EITHER 6 OR 12 ISSUES) WE'LL SEND YOUR FRIEND A SECOND SUBSCRIPTION FREE! MUST BE AT LEAST 100 MILES AWAY.**

** **SEE MAILING POLICIES FOR FIRST CLASS AND FOREIGN POSTAGE RATES.**

Beneath Modern Moscow a Centuries-Old Search Continues for

• BY STEVEN SORA

Students of history, religion, science and sociology can never forgive the destruction of some of the world's most important libraries. The library at Alexandria once held 500,000 volumes before it was destroyed by Julius Caesar, and the library at Carthage with 200,000 volumes met the same fate after war with Rome. The Chinese Emperor Shi-Hwang-ti had all his kingdom's books burned in 214 B.C., and Mao revived this tradition in 1966. From ancient Pergamus to modern Germany, books and libraries have regularly come under attack. One of the greatest libraries, however, was saved at the last minute from destruction, only to be lost. Literally.

In the middle of the fifteenth century the Ottoman Empire was spreading west, conquering everything in its path. It was only a matter of time before Constantinople itself would be invaded by the Asian hordes. Constantinople was nearly two thousand years old when the Turks threatened it. Founded by a Greek, Byzas, in 667 B.C., the city had survived an earlier catastrophe in 1204 when the Christian crusaders decided on looting the city as a dress rehearsal for conquering Jerusalem. The lesson, having been learned the hard way, was not forgotten.

The greatest treasures of the city were to be protected at all costs. Sultan Mahomet II with an army of one hundred and fifty thousand men was on his way. Constantine XI had a force only one tenth of his enemy and this included his Genoese mercenaries. Defeat was just a matter of time.

The niece of the emperor, Sophia Palaeologa, was hastily married to the young Ivan III who would soon become the ruler of Russia. Her entourage left the city and made it to Moscow via Rome. Her baggage included the treasures of the Byzantine and also the treasures of Constantinople's library.

This was no ordinary library, and it may have been the greatest library outside the Vatican at that time. Chronicles preserved in Moscow state one hundred carts of rare books traveled overland. Books from Asia, Africa and Europe written in Hebrew, Arabic, Greek, Latin and Egyptian were part of the library. Early editions of Pindar, Polybius, Tacitus and Cicero were also part of the library, as were the poems of Kalvos, the works of Virgil and the "Lives of the Twelve Caesars" by Suetonius. Many were written by hand and were considered one-of-a-kind. Seven hundred books were editions bound for the emperors themselves and encrusted in jewels. The value of the library was then and now incalculable.

Sophia (also known as Zoe) and her treasures made it to the safety of Moscow and her new husband via Rome. She also collected a handful of Italian artists and architects who would participate in the modernization of the Kremlin. One hope, that of uniting the Orthodox Church of Constantinople, the last vestige of the Roman Empire, with the Orthodox church of Russia was never achieved. There would be no theological union, and it would quickly be known there was no hope of a military union. And the fate of Constantinople was sealed.

The troops of the Ottoman sultan would overwhelm the city's walls with cannon and sheer numbers. The Ottoman navy surrounded the port. When chains were put



The double-headed eagle became the Russian symbol during the time of Ivan III

THE LOST LIBRARY OF IVAN THE GREAT

across the harbor, Mahomet had his ships put on rollers, pulled overland and re-launched at a point past the blockade. When the ships reached the inner harbor, cannons brought down the walls, and the massive military contingent entered the city on May 29, 1453. The culmination of a seven-week siege had the Ottoman leader hailed as Fatih (the Conqueror) as he rode on horseback into the Hagia Sophia, the greatest Church in the World.

Massacre and pillage followed as Constantinople was "converted" into Istanbul, the capital of the Turkish Empire. The greatest church, one hundred and eighty feet tall, became a mosque and others were quickly constructed. The Eastern Roman Empire was no more. Moscow now became the head of the Orthodox Christian Church. A Russian Orthodox monk, Philotheos, declared Moscow "the Third Rome."

A New Home for Constantinople's Treasures

One of Ivan III's most lasting achievements was to begin the building of the Kremlin into what it is today. In his time it was a three-hundred-year-old encampment built of wood. Standing tall it had turned back numerous assaults and the old-Russian word for "citadel," *kremnl*, served as the base of the modern word, kremlin. He took the 130-acre fortress and replaced wood with brick and stone. Much of the brick work that has survived until modern times is the original.

The reason for the upgrade from oak to stone was that Sophia requested of her husband that the books she had brought from Constantinople be safe from the fires that regularly plagued the fortress. Cathedrals of wood and barracks and homes would burn from

Continued on Page 30

Supressed Inventions!

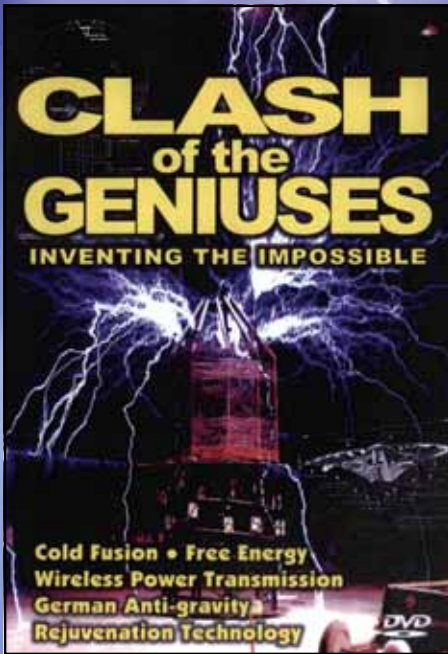

In the 20th century, while the Marconi's...the Henry Ford's...the Thomas Edison's have succeeded in capturing most of the attention, others with technological prowess bordering on the miraculous, strangely, have gone unnoticed. Men with names like Tesla, Moray, Rife, Russell and Schauburger, laboring in almost complete obscurity, and achieving almost incomprehensible miracles-free energy, anti-gravity, transmutation of the elements, physical rejuvenation and more-were yet largely rejected, ridiculed and despised by the scientific establishment of their day. But now, a few decades later, a new breed of inventors, scientists and researchers is making rapid, if yet unpublicized, strides toward unraveling the secrets of those unsung giants who preceded them. Many now find themselves on the threshold of breakthroughs, still believed, by many, to be the stuff of hallucination. **Atlantis Rising Video** now tells their story.

1 Hr. DVD \$24.95
or VHS \$19.95

+ \$5.95 S.&H.

To Order Call

800-228-8381

November 16-19
Phoenix, AZ

Shh... It's A SECRET!
CONFERENCE

Lynne McTAGGART
Barbara MARCINIAK
Daniel PINCHBECK
Jim MARRS
Linda M. HOWE
William HENRY
Philip GARDINER
Nick BEGICH
Bert Janssen
Chet Snow



Dr. Chet Snow - Box 1738 - Sedona AZ 86339
Tel: (928) 204-1962 - Fax: (928) 204-1955

www.chetsnow.com/signs.html

Tempe Embassy Suites Hotel

4400 S. Rural Rd, Tempe, Arizona - (480) 897-7444

A 2-Room Suite is \$119 - with free breakfast & cocktail hour
This is a space-avallable Conference rate.



From government jobs to student loans
to buying surplus government property,
all kinds of government information
are just a click or call away.

FIRSTGOV.gov

1 (800) FED-INFO

TWO FREE MAGAZINES!
BIZARRE
BAZAAR
& **CONSPIRACY**
JOURNAL

SIGN UP FOR A FREE SUBSCRIPTION

Our Two Publications—Bizarre Bazaar
and Conspiracy Journal—are unlike
anything you've read before! Send your
name and address by email to:
MRUFO@webtv.net or mail this ad to:

Global Box 753-AR
New Brunswick, NJ 08903
732-602-3407

pected of finishing him off with more poison. While Ivan was losing his mind and finally his life, Russia was losing the knowledge of the library's location. More important issues allowed the library to be nearly forgotten. Moscow itself would fall from importance when Peter the great czar and emperor modernized his country. Peter might have moved the library, if he found it, but despite a massive search the maze under the Kremlin defied even the Romanov emperor.

The Search for the Lost Library

Fast forward past the days of the czars to the time of the dictators and the library was still missing. Joseph Stalin wished to create one of the world's greatest subway systems. The massive tunneling which is today evident in the endless escalators that seem to descend to the earth's core was done with care in the hopes that one of the secret rooms of the library would be uncovered. Over one hundred subway stations, many decorated with artworks, are connected by miles of track stretching throughout the city. But none penetrated the "Liberia" of Ivan III as the library became known. Even a secret subway designed to protect the rulers and generals never uncovered the treasures of the Byzantines.

As Moscow improved its infrastructure, numerous underground levels were built. While no one knows for sure, in some places it is believed there are as many as twelve. Subways, water tunnels, a sewage system, and the passageways that are long forgotten have never been mapped.

Nikita Khrushchev, in the 1960s brought about even more development under the Kremlin. He further extended the subway system and may have merged the secret subway with the public metro, although not all of it. The Arbatskaya station is just under the ministry of Defense and secret doors are always under active guard. While many stations are beautifully designed and appointed with artwork, no photographs are allowed. Tourists are warned that even if they think they can sneak a photo or two, they will not get away unseen. Khrushchev, too, wished to uncover the famed library. He instructed the project managers to take all steps necessary to locate and preserve with care the library of Ivan. But despite his instructions, all the dictator's men could not uncover what the czar's men covered.

In the 1990s the mayor of Moscow, Yuri Luzhkov renewed the hunt for the library. One of the hopes of the search was possibly to open the underground for tourism. Visitors to the Kremlin are often rudely awak-

Continued from Page 28

normal affairs to Tartar attacks, and the library needed to be safe from that threat. Another threat, voiced by her uncle, was that he believed the library was coveted by Rome and the Vatican. They had offered to buy the complete collection, and the emperor had turned the offer down. Would Rome use force? For this reason Moscow was chosen.

Ivan went a step further and built the vaults of the "Liberia" as the library came to be known, underground. The Italian architect Ridolfo (Aristotle) di Fioravanti had the job of constructing the vault deep under the Kremlin. There were once believed to be three hundred underground tributaries of the Muscovy River. The architect would close off such waterways, then line the walls with brick. No one knows just how many rooms and tunnels exist in the labyrinth under the Kremlin.

Meet the New Boss

When Ivan III, (aka Ivan the Great) died, the rule of Russia passed to Ivan IV who is known to history as the Terrible. The word terrible actually once meant "awesome," but Ivan was a terrible person even though his ability to rule was "awesome." He detested the aristocracy of Russia called the boyars. For them he extended his underground city further. The labyrinth under the Kremlin now included prisons and torture chambers designed to break the power of these elite families.

At first he targeted specific families that had "neglected" him. However, his cruelty went beyond the practical, and evil, growth of power. He even threw cats and dogs out of Kremlin windows. His secret police, the Oprichniks, grew more violent as their "Czar" became more unbalanced. Ivan was the first to take that title which is derived from Caesar. After stripping the boyars of their wealth he took to attacking his own population. The Massacre of Novgorod saw over thirty thousand Russians killed and the city nearly depopulated. He beat his daughter-in-law until she miscarried and then killed his son who had tried to stop him.

Ivan's reign of terror did not end until his death. In his last three years he had suffered from a horrific disease that bloated his features and caused him to emit ghastly odors. Most likely it was the result of poisoning, and the last person to see him alive was his adversary in chess, Boris Godenov, who was sus-



Ivan the Terrible

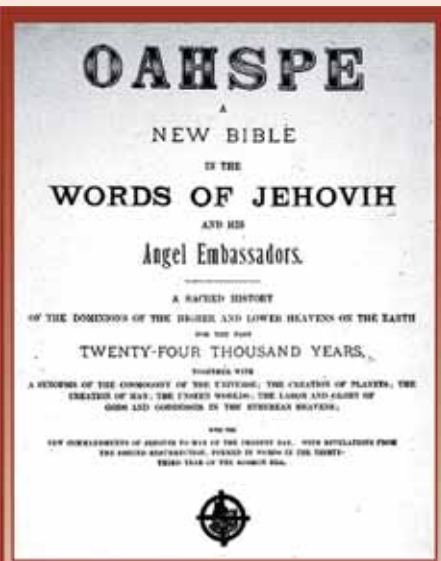

OAH SPE

THE BOOK FOR THE AGES

In 1882, Dr. John Newbrough received spiritual guidance through automatic writing and transcribed Oahspe. This book gives a history of the Earth from man's arrival on the planet, about 80,000 years ago, including an account of the sinking of the continent Pan in the Pacific (a.k.a. Lemuria or Mu) up to modern times. It sets into perspective the traditional religions, how they came into being, how their respective eras are drawing to an end, and how man is now to worship the Great Spirit, Jehovih, on an individual basis with no need for an orthodox "church" as intermediary. OAH SPE speaks of the necessity in these times to lead a peaceful lifestyle in small, cooperative, vegetarian communities. It describes the inter-relationship of the spiritual and mortal worlds, the influence of the unseen on the seen, the vastness of the universe in the unseen (Etherean) realms, travel in "starships" therein, and hope for a peaceful future on Earth by describing the essential nature of a new paradigm to come. \$21.95 (shipping incl.) Order from:

UNIVERSAL FAITHISTS OF KOSMON, INC.
 3439 GRAND VALLEY CANAL ROAD
 CLIFTON, COLORADO 81520
 Phone ~ 970-434-5665
 Fax ~ 970-434-3308
 E-Mail ~ cvostatek@prodigy.net

The **Atlantis** CONSPIRACY

THE ATLANTIS CONSPIRACY summarizes the evidence that the world today is slowly coming under the control of a group of conspirators whose secret organization began some 12,000 years ago in legendary Atlantis. This book "connects the dots," showing the pattern behind UFOs, the paranormal, lost civilizations, and sinister events such as the Kennedy assassination.

Former Air Force Intelligence Officer William ('Ben') Stoecker was driven to seek the truth through a lifetime of thought and study. A UFO abductee, repeated paranormal experiences and encounters with sinister former members of the secret elite UFO crash-retrieval unit left him with no other option. The conclusions he reached will shock and even outrage you.

Softcover, 5.5 x 8.5, 186 pages • \$13.95

(+ \$5.95 S.&H.)

TGS PUBLISHERS
22241 PINEDALE LANE, FRANKSTON, TEXAS 75763
903-876-3256 —HiddenMysteries.com

Telepathy

a Sympathy of Souls

**What Can
21st Century
Science Learn
from the
Pioneers of
Psi Research?**

• BY ROBERT M. SCHOCH, Ph. D.

Glory to the Hero (Nicholas Roerich)

While on a mission to meet with the French King Henry the Fourth, the cleric and poet John Donne (1572-1631) had a vision. He saw his wife carrying a dead child in her arms. At the time his wife was pregnant, and Donne was so taken by the incident that a messenger was dispatched to England to check on his wife. Unfortunately, it was learned, Donne's wife had gone into labor and delivered a stillborn, and this occurred on the same day and, as far as could be determined, around the same hour that Donne saw the apparition.

Somewhat apologetically this story is related by Donne's biographer Izaak Walton (1593-1683).

"This is a relation that will beget some wonder, and it well may; for most of our world are at present possessed with an opinion, that visions and miracles are ceased. And, though it is most certain, that two lutes being both strung and tuned to an equal pitch, and then one played upon, the

other, that is not touched, being laid upon a table at a fit distance, will—like an echo to a trumpet—warble a faint audible harmony in answer to the same tune; yet many will not believe there is any such thing as a sympathy of souls; and I am well pleased, that every Reader do enjoy his own opinion." (Izaak Walton, 1640)

Indeed, although such a story may to this day "beget some wonder," similar incidents have been recorded over and over again. Such cases are encountered throughout the annals of history and are found among all cultures and societies, savage and civilized, oriental and occidental. But, do they have any significance and meaning? Are they simply to be dismissed as chance coincidences or faulty reporting combined with perhaps overly vivid imaginations?

In order to address these types of questions systematically and scientifically, in London in the year 1882 was founded the Society for Psychical Research (SPR). One of the first tasks of the SPR was to collect cases

similar to the one recorded for John Donne. But the SPR did not simply scour the literature for cases; it actively sought out then recent cases (primarily from the 1870s and 1880s) that could be well documented. They interviewed witnesses and checked and cross-checked facts and data to ensure, to the best of their ability, that they were not being duped by fabricated stories (whether purposefully or simply due to faulty memories). In 1886 the fruits of their labors up to that point were published as a massive two-volume work titled *Phantasms of the Living* (by E. Gurney, F. Myers, and F. Podmore).

The title of this work bears some explanation. The core of *Phantasms* is a collection of "crisis apparitions" or "crisis hallucinations" (sometimes referred to as cases of "crisis telepathy") that occur to a "receiver" or "percipient" in conjunction with a crisis situation, often death, near death, or some other very traumatic incident such as the stillborn child in John Donne's case, on the part of the "agent" or "sender." The authors of *Phan-*

tasms interpreted such apparitions to be veridical (carrying true information) hallucinations formed in the mind of the percipient based on information telepathically communicated from the agent, often at the approximate moment of death (although the telepathic message might be received in the subconscious of the agent, and remain dormant or latent for a period of time, before being brought to the conscious realm). The word phantasm, etymologically related to phantom, refers to any such apparitions or hallucinations. As used in *Phantasms*, the term "hallucination" could refer to a visual hallucination, an auditory hallucination, an olfactory hallucination, a tactile hallucination (such as the feeling of being punched or brushed against), or even what might be called emotional or ideational hallucinations and impressions (suddenly feeling sad, or the idea enters one's head that a friend or family member is in trouble or just died). The title of the work, *Phantasms of the Living*, stresses the notion that living persons transmitted the telepathic messages catalogued in the work.

Phantasms includes 702 cases plus analyses of the common characteristics and patterns found among them. Perhaps most importantly, *Phantasms* includes a statistical analysis that strongly supports the argument that all of these cases cannot be the result of "chance coincidence." The primary author, Edmund Gurney, based on surveys of thousands of people, takes into account such factors as how often people simply "hallucinate"

an apparition; how often a relative, friend, or acquaintance will die; what the chances are that the death and hallucination will coincide; and so forth. In the end, he develops a very powerful argument that the vast majority, if not all, of the cases meticulously recorded in the two volumes must have meaningful significance.

To this day *Phantasms* sets a standard, and stands as a valuable collection of raw data, for the study of this aspect of the paranormal—apparent mind-to-mind communication between individuals; that is, telepathy. Subsequent studies have served to support

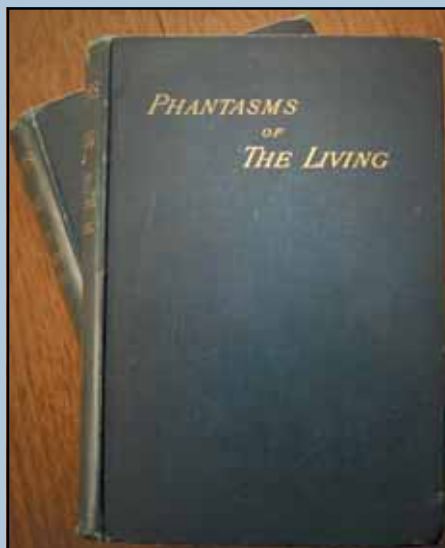

and complement the findings published in *Phantasms*, including a "Census of Hallucinations," based on surveying 17,000 people, published by the SPR in 1894. It is important to note that arguably the data on crisis apparitions collected in the nineteenth century could never be duplicated today. Much of this data was compiled before the widespread use of means of quick communication, such as telephones and telegraphs. So when a soldier stationed in India hallucinated one night that his grandmother, who was in England, was standing at the foot of his bed, he had plenty of opportunity to mention this hallucination to friends (who could then independently verify his story) before receiving a letter, perhaps a week or two or a month later, announcing that his grandmother had died that night. In our day of virtually instantaneous communication, we immediately question anyone who claims to have had a hallucination prior to learning of her or his grandmother's death. Even if such a story is given in good faith, it can easily be argued that the "percipient" is "confused" as to the timing of the hallucination and the time when the news of the death was received.

Crisis apparitions, as collected in *Phantasms*, are examples of a class of "spontaneous psi." Psi is a general term that encompasses two aspects of the paranormal as typically studied by physical researchers and parapsychologists (the two terms are

Continued on Page 62

NEW from Chrysalis Books

A BOOK ABOUT US

The Bible and Stages of Our Lives

GEORGE F. DOLE

978-0-87785-326-8, pb, 96 pp, \$12.95

"George Dole presents an appealing narrative of his own that helps us to see how the Biblical story, with its incredibly vivid characters, both parallels our personal life stories and calls us to reshape them."

—INESE A. RADZINS
Assistant Professor
of Theology and the
Dorothea Harvey
Professor of Sweden-
borgian Studies
at the Pacific
School of Religion

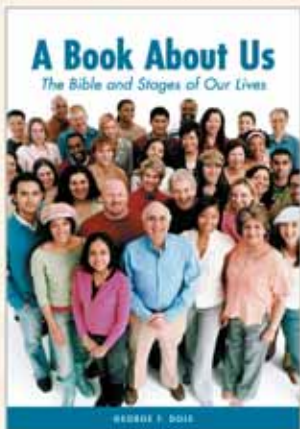

IMAGINE THAT!

Breaking Through to Other Worlds

CAROL S. LAWSON AND ROBERT F. LAWSON, editors

978-0-87785-238-4, pb, 192 pp, \$15.95

"Imagine That!: *Breaking Through to Other Worlds* is a creative interplay of intention and surprise connecting the complexity of culture with God's

infinite wisdom and love. The narrative contribution and the poetry are both fascinating and tremendously inspiring."

—ROBERT LEAS, PH.D.
Emeritus Certified
Supervisor of The
Association for Clinical
Pastoral Ed. Inc., History
Manager for ACPE Inc.

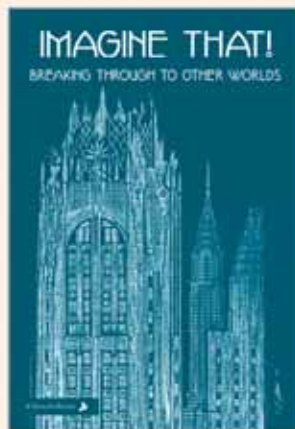

www.swedenborg.com • 800.355.3222, ext. 10

“Dead Doctors Don’t Lie”

*is the largest selling health lecture in the world,
with over 63 millions copies sold!*

The author, Dr. Joel Wallach BS, DVM, ND, has alone and with co-plaintiffs, sued and beaten the FDA 7 times and counting!

According to the August 2005 *Newsweek*, Americans rank 46th in life expectancy!

Healthcare is the #1 cause of death in the United States, according to the non-profit group Nutrition Institute of America!

Learn why Dr. Wallach thinks doctors have created the major diseases that plague us and what we can do to STOP it!

He has formulated products based on the 30 billion dollars of research done on animals and has come up with a human health care package that every American should be on!

For a lifetime membership in American Longevity, you can purchase over 250 all natural products at the wholesale price. You can't get these high dose products any other place!

For a lifetime membership to purchase wholesale, send \$10.00 to:
The Mineral Girls • 8831 Bailey Dr. • Ada, MI 49301
or to charge, call 1-800-969-9272

If you desire, learn how to make this an international business run from your home!

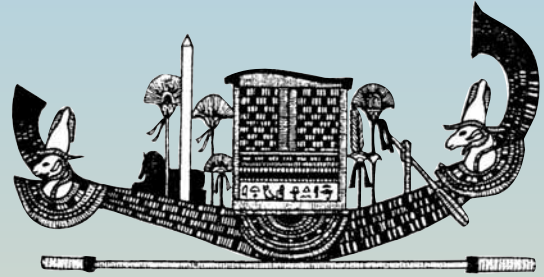

Embark upon the journey of a lifetime!

Mythic Tours

Egypt - March 2009

Walk in ancient temples as peace ambassadors, absorb ancient knowledge, teachings of myths, symbols and star knowledge, engage in deep dream work, experience guided meditations, past life regressions, spiritual ceremony, share life-changing and transforming visions.

Queen of Cups Sacred Travel

970-264-7474

www.queenofcups.com



MAYFAIR BOOK PROMOTION, INC.

PROFESSIONAL PUBLISHING SOLUTIONS

Mayfair Book Promotion and Author Publicity has over 40 years of collective knowledge in all aspects of the publishing dilemma that all authors face. From distribution to manufacturing, from press releases to websites and radio campaigns, Mayfair has the knowledge and the experience to get results for your book or catalog. Our services and related programs are applicable to all genres designed to assist authors, self-publishers and publishing companies. Mayfair has catapulted many authors onto the world stage such as: Philip Gardiner, the international, best selling author of “Gnosis, the Secret of Solomon’s Temple” and Dr. John Jay Harper, author of “Tranceformers: Shamans of the 21st Century.”

Our expertise and experience in the publishing industry enables us to determine a customized plan for maximum impact for our clients. We feel each book is unique in its own right. We evaluate every applicable aspect of your book, from cover art to editing, from annotations to marketing materials, Mayfair will guide you through the process and put years of experience behind your book title giving it a real and tangible edge against your contemporaries. Please visit us online for more information or call us at 866-585-1355.

www.mayfairbooks.com



**Basic
Bookselling
Package**



**Advanced
Bookselling
Package**



**Complete
Audio Book
Package**

• BY SUSAN B. MARTINEZ, Ph.D.

Did you know that earthquakes occur in cycles? Scientists, charting the intensity of seismic upheavals since the 17th century, have come upon “cluster years” marking the most destructive quakes. Regardless of location—China, Italy, western Pacific—there is a definite peak period, every eleven years.

Interesting that the earth’s thermosphere also obeys an 11-year rhythm in its variation from 700 degrees C (at low point) to 2000 degrees (at high point). And in the same vein, the great auroras painting the polar skies give their most lavish displays every eleven years, at which time they may be seen as far south as Athens or Mexico City. Peak-time auroras have been linked, in turn, to unusual weather patterns.

There are important changes also over a period of about 11 years in “solar radiation.” Indeed, the sun itself changes its polarity from north to south every eleven years: magnetic reversal—or what I call oscillation.

The price of wheat, for that matter, seems to fluctuate on an 11-year pattern, as well as cyclones over the oceans, thickness of tree rings, number of icebergs, vintage years for Burgundy wines, the level of Lake Victoria, not to mention all sorts of variations in human behavior—everything from blood pressure to mass migrations.

I know what you’re thinking—sunspots. The 11-year cycle. And, yes, all these surges do correspond to sunspot maxima. But how

could these blotches on the sun’s disc, these bruises or pox—93 million miles away—be the cause of dramatic changes on the earth?

Let’s just backpeddle a moment to consider the possibility (and likelihood) that—these “spots” are not fixed on the sun at all.

For one thing, they have magnetic fields over them: Aha—planets! Not “spots.” Isn’t it evident that planets (of all different shapes and sizes) orbiting in the sun’s photosphere may appear dark? Elsewhere in the solar system are dead planets—millions of them, worlds whose light has gone out, slow-moving and lacking radiation. They cannot be seen, yet some of them may eclipse the sun or be taken for sunspots, even though they may be less than a million miles from the earth. Closer still, not too far above planet Earth, are dark nebulae, cloudlike, which can also blemish the sun’s face, to earth eyes.

Certainly dear old Galileo deserves credit for finding and tracking these “dark regions,” with his newly perfected telescope-and-screen apparatus. But fixtures on the solar orb? scattered over the “face of the sun like acne”? I don’t think so. One theory even argues that two-sunspots-in-a-pair are connected by a U-shaped bridge of material beneath the sun’s surface! It is even harder to picture these blemishes as: intensifying the sun’s heat; throwing out supercharged particles to the earth; effecting our short-wave radio transmissions; ionizing the atmosphere and triggering geomagnetic storms and precarious currents in the earth’s crust.

Have you noticed that Earth Science, despite its modernity, bows to the sun-worship of old, attributing every unknown factor on the terrestrial sphere to the solar king? “Solar wind,” for example, solves all, just as it is presumed to “push” sunspot effects to the very surface of our planet.

But why should the sun’s scars be doing all these mighty things? Especially if the “spots” are, as some scientists note, “regions of reduced efficiency in relation to the rest of the sun’s surface,” i.e., about 1700 degrees C cooler than the surrounding photosphere.

And if these “spots” are indeed nothing more than passing nebulae or dead planets, it seems even more absurd to assign them the far-reaching effects unanimously attributed to sunspots and solar flares.

If we relax for a moment to entertain the possibility that sunspots are not the cause of anything, that they are in fact an optical illusion, we can at least award them a consolation prize as heralds of one of nature’s grandest regularities: the 11-year cadence, the periodicity so basic to cosmic rhythms.

Sometimes dropping to nine years or swelling to 13 years, the inexorable cycle nonetheless hugs the basic eleven and seems to have been a recognized—even revered—unit of Nature’s clockwork long before telescopes or fancy computer models.

If there is such a thing as sacred geometry, we might be tempted to embrace eleven as a prime number. Considered first of the master numbers in numerology, eleven

Continued on Page 37

Solar Flares

SKY & TIME

the Sacred Number 11

UNCOVER THE TRUTH WITH NEW PAGE BOOKS



PSI Spies
The True Story of America's
Psychic Warfare Program
Jim Marrs
EAN 978-1-56414-960-2, U.S. \$15.99

"In *PSI Spies*, Jim Marrs has provided the original report on the U.S. Army's use of psychic remote viewing as an intelligence tool. Here's how military remote viewing got its start."

—Whitley Strieber, best-selling author of *Communion* and *The Grays*

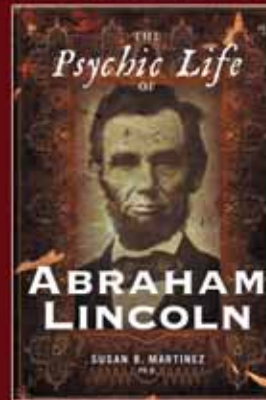

The Psychic Life of Abraham Lincoln
Susan B. Martinez
EAN 978-1-56414-966-4, U.S. \$24.99

"*The Psychic Life of Abraham Lincoln* is a vivid account of the spiritual Lincoln and his search for answers amidst personal and national crisis. Martinez ably dissects a complex and essential part of the Lincoln psyche."

—Neil Dahstrom, author of *Lincoln's Wrath*

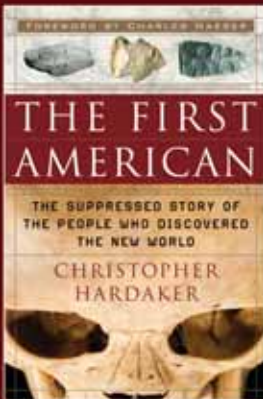

The First American
The Suppressed Story of the People
Who Discovered the New World
Christopher Hardaker
EAN 978-1-56414-942-8, U.S. \$24.99

"Hardaker does us all a service by exposing the facts and fictions behind conventional wisdom about the peopling of the Americas. Shocking and enlightening."

—Graham Hancock, best-selling author of *Fingerprints of the Gods*

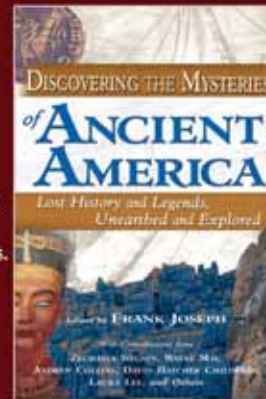

Discovering the Mysteries of Ancient America
Lost History And Legends,
Unearthed And Explored
Edited by Frank Joseph
EAN 978-1-56414-842-1, U.S. \$15.99

Contributors include: Zecharia Sitchin, David Hatcher Childress, Andrew Collins, Laura Lee, Wayne May, and Many Others.

NEWPAGEBOOKS.COM

1-800-227-3371

NEW DVD! **TRUE**
STORIES
of
**SPIRITUALISM,
CONSPIRACY &
MURDER**

Through the use of beautifully crafted illustrations, award winning animation, live action sequences, professional voice actors and a thrilling musical score, we are taken on a journey through time, while unraveling three mysteries for the ages about spiritualism, conspiracy and murder in small town Western New York.

TOTAL RUNNING TIME 90 MINUTES

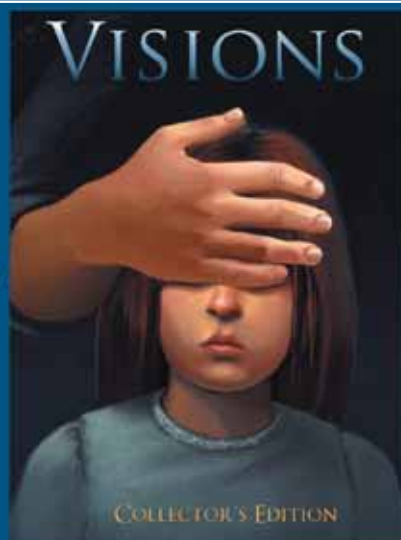

To view trailer visit us at:

\$19.95 + \$4.58H

www.ad-hoc-visions.com

AD-HOC PRODUCTIONS • PO BOX 40805 • ROCHESTER, NY 14604

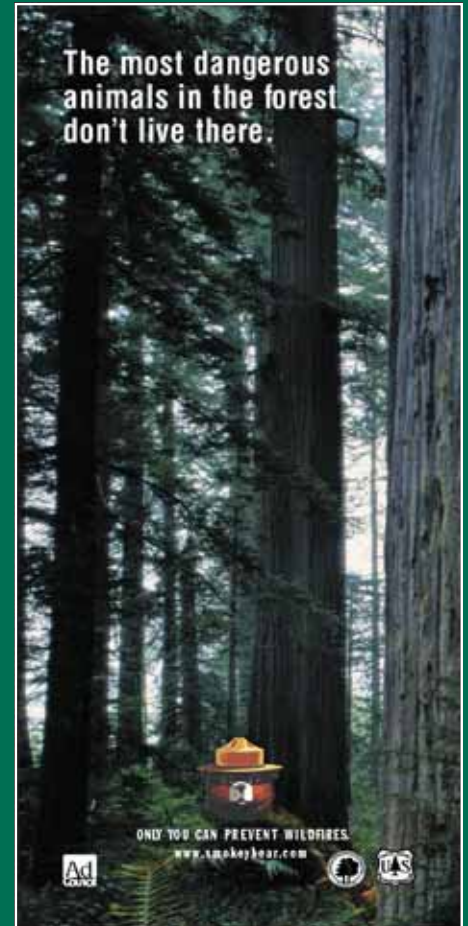

Continued from Page 35

(onze) is also remembered as “the number of the angels” (ange). Dolmens in stone circles sometimes run to eleven in number; just as team size (football, soccer, cricket, etc.) defers to a classic eleven; its dignity is further suggested by the eleven guns fired in standard military salute (Army, Navy, Air Force, Marines).

The Eleusinian Mysteries of ancient Greece gave the town of Eleusis, northwest of Athens, its name: var. Elefsis, lit., devised of eleven. At this celebrated shrine, the earth goddess Demeter inspired rites and initiations of the highest order; even the Christian Cicero praised their pagan mysteries: “They have sweetened our character and softened our customs; they have made us pass from the condition of savages to true humanity. They have not only shown us the way to live joyfully, but they have taught us to die with better hope.”

Meaning: here was centered the Hellenic cult of Immortality, Demeter bearing “ambrosia of the Gods,” which is but a symbol of life everlasting and the secret of secrets: “death is not the end.” In every way the Eleusinian Mysteries echoed the last traces of a chosen people, the wise ones of old: her rites were deathly secret; those accepted for initiation were given a password—just as the Israelites in Egypt, scattered and oppressed, maintained their unity through “rites and signs and passwords.” (In a minute, the Egyptian connection will become clear.) The Eleusinians danced and tranced, chanting to the tinkling of cymbals along the sacred way (processional); they purified themselves in ritual baths; they honored the dead—and the sacred numbers.

I will say this: Today’s hackneyed rendition of ancient “fertility goddesses” (like Demeter) and their cults—supposedly celebrating “the annual death and resurrection of vegetation”—comes off trite and insipid compared to the true original. As goddess of the underworld (i.e., hidden knowledge), Demeter not only brought “the gift of grain,” “the blessings of agriculture,” “the first corn,” and so forth, but, more significantly, bore the mysteries of cycles of growth, the seasons of the earth, a recondite calendar. Her “sacred symbols” held fast to the formulas of forgotten knowledge. To the son of Eleusis’s King, Demeter gave not only mere seeds, but the agrarian secrets of her forefathers. She gave prophecy. She gave sky-time....

The Greeks, as Herodotus surmised, borrowed Demeter from the Egyptians who

were “the cleverest nation in the world.” A thousand years before the myth of Demeter and her Mysteries reached Greece, “Rules of the Seasons of the Earth” were known and codified by the initiated in the land of the Nile.

And here the elementary unit (known as the “short measure”) was called “ode,” and it represented eleven years. The language of the learned, in those days, was different than the native tongues of Egypt. Neither did the learned use the same calendar as the masses, but employed an esoteric time-record known, also, as ode, and signifying—“sky-time.” Hence the equivalence of the 11-year unit and heavenly times.

These were the occult time-counts employed in the Pyramid Age:

First Rule of Prophecy: a spell which = 3 odes which = 33 years (one generation)

Second Rule of Prophecy: an ode which = 11 years

Third Rule of Prophecy: 3 spells which = 99 years (approx. a century)... in addition: a tuff = 11 spells which = 363 years, called “The Solar Year”

“Cosmology is not only a fundamental science; it is also the grandest of the environmental sciences.”—Sir Martin Rees, Astronomer Royal/ Cambridge



Eleusinian Mysteries depicted on Urn

Multiples of 11 thus became the basis of prophecy—and engineering: Applied science of the ancients.

What a contrast to today’s ivory tower science with its politically correct theories, rival models and erudite guesswork. Or even today’s astrology, catering to personal whim, bending prophecy to satisfy the least concerns of self. When the star groups (zodiac) were first given through Osiris more than ten thousand years ago, rather than flattering ego, they marked off “the base of prophecy: the variations of thirty-three years; the times of eleven... so that the seasons might be foretold, and famines averted on the earth.” (Book of Osiris 12:3/*Oahspe*) Famine: Thus did the Greek myth of Demeter explain the prevention of widespread famine: Told as a family drama, the story of Demeter’s mourning for Persephone is really a well-disguised allegory, clothing the secret knowledge of astronomer-priests, whose predictions, based on sacred time-counts, could forecast and anticipate the vagaries of climate.

For they built temples of observation to study the stars. And the prophets and mathematicians plied their formulas and produced estimates that predicted the heat and cold of seasons, the wet and dry; and they put the people to work, accordingly, on canals, irrigation, horticultural schemes, granaries, and disease-prevention; finding ores,



FREE Report and Tape Reveal . . .

“How To Meditate Deeper Than a Zen Monk!”

If you’d like to meditate deeper than a Zen monk, literally at the touch of a button, this may be one of the most important messages you will ever read. Here is why.

Based in part on Nobel Prize-winning research on how “complex systems” (human beings, for instance) evolve to higher levels of functioning, a personal growth program has been created utilizing a powerful audio technology called Holosync®.

A precise combination of audio signals gives the brain a very specific stimulus that creates states of deep meditation — and causes the creation of new mind-enhancing neural connections between left and right brain hemispheres.

Now a New Report & Tape Reveal . . .

- The scientific evidence proving how Holosync® increases the production in the brain of many vital neurochemicals that can slow aging and increase longevity.
- How to achieve super-deep meditation, at the touch of a button.
- How to dramatically reduce stress.
- How to create remarkable emotional changes at the deepest level.
- How to improve your health.
- How to heighten your creativity and problem-solving ability.
- How to have more restful sleep.
- How to boost your intelligence.
- How to increase your focus, concentration and learning ability.
- How to enhance your memory.
- How to have more happiness and “flow” in your life.
- How to heal mental and emotional blocks.

The complete educational report on this amazing new technology and Holosync® tape, worth \$19.95, are FREE to *Atlantis Rising* readers for a limited time.

Call NOW for your FREE report and tape toll-free (24 hrs)

1-800-710-1804

www.magicalmindonline.com

Continued on Page 64

**Ancient
Mysteries**

**Alternative
History**

**Prehistoric
Technologies**

**Extraterrestrial
Intervention**

**Suppressed
Origins of
Civilization**

42 Essays by 17 Key Thinkers in Alternative Science & History

- DARWINISM UNDER FIRE
- EARTH CHANGES—
SUDDEN OR GRADUAL
- CIVILIZATION'S ANTIQUITY
- ANCESTORS FROM SPACE
- ANCIENT HIGH TECH
- LOST ORIGINS
- ATLANTIS UNCOVERED
- BUILDING THE PYRAMIDS

334 pages
color & blw photos

\$18.00 paperback
+ \$5.95 S.&H.

**TO ORDER, CALL
ATLANTIS RISING**

TODAY!

800-228-8381

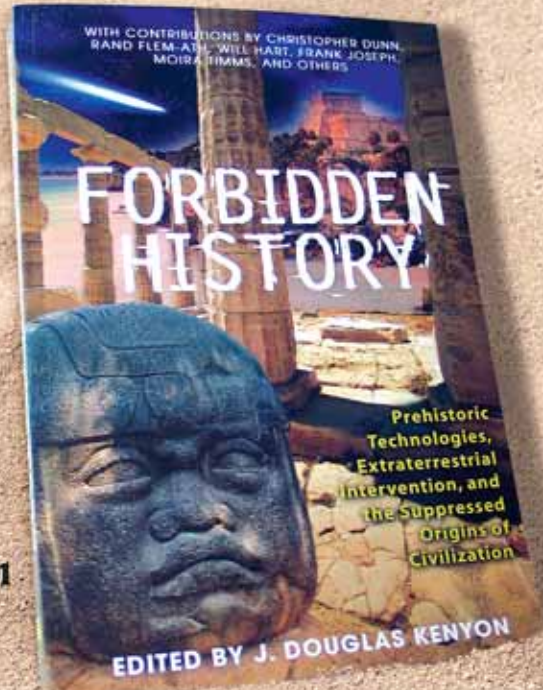

or visit—www.ATLANTIS RISING.com

JUNNER TRADITIONS
SEARCH COMPANY



Advertise in

ATLANTIS RISING

- * GREAT VALUE
- * QUALIFIED NICHE MARKET
- * NATIONWIDE COVERAGE
- * SEEN ON THE WORLDWIDE WEB
- * MASTERCARD/VISA/DISCOVER
- * CHECK OR MONEY ORDER
- * CALL FOR RATES...

Call 800-228-8381

The War for Planet Earth

Part II of the “Nazi/ET Connection” Takes a Closer Look at the Possible Alien Agenda in World War II

• BY LEN KASTEN

We reported in Part I (“The Nazi/ET Connection,” *Atlantis Rising* #65) that, strange as it might sound, the case could be made that German advanced scientific knowledge and weaponry was supplied by extraterrestrials somehow connected with a purported underground civilization in Tibet. Exactly how this information was conveyed is not clear, but some argue that the connection was established through the mediation of Karl Haushofer, and that a group of monks from that underground Tibetan city came to live in Berlin to assist with Hitler’s war plans. They were, reportedly, known as the “Society of Green Men.” There is some evidence to suggest that this situation evolved to the point that aliens were actually working “shoulder-to-shoulder” with German scientists. Hitler envisioned a New World Order to last a thousand years. With the help of architect Albert Speer he designed grandiose buildings and monuments to accommodate his new one-world Aryan civilization, to be supported by the slave labor of the “inferior” races. However, it now seems that this reputed alliance with extraterrestrials was a marriage of convenience, since apparently they had a similar goal and, indeed, may have been using Hitler as some kind of straw man to facilitate their intended takeover of the planet. If all that is true, it puts the European war in a totally new light—just one piece in an elaborate worldwide campaign of alien design, which included the participation of Japan in order to control the seas.

From this perspective, the outbreak of World War II can be viewed as a push by the

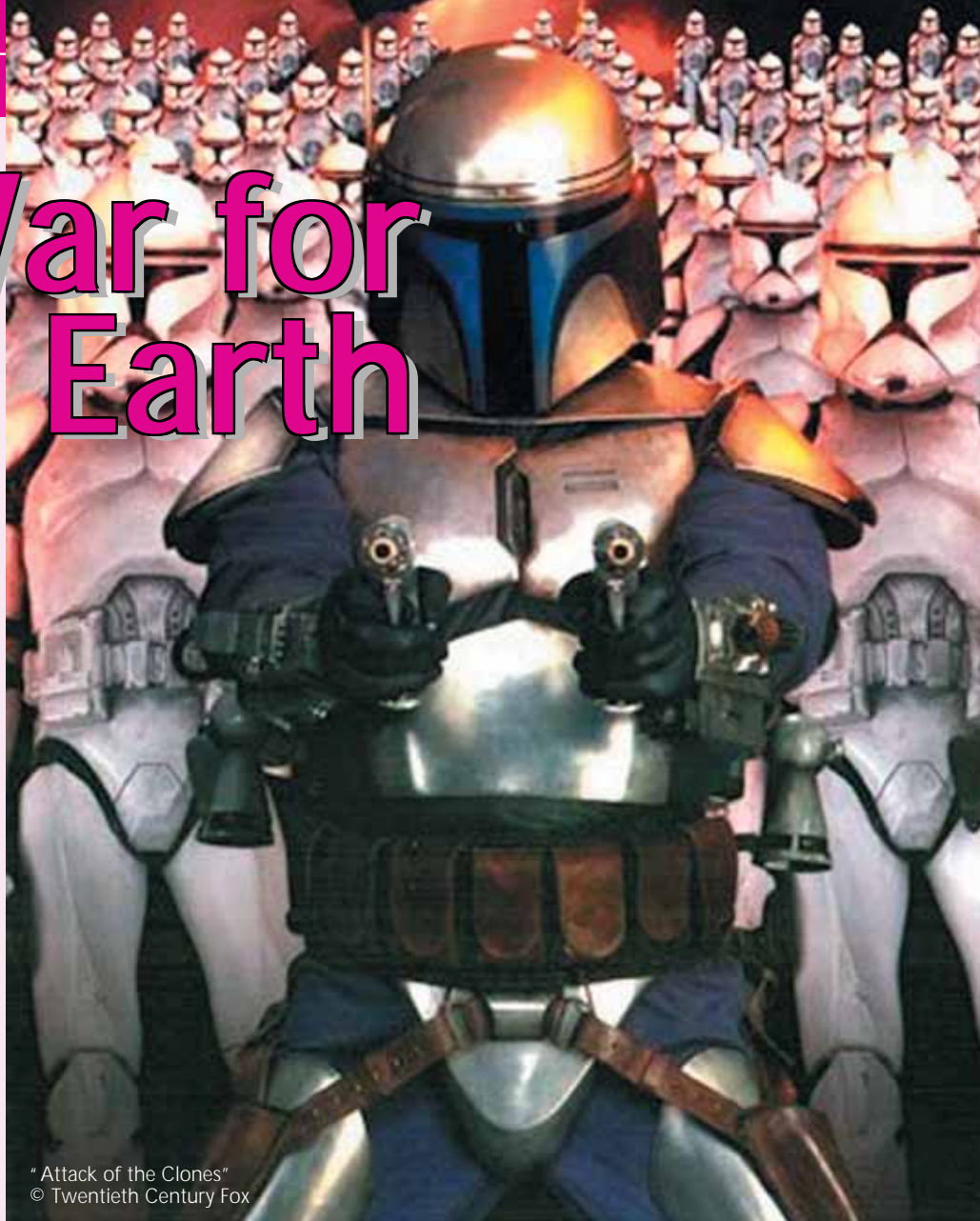

“Attack of the Clones”
© Twentieth Century Fox

extraterrestrials to impose a fascist dictatorship of the entire planet, under their control. If that is the case it appears that the planning may have begun in the early years of the 20th century, and that Hitler’s rise to power was coordinated with Mussolini’s in Italy and the emergence of Hideki Tojo in Japan. Such a scenario would help to explain many strange similarities between the three fascist movements, especially the militarization of the governments, and the imposition of elaborate and sophisticated propaganda machines. Propaganda, after all, is nothing more than a form of national mind control, and we suspect that the aliens are very skilled in these techniques.

Cloned Storm Troopers?

At the close of World War I in 1919, under the terms of the Versailles Treaty, Germany was allowed to keep only 100,000 men in the army and 15,000 in the navy. They were not permitted to have submarines or military aircraft. This situation remained ba-

sically stable for the next 14 years until Hitler came to power in 1933 and then, in March of 1935, instituted conscription and renewed military training in open violation of the treaty. To achieve the extravagantly ambitious goal of world conquest, Germany would need a bright new army of young, ruthless, efficient, well-trained storm troopers numbering in the millions. In 1933 that seemed like an impossible dream, since the army then consisted mainly of 100,000 aging, dispirited veterans of WWI, and some raw recruits. It seemed especially hopeless in view of the depressed economic conditions in Germany at that time. Yet, in September of the very next year, six months before conscription began, at the Nuremberg Nazi Rally of 1934, 160,000 stalwart German soldiers with backpacks and rifles stood silently at attention in precise ranks as Hitler, Heinrich Himmler and SA chief Viktor Lutze walked down the wide center aisle towards flaming

Continued on Page 65

FORBIDDEN RELIGION

Suppressed Heresies of the West

Edited by J. DOUGLAS KENYON

Following the model of his bestselling *Forbidden History*, J. Douglas Kenyon has assembled material that explores the hidden path of the religions banned by the orthodox Church—from the time before Christ when the foundations of Christianity were being laid to the tumultuous times of the Cathars and Templars and the Masons of the New World. Revealed are the intimate ties of ancient Egyptian religion to Christianity, the true identities of the three magi, the link forged by the Templars between early Christianity and the Masons, and how these hidden religious currents still influence the modern world.

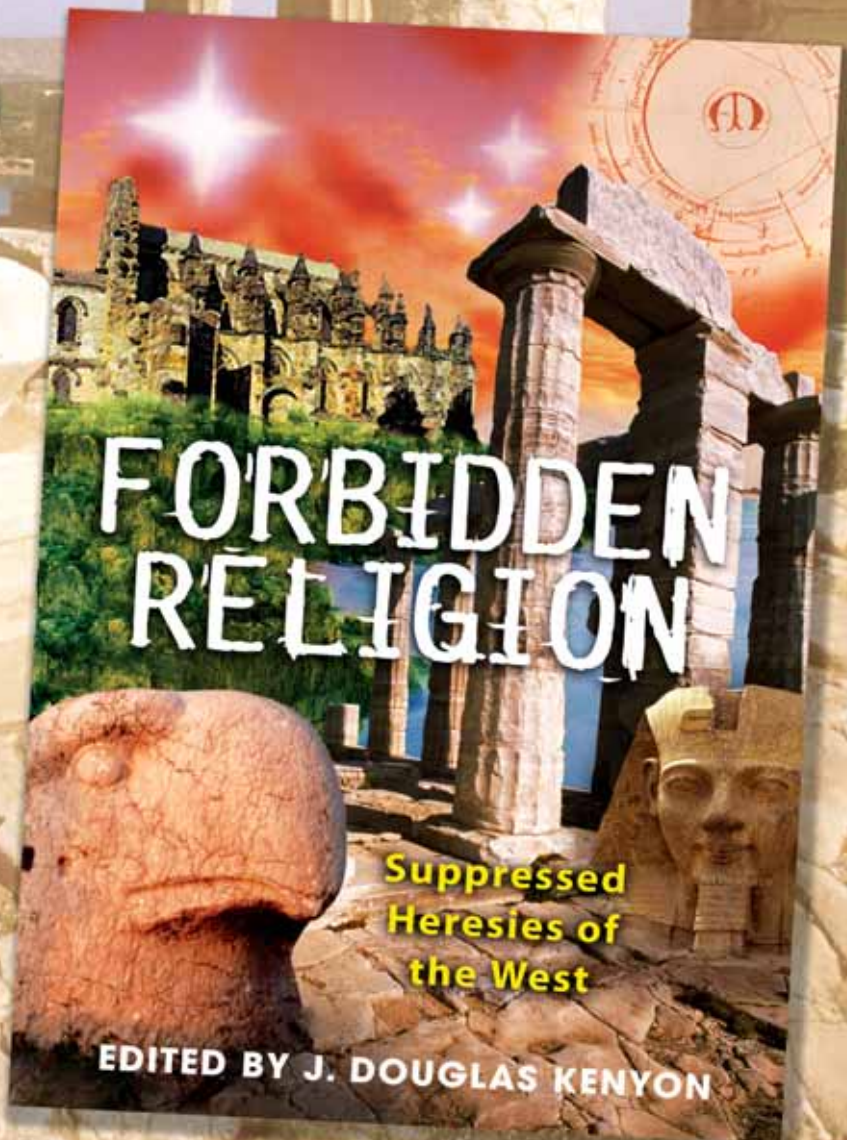

To Order Call
800-228-8381

\$18.00, paper, 336 pages, 6 x 9
Includes 16-page color insert and 100 b&w illustrations
ISBN 1-59143-067-4
+ \$5.95 S.&H.



INNER TRADITIONS
BEAR & COMPANY



For these and other great titles visit us at www.InnerTraditions.com • 800-246-8648

Quebec's Curious Hammer

• BY FRANK JOSEPH

In 1964, archaeologist Thomas E. Lee was scouting near an excavation under way near the village of Imaha, in northern Quebec, when he found a tall, curious monument on the desolate north bank of the Payne Estuary, 15 miles above the village of Payne Bay, near the west coast of Ungava Bay. The two-ton stone structure stands 8 feet high and measures 4-1/2 feet across at its pointed lintel, surmounted by a 14-inch-high capstone. While the pillar was a surprise to Lee and his colleagues, he later learned from the native Inuit that they had known of it for generations. Yet, they laid no claim to it, insisting that the strange object was already standing long before the first of their ancestors arrived in the area. Moreover, the Inuit never worked in stone on such a large scale.

Lee was struck by its roughly Nordic design and dubbed it "the Hammer of Thor." The stone structure might also be a direction indicator, because it appears to point toward the remains of a rectangular stone structure (80 feet long and 30 feet across) not far away. The outline of slanting walls half-buried in the hard ground resemble a Viking long-house from the 10th or 11th centuries. Greenland is not very far from this point in Quebec, so Norse visitors 1,000 years ago could have sailed the distance in their sturdy dragon-ships and left a memorial to their arrival.

Lee's characterization of the Ungava Bay object as a "Hammer of Thor" does not seem inappropriate. Similar stone structures appeared throughout Viking Age Scandinavia; the Temple of Thor in Sweden dates before 1125. We know that Nordic seafarers voyaged at least as far as Newfoundland and that they certainly did not lack ships to bring them to Quebec from relatively nearby Greenland. Thor's hammer was the most commonly reproduced religious object of the period. It was known as Mjollnir, and was envisioned as the lightning, as it flew from the storm-god's hand. He was the patron deity of fertility, but also of courage and decisive action.

Thor was portrayed in saga and art as a middle-aged man of great strength, with long, red hair and beard. He was sometimes shown being carried across the universe in a great chariot drawn by rams. The 1,000-year-old Quebec monument was probably set up to call upon his strength of will in a difficult

Tracking Canada's Mysterious Origins

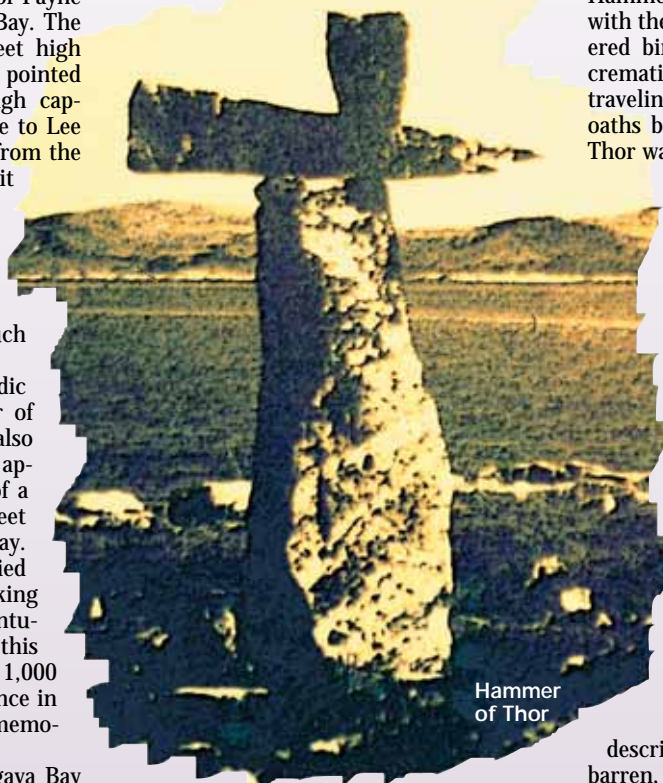

Hammer of Thor

land. Interestingly, a bronze statuette from Northern Iceland (National Museum of Iceland, Reykjavik) of Thor with his hammer, circa 1000, portrays him wearing a conical hat virtually identical to the headgear worn by male figures depicted at the white stone of Ontario's Petroglyph Provincial Park.

Mjollnir was not merely a symbol for meteorological events, however. The gods of Valhalla (the Aesir) proclaimed it the single most valuable object they possessed, and its likeness appears to have been reproduced by Viking shamans to hallow marriage rites, to bless the recently departed souls of the dead at funerals and to consecrate newborns into the community. Mjollnir's image was inscribed on a Swedish tombstone at Stenqvista. It thus resembles a higher symbol of the birth-death duality not unlike the sacred Double-Headed Axe of the Bronze Age, par-

ticularly as realized in Minoan Crete. In a particularly revealing myth of Thor and his Hammer, he restores the dead to life through the potency of its magic.

As the Norse specialist, Ellen Davidson, writes, "It would seem indeed as though the power of the thunder-god, symbolized by his Hammer, extended over all that had to do with the well-being of the community. It covered birth, marriage and death; burial and cremation ceremonies; and feasting; traveling; land-taking and the making of oaths between men. The famous weapon of Thor was not only the symbol of the destructive power of the storm and of fire from heaven, but also a protection against the forces of evil and violence."

But "Thor's Hammer" is not the only stone structure of its kind in Canada. During August 1972, Dawn French took up residence in the small town of Pushthrough, an outpost thirty miles west of Bay du Nord, on the south coast of the island of Newfoundland. While there, she heard strange tales of the legendary Stone Cross, a structure supposedly venerated by the local Micmac Indians for centuries before the arrival of modern European immigrants. No one had actually seen it and its whereabouts were unknown.

Curious to learn more, French studied the native traditions, which described a sacred precinct, lonely and barren, where people in need of healing would find a large, unusually shaped cross spread out on the ground. It was the site of supposedly miraculous cures, but, over time, with the advent of the white man's medicine, the place was abandoned to myth.

The Micmacs are an interesting people. Their name means "Allies," a reference to the confederacy of clans they formed and led, thus becoming the largest and most important native tribe in Canada's eastern Maritime Provinces. A seasonally nomadic people, the Micmacs' Algonkian dialect differs greatly from that of their neighbors, and has some suggestion of Scandinavian cognates. Their possible linguistic links to Medieval Europe are underscored by what appear to be Nordic recessive gene traits among the Micmac (recurring blondness) and especially by the discovery at the island's northern extreme of

Continued on Page 68

Editor's Comment

In the first eighteen issues of *Atlantis Rising* we serialized, in graphic novel style a story called *The Atlantis Dimension*. Based on a screenplay originally written in the early 1980s by editor Doug Kenyon (in collaboration with artist Tom Miller), the story recounted the adventures of a group of contemporary characters who discover the ruins of Atlantis beneath the waters of the so-called Bermuda triangle. The action is driven by ancient events on Atlantis which unfold in the lives of the principal characters today, who are, in fact, Atlanteans reincarnated. There is plenty of action, ancient technology, underwater archaeology, treachery in high places, and nature turned very bad.

Long since those early issues, this publication has established an identity transcending the themes of that story, but it is possible that, had we not originally chosen to publish that screenplay, *Atlantis Rising* magazine might not have been even launched. It should surprise no one, then, that we continue to emphasize the possibility of underwater Atlantean remains in the Bermuda triangle.

Over the years, we have watched for developments which reinforce the plausibility of our scenario, and there have been more than a few. Even the building of the world famous Atlantis resort on Paradise Island in the Bahamas echoes a key story element of ours written over ten years before the fact. The name Paradise island, for example, was used in connection with a similar Bahamas resort development, in what we thought at the time was an entirely fictitious way.

For most who follow the subject of Atlantis in the Bahamas, though, the story focusses on the famous prophecy by Edgar Cayce, made in the 1920s, that the ruins of Atlantis would ultimately be rediscovered in the Bahamas. We could, he declared, expect the reappearance to begin in the late 1960s. When University of Miami scientist Dr. Manson Valentine located an apparent underwater pavement near Bimini in 1968 the Cayce prophecy made headlines. In the ensuing excitement researchers and media types from all over the world flocked to the area. The hoopla was short-lived though. The "experts" soon pronounced the "Bimini Road" nothing more than ordinary "beachrock," hardly worth a second look. Very soon, anybody who dared to treat Valentine's discovery, or Cayce's prophecy, seriously was laughed off the stage. And there the matter has been put to rest.

Or has it?

As regular readers of this magazine know, archaeologists Drs. Greg and Lora Little, William Donato and other researchers working primarily on behalf of the Association for Research and Enlightenment (A.R.E.), the Virginia-Beach-based Edgar Cayce organization, have continued to track the evidence, wherever it might lead, and

LOST CIVILIZATION & the Bermuda Triangle

Are New Discoveries at Andros Island and Elsewhere, the Smoking Gun for Prediluvian Civilization?

have produced some startling results. Not the least of their discoveries is that the so-called debunking of the Bimini Road discovery is itself a virtual hoax. Greg Little reported the entire matter in AR #57 (See "Exposing a 'Skeptical' Hoax"). In their considerable studies the Littles have turned up extensive evidence that the location once served as a busy seaport, and did so long before sea levels approached their present height—in other words, thousands of years before humans are believed to have been capable of such highly organized effort. Moreover, Greg Little demonstrates, conclusively, that the conventional view, usually presented in the media, is based upon many false representations of the actual facts.

The significance of the Bimini Road discovery—establishing as it does the existence

of anomalous prediluvian civilization—is difficult to overstate. That, however, is, apparently, only the beginning of the story. The Littles and their associates have continued to bring to light many astonishing artifacts throughout the area, particularly at Andros island which are throwing conventional thought, if not into the trash heap of history, into, at the very least, confusion.

The following report filed with *Atlantis Rising* by Greg Little summarizes the latest work:

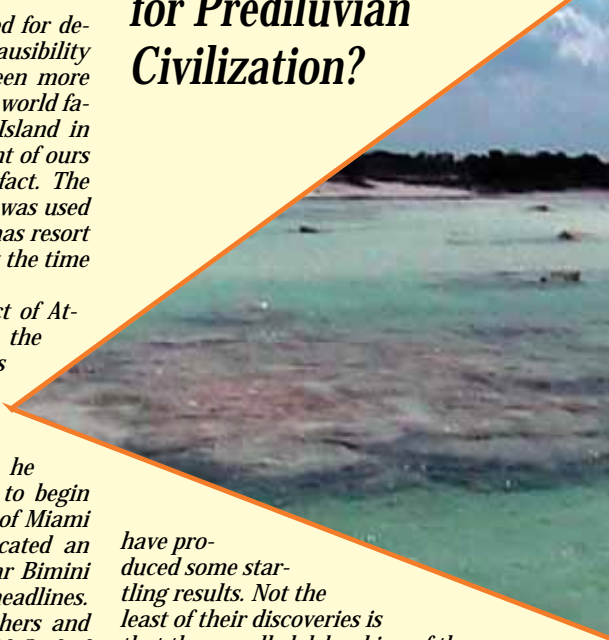

• BY DR. GREG LITTLE

November 2006—Bimini Side-Scan Sonar Project

A November 2006 expedition conducted a side-scan sonar and sub-bottom profiling project at Bimini utilizing an underwater exploration company. Archaeologist Bill Donato organized and conducted this project with support from the A.R.E. The side-scan sonar off west Bimini was done in a large rectangular area roughly two by five miles. The computer-assisted sonar yields bottom images that are similar to an aerial photograph showing contours and details of whatever may be on the bottom. While sunken ships, cargo, and unusual formations were found by this huge project, one finding, in particular, caught Donato's attention. It was a series of uniform, consistently oriented, rectangular structures at a depth of 100 feet. Over a dozen of these building-sized formations were found by the sonar. They ranged in size from 5-20 feet by 10-25 feet. An effort was immediately made to dive to these sites; however, strong bottom currents made reaching them impossible. It is now known that the sea levels at Bimini in 10,000 B.C. were about 110 feet lower than today, so the presence of these rectangular formations at 100 feet was intriguing, to say the least. (Note that these were re-found and inspected in June 2007, which is described later.)

May 2007—Andros Exploration

Drs. Greg & Lora Little made a weeklong expedition in May to North Andros with Bahamas' boat/dive operators Krista and Eslie Brown. The purpose of this trip was to conduct a wide, systematic survey of the Great Bahama Bank and explore the small islands just north of Andros. An aerial survey of a portion of the Great Bahama Bank was taken on the way to Andros to locate several intriguing dark features that had been previously seen from the air, but never directly investigated. Several of these features were found and the GPS coordinates of them were taken by the plane. All of these were then visited by boat.

Findings at underwater dark features on the Great Bahama Bank

One of the most

interesting dark features found on the Bahama Bank, dubbed the "tee and ball" by Lora Little, consisted of a several-hundred-foot-long dark formation shaped like a massive golf tee with a round dark "ball" at its top. It is located about 25 miles offshore. Found in an area where the seabed is white sand, the black formation on the bottom is formed primarily from dense turtle grass. These grassy areas are heavily populated by a wide variety of fish, turtles, and sharks. The "ball" next to the "tee" had a boat trailer dumped in it along with several huge tires. This type of dumping is done by Bahamas' fishermen to increase the cover for fish. However, the long "tee" consisted of a line of scattered stone blocks, which allowed the buildup of turtle grass. The blocks are far too large for ship ballast and were not dumped into piles. All of the dark features on the Great Bahama Bank are in depths of 20-30 feet of water.

Two other dark formations on the Bank were also found to be formed from stone slabs. These also were far too large to be ballast stone for ships; however, all of them, including some that were elevated into large "piles," were covered by a considerable amount of sand. More investigations of these dark features on the Great Bahama Bank are described later.

Andros Shoreline Investigations

Several miles of the shallow shoreline along North Andros were examined with a remote underwater video camera pulled by a cable on the boat. This revealed an area where massive slabs of stone were found to be lying on the bottom just off 50-foot-high sheer stone cliffs that are pounded by wave action coming off the deep "Tongue of the Ocean" trench running along east Andros.

A series of land expeditions, conducted with descendants of Seminole Indians who fled to the Red Bays area of Andros starting in the 1820s, were made. A curious dolmen-like formation was found in the pine jungle several miles from Red Bays. About a dozen caves, some of them quite large and deep, were explored. In addition, we became interested in three crashed plane remains we found. This is also described in a later section.

Discovery of the underwater "Joulter's Wall"

Numerous interviews with local residents of Andros were made. One resident told us about a huge, underwater wall that was located in shallow water on the small chain of islands known as Joulter's Cays, about 7 miles North of Andros. Joulter's is completely uninhabited, and data obtained during the past 20 years has shown that

Continued on Page 70



(Clockwise)
Joulter Wall. Crashed DC-3 on Andros. "Tee and ball" formation. Underwater wall at Joulter's. One of the smallest blocks from the Joulter's wall, removed from beneath larger blocks. Mysterious 500-foot-long dark feature on the Great Bahama Bank.



Ken Eagle Feather

Getting the Dream Thing Right

Ken Eagle Feather Thinks We Can Do a Lot Better

• BY CYNTHIA LOGAN

Right off the bat, Ken Eagle Feather tells me he's not Native American, but is "white as wonder bread." The name was given to him by don Juan Matus, the same don Juan encountered by Carlos Castaneda of *The Teachings of Don Juan, A Separate Reality and Journey to Ixtlan* fame. He had it legally changed in the 1970s, during the time he was actively engaged with the controversial figure. "The argument as to whether don Juan is or was a real person has spilled over into academia big time," states Eagle Feather. Claims that Castaneda himself was a fraud and that his Ph.D. in anthropology from UCLA had been revoked were put to rest when Eagle Feather telephoned the university, which assured him the bestowal is still intact. His own opinion is that Castaneda may well have been "the Copernicus of our time."

Self-described as "a silver-haired rascal," Eagle Feather asserts that he met and was apprenticed to don Juan, and that he was given the instruction to study Castaneda's books ("they contain a sophisticated worldview to focus energy, as well as disciplines and techniques to harness energy") and present the Toltec teachings within them from a different perspective. He spent 16 years poring daily over the material, adding another two years of intermittent study that included other esoteric writings and the world's sacred texts. Eagle Feather's first book, *Traveling with Power*, explained his encounter with don Juan and basics about the path revealed. His second, *A Toltec Path* (republished ten years later as *On the Toltec Path*) describes the overall structure of don Juan's teachings. He then wrote *Tracking Freedom* "for good measure, to consolidate and synthesize Toltec teachings with other systems of learning."

Since Eagle Feather feels he has moved beyond that identity ("Ken Eagle Feather has flown away") and is now writing under his given name, Ken Smith, let's call this fifty-something author 'Smith' from here on. It's easy, and reflects the man's focus on

conveying his understanding to the ordinary person. "And how ordinary can you get?" he asks, chuckling at the simplicity of his 'new' name. In an upcoming title, he'll do away with the somewhat cumbersome terminology in his current book, *Toltec Dreaming*, which illuminates don Juan's teachings on the 'energy body'. A hefty topic, admits Smith, who says the energy body includes not only the physical [body] but all the various "bodies" thought to exist in other traditions. "While the Taoists gave us the meridian system and yogis developed the chakra model, this concept and the mapping out of its anatomy is the unique contribution of the Toltecs." (The Toltecs are thought to have ruled central Mexico between 3,000 - 7000 years ago. Though masterful in the control of energy, the old order grossly misused such abilities.) According to Smith, Castaneda built a bridge between the old and modern (circa mid-1700s C.E.) lineages. "Don Juan is part of a specific line dating to 1723 and is dedicated to using extraordinary capabilities only for positive purposes. He also thinks drugs warp personal energy and should be used rarely, with caution and reverence, and only if meditative exercises fail."

The whole gig of being human, according to don Juan, is that we are luminous creatures. As such, our natural function is that of being aware, of perceiving. "The metaphysical philosophy known as the Toltec Way deals with the nature of reality, including how reality is perceived, formulated and experienced," writes Smith. "Its philosophy of action and behavior superimposes on the waking world the subtle physics of the dream world in order to create a conscious dreaming body that, when fully realized, can act as a vehicle to higher consciousness."

The energy (dreaming) body has eight cornerstones of perception which, when diagrammed look somewhat like the Kabbalist Tree of Life. Realities are created and congealed as patterns (termed 'cohesions' by Smith) within this body. Often culturally constructed, a particular reality determines what you think

Continued on Page 72

Atlantis Rising PDFs on CD!

Own the first five! Hard-to-find issues with click-&-go interactive features & exclusive specials & bonuses.



Collect all five—each with a whole year (6 issues) of *Atlantis Rising* on CD in PDF format. View and print the magazine (just the way it appears in print) with Adobe Acrobat Reader, available FREE from Adobe.com. Plus, these PDFs have been OPTIMIZED with interactive features for quick-and-easy navigation in and around the magazine, including:

- BOOKMARKS take you directly to articles or sections you are interested in.
- Click on any article in the CONTENTS to go directly to it.
- Featured ADS (with RED BORDERS) have links that take you directly to their website.
- Many stories posted in the iNEWS section are linked directly to their Internet source.
- Click on the CATALOG footer to go to our catalog section.
- Click on the bar at the bottom of the catalog to get to the interactive ORDER FORM.

BONUSES: ISSUE #1 AND POSTER-QUALITY FILES OF TOM MILLER'S AWESOME PAINTINGS!



2002 Issues #31-36
+ Special Bonus: Cover Art from Issue #5 by Tom Miller, "*Ghost of the Templar*"
JUST \$19.95 + S&H



2003 Issues #37-42
+ Special Bonus: Cover Art from Issue #7 by Tom Miller, "*Atlantis in Antarctica*"
JUST \$19.95 + S&H



2004 Issues #43-48
+ Special Bonus: Issue #1 *Our First Issue!* Sold out for 5 years...worth \$70!
JUST \$19.95 + S&H

2005 Issues #49-54
+ Special Bonus: Cover Art from Issue #6 by Tom Miller, "*Atlantean Asteroid*"
JUST \$19.95 + S&H



2006 Issues #55-60
+ Special Bonus: Cover Art from Issue #4 by Tom Miller, "*Impossible Inventors*"
JUST \$19.95 + S&H



Order all five and save!
SPECIAL PACKAGE PRICE
JUST \$85.75 + S&H



PC & Mac Compatible

Send check or money order:
ATLANTIS RISING
P.O. Box 441
Livingston, MT 59047
Call 800-228-8381
Shipping & handling: \$4.95 first item,
\$2 each additional. (Set of 3 = 1 item)

H. G. WELLS and NEAR-DEATH EXPERIENCE

Did the Great Science-Fiction Writer Know More about Such Things than He Would Let On?

• BY JOHN CHAMBERS

“She was not clear whether it was night or day nor where she was; she made a second effort, wincing and groaning, and turned over and got in a sitting position and looked about her.... She seemed to be in a strange world, a soundless, ruinous world, a world of heaped broken things. And it was lit—and somehow this seemed more familiar to her mind than any other fact about her—by a flickering, purplish-crimson light.”

This isn't a description, by a Japanese survivor, of the atomic bomb exploding over Hiroshima in August 1945, though it sounds like one.

Rather, it's a description, by a French soldier, of a German atomic bomb exploding over the Eiffel Tower in Paris in the late twentieth century.

The description appears in *The Last War: A World Set Free*, a novel published by founder of science-fiction H. G. Wells in 1913. In *The Last War* Wells also provides a detailed description of an artificially induced chain reaction, calling this process a “disease of matter.” Not until the early 1930s did any scientist think such a thing might be possible.

In *The War in the Air*, a novel published in 1908, the English novelist/social prophet had proven equally prescient. The novel describes a surprise air attack on Manhattan. Wells sets forth the disposition of the enemy powers as it actually would be during the Second World War: the Japanese rule the Pacific, while the Germans conquer Europe under the leadership of a charismatic fanatic who is half Napoleon, half “Nietzsche's Overman revealed.”

The farther in time we get from H. G. Wells (1866-1945), the more uncannily pro-

phetic he seems. Certainly not all his imaginings have come true. There has been no invasion from Mars (*The War of the Worlds*, 1898), nor have there been any feats of time travel (*The Time Machine*, 1894-95) that we know of. But scattered here and there throughout Wells's many novels, short stories and essays are astonishingly apt descriptions, not only of events that would come to pass, but of speculative ideas that would catch fire only many decades later.

In the short story *The Man Who Could Work Miracles* (1898), the actions of the eponymous narrator dramatize the notion, first popularized by medium Jane Roberts's in her 1970s Seth books, that “our thoughts create reality.” They also make real the concept, vividly fleshed out in the *Back to the Future* movie trilogy of the 1980s, that if we were to travel back to the past we would change the present and the future. The hero of *The Man Who Could Work Miracles* discovers he can make anything happen and create any object simply by wishing it so. He begins with minor feats like materializing a rose. He soon becomes involved in righting social injustices. Eventually he gets so carried away that he doesn't want the day to end and inadvertently wishes that the earth would stop rotating on its axis. He gets his wish—and momentum tears everything movable off our planet's surface, carrying the debris forward in a cataclysm of destruction.

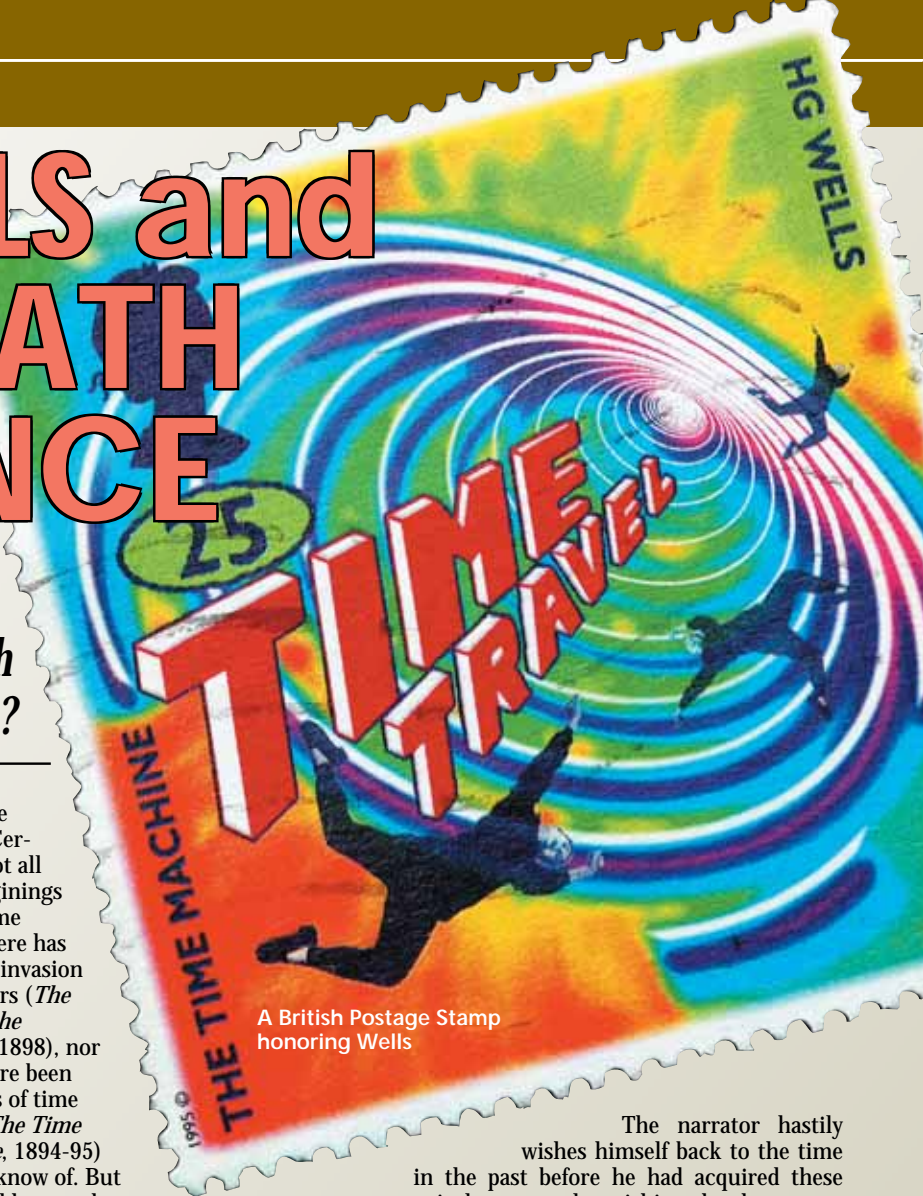

A British Postage Stamp
honoring Wells

The narrator hastily wishes himself back to the time in the past before he had acquired these magical powers, also wishing that he not acquired them and that he forget he ever had. All this happens, and as the story ends the earth is moving forward on its calm and customary path.

How was Wells able to be so amazingly accurate in so many of his predictions?

The startling answer may be that he actually had seen the future.

Herbert George Wells was born into a working-class family in Bromley, Kent, so poor it seemed unlikely Wells would ever even qualify for college. At age 14 he was apprenticed to a draper; he despised this and broke away, attending night school and becoming a teacher's assistant at The Holt Academy in Wrexham, Wales. Eventually, Wells would receive a scholarship to study biology, attend lectures in London, and in 1888 acquire a college degree in science, thus paving the way for a brilliant career as a writer. But it was while he was at Holt, in 1886, just before his twenty-first birthday, that something may have happened to the future writer that changed, more radically than any sojourn at a college, the entire future course of his life.

Wells tells us in his *Experiment in Autobiography* (1934) that he was playing football

with some students early on in his stay at Holt when one of them threw him roughly to the ground. Wells managed to get up, but felt very ill and had a terrible pain in his side. He staggered off the field and somehow made it back to his room. He writes:

"In the house I was violently sick. I went to lie down. Then I was moved to urinate and found myself staring at a chamber pot half full of scarlet blood. That was the most dismaying moment in my life. I did not know

what to do. I lay down again and waited for someone to come." Wells seems to have lost consciousness for the next few hours. "Nothing very much was done about me that evening, but in the night I was crawling along the bedroom on all fours, delirious, seeking water to drink. The next day a doctor was brought from Wrexham. He discovered that my left kidney had been crushed."

No one expected H. G. Wells to live. But the future author, languishing in bed for many days, finally began to recover. He returned to work, but started coughing blood again. Tuberculosis was diagnosed. This disease, and its complications, was to dog him for the rest of his life.

During the first days of his illness—when he almost died—did Wells have a near-death experience that revealed the future to him?

Nowhere in all of his voluminous writings does he tell us that anything of the sort happened. But Wells wrote two short stories that seem to describe near-death experiences, the second in startling detail.

In *The Truth in the Light: An Investigation of Over 300 Near-Death Experiences* (Berkeley Books, 1995), authors Dr. Peter and Elizabeth Fenwick polled several hundred near-

death experiencers (NDErs) to find out what happened after they got beyond the experiences of the white light and the glowing tunnel. One quarter of the responders said they had been "left standing at the entrance [to the afterworld], but prevented from going in by some kind of barrier, a point of no return." Sometimes the barrier was psychological; other times it was physical, such as the "low green trellis fence," reported in one case, or the "wrought-iron gate—a tall church window-shaped gate," reported in another.

The other-worldly entities on the other side of the barrier often appeared in groups of three. One responder encountered three "young Indian men...young Indian princes, or rajas;" another stood before "three old Chinese men who all had long white beards and who also wore white robes." Often only the middle entity faced the experiencer directly.

The Fenwicks found that the well-known NDE "life review" often contained tantalizing glimpses of the experiencer's future. One interviewee, arriving at a church, observed "two large trestles, each with a book resting on them." A spirit guide flicked through the pages, which were blank, then stated: "This will be your life if you go back." The empty pages suddenly filled up. Though conflicted by what he saw, the responder decided he had no choice but to return to life.

In 1995, the same years as the Fenwicks

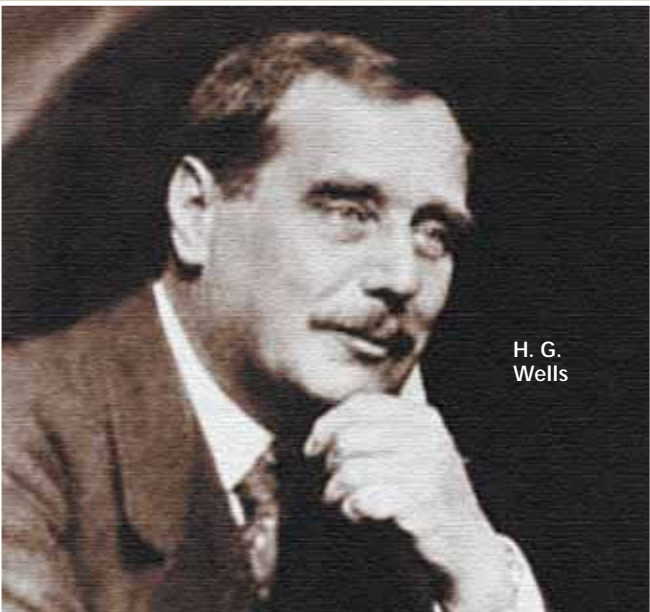

H. G. Wells

Continued on Page 73

MAKE A CHANGE IN YOUR LIFE AND IN THE WORLD

Learn how to help yourself and others be healthy in body, mind & spirit.

The American Institute of Holistic Theology offers accredited nonsecular college degree programs through self-paced home study. You can earn your advanced degree in:

- Holistic Ministries
- Holistic Health
- Divinity
- Metaphysics
- Parapsychic Science

Learn how to build and maintain a private health practice teaching the universal laws of health and healing.

For a free catalog, call **1-800-949-HEAL (4325)** or **www.aiht.edu**



ACCREDITED MEMBER:
The American Association
of Drugless Practitioners
Certification & Accreditation Board

Saturn in Virgo

The Lord of the Rings Enters the Realm of the Celestial Virgin



*"To put the world in order, we must first put the nation in order;
to put the nation in order we must put the family in order;
to put the family in order, we must cultivate our personal life;
and to cultivate our personal life, we must first set our hearts right."*

Confucius

• BY JULIE GILLENTE

The ringed planet Saturn entered the sign of Virgo on September 2 and will transit through the sign of the celestial virgin until July 2010, nearly three years. Virgo is the only female among the zodiacal constellations, and other than the twins, Castor and Pollux (Gemini), she is the only human figure. Virgo is depicted as a maiden, holding a palm branch in her right and a single ear of wheat in her left. Her brightest star is named Spica, "ear of wheat." Virgo is one of the oldest constellations and over time has been equated with every important feminine deity, including Ishtar, Isis, Demeter, Persephone, Medusa, Artemis, and Urania. Richard Hinkley-Allen says, "Those who claim very high antiquity for the zodiacal signs (15,000 years ago), assert that the idea of these titles originated when the Sun was in Virgo at the spring equinox, the time of the Egyptian harvest."

Australian astrologer Bernadette Brady has remarked that "Whatever image is chosen across time and cultures, what is contained in Virgo is the archetype of the harvest-bringing goddess, pure and good, independent of the masculine. She gives the four seasons and is the source of the fertile Earth." The more ancient concept of "virgin" described a woman who was independent and free to love whom she chose. Virgo is also the Greek Sophia, goddess of wisdom, and in the Gnostic tradition, she is the Black Madonna, mysterious guardian of feminine wisdom.

The power of these goddesses, ranging from agriculture and astronomy to justice, wisdom and war, seems to be missing from typical astrological renderings of the sixth sign of the zodiac. Virgo is often described as analytical, critical, narrow, timid and tentative. Virgo is introspective and analytical, always seeking perfection. In modern parlance we might understand Virgo's path as one of coming into the fullness of power, claiming and expressing what exists in potential.

The mutable earth sign Virgo relates to the spiritual stage of spiritual unfolding which focuses on specialization of forms. She

represents the stage in the cycle when the soul's experience is focused on assimilation of knowledge. In this phase matter is organized, purified and refined into specific and recognizable objects. Here we might say the Grand Plan of the Cosmos is carried out in detail. The Zodiac has also been said to represent the body of the Macrocosm, the Grand Human. In this vein the first sign Aries corresponds with the head, Taurus the neck and shoulders, and so on. Metaphysically Virgo is the matrix and represents the womb of the inner Christos, or spiritual self, containing the seed and eventual fruits of the Spirit. Seeds germinate in darkness, breaking their way out of their shell casings, and sending roots into the Earth. Like the abdomen and intestines which Virgo has dominion over, this phase distills the qualitative pearls from life.

Saturn

The ringed planet orbits the sun in 29.5 years so Saturn spends roughly 2.5 years in each sign. Due to vagaries of the planets' motions this is not consistent and Saturn will spend closer to three years in the sign of Virgo. For individuals every 29.5 years Saturn returns to the place it occupied at birth. This is called a Saturn "return" and this event is always profound, usually bringing change in the circumstances of life.

Myth transmits archetypal knowledge through stories and symbolism, but archetypes are complex and sometimes these stories seem contradictory. Saturn's myths are a good example. Saturn is an old Italian god who is identified with the earlier Greek Cronus, Chief of the Titans, one of the great figures of myth. One tradition portrays Cronus as a selfish and autocratic ruler, intending to maintain his reign at any cost. In an act which is a nasty abuse of power even by mythical standards Cronus swallowed his own children so that none of them would supplant him. His wife Rhea, herself a very ancient pre-Hellenic goddess from Crete, ultimately foiled this arrogant attempt by giving him a swaddled stone instead of his last-born Zeus (Jupiter). Subsequently, Jupiter tricked Cronus into coughing up the rest of his siblings.

In Orphic cosmology, however, which traces its roots to Egypt, Cronus was seen as a beneficent king, ruling over both heaven and earth. In this guise Cronus ruled during a halcyon golden age in antiquity. Cronus is also sometimes identified with Chronus, who is not depicted as a personified being, but rather as Time itself, which of course does

swallow all of its children in due course. A deeper interpretation of this interwoven symbolism might be that attainment of the "stone of the wise," shown by swallowing the stone which he thought was Jupiter (Wisdom), finally liberating our consciousness from the wheel of time.

Nature of Order

Astrologically Saturn is still seen as lord of time, and when he connects to points in our horoscopes we feel his heavy hand. In astrology Saturn's influence is the embodiment of form, and the dramatic rings which surround the physical planet represent the idea of limitation. He is sometimes depicted as the Grim Reaper, wielding a scythe, and cutting a wide swath in human affairs. The reaper is only "grim" if we have sowed metaphorical seeds of destruction. Saturn is often viewed in a dim light, but it is our veiled and incomplete understanding of the nature of how consciousness partakes in the creation of reality that is the problem with his reputation.

Not only is Saturn famous for its spectacular rings but another geometric feature of the planet puzzles scientists. Saturn has a bizarre hexagon-shaped cloud which circles the north pole of the ringed planet. Scientists are stumped by this geometric cloud formation. Originally discovered by Voyager in the 1980s nothing like this phenomenon has been observed anywhere else in the solar system. It's intriguing that such an enigma, along with the most dramatic rings, should appear on the planet which astrologically symbolizes form and structure. Pythagorus is quoted as saying, "God geometrizes," and one wonders what message from Nature is contained in this conundrum.

The influence of Saturn by sign serves to limit or control circumstances in our lives and can also indicate how we will be limited, controlled, frustrated or delayed by what seems to be the cruel hand of fate, according to the sign Saturn transits. The ringed planet gives form to our life experiences and therefore provides our lessons. We can learn from this transit by perceiving how our critical instruction presents itself whether through people or experiences. With the benefit of hindsight most of us give credit for our most profound lessons to our toughest teachers. We look back in gratitude to those who expected the most from us or held our feet to the proverbial fire. Saturn is at heart a wise teacher if seeming to be a stern taskmaster. When we are truly wise we understand that Saturn plays the role of tough-love teacher. If we accept his lessons we are invariably strengthened in character.

Saturn represents how we have structured our reality through our thoughts, and in a quantum sense Saturn represents the way we perceive reality as our individual and collective conscious has created and structured it. This is not really an external process although it seems to be outer events that provide the classroom.

Ringling in the Sheaves

With Saturn in Virgo the character is in-

clined to be upright in nature and industrious with a risk of rigidity or a too-critical nature. There is a tendency to be overly serious and always see the glass as half empty. This combination of energies dislikes uncertainty and can lack faith. Self-confidence is not strong with Saturn in Virgo. Saturn in Virgo tends to avoid risk and speculation, preferring to have all the facts and figures, so a lively stock market is not likely during this transit. Some see the big picture in a macro fashion while others, like Virgo, look through a microscope and are more qualified to execute the fine points. Both perspectives are necessary, but with Saturn in Virgo there is a tendency to worry over details that are inconsequential and fail to see the big picture. As the old adage says, "The devil's in the details" whether we ignore them at our peril or pay too much attention to them and miss the boat entirely.

Saturn in Virgo engenders a keen sense of discrimination and analysis along with a strong scientific bent. A healthy dose of

common sense is a positive attribute. Saturn in Virgo does not take things at face value. In a natal chart and by transit this placement favors researchers and scientists. A sense of overwhelming responsibility can characterize Saturn in Virgo. With this transit or natal combination efficiency and thoroughness are more important than speed and sparkle. This transit is a good time to focus on health and put behaviors and structures in place to improve overall fitness.

Saturn is the planet of form and order and Virgo is the sign which pulls us toward an illusory quest for perfection, so it's fair to say that this combination creates a quest for perfection in form that is doomed before it begins. Perfection is an abstract principle which by its nature is not really attainable in the world of form. Virgo's more ancient and powerful side is associated with ancient goddesses of grain and the cycles of the year. Saturn's is related to cycles of time in a karmic or philosophical manner in that what we sow we eventually reap. Time heals all things but time also ultimately brings the chickens home to roost. This is a nose-to-the-grindstone combination of energies where practical application in the present will yield a rich harvest later.

In due time

Pluto will go direct in motion in early September at 26 degrees at the same time Saturn enters Virgo, moving forward potentially powerful

energies for transformation and contributing an auspicious boost to Saturn's tenure in the sixth sign. In April of 2008 Saturn at one degree of Virgo will trine Pluto at one degree of Capricorn bringing up issues that have been buried in subconsciousness and need to be acknowledged and addressed. This is a bit like cleaning out the cellar and will give us a preview of the new energy Pluto will fully embrace in November 2008 when the small but mighty, dwarf planet begins a long transit through the sign of Capricorn.

Next year, in November and December of 2008, Saturn in Virgo will oppose Uranus in Pisces and inconjunct Neptune in Aquarius (150-degree aspect). This is the last pass of Saturn opposed to Uranus, and combined with the influence of Neptune, asks us how our values have altered toward a more collective vision; are we still clinging to outworn forms or building a more enlightened future?

I believe among the lessons of this transit are learning to discriminate what is truly important and deserves an intense focus of attention and an expenditure of creative energy. We can learn to separate the wheat from the chaff, to use a Virgo example. Likewise, as we move into the Aquarian age, we need an understanding of the essential role our thoughts and predominant mindset have on ordering our world. Ultimately the question is: do we want more of the same or do we want to recreate the world according to a higher vision? ■

www.queenofcups.com

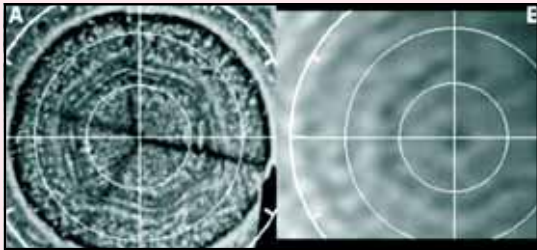

Saturn's Hexagon-shaped Cloud (NASA photo)

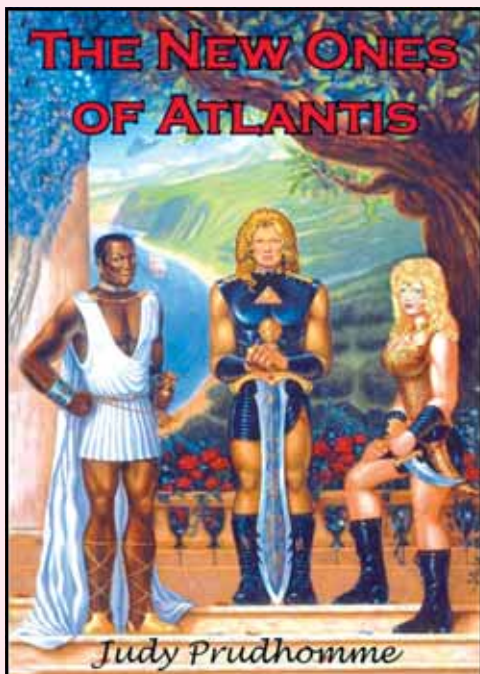

The New Ones of Atlantis

Author, Judy Prudhomme

Four 5-Star Book Reviews on Amazon

100 bookstores and 80,000 Booksellers Worldwide

Dream Seer, Judy Prudhomme, shares her lifelong visions of The New Ones and why Kleech, the alien Priest, created this superhuman species to rule and protect Atlantis.

The New Ones of Atlantis will ignite your imagination and whirl your emotions with a colorful adventure of extremes: shipwrecks and rescues; pirate debauchery and dedicated Priests; dangerous Warriors and happy children; whores and virginity; demons, ghosts, and the Holy Spirit; death, resurrection and reincarnation; Warrior Practice and Temple Day.

www.Amazon.com/books & www.BarnesandNoble.com

Buy Autographed Books From These Locations:

www.TheNewOnesofAtlantis.com

Necessary Luxuries at the Houston Galleria • 713-626-8252
5175 Westheimer Rd., Ste. 2130 • Galleria 3 • Houston, TX 77056

Your **FATE** Awaits You

**Don't miss a single issue.
Subscribe to FATE magazine today!**



- Ancient Mysteries
 - Crop Circles
 - Alien Abductions
 - UFOs
 - Atlantis
- Alternative Archaeology,
 - Lost Civilizations
 - And more ...

Each and every month, FATE covers it all like no else.

Published since 1948, FATE is the longest-running publication of its kind in the world, supplying its loyal readers with a broad array of true accounts of the strange and unknown for nearly 60 years.

FATE is a full-color, 130-page monthly magazine that delivers a one-of-a-kind reading experience.

6-month subscription only \$19.95

Call 1-800-728-2730 or visit www.fatemag.com

FATE *True Reports of the
Strange and Unknown*

PO Box 460 • LAKEVILLE, MN 55044

The Dimensions of Infinity

The Word 'Frontier' Is Entering an Entirely New Domain

• BY MARSHA OAKS

We stand at a very special point in time, between all that has preceded this moment and all moments to come and, moreover, we are also situated at a very precise point at the frontier between all that is small and all that is large—between the microcosm and the macrocosm. While it may seem, to some, that there is nothing special about that position, we are beginning to understand that any other place would be impossible. In this issue we feature two new DVDs which help to clarify the significance of our place in time and space, and the re-release of a set of three classic productions which help put our very ancient past into perspective.

CROSSING THE EVENT HORIZON: Rise to the Equation

Nassim Hamein

Do you remember what were you doing at nine years old? Were you thinking in depth about dimensions and geometry? I know I wasn't—but Nassim Hamein was! And he decided at that age that he was going to solve the problems that he encountered in school regarding dimensions. He wanted to solve it that same day, and being a child, he thought he could. On the bus ride home, he made an impressive attempt at the solution. But, of course, it brought up many more facets of the problem. And though he didn't know it at the time, he was actually tackling one of the fundamental difficulties in advanced physics—something so crucial for our understanding of reality that it bleeds into advanced physics, advanced mathematics and all sorts of sciences. (This is all thoroughly explained by him in this workshop symposium.)

That was the start of 20 years of seeking knowledge about the structure of space and time and the nature of reality, which has resulted in a unification theory with implications in theoretical physics, cosmology,

CROSSING THE EVENT HORIZON

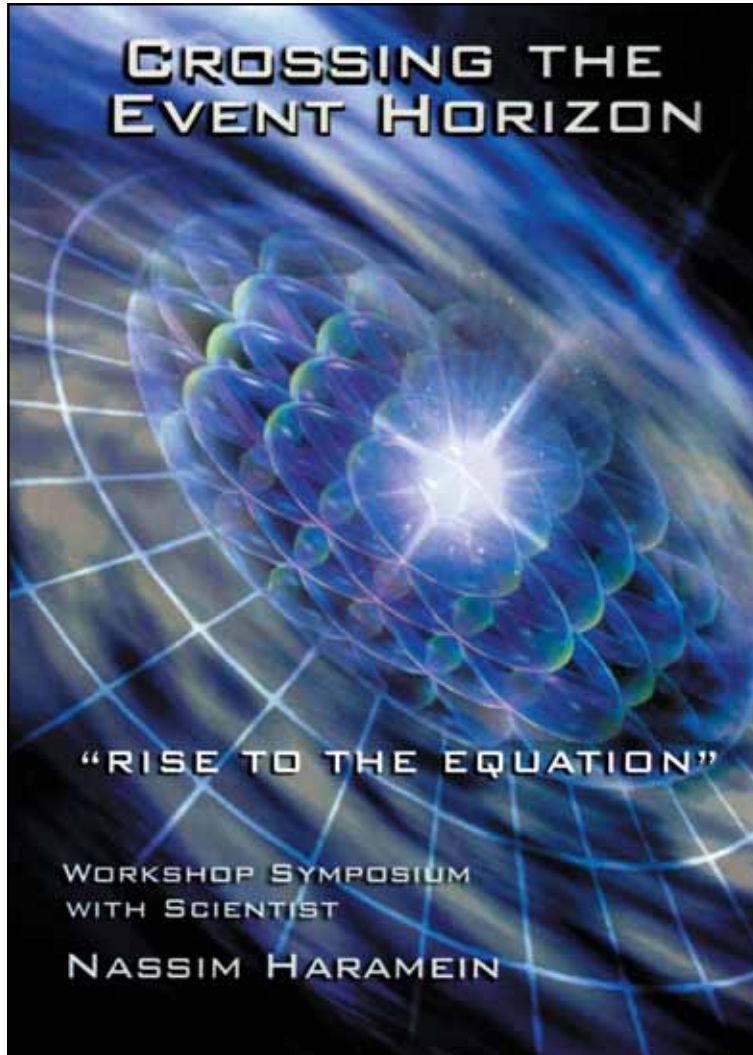

"RISE TO THE EQUATION"

WORKSHOP SYMPOSIUM
WITH SCIENTIST

NASSIM HAMEIN

quantum mechanics, biology, chemistry, archaeology, and anthropology, as well as philosophy and technology.

Born in Geneva, Switzerland, in 1962 to a Persian father and an Italian mother, he now lives in the United States. Always the independent thinker, he was kicked out of a science conference years ago for saying that we would find giant black holes at the centers of galaxies including our own. That prediction has come true, so now when he speaks of "black-white" holes, maybe we should listen! Speaking of a deeper view of black-hole dynamics, he says: "Black holes are no longer only absorbing material/information, but radiating this information back out in the form of electromagnetic radiation, and the feedback between the two generates the topology

of the dual torus structure of the Hamein-Rauscher solution driven by space-time. Now the black hole is no longer black since its exterior event horizon radiates, which is what I have been calling the white hole portion. Here the black hole/white hole are concentric to each other, where the black hole is inside and the white hole is concentrically structured outside and activates the plasma dynamics and Coriolis forces of the ergosphere of the black hole, which I coined the "black-white whole." (Hang in there—you'll get it!)

Even Dr. Stephen Hawking, who for nearly thirty years insisted that black holes could not radiate information, has recently announced a complete 180-degree turn in his views (much to his credit!) predicting that black holes may be able to radiate information.

Hamein has teamed up with renowned physicist, Elizabeth A. Rauscher, who has been awarded for outstanding contributions to astronomy and astrophysics, bioelectromagnetism and foundations of quantum theory. She was a nuclear scientist and researcher at Lawrence Berkeley National Laboratory and at Stanford Research Institute, Professor of Physics at

John F. Kennedy University of California, and research consultant to NASA and the U.S. Navy. She is author of over 200 scientific papers and four books, and she holds three U.S. patents and one European patent. Together, they have completed a scientific paper entitled, "The Origin of Spin: A Consideration of Torque and Coriolis Forces in Einstein's Field Equations and Grand Unification Theory." This paper has been accepted for publication by the peer-reviewed *Noetic Journal*, which publishes books of papers on the leading edge.

And this research IS on the leading edge! You see, according to Hamein, with all of the intricacies of both quantum theory and relativistic equations, no concepts nor fundamental theories have been postulated to de- ➤

scribe the origin of spin. Without spin/rotation, none of reality can come to exist. All things spin—even things that appear not to spin! Every atom in everything spins, on a planet that is spinning, in a solar system that is spinning inside a galactic disk and so on. One could say that spin is fundamental to creation. Their paper addresses this issue by adding a term to Einstein's equations which accounts for a fundamental force in space-time generating torque, which is forcing the space-time manifold to spin. He stated that they solved the equation and related the solution to a modified Grand Unification Theory for the electromagnetic and subatomic particle scale of reality, and in doing so they have bridged the macro and the micro.

They named this amendment to Einstein's Field Equations the Harahein-Rauscher solution. They believe that it will more accurately predict the observed dynamics of our universe, including its galactic clusters, galactic structures and universal behavior, without the need for exotic inclusions such as dark matter and dark energy. (When establishment physicists use Einstein's Field Equations, they conclude that they're missing 98% of the mass of the universe. Instead of revising their equations, they assume something out there that they can't see and they call it "dark matter" or "dark energy.")

So, where do we each fit into this picture? Harahein says that our own living cells are at the point where the micro and macro spin, and sees empowering implications in such data. "The body's complexity is outrageous!" he states.

"The biological resolution is the link between the large and the small—YOU are the event horizon. Instead of seeing yourself as an insignificant little dot that means nothing to the universe, begin to see yourself as the center...everyone else is the center of their universe as well...and we are all one."

The lay person, such as I, can follow enough of Harahein's step-by-step logic to completely enjoy this fascinating presentation. (He says that although this information seems quite complex, it is actually very accessible to everyone and that he teaches this material to seven-year-olds and eighty-year-olds and anywhere between, and everybody can get it.) I suggest that you DO plan the viewing times of this DVD, however, just as you are advised to do by the narrator at the very beginning. It would be best that you allow only short breaks between viewings, so you don't lose the continuity. And—you can't chitchat during it either, or you will miss some important connections. Sounds serious, doesn't it? But it's great fun, so just use the pause button when you wish to have a discussion, and then continue on, that's

all. Harahein's light-hearted, enthusiastic approach is infectious, and the visuals and graphics are superb! This will be money well spent on a DVD you will view over and over and over again!

4-DVD set - 6 hours
\$65.65
1-800-228-8381

QUANTUM MIND OF GOD

Philip Gardiner

There is a somewhat reverent tone to Gardiner's narration this time, as he discusses the ultimate question—does God exist? He gives his overview of the latest science and makes historical references as well. He points out that a series of special numbers now exists which explain how all things work from the atom to the largest sun, gravity, electromagnetism, light, and all manner of phenomena merged with the inter-linked, intertwined mathematical strands that unite all things together. What was created was a wonderful, crystal-like structure often termed the matrix. He quotes Max Planck: "We must assume behind this force the existence of a conscious and intelligent mind. This mind is the matrix of all matter."

Gardiner believes that we as humans are poised at the very center of this force and explains that it would take as many humans to

					
TOUCHED with Dr. John Mack DVD \$24.95	the Cosmic Connection 6 Shows: Jacobs, Hill, Dean, Strieber, More DVD \$15.95	Lost Realms Zecharia Sitchin DVD \$9.95	UFOs: The History and Evidence DVD \$14.95	California UFO WAVE David Sereda DVD \$21.95	Alien Technology Stacy Keach DVD \$14.95
					
The Fabric of Time Shroud of Turin DVD \$19.95	Fallen Angels - Unclassified UFO Crashes of the S.W. DVD \$19.95	A Space Story Friedman, Pope, Hutchinson, and Agnew. DVD \$19.95	The Brandon Corey Story with David Icke DVD \$19.95	Chariots of the Gods Classic Documentary DVD \$19.95	CircleSpeak Award Winning DVD \$24.95

Add \$4.95 for 1st DVD, add One dollar for each additional DVD

Available at www.theUFOstore.com

theUFOstore.com
1930 Ash Street
Baker City, OR 97814

Order by Phone
541-523-2630



make up the mass of the sun as there are atoms within each one of us. The sun is a billion meters in diameter, and a molecule is a billionth of a meter. We are perfectly situated in between. This is perfection in a mathematically balanced nature. And yet we are all unaware of our special position. Our size and our position in the solar system is crucial for life to exist as it does. Molecules, living cells, and minerals are all formed by atoms combining together in special mixtures to create different substances. All are atoms; all are particles; all have some nuclear particles, and the galaxies themselves are held in position by these sub-nuclear particles. What scientists do not yet know are the ultimate questions for them: What is the synthesis between the cosmos and the quantum world? What is the thread that links the quantum to the cosmos? Gardiner says that it is because of division in language, our perception, that this answer cannot be found, but we will discover the secret, wave-like thread and find that if we pull upon it, we shall unravel the mysteries of the universe.

Well, maybe that's exactly what Haremein is onto (see review above for "Crossing the Event Horizon"). At least, it appears to be. Also covered by Haremein is the subject of dark matter, which is a part of Gardiner's discussion.

It is Gardiner's assertion that if a correlation were drawn between ourselves and the greater universe, then the galaxies of light would be the conscious world; and dark matter would be the unconsciousness—that we are in a remarkable likeness to the universe to what some would call God.

Discussing the topic of crystals, he once again refers to dark matter, saying that the form of a crystal is configured just like that of the universe, and indeed our own mind, which is also mainly empty space (no reference to air-headed!). It is in this space that scientists store and harness vast amounts of information, in the dark matter of the crystal.

Gardiner further talks of the void inside every atom as well as in the vastness of space and says that we call it dark matter because we don't understand it.

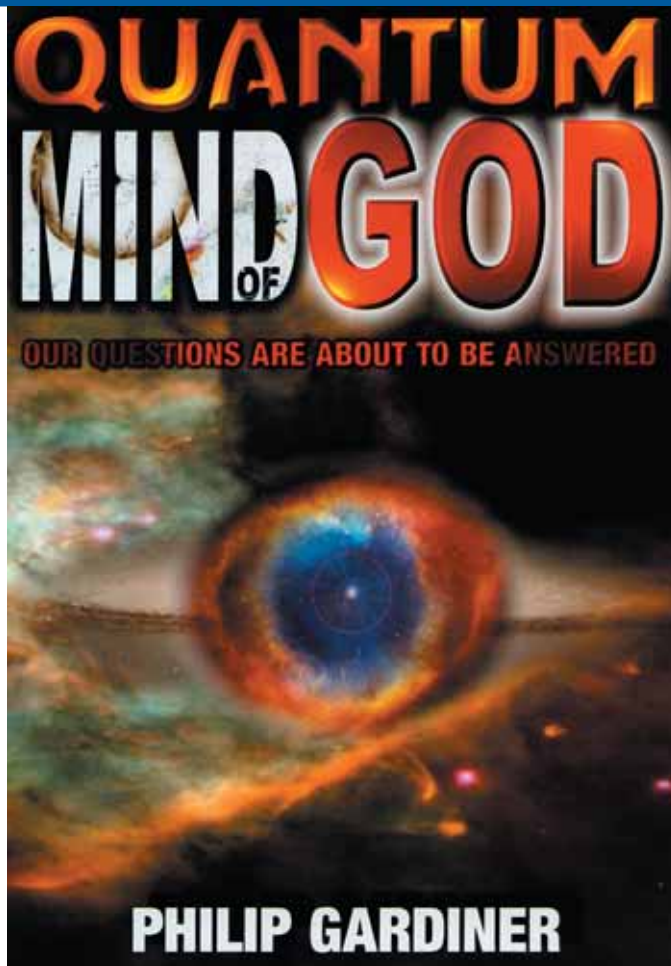

But maybe Haremein's solution can shed light on this for him, as stated above.

I suggest that you view both Gardiner's and Haremein's DVDs, as the topics are interrelated.

This production has nice graphics, which we have come to expect from Reality Entertainment's productions. And yes, the music is appropriate most of the time; it rarely overrides Gardiner's narration.

DVD - 65 min.

\$24.95

1-800-228-8381

**MYSTERIOUS ORIGINS OF MAN:
Rewriting Human History
B.C. Video**

For those who follow the topics of this magazine there have been several major media events which have helped to open public awareness to the issues which we address. At the top of the list has been NBC's broadcast of *The Mystery of the Sphinx* in the mid '90s. The program, narrated by Charlton Heston introduced the public to the notion that there was a view contrary to standard egyptology about the age of the Sphinx, and thus the age of civilization, and that this view was supported by the strongest kind of scientific evidence—namely geology. The program caused a sensation, enjoyed very high ratings, won an

Continued on Page 55

England and the Atlantis Connection

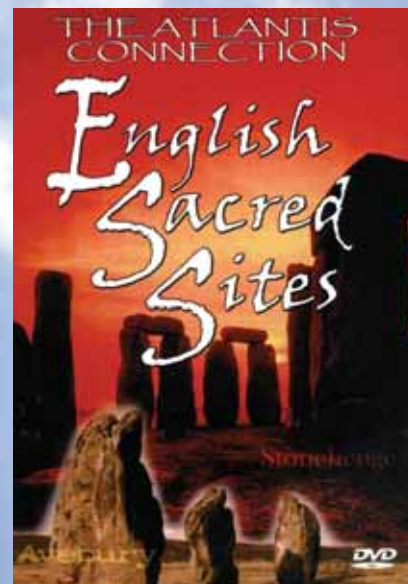

Atlantis Rising Video presents *English Sacred Sites: The Atlantis Connection*.

The new 40-minute VHS program pulls together powerful evidence linking Stonehenge, Avebury, Glastonbury and many other English locations with an advanced ancient order now lost to history. Written and narrated by *Atlantis Rising* editor Doug Kenyon, the video is based primarily upon the discoveries of Cambridge-trained scholar and author John Michell. The program demonstrates how a mysterious network of perfectly straight tracks, laid out for hundreds of miles across the English landscape, proves the great advancement of pre-historic science. Michell's deep insight into the origins of English culture illuminates a startling new vision of the roots of civilization.

Beautiful on-location footage interspersed with spectacular 3-D animation and a great original music score make *English Sacred Sites* not only moving and persuasive but entertaining as well.

1 Hr. DVD \$24.95

or VHS \$19.95

+ \$5.95 S.&H.

To Order Call

800-228-8381

New invention allows human to stay physically young FOREVER!!!!

Highly recommended by
Kevin Trudeau
 (Author of Natural Cures)



Wear these magnetic rings everyday during sleep and it will reduce your age. You will start looking younger everyday. Highly recommended by Kevin Trudeau's Natural Cures book (page 194 & 166) Too many testimonials on our website. Just \$45 a pair shipping included.

Wear these magnetic foot braces in order to increase the strength of the rings. Over 1 million sold in the USA.



Immortality Foot Braces



Send payment to:
Dr. Julian Michelucci
 236 Broad St.
 Suite AT
 San Francisco, CA 94112



Over 1 million sold in the USA alone!
 As seen on TV!

MagneticDiscovery.Net

Gorgeouspil An all natural herbal supplement that makes a person prettier each time the pill was taken. It literally alters the shape of your bone to make you prettier. Very advanced technology.

Tel: (650) 2192508

We also have other strange and highly advanced



Picture of Franco Fiori of Italy. After a few weeks, more romantic eyes, smaller nose, more symmetrical face. From an average man to a TV star in just a few weeks!

technologies on our website. Hundreds of testimonials are available.

MagneticDiscovery
.Net

Continued from Page 53

emmy and did much to create the climate in which this magazine emerged. *The Mystery of the Sphinx*, though, was not the end of the story. Soon the producers were back on the air with another, even more controversial, program. Also narrated by Charlton Heston, *The Mysterious Origins of Man* challenged the very foundations of conventional archaeology and paleontology, focusing primarily on the research of *Atlantis Rising* columnist Michael Cremo and Richard Thompson in their underground classic *Forbidden Archaeology*. At the core of the show's argument was the notion that modern humans have been around much longer than is generally believed by orthodoxy. Once again, the show stirred up a hornet's nest, which may be the reason that NBC, despite the continued good ratings, apparently tired of the battle. There would be no more prime time specials. The producers, nevertheless, soldiered on and brought forth a followup, *Mysterious Origins of Man II*, and subsequently another program on a similar theme, *Jurassic Art*, dealing with a strange collection of artifacts known as the Ice stones.

The two *Origins* shows and the *Jurassic* show were first sold as a set in VHS several years ago, and now have been re-released in a new package from UFO Video as a 3-DVD set. If somehow you missed the original productions, you owe it to yourself to get the new set and to see for yourself what all the ruckus was about. The three-part director's cut of the NBC Special has been remastered and includes over four hours of bonus documentary material.

With *Origins I and II*, B.C. director Bill Cote has created a revolutionary pair of films that examine one of our greatest mysteries—human origins. All three shows challenge what we are being taught about human evolution and the rise of early civilization. A new breed of scientific investigator presents startling evidence that the academic community has ignored:

Did humans evolve from the ape? Human artifacts and bones have been found that are older than the theory of evolution allows.

Did humans live at the time of the dinosaur? Human footprints have been found next to dinosaur footprints dated to over 100

million years ago.

Could the "Lost Continent of Atlantis" be buried under two miles of ice? Graham Hancock reveals how ancient maps may hold the answer to the mystery of Atlantis. A megalithic city high in the Bolivian Andes has been dated to 15,000 B.C. What unknown civilization could have built it?

If this compelling evidence is allowed to

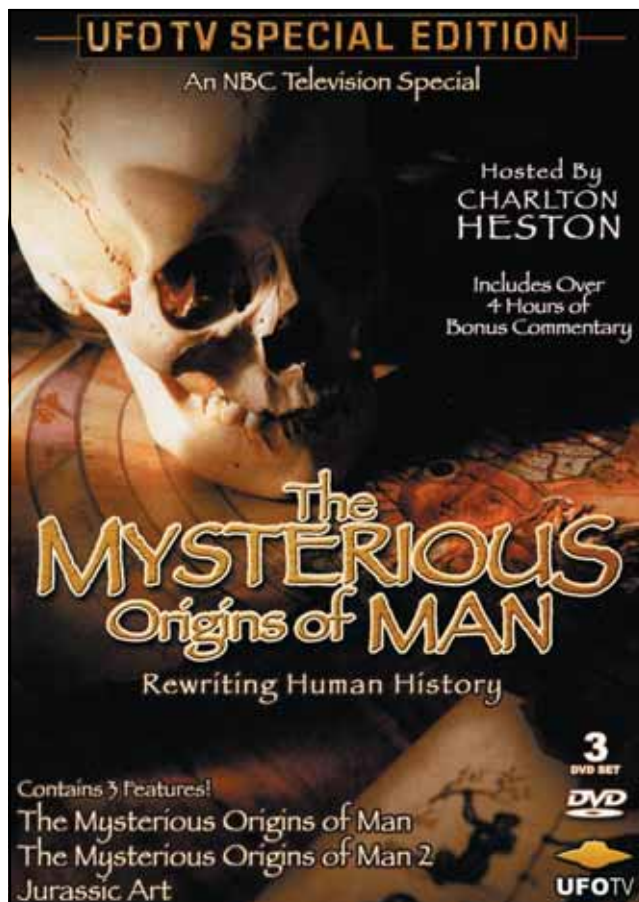

speak for itself, human history on this planet could be radically different than what is accepted today and may be due for a full rewrite. Included here are the facts about this amazing mystery and a fascinating series of spellbinding interviews with researchers, scientists, and the best known, most credible authorities in the world today. Included are uncut interviews with Robert Bauval, David Childress, Michael Cremo, Graham Hancock, Richard Milton and Richard Thompson.

Next time you are in an argument with some hard-headed defender of conventional group think, these are the programs you will want to introduce in defense of your side, and then rest your case.

Needless to say, the production quality, as you would expect from a major network production, is first class, featuring great on-location footage from all over the world, terrific editing, and wonderful music.

3 DVDs - 341 min.

\$49.95

1-800-228-8381 ■

**FREE SAMPLE
& Discount Offer**

E3LIVE™

NATURE'S PERFECT FOOD!

Liquid Aphanizomenon Flos-Aquae (AFA)

- Stops Junk-Food Cravings, Normalizes Weight
- Has ALL the Vitamins, Minerals & Proteins
- Supercharges the Immune System
- Improves Emotional Stability & Elevates Mood
- Brain Power! Better Memory & Concentration
- Rich in Enzymes! Increases Intestinal Flora
- Repairs Cell Damage & Eliminates Toxins
- Promotes a Sound & Restful Sleep



**"E3LIVE" is
an Awesome
Green
Superfood!"**

**BLUE-GREEN
ALGAE—
Harvested
Fresh and
Delivered
Frozen**

from Lake Klamath, Oregon

Call 406-333-9800
for a **FREE SAMPLE**,
(capsule form) with
CD & BOOKLET
You'll be convinced!



**Order Fresh-Frozen E3LIVE™
at 888-800-7070**

Mention **Atlantis Rising**
& Get **20% OFF** Your 1st Order!

www.e3live.com • sales@e3live.com
(discount not available for online orders)

COLLECT THESE GREAT BACK ISSUES!

- 3 Peter Tompkins • Ancient ETs • Dead Sea Scrolls & New Age Jesus • Magical Journeys\$45
- 4 Graham Hancock • Dannon Brinkley • Hall of Records • Impossible Inventions\$38
- 5 Zecharia Sitchin • Robert Bauval • Out of Place Artifacts • Secret History\$35
- 6 Michael Cremo • Gordon Michael Scallion • Evolution vs. Creation • Cosmic Collisions\$33
- 8 Edgar Mitchell • Where Was Atlantis • The Sphinx Scandal • Age of the Pyramid\$28
- 9 Colin Wilson • Beneath the Martian Rock • Moira Timmes • Goddess Runes\$25
- 10 Psychic Spooks • Crystal Skulls • Ancient Aircraft • UFO Coverup • Paul Roberts\$23
- 11 Chinese Pyramids • Jurassic Art • Pattern from the Other Side • Carbon 14 Problems\$23
- 12 John Michell • Cataclysm 9500 BC • Edgar Cayce on Atlantis • Coral Castle Mystery\$22
- 13 Japan's Undersea Ruins • Secret Tunneling in Great Pyramid • Tesla/Marconi Connection\$20
- 14 Crop Circles • Darwin Problems • Rand Flem-Ath on Atlantis • Ostrander & Schroeder\$19
- 15 Giza Hall of Records • Zecharia Sitchin • Psychics and Science • Christiane Northrup • Victor Hugo\$18
- 16 Politics of New Energy • Giza Power Plant • Art Bell • Future Memory • Back Engineering Roswell\$16
- 17 Nostradamus Code • Clairvoyants on the Case • Atlantis in America • Alan Alford • Moira Timms\$16
- 18 The Electric Universe • Linda Moulton Howe • Caribbean Stargate • Premonitions of Disaster\$16
- 19 John Anthony West • The Power of Water • Cold Fusion Proven • Isaac Newton and the Occult\$14
- 20 Robert Bauval on Alexandria • Jean Houston • New Energy Secrecy • American Templar Treasure?\$14
- 21 Christopher Dunn • Shakespeare Riddle • Revisionists of Third Kind • Redfield on Shambhala\$14
- 22 Quick Frozen Mammoths • Politics of Anti-Gravity • Shape Power Richard Noone • Mahabharata\$14
- 23 Ralph Ellis on Bent Pyramid • Robert Schoch • Dead Mars, Dying Earth? • Biological Apocalypse?\$12
- 24 The Pulsar Mystery, Paul LaViolette • Petrie Museum • Hydrogen Revolution • Houdini's Last Escape\$12
- 25 Ma'mun's Tunnel Mystery • Holton Arp • Remote Viewers in Alexandria • Secret of Rock Lake\$12
- 26 Zecharia Sitchin • Poured Pyramids • Father Ernetti's Time Machine • Ancient Armageddon\$12
- 30 Edgar Cayce's Caribbean Reconsidered • Velikovsky's Martyrdom • Omm Sety • Teleportation\$10
- 33 Gene Savoy • Gulf of Cambay • Altered States • Approaching Zero Point • Michael J. Gelb\$10
- 35 Martian Iceberg • Russian Energy • Mt. Sinai • Pyramids of Scotland • Col. Fawcett's Quest\$10
- 36 Wonder Kids • Tobacco & Radiation • Cathars • Serpent Mound Mysteries • UFO Disclosure\$10
- 37 Pyramid Doors • Jose Arguelles • Asteroids as Nukes • Crop Circles • Cuban Atlantis • Crystal Skull\$10
- 38 Microchip Implants • Rosslyn Chapel • John Major Jenkins • Rupert Shelldrake • Ancient Sounds\$10
- 40 America's Ancient Architect • Ancient Hi Tech • John Anthony West • Laurence Gardner\$10
- 41 The Case for the Flood • DeSoto & the Hall of Records • Maclain's Lemuria • Darwin's Demise\$10
- 43 Atlantis off Cyprus • Pentagon's Coat of Many Colors • Hypnosis & Hitler • Alien Abductions\$10
- 44 Sunspot Connections • Psychokinesis vs. Gravity • Manley P. Hall • Isaac Newton & the Bible\$9
- 46 Christ Mystery • America's Chernobyl • Asia's Pyramids • Baird T. Spalding Story • Sitchin on Mars\$9
- 47 Noah's Ark • Knights Templar in America • Nanobacteria • Where Was the Real Troy?\$9
- 48 Ancient Time Travel • Light on Tunguska • Rosslyn Chapel • D. Chopra • Crook & Flail Mystery\$9
- 49 Communicating with Other Side • Montauk to Mars • UFOs at North Berwick • Mayan Prophecies\$9
- 50 Nat. Secrets • Singing Pyramid • FDR & Hi-Tech • Quantum Menace • Ancient Egypt & the Brain\$9
- 51 Atlantis in the Bahamas • Indian Antigravity • General Pike & the Klan • Ancient Forcefields\$9
- 52 Robert Schoch: Great Pyramid • Reincarnation Proof • Biology of Transcendence • Christian Origins\$9
- 53 Lost Sailor's Map • X-Ray Vision • Precession Paradox • Ogygia Atlantis? • In Search of "The Field"\$9
- 54 Francis Bacon as Shakespeare • Extraterrestrials & the Vatican • Templars at Domme\$9
- 55 Weather Wars • Markawasi • Ancient Metallurgy • Underwater Bases • San Francisco's Pyramid Saga\$9
- 56 Astronomers of Nabta Playa • Templar Secrets & the Vatican • Electromagnetism & the Ancients\$9
- 57 Project Stardust • Skeptical Hoax • Beyond the Last Caravaggio • The Murder of John Cabot\$9
- 58 India's Mystic Military • True Da Vinci Code Secrets • The Roswell Glyphs • Atlantis & the Great Pyramid\$9
- 59 Did Jesus Visit India? • Invisibility Tech • Nazis & the Occult • Precessional Puzzles • A. C. Doyle & the Grail\$9
- 60 The Number of Lost • Atlantis & the Neanderthals • Dragons of the Ishtar Gate • Hitler's Nuke Threat\$9
- 61 Graham Hancock • Project Serpo • Gnosis • Holy Grail in America • Ancient High Tech\$9
- 62 American Heretics • What Happened to the Maya • Quest for the Holy Grail • Fire from Water\$9
- 63 Rosslyn Chapel • Antimatter Weapons • Little People • Deepak Chopra • Shakespeare\$9
- 64 The Cygnus Connection • Mussolini's Roswell • Power from the Nightside • Wright vs. Gurdjieff\$9
- 65 Mexico's Amazing Pyramids • Seeing the Future • Science vs. Levitation • The Nazi/ET Connection\$9



Send check, money order to Atlantis Rising
P.O. Box 441 • Livingston, MT 59047
Credit card orders, call 800-228-8381
 Prices include S & H, based on availability at press time
 Subject to change without notice

• BY CARLY SVAMVOUR

'AS THE WORLD TURNS'

ACROSS

- 1 & 5) Machine that converts other forms of energy into mechanical energy—Manning—AR #4
- 8) What must be started for a wienie roast
- 13) A male monarch or emperor
- 14) The day of allied victory in Europe
- 15) At another time
- 17) Columns of light
- 18) Fruiting spike of a cereal plant
- 21) The cardinal number that is the product of ten and five
- 23) A state in New England—abbr.
- 24) Radio concern formed in 1919 - abbr.
- 25) Designed to be played at 33.3 rpm
- 27) Have eaten—slang
- 29) A discharge of lightning
- 31) Compass point
- 32) US Intelligence agency—abbr.
- 33 & 35) A terrific catch—2 wds.
- 37) Where to find the Runic Riddles—Eigles—AR #14
- 38) His was the famous gravity theory, deduced by dropping an apple—Lewis—AR #1
- 39) Atomic number 85
- 40) Not out
- 41) Morning
- 44) The pioneer of modern day photo biology—Lofton—AR #11
- 46) Elvis Presley's middle name
- 49) Formed or united into a whole—abbr.
- 50 & 51) Director of the Wilhelm Reich Infant Trust—Manning—AR #63
- 52) Not in
- 53) Genus of trees or shrubs having winged fruit
- 54) The bivalent group -N=N- united to two hydrocarbon groups
- 55) Thyroxines
- 57) Stream(s) in the ocean—abbr.
- 58) Proceed
- 59) A dwarfed ornamental tree or shrub
- 62) A beach in North East Florida
- 67) Kind of war that could cause our civilization to become extinct
- 68) Expresses mild protest, sympathy, etc.
- 69) Morning—abbr.
- 71) A noise caused by a forceful impact
- 72) A state in southern United States on the Gulf of Mexico—abbr.
- 73) Atomic number 32
- 74) A member of the Siouan people
- 75) Indicates an affirmative response
- 76) Expresses position
- 77) A large vase with a pedestal or feet
- 78) Stanley Pons and Martin Fleischmann claimed they'd fused these at room temperature—Lewis—AR #2
- 79) 4840 square yards
- 81) Roman numeral
- 82) One thousand grams
- 85) Releases electrical force
- 86) What 1 & 5 across actually is—Manning—AR #4

DOWN

- 1) The worst kind of place for an asteroid or comet to strike—Jochmans—AR #6
- 2) He demonstrated that water weathering makes the Sphinx at least seven thousands of years old—Early Rays—AR #12—init.
- 3) Home state of Richard Noone—JDK—AR #14—abbr.
- 4) Circles an object(s)—Kettler—AR #13
- 6) This required NBC to put in an automatic answering machine after the airing of *Ancient Prophecies*—Miller—AR #1
- 7) An electrical device used to introduce reactance into a circuit
- 9) Kind of water that's used to generate electricity
- 10) Look over carefully
- 11) An artificial language based on abstract analysis of ideas
- 12) A fervent missionary of Soviet PSI research—Kasten—AR #14—init.
- 19) Ancient Egyptian sun god
- 20 & 42) What Anaxa-gorea is—2 wds.
- 23) Systematic investigation to establish facts
- 26) Events where things melt, break or become unusable
- 28) When alchemy comes in, there is a possibility of this being reversed—Manning—AR #9
- 29) Photographers often try to photograph lightning as it hits this big object in England

1	2	3	4		5		6	7		8		9	10	11	12
13							14					15	16		
			17				18	19		20		21			
22		23					24					25			26
			27		28		29	30				31			
			32		33	34		35		36					
					37					38					
		39			40					41	42				
43					44		45			46		47	48		
49				50			51						52		
					53					54					
					55			56		57			58		
59	60	61					62	63		64	65				66
							67						68		
			69	70				71						72	
								74						75	
										78					
79	80							81					82	83	84
85								86							

- 30) A unit of electrical resistance
- 34) Middles— Brit. spelling
- 36) First president of Zambia—init.
- 41) Home state of the Hohokam Indians—Childress—AR #3
- 43) Incapable of functioning
- 45) God of war and strife and son of Odin (Norse Myth)
- 46) Title for a civil or military leader (Turkey)
- 47) The cardinal compass point that is 0 or 360 degrees
- 48) A broad highway designed for high-speed traffic
- 50) Inst. of Technology where they tried and claimed to have failed to reproduce Pons and Fleischmann's cold fusion results—Lewis—AR #2—abbr.
- 56) Relating to atmosphere around a low pressure center
- 61) Place where you find 9 down
- 62) Not up—abbr.
- 63) Home of Olaf Alexandersson's Viktor Schauberger—Ray—AR #8
- 64) Three letter acronym
- 65) A company that sells things made from parts bought in bulk from another manufacturer—abbr.
- 66) Device that makes different pieces of apparatus compatible
- 68) State where you'd find indoor fusion-heated farming complexes
- 70) Measure
- 74) Informal term for S. African man
- 79) An electric current
- 80) He who held the crustal displacement theory—Kasten—AR #9—init.
- 83) Thing named or in question
- 84) _ _ and behold!

CRYPTOGRAM

KC NCZ HUXBRPU RE RY TUHUF'Y ECH UKRDCF TU'K AU TXY-GORFL YI AN GXFKBUBRLOY? ~XB ACBRDWX

Answer to CRYPTOGRAM from #65
 "The earth is the very quintessence of the human condition."
 Hannah Arendt
 The Human Condition, 1958

'WILD THINGS—YOUNG AND OLD' #65

C	E	B	A	B	A	B	O	O	N	M	A	M	M	A	L	S
A	E	A					P	J	U	R	A	S	S	I	C	
R	E	L	O	C	A	T	E	S		W	A	D	E	S		A
B	M		T	S	A	R				W		T	U	L		
O	U		M	E	N			P	S	P	O	O	R	S		E
N			A	R	A	C	K	T		R	D	U				
I			E	M	I	G	R	A	T	E	B	E	O	R	P	
F			M	A			E	R	O	N	N	D	P	R		
E	C	H	O		S	T	E	G	O	S	A	U	R	E	O	
R	A	T		A			D		P		V	A	G			
O			H		A	C	T				A	L	I	T		O
U	A	S		S	E	A		C		I	A	N		O		
S	L	T		O		O		T	R	I	A	S	S	I	C	S
			E	A		U		Y		A	L	I	S	A		T
B			P	A	L	E	S	T		L		D	E	N	A	I
E			H		W					P	A	L	S		R	C
A						A	D	M	I	T	B	E	R	E	S	O
S						I	B	E	R	I	A	N		E	E	T
T						I	B	E	T	A	N		F	E	M	U

Continued from Page 16

Ring had observed that rivers meander across a landscape, so perhaps an electron also naturally spirals along its way. So instead of hitting the electron with brute force electricity, he gently pulsed it. It worked the first time. He repeated the experiment until satisfied, wrote up his notes, then tackled levitation. He avoided the expensive superconductivity approach that produces a few minutes of levitation in the laboratory before coils burn out. Instead, he knew acoustic levitation of rocks had worked for monks in Tibet; why not here with woofer speakers? Before the night was over he did get a ping pong ball to hover on demand.

Naively expecting a raise in salary, Ring took his report and photographs to the laboratory's director the next day. The director motioned for him to close the office door and said he believed that, yes, Ring had made two of the laboratory's tasks obsolete. He hadn't expected Ring would do so. However, Ring couldn't tell anyone about it. The director told him to just go back to work the way he had been doing. Why? "You don't understand. This is a government-funded lab and we're paid to look for answers but not to find them."

Ring is not a man who can work in such a system. Although his wife would be angry, he resigned within two weeks, tears in his eyes. That act of courage opened the door for a new chapter in his life. But first, he learned about vested interests.

Mysterious visitors showed up at the Ring home—before he had heard about rumored 'Men In Black' who are said to threaten some innovators. Ring answered their questions about his inventions, but his wife had a sixth sense for trouble. She was increasingly uneasy while the visitors became more pushy in asking how Ring knew so much. Finally she told them to leave. Afterward, she ordered her husband to remove experimental equipment and papers from the house—including the rare leather-bound Tesla book he had ordered from Yugoslavia.

Ring was reluctant to throw out such a valuable book. Following inner guidance, he took it to the Mohave desert and gave it to a well-known man he had not previously met, George Van Tassel (www.Integratron.com), who said "I've been expecting you."

For a while Ring's life became a symphony of synchronicities. A friend took him to the discussion group *Understanding*, formed by Daniel Fry. Ring confided his life-long dream for humankind—floating homes and floating cities. These people knew a kindred soul, in trouble in Oklahoma—Otis Carr—and decided to bring Carr to California.

Carr, whom Ring describes as a humble man, and Ring bonded through their love for nature and magnetism. Ring learned about Carr's capacitor-like "Utron Electrical Accumulator." Carr's invention as Ring recalls in-

cluded a double tetrahedron which he said has a tremendous amount of power when exposed to a magnetic field.

One member had a cabin where Ring and Carr's team stayed while another Understanding member located a laboratory with warehouse and machine shop. The team built models and flew their experimental craft around Apple Valley. Local people began to talk about flying saucers.

Since the laboratory's activities wouldn't remain hidden, Carr told Wayne Aho to contact General Motors. When a G.M. representative met them at a Riverside, California hotel, Ring recalls, Carr told him, "We want to work with you; you have an enormous manufacturing facility and we're working on a shoestring."

On a desktop the Carr team demonstrated a small hovering craft—a circular shape spinning horizontally. Carr informed the General Motors man they could replace car wheels which turn vertically on the ground and require asphalt roads which harm animals, spoil the landscape and waste money.

According to Ring, the automotive representative said, "Wait a moment. You're going to put all our people out of work? Magnetic energy—what's that?" Carr replied that we live in a sea of magnetic energy. The conversation ended when Carr's group was warned to forget about working with free-energy spacecraft. "If you guys put them up, we'll shoot them down."

A polite man, Carr thanked him for the meeting. He returned to their lab to announce that they must quickly get their new three-man craft into the air. If enough communities know about it, he reasoned, people won't let their efforts get shut down. They worked day and night for two weeks.

One part of the story reminds me of inventor John Hutchison's experiments. Carr's craft had counter-rotating rings on the outside and an unmoving pressurized cabin in the center. One day Ring touched the spinning periphery of a tethered three-foot model. When its vibrations per second reached a certain frequency, the aluminum felt soft. Then his fingers went through the edge—without injury. Metal had become transparent when vibrating in resonance with its surroundings.

The most incredible part of Ring's story is his account of a flight in the 45-foot model. Carr had been grooming his engineers, and technician Ring, to understand consciousness—to operate from the inside out. If they could relax and follow the instructions, Carr said, they would control the craft with their minds!

Inside the craft was a crystal globe about 18 inches in diameter sitting in a type of gyroscope, Ring recalls. A focused light pulsed up through the globe and lit the crystal in myriad colors around the spectrum. Since the craft operated with the principle of resonance, Carr's other helpers had somehow



Ralph Ring

measured the local energy field at a chosen destination about ten miles away, and that area corresponded with the frequency of the color aquamarine. At test time, the three-man crew watched the glowing crystal change to a brilliant aquamarine which lit up the interior of the craft.

When the experiment was over, Ring and the two engineers felt like they had only

been sitting in the craft for minutes or seconds. They believed they had not gone anywhere. Carr had expected their reaction. He said, "Look in your pockets." To the crew's surprise, they emptied small stones, sand and sticks out of their clothing. Carr had instructed them to get out and interact with the destination landscape, which they apparently had done, but the shock of the experience overwhelmed the ability of their physical brains to believe it was happening. Similar to people after a traumatic accident, the memory was wiped out.

Carr laughed and reminded them of his instruction to use their limitless minds instead of the brain. Like a computer, the brain will deny anything outside its programmed scope of operation. It will go to sleep when it reaches its optimum level of comprehension. Apparently their brains weren't ready for teleportation. However, the crew had learned from Carr to get beyond fear and use intuition, otherwise the exotic craft would not have worked for them. He had taught that instead of being a human being with a spirit in it, each is spirit, living in a physical being. Carr had insisted that his pilots resonate with the idea that we are energy, not bodies, and energy cannot be destroyed.

Ring told the audience that a camera had filmed the craft's brief disappearance, and an associate is looking for that eight-millimeter film. "The truth is on film."

Carr's intuition told him they were going to be shut down; maybe the next generation would be ready to look into a higher and deeper way of operating a society instead of using up scarce resources. Ring recalls Carr's message to his crew as, "Sooner or later they're going to paint themselves into a corner, and then they're going to start listening to people like you guys. You know where you've been and what you've done."

Before they could carry out their plan to fly over Los Angeles to get public exposure while resonating a craft at visible frequencies, the next week military vehicles containing soldiers drove into their fenced work area. Officials presented a document and said the Carr group was no longer allowed to work together. Why? "You're attempting to overthrow the monetary system of the United States and that can be treason."

All their equipment and papers were confiscated while the crew was interrogated for what seemed like hours. "They threatened us with all kinds of unhealthy things." The crew was forced to disperse to separate parts of the country and cease contact with each other. Carr went back to Baltimore.

Continued from Page 22

Officer, Major Jesse Marcel "would fly the debris to Fort Worth;" 2) Col. Blanchard ordered him to write a press release and deliver it first to local radio and newspapers; 3) he reports reading in the newspaper the following day General Roger Ramey's weather balloon explanation; 4) he believes not only that Col. Blanchard saw the original debris, would never have confused the actual crash debris with a weather balloon, and neither would have Jesse Marcel; Haut confirms Jesse Marcel personally told him that what he recovered wasn't what was shown to the press; 5) Haut is convinced "the material recovered is from some craft from outer space."

His first affidavit, while ostensibly confirming many elements of the now well-known Roswell standard story, is hardly inflammatory or world-stopping. What did he swear really happened, though, when he knew he wouldn't be around to deal with the aftermath of his truth telling?



The late Walter Haut

The 2002 Affidavit

In the new affidavit, things start out innocuously enough, then head rapidly into high strangeness. Instead of five principal points, we now have fifteen (the link given earlier has all the details, together with full sourcing for the two affidavits):

1) Haut restates his official job at Roswell, but adds that he spent the 4th of July weekend at home.

2) By mid morning, July 7, he already knew of a downed vehicle report and that Major Jesse Marcel was detailed by Col. Blanchard to investigate.

3) By late that afternoon, he had civilian reports of a second site just north of Roswell (Brazel's ranch was 75 miles NW of the base; the second site was 40 miles N).

4) Tuesday, July 7, 1947 saw a most unusual "usual" staff meeting held, with the long hard-to-identify Capt. Sheridan Cavitt of the Counterintelligence Corps (CIC), Col. James

I. Hopkins, the Operations Officer (Robert Shirkey, Senior's boss), and the Base Supply Officer, Lt. Col. Ulysses S. Nero, to which were added Blanchard's boss, Brigadier General Roger Ramey, his Chief of Staff, Col. Thomas J. Dubose, both from Carswell Army Air Field in Fort Worth, Texas (where Marcel and other sources say the >

Later, Ring was told by a professor that the 45-foot craft was in Los Alamos, New Mexico, nine stories down. His friend reported that government officials tried to operate it, but were unsuccessful because they don't understand how the key to powering it lies in consciousness. They wanted to mount weapons on it. However, weapons simply don't operate in the high-vibrational field of such advanced esoteric technology, Ralph Ring told me during a phone interview.

There's no way I can verify details of this story. However, during his decades of seclusion Ring at one time worked on a project with a friend of mine in New Mexico, who affirmed that Ring's story has essentially been the same all these years although he may not remember all the technical details. Ring wanted to build a replica of the 45-foot craft but ended up with an intuitively designed underground home, because local building codes don't allow unanchored houses with built-in sewage treatment plants. Photos of the home are on the DVD of his presentation (www.TeslaTech.info).

His secluded life changed in 2006 after Bill Ryan and Kerry Cassidy of Project Camelot contacted him and said times are different now; people will listen without so much scoffing. Their interviews started a chain reaction of invitations for Ralph Ring to speak, and to bring to light more indications that humankind could cooperate with nature, clean up earth and soar into the skies. ■

THE INTERNATIONAL UFO CONGRESS **17th Annual International UFO Congress Convention & Film Festival**

February 23, 2008 - March 1, 2008

Weekend Package \$199.99
8 Day Full Event Package \$619.99
 All packages include Double Occupancy Accommodations

For more information visit **www.ufocongress.com**
 (303) 651-7136 - 6160 Firestone Blvd. #104-373, Firestone CO 80504

30 World-Class Speakers
 35 Exhibitors
 Meet the Speakers Party
 International Film Festival
 EBE Awards Banquet
 Experiencers Sessions
 Keynote Speaker Dinner

crash debris was flown). The main topic was the debrief of Marcel and Cavitt on the Brazel ranch site, with a preliminary report by Col. Blanchard on the second site. What's said is so strange it bears quoting. "Samples of wreckage were passed around the table. It was unlike any material I had or have ever seen in my life. Pieces which resembled metal foil, paper thin yet extremely strong, and pieces with unusual markings along their length were handled from man to man, each voicing their opinion. No one was able to identify the crash debris." All of a sudden, the number of people who handled the crash debris and are identifiable by name goes up from a handful to a roomful. They're describing the same items Jesse Marcel, his son, Jesse Marcel, Jr., and several others have previously reported handling.

- 5) Here we find ourselves face-to-face with a veritable smoking gun, in the form of discussion regarding the use of a Cover & Deception plan to hide "the more important site north of town by acknowledging the other location" as part of the larger issue of whether to "go public or not with the discovery."
- 6) Haut reports that after the meeting (9:30 a.m.) was when Col. Blanchard called him and dictated the soon-to-be-famous and later notorious press release. Distribution was as above.
- 7) Haut says the press release generated such enormous reaction (calls from around the world) that Col. Blanchard suggested he go home and "hide out."
- 8) Here, Haut drops a bombshell, stating that Col. Blanchard took him to Building 84 (known to ufologists as Hangar 84, but actually Hangar P-3, where he was shown the "object just recovered north of town. "It was approx. 12 to 15 feet in



The Infamous Weather Balloon wreckage

TBLN

.COM THE ALL PARANORMAL NETWORK

Watch STREAMING Shows online

JUST \$1.99

or less!
Streaming
Single show

EVIDENCE: The case for NASA UFOs

FASTWALKERS
The North Pole Inner Earth Expedition
Presented by Dr. Brooks A. Agnew

Interstellar

ENCOUNTERS with ANGELS, UFO's

the Brandon Corey Story
with David Icke

Fallen Angels
UFO Crash Retrievals
in the Desert SW

Forbidden Knowledge
Conference UK 2006

TOUCHED
with Dr. John Mack

Monsters of the UFO
The Incident at Kelly

From Here to Andromeda

Barry Taylor's
UFO Down-Under

NICK POPE
The man who left the MOD

www.TBLN.com

The All Paranormal Broadband Network

length, not quite as wide, about 6 feet high, and more of an egg shape. Lighting was poor, but its surface did appear metallic. No windows, portholes, wings, tail section or landing gear were visible.” One can see why the government was willing to admit what was already widely known by civilians, in order to protect this stunner. Haut confirms the multiple reports by eyewitnesses of heavy inner and outer guards. The apparent craft recovery’s only part of the story.

- 9) Haut says he saw bodies outlined under a tarp, with “oversized heads protruding.” He guesstimated size as that of a “10 year old child,” going on to say that Col. Blanchard, by holding his arm four feet above the floor in his office, indicated the height of the beings.
- 10) Haut confirms that a temporary morgue was set up, which nicely dovetails with the call to Glenn Dennis wanting several child coffins and dry ice for apparent preservation.
- 11) Fortunately for all concerned, none of the recovered material was radioactive.
- 12) Right after he got back from Carswell, Major Jesse Marcel personally and irately informed Haut of the switcheroo from real crash debris to the prosaic weather balloon wreckage done by General Ramey while Marcel was briefly out of General Ramey’s office. Thereafter, the matter was never discussed again.
- 13) Haut mentions that he would be permitted to “make at least one visit to one of the recovery sites during the military cleanup.” Further, he’d be allowed to collect some of what was recovered and display it in his office. Weirdly, he doesn’t say whether he actually did either.
- 14) The thoroughness of evidence retrieval and site cleanup is evidenced by his statement that two separate teams were used and revisited each site months after the primary cleanup.
- 15) Where in the 1993 Affidavit Haut mentioned only a craft, here he used an expanded formula, “craft and crew.”

Thus, by comparing the two affidavits, it is readily evident that Walter Haut not only knew all along there was a coverup regarding the craft debris littering Mac Brazel’s ranch, but was directly involved in creating and disseminating a cover story which hid the far more significant, maybe even vital information of the recovery of a separate, mostly intact craft at the second site. Further, Haut constitutes another primary eyewitness to many hotly disputed prior aspects of the story, such as the bodies, their size and characteristics.

From a historical standpoint, Haut has greatly broadened the research possibilities regarding Roswell, for we now have a whole new batch of people and their survivors to interview, documents to pore over. ■

IVAN’S LIBRARY

Continued from Page 30

ened to the city’s endless ability to charge admission to just about every building of interest. So the lost underground might prove another rich revenue source. Unfortunately for the mayor, the only new discovery was a tunnel filled with skeletons—the victims of Ivan IV’s secret police.

Underground tourism so far has been confined to the underground shopping malls that contain Moscow’s most posh shops.

Modern media in Russia is still emerging from the twentieth century during which any form of dissent or exposé could earn a one-way ticket to Siberia. Stories of the secret subway have made their way into the tabloids and it is claimed that thousands are employed in both the secret transportation system and a secret city to which it connects six miles away. While the tabloid media is seldom reliable, a portion of the subway that connects the Kremlin to Moscow’s airport is no longer a secret. It is, however, open only to government officials.

The people cynically regard this secret subway as “Metro 2,” although officials of the FSB (the successor to the KGB) are not amused. Journalists who have openly mentioned it have been subject to interrogation.

Moscow’s Diggers

Modern urban explorers, though, are braving the threat of government and are illegally transversing their city underground. They call themselves the “Diggers” and despite the military actively patrolling some of the complex tunnel system, they bravely risk arrest and subsequent consequences. Sewers, subway stations, and even the newly constructed underground shopping malls provide access to the subterranean world of catacombs, tunnels, bomb shelters and secret vaults.

While the city has granted access to the tunnels to a handful of tour operators, the military is equally concerned with a terrorist group penetrating beneath the Kremlin. In 1988 near the Spasskiye Gate of the Kremlin a construction project found a treasure hoard dating from the late Viking period. The works of both Scandinavian and Russian

jewelers included items never found before in Russia, and most likely hidden during the Mongol invasions were part of the discovery.

Must the world wait for another construction incident for the library to someday be unearthed? The founder of the Moscow Diggers, Vadim Mikhailov told the *Ottawa Citizen* that he firmly believes that the treasure will someday be found. He claims to have more information than anyone alive. His greatest source is a ninety-year-old nearly-blind man nicknamed Appolos who claims to have found it. His poor treatment at the hands of the government is his reason for depriving the government of the location of this literary treasure.

Vadim and his group have broken



Subway station
on the Moscow Metro
(Photo by Pete Verdon)

through an underground brick wall directly into the Kremlin’s Palace basement, now moldy from the flowing waters. They have found skulls, weapons, deserted passageways and dry water courses. They have even found radioactive material lying beneath the Moscow State University and alerted the government. They have also been threatened on occasion by the darker side of modern Russia: Gypsies, drug addicts, alcoholics, homeless families and ex-convicts. On one occasion the group aided police in recapturing three escaped murderers. On another they instructed Moscow’s elite Alpha unit on how to navigate the sewage tunnels to end a hostage crisis in the Dubrovka Theatre.

Will Vadim and the Diggers someday uncover the secret vault of Ivan’s library, or will a future construction project uncover the priceless collection? What is fervently believed, at least by those who have investigated this treasure, is that it still exists, far below the Kremlin. ■

Continued from Page 33

somewhat interchangeable): 1) Mental phenomena, such as telepathy, clairvoyance, and precognition; and 2) Physical phenomena, such as psychokinesis (the moving of objects without any physical connection, without any muscular or mechanical action or known intervening material or energy) and levitation. (Physical paranormal phenomena are discussed in my forthcoming book *The Parapsychology Revolution*, which I compiled with Logan Yonavjak).

The significance of crisis apparitions and similar cases of apparently spontaneous telepathy lies not just in statistical arguments that, on the whole, they must be more than chance coincidence. In particular, two other lines of evidence are also extremely impressive as support for the reality of such spontaneous psi. The French astronomer and psychical researcher Camille Flammarion (1842-1925) and the parapsychologist Louisa Rhine (1891-1983) collected hundreds and thousands of cases of spontaneous psi along telepathic lines (indeed, the number of cases Louisa Rhine had on file numbered in the tens of thousands; admittedly, however, Flammarion and Rhine did not apply the same rigorous standards for determining authenticity as was used for *Phantasms*). Like



ATLANTIS RISING ONLINE ADVANTAGE
 Download Current and Past Issues Exclusively at
www.theUFOstore.com
SAVE UP TO 50% OFF NEWSSTAND PRICE

<p>DOWNLOAD THE CURRENT PDF ISSUE 2 WEEKS EARLY AND SAVE 50% JUST \$2⁹⁵</p>	<p>SUBSCRIBE 6 - PDF ISSUES (ONE YEAR) AND SAVE 40% JUST \$14⁹⁵</p>
<p>DOWNLOAD PAST PDF ISSUES JUST \$2⁹⁵</p>	<p>SUBSCRIBE 12 - PDF ISSUES (TWO YEARS) AND SAVE 40% JUST \$24⁹⁵</p>

ATLANTIS RISING IN .PDF FORMATTED DOWNLOADS

Download Current and Past Issues Exclusively at www.theUFOstore.com

the authors of *Phantasms* and the "Census of Hallucinations," Flammarion and Rhine found that there are elements and patterns common to most of the cases (and, when viewed cross-culturally, such commonalities persist), and these do not fit the standard preconceived cultural notions of "ghost stories," suggesting the veracity of most reported incidents.

Perhaps even more compelling is the work of various modern researchers that has demonstrated a weak but persistent correlation between low levels of geomagnetic activity on planet Earth and cases of apparent spontaneous telepathy (based on cases going back to the latter half of the nineteenth century). This, in my opinion, is a very strong argument supporting the contention that there is something genuine to the concept of "crisis apparitions." It suggests that spontaneous telepathic psi is real and natural and, as might be expected of a natural phenomenon, its manifestation is influenced by other natural parameters. Alternatively, are we to hypothesize that hundreds of hoaxers over nearly a century and a half have conspired to fake crisis apparitions in identical correlation with geomagnetic activity? This latter hypothesis strikes me as rather far-fetched, if not downright ludicrous.

Note that a correlation between geomagnetic activity and spontaneous telepathy does not necessarily imply that the "telepathic signal" is magnetic or electrical in nature.

The human brain is influenced by magnetic and electric fields, and whatever may be the carrier of the telepathic signal, the transmission, reception, and manifestation of the message by the brain could be hampered or enhanced by differences in the magnetic and electric fields that the brain is subjected to.

For many people a phenomenon is not "real" unless it can be duplicated in a laboratory setting under controlled conditions. Being a natural scientist and field geologist, I have never agreed with this contention. After all, can we create a genuine volcanic eruption in the laboratory or even on command in the field? Until about two centuries ago the scientific community routinely rejected the concept of rocks falling from the sky (meteorites). Still, attempting to induce, capture, observe, and experiment with apparent telepathy under controlled conditions is a worthy endeavor. Unfortunately, however, to this day it is fraught with problems and, though numerous experiments have tested positive for apparent telepathy, others have had negative results and replication is a persistent problem. The bottom line is that we really do not know exactly what parameters make for good telepathic transfer, much less how to control for them.

In the late nineteenth century, accompanying the work on spontaneous cases of telepathy, members of the SPR were undertaking experiments in "thought-transference." Experiments included a percipient (receiver) guessing words or playing cards that an agent (sender) was concentrating on. Statistical analyses applied to such experiments clearly indicated that more information than would be expected by chance was being transferred between the individuals involved. However, in hindsight (as even admitted in some cases by the experimenters not many years afterwards), many of the experiments did not impose rigorous enough controls and it now appears clear that cheating and fraud were involved in at least some instances (indeed, some of the subjects subsequently admitted to cheating). Personally, while I feel that many of the cases of spontaneous telepathy collected by the SPR stand up to careful scrutiny, to be on the "safe" side, I would not accept any of their early experiments as carrying evidential value for telepathy.

A new era in the application of experimental methods to the problem of telepathy opened in the early 1930s with the work of Joseph Banks Rhine (1895-1980; husband and scientific partner with Louisa Rhine mentioned above) at Duke University. Although he tried other methods first, the mainstay of Rhine's early work was the use of specially designed cards that came in

packs of 25, with five each bearing the following symbols: circle, square [or rectangle], plus sign, star, and wavy lines (often referred to as either ESP cards or Zener cards, after Rhine's colleague Dr. K. E. Zener who designed them). In a typical experiment, an agent (hidden from the percipient) would focus on each card in turn drawn from the top of a randomly shuffled Zener deck. The percipient would guess the card. Working through a complete deck in this manner, it was expected that one would on average call on the order of five cards correctly by chance, and indeed this was the case for most subjects. But Rhine found some individuals who could consistently call six, seven, or more cards correctly in a deck. Rhine also ran experiments in which the percipient called the cards down through a deck, from top to bottom, without the deck being touched by anyone. Afterward the calls were checked against the deck, and in these cases, too, certain individuals could consistently rise above chance expectation.

In his card calling experiments, Rhine initially distinguished between telepathy (where apparently the percipient received the thoughts of the agent) and clairvoyance (where the percipient appeared to somehow

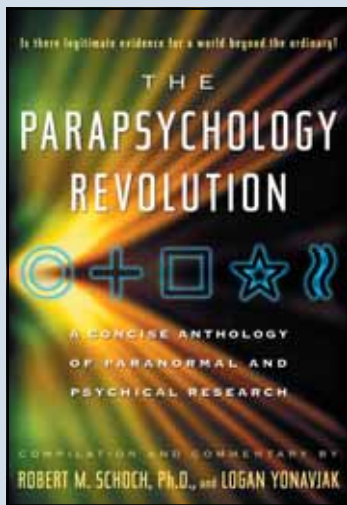

Available in February

ATLANTIS RISING MAILING POLICIES

A regular subscriber to Atlantis Rising (for either 6 or 12 issues) is mailed each new issue directly from the printer at the time of publication. Address labels go directly on the cover, with no additional packaging. Such mailings are sent 4th class to the U.S. postal system only.

We now offer FOREIGN and FIRST CLASS U.S. SUBSCRIPTIONS (to be airmailed in envelopes within a few days of publication).

These subscriptions will be charged the additional regional flat rate for postage required, plus a service charge to cover the envelope and office expenses which we incur in order to provide these services on a relatively small scale. Should we experience sufficient demand, we may at some time be able to reduce the service charge.

Subscription Category	additional postage per iss.	service charge per iss.	Total Subs Charge
Regular U.S. (4th class, no envelope)			
6-issues	0	0	\$ 24.95
12-issue	0	0	40.00
First Class U.S.			
6-issues	\$ 2.00	\$ 2.00	\$ 48.95
12-issues	2.00	2.00	88.00

Existing regular U.S. subscribers wishing to convert to first class may do so by sending us an amount equal to \$3 for each of their remaining issues. To determine the proper amount call our toll free number at 800-228-8381 during business hours (Mountain time) Monday through Friday.

Canada (airmail only)			
6-issues	\$ 2.85	\$ 2.00	\$ 54.05
12-issues	2.85	2.00	98.20
Mexico (airmail only)			
6-issues	\$ 4.00	\$ 2.00	\$ 60.95
12-issue	4.00	2.00	112.00
Western Hemisphere (Except Can. & Mex.) (airmail only)			
6-issue	\$ 7.20	\$ 2.00	\$ 80.15
12-issue	7.20	2.00	150.40
Europe (airmail only)			
6-issue	\$ 7.20	\$ 2.00	\$ 80.15
12-issue	7.20	\$ 2.00	150.40
Asia & Africa (airmail only)			
6-issue	\$ 7.20	\$ 2.00	\$ 80.15
12-issue	\$ 7.20	\$ 2.00	150.40
Pacific Rim (airmail only)			
6-issue	\$ 7.20	\$ 2.00	\$ 80.15
12-issue	\$ 7.20	\$ 2.00	150.40
Australia (airmail only)			
6-issue	\$ 7.20	\$ 2.00	\$ 80.15
12-issue	\$ 7.20	\$ 2.00	150.40

Foreign orders for other products which we sell will have the appropriate postage added to the bill. In the case of back issues, foreign orders will be charged an additional 50¢ per issue plus the appropriate postage.

be aware of the symbols on the cards directly). But it was quickly realized that in practice it was virtually impossible to distinguish between telepathy and clairvoyance. In the so-called telepathic experiments, the percipient could be “reading” the cards directly. If we accept the concepts of precognition and receiving information telepathically from the future (and there is evidence for such, but that is beyond the scope of this article), then the percipient in a so-called clairvoyance experiment might actually be receiving infor-

The Egyptian Goddess Hathor

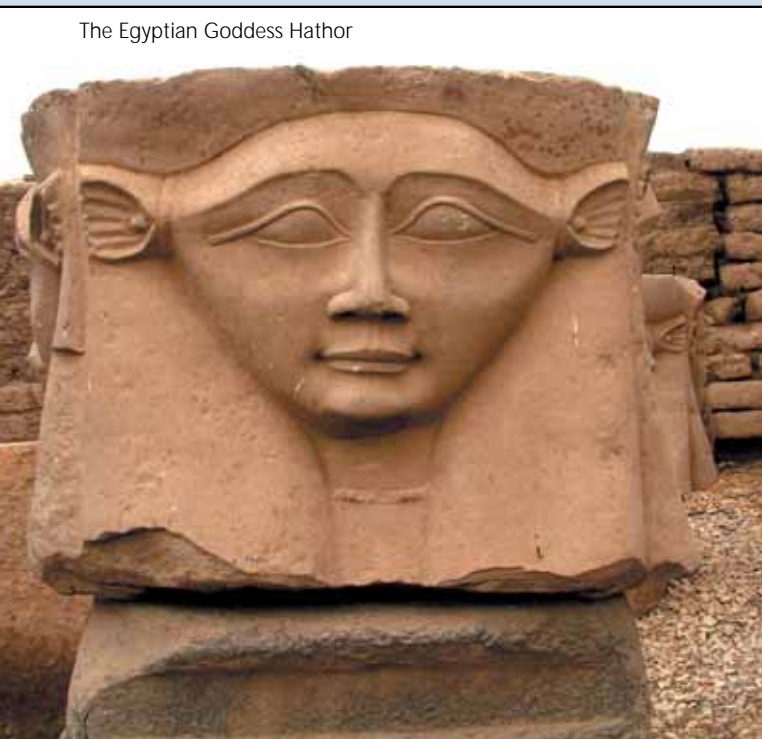

mation telepathically from the future when the cards are checked by a human mind. As a general term to encompass both telepathy and clairvoyance, Rhine popularized the term “extrasensory perception” (originally written as extra-sensory perception, and commonly abbreviated as ESP).

Over the years numerous researchers in different labs duplicated Rhine-type experiments, many getting statistically positive results. Sets of Zener cards were also sold to the general public, and in the late 1930s and 1940s testing for ESP was a popular sport. Masses of data were collected, and it seems clear that at least in some cases information was “leaking through” by paranormal means (that is, outside of the known means of acquiring information by the recognized senses). Not only have Zener cards been used, but pictures, videos, images, and emotions have been sent “telepathically” with statistical significance to percipients while fully awake and aware, while in a relaxed state with mild sensory deprivation, or while asleep. However, decades of such experi-

ments have done little more than establish that there is “something” there. How to consistently invoke and control mental psi phenomena remains elusive. Likewise, though various theories to account for psi have been proposed, including theories based on quantum physics, none have generally been accepted even among parapsychologists (those who professionally study psi phenomena).

In my opinion it might be fruitful to focus more serious attention again on spontaneous cases of psi. Additionally, I believe it is important to explore further the physical parameters that may enhance or impede psi experiences. As already mentioned above,

spontaneous psi correlates with geomagnetic activity. It has also been found that incidents of psi correlate with Local Sidereal Time (which relates to the position of the horizon at any particular point on earth relative to the center of our galaxy).

In my studies of ancient temples, shrines, and other sacred sites, I have come to the conclusion that often they were purposefully designed and situated to enhance psi experiences. There is suggestive evidence that at many ancient temples, such as the Temple of Hathor at Dendera, Egypt, among other practices, signs and messages (interpreted as

from the deity) would appear in dreams of sleeping supplicants, imparting veridical, but otherwise unknowable, knowledge. That is, I believe in at least some cases psi experiences were being purposefully induced. Psi experiences, religious ecstasy, and mystical revelation appear to be intimately entangled (a topic for another essay). By studying the factors common to genuine time-honored sacred sites, I believe we may be able to more closely circumscribe the principles involved in eliciting strong psi experiences. When it came to psi, I suspect that various ancient and so-called primitive cultures had a much better grasp of the subject than society at large does today. ■

Robert M. Schoch, a full-time Boston University faculty member, earned his Ph.D. in geology and geophysics at Yale. He is best known for redating of the Great Sphinx of Egypt. He takes a serious scientific interest in the paranormal. His forthcoming book is The Parapsychology Revolution (Tarcher/Penguin). Web site: www.robertschoch.com

Continued from Page 37

firing ceramics, deploying nutrition and herbs and all things for the benefit of the people.

And all based on revealed cycles of time.

Scientists today will cleverly remark the correlation of the sunspot cycle with drought and famine in India; and there the matter rests. Or exotic viruses and fevers are blithely blamed on global warming, so-called. How does this compare with the ancients who, foretelling seasons of fever and pestilence, set about draining the marshlands or applying themselves to irrigation projects when the prophets foresaw a time of drought?

Sky-time also predicted atmospheric densities (a’ji) measured by the ode and her multiples; and these were noted spiritually by the North American Indians in their sacred round huts:

Algonquin: Let man build consecrated chambers that My spirits may come and explain a’ji, and they shall be provided against famine and pestilence. – *Oahspe/Book of Saphah*

Estimates based on the fall of a’ji were the weather forecasts of the day, predicting even spells of darkness. Related calculations—“coming under certain numbers: 11, 33, 66, 99 and so on”—deduced periods of arbitration and destruction, of order and anarchy, of plenty and famine, of inspiration and superstition, of peace and war. These tables of prophecy appear in *Oahspe’s “Book of Cosmogony and Prophecy,”* but are still largely undeciphered. Their rhythms, though, seem to resonate with well-known chronologies, such as the Yankee timetable of aggression, as seen in American military history.

Kii Tablet: In the years of a’ji, mortals become warriors.

The span of time from the Texas Alamo (1835) to the outbreak of the Mexican War (1846) was eleven years, i.e., one ode. Indeed, the Mexican War (expansionist and unprovoked, giving us half of the American West) broke out thirty-three years (one spell) after the heat of the War of 1812. Later, the blood-and-lust of the Civil War, the War of Rebellion, as these intervals march on, ended precisely thirty-three years (one spell) before the onset of the Spanish American War, which was the next impulse to conquest, giving us the Philippines, Puerto Rico, Cuba, etc.

Early in the 20th century, two odes of peace followed the Great War, only to be answered by World War II. The space between the Korean War and Vietnam was an ode. The two Gulf/Iraq wars were also separated by an approximate ode.

Third Rule of Prophecy (99 years): the post-War boom, 1947-48, was a sunspot year with an output of magnitude greater than had been seen in a hundred years. Powerful were the historical currents of that peak year: Gandhi liberated India; the Jewish state

Continued from Page 39

columns bordering a gigantic wreath honoring German soldiers killed in battle. This fantastic scene was captured in the now famous documentary, *Triumph of the Will* by legendary film photographer Leni Riefenstahl. Where did those 160,000 perfect young soldiers come from?

In October of 1935, Hitler supplied the answer to that riddle when he made public that he had kept 21 infantry divisions “under wraps” in 1934, and he announced that they would now become the core of the new German army—the Wehrmacht. So that’s where the 160,000 came from, but where did the 21 divisions come from? An infantry division can be as many as 20,000 troops, so it seems that somehow Hitler magically got his hands on an instant army of about 500,000 soldiers, with no explanation of where they came from or how they had been trained. He announced also that an additional 21 divisions would soon be added. One may be forgiven for wondering just how was it possible for all this to be accomplished only one year after Hitler became chancellor of Germany? Now that we have evidence of alien involvement in the war preparations, a startling explanation presents itself. It is now believed by many that the aliens have mastered cloning biotechnology, and in fact that the small grey ETs of abduction fame are clones themselves. Could it be possible that Hitler’s alien friends presented him with a ready-made million-man army of cloned storm troopers? We have already seen that the planning for World War II probably began in the early part of the century. Was Hitler’s army secretly growing up in spaceships or underground cities even as real soldiers were dying by the

millions on the battlefields of Europe? Perhaps George Lucas knew more than is commonly believed when, in 2001, he wrote Episode II of the Star Wars saga titled *Attack of the Clones*.

When it comes to fantastic possibilities for the Nazi/ET connection, though, that is only the beginning.

A Nazi Moon Base

According to Vladimir Terziski, the Germans succeeded in reaching the moon sometime in 1942, and established a base on the dark side. Terziski is a controversial figure in the UFO community, but he has impressive credentials. He is a Bulgarian-born engineer and physicist. He graduated cum laude with an MS degree from Tokai University in Tokyo, and reportedly is conversant in Eng- >



Hitler at Nuremburg

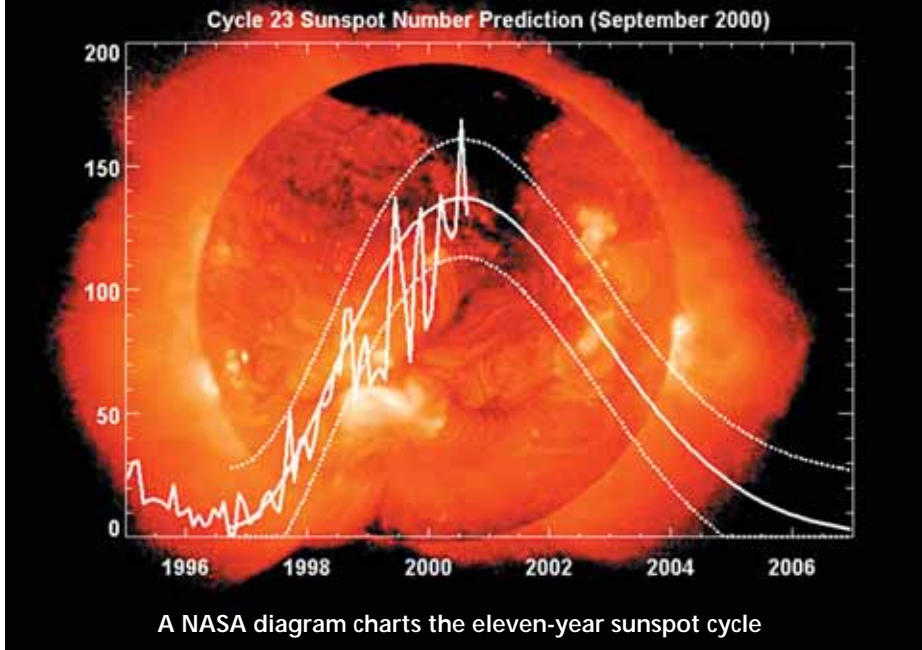

A NASA diagram charts the eleven-year sunspot cycle

was established in Palestine where, that same year, the Dead Sea Scrolls were exhumed from centuries of rest. In America, the OAS, CIA, Air Force and Defense department were established. The first celebrated UFO flap occurred that year as well. The 1848 discovery of gold in California would now be echoed by the 1948 discovery of gold in Africa.

Working back from the post-War years, under the centennial unit (Third Rule of Prophecy): 1848 was a crashing year, bringing: worldwide “home-rule” revolutions; the gold rush; first women’s rights conference (Seneca Falls); and the end of the Mexican War, whose treaty ceded us the whole Pacific Coast up to the 49th parallel.

Following the rhythm back another 99 years, the mid-century mark in Europe (ca. 1750) saw the discovery of the ruins of Pompei and the height of the enlightenment—Voltaire, Rousseau, Diderot, even Ben Franklin, all rising to fame, and all sounding the death knell of age-old monarchism and the tyranny of kings.

Another cycle back: 1648 distinguishes itself as the year set, by Kabbalists, for the coming of the Messiah.

1548 distinguishes itself as the moment of the reformation.

1450 distinguishes itself with the Plague, marking its own centennial, returning to ravish Italy. Ninety-nine years earlier, of course, the Black Death had moved all across Europe reducing the population by one half and changing absolutely everything.

Called the Year of the Flying Birds by the Chinese 16 centuries before Galileo, the sunspot maximum is a definite, measurable, even spectacular phenomenon. But as meteorological folklore, it ranks high and for two reasons: first, because its origin on the surface of the sun itself is an apperency, probably a mistake; and second—thanks to the present vogue of symptom-gazing here in the United States of Amnesia (thanks, G.V.) – side-effects (“spots”) are hailed as causes, and

true causes are all but forgotten, ignored, or never discovered.

Still: It was during the most recent sunspot year that, at the height of atmospheric turbulence (July 14, 2000), shortwave communications were completely shut down on earth. With satellites focused on the magnetosphere (earth’s power station), European Space Agency (ESA) scientists actually detected the basis of that surge: compression of the magnetosphere (Van Allen Belt). This rounding or “deforming” or compressing of the magnetic belt is the long-missed force behind odic events on earth. Earthquakes conforming to the “cluster-years” of the ode can now be traced to the vigorous compressions in earth’s own magnetic field. And what causes disturbances in earth’s power grid every eleven years (automatic garage doors even opening and closing on their own)?—The planet’s own electromagnetic dynamo, its field, is sufficient. Sun-worshiping purveyors of solar causation will, in good time, sink into oblivion, and in the ascendant will arise the science of field, heralded by Einstein and now completed by fresh generations of truth-seeking scientists. With rediscovery of the Egyptian ode, the key player will be field itself, the magnetic envelope of earth, the shape-changing vortex or womb of the planet. It will not be the far-away sun, but variations in vortexya that will yield the true calculus needed on Mother Earth to prosper her insecure brood. We will not need other planets or other stars or mythical “gods” like solar wind prodigiously hurling thunderbolts of supercharged particles at little earth. Or bugbears like “dangerous solar radiation.” All we need is the humble science of earth’s home and surroundings. Her field. And it is—in the cosmic scheme of things—right in our own backyard. ■

Susan Martinez’s book, The Psychic Life of Abraham Lincoln, (Career Press/New Page Books) is now available.

lish, Japanese, Russian and German in addition to his native Bulgarian, and is therefore uniquely able to do research in all these languages. He says, "The Germans landed on the moon probably as early as 1942, utilizing their larger exo-atmospheric rocket saucers of the Miethel and Schriever type.... The Schriever Walter turbine powered craft was designed as an interplanetary exploration vehicle. It had a diameter of 60 meters, had 10 stories of crew compartments, and stood 45 meters high." Terziski claims that after establishing the initial surface base they tunneled underground, "and by the end of the war there was a small Nazi research base on the moon. The free energy tachyon drive craft of the Haunibu-1 and 2 type were used after 1944 to haul people, materiel(s)(sic) and the first robots to the construction site." He claims that the moon has an atmosphere, water and vegetation, and it is possible to get around without space suits, despite NASA propaganda to the contrary. If Terziski is right, it seems reasonable to suspect that the aliens played a large role in the Nazi moon adventure. While obviously this fantastic accomplishment would have had little wartime strategic value, it should be remembered that, in 1942, the Germans were supremely confident of winning the war, and were projecting their space travel (conquest?) plans



Vladimir Terziski

well ahead into the thousand-year Third Reich.

A Proxy War

Needless to say, sources of information about extraterrestrial involvement in WWII in book form are hard to come by but *Exopolitics* is the title of at least two large books, one by scholar Michael Salla and another by former Carter administration staffer Alfred Webre. But still, if you want details on how the alien factor sorts out, you must go to the Internet where a veritable cornucopia of such information presents itself. Whether such material is to be relied upon is, of course, another question, but that has not slowed the production of complex scenarios arguing for consideration of alien involve-

ment in the politics and wars of earth. Among those offering supposedly detailed information concerning the extraterrestrial intervention factor typical is someone called "Branton." All we know about him is that he claims to have been abducted many times since the age of 12, and that his information accords with David Icke and some other such sources. The following is taken from Branton's material: *A formal treaty was executed in 1933 between the Nazi-Bavarian Intelligence Agency, which eventually became the S.S, and the "Greys," an alien race living in underground bases in Tibet and elsewhere in the world, facilitated by the Thule Society. The Greys are said to be from Zeta II Reticuli. The Greys, in turn, it is said, are subservient to the Reptilians, and are believed to be implanted with biochips to keep them under control. They are mostly a cloned race, having lost the ability to reproduce aeons ago, due to radioactive fallout from nuclear wars on their home planet. There is a group of about 2000 original Grey prototypes from which the clones are copied. Many abductees have commented on their robotic, totally unemotional behavior. The Reptilians are a fierce, tyrannical race from Alpha Draconis, sometimes referred to as Reptiloids because they are human-like in basic form, but their skin, it is claimed, is scaly, and their faces are lizard-like with vertical-slit eyeballs. They are up to 8 feet tall, and very strong. They are considered by some extraterrestrials to be master geneti-*

ATTENTION COLLECTORS

ATLANTIS RISING
 BACK ISSUE ASSORTMENT PACKAGES
 NOW AVAILABLE!

GET THEM WHILE THEY LAST AND SAVE A LOT!

20 Miscellaneous Issues just **\$89** + \$9.95 S.&H.

10 Miscellaneous Issues just **\$46** + \$7.95 S.&H.

5 Miscellaneous Issues just **\$24** + 5.95 S.&H.

PRICES APPLY TO PRESELECTED ASSORTMENTS ONLY—NO SUBSTITUTIONS PERMITTED
 Assortment orders do not count toward our standard 10% discount on orders over \$100

Send Check or M.O. to ATLANTIS RISING • P.O. Box 441 • LIVINGSTON, MT 59047 or call 800-228-8381

BodyPrayer
 Creative Relaxations
 To Soothe Your Soul

A Guided CD by Cynthia Logan, CMT
 \$12.00 (\$2.00 from each sale donated to Red Cross Disaster Relief Fund)

Mail Check to:
 1128 S. Spruce Drive, Bozeman, MT 59715
 Phone Orders: 406.586.8968
 E-mail: wordlady@imt.net

cists, but others claim that they have botched many of their genetic experiments. Their most powerful capability is mind control, and in this they are considered undisputed experts. This accounts for their ability to “shapeshift,” or to take on a human appearance, because they can plant that illusion in the mind of the observer. They are in league with other Reptilian races from Rigel Orion and Bellatrix Orion. Together they are referred to as the Draco-Orion Imperialists, and have taken over many of the star systems in the 21 star cluster in this section of the Galaxy, comprising the Draco-Orion/Grey Empire. The Draco-Orionites are referred to as “interventionists” because they boldly seek to enslave other races. Like the fascists that they sponsored, they are cruel and merciless.

Their ancient enemies are the humanoid races from Andromeda, Arcturus, Lyra, the Pleiades and Sirius. The main Pleiadian faction is from the planet Erra circling the star Taygeta, one of the Seven Sisters. Taken together, this group of civilizations comprises the Galactic Federation. The DAL Universe is also part of the Federation. The Federation races are “non-interventionist” in that they believe deeply in freedom, and will never try to influence or persuade other developing races, or to block or violate their right to make free will choices, and, in fact, they seek to assist in spiritual development. The Federation forces on earth are based under Death Valley and Mt. Shasta in California. The star wars began when the Draconians attacked Lyra and the Pleiades. Branton says, “The stories that contactees tell of the devastating battles and galactic massacres—in almost every case initiated by the collectivist-interventionist reptiloids/greys—between the two galactic superpowers are integral although controversial elements within the annals of Ufology.”

Whew.

Tesla

While the Draco-Greys, it is claimed, gave the Germans fantastic weapons including jet propulsion, rocketry, television-guided missiles, anti-gravity aircraft, nuclear technology, and possibly even a cloned army, the allies were not completely without alien assistance. The ETs, it is said, gave the Allies one man—Nikola Tesla. It was Tesla, according to this line of argument, who first saw the promise of radar in 1917, and was instrumental in its development and use in the war. Consequently, the British and the U.S. had sophisticated radar defenses deployed early in the war using Tesla’s patents, while the Germans gave it scant attention, and it was radar that won the Battle of Britain. Tesla and Roosevelt met in 1917 when FDR was Secretary of the Navy, and Roosevelt was very impressed with Tesla’s genius. In 1936, according to some reports, he put Tesla in charge of the Invisibility Project, working with the navy. In 1940, as the story goes, they succeeded in making a ship disappear in

**TESLA, AT 78, BARES
NEW 'DEATH-BEAM'**

Invention Powerful Enough to Destroy 10,000 Planes 250 Miles Away, He Asserts.

DEFENSIVE WEAPON ONLY

Scientist, in Interview, Tells of Apparatus That He Says Will Kill Without Trace.

Nikola Tesla, father of modern methods of generation and distribution of electrical energy, who was 78 years old yesterday, announced a new invention, or invention, which he said, he considered the most important of the 300 made by him in his life.

He has perfected a method and apparatus, Dr. Tesla said yesterday in an interview at the Hotel New Yorker, which will send concentrated beams of particles through the free air, of such tremendous energy that they will bring down a fleet of 10,000 enemy airplanes at a distance of 250 miles from a defending nation's border and will cause armies of millions to drop dead in their tracks.



Times Wire Photo Photo.
NOTED INVENTOR 78.
Nikola Tesla.

The New York Times Story on Tesla's "Death Ray"

the Brooklyn Navy Yard. Whether or not invisibility was secretly used in the war is unknown. Tesla also invented, it is claimed, particle beam weaponry which he publicly referred to as the “Death Ray.” It was not, it seems, developed soon enough to use in the war, but satellite-based versions have since, it is believed, become potent weapons in both U.S. and Soviet arsenals. Tesla is also said to have been offered a large amount of money to go and work for Germany but that he refused, and that he remained an American patriot to the end. Tesla often made mention of his “off-planet” friends, say some. Sometime in the mid-thirties, they say, he arranged a meeting between Roosevelt and Pleiadian representatives, which supposedly took place on a ship in the Atlantic. Within the alien-tracking Internet community it is believed that some sort of agreement came out of that meeting, and that a Federation representative may have consulted at the Pentagon for most of the war.

Suicide Mission to Mars?

Sometime in late 1944, the story goes, when it became apparent that they had lost the war, the Germans moved the main components of their antigravity aircraft technology and their top scientists to their subterranean base in the Antarctic called Neuschabenland, which they had been preparing since 1938. It is suspected that an extraterrestrial base had already existed there, and that it was inhabited by their compatriots, the Draco-Orionites. The Germans had been assiduously patrolling and defending the sea lanes to Antarctica since early in the war as they moved men and materials there in U-boats. They stationed their largest battle cruiser, the Graf Spee, off the coast of Argentina some time in 1939, and they were known to be sinking even merchant vessels sailing in those waters. If true, this might explain why the Allied armies found only superficial remnants of flying

disc development as they overran Germany, and none of the important scientists. Could Antarctica have been the destination of the so-called “Lost Battalion” of 250,000 German troops that could never be accounted for? Could these have been perhaps carefully kept and maintained cloned storm troopers, to be used as genetic prototypes for the new Wehrmacht?

By April of 1945, the European war was winding down as the Allied troops converged on Berlin. At that point, it is claimed, all the antigravity technology and scientists had been transferred to Neuschabenland. It was from that Antarctic base that the Germans decided to launch a mission to Mars, jointly with the Japanese. Vladimir Terziski says, “According to the authors of the underground German documentary movie from the Thule society, the only produced craft of the Haunibu-3 type—the 74 meter diameter naval warfare dreadnought—was chosen for the most courageous mission of this whole century—the trip to Mars.” The trip reportedly took almost 8 months because the

large Andromeda-type tachyon drives were turned off immediately after the escape from the earth’s gravitation, and the ship coasted the rest of the way in an elliptical orbit. Terziski believes that the crew probably numbered in the hundreds. The huge craft crash-landed on Mars in January, 1946 severely damaging the tachyon drives and making return impossible, but according to the documentary, the crew knew from the beginning that it was probably a suicide mission. Terziski says, “The radio message with the mixed news was received by the German underground space control center in Neu Schwabenland and by their research base on the moon.” Evidently, with the war on earth lost, the Axis partners decided to position themselves off-planet in readiness for the next round, and the advent of the Fourth Reich.

All the chroniclers of World War II agree that the German soldiers were very tough and courageous, and almost robotic in terms of efficiency. They obeyed orders without question, even in the face of certain death. As the Blitzkrieg rolled over Europe, they could do no wrong. It was their insensitivity to human suffering that made the atrocities in Russia, and the concentration camps (the Einsatzgruppen were taken from the ranks of the Wehrmacht), possible. Maybe, though, it wasn’t that they were sadistic—maybe they just didn’t care! But, on the other hand, they showed no resourcefulness, whereas the British and American soldiers could be relied on to come up with ideas even in the worst situations. Ultimately, the thinking soldier with a heart prevailed. Apparently, the moral of the story is—if you expect to win a war with an army of clones, you better have someone with great intelligence directing them, and Hitler just didn’t fill the bill. When it came to intellect, he was no match for the combined brain power of Franklin Roosevelt, Winston Churchill, and an allied army of citizen soldiers from free societies. ■

Continued from Page 41

the first professionally authenticated Viking site in the New World, at L'Anse aux Meadows, today a National Historic Park. Even more intriguing, the late epigrapher Dr. Barry Fell demonstrated a fascinating parallel between Micmac birch-bark characters and ancient Egyptian script. What, if anything, these possible prehistoric themes may have had to do with the lost Stone Cross of southern Newfoundland, French was not sure, but she was determined to find it.

Basing her work primarily on old legends, she compiled a rough map that took her inland from the Bay du Nord and over the high cliffs of Devils Dining Table. On their opposite side, in a barren plain surrounded by hills thick with spruce trees, she found the object of her quest. It was spread out on the arid ground, the huge outline of a diamond-shaped cross, as though it were opening itself up from the center. Measuring 30 feet from north to south, it more closely resembled a compass. The design was encircled by a ring of numerous white stones, some of boulder proportions and others piled into rough heaps, mimicking crude towers or the abstract configuration of statues. From the vantage-point of one of these piles, French could make out the faint image of a man upon the

cross, not in a crucified position, but as though he were emerging from the diamond opening. She remembered a Micmac tradition concerning these stones: It was permissible for a visitor to remove one, to keep it for his own healing purposes, so long as he replaced it with another. Two stone basins lay near the south end of the structure, one perhaps for ablutions, the other for donations; in the latter she found several old coins, a single example dated 1865.

Although French had discovered (perhaps re-discovered) the Stone Cross, she found no answers to her questions: How old was it? Who made it and why? Who was the last to see it before us? What illnesses had been cured? How many had been truly healed? Beyond these enigmas, she experienced a feeling of profound wonder, a sensation of being in a sacred zone, a sacrosanct area with an emotional character all its own that was not frightening, but certainly powerful. If the Stone Cross of Newfoundland is Norse, its diamond shape renders it a most peculiar Christian design occurring nowhere else, its compass-like configuration might refer to a kind of "Christ-of-the Mariners" for Vikings far from home, even if that

home were only L'Anse aux Meadows. It could also pass for an icon of that other people who supposedly impacted the Micmacs, the ancient Egyptians. For them, Ausar (better known by his Greek name, Osiris), the man-god of resurrection, was a proto-Christian concept associated with the Cross of the Four Cardinal Directions. Despite the presence of a male figure, the Newfoundland Cross is not a crucifix. Whether Christ or Osiris, or someone altogether different, the man received homage in the recent past, judging from the coins left at the site as apparent offerings. But Micmac traditions establish a prehistoric origin for the cross.

With a population of 56,000, Moncton is



Peticodiac River tidal bore

A NEW BOOK FROM THE FORBIDDEN ARCHEOLOGIST

In his characteristic style of meticulous documentation and research, Michael A. Cremo offers a fresh and scientifically-based perspective on human origins, with an emphasis on state-of-the-art consciousness studies. Take a fascinating tour through enigmas of time and space, ranging from Precambrian microfossils to black holes to the planets of demigods, and discover how we devolved from pure consciousness to this earthly realm.

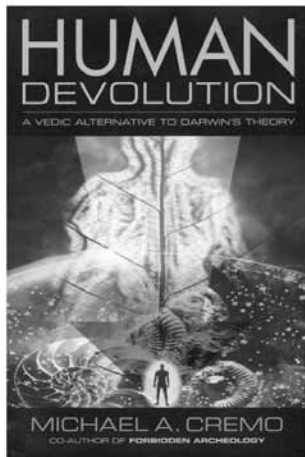

Human Devolution A Vedic Alternative to Darwin's Theory

The sequel to *Forbidden Archeology* by Michael A. Cremo, *Atlantis Rising's* featured "Forbidden Archeologist" columnist!

\$35.00

6"x9", hardbound, 584 pages
To order, call
Torchlight Publishing toll free:

1-888-867-2458

Mention this ad and receive
FREE SHIPPING!

"A new world paradigm for healing work."

"Bridges ancient knowledge with modern science and chi awareness—both mystical and practical."

"Detailed descriptions of the healing rituals and technology used on Atlantis, with the Essenes, and by native shamans."

"Includes breathwork, sound and light applications, water purifications...in-depth how-to's for modern self-healing and longevity—awesome!"

HEAL YOURSELF
with
Breath,
Light,
Sound &
Water

\$17.95 (+ S&H)

170 pages
fully illustrated
8 1/2" x 11"

to order,
contact the author
Denis Ouellette

**PREVIEW—
download
first few
chapters
FREE!**

Call 406-333-4103

Order online—

go to www.integralbreathwork.com



Moncton's Magnetic Hill

New Brunswick's second largest city and long an important communication hub. But its status as a venerable rail center and maritime headquarters has nothing to do with its otherworldly significance. This rather unprepossessing metropolis with elegant Victorian Hotels (the Beausejour and Canadiana are the most charming in the province) features two different, apparently unrelated phenomena of nature in extremis. Observers standing in Bore Park, at the east end of Main Street, witness a twice-daily occurrence which most dramatically takes place around the vernal and autumnal equinoxes. This is the world's highest tidal bore, caused by the tides of the Peticodiac River accelerated by those in the Bay of Fundy. Converging shorelines here and an upward sloping bottom give it the configuration of a funnel.

As the tide enters, the water must only go up. From an optimum vantage point, the bore begins to spread across the inlet in a soft hush, steadily gathering momentum into a dramatic roar. Although usually from a few inches to only a foot, the tidal bore sometimes rises to over 50 feet (at the nearby Minas Basin) in a deafening crescendo. As the locals describe the tide, "sometimes it's impressive; sometimes it's not." A bore timetable is on public display in the park.

Visitors in search of Moncton's other natural curiosity should either drive or bicycle to the corner of Mountain Road (126) and the Trans-Canada Highway. There, they will experience a dimensional warp, an inexplicable fold in the fabric of space, an optical illusion to defy reason, where gravity seems to operate in reverse. What appears to be an upgrade is actually a downgrade. The marvel was first noticed seventy-five years ago, when drivers of the earliest automobiles in Moncton, while driving to the bottom of the hill, appeared to coast back up to the top when they let off the brakes. A billboard erected by the city at the spot reads, "Welcome to Magnetic Hill! Proceed to sign ahead for natural phenomenon." Interested visitors should drive down the slope until they reach the bottom, then cross to the left side of the street and stop at the white post. From this spot, turn off the ignition, put the gear in neutral, release the brakes and your

car will magically coast on its own up the same slope back to the top.

More than seven decades of investigation have failed to adequately explain what people experience. Baffling as Magnetic Hill may be, it is not unique. Other examples have been found in Ontario (outside Darce, southwest of Renfrew, and near Hamilton, in Burlington) and in Quebec (at the eastern townships and in Montreal). But the Moncton Hill is most pronounced in its effects. Investigator Andrew Tomas writes that Moncton's hill is not actually "magnetic," because materials other than iron are similarly affected by its forces. Objects of wood or rubber behave identically and even water has been seen to flow up-hill at the site. He quotes several out-of-town tourists, as well as local people, who report sensations of vertigo or nervousness when near the hill: "There is something here in the ground. You feel it in your bones." Tomas speculates that pursuing the mystery may someday unlock the secrets of anti-gravity, the propulsion system by which UFOs are believed to operate.

French researcher Jacques Bergier takes a more esoteric approach to Magnetic Hill. He writes that it is a dimensional portal to another level of existence created by a powerfully negative "mascon" beneath the city, and is focused at the intersection of Mountain Road and the Trans-Canada. A mascon is a concentration of exceptionally dense material (in this case, iron) just below the surface. He also describes an entire Indian settlement in the area that vanished during historic times.

Indeed, there are Native American folk traditions of individuals and whole villages which have disappeared. And such tales are not confined to the new world. The ancient Egyptians believed in the concept of the "false door" as part of their funerary practices. In the tomb was placed (and specially set up and empowered according to criteria since lost) a sealed door, or sometimes just the sculpted rendering of a door, through which the spirits of the departed may travel from this life to the next and back again. In this book's chapter on New York, we sited the Thompson Park Lines, where inter-dimensional shifts still occur, while the Irish concept of "stray sod" describes a similar phenomenon.

Moncton's Magnetic Hill appears to be a survival of these ancient, worldwide "secret doors" to levels of being beyond our own. How they may be spiritually accessed is part of a lost wisdom and, consequently, the site should not be trifled with. Its chief value today lies in the bridge it forms between our material existence and that alternate universe, a bridge not easily crossed perhaps, but important to demonstrate the reality of that universe. ■

How Much Did the Ancients Know?

Technologies of the Gods

THE CASE FOR PRE-HISTORIC HIGH TECHNOLOGY



Now a breakthrough video from the creators of *Atlantis Rising* magazine takes a look at real evidence—largely ignored by the academic establishment—which shatters the orthodox scenario for the dawn of civilization on Earth. Now assembled in a devastating one-hour documentary, hosted by *Atlantis Rising* editor and publisher J. Douglas Kenyon, are the comments and evidence of breakthrough researchers such as **John Anthony West, Robert Bauval, Richard Noone, Colin Wilson, John Michell, Patrick Flanagan, Christopher Dunn, Zecharia Sitchin, David Hatcher Childress, Edgar Evans Cayce** and others.

1 Hr. DVD **\$24.95**

or VHS **\$19.95**

+ \$5.95 S.&H.

To Order Call

800-228-8381

Continued from Page 43

countless hurricane-driven tsunamis, 30 feet and higher, have swept across the islands. In the 1950s, an attempt was made to form a small community on the southernmost Joulter's island, but it was abandoned when a hurricane destroyed the small, wood-framed homes. All of Joulter's is extremely shallow and boats with a draft of more than two feet cannot reach it.

From directions given by the locals, we found the underwater wall with Eslye and Krista Brown. We had to enter the area during high tide as we sped over a mile of water only one foot deep. We found the wall exactly as described by the Andros resident. She related that she had seen it twice. The first time, in the early 1990s, a large portion of the wall was intact. She saw it the second time after a severe 1990s hurricane and said that the eye of the hurricane hit that area and destroyed most of the wall and shoreline.

The wall was primarily made from square and rectangular limestone blocks that ranged in length from 3-6 feet, a width of 2-3 feet, and a thickness of 6 inches to 3 feet with some blocks far larger. The blocks are obviously cut and roughly dressed and tool marks are clearly visible. One area of the wall remains fairly intact and is found in water about 6 feet deep. Brushing the sandy bottom underneath the lowest tier of stones revealed more limestone blocks under the visible portion. How far down it extends is unknown. This section of the wall runs approximately 30 feet and is formed by the massive blocks stacked on top of each other with 2-3 layers of blocks visible. We found about 50 large stone blocks widely scattered in water around this intact portion as if they had been tossed around by huge waves. Another area of the wall may also be intact, but it is different. This section is made from identical blocks, but they form a nearly square area about 20 feet wide. In general, the top of this square formation is flat and has two layers of blocks. We later looked at this area on modern satellite images, and were astonished that the square area of blocks was quite visible. We found more of the blocks extending off the island in a line over 300 yards long. Most of these were almost completely covered by sand.

On the same island we found two small dams made from stone stuck vertically into the bottom. These dams were at the end of long tidal estuaries and were apparently used as fish traps. Bahamian fishermen related that they never built such traps and always used netting. On the other hand, it was a common practice by the Maya. On the next trip there we explored the island end to end. The island has black and white rock. Curiously, four red rocks were found. At the highest two points on the island, on wide and flat areas about 30 feet high, there were piles of small square and rectangular blocks.

These seemed to be ideal as building materials, but they were lying in jumbled masses.

June 2007 Andros Expedition

Another week-long expedition to Andros was conducted in June by Greg and Lora Little accompanied by Greg's 82-year-old father, Paul. The trip began with a more extensive aerial survey to identify more dark features in other areas of the Great Bahama Bank. Just over 20 of these were found and all but one were subsequently visited on boat along with the Browns.

Dark underwater features on the Great Bahama Bank

A wide range of findings were made while investigating 20 of the dark underwater features off Andros on the Bahama Bank. Some were formed from dumped bombs, dozens of propane cylinders, and appliances, while several others were formed from stone. One formation, a 500-foot-long form shaped like an eye, had the remains of an old wooden boat in a white spot in its center. Another 500-foot-long feature, also shaped like an eye, had the remains of a crashed plane in its white center. The plane may be a Cessna 210, upside down. A retractable nose wheel

landing gear was removed and brought to the boat. Both of these formations were more than 40 miles offshore. In addition, we had obtained our own side-scan sonar, converted it into a portable unit, and used it to examine several of the spots formed from stone to determine the amount of stone and its layout. However, one of the underlying principles in the Atlantis Project is to find things that are definitive, thus these stone formations are of marginal interest to us.

Other planes and a Bermuda Triangle mystery solved

Three crashed planes, found on Andros, were investigated. One reason that Greg's father Paul went was that he was a WW-II flyer (PBYs) and experienced pilot. One plane, a DC-3, was reached after a grueling 2-hour trek through dense mangrove swamps. Another, the remains of a twin-engine Beech, was found at Morgan's Bluff. We interviewed the individual who had dredged it from the bottom in 1989. Finding no bodies in it, he bulldozed it into the jungle. No investigation had ever been done. A host of serial numbers from plane parts were obtained and an FAA staff member is investigating them hopefully to determine the plane's identity. The re-



Lora & Greg Little



White marble building apex after it was cleaned of debris and coral. It is over 7 feet long and is at least 3 feet thick. Square marble blocks are strewn around it.



Tip of an anchor extending from the bottom in a white spot at a dark feature on the Bank.

One of the most intriguing formations on the Bahama Bank is this 500-foot-long spot. Note the material in the white center. The Littles are not releasing information on which specific spot contained the sunken wooden boat.

mains of a small plane's tail, from a Cessna 172, was found at Red Bays. Investigation of the remaining ID on the tail showed that it was from a plane that reportedly disappeared in the Bermuda Triangle in 1968—off Grand Turk. Curiously, the tail was found nearly 400 miles from where the plane disappeared, but the strong currents would have eventually carried it to that area where it eventually washed ashore. While we know this solves one Bermuda Triangle mystery, it doesn't show the cause of it.

More research at the Joulter's Wall

Two more days were spent investigating the wall at Joulter's Cay and exploring the islands. Clear water allowed us to take over 4 hours of underwater video of the wall. This time we also explored more of the blocks found further off shore. We believe the wall was at least several hundred yards long, but its purpose is completely speculative. We spoke to several Andros fishermen who were over 80 years old. None of them knew its possible purpose or who built it. One resident simply said, "It's always been there." The initial impression is that it might have been a retaining wall of some sort, but the entire area is so shallow that the bringing in of

large boats or barges is simply impossible. We have also done extensive research in journals and magazines from the Bahamas, but it remains a mystery—an intriguing one.

June 2007 Bimini Expedition

An expedition to Bimini was conducted in late June to perform side-scan sonar on the known underwater formations there. Our side-scan sonar unit provides a high-resolution image of the bottom that allows precise measurements to be made on stone. Large portions of the Paradise Point Pier, first reported in 2006, which looks nearly identical to the Bimini Road (except it is well elevated off the bottom), has numerous stone columns scattered on it. We were also able to verify with the side-scan that complete and partial circles formed from huge stone blocks are present at Proctor's Road. These appear to have been mooring circles, in use when the sea levels were about 8 feet lower.

Marble building remains found.

About 7 miles north of Bimini we were led by Krista and Eslie Brown to what appeared to be a small pile of stone in 28-feet of water. The side-scan sonar revealed that

sand was actually covering a widely dispersed area of stone. We managed to completely clear off one of the coral-encrusted blocks and were astonished to see that it was actually an ornate, well-polished triangular apex of a building. It looked like the top of a temple. A small piece of the well-made slab was removed and it proved to be high quality white marble, shining like quartz in the sun. More work revealed long columns and beams of marble, some of which were over 15 feet long before their ends disappeared under the sand. Many other huge slabs of marble were found. It appeared that either one of two things was there. Either a marble temple had been built there and collapsed, or a boat carrying a marble temple had sunk there. But there was no evidence of a boat. Scouring written records a few days later, we found that in 1970, Richard Wingate had found the same formation and determined that a boat was under three layers of marble blocks and slabs. This is found in his 1980 book, *Lost Outpost of Atlantis*.

Donato's rectangles investigated—possible building remains seen and photographed

Utilizing our side-scan sonar and GPS, we quickly found the rectangular formations off Bimini in 100 feet of water, which Bill Donato first found in his November 2006 project. We dropped a weighted marker buoy directly into one of the rectangles. Eslie and Krista Brown dove the spot and explored the area, taking several photos. The rectangular forms consist of elevated stone on the bottom that has been covered by thick layers of coral. Several of the photos clearly show what seem to be building blocks, some of which are embedded vertically into the bottom. In short, these forms appear, at face value, to be building foundations of some kind. These rectangular forms lie uniformly on a ridge running for at least a mile and a 10-foot drop-off is adjacent to them. This drop-off leads to a narrow flat area that then descends quickly. Found about 10 feet above the 10,000 B.C. shoreline, they raise intriguing possibilities related to Cayce's statements about Atlantis and Bimini.

What's Next?

Obviously, many of the finds described have to be thoroughly researched. A more extensive investigation into the underwater rectangular formations at Bimini is planned for the near future. A search for historical records of the underwater wall at Joulter's Cay is ongoing. Preliminary exploration of the Berry Islands has already begun, but wasn't described herein. It is anticipated that extensive explorations will begin in the Berry Islands in 2008 along with more expeditions on the Great Bahama Bank, both in air and on water. In addition, 2003 expeditions on Andros found at least 4 other crashed planes, but these were not directly investigated. Some of these may well be aircraft that "disappeared" into the Bermuda Triangle and in 2008 we should know if that is the case. ■

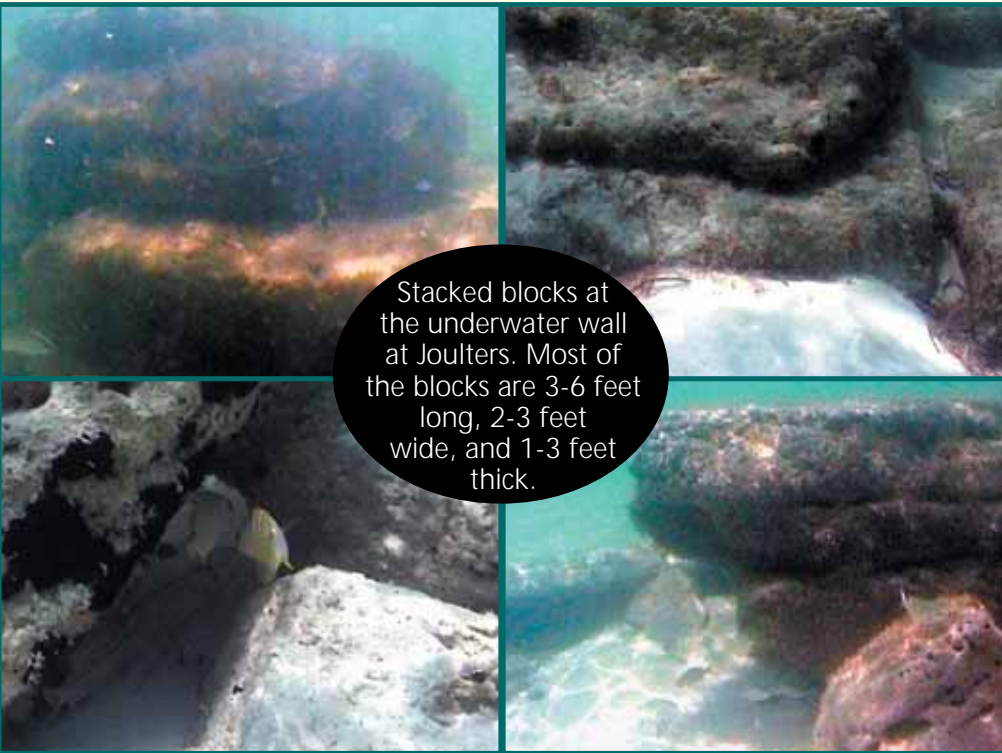

Stacked blocks at the underwater wall at Joulter's. Most of the blocks are 3-6 feet long, 2-3 feet wide, and 1-3 feet thick.

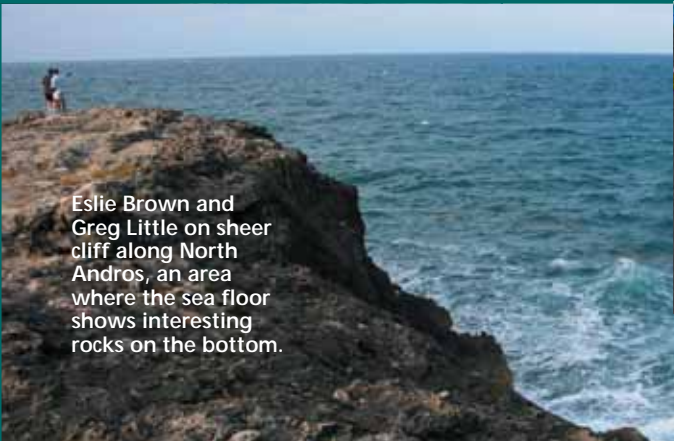

Eslie Brown and Greg Little on sheer cliff along North Andros, an area where the sea floor shows interesting rocks on the bottom.

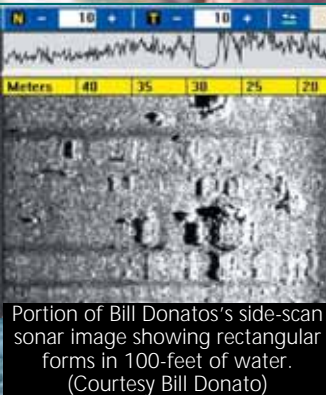

Portion of Bill Donato's side-scan sonar image showing rectangular forms in 100-foot of water. (Courtesy Bill Donato)

Continued from Page 44

about, which in turn determines how you feel; how you feel determines what you think about, as well as your behavior, and how you behave determines what you think about (is that a 'Catch-22?'). This Über-Body—E-B for short—has, of course, a left and a right side, just like our physical body does. And we supposedly access only seven to twelve percent of E-B, just as we only use about ten percent of our brain's capacity. For most of us, E-B is lopsided; the right side, which holds what we're conscious of, is markedly smaller than the left, and relates to what Smith calls 'the first field of awareness.' The larger side holds all that is unconscious, and relates to the 'second field of awareness.'

The goal, similar to Jung's process of individuation, is to unite the two and move into a third field of infinitely larger possibilities (chaos theory's combo of opposites spiraling into a "third thing" comes to mind). In this reality, we would "Be Here Now" and directly perceive our world, leaving behind the tendency to create "mirror bubbles" that reflect back to us our interpretations and judgments of that world. By expanding what we're conscious of, we can experience alternate realities. (Great with analogies, Smith likens this to attending college; for most, the experience opens doors to new thoughts, feelings and behaviors that create new world-views). But it's when we enter the third field (which contains everything outside E-B) that we encounter truly transforming energies.

No stranger to transformative experiences, Smith grew up in a military family and, as a child, almost drowned in Lake Michigan. He remembers a vague form approaching him as he stopped struggling underwater, enveloping him in a sense of peace. Pulled to safety, he recalls seeing his father standing next to his mother after he was brought home. Later, he learned his father had not been there. After the accident, his life felt "lackluster"; psychic comic books provided a few bright spots. When he was in high school, his family moved to Virginia Beach, where the Edgar Cayce Foundation is located. In the metaphysical library of the Association for Research and Enlightenment (A.R.E., the Cayce 'sister' organization), he researched a term paper on the lost continent of Atlantis, giving his fertile young mind exotic food for thought. His path took him, at 17, into the U.S. Navy. While serving in Vietnam, Smith found himself merely thinking of where he wanted to be transferred, only to be given a set of orders directing him to just that place, a phenomenon that occurred numerous times. Back in the U.S., he experienced emotional malaise as well as internal bleeding that sometimes left him hospitalized. Facing invasive surgery, he practiced the exercises in Castaneda's books and experienced respite. "Don Juan's Toltec world has given me physical, mental and

spiritual renewal," says Smith. "His teachings literally saved my life." While apprenticing with don Juan, Smith earned degrees in education and journalism, pursued graduate work in religious studies, and served on the A.R.E. staff and then at the Monroe Institute (where sound technology is used to facilitate the exploration of consciousness).

Currently the Communications Director for the Institute for Therapeutic Discovery in Virginia, Smith considers himself a very ordinary guy, holding down a serious job, leading a completely normal life. But he may "knock out 20 hours of meditation on the weekend," which for him means "dreaming," occasionally visiting alternate realities (he's been to the moon and has experienced himself as a tornado and as a lizard, among other things). The tall, slim Smith says he has "dazzling crystalline eyes that are completely bloodshot." He's a tech-geek who sneaks in a Southern accent now and then, along with the truly '70s expression, 'far out.' But he's not, really. For all his dreaming and traveling, Smith is extremely down to earth—grounded, he would say. He isn't out to have psychedelic experiences, but focuses on connecting with what you might call the Will of God. "I have a problem with 'creating your own reality'—take the energy of desire and use it to get more in touch with how God created you, nurture that and let it grow." He doesn't drink alcohol, and says he tries to eat well, but moderately. "I'm going out to Burger King as soon as we get off the phone, he informs me. "Come on, a Junior Whopper?" No worries; he'll walk or swim it off. He loves living in Virginia with both the mountains and the ocean nearby, and enjoys experiencing the four seasons. His daughter is "the best part of the joy in my life" (Smith's upcoming book will address 'Toltec parenting').

While *Toltec Dreaming* requires some serious mental processing, it is clearly written, and alternates conceptual material with personal anecdotes and comments on don Juan's transmissions, as well as many practical exercises for "controlling your internal cohesions," thereby shaping your external world. The work is influenced by more than Smith's experiences with the Toltec seer; including talks with people who have had Dreaming Body Experiences (DBEs), the perusal of the Edgar Cayce psychic readings and his own explorations. As a result, he has come up with a three-step process for inducing a dreaming state. "This '3E' method focuses on expectation (opening perception), excitation (balancing perception) and exploration (focusing perception). "A major theme

in the Cayce readings is that as you develop spiritually, you shed the binding and restrictive forces isolating you in a three-dimensional, physical reality," notes Smith, who offers another set of procedures "to exercise the dreaming body" and prepare for a conscious DBE. One of these—Too Tired?—grabbed my attention right away. Try this:

1. Allow your fatigue to saturate your physical body. This facilitates relaxation and the notion that it is OK to be fatigued.
2. Perceive a hollow core at the center of your physical body.
3. From that core push or expand the fatigue energy outward in all directions. As you do so, the core of the energy also expands.
4. Contract that energy. The core of the energy will contract as well. Exhale as you expand the energy away from you; inhale as you retract the energy.
5. As you fall asleep (attention, insomniacs!), expand and contract your fatigue energy at your own pace. As you expand and contract the energy, know within yourself that you are doing so in order to build dreaming intent.

Many of the exercises are designed to help access cues from the physical body. Smith thinks that if significant numbers of people could access their 'body-wisdom' and achieve deep relaxation, humanity might be able to mitigate a point of no return, known to military pilots as QNR. "We may be there," he says, immediately mitigating his own statement:

"But, if humans made it, they can temper it with actions like those Al Gore recommends. We need to develop a natural balance with nature; right now we're taking and pooping, not taking and giving back."

Ken Smith advocates developing and harnessing personal power for the purpose of unity with the God-Self, the Field, the Eagle of the Toltec world, and for creating a full, balanced life that is an inspiration to others and a boon to the planet. With both feet on the Earth, dare to soar beyond its bounds. Live in the world well, but be not tethered. "Dreaming is a land of potential, a no-money-down virtual reality technology," he promises. "Anything can happen, and often does! Ordinary reality is but one dream, as is non-ordinary reality." Shakespeare said it through Prospero in *The Tempest*: "We are such stuff as dreams are made of, and our little life is rounded with a sleep." And of course, Hamlet's famous soliloquy, "To sleep, perchance to dream..." conjures a sobering reality indeed. As Smith repeatedly advises, clarity and intent are prerequisites for healthy altered states. Before embarking, take a reality check. But do row merrily, for Life, after all, is but a Dream. ■

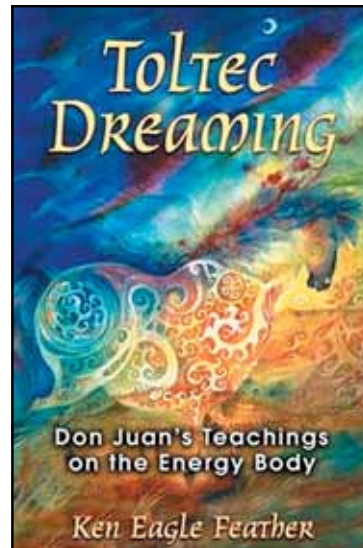

Continued from Page 47

published their research report, near-death experiencer Dannion Brinkley published his *Saved by the Light*. Brinkley described how, when horrifically struck by lightning and technically “dead” for 28 minutes, he found himself in a crystalline “cathedral of knowledge” where “beings of light” granted him 117 glimpses of possible future events. Brinkley later reported that, by early 1998, 95 of these events had come true.

A century earlier, in 1896—ten years after his brush with death and at the beginning of his career as a fiction writer—Wells wrote the short story *Under the Knife* in which the patient-narrator, slipping out of his body during surgery, careens around the physical universe undergoing what sounds very much like a near-death experience.

In 1906 Wells wrote a short story, *The Door in the Wall*, that, while not mentioning death till the end, contains many of the critical details of a near-death experience as they were to be set forth in works like *The Truth in the Light* and *Saved by the Light* close to a century later. These details would not be known until the last decade of the twentieth century, when medical science had advanced to the point where victims could sometimes remain “dead” for periods of as long as a half-hour before they were resuscitated.

As Wells’s *The Door in the Wall* begins, the narrator, Wallace, then aged five or six,

finds himself standing in front of a mysterious green door. He wants to go in, but feels “either it was unwise or it was wrong of him.” Yielding to the temptation and entering, he finds himself in a gorgeous garden with “something in the very air of it that exhilarated... something in the sight of it that made all its color clean and perfect and subtly luminous.”

The boy proceeds down a wide path and meets three beings: two panthers who now escort him, and a “tall, fair girl” who he meets at the end of the path and who picks him up and kisses him. The girl leads him to a “spacious, cool palace” where he experiences a timeless interlude of events and game-playing, every detail of which he will forget. A second triad of beings appears: “two dear playfellows who were most with me” and “a somber dark woman, with a grave, pale face and dreamy eyes...who carried a book, and [led me] into a gallery above a hall.” The woman opens the book and, the narrator tells us, “in the living pages of that book I saw myself.... in it were all the things that had happened to me since ever I was born.”

This apparent classic NDE life review becomes vaster: “Then, I turned the pages over, skipping this and that, to see more of this book and more, and so at last I came to myself hovering and hesitating outside the green door in the long white wall, and felt again the conflict and the fear.” The boy begins to turn this final page and is stopped by the woman. They struggle; the woman yields; the boy no sooner sees the page when he finds himself no longer in the enchanted garden but in “a long gray street in West Kensington, ...weeping aloud... because I could not return to my dear playfellows who had called after me, ‘Come back to us! Come back to us soon!’”

The boy has returned to grim reality, and all through his life he will long to return to the en-

chanted garden. He chances upon the green door three more times. Each time he does not enter, feeling that entry is somehow forbidden. Each of these occasions has found him hurrying to a rendezvous that is crucial to his worldly success; to linger in the garden would be to jeopardize his career.

As the story draws to a close the narrator—perhaps; we will never know—yields to this vision that seems to reflect his very soul. He disappears, and his body is found in an excavation shaft. Apparently he has fallen through a construction doorway.

Wells later wrote about *The Door in the Wall*: “I am more than half convinced that he [Wallace] had, in truth,

an abnormal gift, and in a sense, something—I know not what—that in the guise of wall and door offered him an outlet, a secret and peculiar passage of escape into another and altogether more beautiful world. At any rate, you will say, it betrayed him in the end. But did it betray him? By our daylight standard he walked out of security into darkness, danger, and death.”

So sharply near-death experience-like—if brilliantly masked—is this account, that we must ask ourselves if Wells himself didn’t actually have such an experience, one that provided him with a profound vision of the future, and one which most likely took place at Holt. Perhaps he did not consciously remember it. If he did remember it, Wells would most likely never have spoken about it: A working class upstart who penetrated to the highest levels of Britain’s upper-class intelligentsia, he would have been chary of revealing anything about himself that might cast doubt on his sanity. Moreover, in general Wells revealed little of his personal life. A notorious philanderer, he did not allow his autobiographical account of his countless love affairs, *H.G. Wells in Love: A Postscript to an Experiment in Autobiography*, to be published until every woman mentioned in the book had died. (The last to go was famed author Rebecca West in 1984.)

The list of contemporary events and (often New Age) ideas anticipated by Wells in his writings also includes: astral traveling, in *The Plattner Story* (1896); remote viewing, in *The Mysterious Case of Davidson’s Eyes* (1894); past-life regression and “future-life progression,” in *The Dream of Armageddon* (1901); and even “cargo cults,” in *Lord of the Dynamos* (1894). How can we account for such prescience? Is genius enough? Only if genius includes bursting the bonds of time and space. ■



Dannion Brinkley

**Give Your Friends the Books and Videos that Everyone is Talking About
If You Can't Find it Here Check Our Previous Issues or Call Us.**

BOOKS Alphabetically by Title

BIOLOGY OF BELIEF *Dr. Bruce Lipton*—This groundbreaking work in the field of New Biology by Dr. Lipton (former medical school professor at the University of Wisconsin and research scientist at Stanford University School of Medicine) has previously been offered in VHS/DVD format. Here, finally, is the written format. His experiments, examining in great detail the molecular mechanisms by which cells process information, have revealed that genes do not, in fact, control our behavior. Instead, genes are turned on and off by influences outside the cell. These influences include our perceptions and beliefs.

6 x 9 H/B, 224 pp., B&W photos & drawings \$25.00

BLOODLINE OF THE HOLY GRAIL *Laurence Gardner*—“Special Author’s Edition,” 4 NEW CHAPTERS—From royal and suppressed archives comes proof of the descending heritage of Jesus in the West. Penetrating new light is cast upon the Grail Code of Service and the venerated feminine element, abandoned by the Church in order to forge a male dominated society.

P/B 454 pp, 24 col. pl., 10 B&W fig., & 15 B&W charts \$18.95

CAPTURED! The Betty and Barney Hill UFO Experience—The True Story of the World’s First Documented Alien

Abduction Stanton Friedman and Kathleen Marden—In this book you’ll get an insider’s look at the alien abduction, previously unpublished information about the lives of the Hills before and after Barney’s death in 1969, their status as celebrities, Betty’s experiences as a UFO investigator, and other activities before her death in 2004. Kathleen Marden, Betty Hill’s niece, shares details from her discussions with Betty and from the evidence of the UFO abduction. She also looks at the Hills’ riveting hypnosis sessions of their time onboard the spacecraft. In addition, Friedman, the original civilian investigator of the Roswell incident, reviews and refutes the arguments of those who have attacked the Hill case, including the star map Betty Hill saw inside the craft and later recreated.

6X9 P/B, 320 pp., 24-30 Photos/Illus. \$16.95



CAVERNS, CAULDRONS, AND CONCEALED CREATURES: A Study of Subterranean Mysteries in History, Folklore and Myth

(EXPANDED & REVISED)
Wm. Michael Mott—This is the first book of its kind

in terms of truly going in-depth to examine the striking similarities between folklore, religious, mythic, new age, fictional, and first-hand witness or historical accounts of cryptid and reptilian figures. Drawing from scientific facts, folklore and comparative mythology, and anecdotal sources, it is demonstrable that the structure of our planet is not quite what we have been led to believe. Our species has perhaps experienced, through the ages, encounters and conflicts with “others,” non-human intelligences or beings of various types who have seldom been our friends, and such encounters are continuing today.

6X8, 440 pp., color and B&W Illus. \$28.95

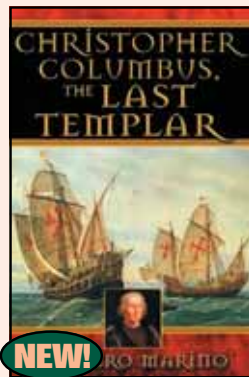

CHRISTOPHER COLUMBUS, THE LAST TEMPLAR
Ruggero Marino—According to the historic documents and maps revealed by Ruggero Marino, Columbus shared their dream of Christians, Muslims, and Jews living in peace in a New Jerusalem, and his voyage across the Atlantic was also to find the place where the New Jerusalem could be

built. Marino reveals that Columbus studied ancient texts and maps from the Vatican Library, access to which was granted by Pope Innocent VIII—who Marino shows to be Columbus’s true father. Innocent VIII (whose own father was Jewish and grandmother was Muslim) was the perfect individual to further the Templars’ plan to create a universal religion combining the spiritual wisdom of the three faiths. Marino shows that Innocent’s “disappearance” and the story that Columbus merely stumbled onto the New World were part of a calculated political and theological cover-up that has lasted for over 500 years.

6X9 P/B, 392 pp., 8-pg. color insert \$19.95

COSMIC WAR: Interplanetary Warfare, Modern Physics and Ancient Texts

Joseph Farrell—No other region in North America features the variety and intensity of unusual phenomena as that found in the world’s largest alpine valley, the San Luis Valley of Colorado and New Mexico. Since 1989, Christopher O’Brien has documented thousands of high-strange accounts that report UFOs, ghosts, crypto-creatures, cattle mutilations, skinwalkers and sorcerers, along with portal areas, secret underground bases and covert military activity. This mysterious region at the top of North America has a higher incidence of UFO reports than any other area of the continent and is the publicized birthplace of the “cattle mutilation” mystery.

6X9 P/B, 392 pp., Illus. \$19.95

CYGNUS MYSTERY: Unlocking the Ancient Secret of Life’s Origin in the Cosmos *Andrew Collins*—The Cygnus Constellation is the key to unlocking humanity’s ancient and universal belief that life originated in the heavens—and will ultimately return there. Best-selling author Andrew Collins has found that this long-held conviction emerges from an astronomy that is about 17,000 years old, with standing stones, temples, and monuments across the globe oriented towards Cygnus’ stars. He also discovered that the use of deep caves by Paleolithic man was crucial to the rise of religious thought and the belief in life’s stellar origins. Modern-day technology has now confirmed the existence of high-energy particles in these caves...particles that come from a binary star known as Cygnus X3. These ancient people already knew what science is finally confirming—that the DNA of life originally came from deep space.

6X9 H/B, 368 pp. \$24.95



EGYPT CODE *Robert Bauval* (*The Orion Mystery, The Secret Chamber; The Mars Mystery, and Talisman each with Graham Hancock*)—Much has been written as to “how” the Egyptians might have aligned their monuments with such high precision, but the question that has always remained unanswered is “why”—why did the ancients put so much emphasis on astronomical alignments? And what could be the function, practical or symbolic, behind these mysterious alignments? This book is unlike any other book before it and covers the whole of Egypt’s ancient civilization in a manner never before attempted.

6X9 H/B, 288 pp. \$44.95 (from overseas)

END OF DAYS: Armageddon and the Prophecies of the Return *Zecharia Sitchin*—Ever since Sitchin in his trailblazing book *The 12th Planet* brought to life the Sumerian civilization and its record of the Annunaki—the extraterrestrials who had come to Earth from their planet Nibiru, fashioned mankind, and gave us civilization and religion—questions have abounded. Are the ancient gods still here, or did they leave? Will they return? What will happen then? Will there be another deluge or apocalypse when Nibiru meets Earth? What about “Planet X” and the Mayan 2012? What about Jesus? In this, Sitchin presents compelling new evidence that mankind and its planet Earth are subject to a predetermined cyclical Celestial Time.

6X9 H/B, 336 pp. \$25.95

END OF TIME: The Mayan Prophecies Revisited *Adrian Gilbert*—According to the ancient Maya, the world as we know it will end on December 22, 2012. On that date, their calendar will click around to zero for the first time in over 5,000 years. They prophesied that this destruction will be preceded by a series of natural disasters. Gilbert revisits the ancient Maya sites and makes astonishing new discoveries. He also makes use of modern computer technology to backtrack the skies to the way they would have appeared in previous ages, which has resulted in some major findings concerning the astronomical significance of the Mayan calendar.

6X9 H/B, 336 pp., illus., photos \$49.95

ETIDORPHA: Strange History of a Mysterious Being and an Incredible Journey Inside the Earth

John Uri Lloyd—This is one of the best classics on the hollow earth. Most people are familiar with Jules Verne’s account of a journey to the center of the Earth, but not as many enthusiasts of science fiction or fantasy literature are conversant with this forgotten classic, a tale that describes the adventure of a man who joins a secret society for the purpose of publishing a book describing this organization’s beliefs and rituals. When he publishes the book, the society kidnaps him, transforms him into an old man, and sends him on a journey into the interior of the earth on a spiritual mission. Join this student and his adept guide on an alchemical journey to the “end of the Earth.”

7x8 P/B, 342 pp., B&W drawings \$19.95

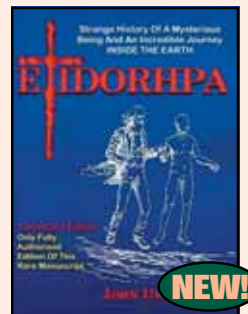

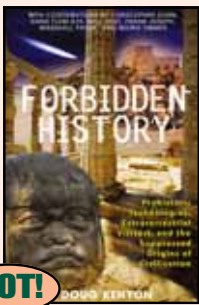

FORBIDDEN HISTORY: Extraterrestrial Intervention, Prehistoric Technologies, and the Suppressed Origins of Civilization

Edited by J. Douglas Kenyon—In 42 articles from Atlantis Rising, Kenyon has carefully built a compelling collection of material in support of today's growing challenge to such outmoded ways of thinking as Darwinism and Creationism. What emerges is a thoughtful case for a much greater antiquity for civilization, as well as a convincing argument for the existence of advanced technologies in pre-history. Through it all appears the vast, yet unmistakable, outline of a lost fountain-head for world culture.

6 x 9 P/B, 352 pp., many photos both B&W & Col. \$18.00

HOT!

FORBIDDEN RELIGION: Suppressed Heresies of the West

Edited by J. Douglas Kenyon—Following the model of his bestselling *Forbidden History*, Kenyon has assembled from the pages of *Atlantis Rising* material that explores the hidden path of the religions banned by the orthodox Church—from the time before Christ when the foundations of Christianity were being laid to the tumultuous times of the Cathars and Templars and the Masons of the New World. Revealed in this investigation of the roots of Western faith are the intimate ties of ancient Egyptian religion to Christianity, the true identities of the three magi, the link forged by the Templars between early Christianity and the Masons, and how these hidden religious currents still influence the modern world. This book serves as a compelling introduction to the true history of the heretical religious traditions that played as vital a role in society as the established faiths that continuously tried to suppress them.

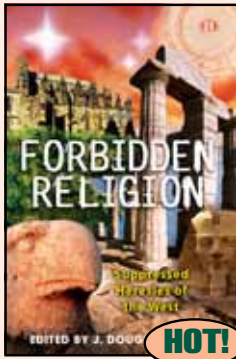

HOT!

6X9 P/B, 344 pp., 8-pg. color insert and 100 B&W Illus. \$18.00



GENIUS OF CHINA: 3,000 Years of Science, Discovery and Invention *Robert Temple*—The ancient Chinese were the first to discover the solar wind and the circulation of the blood and even to isolate sex hormones. From the suspension bridge and the seismograph to deep drilling for natural gas, the iron plough, and the parachute, ancient China's contributions in the fields of engineering, medicine, technology, mathematics, science, transportation, warfare, and music helped inspire the European agricultural and industrial revolutions. Based on the immense, authoritative scholarship of the late Joseph Needham, the world's foremost scholar of Chinese science, and including a foreword by him, this revised edition brings to life the spirit and excitement of the unparalleled achievements of ancient China.

NEW!

7X10 P/B, 288 pp., Full-color, Illus. \$29.95

GLIMPSES OF OTHER REALITIES—VOL. 1 *Linda Moulton Howe*—Discover the truth behind the US Government's cover-up of paranormal activity. Emmy award winning journalist Linda Moulton Howe presents evidence that a non-human intelligence is interacting with earth, including information about recovered crash debris and the transfer of human souls from body to body—evidence of a mystery involving the entire human race.

365 pp., 8.5 x 11, PB many b&w & color photos & images \$45.00

GLIMPSES OF OTHER REALITIES—VOL. II: High Strangeness

PB, 477 pgs., b&w photos illus., 11" x 8.5" \$27.95

HIDDEN HISTORY OF THE HUMAN RACE *Michael A. Cremo & Richard L. Thompson*—Graham Hancock, calls *Hidden History Of The Human Race* "One of the landmark intellectual achievements of the late twentieth century." Condensed from *Forbidden Archeology*, this edition exposes a major scientific cover-up showing that people like ourselves were here millennia ago.

Paperback, 228 pgs. black & white illus., 6 x 9 \$15.95

HIMMLER'S CRUSADE: Nazi Expedition to Find the Origins of the Aryan Race

Christopher Hale—In 1938, virtually on the eve of war, a Nazi expedition set out through British India on a mission sponsored by Himmler himself. As the Indiana Jones films showed, Nazis, new age mumbo-jumbo and exotic locations are a formula that works. In 1935 Heinrich Himmler founded an organization called Ancestral Heritage to uncover the hidden past of an imaginary Aryan race he and his Fuhrer regarded as the noblest and most vital force in human history. One of the scientific missions Himmler sponsored was a multitasked expedition to Tibet. The Nazi scientists sought to show that the Tibetan theocracy had destroyed the vitality of an earlier warrior culture, as Christianity had supposedly had an emasculating effect on the ancient pagan Germans.

6X9 H/B, 422 pp., Illus., Photos \$18.95

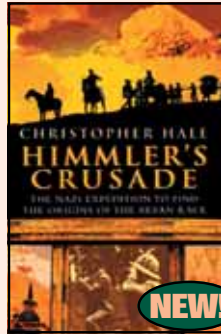

NEW!

HITLER'S SUPPRESSED AND STILL-SECRET WEAPONS, SCIENCE AND TECHNOLOGY

Henry Stevens—Now we know what spooked the Allies in the closing months of the war and why they were in such a panic to win quickly. The Allies assembled intelligence reports of supermetals, electric guns, and ray weapons able to stop the engines of Allied aircraft in addition to their worst fears of x-ray and laser weaponry. Then there were the bombs. Contained in this book are reports of structured bombs of nipolit, N-stoff bombs, cold bombs, oxygen bombs which destroyed all life, atomic bombs and rumors of the mysterious molecular bomb. The true history of the fuel-air bomb is revealed by our own military. There is even a probability that the SS black alchemists of the Third Reich were experimenting with red mercury bomb technology. This book documents very large mystery rockets under development in Germany, far beyond the V-2.

6X9 P/B, 335 pp., Illus. \$19.95

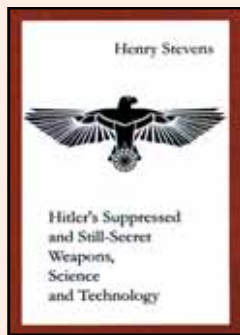

HOW TO SURVIVE 2012: Tactics & Survival Places for the Coming Pole Shift *Patrick Geryl (Orion Prophecy and The World Cataclysm in 2012)*—In his previous books, Geryl presented in great detail the scenario set to take place in the year 2012, a scenario of complete and utter destruction which has occurred in Earth's past and will occur again. Due to a recurring pattern of activity in the sun's magnetic fields, the magnetic poles of the sun reverse from time to time. This, in turn, causes the release of massive solar flares that lash out into the solar system. These cause havoc with the Earth's magnetic field, resulting in the reversal of the Earth's magnetic poles, hence a reversal of its very rotation. He explains in detail the myriad problems survivors will encounter and the precautions that need to be taken to overcome them. It is his hope that with this information in hand, enough people will live on to re-establish civilization and continue human life on Earth.

6X9 P/B, 213 pp., B&W photos & illus. \$16.95

HUMAN DEVOLUTION *Michael A. Cremo*—Where DID we come from? Drawing upon a wealth of research into archeology, genetics, reincarnation memories, out-of-body experiences, parapsychology, cross cultural cosmology, and the search for extraterrestrial intelligence, Cremo provides a refreshing perspective on human origins according to the ancient philosophy of India.

6x9 H/B, 584 pp. \$35.00

INTO THE LIGHT: Real Life Stories About Angelic Visits, Visions of the Afterlife, and Other Pre-Death Experiences

John Lerma, M.D.—Despite our advancements in science and medicine, death remains one of human civilization's most glorious mysteries. A handful of doctors have written books on phenomena such as near-death experiences, but research and data is scarce on pre-death experiences. Because of this lack of information, Dr. John Lerma has devoted his career to compiling anecdotal and scientific research on pre-death hallucinations from the countless terminally-ill patients he lovingly cares for as a doctor and director at The Medical Center of Houston, Texas. Now, in this groundbreaking book, Dr. Lerma shares his valuable research and guidance in 16 inspirational stories of children and adults confronting their deaths through the comforting visions of divine beings.

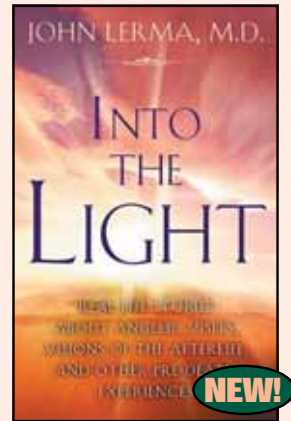

NEW!

6X9 P/B, 240 pp. \$14.99

JOURNEYS TO THE MYTHICAL PAST *Zecharia Sitchin*—In this sequel to *The Earth Chronicles Expedition*, the author tells his own story of an indefatigable dedication to finding the truth that almost cost him his life—accidentally or otherwise—when uncovering secrets of the Giza pyramids and Sphinx. Exposing hidden artifacts that contradict establishment assumptions dedicated to preserving the status quo or that baffle scientists when forced to show them, Sitchin's firsthand accounts of his explorations take the reader into the inner workings of the Vatican, the enigma of a futuristic computer from millennia ago, and the secret handiwork of a Divine Architect at Stonehenge, at Malta, and at a site in the Americas. Looking deep into antiquity, he offers astounding evidence that links the Nazca lines and a baffling adjoining site to the Departure from Earth of the Anunnaki, the ancient gods who, he believes, vowed to return.

6X9 H/B, 288 pp., two 16-pg. color inserts consisting of 48 color plates and 130 B&W illus. \$24.00

10% Discount on orders of over \$100 (See page 81)

the ATLANTIS RISING Catalog



NEW!

MAN-MADE UFOS: War World II's Secret Legacy (REVISED EDITION) David Hatcher Childress & Renato Vesco—This is a classic on suppressed technology and the early flying saucer technology of Nazi Germany and the genesis of man-made UFOs. While the government wants you to think that aliens are crashing their ships and buzzing military bases, this

book presents the overwhelming evidence that most nuts and bolts UFOs are made on Earth and piloted by Earthlings—it takes you from the work of captured German scientists to escaped battalions of Germans, secret communities in South America and Antarctica, to today's state-of-the-art "Dreamland" flying machines. It blows the lid off the "government UFO conspiracy" and explains with detailed diagrams the technology involved. Examined in detail are secret underground airfields and factories; German secret weapons; the origin of NASA; gyroscopic stabilizers and engines; the secret Marconi aircraft factory in South America; and more.

6X9 P/B, 524 pp., Illus. \$22.95

MYSTERIES OF THE BRIDECHAMBER: Initiation of Jesus and the Temple of Solomon

Victoria LePage—As a fearless social reformer, Jesus wanted to restore the authority of the feminine principle, including asserting the equality of man and woman in the social contract of marriage. He reinstated in his own life the tradition of sacred consortship—a rite known to early Church fathers as the bridechamber sacrament, whereby the marriage of the masculine and feminine energies was effected. This rite, the author suggests, was the primary focus of Jesus' teachings, the very heart of his exhortations to love thy neighbor, and the source of his healing power. This book explains how, as a master adept of the Temple of Solomon, Jesus derived these teachings directly from ancient Judaic mystery traditions, revealing both a life story for Jesus that differs markedly from the version the Church has offered, as well as a spiritual practice based on a mystical wisdom tradition of self-initiation and transformation.

6X9 P/B, 448 pp., 14 B&W Illus. \$19.95



NEW!

MYSTERY OF 2012: Predictions, Prophecies and Possibilities

Gregg Braden, Peter Russell, Daniel Pinchbeck—What Will Happen in 2012? Will there be an age of awakening, a new step in human evolution, or even an end to the world we know? For years, archaeologists have known the Mayan calendar predicts this date

as the end of an era on Earth. Today more and more researchers, spiritual explorers, and even scientists are witnessing signs that 2012 will mark a critical shift in the history of our planet. Now, the leading authorities on the 2012 phenomenon present their insights about this enigmatic date. Featuring essays from 25 renowned experts on the question of 2012, this invaluable anthology examines the mystery from every angle—spiritual, economic, ecological, and scientific—and you can decide for yourself whether 2012 will end with a whimper or a bang.

6X9 P/B, 417 pp. \$22.95



NEW!

MYSTERY OF THE OLMECS David Hatcher Childress—The Olmecs were not acknowledged to have existed until an international archaeological meeting in Mexico City in 1942. Now they are slowly being recognized as the mother culture of Mesoamerica having developed metallurgy, writing and the calendar long before the Maya. The statuary left behind by these enigmatic people very clearly depict features that seem to indicate residents of the Land of Olman came from Africa, Asia and Europe. Was the narrow isthmus of southern Mexico an important part of a trade route that spanned both the Atlantic and Pacific Oceans? Examine the evidence in this fascinating book by one of the most interesting historians around. You might learn more than you wanted to know about these strange people.

6X9 P/B, Color Section, Illus. \$20.00

NAZIS AND THE OCCULT: Dark Forces Unleashed by the Third Reich

Paul Roland—For the first time, this secret history of the Third Reich reveals the full extent of Hitler's obsession with the occult and the Nazis' fascination with symbols of arcane power such as The Ark of the Covenant and the Spear of Destiny. It explains how an ill-educated, psychologically unbalanced nonentity mesmerized an entire nation; why the German people venerated their Fuhrer as a god; and how he exercised his power over them so that they would willingly follow him to the abyss of self-destruction. Tons of illustrations.

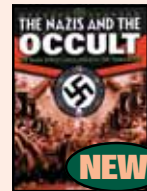

NEW!

9X12 P/B, 208 pp. \$19.95

NEPHILIM AND THE PYRAMID OF THE APOCALYPSE Patrick Heron—Heron examines ancient texts from Genesis to the Book of Enoch to Revelations to once and for all establish the true identity of this mysterious, lost race of giant beings. Are they angels? Genetic monsters? Are they characters of fable and myth? Are they still among us? Within these pages the answers are finally revealed. The identity of the Nephilim firmly in hand, Heron takes his research deeper, using science and an examination of age-old prophecies to discover the true meaning of the pyramids.

6X9 P/B, 241 pp., Illus. \$13.95

PARAPSYCHOLOGY AND THE SKEPTICS

Chris Carter—Today, in the world of science, nothing is more controversial than parapsychology, and this battle has been raging for centuries. It has been carried on in scientific academies, courtrooms, academic journals, newspapers and radio stations. The story of parapsychology's struggle for legitimacy is an epic tale, containing victories, sudden reversals, intrigue, scandals, heated arguments, wild accusations, ruined reputations, and some of the most bizarre characters that have ever walked the earth. Are we capable, at long last, of rationally resolving the issue? This book is a critical examination of the arguments of the skeptics. Starting with the history of the controversy, dating back to the scientific revolution of the 17th century, this book reappraises the controversy in light of 20th and 21st century scientific and philosophic developments. Highly readable and immensely entertaining, the reader is provided with some striking anecdotal case studies.

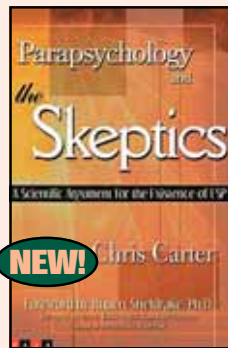

NEW!

6X9 P/B, 260 pp. \$18.95

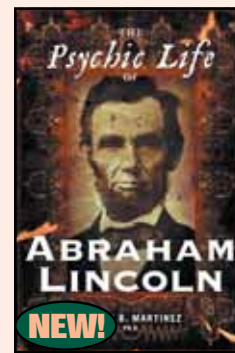

NEW!

PSYCHIC LIFE OF ABRAHAM LINCOLN

Susan B. Martinez, Ph.D.—In dreams, Lincoln foresaw his sudden death. He consulted oracles, and at age 22 was told by a seer that he would become President of the United States. His rise to power coincided with the Great Age of Spiritualism and, as a Mystical Unionist, he felt he was controlled by

"some other power." Aided by the deathbed memoir of his favorite medium, Lincoln's remarkable psychic experiences come to life with communications from beyond, ESP, true and false prophecies, as well as thumbnail sketches of the most influential spiritualists in Lincoln's orbit. Surveying clairvoyant incidents in Lincoln's life from cradle to grave, the book also examines the Emancipation Proclamation and the unseen powers that moved pen to hand for its historic signing into law.

6X9 H/B, 288 pp., 15 Photos/Illus. \$24.95

SACRED SYMBOLS OF THE DOGON: The Key to Advanced Science in the Ancient Egyptian Hieroglyphs

Laird Scranton (Science of the Dogon); Foreword by John Anthony West—In "The Science of the Dogon," Scranton demonstrated that the cosmological structure described in the myths and drawings of the Dogon runs parallel to modern science. In this book, he points to the close resemblance between the keywords and component elements of Dogon cosmology and those of ancient Egypt and the implication that ancient cosmology may also be about actual science. By substituting Dogon cosmological drawings for equivalent glyph-shapes in Egyptian words, a new way of reading and interpreting the Egyptian hieroglyphs emerges. He shows how each hieroglyph constitutes an entire concept, and that their meanings are scientific in nature. He reveals references within the ancient Egyptian language that define the full range of scientific components of matter—from massless waves to the completed atom, even suggesting direct correlations to a fully realized unified field theory.

6X9 P/B, 240 pp., Illus. \$16.95

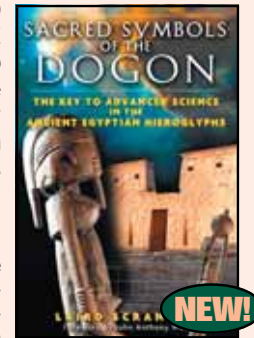

NEW!

SECRET HISTORY OF CONSCIOUSNESS

Gary Lachman (Foreword by Colin Wilson)—For the last four centuries, science has tried to account for everything in terms of atoms and molecules and the physical laws they adhere to. Recently, this effort was extended to try to include the inner world of human beings. Lachman argues that this view of consciousness is misguided and unfounded. He points to another approach to the study and exploration of consciousness that erupted into public awareness in the late 1800s, pioneered by people like H.P. Blavatsky. In this book consciousness is seen not as a result of neurons and molecules, but as responsible for them; meaning is not imported from the outer world, but rather creates it. In this view, consciousness is a living, evolving presence whose development can be traced through different historical periods, and which evolves along a path to a broader, more expansive state.

6X9 P/B \$29.95

SECRETS OF THE ICA STONES AND NAZCA LINES *Dennis Swift*—Creationist Dennis Swift attempts to demonstrate the amazing proof that South American Indians were eyewitnesses of dinosaurs, proving that men and dinosaurs lived together and not 30,000,000 years apart. He also gives us high technology in ancient civilizations; attempts to unravel the mystery of the Nazca lines; and gives us "scientific proofs" of the authenticity of the Ica stones.

6X9 P/B, 144 pp., illus. \$13.95

SECRET SOCIETIES- GARDINER'S FORBIDDEN KNOWLEDGE: Freemasons, Templars, Illuminati, Nazis and Serpent Cults *Philip Gardiner*—Once again Gardiner finds himself on a journey across the world to uncover the ancient secrets of the world's most powerful men. In one dramatic episode he finds himself driven out of Berlin in a black Mercedes by a secret organization that was believed to have disappeared after the Second World War and he eventually arrives in a modern Nazi watering hole. Gardiner, however, survives and brings us the secrets of the Order held sacred for so long. Nobody in the genre involves themselves in the tale in the same way that Gardiner does, and here he shows that the search for ultimate truth can often be a terrifying one.

6X9 P/B, 256 pp. approx., photos/illus. \$14.95

SOLOMON'S POWER BROKERS: Secrets of Freemasonry, the Church, and the Illuminati *Christopher Knight and Alan Butler (Civilization One)*—In this eye-opening account, two seasoned researchers show that today's Freemasons are the spiritual descendants of an ancient priesthood that was forced to act in secrecy. They predicted the birth of the coming Messiah, and Jesus Christ was part of their mission. Soon after the Crucifixion they were nearly wiped out by a program of mass genocide conducted by the Romans. Later, in feudal Europe, they grew to a position of unparalleled power before being branded as heretics and forced underground. But they could not be stopped, and they continued to work in subtle, sometimes subversive, always anonymous, ways to pursue their objective—a new world order that puts God above, and yet out of, human affairs.

6X9 H/B, 306 pp., 8-pg. color insert \$24.95

SPIRITUAL TECHNOLOGY OF ANCIENT EGYPT: Sacred Science and the Mystery of Consciousness *Edward F. Malkowski*—Since the dawn of the Age of Science, humankind has been engaged in a methodical quest to understand the cosmos. With the development of quantum mechanics, consciousness is now being considered as much a fundamental part of reality as the three dimensions with which we are so familiar. Although this direction in scientific

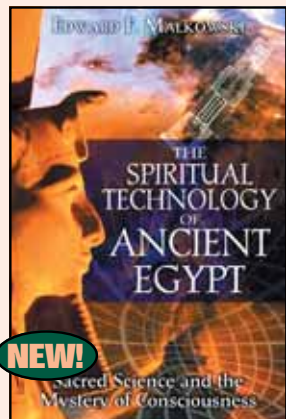

thought is seen as a new approach, the secret wisdom of the ancients presented just such a view thousands of years ago. Malkowski shows that the ancient Egyptians' worldview was not based on superstition or the invention of myth, but that it was the result of direct observation using critical faculties attuned to the quantum manifestation of the universe. In the philosophical tradition of Schwaller de Lubicz, this book investigates the technical and religious legacy of ancient Egypt to reveal its congruence with today's "New Science."

6X9 P/B, 448 pp., 35 B&W Illus. \$22.95



STAR OF THE MAGI: The Mystery That Heralded the Coming of Christ

Courtney Roberts—Why would the authors (and editors) of the Christian gospels choose Zoroastrian Magi and astrology to herald the coming of Jesus Christ? Did the Magi have some special significance then that we have since lost? After all, the New Testament narrative opens with them. So who were the Magi, and did their astrological beliefs really lead them to Jesus? Now, for the first time, this author with a solid background in the history of astrology in ancient religion examines The Star. The result is a breathtaking blend of history, religious studies, astronomy, and astrology that tells the whole story as it has never been told before.

6X9 P/B, 224 pp. \$14.95

TOLTEC DREAMING: Don Juan's Teachings on the Energy Body

Ken Eagle Feather—This book explores the many aspects and levels of the dream-state, distinguishing ordinary dreaming from "dreaming awake," a condition of heightened awareness through which the active dreamer ascends to the Dream of Transcendence. The author presents the history of dreaming's place within the Toltec tradition and provides a practical how-to manual for achieving and maximizing dreaming potential. The Toltec Way superimposes on the waking world the subtle physics of the dream world in order to create a conscious dreaming body, often referred to as an "out-of-body experience," that can allow anyone to use dreaming as a vehicle to higher consciousness.

6X9 P/B, 272 pp., 9 B&W Illus. \$16.00

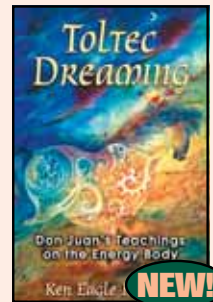

TRIUMPH OF THE SEA GODS: The War Against the Goddess Hidden in Homer's Tales *Steven Sora (Lost Treasure of the Knights Templar)*—Sora compellingly argues that Homer's tales do not describe adventures in the Mediterranean, but are adaptations of Celtic myths that chronicle an Atlantic coastal war which took place off the Iberian Peninsula long before. It was a war between the pro-goddess Celtic culture that presided over what is now Portugal and the patriarchal culture of the sea-faring Atlanteans. The invasion of the Atlantean sea peoples brought destruction to the entire region stretching from Western Europe's Atlantic border to Egypt, Syria, and Turkey. The goddess became demonized as seen in myths such as Pandora's Box in which woman was seen as the source of evil, not the origin of life, and Homer's tale of the epic Greek and Trojan war, which was triggered by the abduction of a woman.

6X9 P/B, 288 pp. \$18.95

TURNING THE SOLOMON KEY: George Washington, the Bright Morning Star, and the Secrets of Masonic Astrology *Robert Lomas (Turning the Hiram Key)*—Using Masonic rituals and Washington's own diaries, Lomas uncovers the symbolic reasoning behind the siting of the White House and the Capitol and in the process disposes of many anti-Masonic urban myths. This exciting and authoritative detective story also investigates the sources of creative behavior—to reveal an unsuspected, until now, secret science of Masonic astrology which underpinned Washington's actions.

6X9 H/B, 335 pp., B&W photos & illus. \$27.95

VORTEX THEORY *Russell Moon*—Complete paper offering the author's challenge to Einstein. Includes "End of the Concept of Time." Moon's work was presented and praised in October at a major Russian Scientific Conference. It is currently being taught in schools in China.

8-3/4"x11", PB, 184 pp. Color Illus. \$29.95



WEATHER WARFARE

Jerry E. Smith—Floods, Droughts, Tsunamis, Hurricanes & Volcanic Eruptions—Weapons of the Future—Or Today? Weather modification in the form of cloud seeding to increase snow packs in the Sierras or suppress hail over Kansas is now an everyday affair. Hundreds of environmental and weather modifying technologies have been patented in the United States alone—and hundreds more are being developed in civilian, academic, military and quasi-military laboratories around the world at this moment! This book lays bare the grim facts of who is doing it and why.

6X9 P/B, 382 pp., B&W photos & drawings \$18.95

WHO BUILT THE MOON? *Christopher Knight (The Hiram Key) and Alan Butler (Civilization One)*—Could it be that the moon is artificial? Could it even be hollow? A seeming impossibility for a natural planetary object. But keep an open mind and read the compelling arguments based on scientific evidence and irrefutable logic—arguments that will completely change the way we think of our world; such as: Why does the moon have little or no heavy metals, and no core? Why did the Apollo lunar teams at NASA report on several occasions that the moon rings like a bell when struck? Why is it that the moon revolves at exactly one hundredth of the speed that Earth turns on its axis? And why is the moon exactly 400 times smaller than the sun and precisely 400 times closer to Earth? And why does an ancient system of geometry and measurement used in the Stone Age work perfectly on the Moon? If our moon did not exist, neither would we.

6X9 P/B, 262 pp., 8-pg. color insert \$14.95

THE WORD MADE MANIFEST THROUGH SACRED GEOMETRY *Robert Thomas (Chapter 1 contributed by Jeanne Manning, author of "The Coming Energy Revolution")*—This is the story of David Hamel of Ontario and what he was taught by visitors from the cosmos. This book provides: the possibilities of advanced spacecraft the meaning of "Sacred Geometry" how the musical scale, based on phi, connects metaphysics and science how Stonehenge and the Great Pyramid and the Egyptian Book of the Dead tie in with the Christian Bible and new or ancient energy technology. After visiting Mr. Hamel, the author used mathematics to discover underlying principles in the Torah and Christian Bible which relate to the Hamel spaceship. Hamel says that Stonehenge was a jig on which to build a flying saucer. Included with this book are three actual blueprints of the Hamel device.

10x13 P/B, 370 pp., numerous B&W drawings, some color \$37.00

ZERO POINT ENERGY:

Fuel of the Future *Tom Valone*—This book demonstrates the exciting promise that zero point energy, which supports every atom and molecule, will soon be used directly to power a car, house, or spaceship. With a clear, simple-to-understand style, a former community college teacher provides the only book with the history and science of zero point energy that emphasizes its usage. Here is the only uninterrupted fuel supply for the near future that will be here sooner than you think. Business entrepreneur? You need to learn about this before your competition does.

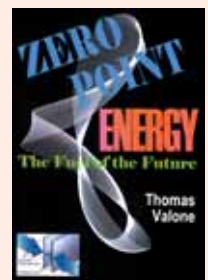

6X9, 228 pp. \$22.00

ATLANTIS RISING DVDs

CLASH OF THE GENIUSES: INVENTING THE IMPOSSIBLE

Here, at last, is the story of a handful of inventors battling to save the world from industrial giants, like Ford, Morgan, Edison and their ilk. From Nikola Tesla to T. Henry Moray, from John Keely to Pons and Fleischman, the struggle to break through with world-saving technologies has gone on for generations, but now a new breed of inventors threatens to succeed where others have failed. Here is the story and the commentary of the geniuses behind many of today's amazing discoveries in free energy, antigravity, rejuvenation, and much more.

One-Hour VHS \$19.95 DVD \$24.95

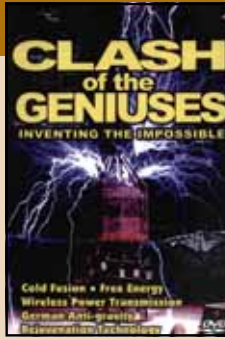

ENGLISH SACRED SITES: THE ATLANTIS CONNECTION

Powerful evidence linking Stonehenge, Avebury, Glastonbury and many other English locations with an advanced ancient order now lost to history. Written and

narrated by Atlantis Rising editor Doug Kenyon, the video is based primarily upon the discoveries of Cambridge-trained scholar and author John Michell. The program demonstrates how a mysterious network of perfectly straight tracks, laid out for hundreds of miles across the English landscape, proves the great advancement of pre-historic science.

Forty minutes VHS \$19.95 DVD \$24.95

TECHNOLOGIES OF THE GODS

Overwhelming evidence of the existence of high technology in prehistoric times, this video shatters the orthodox scenario for the dawn of civilization on Earth. Now assembled in a devastating one-hour documentary, hosted by Atlantis Rising Editor and Publisher J. Douglas Kenyon,

are the comments and evidence of breakthrough researchers such as John Anthony West, Robert Bauval, Richard Noone, Colin Wilson, John Michell, Patrick Flanagan, Christopher Dunn, Zecharia Sitchin, David Hatcher Childress, Edgar Evans Cayce and others.

One-Hour VHS \$19.95 DVD \$24.95

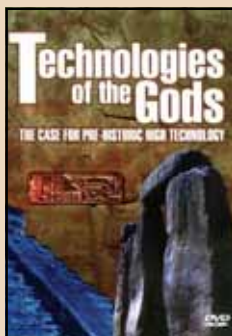

the ATLANTIS RISING Catalog

10% Discount on orders of over \$100 (See page 81)

HARD-TO-FIND VIDEO, DVD, etc.

2012 THE ODYSSEY: Is It the End of Time? *Jay Weidner and Sharron Rose*—The Mayan Calendar is ending on December 21, 2012. What will happen to us between now and then? Are there other prophecies that also predict the closing of this world age and the start of a new beginning? In this feature documentary Sharron Rose travels across the United States speaking to the many experts on this fast approaching prophecy.

99 min. \$19.95

ACTIVATING YOUR POWER TO CREATE *Dale Pond*—We've all heard that we are powerful creators. Countless books have been written on this topic which we've all studied to little avail. Maybe, just maybe, the process is so simple we've been overlooking it. Recently, Pond has discovered a new approach that works. It is simple, direct, immediate and doable. You can learn it firsthand.

1 1/2 hr. DVD ONLY \$24.95

ANCIENT POWER PLANTS AND ADVANCED TECHNOLOGY

(from the 1999 Egypt In The New Millennium conference) *Christopher Dunn*—Explore how the pyramids were really built, and how they were used.

DVD 240 min. \$39.95

BIOLOGY OF BELIEF

Dr. Bruce Lipton—Broadly reviews the molecular mechanisms by which environmental awareness interfaces genetic regulation and guides organismal evolution. The quantum physics behind these mechanisms provide insight into the communication channels that link the mind-body duality. This knowledge can be employed to actively redefine our physical and emotional well-being.

120 min. DVD only \$39.95

CONSCIOUSNESS: 20 Scientists, 9 Hours

Brace yourself. All the questions you ever had about your identity, your mind, your dreams, your place in the universe, and your role in eternity are about to be addressed in a head-on, take-no-prisoners, no-holds-barred fashion by a group of fearless professors who dare

plunge where science itself is only just beginning to venture—into the deepest realms of interior human existence—into the soul. There is great excitement afoot and you are about to become part of it. This total immersion into the world's latest theories on consciousness includes in-depth discussions with twenty scientists on topics as diverse as quantum biophysics, nano-neuroscience, philosophy, meditation, metaphysics, dreaming, causation, and the paranormal, all of which are converging into the greatest exploration of all time, to understand just who, or what, we are.

9 Hours 5-DVD Boxed Set \$39.95

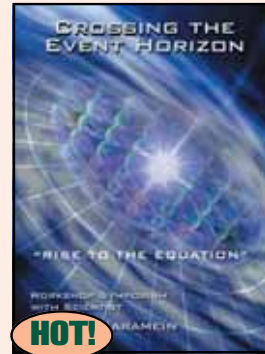

CROSSING THE EVENT HORIZON

Nassim Hameiri—In this extraordinary DVD presentation, filmed live, Nassim will take you on a fantastic journey through the history of the evolution of humanity, pointing out inconsistencies in our concepts of physics and the rectification necessary to

produce a true unification process—one that unifies the four forces of nature, biological evolution, and even the occurrence of consciousness. Astonishingly, Nassim also demonstrates that this new all-encompassing theory seems to have parallels with ancient codes left in documents and colossal monuments around the world. As the tale weaves between the sciences of biology, chemistry and physics, and then to the wisdom and codes of the ancients, an exciting picture develops—one that may prove to be the most important scientific, philosophic and technological discovery of our time.

DVD - Set of 4 \$65.65

CROSS OF THOTH: The Hidden Truth to Mankind's Most Revered Symbol

Chrichton E. M. Miller (The Golden Thread of Time)—Lost in the thread of time, an incredible discovery has emerged from the dust of ages—deep within the Great Pyramid is a secret that has remained hidden for over 4000 years—an ancient instrument designed to unlock mysteries that have baffled mankind for generations. The seal is broken. Within this film you will find knowledge of the greatest magicians that ever walked our planet. Says Philip Gardiner, who directed this film, "Chrichton Miller is a man on a mission. His mission is, in my humble opinion, far more important than the Victorian search for the source of the Nile or the 60's race for space. It is more extravagant than the discovery of Tutankhamun's tomb and of more archaeological, scientific and historical importance than just about anything else you care to mention."

DVD - 65 min. \$24.95

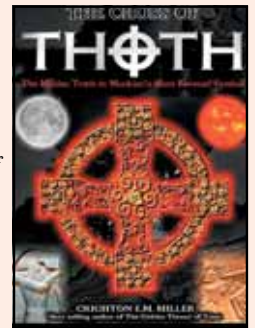

FABRIC OF TIME: Are the Secrets of the Universe Hidden in an Ancient Cloth?

Grizzly Adams Productions—Were the Carbon-14 tests of 1988 the final word on the authenticity of the Shroud of Turin? Absolutely not, according to this production. There is new, stunning information revealing more depth to

the Shroud than ever considered. Holographic information is encoded in the Shroud, which some of the research scientists have called a "blueprint of the universe, maybe an opening to a new science!"

DVD - 120 min., 3D Glasses included \$19.95

FASTWALKERS:
They Are Here—UFO
& Alien Disclosure,
the Government
Coverup Finally
Exposed

Presented by *Safespace News Agency*—Discover the truth about extraterrestrial contact. Here is astounding revelations by the world's foremost authorities, including: Dr. Steven M. Greer, Steve Bassett, Jim Marrs, Robert O. Dean, Dr. Michael Salla, Stanton T. Friedman, Alfred L. Webre, John Greenwald Jr., Dr. Len Horowitz, Dr. Richard Boylan, Jaime Maussan, Paola Harris, Jerry Pippin, Dr. Bruce Maccabee, A. J. Gevaerd, Sean David Morton, Graham E. Bethune, Col. Wendelle C. Stevens, Monsignor Corrado Balducci, James W. Deardorff, Ph.D., Robert M. Wood PhD, Charles Hall, Richard Dolan, Steven Jones, Rob Simone, Don Ware, Richard Giordano, James Courant, Dolores Cannon, Maurice Osborn, David Coote, Stoyan Cheresharov, Daniel Munioz, Lisa Davis, Bruce Jessop, Robert Miles, Alan G. Toleman, Jutta Savill. Hosted by Erika Jessop. Never before has there been such a disclosure of the web of lies and disinformation that the governments of the world do not want you to know!



98 min. DVD \$19.95

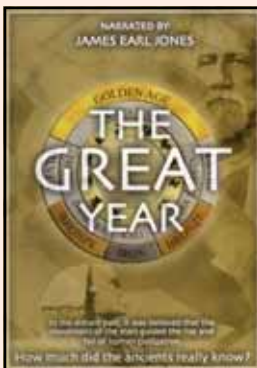

THE GREAT YEAR
Narrated by James Earl Jones—The Great Year. Investigates commonalities in ancient beliefs and looks back into time for answers to questions that still loom over science today. How far back do humankind's roots really go? What did the ancients know about the stars and their movements and what

can we learn from them? How was the Precession of the Equinox used to mark the rise and fall of these great ages by the ancients? The Great Year examines this theory and finds that perhaps these ancients were really onto something!

46 min. DVD \$19.95

LETTERS FROM EGYPT MCF Productions—This production allows you to tour Egypt with top researchers in the field: David Childress Christopher Dunn Stephen Mehler Abd'El Hakim Awyam, and Mark & Andrea Pinkham, and the producer, Mark Flett.

10 hrs. (Individual DVDs run an average of 1-1/2 hrs. each) 6-DVD Set \$120.00 or \$25.00 each

LIFE ON MARS? New Scientific Evidence

The press conference with Tom Van Flandern, former Chief Astronomer for the U. S. Naval Observatory and Brian O'Leary, former Apollo Astronaut trained for America's first manned mission to Mars. In this historic press conference, scientists announce the discovery of startling artifacts found among the 65,000 recently released NASA/JPL photos by Mars Global Surveyor. They believe these artificial structures are proof that Mars was once inhabited by an intelligent civilization."



Approx. 1 hr. DVD \$24.95

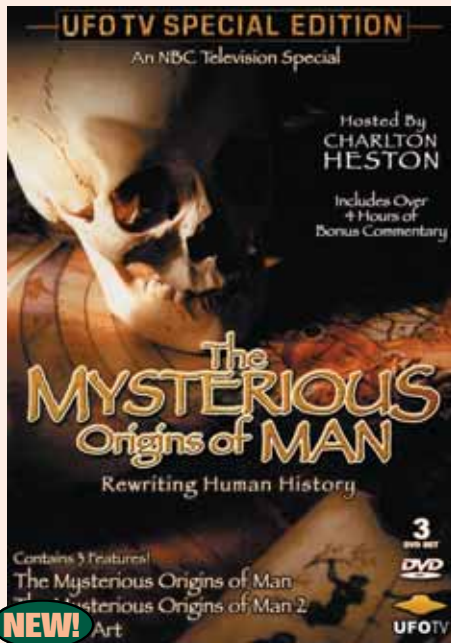

MYSTERIOUS ORIGINS OF MAN - Special Expanded Edition

The creators of the Emmy-Award-Winning Mystery of the Sphinx present a revolutionary film that examines one of our greatest mysteries—Man's origins. Hosted by Charlton Heston, this film challenges what we are being taught about human evolution and the rise of early civilization. A new breed of scientific investigators present startling evidence that the academic community has quietly ignored. • Did humans evolve from the ape? • Did humans live at the time of the dinosaur? • Could the "Lost Continent of Atlantis" be buried under two miles of ice? If this evidence is allowed to speak for itself, human history on this planet may be radically different than what is accepted today. Includes a fascinating series of spellbinding interviews with researchers, scientists, and the best known, most credible authorities in the world today. There are three feature length programs in this set: "The Mysterious Origins of Man"; "Mysterious Origins of Man - Part 2"; and "Jurassic Art". Features over 4 hours of uncut bonus interviews with: Graham Hancock, Robert Bauval, Michael Cremo, Dr. Richard Thompson, Richard Milton, and David Childress.

3 DVDs - 343 min. \$49.95

PRIVILEGED PLANET

Illustra Media—Many scientists and philosophers have claimed that Earth is an ordinary speck of dust adrift, without purpose or significance, in a vast cosmic sea. Yet current astronomical evidence seems to suggest just the opposite. Through stunning computer animation, interviews with leading scientists, and spectacular images of Earth and the cosmos, this DVD explores a startling connection between our capacity to survive and our ability to observe and understand the universe. Is this correlation merely a coincidence? Or does it point to a deeper truth about purpose and intelligent design within the cosmos?



60 min. \$19.95



QUANTUM MIND OF GOD: Our Questions are About to Be Answered
Philip Gardiner—What is the meaning of existence? Is there a Grand Architect? Is there an ultimate truth searched for by countless generations and lost in the mists of time? Today we have a new science, a new terminology, to explain and expound upon the biggest beliefs and religious systems. It has become apparent that the truth and understanding of our inner selves is, in the end, our ultimate quest. The void between belief and reality is indicative of the troubled planet we live on. As we all approach a dynamic future, the answers will emerge—although they might not be what we're expecting.

DVD - 65 min. \$24.95

REAL BLOODLINE: The Sacred Teachings of Tim Wallace-Murphy —The Truth Behind the Da Vinci Code

Reality Films—Tim Wallace-Murphy is an international, best-selling author known throughout the world for his deep knowledge of Roslyn, the Knights Templar, Sacred Geometry and Rex Deus—the real bloodline of Jesus Christ—and the sacred continuation of esoteric and gnostic knowledge. His best-selling books include *Guardians of the Secret of the Holy Grail* and *Cracking the Symbol Code*. He is a doctor of medicine and psychology and has spent decades researching the ancient traces of the wisdom tradition. In this DVD, he talks about the real bloodline of Jesus Christ and Mary Magdalene, the Secret Brotherhoods, the Knights Templar, the Cathars, the Sufi's and reveals the spiritual truths held sacred by these groups for centuries. Interviewed exclusively for Reality Films by best-selling author Philip Gardiner, we are given a wonderful and frank insight into the true wisdom of the ages.

DVD - 65 min. \$24.95

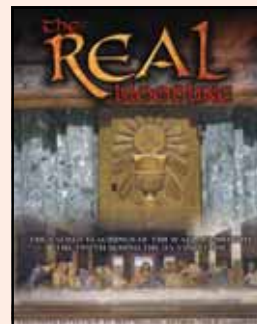

REMEMBERING ATLANTIS with Doug Kenyon

Atlantis Rising publisher Doug Kenyon talks about planetary amnesia. From "Signs of Destiny II: Crop Circles and Earth Mysteries Conference" at Tempe, AZ in November of 2003.

90 min. VHS and DVD \$24.95



RIDDLES IN STONE: The Secret Architecture of Washington D.C.—Secret Mysteries of America's Beginnings—Vol. II (Vol. I was *The New Atlantis Antiquities Research Films*)—This DVD continues to explore the fascinating history behind the origins and focus of the world's most powerful nation—America. Why was this nation founded? How was the precise location of Washington D.C. determined? What is the meaning of the seemingly countless occult images in our nation's capitol? Volume II zeroes in on the Masonic and Rosicrucian influence on our Founding Fathers.

DVD - 170 min. \$29.95

SEARCH FOR THE REAL MT. SINAI

Two explorers take an incredible expedition into the blistering Arabian Desert and turn up what some scholars believe to be one of the greatest discoveries in history—the real Mt. Sinai, the holy mountain on which Moses received the Ten Commandments. This program chronicles their amazing adventure, how they crawled into forbidden military installations and used night vision goggles to avoid being detected as they pursued remnants still remaining at the site. They found remarkable evidence which they believe confirms the Bible as historically accurate.

50 min. DVD \$19.95

SCIENCE OF SOUL: The End-Time Solar Cycle of Chaos in 2012 A.D.

John Jay Harper—This production is filled to the brim with facts that offer viewers the 'lost key' to the secrets of the ages that was only briefly introduced in the DVDs, *What the Bleep Do We Know?* and *The Secret*. Specifically, our deepest relationship to the 'magic of magnetism' and sacred-site structures on Earth with the solar-flare cycles of our sun. In no-uncertain terms, says Harper, the Egyptians and Mayans did reveal to us in art and story the life force energy that he says is about to turn our world upside down and inside out.

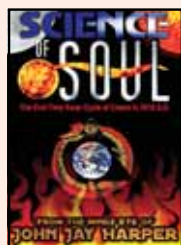

65 min. \$24.95

STARWALKERS and the Dimension of the Blessed *William Henry*—Behind all myths there is one message, a timeless truth that mystic traditions point to—our Earthly lives are a preparation for life as Starwalkers, advanced, inter-dimensional beings, who travel the Dimension of the Blessed. In this comprehensive study, Henry reconstructs the ancient beliefs in this Dimension from clues taken from Egypt, Sumeria, Greece and America. When pieced together, these myths create an adventure to a realm of incredible possibility. A few of the enigmas this book explores includes: the Egyptian belief that inter-dimensional beings of light created humanity; how the study of other dimensions can affect our biology and will change our lives in the near future. In November 2007 the Large Hadron Collider, a 17-mile-long particle accelerator, will start up. Theoretical physicists believe they will find proof of the existence of other dimensions, a discovery that will forever change our understanding of our world and ourselves.

180 min. DVD 2-disk set \$24.95

UNLOCKING THE MYSTERY OF LIFE: The Scientific Case for Intelligent Design

Illustra Media—This is the story of contemporary scientists who are advancing a powerful, but controversial, idea—the theory of "intelligent design." It is a theory based upon compelling biochemical evidence. Through state-of-the-art computer animation, you're transported into the interior of the living cell to explore systems and machines that bear the unmistakable hallmarks of design. Discover the intricacy of a microscopic bacterial rotary motor, which spins at 100,000 rpm. Within the cell nucleus, explore the wonder of DNA, a threadlike molecule that stores instructions to build the essential components of every living organism. It is part of a biological information processing system more complex and more powerful than any computer network. This remarkable documentary examines the scientific case for intelligent design—an idea with the power to revolutionize our understanding of life—and to unlock the mystery of its origin.

67 min. DVD or VHS. DVD has 45 min. extras \$19.95

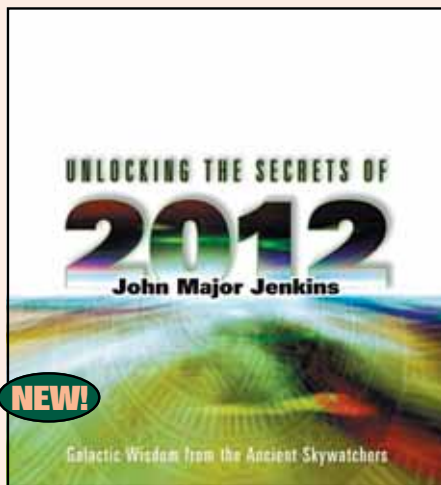

UNLOCKING THE SECRETS OF 2012: Galactic Wisdom from the Ancient Skywatchers (Audiobook) *John Major Jenkins*—Did the ancient Mayans predict that the "world will end" in 2012; or is that a modern misinterpretation of their true message? Respected author and researcher, John Major Jenkins, goes to the source—the original Mayan calendar found in the city of Izapa—to find the surprising answers. Listeners will learn how the Mayan mystics based their myths and prophecies on a deep understanding of cycles—their beginnings, their endings, and how the impending ending-cycle impacts our lives. According to Jenkins, the Mayan legacy offers teachings to help us understand 2012.

3 CDs, 210 min. \$24.95

WHAT THE BLEEP!? DOWN THE RABBIT HOLE—One Movie, Infinite Possibilities

Proving once and for all that life can be an amazing journey—and a real trip—this all-new Quantum Edition release, *What the Bleep? Down the Rabbit Hole*, utilizes cutting-edge DVD technology to create a unique version of the film with every viewing! (This set has special branching and randomization options that allow you to dive as deep down the rabbit hole as you want to go or never see the same version twice, if you so choose. However, not all DVDs are equipped with the technology to handle these features.) The possibilities are endless...and so is the fun!

DVD - 3 discs, 6 sided - 5 hrs. \$26.95

WISDOM OF YOUR CELLS: How Your Beliefs Control Your Biology

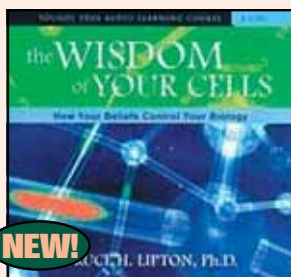

Dr. Bruce H. Lipton (Biology of Belief/The New Biology book and DVD)

This is the only lesson you'll ever need on quantum physics and cellular biology. Lipton's love of teaching, his enthusiastic speaking style, and his practical grasp of biophysics make this audio highly accessible. He says that cell membranes are like TV receivers, picking up energy from our thoughts, from other people, and from the universe. Thinking about living organisms in terms of matter or mere heredity overlooks the web of energy that links everyone and everything in the tangible world. Lipton says that genes change according to the signals they "read" from the environment in continuous feedback loops. This phenomenon and our unique capacity for awareness could delay the sixth great human extinction and further our evolutionary ascension.

8 CDs - 8 hours \$79.95

CD ROM



SOUND WAVE ENERGY—FOUNDATION SERIES

Nicole LaVoie—The seven chakra recordings contain the frequencies of the building block of the body (amino acids, hormones, minerals, noble gases, and vitamins.) Your body will re-attune to these frequencies, which will enable you to assimilate them from the foods you eat. The specific combination of the frequencies on the recordings will bring balance to the elements that we have too much of, thus eliminating toxicity. The other recordings will remove resistance and stress, balance both sides of the brain, release unhealthy emotions, and encourage unconditional love.

12 CDs plus a complimentary copy of the book, "Return to Harmony,"

the autobiography of founder, *Nicole LaVoie*, plus one free CD—"Prana" (helps you breathe better) or "Cal Mag" (helps you assimilate calcium better)—your choice.

\$288.00



RADIANT BODY SERIES—SOUND WAVE ENERGY *Nicole LaVoie*

- Harmonic Structure CD—designed to help the cartilage, tendons, ligaments and bones function properly.
- Vibrant Expression CD—developed to assist in cleansing and energizing the blood so it can carry toxins out of the body and nutrients into the body, to promote cellular changes to the root cells of the skin, hair and nails.
- Physical Senses CD—designed to strengthen and increase the acuity of the senses of hearing, vision, smell and taste.
- Muscles CD—designed to tone muscles, help the release of lactic acid after physical work and bring a sense of deep relaxation throughout the body.
- Ultimate Lovemaking CD—designed to enhance sexual function, providing energy that will give a greater sensuality, enhance kinesthetic ability and heighten our sense of touch.

5 CD Set plus book, "Return to Harmony" \$125.00

ATLANTIS RISING

Order Form

**10% Discount
on orders
over \$100!**

To order from the catalog or our house ads, and to subscribe, you have the following options:

- TELEPHONE - Use your credit card (Mastercard, Visa or American Express) and call our toll-free number 800-228-8381.
- INTERNET - Use the shopping basket on our website at www.AtlantisRising.com (not always current on available products).
- E-MAIL - Send your order to darsi@atlantisrising.com. (Be sure to include your credit card number and expiration date.)
- POSTAL - Copy, fill out and mail this order form to:
Atlantis Rising, P.O. Box 441, Livingston, MT 59047.
Include your check, money order, or credit card information.
- FAX - Same procedure as with postal. Be sure to include your credit card information. Our fax number is 406-222-3078.

Use this form to order items from our catalog and house ads located elsewhere in the magazine:

Classified Advertising
Alternative science books
Atlantis Rising back issues & PDFs
Clash of the Geniuses (video)
English Sacred Sites (video)
Technologies of the Gods (video)
Sale books, videos, DVDs & CDs
Subscriptions (standard)
Subscriptions (foreign & 1st class:
see subscription Mailing Policies)

MAKE COPIES OF THIS ORDER BLANK, SO THAT YOU CAN USE IT AGAIN!

Date Phone

BILL TO:

First Name Last Name

Address

City St. Zip

SHIP TO (if different from bill to):

First Name Last Name

Address

City St. Zip

Qty	Item	Unit Price	Total
MERCHANDISE TOTAL			

Deduct 10% when merchandise totals \$100 or more. →
(offer does not apply to already discounted subscriptions or special sale items such as group set offers)

Payment Method

Card #

Exp. Dt.

We accept checks,
money orders,
or credit cards:



TOTAL LESS DISCOUNT	
SHIPPING & HANDLING*	
ORDER TOTAL	
AMOUNT ENCLOSED	

All products sold by *Atlantis Rising* have a 30-day money-back guarantee against defects in materials and workmanship.

Products offered for sale by *Atlantis Rising* are made available in order to provide our customers with commercial choices difficult to obtain elsewhere. However, the appearance of any product in these pages, does not constitute an endorsement or guarantee by this publication. Any inaccuracies or invalid commentary in the contents, or problems with the quality of presentation, in any material offered are the sole responsibility of the producer of the material. Moreover, *Atlantis Rising* makes no claims or guarantees, express or implied, concerning the worth, appropriateness, or efficacy of any philosophies, remedies or strategies associated with any products sold or advertised in this magazine.

*Shipping and handling charge is \$5.95 for the first item and \$2.50 for each additional item, unless ad states differently.



SACRED GEOMETRY A FOUNDATION TRAINING



**NOVEMBER 3-9, 2007 IN ASHEVILLE, NORTH CAROLINA
WITH DR. ROBERT J. GILBERT AND GUESTS**

Sacred Geometry reveals the precise patterns which create everything in both the physical and spiritual worlds. Every major spiritual tradition uses this Divine Science, previously kept secret for thousands of years.

This course reveals essential principles and patterns taught to Initiates around the world, opening up vast new insights into the patterns which govern our lives.

- ❖ *A Complete Education in Essential Sacred Geometry*
- ❖ *No Difficult Mathematics, Topics Richly Illustrated*
- ❖ *Profound Teachings & Practices from over a dozen of the World's Great Spiritual Traditions (Egyptian, Greek, Celtic, Hebrew Kabbalah, Indian, Chinese etc.)*
- ❖ *Beautiful Mountain Retreat Location, Near Airport*

Skills and Topics You Will Learn Include:

- ▶ *Classical Sacred Geometry Drawing Practices*
- ▶ *3-D Constructions of Essential Forms*
- ▶ *Energy Effects of Sacred Geometry Patterns*
- ▶ *Core Patterns behind the Natural World, the Human Energy Field, and Modern Science & Technology*
- ▶ *Geometric Meditation and Movement Practices*
- ▶ *Key Principles for Sacred Architecture & Design*
- ▶ *Patterns used for Spiritual and Energy Healing*

TUITION: Full 7-day Intensive:
\$995 by 10/19, \$1150 thereafter

Opening Weekend only: \$295 by 10/19, \$340 thereafter
Register Early! Limited Seating.

**SEE OUR WEBSITE FOR FULL INFORMATION ON THIS TRAINING
PLUS SACRED GEOMETRY TOOLS, BOOKS & DVDS**

WWW.VESICA.ORG

(828) 257-2600 INFO@VESICA.ORG



A SUPER NATURAL COMPANY

WWW.

herbalhealer
.COM

*GLOBAL SUPPLIER OF
SAFE, NATURAL MEDICINE,
CORRESPONDENCE
EDUCATION AND
RESEARCH*



**HEALING THE WORLD
WITH NATURE**

...one person and pet at a time!

Since 1988