

H.S.R.

516
1962
MISSIE
BXc1-3
070
c.2



OVERSEAS INSTITUTE
OF CANADA



INSTITUT CANADIEN
D'OUTRE-MER

151 BLOOR ST. W.,
TORONTO 6.

THE OVERSEAS BOOK CENTRES
CENTRES DU LIVRE POUR OUTRE-MER
CANADA

INTERNET ARCHIVE



Digitized for Microsoft Corporation
by the Internet Archive in 2008.

From University of Toronto.

May be used for non-commercial, personal, research,
or educational purposes, or any fair use.

May not be indexed in a commercial service.

ΤΑ ΕΥΚΛΕΙΔΟΥ ΣΤΟΙΧΕΙΑ.

The High School Euclid

Euclid's Elements

BOOKS I, II, III

BY

ALEXANDER CHARLES McKAY, B.A.

*Professor of Mathematics, McMaster University
Toronto*

AND

ROBERT ALLEN THOMPSON, B.A.

*Principal of Collegiate Institute, and Vice-Principal
of Normal College, Hamilton*

AUTHORIZED BY THE DEPARTMENT OF EDUCATION

TORONTO
THE HUNTER, ROSE COMPANY, Limited
1902

Digitized by Microsoft®

Entered according to Act of the Parliament of Canada, in the year one thousand
nine hundred and two, by the HUNTER, ROSE COMPANY (LIMITED), at the
Department of Agriculture.

Ministry of Education, Ontario
Historical Collection

PRESS OF THE HUNTER, ROSE CO., LIMITED

Digitized by Microsoft®

PREFACE.

THIS edition of Euclid's Elements has been prepared for the use of pupils in High Schools and Collegiate Institutes, and is essentially a pupil's text-book.

The proofs of the propositions have been arranged, as far as possible, to avoid the necessity of giving references by number to former propositions. This is only a return to Euclid's method, for he gave no such references. References are properly given for the purpose of aiding the student in learning the proofs, but they have been so mis-used in the attempt to abbreviate the proofs that in many text-books they have become a part of the proof itself. The gain thus made in the time of writing a proposition is lost in the obscurity of the demonstration.

In connection with the earlier part of Book I, some introductory questions are prefixed to each proposition. These questions are intended to help the pupil in acquiring power to attack original exercises, and experience has shown that good results are obtained from their use.

In Propositions 4 to 8 of Book II, the well-known proofs, without the use of the diagonal of the square, have been given. Euclid's method is more cumbrous, and although of value in the solution of problems by purely geometrical methods, it has generally given way to the algebraical method which is more powerful.

Alternative proofs of the propositions of Book II have been given, and it is hoped that pupils will be encouraged by these to make a more careful study of this section of Euclid's work.

In Book III, the usual proofs are given, except in the case of Propositions 26 to 29, in which the method of superposition is used.

The exercises given in connection with the propositions are simple and are such as an average pupil may be expected to solve. The exercises at the end of the different books are more difficult, but are arranged so that the teacher may select those which are suitable for his class.

CONTENTS

BOOK I.

	PAGE
Euclid.	1
Definitions.	3
Postulates.	8
Axioms.	8
Symbols and Abbreviations.	10
Propositions 1-48	12-88
Exercises—	
Equilateral Triangle.	89
Isosceles Triangle.	90
Triangle.	93
Quadrilateral.	99
Miscellaneous.	105
Loci.	109

BOOK II.

Definitions.	113
Propositions A, B, C.	114-116
Propositions 1-14.	117-142
Exercises—	
Miscellaneous	143
Loci	151

BOOK III.

Definitions.	153
Propositions 1-37	155-202
Exercises—	
Problems	203
Miscellaneous	207
Loci	225

EUCLID

EUCLID was the first teacher of mathematics in the great university founded at Alexandria, in Egypt, about 300 B.C. Very little is known concerning his life.

The work known as Euclid's Elements probably formed the course of mathematics taught by Euclid to his classes. It consists of thirteen books, of which the first four and the sixth treat of plane geometry; the fifth of the theory of proportion; the seventh, eighth and ninth, of arithmetic; the tenth, of incommensurable magnitudes; the eleventh and twelfth, of solid geometry; the thirteenth, partly of plane and partly of solid geometry.

The proofs of the propositions in this edition of the first six books differ but little from those given by Euclid. They have been used ever since his time as models of deductive reasoning, and their form should be studied as well as the geometrical facts which they present.

EUCLID'S ELEMENTS

BOOK I.

THE DEFINITIONS

In his definitions, Euclid named the things with which he proposed to deal, and stated the distinguishing marks by which these things were to be recognized.

1. **Point.**—That which has position but not magnitude, is called a point.

2. **Line.**—That which has position and length but has neither breadth nor thickness, is called a line.

The extremities of a line are points, and the intersection of two lines is a point. A line is indicated by a stroke. A point is indicated by a dot, or by the intersection of two strokes, or by the end of a stroke.

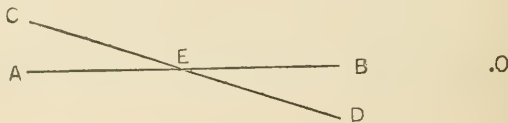

Thus we speak of the line AB, or of the line CD.

A, E, O indicate points.

3. **Straight line.**—A line which lies evenly between its extreme points is called a straight line.

4. **Surface.**—That which has position, length and breadth, but not thickness, is called a surface.

The boundaries of a surface are lines.

5. **Plane.**—A plane surface (or a plane) is a surface in which, if any two points be taken, the straight line joining them lies wholly in that surface.

6. **Angle.**—The inclination to one another of two straight lines which meet but are not in the same straight line is called an angle.

The point at which the lines meet is called the vertex and the lines themselves are commonly called the arms of the angle.

An angle is usually named by three letters, one denoting the vertex, and the others points on the arms, the middle letter always denoting the vertex.

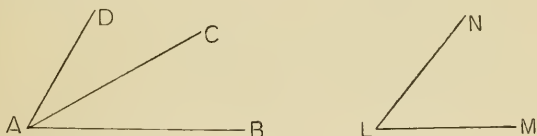

Thus the angle formed by the straight lines AB and AC is called the angle BAC or CAB. The angle formed by the straight lines LM and LN is called the angle MLN or NLM. In this latter case, where only two straight lines meet at the point L, the angle may be called the angle L.

Two angles, such as BAC and CAD, which have a common vertex and are on opposite sides of a common bounding line, are called adjacent angles.

The angle formed by two straight lines is sometimes called a **rectilinear** angle, to distinguish it from an angle formed by a curved line and a straight line, or by two curved lines.

7. **Right angle, perpendicular.**—When a straight line standing on another straight line makes the adjacent angles equal to one another, each of the angles is called a right angle; and the straight line which stands on the other is called a perpendicular to it.



The straight lines are also said to be at right angles to each other.

8. **Obtuse angle.**—An angle which is greater than a right angle, is called an obtuse angle.



9. **Acute angle.**—An angle which is less than a right angle, is called an acute angle..

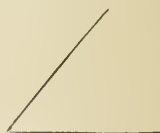

When the sum of two angles is a right angle each is called the **complement** of the other, and the two angles are said to be **complementary**.

When one straight line meets another, each of the two angles formed is called the **supplement** of the other, and the two angles are said to be **supplementary**.

Thus, if DB is perpendicular to AC , the angles DBE and EBC are complementary. The angles EBA and EBC are supplementary.

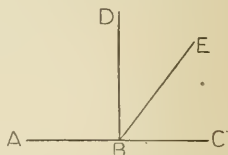

10. **Plane figure.**—Any portion of a plane surface bounded (or contained) by one or more lines is called a plane figure.

The term figure is also commonly used in plane geometry to denote any combination of points and lines.

In the first six books of his Elements, Euclid deals with plane figures only.

11. **Circle, circumference, centre.**—A circle is a plane figure contained by one line called the circumference, and is such that all straight lines drawn from a certain point within the figure to the circumference are equal to one another. This point is called the centre.

A circle is usually named by three letters, each of which denotes a point on the circumference..

12. **Radius.**—A straight line drawn from the centre to the circumference of a circle is called a radius.

13. **Diameter.**—A straight line drawn through the centre and terminated both ways by the circumference is called a diameter.

Thus, in the figure, ABC is a circle, of which O is the centre; OA, OB, OC are radii; AC is a diameter.

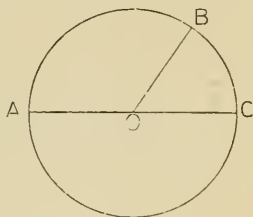

14. **Parallel straight lines.**—Straight lines, which lie in the same plane, and which do not meet however far they may be produced both ways, are said to be parallel to one another.

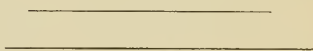

15. **Rectilinear figure.**—A figure which is contained by straight lines is called a rectilinear figure.

These straight lines are called the **sides** of the figure, and the sum of their lengths is called the **perimeter** of the figure.

16. **Triangle.**—A plane figure contained by three straight lines is called a triangle.

The angular points of a triangle are called its **vertices**. When two sides of a triangle have already been referred to, the third side is commonly called the **base**, and the angular point opposite to that side is called the **vertex**.

17. **Equilateral triangle.**—A triangle which has its three sides equal is called an equilateral triangle.



18. **Isosceles triangle.**—A triangle which has two equal sides is called an isosceles triangle.



19. **Scalene triangle.**—A triangle which has three unequal sides is called a scalene triangle.

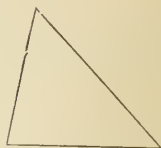

20. **Right-angled triangle.**—A triangle which has one of its angles a right angle is called a right-angled triangle.

The side opposite to the right angle in a right-angled triangle is called the **hypotenuse**.

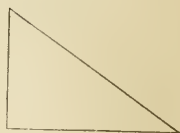

21. **Obtuse-angled triangle.**—A triangle which has an obtuse angle is called an obtuse-angled triangle.



22. **Acute-angled triangle.**—A triangle which has three acute angles is called an acute-angled triangle.

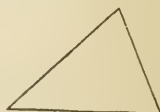

23. **Quadrilateral.**—A plane figure contained by four straight lines is called a quadrilateral.

The straight line which joins two opposite angular points of a quadrilateral is called a **diagonal**.

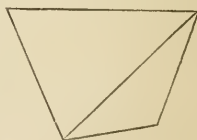

24. **Rhombus.**—A quadrilateral which has all its sides equal is called a rhombus.



25. **Square.**—A quadrilateral which has all its sides equal and all its angles right angles is called a square.



26. **Parallelogram.**—A quadrilateral whose opposite sides are parallel is called a parallelogram.

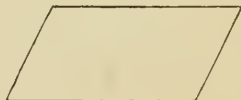

27. **Rectangle.**—A quadrilateral whose opposite sides are parallel and whose angles are right angles is called a rectangle.

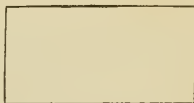

28. **Polygon.**—A plane figure contained by more than four straight lines is called a polygon.

The straight line joining any two vertices of a polygon, which are not extremities of the same side, is commonly called a diagonal.

THE POSTULATES

It is not possible, even with the best of instruments, to draw straight lines or circles. But since Euclid wished to reason about figures made up of straight lines and circles, he requested that his attempts to draw these be considered successful. He made these requests in his three postulates.

Let it be granted :

1. That a straight line may be drawn from any one point to any other point.
2. That a terminated straight line may be produced to any length either way.
3. That a circle may be described with any centre, and at any distance from that centre.

THE AXIOMS

In the axioms, Euclid made twelve simple statements, the truth of which he claimed to be self-evident. The first seven and the ninth are general axioms, that is, truths referring to magnitudes of all kinds. The eighth, tenth, eleventh and twelfth are statements concerning geometrical magnitudes, which Euclid claimed as self-evident.

These axioms form the foundation on which the whole science of geometry is built. They should be committed to memory.

1. Things which are equal to the same thing are equal to one another.

2. If equals be added to equals, the sums are equal.
3. If equals be taken from equals, the remainders are equal.
4. If equals be added to unequals, the sums are unequal.
5. If equals be taken from unequals, the remainders are unequal.
6. Things which are doubles of the same thing are equal to one another.
7. Things which are halves of the same thing are equal to one another.
8. Magnitudes which coincide with one another are equal to one another.
9. The whole is greater than its part.
10. Two straight lines cannot enclose a space.
11. All right angles are equal to one another.
12. If a straight line cuts two other straight lines, so as to make the interior angles on one side of it together less than two right angles, these two straight lines will meet if continually produced on the side on which are the angles which are together less than two right angles.

SYMBOLS AND ABBREVIATIONS

The following symbols and abbreviations are used in the propositions :

∴	for 'because.'	
∴	" 'therefore.'	
∠, ∠s	" 'angle,' 'angles.'	
Δ, Δs	" 'triangle,' 'triangles.'	
○, ○s	" 'circle,' 'circles.'	
○ce	" 'circumference.'	
=	" 'is equal to,' 'are equal to,' 'be equal to,' 'equal to.'	
∥	" 'is parallel to,' 'parallel to,' 'parallel.'	
∥ m, ∥ ms	" 'parallelogram,' 'parallelograms.'	
⊥	" 'is perpendicular to,' 'perpendicular to,' 'perpendicular.'	
+	" 'together with.'	
st.	" 'straight.'	parl. for 'parallel.'
rt.	" 'right.'	hyp. " 'hypothesis.'
pt.	" 'point.'	constr. " 'construction.'
quad.	" 'quadrilateral.'	def. " 'definition.'
sq.	" 'square.'	post. " 'postulate.'
rect.	" 'rectangle.'	ax. " 'axiom.'
perp.	" 'perpendicular.'	fig. " 'figure.'

'Join AB' 'From the point A to the point B draw the straight line AB.'

'Produce AB to C' 'Produce the straight line AB, terminating the produced line at the point C.'

Other abbreviations will be explained and introduced as they are needed.

THE PROPOSITIONS

INTRODUCTION TO PROPOSITION 1.

1. State the definition of a circle, a triangle, an equilateral triangle.
2. What is a Postulate? An Axiom? State Post. 1, Post. 3 and Ax. 1.
3. Make a triangle whose angular points are the points
A, B and C.

B C

4. (a) Find a point which is at the same distance from the point A
that the point B is.

A ————— B

- (b) In what line do all such points lie?
- (c) Draw a line every point of which will be at the same distance
from B that A is.
- (d) Make an isosceles triangle having the line AB one of the
equal sides.
- (e) Find a point that is equidistant from A and B.
5. Find a point whose distance from each of the extremities of a
given straight line is equal to the length of the straight line.
6. Show how to describe an equilateral triangle on a given straight
line.

PROPOSITION 1. PROBLEM.

To describe an equilateral triangle on a given straight line.

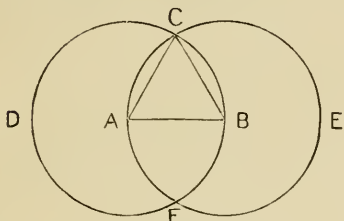

Let AB be the given straight line.

It is required to describe an equilateral triangle on AB .

Construction. With centre A and distance AB ,
describe $\odot BCD$.

Post 3.

With centre B and distance BA , describe $\odot ACE$.

Post 3.

Let the circumferences intersect at the point C .

Join AC and BC .

Post 1.

ABC shall be an equilateral Δ .

Proof. $\because A$ is the centre of $\odot BCD$,

$\therefore AC = AB$.

Def. of \odot .

And, $\because B$ is the centre of $\odot ACE$,

$\therefore BC = AB$.

Def. of \odot .

Now, $\because AC$ and BC are each $= AB$,

$\therefore AC = BC$.

Ax. 1.

Thus AB , BC and AC are all equal,

and an equilateral triangle ABC has been described on AB .

Def. of equilateral Δ .

QUESTIONS ON PROPOSITION 1.

1. If the two circumferences intersect also at F , what kind of triangle will be formed by joining AF and BF ?
2. What kind of quadrilateral is the figure $ACBF$?

INTRODUCTION TO PROPOSITION 2.

1. Define a circle. Is it possible to make a circle on a plane surface with a pair of compasses?

2. State the postulates. State Ax. 2 and Ax. 3.

3. (a) Find a point equidistant from A and B. $A \cdot \quad \cdot B$

(b) Show how to describe a circle that will pass through A and B.

4. ABC and DEF are concentric circles, having as common centre the point O. OD and OE are radii of the circle DEF which cut the circumference of the circle ABC at the points A and B respectively.

(a) Show that AD equals BE.

(b) Draw from G, a point on the circumference ABC, a straight line equal to AD.

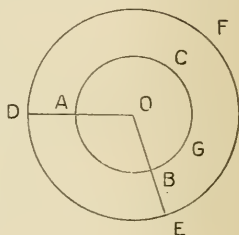

5. A radius of the circle ABC is produced to D. Show how to draw from B a straight line equal to AD.

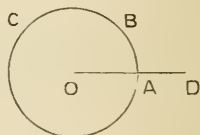

6. When AD is not in the same straight line as OA, show how to draw from B a straight line equal to AD.

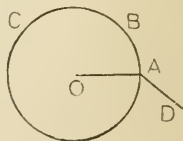

7. From the point B draw a straight line equal to AD.

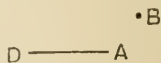

PROPOSITION 2. PROBLEM.

From a given point to draw a straight line equal to a given straight line.

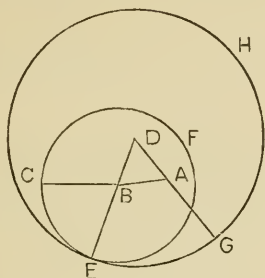

Let A be the given point, and BC the given straight line.

It is required to draw from A a straight line = BC.

Construction. Join AB. *Post.* 1.

On AB describe the equilateral \triangle DAB. *Prop.* 1.

With centre B and distance BC describe \odot CEF. *Post.* 3.

Produce DB to meet the \odot CEF in E. *Post.* 2.

With centre D and distance DE describe \odot EGH. *Post.* 3.

Produce DA to meet the \odot EGH in G. *Post.* 2.

Then $AG = BC$.

Proof. \because D is the centre of \odot EGH,

$\therefore DE = DG$. *Def. of \odot .*

But \because DAB is an equilateral \triangle ,

$\therefore DB = DA$.

\therefore the remainder BE = the remainder AG. *Ax.* 3.

And, \because B is the centre of \odot CEF,

$\therefore BC = BE$. *Def. of \odot .*

But $AG = BE$.

$\therefore AG = BC$. *Ax.* 1.

Thus from the point A a straight line AG has been drawn equal to BC.

QUESTIONS ON PROPOSITION 2.

1. Under what circumstances would the point D lie outside of the circle CEF? On the circumference of the circle CEF?
2. If D were without the circle CEF, would it be necessary to produce DB?
3. Could the problem be solved by producing BD instead of DB?
4. Could the problem be solved by joining AC instead of AB?
5. In how many ways can the construction be made generally?
6. Does the line AG always lie in the same direction, no matter which of the above methods of construction is used?

INTRODUCTION TO PROPOSITION 3.

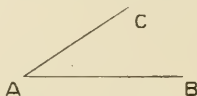

AB and AC are two straight lines of which AB is the greater. Show how to cut off from AB a part equal to AC.

PROPOSITION 3. PROBLEM.

From the greater of two given straight lines to cut off a part equal to the less.

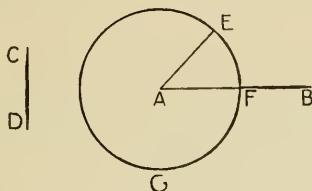

Let AB and CD be the two given straight lines, of which AB is the greater.

It is required to cut off from AB a part = CD.

Construction. From A draw the st. line $AE = CD$. *Prop. 2.*

With centre A and distance AE describe $\odot EFG$, *Post. 3.*
cutting AB in F.

Then $AF = CD$.

Proof. \because A is centre of $\odot EFG$,

$\therefore AF = AE$.

Def. of \odot .

But $CD = AE$.

Constr.

$\therefore AF = CD$,

Ax. 1.

and AF has been cut off from CD.

QUESTIONS ON PROPOSITION 3.

1. Why not say "with centre A and distance CD describe $\odot EFG$, cutting AB in F"?
2. Could the required part be cut off from either end of the line AB?
3. Make the figure, putting in the construction necessary to draw AE equal to CD.

EXERCISES.

Find the solutions of the following exercises, and write the proof of each solution in a form similar to that used by Euclid in his propositions:

1. AB is a given straight line. Produce the line, making the whole length double that of AB. A————B
2. Describe an isosceles triangle on a given straight line, such that each of the equal sides shall be twice as long as the given line.
3. On a given straight line describe an isosceles triangle having each of the equal sides equal to another given straight line. Is this always possible?
4. Draw a straight line three times as long as a given straight line.
5. On a given straight line describe an isosceles triangle having each of the equal sides three times as long as the given line.
6. From a given point C, in a given straight line AB, draw a straight line equal to AB.
7. Produce the less of two given straight lines, making it equal to the greater.
8. Construct a rhombus having each of its sides equal to a given straight line.
9. Draw from a given point a straight line which shall be equal to the sum of two given straight lines.

INTRODUCTION TO PROPOSITION 4.

NOTE.—Euclid assumed that any geometrical figure could be moved from one position into another without changing its shape or size. By placing one figure upon another, he compared them in size. This method is called the method of superposition, and the one figure is said to be applied to the other. Sometimes the figure must be conceived to be turned over before it can be made to coincide with the other.

1. State Ax. 8, and Ax. 10.
2. What is the meaning of 'coincide'?
3. Are two angles necessarily equal, if the straight lines which form the angles are equal, each to each?
4. Two circles have equal radii: show that they have equal areas and equal circumferences.
5. Two squares have the sides of the one equal to the sides of the other. Show that they have equal areas and equal perimeters.



PROPOSITION 4. THEOREM.

If two triangles have two sides of the one equal to two sides of the other, each to each, and have also the angles contained by those sides equal, they shall have their third sides equal; and the two triangles shall be equal, and the other angles shall be equal, each to each, namely those to which the equal sides are opposite.



In the Δ s ABC and DEF,
 let $AB = DE$,
 $AC = DF$,
 and included $\angle BAC =$ included $\angle EDF$.

It is required to prove $BC = EF$,
 $\Delta ABC = \Delta DEF$,
 $\angle ABC = \angle DEF$,
 and $\angle ACB = \angle DFE$.

Proof. If ΔABC be applied to ΔDEF , so that A falls on D, and AB falls on DE,

then $\because AB = DE$, *Hyp.*

$\therefore B$ will coincide with E.

And, $\because AB$ coincides with DE,

and $\angle BAC = \angle EDF$, *Hyp.*

$\therefore AC$ will fall on DF.

And $\because AC = DF$,

Hyp.

$\therefore C$ will coincide with F.

And, $\because B$ coincides with E, and C with F,

$\therefore BC$ will coincide with EF.

For, if not, two straight lines, BC and EF, would enclose a space, which is impossible. *Ax. 10*

Hence BC coincides with EF and $\therefore BC = EF$, Ax. 8.
 $\triangle ABC$ " " $\triangle DEF$ and $\therefore \triangle ABC = \triangle DEF$,
 $\angle ABC$ " " $\angle DEF$ and $\therefore \angle ABC = \angle DEF$,
 and $\angle ACB$ " " $\angle DFE$ and $\therefore \angle ACB = \angle DFE$.

QUESTIONS ON PROPOSITION 4.

1. State the axioms used in the proof.
2. Are the words, 'each to each,' necessary in the enunciation?
3. Does AC necessarily fall on DF, if AB coincides with DE?
4. Prove the proposition, beginning the superposition by applying B to E.

EXERCISES.

1. The sides of the square ABCD are equal to the sides of the square EFGH.

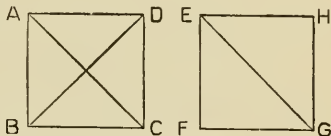

Show that

- (a) The diagonals AC and EG are equal.
 - (b) The diagonals AC and BD are equal.
 - (c) The diagonal AC bisects, that is, divides into two equal parts, the angle BAD.
 - (d) The squares are equal in area.
2. A straight line AD bisects the vertical angle BAC of the isosceles triangle ABC, and meets the base at the point D. Show that D is the middle point of the base, and that AD is perpendicular to BC.
 3. If two straight lines bisect each other at right angles, any point in either of them is equidistant from the extremities of the other.
 4. The middle points of the sides of a square are joined in order. Show that the quadrilateral formed by these joining lines is equilateral.
 5. ABCD is a square, E is a point in AB, and F is a point in CD, such that AE is equal to CF; EF is joined. Show that the angle AEF is equal to the angle CFE.

INTRODUCTION TO PROPOSITION 5.

1. Define isosceles triangle. Which side of an isosceles triangle is called the base?
2. In the accompanying figure point out and name the angle which is
 - (a) The sum of the angles ABC and CBD.
 - (b) The difference of the angles ABD and CBD.
3. In the figure, AB is equal to AD, and AC is equal to AE.
 - (a) Join BE and DC. Name the parts of the Δ s ACD and AEB, which are equal.
 - (b) Prove that CD is equal to BE.
 - (c) Join BD. Name all the parts of the Δ s BCD and DEB, which are equal.
 - (d) What kind of triangle is Δ ABD?

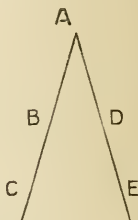
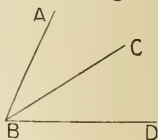

PROPOSITION 5. THEOREM.

The angles at the base of an isosceles triangle are equal; and if the equal sides be produced, the angles on the other side of the base shall also be equal.

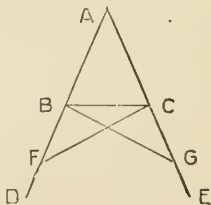

In $\triangle ABC$, let $AB = AC$, and let AB and AC be produced to D and E .

It is required to prove $\angle ABC = \angle ACB$,
and $\angle DBC = \angle ECB$.

Construction. In BD take any point F ,
and from AE cut off $AG = AF$. *Prop. 3.*

Join BG and CF . *Post. 1.*

Proof. In $\triangle s$ AFC and AGB ,

$AF = AG$, *Constr.*

$AC = AB$, *Hyp.*

and included $\angle FAC =$ included $\angle GAB$,

$\therefore FC = GB$,

$\angle AFC = \angle AGB$,

and $\angle ACF = \angle ABG$. *Prop. 4.*

Again, \therefore the whole $AF =$ the whole AG ,

and the part $AB =$ the part AC ,

\therefore the remainder $BF =$ the remainder CG . *Ax. 3.*

And in $\triangle s$ BFC and CGB ,

$BF = CG$,

$FC = GB$,

and included $\angle BFC =$ included $\angle CGB$,

$\therefore \angle BCF = \angle CBG$,

and $\angle FBC = \angle GCB$. *Prop. 4.*

Now, \therefore the whole $\angle ABG =$ the whole $\angle ACF$,

and the part $\angle CBG =$ the part $\angle BCF$,

\therefore the remainder $\angle ABC =$ the remainder $\angle ACB$, *Ax. 3.*

and these are the angles at the base.

It has also been proved that $\angle FBC = \angle GCB$, that is $\angle DBC = \angle ECB$, and these are the angles on the other side of the base.

Corollary. It is evident that if a triangle has all its sides equal, it has all its angles equal; that is, an equilateral triangle is equiangular.

A truth, such as the above, which is easily and directly inferred from a proposition, is called a corollary of that proposition.

Propositions are divided into two classes, **theorems** and **problems**.

A proposition is called a **theorem** when some property of a geometrical figure has to be proved. It is proved by means of the axioms or other geometrical truths already established.

A proposition is called a **problem** when some geometrical figure has to be constructed. The construction is made by means of the principles of construction granted in the postulates, or proved in previous problems.

The **enunciation**, or statement, of a theorem consists of two parts, the **hypothesis**, which states that which is assumed, and the **conclusion**, which states that which is asserted to follow from the hypothesis.

The hypothesis of Prop. 4 is, "If two triangles have two sides of the one equal to two sides of the other, each to each, and have also the angles contained by those sides equal to each other," the conclusion is "they shall have their third sides equal, and the two triangles shall be equal, and the other angles shall be equal, each to each, namely those to which the equal sides are opposite."

Figures which may be made to coincide, are said to be "equal in all respects," or **congruent**.

The three sides and the three angles of a triangle are called the "parts of the triangle."

Thus, the triangles considered in Prop. 4, are proved to be equal in all respects, since the parts of the one are equal to the corresponding parts of the other.

QUESTIONS ON PROPOSITION 5.

1. What is the hypothesis of Proposition 5?
2. What is the conclusion of Proposition 5?
3. Would it do equally well to say "In AD take any point F"?

EXERCISES.

1. Prove that the diagonal of a rhombus divides it into two isosceles triangles.
2. Prove that the opposite angles of a rhombus are equal.
3. Prove that the diagonal of a rhombus bisects each of the angles through which it passes.
4. Two isosceles triangles, ABC and DBC , have the same base BC .
 (a) Prove that the angle ABD is the angle to ACD .
 (b) Prove that the angle BAD is equal to the angle CAD .
 (c) Prove that AD , or AD produced, bisects the base BC .
5. ABC is an isosceles triangle; and in the base BC two points D, E are taken such that $BD = CE$; prove that ADE is an isosceles triangle.
6. Prove that the diagonals of a square divide the figure into four isosceles triangles.
7. Two equal circles, whose centres are A and B , intersect at the point C . Join CA and CB , and produce them to meet the circumferences at D and E respectively. Join DE . Prove that the angle CDE equals the angle CED .
8. ABC is an equilateral triangle: D, E and F are points in the sides AB, BC and CA , such that $AD = BE = CF$. Show that the triangle DEF is equilateral.

INTRODUCTION TO PROPOSITION 6.

1. There are two straight lines, AB and CD .
 (a) If AB is not greater than CD , must AB be less than CD ? Why?
 (b) If AB is not equal to CD , is AB necessarily greater than CD ?
 (c) If AB is not greater than CD , nor less than CD , what relation must exist between AB and CD ?
2. In the figure, $AB = DC$, and $\angle ABC = \angle DCB$; prove that $AC = BD$, and that $\triangle ABC = \triangle DCB$.

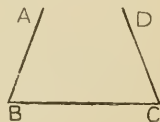

PROPOSITION 6. THEOREM.

If two angles of a triangle be equal, the sides opposite them shall also be equal.

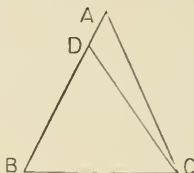

In $\triangle ABC$, let $\angle ABC = \angle ACB$.

It is required to prove $AC = AB$.

Construction. If AC is not $= AB$, one of them must be the greater.

Suppose AB to be the greater.

From BA cut off $BD = AC$.

Prop. 3.

Join DC .

Post. 1.

Proof. In $\triangle s$ DBC and ACB ,

$DB = AC$,

Constr.

$BC = CB$,

and included $\angle DBC =$ included $\angle ACB$,

Hyp.

$\therefore \triangle DBC = \triangle ACB$.

Prop. 4.

But this is impossible, $\therefore \triangle DBC$ is a part of $\triangle ACB$.

$\therefore AB$ is not greater than AC .

Similarly it may be shown that AB is not less than AC .

$\therefore AB = AC$.

Corollary. An equiangular triangle is equilateral.

QUESTIONS ON PROPOSITION 6.

1. How would you proceed to show "that AB is not less than AC "?
2. What is the hypothesis of Proposition 6?
3. What is the conclusion of Proposition 6?
4. What relation exists between the hypothesis of Prop. 5 and the conclusion of Prop. 6; and also between the first part of the conclusion of Prop. 5 and the hypothesis of Prop. 6?

Two propositions are said to be **converse**, when the hypothesis of each is the conclusion of the other.

EXERCISES.

1. The diagonals of the square $ABCD$ intersect at E . Use Prop. 6 to prove that the triangle EAB is isosceles.
2. Prove that the diagonals of a rhombus bisect each other at right angles.
3. Show that the straight lines which bisect the angles at the base of an isosceles triangle, form with the base a triangle which is also isosceles.
4. In the figure of Prop. 1, if the straight line AB be produced both ways, to meet the one circumference at D and the other at E , show that the triangle CDE is isosceles.

INTRODUCTION TO PROPOSITION 7.

1. AB and CD are two straight lines, and $CE = AB$.

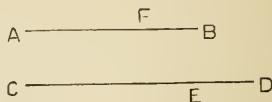

(a) How does AF compare in length with CE?

(b) How does AF compare in length with CD?

2. ABC and DEF are two angles, and $\angle ABC = \angle HEF$, which is a part of $\angle DEF$.

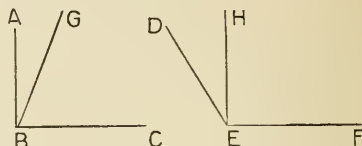

(a) How does $\angle GBC$ compare in magnitude with $\angle HEF$?

(b) How does $\angle GBC$ compare in magnitude with $\angle DEF$?

3. Show that two isosceles triangles cannot stand on the same base and on the same side of it, unless the vertex of the one triangle falls inside the other triangle.
4. Two triangles have the three sides of the one respectively equal to the three sides of the other. Can they be made to coincide?

PROPOSITION 7. THEOREM.

If two triangles on the same base and on the same side of it have one pair of conterminous sides equal, the other pair cannot be equal.

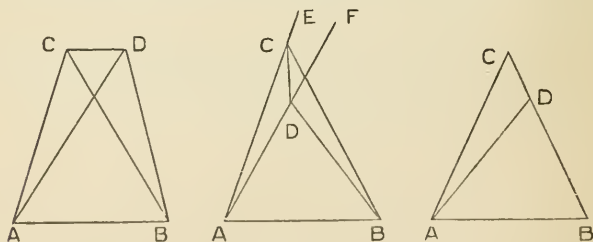

Let the two Δ s ABC, ABD, on the same base AB, and on the same side of it, have $AC = AD$.

It is required to prove that BC cannot $= BD$.

1. **Construction.** In the figure where the vertex of each Δ is without the other Δ ,

join CD .

Proof. In ΔACD , $\because AC = AD$,

$\therefore \angle ACD = \angle ADC$. *Prop. 5.*

But $\angle ACD$ is greater than its part, $\angle BCD$. *Ax. 9.*

$\therefore \angle ADC$ is greater than $\angle BCD$.

Much more then is $\angle BDC$ greater than $\angle BCD$.

If $BC = BD$, then $\angle BDC = \angle BCD$, *Prop. 5.*

which is not true.

$\therefore BC$ is not $= BD$.

2. **Construction.** In the figure where the vertex D falls within the ΔABC ,

join CD , and produce AC and AD to E and F .

Proof. In ΔACD , $\because AC = AD$, and these sides are produced,

$\therefore \angle ECD = \angle FDC$. *Prop. 5.*

But $\angle ECD$ is greater than $\angle BCD$,

$\therefore \angle FDC$ is greater than $\angle BCD$.

Much more then is $\angle BDC$ greater than $\angle BCD$, and, as before, $\therefore BC$ is not $= BD$.

3. In the figure where the vertex D falls on the side BC of the ΔABC ,

BC is evidently not $= BD$.

EXERCISES.

1. Show that only two equilateral triangles can be described on the same base, one on each side.
2. Show that only two isosceles triangles can be described on the same base, having the equal sides of given length.

PROPOSITION 8. THEOREM.

If two triangles have two sides of the one equal to two sides of the other, each to each, and have likewise their bases equal, the angle which is contained by the two sides of the one shall be equal to the angle contained by the two sides, equal to them, of the other.

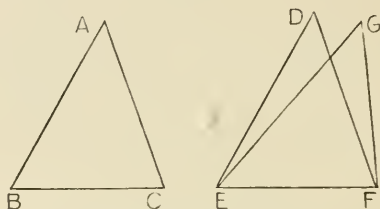

In the Δ s ABC and DEF,
 let AB = DE,
 AC = DF,
 and base BC = base EF.

It is required to prove $\angle BAC = \angle EDF$.

Proof. Apply Δ ABC to Δ DEF,
 so that B is on E and BC on EF.

Then, \because BC = EF,

\therefore C will coincide with F.

Then AB and AC will coincide with DE and DF.

For, if they do not, but fall otherwise, as GE and GF, then on the same base EF, and on the same side of it, there will be two Δ s, DEF and GEF, having equal pairs of conterminous sides,

which is impossible. *Prop.* 7.

\therefore BA coincides with ED; and AC with DF,
 and $\therefore \angle BAC$ with $\angle EDF$; *Ax.* 8.
 $\therefore \angle BAC = \angle EDF$.

Corollary. If two triangles have the three sides of the one respectively equal to the three sides of the other, the triangles are equal in all respects.

QUESTIONS ON PROPOSITION 8.

1. Apply the triangles so that they may fall on opposite sides of the common base EF. Join DG.

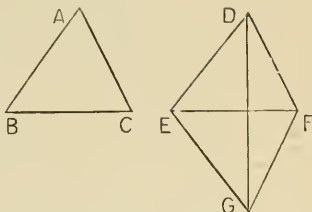

- (a) What kind of a triangle is EDG? FDG?
- (b) Prove that the $\angle EDF = \angle EGF$.
- (c) Prove the proposition in this way when DG does not pass between E and F.
- (d) Prove the proposition when DG passes through the point F.
2. What are the 'parts of a triangle'?
3. (a) What parts were given equal in the two triangles considered in Prop. 4?
- (b) What parts were proved equal?
4. (a) What parts are given equal in Prop. 8?
- (b) What parts are proved equal?
- (c) Are the triangles equal in all respects?
5. Is it possible to make two triangles whose sides are respectively equal to three given straight lines, but which are not equal in all respects?

EXERCISES.

1. The opposite sides of a quadrilateral ABCD are equal. Prove that :
- (a) The opposite angles are equal.
- (b) The angle ABD is equal to the angle CDB.
- (c) The middle point of BD is equidistant from A and C.
2. Two isosceles triangles are on the same base, and on opposite sides of the base. Prove that the line joining their vertices bisects each of the vertical angles.
3. D, E and F are the middle points of the sides of an equiangular triangle; show that the triangle DEF is equiangular.

PROPOSITION 9. PROBLEM.

To bisect a given rectilinear angle.

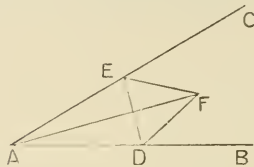

Let BAC be the given rectilinear angle.

It is required to bisect it.

Construction. In AB take any point D ,
and from AC cut off $AE = AD$. *Prop. 3.*

Join DE , and on DE , on the side remote from A ,
describe an equilateral $\triangle DEF$. *Prop. 1.*

Join AF .

AF shall bisect $\angle BAC$.

Proof. In $\triangle s DAF$ and EAF ,
 $DA = EA$, *Constr.*
 $AF = AF$,

and base $DF =$ base EF , *Def. of equilat. \triangle .*

$\therefore \angle DAF = \angle EAF$. *Prop. 8.*

That is, AF bisects $\angle BAC$.

QUESTIONS ON PROPOSITION 9.

1. If the equilateral triangle were described on the same side of DE as A , what different cases would arise?
Under what circumstances would the construction fail?
3. Show that AF bisects DE .
2. Show that AF also bisects the angle DFE .

PROPOSITION 10. PROBLEM.

To bisect a given straight line.

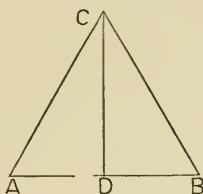
Let AB be the given straight line.

It is required to bisect it.

Construction. On AB describe an equilateral $\triangle ABC$. *Prop. 1.*

Bisect $\angle ACB$ by CD , which meets AB at D . *Prop. 9.*

AB shall be bisected at D .

Proof. In $\triangle s$ ACD and BCD ,

$$AC = BC, \quad \text{Def. of equilat. } \triangle.$$

$$CD = CD,$$

and included $\angle ACD =$ included $\angle BCD$, *Constr.*

$$\therefore AD = BD. \quad \text{Prop. 4.}$$

That is, AB is bisected at D .

QUESTIONS ON PROPOSITION 10.

1. Is it necessary that the triangle described on AB should be equilateral?
2. Show that CD is at right angles to AB .
3. Every point equidistant from A and B lies in the line CD , or CD produced.

EXERCISES.

1. Divide a given angle into four equal parts.
2. Divide a given straight line into eight equal parts.
3. On a given base describe an isosceles triangle such that the sum of its equal sides may be equal to a given straight line.
4. Produce a given straight line so that the whole line may be five times as long as the part produced.
5. ABC is an isosceles triangle, of which AB and AC are the equal sides. Points D and E are taken in AB, and points F and G in AC, such that AD = AF, and AE = AG. CD and BF intersect in H; CE and BG intersect in K.

Prove that :

- (a) AH bisects $\angle DAF$.
 - (b) $\angle BDH = \angle CFH$.
 - (c) $EH = HG$.
 - (d) A, H and K are in the same straight line.
6. Two isosceles triangles, ABC and DBC, stand on the same base BC, but on opposite sides of it. E is the middle point of AB, and F the middle point of AC; and BF and CE intersect at G.
 - (a) Prove that $DE = DF$.
 - (b) Prove that $\angle EDB = \angle FDC$.
 - (c) Prove that $CE = BF$.
 - (d) Prove that $\angle DBF = \angle DCE$.
 - (e) Prove that $\triangle GBC$ is isosceles.
 - (f) Prove that $EG = GF$.
 - (g) Prove that $\angle EGD = \angle FGD$.
 - (h) Prove that A, G and D are in the same straight line.

 INTRODUCTION TO PROPOSITION II.

1. When is one straight line said to be perpendicular to another straight line?
2. ABC is an equilateral triangle, and AD is a straight line bisecting the vertical angle BAC, and meeting the base in D.
 - (a) Show that AD bisects the base.
 - (b) Show that AD is perpendicular to the base.

PROPOSITION 11. PROBLEM.

To draw a straight line perpendicular to a given straight line from a given point in the same.

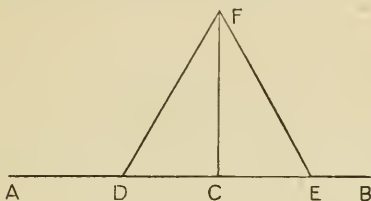

Let AB be the given straight line, and C the given point in it.

It is required to draw from C a st. line $\perp AB$.

Construction. In AC take any point D .

From CB cut off $CE = CD$. *Prop. 3.*

On DE describe an equilateral $\triangle DEF$. *Prop. 1.*

Join CF .

CF shall be $\perp AB$.

Proof. In $\triangle s$ DCF and ECF ,

$DC = EC$, *Constr.*

$CF = CF$,

and base $DF =$ base EF , *Def. of equilat. \triangle .*

$\therefore \angle DCF = \angle ECF$. *Prop. 8.*

$\therefore CF \perp AB$. *Def. of \perp .*

QUESTIONS ON PROPOSITION 11.

1. Is it necessary that the triangle described on DE should be equilateral?
2. If CD were greater than CB , what additional step in the construction would be necessary?
3. Show how to draw a perpendicular from the extremity of the line.
4. Prove that $\angle FDC = \angle FEC$.
5. Can the proposition be proved without the use of Prop. 8?
6. Is Prop. 11 a particular case of Prop. 9?

EXERCISES.

1. In what line do all points lie, which are equidistant from a given point?
2. Find the line in which all points lie which are equidistant from two given points.
3. Find, if possible, a point which is equidistant from three given points.
4. Give a construction for finding the centre of the circle which passes through the three angular points of a triangle.
5. Find a point whose distance from the given point A is equal to a given straight line, and whose distance from a given point B is equal to another given straight line. Is this always possible?

INTRODUCTION TO PROPOSITION 12.

1. Show that the straight line which joins the vertex of an isosceles triangle to the middle point of the base, is perpendicular to the base.
2. Make an isosceles triangle whose vertex is the point C, and whose base is a part of the straight line AB, which is not limited in length.

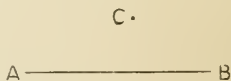

PROPOSITION 12. PROBLEM.

To draw a straight line perpendicular to a given straight line from a given point without it.

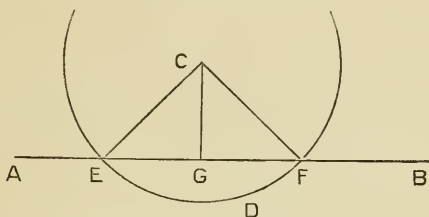

Let AB be the given straight line, and C the given point without it.

It is required to draw from C a st. line $\perp AB$.

Construction. Take any point D on the other side of AB . With centre C and radius CD describe the $\odot EDF$, cutting AB , or AB produced, at E and F .

Bisect EF at G , *Prop.* 10.
and join CG .

CG shall be $\perp AB$.

Join CE , CF .

Proof. In Δ s CGE and CGF ,

$EG = FG$, *Constr.*

$GC = GC$,

and base $CE =$ base CF , *Def. of \odot*

$\therefore \angle CGE = \angle CGF$, *Prop.* 8.

and $\therefore CG \perp AB$. *Def. of \perp .*

QUESTIONS ON PROPOSITION 12.

1. Prove the proposition without the use of Prop. 8.
2. Prove the proposition without the use of Prop. 8 or Prop. 10.
3. Is there any objection to taking the point D ,
 - (a) In the line AB ?
 - (b) On the same side as C ?

EXERCISES.

1. Describe an isosceles triangle, having given the base and the length of the perpendicular drawn from the vertex to the base.
2. In a given straight line find a point that is equidistant from two given points. Is this always possible?
3. From two given points, on opposite sides of a given straight line, draw straight lines to a point in the given line, making equal angles with it. Is this always possible?
4. ABC is a triangle, and D, E and F are the middle points of the sides, BC, CA and AB respectively. From D a straight line is drawn perpendicular to BC, and from E another straight line is drawn perpendicular to CA, meeting the former line in O. Show that OF is perpendicular to AB.

PROPOSITION 13. THEOREM.

The angles which one straight line makes with another on one side of it are together equal to two right angles.

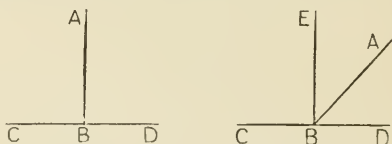

Let AB make with CD on one side of it, \angle s ABC, ABD. It is required to prove

\angle ABC and \angle ABD together = two rt. \angle s.

1. **Proof.** If \angle ABC = \angle ABD,

each of them is a rt. \angle ; *Def. of rt. \angle .*

\therefore \angle ABC and \angle ABD together = two rt. \angle s.

2. **Construction.** If \angle ABC be not = \angle ABD,

from B draw BE \perp CD. *Prop. 11.*

Proof. Then \angle s EBC, EBD are two rt. \angle s. *Constr.*

But \angle ABC and \angle ABD together

coincide with \angle EBC and \angle EBD together; *Ax. 8.*

\therefore \angle ABC and \angle ABD together = two rt. \angle s. *Ax. 1.*

Corollary. The sum of two angles which are supplementary is two right angles.

EXERCISES.

1. If two straight lines intersect, the four angles which they make at the point where they cut are together equal to four right angles.
2. All the successive angles made by any number of straight lines meeting at one point are together equal to four right angles.
3. Two straight lines cannot have a common segment.
4. The angles ABC and ABD , which are made by the straight line AB standing on the straight line CD , are bisected by the straight lines BE and BF . Show that the angle EBF is a right angle.
5. If the two exterior angles formed by producing a side of a triangle both ways are equal, show that the triangle is isosceles.
6. Show that the angles of a triangle formed by a diagonal and two of the sides of a square, together equal two right angles.
7. Construct an angle equal to half a right angle.
8. Make an isosceles triangle having each of its base angles equal to half a right angle, and each of the equal sides equal to a given straight line.
9. If one of the four angles which two intersecting straight lines make with each other be a right angle, all the others are right angles.

PROPOSITION 14. THEOREM.

If at a point in a straight line, two other straight lines on opposite sides of it make the adjacent angles together equal to two right angles, these two straight lines shall be in one and the same straight line.

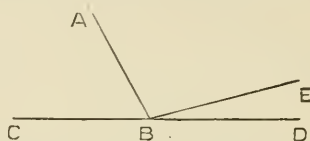

At the point B in AB, let BC and BD, on opposite sides of AB, make $\angle ABC$ and $\angle ABD$ together = two rt. \angle s. It is required to prove BD in the same st. line with BC.

Construction. If BD be not in the same st. line with BC, produce CB to E. *Post. 2.*

Then BE does not coincide with BD.

Proof. Now, \because CBE is a straight line,

$\angle ABC$ and $\angle ABE$ together = two rt. \angle s. *Prop. 13.*

But $\angle ABC$ and $\angle ABD$ together = two rt. \angle s. *Hyp.*

$\therefore \angle ABC$ and $\angle ABE$ together

= $\angle ABC$ and $\angle ABD$ together. *Ax. 1.*

Take away from these equals, $\angle ABC$, which is common.

\therefore the part $\angle ABE$ = the whole $\angle ABD$,

which is impossible. *Ax. 9.*

\therefore BE must coincide with BD ;

that is, BD is in the same st. line with BC.

QUESTIONS ON PROPOSITION 14.

1. What relation does Prop. 14 bear to Prop. 13?
2. Show the necessity of the words 'on opposite sides' in the enunciation.

When two straight lines intersect, the opposite angles are called vertically opposite angles.

PROPOSITION 15. THEOREM.

If two straight lines cut one another, the vertically opposite angles shall be equal.

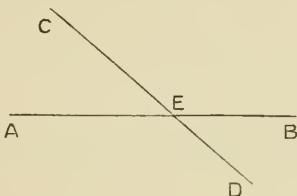

Let AB and CD cut one another at E.

It is required to prove $\angle AEC = \angle BED$,
and $\angle BEC = \angle AED$.

Proof. \because CE meets AB,

$\therefore \angle AEC$ and $\angle BEC$ together = two rt. \angle s. *Prop. 13.*

\because BE meets CD,

$\therefore \angle BEC$ and $\angle BED$ together = two rt. \angle s. *Prop. 13.*

$\therefore \angle AEC$ and $\angle BEC$ together

= $\angle BEC$ and $\angle BED$ together. *Ax. 1.*

Take away from these equals $\angle BEC$, which is common.

$\therefore \angle AEC = \angle BED$. *Ax. 3.*

Similarly, $\angle BEC = \angle AED$.

EXERCISES.

1. If four straight lines meet at a point so that the opposite angles are equal, these straight lines are two and two in the same straight line.
2. What relation does the above theorem bear to Prop. 15?
3. Show that the bisectors of either pair of vertically opposite angles in Prop. 15, are in the same straight line.
4. Show that, if AB is perpendicular to the straight line CD, which it meets at B, and if AB is produced to E, BE is also perpendicular to CD.
5. From two given points on the same side of a given straight line, show how to draw two straight lines which shall meet at a point in the given straight line and make equal angles with it.
6. If the diagonals of a quadrilateral bisect one another, show that the opposite sides are equal.
7. In the figure of Prop. 15, make EB equal to ED, and EC equal to EA, and join AD, DB and BC. Then prove the angle AED equal to the angle CED, without assuming any proposition after Prop. 5.
8. The side AC of the triangle ABC is bisected at E, and BE is drawn and produced to F, making EF equal to EB.

Show that :

$$(a) FC = AB.$$

$$(b) \angle FCE = \angle BAE.$$

PROPOSITION 16. THEOREM.

If one side of a triangle be produced, the exterior angle shall be greater than either of the interior opposite angles.

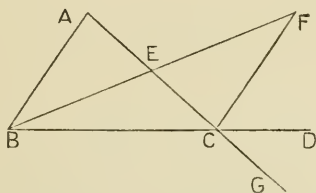

Let ABC be a triangle, and let BC be produced to D .
It is required to prove $\angle ACD$ greater than $\angle BAC$, and also greater than $\angle ABC$.

Construction. Bisect AC at E . *Prop. 10*

Join BE , produce it to F , and make $EF = EB$. *Prop. 3.*

Join CF .

Proof. In Δs AEB and CEF ,

$AE = CE$, *Constr.*

$EB = EF$, *Constr.*

and included $\angle AEB =$ included $\angle CEF$,

being vertically opposite $\angle s$, *Prop. 15.*

$\therefore \angle EAB = \angle ECF$. *Prop. 4.*

But $\angle ACD$ is greater than $\angle ECF$; *Ax. 9.*

$\therefore \angle ACD$ is greater than $\angle EAB$, that is, $\angle BAC$.

Similarly, if AC be produced to G ,

it may be shown that $\angle BCG$ is greater than $\angle ABC$.

But $\angle ACD =$ vertically opposite $\angle BCG$; *Prop. 15.*

$\therefore \angle ACD$ is greater than $\angle ABC$.

PROPOSITION 17. THEOREM.

Any two angles of a triangle are together less than two right angles.

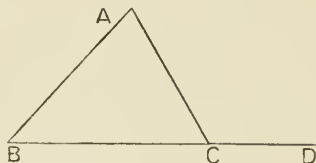

Let ABC be a triangle.

It is required to prove the sum of any two of its angles less than two rt. angles.

Construction. Produce BC to D.

Proof. Then int. \angle ABC is less than ext. \angle ACD. *Prop.* 16.
 $\therefore \angle$ ABC and \angle ACB are together less than \angle ACD and \angle ACB together.

But \angle ACD and \angle ACB together = two rt. \angle s. *Prop.* 13.
 $\therefore \angle$ ABC and \angle ACB are together less than two rt. \angle s.
 Similarly it may be shown that \angle s BCA, CAB are together less than two rt. \angle s, and \angle s CAB, ABC are together less than two rt. \angle s.

QUESTIONS ON PROPOSITION 17.

1. Show that the proposition can be proved by joining the vertex to a point in the opposite side.
2. State Axiom 12.
3. Enunciate Prop. 17 and Axiom 12, so as to show that they are converse theorems.

EXERCISES.

1. A is a given point and BC a given straight line.
 - (a) Find a point in BC, whose distance from A is equal to the length of another straight line DE.
 - (b) Show that two, and not more than two, such straight lines can be drawn.
 - (c) Show that only one perpendicular can be drawn from A to BC.
2. P is any point within the triangle ABC, and PA and PB are joined. Show that the angle APB is greater than the angle ACB.
3. Show that two angles of every triangle must be acute angles.
4. Show that two exterior angles of every triangle must be obtuse angles. Of what triangle will the three exterior angles be obtuse?
5. In the figure of Prop. 16, show that the area of the triangle ABC is equal to the area of the triangle FBC.

PROPOSITION 18. THEOREM.

If one side of a triangle be greater than a second side, the angle opposite the first side shall be greater than the angle opposite the second.

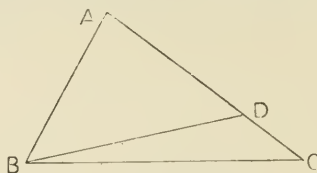

Let ABC be a triangle, having AC greater than AB . It is required to prove $\angle ABC$ greater than $\angle ACB$.

Construction. From AC cut off $AD = AB$, *Prop. 3.*
and join BD .

Proof. $\therefore \angle ADB$ is an exterior angle of $\triangle BCD$,
 $\therefore \angle ADB$ is greater than $\angle ACB$. *Prop. 16.*
But $\because AB = AD$, $\therefore \angle ADB = \angle ABD$; *Prop. 5.*
and $\therefore \angle ABD$ is greater than $\angle ACB$.

Much more then is $\angle ABC$ greater than $\angle ACB$.

QUESTIONS ON PROPOSITION 18.

1. State the hypothesis and the conclusion of Prop. 18.
2. Is Prop. 18 equivalent to the theorem, "the greatest side of a triangle has the greatest angle opposite to it"?

EXERCISES.

1. Prove Prop. 18 by producing the shorter side.
2. $ABCD$ is a quadrilateral of which AD is the longest side, and BC the shortest; show that the angle ABC is greater than the angle ADC , and the angle BCD greater than the angle BAD .
3. Show that the hypotenuse of a right-angled triangle is the greatest side of the triangle.

PROPOSITION 19. THEOREM.

If one angle of a triangle be greater than a second angle, the side opposite the first angle shall be greater than the side opposite the second.

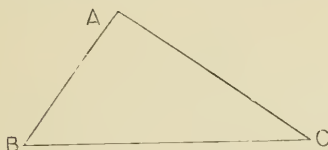

Let ABC be a triangle having $\angle ABC$ greater than $\angle ACB$.
It is required to prove AC greater than AB .

Proof. If AC be not greater than AB ,
then AC must $= AB$, or be less than AB .

If AC were $= AB$,
then would $\angle ABC = \angle ACB$. *Prop. 5.*

But it is not. *Hyp.*

$\therefore AC$ is not $= AB$.

If AC were less than AB ,
then $\angle ABC$ would be less than $\angle ACB$. *Prop. 18.*

But it is not. *Hyp.*

$\therefore AC$ is not less than AB .

Hence AC must be greater than AB .

QUESTIONS ON PROPOSITION 19.

1. What is the hypothesis of Prop. 19. What is the conclusion?
2. Enunciate the converse of Prop. 19.
3. Is Prop. 19 equivalent to the theorem "the greatest angle of a triangle has the greatest side opposite to it?"

EXERCISES.

1. In an obtuse-angled triangle the greatest side is opposite the obtuse angle ; and in a right-angled triangle the greatest side is opposite the right angle.
2. Show that three equal straight lines cannot be drawn from a given point to a given straight line.
3. The perpendicular is the shortest line that can be drawn from a given point to a given straight line, and of the others that which is nearer the perpendicular is less than the one more remote.
4. Any straight line drawn from the vertex of an isosceles triangle to a point in the base is less than either of the equal sides.
5. Enunciate and prove a theorem similar to Ex. 4, when the point is taken in the base produced.
6. The vertical angle ABC of the triangle ABC is bisected by the straight line BD , which meets the base in D . Show that AB is greater than AD , and CB is greater than CD .
7. Every straight line drawn from the vertex of a triangle to the base is less than the greater of the two sides, or than either, if they be equal.

PROPOSITION 20. THEOREM.

Any two sides of a triangle are together greater than the third side.

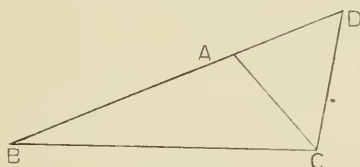

Let ABC be a triangle.

It is required to prove that any two of its sides are together greater than the third side.

Construction. Produce BA to D, making
 $AD = AC,$ *Prop. 3.*
 and join CD.

Proof. Then $\because AD = AC, \therefore \angle ACD = \angle ADC.$ *Prop. 5.*

But $\angle BCD$ is greater than $\angle ACD;$

\therefore in $\triangle BCD, \angle BCD$ is greater than $\angle BDC.$

$\therefore BD$ is greater than $BC.$ *Prop. 19.*

But $\because AC = AD, \therefore BD = BA$ and AC together;

$\therefore BA$ and AC are together greater than $BC.$

Similarly it may be shown that AC and CB are together greater than $AB,$ and AB and BC are together greater than $AC.$

PROPOSITION 21. THEOREM.

If, from the ends of a side of a triangle, there be drawn two straight lines to a point within the triangle, these will be together less than the other sides of the triangle, but will contain a greater angle.

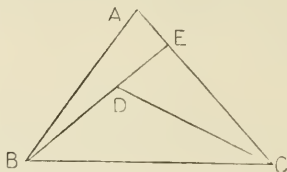

Let ABC be a Δ , and from B and C let BD and CD be drawn to any point D within the Δ .

It is required to prove that BD and DC are together less than BA and AC , but that $\angle BDC$ is greater than $\angle BAC$.

Construction. Produce BD to meet AC in E .

Proof. In ΔBAE , BA and AE are together greater than BE . *Prop.* 20.

Add to each EC .

$\therefore BA$ and AC are together greater than BE and EC .

Again, in ΔDEC , DE and EC are together greater than DC . *Prop.* 20.

Add to each BD .

$\therefore BE$ and EC are together greater than BD and BC .

And it has been shown that BA and AC are together greater than BE and EC ;

$\therefore BA$ and AC are together greater than BD and DC .

Next, because ext. $\angle BDC$ is greater than int. opp. $\angle DEC$, and ext. $\angle DEC$ is greater than int. opp. $\angle BAC$, *Prop.* 16.

$\therefore \angle BDC$ is greater than $\angle BAC$.

EXERCISES.

1. Prove Prop. 20, by bisecting the vertical angle by a straight line which meets the base.
2. Prove Prop. 20, by drawing a perpendicular from the vertex to the base.
3. (a) In the figure of Prop. 16, prove that CF is equal to AB .
(b) Hence prove that the sum of any two sides of a triangle is greater than twice the straight line drawn from the middle point of the third side to the opposite vertex.
4. (a) Prove that the sum of the sides of any quadrilateral is greater than twice either diagonal.
(b) Hence prove that the sum of the sides is greater than the sum of the diagonals.
5. Take any point O , and join to the angular points of the triangle ABC .
(a) Prove that the sum of OA and OB is greater than AB .
(b) Prove that twice the sum of OA , OB and OC is greater than the sum of the sides.
6. If a point be taken within a quadrilateral, and joined to each of the angular points, show that the sum of these joining lines is the least possible, when the point taken is the point of intersection of the diagonals.
7. Four points lie in a plane, no one of them being within the triangle formed by joining the other three. Find the point, the sum of whose distances from these four points is the least possible.
8. A point P is taken within the triangle ABC . Show that the sum of the sides AB and AC is greater than the sum of PB and PC .
9. In any triangle, the difference between any two sides is less than the third side.
10. In the figure of Prop. 21, join DA , and show that the sum of DA , DB and DC is less than the sum of the sides of the triangle ABC , but greater than half the sum.
11. In the figure of Prop. 21, show that the angle BDC is greater than the angle BAC , by joining AD and producing it towards the base.
12. If two triangles have the same base and have equal vertical angles, the vertex of each triangle must lie outside the other.

PROPOSITION 22. PROBLEM.

To make a triangle the sides of which shall be equal to three given straight lines, any two of which are together greater than the third.

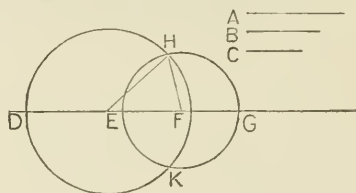

Let A , B , C be the three given st. lines, any two of which are together greater than the third.

It is required to make a triangle the sides of which shall be respectively equal to A , B and C .

Construction. Take a point D in a st. line of unlimited length.

From the line cut off $DE = A$, $EF = B$, $FG = C$. *Prop.* 3.

With centre E and radius ED , describe the \odot DHK .

With centre F and radius FG , describe the \odot GHK , cutting the other \odot at H .

Join HE , HF .

HEF is the \triangle required.

Proof. $\therefore EH = ED$, being radii of \odot DHK , *Def. of \odot .*

$\therefore EH = A$.

$\therefore FH = FG$, being radii of \odot GHK , *Def. of \odot .*

$\therefore FH = C$.

And EF was made $= B$.

$\therefore \triangle HEF$ has its sides respectively equal to A , B and C .

QUESTIONS ON PROPOSITION 22.

1. Why does the enunciation state that any two of the given lines are together greater than the third?
2. Will the circumferences of two circles intersect, if the sum of their radii is greater than the distances between their centres?

PROPOSITION 23. PROBLEM.

At a given point in a given straight line, to make an angle equal to a given angle.

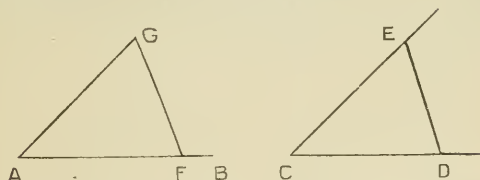

Let AB be the given straight line, A the given point in it, and $\angle DCE$ the given angle.

It is required to make at A an angle = $\angle DCE$.

Construction. In CD, CE take any points D, E.

Join DE.

Make $\triangle AFG$, such that $AF = CD$, $FG = DE$,
and $AG = CE$.

Prop. 22.

FAG is the \angle required.

Proof. In \triangle s AFG and CDE,

$$AF = CD,$$

$$AG = CE,$$

and base $FG =$ base DE ,

$$\therefore \angle FAG = \angle DCE. \quad \text{Prop. 8.}$$

EXERCISES.

1. Prove Prop. 23, giving all the construction, instead of assuming Prop. 22.
2. Construct a triangle, having given two sides and the angle between them.
3. Construct a triangle, having given the base, and having the angles adjacent to the base equal to two given angles.
Is this always possible?
4. Construct a right-angled triangle, having given the hypotenuse and one side.
5. Construct a quadrilateral equal in all respects to a given quadrilateral.

PROPOSITION 24. THEOREM.

If two triangles have two sides of the one equal to two sides of the other, each to each, but the included angles unequal, the base of the triangle which has the greater included angle shall be greater than the base of the other.

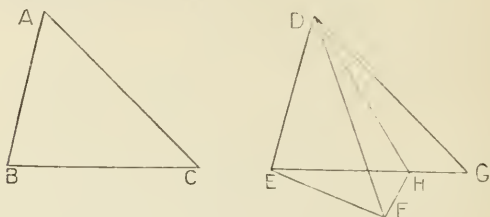

Let ABC , DEF be two triangles, having $AB = DE$,
 $AC = DF$, but $\angle BAC$ greater than $\angle EDF$.

It is required to prove BC greater than EF .

Construction. At D in st. line DE make $\angle EDG = \angle BAC$.

Prop. 23.

Cut off $DG = AC$ or DF , and join EG . *Prop. 3.*

If F lies on EG , then EG is greater than EF .

If F does not lie on EG ,

bisect $\angle FDG$ by DH , meeting EG at H . *Prop. 9.*

Join FH .

Proof. In Δs ABC and DEG ,

$AB = DE$, *Hyp.*

$AC = DG$, *Constr.*

and included $\angle BAC =$ included $\angle EDG$, *Constr.*

$\therefore BC = EG$. *Prop. 4.*

Again in Δs FDH and GDH ,

$DF = DG$, *Constr.*

$DH = DH$,

and included $\angle FDH =$ included $\angle GDH$, *Constr.*

$\therefore FH = GH$. *Prop. 4.*

$\therefore EH$ and FH together = EH and GH together = EG .
 But EH and FH are together greater than EF ; *Prop. 20.*

$\therefore EG$ is greater than EF ;

\therefore in either case, BC is greater than EF .

PROPOSITION 25. THEOREM.

If two triangles have two sides of the one equal to two sides of the other, each to each, but their bases unequal, the angle contained by the two sides of the triangle which has the greater base shall be greater than the angle contained by the two sides of the other.

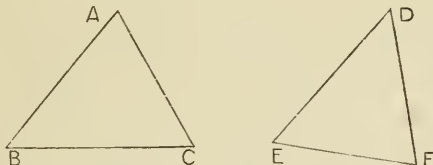

Let ABC , DEF be two Δ s, of which $AB = DE$,
 $AC = DF$, but base BC is greater than base EF .

It is required to prove $\angle BAC$ greater than $\angle EDF$.

Proof. If $\angle BAC$ be not greater than $\angle EDF$,
it must either $= \angle EDF$ or be less than it.

If $\angle BAC$ were $= \angle EDF$,

then base BC would $=$ base EF . *Prop. 4.*

But it is not. *Hyp.*

$\therefore \angle BAC$ is not $= \angle EDF$.

If $\angle BAC$ were less than $\angle EDF$,

then base BC would be less than base EF . *Prop. 24.*

But it is not. *Hyp.*

$\therefore \angle BAC$ is not less than $\angle EDF$.

$\therefore \angle BAC$ must be greater than $\angle EDF$.

EXERCISES.

1. Show that Prop. 24 and Prop. 25 are converse propositions.
2. Assuming the truth of Prop. 25, deduce the truth of Prop. 24.
3. D is the middle point of the side BC of the triangle ABC . Prove that the angle ADB is greater or less than the angle ADC , according as AB is greater or less than AC .
4. State and prove the converse of the preceding theorem.

PROPOSITION 26. THEOREM.

If two triangles have two angles of the one equal to two angles of the other, each to each, and one side equal to one side, namely, either the sides adjacent to the equal angles, or the sides opposite to equal angles in each; then shall the triangles be equal in all respects.

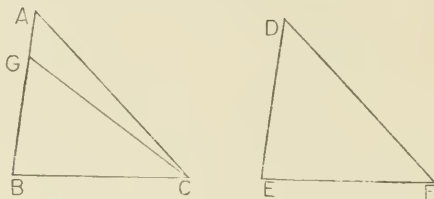

In Δ s ABC and DEF,

let $\angle ABC = \angle DEF$, and $\angle ACB = \angle DFE$, and first let the adjacent sides be equal, that is, let $BC = EF$.

It is required to prove that $AB = DE$, $AC = DF$, and $\angle BAC = \angle EDF$.

Construction. For if AB be not $= DE$, let AB be the greater, and make $GB = DE$, and join GC .

Proof. Then in Δ s GBC and DEF,

$$GB = DE,$$

$$BC = EF,$$

and included $\angle GBC =$ included $\angle DEF$,

$$\therefore \angle GCB = \angle DFE.$$

Prop. 4.

$$\text{But } \angle ACB = \angle DFE,$$

Hyp.

$$\therefore \text{part } \angle GCB = \text{whole } \angle ACB;$$

which is impossible.

$\therefore AB$ is not greater than DE .

Similarly it may be shown that AB is not less than DE .

$$\therefore AB = DE.$$

Then in Δ s ABC and DEF,

$AB = DE$, $BC = EF$, and included $\angle ABC =$ included $\angle DEF$,

$$\therefore AC = DF, \text{ and } \angle BAC = \angle EDF. \quad \text{Prop. 4.}$$

Next, let the sides opposite to equal angles be equal, that is, let $AB = DE$.

It is required to prove that $AC = DF$, $BC = EF$, and $\angle BAC = \angle EDF$.

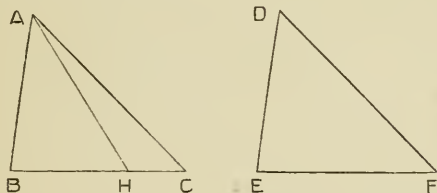

Construction. For if BC be not equal to EF , let BC be the greater, and make $BH = EF$, and join AH .

Proof. Then in Δ s ABH and DEF ,

$$AB = DE,$$

$$BH = EF,$$

and included $\angle ABH =$ included $\angle DEF$,

$$\therefore \angle AHB = \angle DFE. \quad \text{Prop. 4.}$$

But $\angle ACB = \angle DFE$, *Hyp.*

$$\therefore \angle AHB = \angle ACB;$$

that is, in ΔAHC , ext. $\angle AHB =$ int. opp. $\angle ACB$,

which is impossible. *Prop. 16.*

$\therefore BC$ is not greater than EF .

Similarly it may be shown that BC is not less than EF .

$$\therefore BC = EF.$$

Then in Δ s ABC and DEF ,

$\therefore AB = DE$, $BC = EF$, and included $\angle ABC =$ included $\angle DEF$,

$$\therefore AC = DF, \text{ and } \angle BAC = \angle EDF. \quad \text{Prop. 4.}$$

EXERCISES.

1. The angle BAC is bisected by the line AD. From D the lines DB and DC are drawn making the angles ADB and ADC equal. Prove that DB, DC are equal.
2. The bisector AD of the angle BAC of the triangle ABC meets BC in D. Prove that if the angles ADB, ADC are equal, the triangle is isosceles.
3. The equal angles of an isosceles triangle ABC are bisected by the lines BD, CE, which meet the opposite sides in D and E respectively ; prove that BD and CE are equal.
4. Any point in the bisector of an angle is equidistant from the arms of the angle.
5. Find the point in the base of a triangle which is equidistant from the sides.
6. Prove Prop. 26 by superposition.
7. If two sides of a triangle be produced, prove that the two bisectors of the angles so formed meet at a point equidistant from the three sides of the triangle.

EXERCISES ON PROPOSITIONS 1-24.

1. The vertical angle BAC of an isosceles triangle ABC is bisected by AD. If any point E be taken in AD, prove that EB equals EC.
2. ABC is a triangle such that AB equals AC. A line CD is drawn to cut AB in D ; the point E is taken in AC such that AE equals AD. Prove that the angle AEB is equal to the angle ADC.
3. If the opposite sides of a quadrilateral are equal, the opposite angles are equal.
4. AB is a given straight line and C is a given point ; draw through A and C a straight line AD whose length is four times AB.
5. Describe an equilateral triangle having a given point A for the middle point of one side, and having each of the sides equal in length to a given straight line BC.
6. In a given circle BCD place a straight line BC equal to the straight line AE, and having its extremities B and C in the circumference. Is this always possible ?

7. Upon the base BC describe a triangle such that the perpendicular from the vertex on the base equals a given straight line EF, and cuts the base in D.
8. Describe a quadrilateral having given the length of each side, and of one diagonal.
9. Construct a quadrilateral having each of its sides equal to a given straight line, and having one of its angles equal to a given angle.
10. If the diagonals of a quadrilateral bisect each other, the opposite sides and angles are equal.
11. Any three sides of a quadrilateral are together greater than the fourth side.
12. If a quadrilateral has four equal sides and equal diagonals, and one angle a right angle, it is a square.
13. If two right angled triangles have equal hypotenuses, and a side of one equal to the side of the other, they are equal in every respect.
14. AB, AC are the equal sides of an isosceles triangle; BD and CD are drawn perpendicular respectively to AB and AC to meet in D. Prove that BD equals CD, and that AD bisects the angle BAC.
15. ABC is a triangle, BC is the base, and AC is greater than AB. A is joined to D, the middle point, of BC. Prove that the angle ADC is obtuse.
16. If E is any point in AD, of Ex. 15, and E be joined to B and C, prove that EB is less than EC.
17. P is any point in the plane of the angle BAC; show how to draw through P a straight line, which will make an isosceles triangle with the arms of the angle BAC.
18. The base of a triangle is produced both ways, and the exterior angles are bisected. Prove that the point of intersection of these lines is equidistant from the sides of the triangle; also, that the line joining this point of intersection to the opposite angle of the triangle bisects the angle.
19. If one side of a triangle be less than another, the angle opposite the less side must be acute.

20. Prove that the sum of the perpendiculars, drawn from the vertices of a triangle to the opposite sides, is less than the perimeter of the triangle.
21. Prove that the sum of the three lines joining the middle points of the three sides of a triangle to the opposite vertices is less than the perimeter of the triangle.
22. In any triangle ABC , D is any point in the base BC . Prove that AD is less than the greater of the two sides, AB and AC .
23. Two sides, AB and AC , of the triangle ABC , are produced to D and E respectively, and the angle DBC is equal to the angle ECB . Show that AB is equal to AC .
24. E is the point of intersection of the diagonals of the square $ABCD$. F is the middle point of AB , and G the middle point of BC . EF is produced, making FH equal to EF ; and EG is produced, making GK equal to EG . Show that H , B and K lie in the same straight line.

When one straight line cuts two other straight lines it makes with them eight angles, to which, for the sake of clearness, particular names are given.

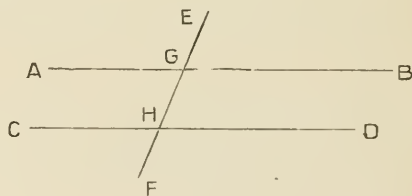

If the straight line EF cuts the two straight lines AB and CD at the points G and H ,

EGA , EGB , FHC , FHD are called **exterior** angles ;

AGH , BGH , GHC , GHD are called **interior** angles ;

AGH , GHD , are called **alternate** angles ;

BGH , GHC are also called **alternate** angles ;

EGB , GHD are an exterior angle and an interior opposite angle on the same side of the straight line EF .

PROPOSITION 27. THEOREM.

If a straight line, cutting two other straight lines, make the alternate angles equal, then the two straight lines shall be parallel.

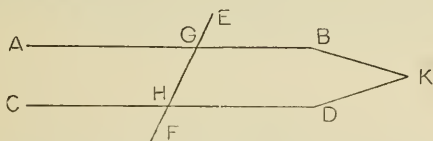

Let the st. line EF , cutting the two st. lines AB and CD , at G and H respectively, make the alternate \angle s AGH , GHD equal.

It is required to prove $AB \parallel CD$.

Construction. If AB is not $\parallel CD$, these lines must meet, when produced, either towards A and C , or towards B and D . If possible, let them meet when produced towards B and D , in K .

Proof. Then $\triangle GHK$ is a Δ ,

\therefore ext. $\angle AGH$ is greater than int. opp. $\angle GHK$. *Prop. 16.*

But $\angle AGH = \angle GHK$; *Hyp.*

that is, $\angle AGH$ is both greater than and $= \angle GHK$,
which is impossible.

\therefore AB and CD do not meet when produced towards B and D . Similarly it may be shown that they do not meet when produced towards A and C .

$\therefore AB \parallel CD$. *Def. of parl. lines.*

PROPOSITION 28. THEOREM.

If a straight line, cutting two other straight lines, make the exterior angle equal to the interior opposite angle on the same side of the line, or make the interior angles on the same side together equal to two right angles, the two straight lines shall be parallel.

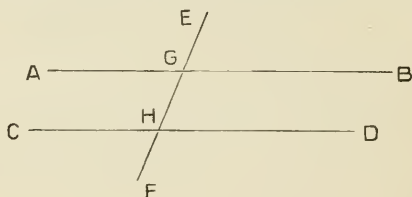

Let the st. line EF , cutting the st. lines AB and CD , at G and H respectively, make

(1) ext. $\angle EGB =$ int. opp. $\angle GHD$,

or, (2) int. \angle s BGH, GHD together = two right \angle s.

It is required to prove $AB \parallel CD$.

Proof. (1) $\therefore \angle EGB =$ vertically opp. $\angle AGH$, *Prop. 15.*
and $\angle EGB = \angle GHD$, *Hyp.*
 $\therefore \angle AGH =$ alternate $\angle GHD$.

$\therefore AB \parallel CD$. *Prop. 27.*

(2) $\therefore \angle$ s BGH, GHD together = two rt. \angle s, *Hyp.*
and \angle s BGH, AGH together = two rt. \angle s, *Prop. 13.*
 \angle s BGH, AGH together = \angle s BGH, GHD together.

$\therefore \angle AGH =$ alternate $\angle GHD$.

$\therefore AB \parallel CD$. *Prop. 27.*

EXERCISES.

1. The opposite sides of a square are parallel.
2. Prove that in the figure of Prop. 16, the lines AB and FC are parallel.
3. Prove that a rhombus is a parallelogram.
4. If the diagonals of a quadrilateral bisect each other, show that the quadrilateral is a parallelogram.
5. Show that straight lines which are perpendicular to the same straight line are parallel.
6. Prove that no two straight lines drawn from two angles of a triangle and terminated by the opposite sides, or those sides produced, can bisect each other.
7. Two straight lines bisect each other. Show that a parallelogram is formed by joining their extremities.

PROPOSITION 29. THEOREM.

If a straight line cut two parallel straight lines, it shall make the alternate angles equal to one another, the exterior angle equal to the interior opposite angle on the same side of the line, and the two interior angles on the same side together equal to two right angles.

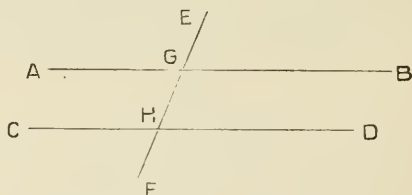

Let the st. line EF cut the two parl. st. lines AB , CD , at G and H respectively.

It is required to prove—

- (1) $\angle AGH =$ alternate $\angle GHD$,
- (2) ext. $\angle EGB =$ int. opp. $\angle GHD$,
- (3) two int. \angle s BGH , GHD together = two rt. \angle s.

Proof (1) If $\angle AGH$ be not = $\angle GHD$,
one of them must be the greater.

Suppose $\angle AGH$ greater than $\angle GHD$.

Add to each, $\angle BGH$.

Then \angle s AGH , BGH together will be greater than \angle s BGH , GHD together.

But \angle s AGH , BGH together = two rt. \angle s *Prop. 13*.
 $\therefore \angle$ s BGH , GHD together will be less than two rt. \angle s.

And $\therefore AB$ and CD will meet when produced
towards B and D . *Ax. 12.*

But AB and CD do not meet, since they are parl. *Hyp.*

\therefore must $\angle AGH =$ alternate $\angle GHD$.

(2) Again, $\therefore \angle AGH =$ alternate $\angle GHD$,
 and $\angle AGH =$ vertically opp. $\angle EGB$. *Prop.* 15.
 \therefore ext. $\angle EGB =$ int. opp. $\angle GHD$.

(3) And again $\angle EGB = \angle GHD$.

Add to each, $\angle BGH$.

$\therefore \angle$ s EGB, BGH together $= \angle$ s BGH, GHD together.

But \angle s EGB, BGH together $=$ two rt. \angle s. *Prop.* 13.

\therefore int. \angle s BGH, GHD together $=$ two rt. \angle s.

PROPOSITION 30. THEOREM.

Straight lines which are parallel to the same straight line are parallel to one another.

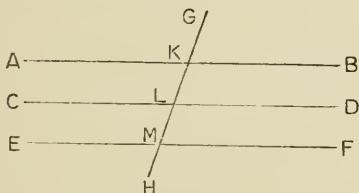

Let the st. lines AB and CD be each $\parallel EF$.

It is required to prove $AB \parallel CD$.

Construction. Draw the st. line GH cutting AB, CD, EF in K, L, M respectively.

Proof. $\therefore AB \parallel EF$,

\therefore ext. $\angle GKB =$ int. opp. $\angle LMF$. *Prop.* 29.

And $\therefore CD \parallel EF$,

\therefore ext. $\angle KLD =$ int. opp. $\angle LMF$. *Prop.* 29.

And \therefore ext. $\angle GKB =$ int. opp. $\angle KLD$.

$\therefore AB \parallel CD$. *Prop.* 28.

EXERCISES.

1. A straight line parallel to the base of an isosceles triangle makes equal angles with the sides.
2. Show that a parallelogram which has one angle a right angle is a rectangle.
3. If two straight lines are parallel to two other straight lines, each to each, then the angle contained by the first pair is equal to the angle contained by the second pair.
4. A straight line drawn through the vertex of an isosceles triangle, parallel to the base, bisects the exterior angle at the vertex.
5. Enunciate and prove the converse of the theorem in Ex. 4.
6. Two intersecting straight lines cannot both be parallel to the same straight line.
7. A straight line is drawn terminated by two parallel straight lines : through its middle point any straight line is drawn and terminated by the parallel straight lines. Show that the second straight line is bisected at the middle point of the first.

PROPOSITION 31. PROBLEM.

To draw a straight line through a given point parallel to a given straight line.

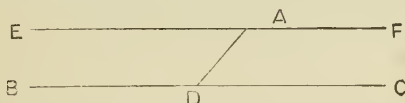

Let A be the given pt. and BC the given st. line.

It is required to draw through A a st. line \parallel BC.

Construction. In BC take any pt. D, and join AD.

At the pt. A in AD, and on the side of it, opposite

to C, make $\angle DAE = \angle ADC$. *Prop. 23.*

Produce EA to F.

EF shall be the required line.

Proof. $\therefore \angle EAD =$ alternate $\angle ADC$,

$\therefore EF \parallel BC$, *Prop. 27.*

and EF is drawn through the given pt. A.

EXERCISES.

1. From a point D in the base BC of an isosceles triangle ABC, straight lines DE and DF are drawn parallel to the equal sides. Show that the sum of DE and DF is constant.
2. If, in above, D is taken in the base produced, show that the difference of DE and DF is constant.

PROPOSITION 32. THEOREM.

If a side of a triangle be produced, the exterior angle is equal to the sum of the two interior opposite angles, and the three interior angles of every triangle are together equal to two right angles.

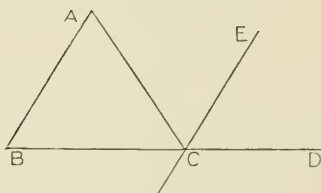

Let the side BC of $\triangle ABC$ be produced to D.

It is required to prove

- (1) ext. $\angle ACD =$ int. opp. \angle s CAB, ABC together,
- (2) \angle s ABC, CAB, BCA together = two rt. \angle s.

Construction. Through the pt. C draw CE \parallel AB. *Prop.* 31.

Proof. (1) \because AC meets the parl. st. lines AB, EC,
 $\therefore \angle ECA =$ alternate \angle CAB. *Prop.* 29.

And \because DB meets the parl. st. lines AB, EC,
 \therefore ext. $\angle ECD =$ int. opp. \angle ABC. *Prop.* 29.

$\therefore \angle$ s ECD, ECA together = \angle s ABC, CAB together.

That is, ext. $\angle ACD =$ int. opp. \angle s ABC, CAB together.

(2) To each of these equals add \angle BCA.

$\therefore \angle$ s ABC, CAB, BCA together = \angle s ACD, ACB together.

But \angle s ACD, ACB together = two rt. \angle s. *Prop.* 13.

$\therefore \angle$ s ABC, CAB, BCA together = two rt. \angle s.

Corollary. All the interior angles of any rectilineal figure together with four right angles, are equal to twice as many right angles as the figure has sides.



Take any point within the figure, and join it to each of the angular points. Then the figure is divided into as many triangles as the figure has sides.

\therefore all the angles of all the triangles = twice as many right angles as the figure has sides. *Prop. 32.*

But all the angles of all the triangles = all the interior angles of the figure, together with the angles at the point taken within the figure; and these angles at the point together = four right angles.

\therefore all the interior angles of the figure together with four right angles = twice as many right angles as the figure has sides.

EXERCISES.

1. Prove that all the exterior angles of a convex rectilineal figure are together equal to four right angles.
2. Show that, if one angle of a triangle is equal to the sum of the other two angles, the triangle is right-angled.
3. Prove that each angle of an equilateral triangle is two-thirds of a right angle.
4. Divide a right angle into three equal parts.
5. Show that each angle of an equiangular hexagon is double of each angle of an equilateral triangle.
6. If from B, the middle point of a straight line AC, a straight line BD equal to AB be drawn, and AD and CD be also joined, the triangle ACD will be right-angled.
7. Draw a straight line, at right angles to a given straight line, from one of its extremities, without producing the line.
8. Each of the angles of an equiangular polygon is six-fifths of a right angle. Show that the polygon has five sides.

PROPOSITION 33. THEOREM.

The straight lines which join the extremities of two equal and parallel straight lines, towards the same parts, are themselves equal and parallel.

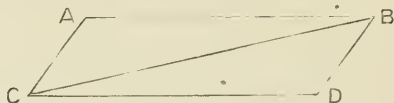

Let the extremities of the two equal and parl. st. lines, AB and CD, be joined towards the same parts, by the st. lines AC, BD.

It is required to prove $AC = BD$, and $AC \parallel BD$.

Construction. Join BC.

Proof. $\because AB \parallel CD$,

$\therefore \angle ABC = \text{alternate } \angle BCD.$ *Prop. 29.*

In Δ s ABC, DCB,

$AB = DC$,

$BC = CB$,

and included $\angle ABC = \text{included } \angle DCB$,

$\therefore AC = BD$,

and $\angle ACB = \angle DBC.$ *Prop. 4.*

And $\because BC$ meets the st. lines AC and BD,
and makes the $\angle ACB = \text{alternate } \angle DBC$.

$\therefore AC \parallel BD.$ *Prop. 27.*

EXERCISES.

1. The straight lines which join the extremities of two equal and parallel straight lines towards opposite parts, bisect each other.
2. If the diagonals of a quadrilateral bisect each other the quadrilateral is a parallelogram.
3. The perpendiculars drawn from two points A, B to the straight line CD are equal. Show that CD is either parallel to AB or bisects AB.

PROPOSITION 34. THEOREM.

The opposite sides and angles of a parallelogram are equal, and each diagonal bisects the parallelogram.



Let ABCD be a $\parallel m$, of which BD is a diagonal.

It is required to prove $AB = DC$, $AD = BC$, $\angle BAD = \angle BCD$, $\angle ABC = \angle ADC$, and $\triangle ABD = \triangle CBD$.

Proof. $\because AB \parallel DC$,

$\therefore \angle ABD = \text{alternate } \angle CDB.$ *Prop. 29.*

And $\because AD \parallel BC$,

$\therefore \angle ADB = \text{alternate } \angle CBD.$ *Prop. 29.*

Then, in $\triangle s$ ABD, CDB,

$\angle ABD = \angle CDB$,

$\angle ADB = \angle CBD$

and $BD = DB$,

$\therefore AB = CD$,

$AD = BC$,

$\angle BAD = \angle BCD$,

and $\triangle ABD = \triangle CBD.$

Prop. 26.

Also, since the parts are equal, each to each, the whole $\angle ABC = \text{the whole } \angle ADC$.

EXERCISES.

1. If both pairs of opposite sides of a quadrilateral are equal, show that it is a parallelogram.
2. If both pairs of opposite angles of a quadrilateral are equal, show that it is a parallelogram.
3. Draw a straight line through a given point such that the part of it intercepted between two given parallel straight lines may be equal to a given straight line.
4. The straight line drawn through the point of bisection of a diagonal of a parallelogram and terminated by two opposite sides, bisects the parallelogram.
5. Through a given point, draw a straight line which shall bisect a given parallelogram.

NOTE.—Sometimes it is convenient to denote the same point by two letters, such as the point D, or the point E, in the first figure of proposition 35.

PROPOSITION 35. THEOREM.

Parallelograms on the same base and between the same parallels are equal.

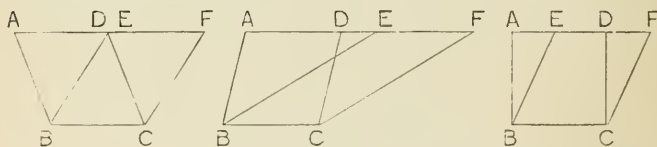

Let the \parallel ms ABCD, EBCF, be on the same base BC, and between the same \parallel s, AF, BC.

It is required to prove \parallel m ABCD = \parallel m EBCF.

Proof. \because AB \parallel DC, and FA meets them,

\therefore int. \angle EAB = ext. \angle FDC. *Prop. 29.*

And \because EB \parallel FC, and FA meets them,

\therefore ext. \angle AEB = int. \angle EFC.

And \because ABCD is a \parallel m,

\therefore side AB = opp. side DC. *Prop. 34.*

Hence in Δ s EAB, FDC,

\angle EAB = \angle FDC,

\angle AEB = \angle DFC,

and AB = DC.

\therefore Δ EAB = Δ FDC. *Prop. 26.*

\therefore remainder after taking Δ EAB from figure ABCF

= remainder after taking Δ FDC from figure ABCF.

\therefore \parallel m EBCF = \parallel m ABCD.

PROPOSITION 36. THEOREM.

Parallelograms on equal bases and between the same parallels are equal.

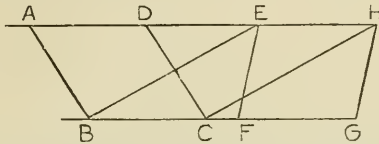

Let the \parallel ms ABCD, EFGH be on equal bases, BC and FG, and between the same \parallel s, AH and BG.

It is required to prove

$$\parallel m ABCD = \parallel m EFGH.$$

Construction. Join BE and CH.

Proof. \because BC = FG,
and EH = opposite side FG, *Prop. 34.*

$$\therefore BC = EH$$

Also, BC \parallel EH,

\therefore BE \parallel CH, *Prop. 33.*

and EBCH is a \parallel m.

Now, \parallel ms ABCD, EBCH are on same base BC and between the same \parallel s.

$$\therefore \parallel m ABCD = \parallel m EBCH.$$

And \parallel ms EFGH, EBCH, *Prop. 35.*
are on same base EH, and between the same \parallel s.

$$\therefore \parallel m EFGH = \parallel m EBCH.$$

$$\therefore \parallel m ABCD = \parallel m EFGH.$$

EXERCISES.

1. Make a rectangle equal to a given parallelogram.
2. Make a parallelogram equal to one parallelogram and having its angles respectively equal to the angles of another parallelogram.
3. Make a rhombus equal to a given parallelogram.
4. Make a parallelogram equal to one parallelogram and having its sides respectively equal to the sides of another parallelogram.

Altitude. The altitude of a triangle, with reference to a given side as base, is the perpendicular drawn to the base from the opposite vertex. The altitude of a parallelogram, with reference to a particular side as base, is the perpendicular drawn to the base from a point in the opposite side.

PROPOSITION 37. THEOREM.

Triangles on the same base and between the same parallels are equal.

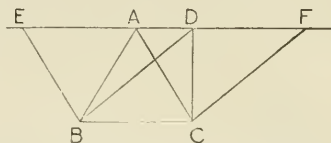

Let the Δ s ABC, DBC be on the same base BC and between the same \parallel s, BC and AD.

It is required to prove $\Delta ABC = \Delta DBC$.

Construction. Through B draw BE \parallel AC, meeting AD produced in E.

Through C draw CF \parallel BD, meeting AD produced in F.

Proof. \therefore \parallel ms EBCA, DBCF are on the same base BC, and between the same \parallel s, BC and EF.

$\therefore \parallel$ m EBCA = \parallel m DBCF. *Prop. 35.*

But $\Delta ABC =$ one-half of \parallel m EBCA, *Prop. 34.*
and $\Delta DBC =$ one-half of \parallel m DBCF.

$\therefore \Delta ABC = \Delta DBC.$ *Ax. 5.*

PROPOSITION 38. THEOREM.

Triangles on equal bases and between the same parallels are equal.

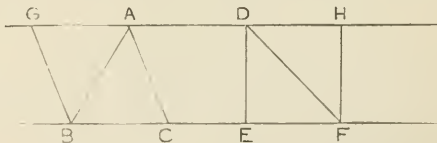

Let the Δ s ABC, DEF be on equal bases, BC and EF, and between the same \parallel s BF and AD.

It is required to prove $\Delta ABC = \Delta DEF$.

Construction. Through B draw BG \parallel AC, meeting AD produced in G.

Through F draw FH \parallel DE, meeting AD produced in H.

Proof. Then \parallel ms GBCA, DEFH are on equal bases, BC and EF, and between the same \parallel s, BF and GH.

$\therefore \parallel$ m GBCA = \parallel m DEFH. *Prop. 36.*

But $\triangle ABC$ = one-half of \parallel m GBCA, *Prop. 34.*

and $\triangle DEF$ = one-half of \parallel m DEFH.

$\therefore \triangle ABC = \triangle DEF.$ *Ax.*

EXERCISES.

1. If two parallelograms have equal altitudes and have also the sides equal, with respect to which the altitudes are drawn, the parallelograms are equal.
2. If two triangles have equal altitudes and equal bases the triangles are equal.
3. The straight line drawn from the vertex of a triangle to the middle point of the base, divides the triangle into two equal parts.
4. Show that a parallelogram is divided by its diagonals into four equal triangles.
5. Make an isosceles triangle equal to a given triangle, and having the same base.
6. Make a triangle equal to a given triangle, having the same base, and having its vertex in a given straight line.

PROPOSITION 39. THEOREM.

Equal triangles on the same base, and on the same side of it, are between the same parallels.

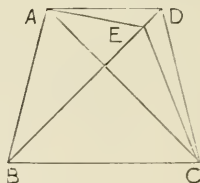

Let Δ s ABC, DBC, on same side of the base BC, be equal.

Join AD.

It is required to prove $AD \parallel BC$.

Construction. If AD is not $\parallel BC$, draw $AE \parallel BC$, meeting BD or BD produced, in E , and join EC .

Proof. $\therefore \Delta$ s ABC, EBC are on same base BC and between same \parallel s,

$$\therefore \Delta ABC = \Delta EBC. \quad \text{Prop. 37.}$$

$$\text{But } \Delta ABC = \Delta DBC. \quad \text{Hyp.}$$

$$\therefore \Delta EBC = \Delta DBC,$$

the part = the whole,

which is impossible.

$$\therefore AE \text{ is not } \parallel BC.$$

Similarly it may be shown that no other line drawn through A, but AD, is paral. to BC.

$$\therefore AD \parallel BC.$$

PROPOSITION 40. THEOREM.

Equal triangles on equal bases, in the same straight line, and on the same side of it, are between the same parallels.

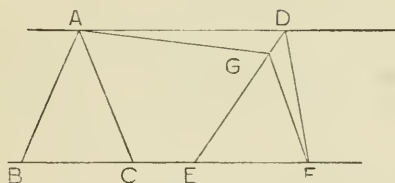

Let the Δ s ABC , DEF , be on equal bases BC and EF in the same st. line BF , and on the same side of BF .

Join AD .

It is required to prove $AD \parallel BF$.

Construction. If AD is not $\parallel BF$, draw $AG \parallel BF$, meeting ED , or ED produced, in G , and join GF .

Proof. $\therefore \Delta$ s ABC , GEF are on equal bases BC and EF , and between the same \parallel s,

$$\therefore \Delta ABC = \Delta GEF. \quad \text{Prop. 38.}$$

$$\text{But } \Delta ABC = \Delta DEF,$$

$$\therefore \Delta GEF = \Delta DEF,$$

the part = the whole,

which is impossible.

$$\therefore AG \text{ is not } \parallel BF.$$

Similarly it may be shown that no other line drawn through A , but AG , is parl. to BF .

$$\therefore AG \parallel BF.$$

PROPOSITION 41. THEOREM.

If a parallelogram and a triangle be on the same base and between the same parallels, the parallelogram shall be double the triangle.

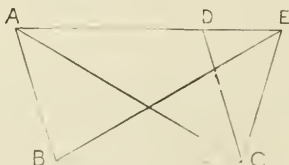

Let the $\parallel m$ ABCD, and the \triangle EBC, be on the same base BC, and between the same parallels, AE and BC.

It is required to prove $\parallel m$ ABCD = double of \triangle EBC.

Construction. Join AC.

Proof. \therefore \triangle s ABC, EBC are on the same base and between the same \parallel s,

$$\therefore \triangle ABC = \triangle EBC. \quad \text{Prop. 37.}$$

But \therefore AC is a diagonal of $\parallel m$ ABCD,

$$\therefore \parallel m ABCD = \text{double of } \triangle ABC. \quad \text{Prop. 34.}$$

$$\therefore \parallel m ABCD = \text{double of } \triangle EBC.$$

EXERCISES.

1. Prove that equal triangles which have equal bases, have also equal altitudes.
2. If a quadrilateral is bisected by each of its diagonals, show that it is a parallelogram.
3. Equal triangles are on opposite sides of the same base. Show that the straight line joining the vertices is bisected by the base, or the base produced.
4. The straight line joining the middle points of two sides of a triangle is parallel to the third side and is equal to half of it.
5. The straight lines which join the middle points of adjacent sides of a quadrilateral, form a parallelogram.
6. Show that the straight lines joining the vertices of a triangle to the middle points of the opposite sides meet in a point, which is for each line the point of trisection remote from the vertex.
7. If the point E be joined to the angular points of the parallelogram ABCD, the sum of the triangles EAB, ECD is equal to half the parallelogram if E lies between the lines AB and CD, or these lines produced. If E does not lie between these lines, the difference of the triangles is equal to half the parallelogram.

PROPOSITION 42. PROBLEM.

To describe a parallelogram equal to a given triangle, and having one of its angles equal to a given angle.

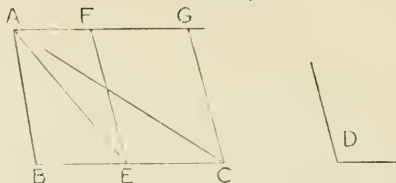

Let $\triangle ABC$ be the given \triangle , and $\angle D$ be the given \angle .

It is required to make a $\parallel m$, = $\triangle ABC$, and having one of its \angle s equal to $\angle D$.

Construction. Bisect BC in E . *Prop.* 10.

Join AE .

At E in the st. line EC , make $\angle CEF = \angle D$. *Prop.* 23.

Through C draw $CG \parallel EF$, and through A draw $AG \parallel BC$, meeting EF and CG in F and G respectively.

Then $FECG$ is the required $\parallel m$.

Proof. $\because AG \parallel BC$, and base $BE =$ base EC ,

$\therefore \triangle ABE = \triangle AEC$. *Prop.* 38.

$\therefore \triangle ABC =$ double of $\triangle AEC$.

Again, $\because \parallel m$ $FECG$ and $\triangle AEC$ are on the same base EC , and between the same \parallel s, BC and AG .

$\therefore \parallel m$ $FECG =$ double of $\triangle AEC$. *Prop.* 41.

$\therefore \parallel m$ $FECG = \triangle ABC$, *Ax.*

and it has $\angle FEC = \angle D$.

NOTE:—If two straight lines are drawn through a point in the diagonal of a parallelogram parallel to the sides, then the whole figure is divided into four parallelograms. Of these, the two which have the same diagonal as the original parallelogram are called **parallelograms about the diagonal**, and the other two are called the **complements** of the parallelograms about the diagonal.

PROPOSITION 43. THEOREM.

The complements of the parallelograms about the diagonal of a parallelogram are equal.

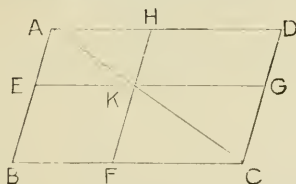

Let $ABCD$ be a $\parallel m$, of which AC is a diagonal; and let $EBFK$, and $HKGD$ be $\parallel ms$, which are complements of the $\parallel ms$ $AEKH$, $KFCG$ which are about the diagonal AC .

It is required to prove $\parallel m$ $EBFK = \parallel m$ $HKGD$.

Proof. \because a $\parallel m$ is bisected by its diagonal, *Prop.* 34.

$$\therefore \triangle ABC = \triangle ADC,$$

$$\triangle AEK = \triangle AHK,$$

$$\text{and } \triangle KFC = \triangle KGC.$$

From $\triangle ABC$ take the sum of $\triangle s$ AEK , KFC ,
and from $\triangle ADC$ take the equal sum of $\triangle s$ AHK , KGC .

\therefore remainder $\parallel m$ $EBFK =$ remainder $\parallel m$ $HKGD$. *Ax.*

EXERCISES.

1. In the figure of *Prop.* 43 show that EH is parallel to BD .
2. Also prove that EH is parallel to FG .

NOTE.—A parallelogram, or any other quadrilateral, is sometimes named by two letters placed at opposite vertices.

PROPOSITION 44. PROBLEM.

On a given straight line to describe a parallelogram which shall be equal to a given triangle, and have one of its angles equal to a given angle.

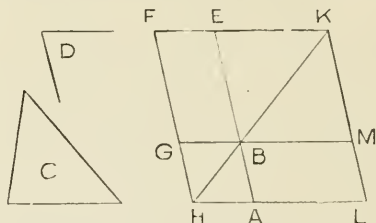

Let AB be the given straight line, C the given Δ , and D the given \angle .

It is required to describe on AB a $\parallel m$, $= \Delta C$, and having an angle $= \angle D$.

Construction. Describe the $\parallel m$ $BEFG = \Delta C$, and having $\angle EBG = \angle D$; and let it be so placed that BE may be in the same straight line with AB . *Prop. 42.*

Through A draw $AH \parallel BG$ or EF , *Prop. 31.*
and let it meet FG produced at H .

Join HB .

Now, \because HF meets the $\parallel s$ AH , EF ,

$\therefore \angle s$ AHF , HFE together $=$ two rt. $\angle s$; *Prop. 29.*

$\therefore \angle s$ BHF , HFE are together less than two rt. $\angle s$;

\therefore HB , FE , if produced, will meet towards B , E . *Ax. 12.*

Let them be produced and meet at K .

Through K draw $KML \parallel EA$ or FH , *Prop. 31.*

and produce HA , GB to L and M .

$ABML$ is the $\parallel m$ required.

Proof. For FHLK is a $\parallel m$, of which HK is a diagonal,
 and AG, ME are $\parallel m$ s about HK,
 \therefore complement $\parallel m$ AM = complement $\parallel m$ GE, *Prop.* 43.
 $\therefore \parallel m$ ABML = Δ C.
 And \angle ABM = vertically opp. \angle EBG, *Prop.* 15.
 $\therefore \angle$ ABM = \angle D.

PROPOSITION 45. PROBLEM.

To describe a parallelogram equal to a given rectilineal figure, and having an angle equal to a given angle.

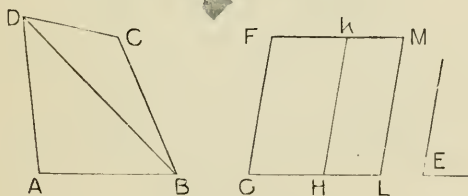

Let ABCD be the given rectilineal figure, and \angle E the given angle.

It is required to describe a $\parallel m$ equal to fig. ABCD, and having an angle = \angle E.

Construction. Join BD.

Describe a $\parallel m$ FGHK, = Δ ABD, and having \angle FGH = \angle E. *Prop.* 42.

To KH apply the $\parallel m$ KHLM, = Δ DBC, and having \angle KHL = \angle FGH. *Prop.* 44.

FGLM is the required $\parallel m$.

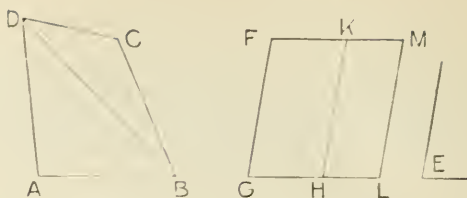

Proof. $\therefore \angle FGH = \angle KHL$,
 \therefore sum of \angle s $FGH, KHG =$ sum of \angle s KHG, KHL .
 But $\therefore FG \parallel KH$,
 \therefore sum of int. \angle s $FGH, KHG =$ two rt. \angle s. *Prop. 29.*
 \therefore sum of adjacent \angle s $KHG, KHL =$ two rt. \angle s.
 $\therefore GH$ and HL are in the same st. line. *Prop. 14.*
 Again, $\therefore FK \parallel GL$.
 $\therefore \angle FKH =$ alternate $\angle KHL$. *Prop. 29.*
 \therefore sum of \angle s $FKH, HKM =$ sum of \angle s KHL, HKM .
 But sum of \angle s $KHL, HKM =$ two rt. \angle s.
 \therefore sum of adjacent \angle s $FKH, HKM =$ two rt. \angle s.
 $\therefore FK$ and KM are in the same st. line.
 Again, $\therefore FG$ and ML are each $\parallel KH$,
 $\therefore FG \parallel ML$. *Prop. 30.*
 \therefore fig. $FGLM$ is a \parallel m,
 and its parts are equal respectively to the parts of the
 given rectilinear figure, and $\angle FGL = \angle E$,
 $\therefore \parallel$ m $FGLM$ is the required \parallel m.

EXERCISES.

1. Construct a rectangle equal to a given rectilinear figure.
2. Construct an isosceles triangle equal to a given triangle.
3. Construct a rhombus equal to a given rectilinear figure.
4. Construct a rhombus equal to a given rectilinear figure, and having a diagonal equal to a given straight line.
5. Construct a rectangle equal to the sum of two given rectangles.

PROPOSITION 46. PROBLEM.

On a given straight line to describe a square.

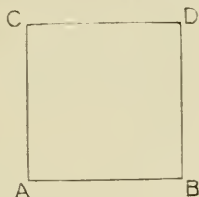

Let AB be the given straight line.

It is required to describe a square on AB .

Construction. From A draw $AC \perp AB$, *Prop.* 11.
and make $AC = AB$.

Through C draw $CD \parallel AB$, *Prop.* 31.
and through B draw $BD \parallel AC$,
meeting CD in D .

$ABDC$ is the square required.

Proof. $\therefore ABDC$ is a $\parallel m$, *Def.*
 $\therefore AB = \text{opp. side } CD$, and $AC = \text{opp. side } BD$. *Prop.* 34.
But $AB = AC$; *Constr.*

\therefore the four sides AB, BD, DC, CA are all equal.

And $\therefore AC$ meets the $\parallel s AB, CD$,
 $\therefore \angle A$ and $\angle C$ together = two rt. $\angle s$. *Prop.* 29.
But $\angle A$ is a rt. \angle .

$\therefore \angle C$ is also a rt. \angle .

Now, $\angle A = \text{opp. } \angle D$ and $\angle C = \text{opp. } \angle B$; *Prop.* 34.

\therefore the four $\angle s A, B, D, C$ are rt. $\angle s$.

and $\therefore \angle ABDC$ is a square. *Def.*

EXERCISES.

1. Make a rectangle, two of the adjacent sides of which shall be equal to two given straight lines.
2. Construct a square, having a given straight line as one diagonal.

PROPOSITION 47. THEOREM.

In a right-angled triangle, the square described on the hypotenuse is equal to the sum of the squares described on the other two sides.

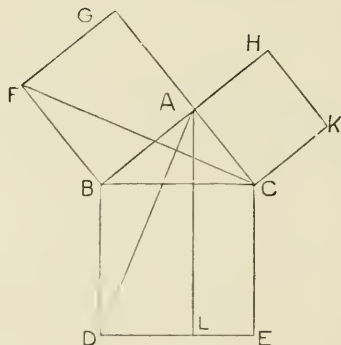

Let ABC be a right-angled Δ , having $\angle BAC$ a rt. \angle .

It is required to prove that the square described on BC is equal to the sum of the squares described on AB and AC .

Construction. On AB , BC , CA describe the squares $AGFB$, $BDEC$, and $ACKH$ respectively. *Prop.* 46.

Through A draw $AL \parallel BD$ or CE , *Prop.* 31.
meeting DE in L . Join AD and FC .

Proof. \therefore the adjacent \angle s BAG , BAC are two rt. \angle s,
 $\therefore GA$ and AC are in one st. line. *Prop.* 14.

Similarly BA and AH are in one st. line.

Again, rt. $\angle CBD =$ rt. $\angle ABF$.

To each add $\angle ABC$.

\therefore whole $\angle ABD =$ whole $\angle FBC$.

In Δ s ABD, FBC,

$$AB = FB,$$

$$BD = BC,$$

and included \angle ABD = included \angle FBC,

$$\therefore \Delta ABD = \Delta FBC. \text{ Prop. 4.}$$

But $\parallel m$ BL = double of Δ ABD, being on the same base BD, and between the same \parallel s BD and AL. *Prop.* 41.

And sq. AGFB = double of Δ FBC, being on the same base FB, and between the same \parallel s FB and GC. *Prop.* 41.

$$\therefore \parallel m BL = sq. AGFB.$$

Similarly it may be shown, by joining AE and BK, that $\parallel m$ CL = sq. ACKH.

\therefore sum of $\parallel m$ s BL, CL = sum of squares AGFB, ACKH.

\therefore square BDEC = sum of squares AGFB, ACKH.

That is, the square on BC = the sum of the squares on AB and AC.

EXERCISES.

1. Construct a square equal to the sum of two given squares.
2. Construct a square equal to the difference of two given squares.
3. Divide a given straight line into two parts so that the sum of the squares on the parts may be equal to the square on another given straight line.
4. Divide a given straight line into two parts so that the difference of the squares on the parts may be equal to the square on another given straight line.
5. The square on a straight line is four times the square on half the line.

PROPOSITION 48. THEOREM.

If the square described on one side of a triangle be equal to the sum of the squares described on the other two sides, the angle contained by these two sides is a right angle.

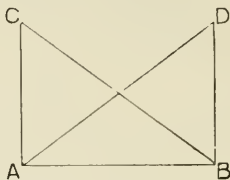

Let ABC be a Δ , such that the square described on the side $BC =$ the sum of the squares described on AB and AC .

It is required to prove $\angle BAC =$ a rt. \angle .

Construction. From B draw $BD \perp AB$, *Prop. 11.*
and make $BD = AC$. Join AD .

Proof. $\because BD = AC$, *Constr.*

\therefore sq. on $BD =$ sq. on AC .

To each add sq. on AB .

\therefore the sum of the squares on AB and BD
 $=$ the sum of the squares on AB and AC .

But $\because \angle ABD$ is a rt. \angle ,

\therefore the sum of the squares on AB and BD
 $=$ the sq. on AD . *Prop. 47.*

But the sum of the squares on AB and AC
 $=$ the sq. on BC . *Hyp.*

\therefore the sq. on $AD =$ the sq. on BC ,
and, $\therefore AD = BC$.

Now, in Δ s ABD , BAC ,

$BD = AC$,

$AB = AB$,

and base $AD =$ base BC ,

\therefore included $\angle ABD =$ included $\angle BAC$.

But $\angle ABD$ is a rt. \angle . *Constr.*

$\therefore \angle BAC$ is a rt. \angle .

EXERCISES.

EQUILATERAL TRIANGLE.

1. In Prop. I, if AB be produced to meet the circumferences in D and E, the triangles CDF and CEF are equilateral.
2. In Prop. I, if CA and CB be produced to meet the circumferences again in G and H, the points G, F, H are in a straight line, and the triangle GCH is equilateral.
3. In Prop. I, if CF be joined, $CF^2 = 3AB^2$.
4. The bisector of an angle of an equilateral triangle, bisects the base at right angles.
5. The perpendicular from an angle of an equilateral triangle upon the third side, bisects that side and the vertical angle.
6. The median of an equilateral triangle bisects the vertical angle and is perpendicular to the base.
7. If the three medians of a triangle are equal, the triangle is equilateral.
8. If equilateral triangles be described on the sides of any triangle, the distances between the vertices of the original triangle and the opposite vertices of the equilateral triangles are equal.
9. If three points be taken on the sides of an equilateral triangle, namely, one on each side, at equal distances from the angles, the lines joining them form a new equilateral triangle.
10. Inscribe a square in a given equilateral triangle, having its base on a given side of the triangle.
11. In a given square inscribe an equilateral triangle having one angle in the corner of the square.
12. In an equilateral triangle, three times the square on any side is equal to four times the square on the perpendicular to it from the opposite vertex.
13. The sum of the perpendiculars from any point in an equilateral triangle is equal to the perpendicular from an angle to the opposite side.
14. Through two given points draw two straight lines that shall form with a given straight line an equilateral triangle.
15. Given the perpendicular from one angle of an equilateral triangle on the opposite side, construct the triangle.
16. Given the perpendiculars on the three sides of an equilateral triangle from any point, construct the triangle.

17. The distances of a certain point within an equilateral triangle from the angular points being given, construct the triangle.
18. Straight lines joining three alternate angles of a regular hexagon form an equilateral triangle.
19. Equilateral triangles are described on the sides of a square, and their vertices E, F, G, H are joined; show that EFGH is a square.
20. The equilateral triangle described on the hypotenuse of a right-angled triangle is equal to the sum of the equilateral triangles described on the sides.
21. Show how to construct an equilateral triangle equal in area to (*a*) two given equilateral triangles, (*b*) any given number of equilateral triangles.
22. On the sides AB, BC of the parallelogram ABCD equilateral triangles ABP, BCQ are described exterior to the parallelogram; show that the triangle PQD is equilateral.
23. On the sides AB, BC, and CD of a parallelogram ABCD three equilateral triangles are described, that on BC towards the same parts as the parallelogram, and those on AB, CD towards the opposite parts; show that the distances of the vertices of the triangles on AB, CD from that on BC are respectively equal to the two diagonals of the parallelogram.
24. Construct an equilateral triangle, one of whose angular points is given, and the other two lie one on each of two given straight lines.

ISOSCELES TRIANGLE.

25. Upon a given base describe an isosceles triangle having each of its sides of given length.
26. The perpendicular from the vertex on the base of an isosceles triangle bisects (*a*) the triangle, (*b*) the base, (*c*) the vertical angle.
27. The median from the vertex to the base of an isosceles triangle (*a*) bisects the triangle, (*b*) bisects the vertical angle, (*c*) is perpendicular to the base.
28. The bisector of the vertical angle of an isosceles triangle (*a*) bisects the triangle, (*b*) bisects the base, (*c*) is perpendicular to the base.
29. If the line which bisects the vertical angle of a triangle also bisects the base the triangle is isosceles.

30. If the bisector of the vertical angle of a triangle be perpendicular to the base the triangle is isosceles.
31. The extremities of the base of an isosceles triangle are equally distant from any point in the perpendicular from the vertical angle to the base.
32. Through a given point draw a straight line intersecting two given lines, and forming an isosceles triangle with them.
33. Make an isosceles triangle equal to a given triangle and on the same base.
34. Of all equal triangles on the same base the isosceles triangle has the least perimeter.
35. In an isosceles triangle each of the equal angles is acute.
36. From two given points on the same side of a given line, draw two lines which shall meet in that line and make equal angles with it.
37. Find a point in a given straight line such that the sum of its distances from two fixed points on the same side of the line may be the least possible.
38. A straight line drawn at right angles to BC the base of an isosceles triangle ABC cuts the side AB at D and CA produced at E ; show that AED is an isosceles triangle.
39. The perpendiculars drawn from the extremities of the base of an isosceles triangle to the opposite sides are equal.
40. ABC is an isosceles triangle; find points D, E in the equal sides AB, AC such that BD, DE, EC may all be equal.
41. If the base of an isosceles triangle be produced to any point, the difference of the perpendiculars drawn from this point to the equal sides is constant.
42. If the straight lines bisecting the angles at the base of an isosceles triangle be produced to meet, they will contain an angle equal to an exterior angle of the triangle.
43. A is the vertex of an isosceles triangle ABC , and BA is produced to D so that AD is equal to BA , and DC is joined. Show that the angle BCD is a right angle.
44. Any right angled triangle can be divided into two isosceles triangles.
45. The straight lines bisecting the base angles of an isosceles triangle meet the sides in D and E . Show that DE is parallel to the base.
46. Construct, on a given base, an isosceles triangle having the vertical angle four times each of the base angles.

47. Construct, on a given base, an isosceles triangle having one-third of each angle at the base equal to half the vertical angle. Construct an isosceles triangle having given:—
48. The vertical angle and one of the equal sides.
49. The base and one of the angles at the base.
50. The vertical angle and the perpendicular from it on the base.
51. The perimeter and the perpendicular from the vertex to the base.
52. Make an isosceles triangle of given altitude, whose sides shall pass through two given points and its base be on a given straight line.
53. ACB , ADB are two triangles on the same side of AB , such that AC is equal to BD and AD to BC ; BC and AD intersect at O ; show that the triangle AOB is isosceles.
54. If two isosceles triangles are on the same base, the straight line joining their vertices will bisect the base at right angles.
55. GHK is an isosceles triangle: find a point P within it such that the triangles PGH , PGK , PHK may be equal to one another.
56. An equilateral and an isosceles triangle have a common side, and each of the angles at the base of the isosceles triangle is double of the angle at the vertex. Show that the base of the isosceles triangle is less than the base of the equilateral.
57. ABC is an isosceles triangle; pairs of lines BE , CD , BG , CF , making equal angles with BC , are drawn to meet the opposite sides in E , D , and G , F . Show that FG is parallel to DE .
58. If an acute angle of a triangle be double of another, the triangle can be divided into two isosceles triangles.
59. In the figure of Prop. I, if AB produced both ways meet the circles again in D and E and CD , CE be drawn, CDE will be an isosceles triangle having one angle four times each of the other angles.
60. The angle made with the base of an isosceles triangle by perpendiculars from its extremities on the equal sides are each equal to half the vertical angle.
61. ABC is a right angled isosceles triangle; show that the square on the hypotenuse is four times the area of the triangle.
62. Upon a given base describe an isosceles triangle equal to a given triangle.
63. Find a point in a given line which shall be equally distant from two given points.

64. If from any point within an isosceles triangle perpendiculars be let fall on the base and sides, the sum of these perpendiculars is less than the altitude of the triangle if the vertical angle be less than the angle of an equilateral triangle.
65. Trisect a given straight line.
66. If AB , AC be equal sides of an isosceles triangle, and if BD be a perpendicular on AC : prove that $BC^2 = 2AC \cdot CD$.
67. The sum of the distances of any point in the base of an isosceles triangle from the equal sides is equal to the distance of either extremity of the base from the opposite side.
68. If two lines bisecting two angles of a triangle and terminated by the opposite sides be equal, the triangle is isosceles.
69. A straight line is drawn terminated by one of the sides of an isosceles triangle, and by the other side produced, and bisected by the base: prove that the straight lines thus intercepted between the vertex of the isosceles triangle, and this straight line, are together equal to the two equal sides of the triangle.
70. If the straight lines joining the middle points of two of the sides of a triangle to the opposite vertices be equal, the triangle is isosceles.
71. ABC is a triangle, BD , CE straight lines drawn making equal angles with BC , and meeting the opposite sides in D and E and each other in F ; prove that, if the angle AFE is equal to the angle AFD , the triangle is isosceles.
72. Of all triangles formed with a given angle which is contained by two sides whose sum is constant, the isosceles triangle has the least perimeter.

TRIANGLE.

73. Draw, parallel to the base of a triangle and terminated by the sides, a straight line of given length.
74. If in a triangle ABC , ACB be a right angle, and the angle CAB be double the angle ABC , then AB is double BC .
75. Points A , B , C are taken on three parallel lines; BC , CA , AB , produced if necessary, meet the lines through A , B , C respectively in the points D , E , F . Prove that the triangles AEF , BFD , CDE are all equal.
76. The straight line joining the middle points of two sides of a triangle is parallel to the third side.
77. The straight line joining the middle points of two sides of a triangle is equal to half the base.

78. The straight lines joining the middle points of the sides of a triangle divide the triangle into four equal triangles.
79. Given the middle points of the sides of a triangle, construct it.
80. The triangle whose vertices are the middle points of two sides and any point in the base, of another triangle, is one-fourth of that triangle.
81. In the base AC of a triangle ABC , take any point D ; bisect AD , CD , AB , BC at the points E , F , G , H respectively; show that EG is equal and parallel to FH .
82. The sides AB , AC of a given triangle ABC are bisected at the points E , F ; a perpendicular is drawn from A to the opposite side, meeting it at D . Show that the angle FDE is equal to the angle BAC ; show also that $AFDE$ is half the triangle ABC .
83. ABC , DBC are two triangles on the same base BC ; E , F , G , H are the middle points of AB , AC , DB , DC respectively; join EF , FH , HG , GE and show that $EFHG$ is a parallelogram.
84. From any point P on the side BC of the triangle ABC , lines PQ , PR are drawn parallel to AB , AC respectively and meeting AC , AB respectively in the points Q , R . Show that the parallelogram $PQAR$ is greatest when P is the middle point of BC .
85. The medians of a triangle are concurrent.
86. If O be the point of intersection of the medians, of the triangle ABC , prove that the triangles AOB , BOC , and COA are equal.
87. Show that the medians pass through a point of trisection.
88. The sum of the three medians is less than the perimeter of the triangle.
89. The sum of the three medians is greater than three-fourths of the perimeter of the triangle.
90. Construct a triangle having given two sides and the median of the third side.
91. Construct a triangle having given one side and the two medians of the remaining sides.
92. Construct a triangle having given the three medians.
93. The middle points of the sides AB , BC , CA of a triangle are respectively D , E , F ; DG is drawn parallel to BF to meet EF in G ; prove that the sides of the triangle DCG are respectively equal to the medians of the triangle ABC .

94. Prove that the triangle formed by the medians of a triangle is equal to three-fourths the original triangle.
95. Through a given point draw a line so that the portion intercepted by the arms of a given angle may be bisected in the point.
96. The bisectors of the three internal angles of a triangle are concurrent.
97. The bisectors of the two external angles and the bisector of the third internal angle are concurrent.
98. If squares be described on the sides of a triangle, the lines of connection of the adjacent corners are respectively—(a) the doubles of the medians of the triangle; (b) perpendicular to them.
99. The bisector of the vertical angle of a triangle divides the base into parts such that the greater is next the greater side of the triangle.
100. If one side of a triangle be greater than another, the bisector of the angle opposite to it is less than the bisector of the angle opposite to the other.
101. The angle included between the perpendicular from the vertical angle of a triangle to the base, and the bisector of the vertical angle, is equal to half the difference of the base angles.
102. The shortest median of a triangle corresponds to the longest side.
103. The three perpendiculars at the middle points of the sides of a triangle are concurrent.
104. Inscribe a square in a triangle having its base on a side of the triangle.
105. The hypotenuse of a right-angled triangle, together with the perpendicular on it from the right angle, is greater than the sum of the other two sides.
106. The distance of the foot of the perpendicular, from either extremity of the base of a triangle, on the bisector of the vertical angle, to the middle point to the base, is equal to half the difference of the sides.
107. In the same case, if the bisector of the external vertical angle be taken, the distance will be equal to half the sum of the sides.
108. The three perpendiculars of a triangle, from the vertices to the opposite sides, are concurrent.

109. The perpendiculars of a triangle are the bisectors of the angles of the triangle whose vertices are the feet of these perpendiculars.
110. If any point within a triangle be joined to its angular points, the sum of the joining lines is less than its perimeter and greater than its semi-perimeter.
111. If through the extremities of the base of a triangle, whose sides are unequal, lines be drawn to any point in the bisector of the vertical angle, their difference is less than the difference of the sides.
112. If lines be drawn to any point in the bisector of the external vertical angle from the extremities of the base, their sum is greater than the sum of the sides.
113. The perimeter of any triangle is greater than that of any inscribed triangle, and less than that of any circumscribed triangle.
114. Through a given point draw a straight line such that perpendiculars on it from two given points on opposite sides may be equal to each other.
115. If the three sides of one triangle be respectively perpendicular to the three sides of another triangle, the triangles are equiangular.
116. The angle included between the internal bisector of one base angle of a triangle and the external bisector of the other base angle is equal to half the vertical angle.
117. Bisect a given triangle by a straight line drawn from a given point in one of the sides.
118. Trisect a given triangle by three lines drawn from a given point within it.
119. Trisect a given triangle by straight lines drawn from a given point in one of its sides.
120. The triangle formed by joining the middle point of one of the non-parallel sides of a trapezium to the extremities of the opposite side is equal to half the trapezium.
121. Four times the sum of the squares on the medians which bisect the sides of a right-angled triangle is equal to five times the square on the hypotenuse.
122. If from the angles of the triangle ABC , straight lines AOD , BOE , COF be drawn through a point O within the triangle to meet the opposite sides, the perimeter of the triangle ABC is greater than two-thirds of the sum of AD , BE , CF .

123. The line joining the right angle of a right-angled triangle to the middle point of the hypotenuse is equal to half the hypotenuse.
124. Points E, F are taken on the sides CA, AB of the triangle ABC such that $AE = 2EC$ and $BF = 2FA$, and the lines BE and CF intersect in O; show that $BO = 6OE$.
125. Find in a side of a triangle a point from which straight lines drawn parallel to the other sides of the triangle and terminated by them are equal.
126. If the sides BC, CA, AB of a triangle ABC be produced to L, M, N respectively, so that $CL = BC$, $AM = CA$, $BN = AB$, prove that the area of the triangle LMN is seven times that of the triangle ABC.
127. The triangle ABC is double of the triangle EBC and on the same side of the base: show that if AE, BC produced if necessary meet in D, then AE is equal to ED.
128. O is the point of intersection of the perpendiculars drawn from the angles of a triangle upon the opposite sides, the squares on OA and BC are together equal to the squares on OB and CA, and also to the squares on OC and AB.
129. From a point P outside an angle BAC draw a straight line cutting the straight lines AB, AC in points D and E such that PD may be equal to DE.
130. The sides AB, AC of a triangle are bisected in D, E, and BE, CD are produced to F, G, so that EF is equal to BE, and DG to CD: prove that FAG is a straight line.
131. If the sides of a triangle be trisected and straight lines be drawn through the points of section adjacent to each angle so as to form another triangle, this is equal to the original triangle in every respect.
132. If a triangle be described having two of its sides equal to the diagonals of any quadrilateral, and the included angle equal to either of the angles between these diagonals, then the area of the triangle is equal to the area of the quadrilateral.
133. ABC is a triangle. The side CA is bisected in D, and E is the point of trisection of the side BC which is nearer to B: show that the line joining A to E bisects the line joining B to D.
134. ABC is a triangle; ADF, CFE are the perpendiculars let fall from A and C, one on the internal bisector of the angle B and the other on the external bisector; the area of the rectangle BDFE is equal to that of the triangle.

135. Upon BC , CA , AB , sides of the triangle ABC , perpendiculars are drawn from a point D , meeting the sides, or the sides produced in E , F , G , respectively. Prove that the sum of the squares in AG , BE , CF is equal to the sum of the squares on BG , CE , AF .
136. Construct a right-angled triangle, having given the hypotenuse and the sum or difference of the sides.
137. Construct a right-angled triangle, having given the hypotenuse and the perpendicular from the right angle on it.
138. Construct a right-angled triangle having given the perimeter and an acute angle.
139. Construct a right-angled triangle, having given an acute angle and the sum or difference of the sides about the right angle.
140. Construct a triangle having given the base, one of the angles at the base, and the sum or difference of the sides.
141. Construct a triangle having given two sides and the angle opposite to one of them. Is this always possible?
142. Given the altitude of a triangle and the base angles, construct it.
143. Given one angle, and the opposite side, and the sum of the other sides, construct the triangle.
144. Construct the smallest triangle, which has a given vertical angle, and whose base passes through a given point.
145. Construct a triangle of given perimeter, having its angles equal to those of a given triangle.
146. Construct a triangle having given an angle, its bisector and the perpendicular from the angle on the opposite side.
147. Construct a triangle whose angles shall be equal to those of a given triangle and whose area shall be four times the area of the given triangle.
148. ABC is a given triangle; construct a triangle of equal area, having for its base a given straight line AD , coinciding in position with AB .
149. ABC is a given triangle; construct a triangle of equal area, having its vertex at a given point in BC and its base in the same straight line as AB .
150. ABC is a given triangle; construct a triangle of equal area, having its base in the same straight line as AB , and its vertex in a given straight line parallel to AB .

151. Given the base of a triangle, the difference of the base angles, and the sum or difference of the sides ; construct it.
152. Given the base of a triangle, the median that bisects the base, and the area ; construct it.

QUADRILATERAL.

153. Show how to find a square equal to the sum of two given squares.
154. Show how to find a square equal to the sum of any given number of squares.
155. The squares described on the two diagonals of a rhombus are together equal to the squares described on the four sides.
156. If from the vertex of a triangle a perpendicular be drawn to the base, the difference of the squares on the sides of the triangle is equal to the difference of the squares on the segments of the base.
157. ABCD is a square, and a line APQ is drawn through A cutting DC in P and BC produced in Q. Show that the sum of AP and AQ is greater than twice AC.
158. Prove that the straight line, bisecting the right angle of a right-angled triangle, passes through the intersection of the diagonals of the square constructed on the outer side of the hypotenuse.
159. The sum of the squares of the distances of any point from two opposite corners of a rectangle is equal to the sum of the squares of its distances from the other two corners.
160. On the sides AC, BC of a triangle ABC, squares ACDE, BCFH are described : show that the straight lines AF and BD are equal.
161. A straight line is drawn parallel to the hypotenuse of a right-angled triangle, and each of the acute angles is joined with the points where the straight line intersects the sides respectively opposite to them : show that the squares on the joining straight lines are together equal to the square on the hypotenuse and the square on the straight line drawn parallel to it.
162. In a right-angled triangle if the square on one of the sides containing the right angle be three times the square on the other, and from the right angle two straight lines be drawn, one to bisect the opposite side, and the other perpendicular to that side, these straight lines divide the right angle into three equal parts.

163. On the hypotenuse BC , and the sides CA , AB of a right-angled triangle ABC , squares $BDEC$, AF , and AG are described: show that the squares on DG and EF are together equal to five times the square on BC .
164. BAC is a right-angled triangle, A being a right angle. $ACDE$, $BCFG$ are square on AC and BC . AC produced meets DF in K . Prove that DF is bisected in K and that AB is double of CK .
165. If on the sides AB , BC , CA of any triangle, squares $ABEF$, $BCGH$, $CAKL$ be constructed, and EH , GL , KF be drawn, then all the triangles ABC , BEH , CGL , AKF are equal to one another.
166. Construct a square, which shall have two adjacent sides passing through two given points, and the intersection of diagonals at a third given point.
167. If the sum of the squares on two opposite sides of a quadrilateral be equal to the sum of the squares on the other two sides, the diagonals of the quadrilateral intersect at right angles.
168. $ABCD$ is a square and any point E is taken in AB , and in BC , CD , DA respectively points F , G , H are taken so that each of the lines BF , CG , DH is equal to AE . Show that $EFGH$ is a square.
169. Find the square of least area whose angular points are respectively on the four sides of a given square.
170. If a square be inscribed in a triangle the rectangle under its side and the sum of base and altitude equals twice the area of the triangle.
171. P is any point in the side CD of a square $ABCD$ such that AP is equal to the sum of PC and CB , and Q is the middle point of CD . Prove that the angle BAP is twice the angle QAD .
172. If two equal straight lines intersect each other anywhere at right angles, the quadrilateral formed by joining their extremities is equal to half the square on either straight line.
173. Show that the four internal bisectors of the angles of any parallelogram are the sides of a rectangle whose diagonals are parallel to the sides of the original parallelogram and equal to the difference of them.
174. The external angles of a parallelogram are bisected, prove that the quadrilateral formed by the four bisectors is a rectangle, the sum of whose diagonals is equal to the perimeter of the parallelogram.

175. If the diagonals of a parallelogram be equal to each other, it is a rectangle.
176. If the diagonals of a parallelogram bisect the angles through which they pass, the parallelogram is a rhombus.
177. If the diagonals cut each other perpendicularly, the parallelogram is a rhombus.
178. If the diagonals of a parallelogram be equal and cut each other perpendicularly, the parallelogram is a square.
179. Every straight line drawn through the intersection of the diagonals of a parallelogram, and terminated by a pair of opposite sides, is bisected and bisects the parallelogram.
180. If from any point within a parallelogram straight lines be drawn to the ends of two opposite sides, the sum of the triangles on these sides shall be equal to half the parallelogram.
181. ABCD is a quadrilateral, AC and BD its diagonals. A parallelogram EFGH is formed by drawing through A, B, C, D parallels to AC and BD. Prove ABCD equals half of EFGH.
182. On a given straight line describe an isosceles triangle equal to a given parallelogram.
183. If straight lines be drawn from the angles of any parallelogram perpendicular to any straight line which is outside the parallelogram, the sum of those from one pair of opposite angles is equal to the sum of the other pair.
184. ABCD is a parallelogram, and E, F the middle points of AD and BC respectively; show that BE and DF will trisect the diagonal AC.
185. ABCD is a quadrilateral having BC parallel to AD; show that its area is the same as that of a parallelogram which can be formed by drawing through the middle point of DC a straight line parallel to AB.
186. ABCD is a quadrilateral having AB parallel to CD; its diagonals AC, BD meet in O. Prove that the triangles AOD and BOC are equal.
187. Bisect a parallelogram by a straight line drawn through a given point.
188. A straight line is drawn bisecting a parallelogram ABCD and meeting AD at E and BC at F. Show that the triangles EBF and CED are equal.

189. ABCD is a parallelogram ; from any point P in the diagonal BD the straight lines PA, PC are drawn. Show that the triangles PAB and PCB are equal.
190. ABCD is a parallelogram ; from D draw any straight line DFG meeting BC in F and AB produced at G ; draw AF and CG ; show that the triangles ABF, CFG are equal.
191. The sides AB, AC of a triangle ABC are bisected in D and E ; CD, BE intersect in F ; prove that the triangle BFC equals the quadrilateral ADFE.
192. A straight line PQ drawn parallel to the diagonal AC of a parallelogram ABCD meets AB in P and BC in Q ; show that the other diagonal BD bisects the quadrilateral BPDQ.
193. ABCD is a parallelogram ; E the point of bisection of AB ; prove that AC, DE being joined will each pass through a point of trisection of the other.
194. Of all parallelograms which can be formed with diagonals of given lengths the rhombus is the greatest.
195. ABC is a triangle and on the side BC a parallelogram BDEC is described, and the parallelogram whose adjacent sides are AD, AB is completed, and also that whose adjacent sides are AE, AC ; show that the sum or the difference of the two latter parallelograms is equal to the first.
196. Construct a parallelogram, having given the two diagonals and a side.
197. Inscribe in a given triangle a parallelogram whose diagonals shall intersect in a given point.
198. Through a point K within a parallelogram ABCD straight lines are drawn parallel to the sides ; show that the difference of the parallelograms of which KA and KC are diagonals is equal to twice the triangle BKD.
199. A straight line AB is bisected at C, and on AC and CB as diagonals any two parallelograms ADCE and CFBG are described ; let the parallelogram whose adjacent sides are CD and CF be completed, and also that whose adjacent sides are CE and CG ; show that the diagonals of these latter parallelograms are in the same straight line.
200. ABCD, ACED are parallelograms on equal bases BC, CE and between the same parallels AD, BE ; the straight lines BD and AE intersect in F ; show that BF is equal to twice DF.
201. Trisect a parallelogram by straight lines drawn through one of its angular points.

202. AHK is an equilateral triangle ; $ABCD$ is a rhombus a side of which is equal to a side of the triangle, and the sides BC and CD of which pass through H and K respectively ; show that the angle A of the rhombus is ten-ninths of a right angle.
203. The straight line joining the middle points of the non-parallel sides of a trapezium is half the sum of the parallel sides and also parallel to them.
204. If two adjacent sides of a quadrilateral be equal, and the diagonal bisects the angle between them, their other sides are equal.
205. Divide a parallelogram into four equal parts by lines drawn through a given point in one of its sides.
206. Show that, if two parallelograms have a common diagonal, their other angular points are at the corners of another parallelogram.
207. If two opposite sides of a quadrilateral be parallel but not equal, and the other pair equal but not parallel, its opposite angles are supplemental.
208. If one diagonal of a quadrilateral bisects the other, it also bisects the quadrilateral, and conversely.
209. Show that, if one pair of opposite sides of a quadrilateral are equal, the middle points of the other two sides and the middle points of the diagonals are at the angular points of a rhombus.
210. $ABCD$ is a quadrilateral : construct a triangle equal to it, having its vertex at A , and for its base BC produced.
211. $ABCD$ is a quadrilateral ; construct a triangle, whose base shall be in the same straight line as AB , its vertex at a given point P in CD , and its area equal to that of a given quadrilateral.
212. The diagonals of a quadrilateral intersect at right angles. Prove that the sum of the squares on one pair of opposite sides is equal to the sum of the squares on the other pair.
213. $ABCD$ is a quadrilateral such that, if any point P be joined to A, B, C, D the sum of the squares on PA, PC is equal to the sum of the squares on PB, PD ; prove that $ABCD$ is a rectangle.
214. Two adjacent sides of a quadrilateral are equal, and the two angles which they form with the other sides are together equal to the angle between the other sides. Prove that one diagonal of the quadrilateral is equal to a side.
215. Draw a straight line equal and parallel to a given straight line and having its extremities on two given straight lines.

216. Convert a quadrilateral into an equivalent triangle.
217. The middle points of the sides of any quadrilateral are the vertices of a parallelogram whose perimeter equals the sum of the diagonals of the quadrilateral and its area half of the quadrilateral.
218. Construct a quadrilateral, the four sides being given in magnitude, and the middle points of two opposite sides being given in position.
219. Bisect a quadrilateral by a straight line drawn from one of its angular points.
220. Bisect a quadrilateral by a straight line drawn from a point in a side.
221. Trisect a quadrilateral by lines drawn from one of its angles.
222. The bisectors of the angles of a (convex) quadrilateral form a quadrilateral whose angles are supplemental. If the first quadrilateral be a parallelogram, the second is a rectangle; if the first be a rectangle, the second is a square.
223. If the diagonals AC, BD of a quadrilateral ABCD intersect in E, and be bisected in F and G then four times the triangle EFG = (AEB + ECD) - (AED + EBC).
224. In every quadrilateral the intersection of the straight lines which join the middle points of opposite sides is the middle point of the straight line which joins the middle points of the diagonals.
225. The straight line joining the middle points of the diagonals of the quadrilateral ABCD meets AD and BC in E and F. Show that the triangles EBC, FAD are each half the quadrilateral.
226. If the diagonals of a quadrilateral intersect at a fixed point and are of given lengths, the area is a maximum when they are at right angles to each other.
227. If a quadrilateral have two of its sides parallel, show that the straight line drawn parallel to these sides through the intersection of the diagonals is bisected at that point.
228. If the opposite sides AB, CD of a quadrilateral meet in P, and if G, H be the middle points of the diagonals AC, BD, the triangle PGH equals one-fourth the quadrilateral ABCD.
229. The middle points of the three diagonals of a complete quadrilateral are collinear.
230. Find a point in the interior of a given quadrilateral such that by joining it to the angular points, the quadrilateral is divided into four triangles, which are equivalent, two and two.

231. If the opposite angles of a quadrilateral are supplementary, a point can be found which is equidistant from the four vertices.
232. If the sum of one pair of opposite sides of a convex quadrilateral is equal to that of the other two, a point can be found which is equidistant from the four sides.

MISCELLANEOUS.

233. ABC is an equilateral triangle, BC is produced to D making $CD = BC$, and AB is produced to E making $BE = 2AB$; show that $ED = 2AD$.
234. Any angle of a triangle is obtuse, right, or acute, according as the opposite side is greater than, equal to, or less than twice the median drawn from that angle.
235. Find in two parallel lines two points which shall be equidistant from a given point, and whose line of connection shall be parallel to a given line
236. Find in two parallel lines two points subtending a right angle at a given point and equally distant from it.
237. Find a point in one of the sides of a triangle such that the sum of the intercepts made by the other sides, on parallels drawn through the point to these sides, may be equal to a given length.
238. The orthocentre, the centroid, and the circumscribed centre of a triangle are collinear, and the distance between the first two is double of the distance between the last two.
239. If a perpendicular be drawn from the vertical angle of a triangle to the base, it will divide the vertical angle and the base into parts such that the greater is next the greater side of the triangle.
240. The median from the vertical angle of a triangle divides the vertical angle into parts such that the greater is next the less side of the triangle.
241. If from the vertex of a triangle there be drawn a perpendicular to the opposite side, a bisector of the vertical angle, and a median, the second of these lies in position and magnitude between the other two.
242. The sum of the three angular bisectors of a triangle is greater than the semiperimeter, and less than the perimeter of the triangle.

243. AB, AC are two straight lines given in position; it is required to find in them two points, P and Q , such that PQ being joined AP and PQ may together be equal to a given straight line, and may contain an angle equal to a given angle.
244. Draw a line parallel to the base BC of the triangle ABC , and cutting the sides AB, AC in the points F, E respectively so that FE may be equal to the sum of BF and CE .
245. If the angle between two adjacent sides of a parallelogram be increased, while their lengths do not alter, the diagonal through their point of intersection will diminish.
246. If a six-sided plane rectilinear figure have its opposite sides equal and parallel, the three straight lines joining the opposite angles will meet in a point.
247. When two sides of a triangle are given in magnitude, the area is a maximum when they contain a right angle.
248. The median from the vertex to the base of a triangle bisects every line parallel to the base and terminated by the sides.
249. From the centres A and B of two circles parallel radii are drawn; the straight line PQ meets the circumferences again at R and S ; show that AR is parallel to BS .
250. A is a given point, and B is a given point in a given straight line; it is required to draw from A to the given straight line, a straight line AP , such that the sum of AP and PB may be equal to a given length.
251. AB, AC are two given straight lines; it is required to find in AB a point P , such that if PQ be drawn perpendicular to AC , the sum of AP and AQ may be equal to a given straight line.
252. On a given straight line as base, construct a triangle, having given the difference of the sides and a point through which one of the sides is to pass.
253. AB and AC are two given straight lines, and P is a given point; it is required to draw through P a straight line which shall form with AB and AC the least possible triangle.
254. BAC is a right-angled triangle; one straight line is drawn bisecting the right angle A , and another bisecting the base BC at right angles; these straight lines intersect at E ; if D be the middle point of BC , show that DE is equal to DA .
255. D is the middle point of the side BC of the triangle ABC , and any line is drawn through D cutting the sides AB, AC produced if necessary in the points P, Q . Show that the triangle APQ is greater than the triangle ABC .

256. If two triangles ABC , ABD be on the same base AB and between the same parallels, and if a parallel to AB intersect the lines AC , BC in E and F , and the lines AD , BD in G and H , EF equals GH .
257. If one angle at the base of a triangle be double of the other, the shorter side is equal to the difference between the segments of the base made by the perpendicular from the vertex.
258. The angle C of a triangle ABC is a right angle, CD is the perpendicular on AB and E is the middle point of AB ; prove that the squares on ED , DC are together equal to the square on EB .
259. Find a point within an isosceles triangle the perpendiculars from which upon the equal sides are each double of the perpendicular on the base.
260. ABC is a triangle BD , BE lines perpendicular to and bisecting the base respectively, F is the middle point of BD ; BG is drawn parallel to EF , meeting AC in G . Prove that AD is equal to CG .
261. Find a point in the base of a triangle equidistant from one extremity of the base and from the side opposite that extremity.
262. A straight line AD is divided into three equal parts by the points B and C ; on AB , BC , CD are described the equilateral triangles AEB , BFC , CGD respectively; show that the three straight lines AE , AF , AG , can form a triangle equal in area to the triangle AEB .
263. O is any point within an equilateral triangle ABC . On OA , OB , OC are described equilateral triangles whose vertices are L , M , N respectively, and are towards the same parts as B , C , A . Show that LMN is an equilateral triangle equal to ABC .
264. In the sides AB , AC of a triangle ABC are taken points D and E at equal distances from A , and a straight line is drawn through D and E to meet BC produced in F . If the angle ABC is one-third of the angle ACB , then the triangle DFB is isosceles.
265. D and E are the middle points of AB , AC sides of a triangle ABC ; in BC or BC produced F is taken; FD and FE produced meet a line through A parallel to BC in G , H ; show that GH equals BC .
266. If E , F are the middle points of the diagonals AC , BD of a quadrilateral $ABCD$, and lines through E , F parallel to BD , AC respectively, meet in G ; show that if H , K be the middle points of AB , BC that the quadrilateral $GHBK$ is one-fourth the original figure.

267. If a point P be taken in the diagonal AC of a parallelogram $ABCD$, two diagonals of the complements PB and PD intersect on AC produced.
268. $ABCD$ is a parallelogram and a straight line drawn parallel to AB meets AD in P , AC in Q , and BC in R ; prove that the triangle APR is equal to the triangle AQD .
269. The bisector of the vertical angle of a triangle and the perpendicular bisector of the opposite side cannot meet within the triangle.
270. The internal and external angles at A of the triangle ABC are bisected by AD and AE respectively, which meet the base BC and BC produced in the points D and E . If the angle ABC be greater than the angle ACB by two-thirds of a right angle, prove that DE is double of DA .
271. A straight line is drawn from the vertex A of a triangle ABC through the middle point of the base to a point D below the base; the lines AB , CD are produced to meet in P , and the lines AC , BD in Q . Prove that PQ is parallel to BC .
272. The four feet of the perpendiculars let fall from one angular point of a triangle on the internal and external bisectors of the other two angles will all lie on a straight line which passes through the middle points of the two sides.
273. Divide a straight line into two parts, the square on one of which may be double the square on the other.
274. DE is parallel to the base BC of the triangle ABC . D and E lie on AC and AB respectively. If BD and CE intersect in O , prove that O is on the median from A to BC .
275. If BD and CE , drawn from the extremities of the base BC of the triangle ABC to the opposite sides intersect on the median from A to BC , DE is parallel to BC .
276. Construct a triangle having given the two sides and the perpendicular from the vertex on the base.
277. Find the point on the base of a triangle such that the difference of the perpendiculars from it on the sides may be equal to a given length.
278. Find a point on the base of a triangle such that the sum of the perpendiculars from it on the sides may be equal to a given length.
279. BD , CE are the perpendiculars from the points B , C respectively, of the triangle ABC , on the internal bisector of the angle BAC . Show that the triangles CAD , ABE are each equal to half the triangle ABC .

280. Divide a triangle into four equal parts by lines drawn through given point in one side.
281. Points D, E, F are taken on the sides BC, CA, AB respectively of a triangle ABC, such that $BD = 2DC$, $CE = 2EA$, $AF = 2FB$. Show that the triangle DEF is one-third the triangle ABC.
282. ABC is a triangle right-angled at A, and on AB, AC are described two equilateral triangles ABD, ACE (both on the outside or both on the inside), and DB and EC or those produced meet in F; show that A is the orthocentre of the triangle DEF.
283. Show that, if the middle points of three of the sides of a quadrilateral be three given points, the middle point of the remaining side will be one or other of three other fixed points.
284. In the figure I. 47, if BAC be any angle, prove the difference of the squares on AB and AC is equal to the difference of the squares on AD and AE.

LOCI.

A locus consists of all the points which satisfy certain conditions, and of those points alone.

1. Find the locus of a point which always remains at a fixed distance from a given point.
2. Find the locus of a point which always remains equidistant from two given points.
3. Find the locus of a point which is equidistant from a given straight line.
4. Find the locus of a point which is equidistant from two given parallel lines.
5. Find the locus of a point which is equidistant from two given lines which intersect.
6. Find the locus of the vertices of all the isosceles triangles which stand on a given base.
7. Find the locus of the vertices of all the triangles which have the same base and equal altitudes.
8. Find the locus of the vertices of all the triangles which have the same base, and their areas equal.
9. Find the locus of the vertices of all the triangles which have the same base, and the median to that base equal to a given length.

10. Find the locus of the middle points of the sides of all triangles on the same base and between the same parallels.
11. From any point in the base of a triangle straight lines are drawn parallel to the sides. Find the locus of the intersection of the diagonals of the parallelograms thus formed.
12. Find the locus of the point at which two equal segments of a straight line subtend equal angles.
13. Find the locus of a point, the sum or the difference of whose distances from two fixed lines is constant.
14. If the angular points of one parallelogram lie on the sides of another fixed parallelogram, find the locus of the intersection of the diagonals of the variable parallelogram.
15. Find the locus of a point the sum of whose distances from the four angular points of a convex quadrilateral is a minimum.
16. The locus of all right-angled triangles which have a common hypotenuse is a circle.
17. Find the locus of the middle points of all straight lines drawn parallel to the base of a triangle and terminated by the sides.
18. Find the locus of the intersections of the diagonals of parallelograms upon the same base and between the same parallels.
19. Given the base and one diagonal of a parallelogram. Find the locus of the extremity of the other diagonal.
20. Find the locus of the centre of a circle which shall pass through a given point, and have its radius equal to a given straight line.
21. A straight line of constant length remains always parallel to itself, while one of its extremities describes the circumference of a circle. Find the locus of the other extremity.
22. One vertex of an equilateral triangle is fixed, another is taken anywhere on a given straight line; show that the locus of the third vertex is a pair of straight lines.
23. One vertex of an equilateral triangle is fixed, another is on a given circle, find the locus of the third vertex.
24. O is a given point, P any point on a given circle; PO is produced to Q, so that OQ equals OP. Find the locus of Q.
25. Given the base and the difference of the sides of a triangle, find the locus of the feet of the perpendiculars from the ends of the base to the bisector of the vertical angle.
26. Given the base and the sum of the sides, find the locus of the feet of the perpendiculars from the ends of the base to the bisector of the exterior vertical angle.

27. $\angle BAC$ is a fixed angle of a triangle; find the locus of the middle point of the base BC , when (1) the sum, (2) the difference of the sides AB, AC is given.
28. Find the locus of a point, such that the difference of the squares of its distances from two fixed points is equal to a given square.
29. ABC is a triangle; find the locus of a point P , such that the sum of the triangles PAB, PBC is constant.
30. If AB, CD be two lines given in position and magnitude, and if a point P moves so that the sum of the areas of the triangles ABP, CDP is given, the locus of P is a straight line.
31. Find the locus of a point the sum of whose perpendicular distances from two given intersecting straight lines may be equal to a given length.
32. AB, CD are two given finite straight lines, find the locus of a point P which is such that the triangle APB is equal to the triangle CPD .
33. Find the locus of the middle point of a line of given length, which has its extremities on two given lines at right angles.
34. Find the locus of the vertices of all triangles on a given base AB , such that the square on the side terminated at A may exceed the square on the side terminated at B , by a given square.
35. O is a fixed point, and P any point on a given straight line; PO is produced to Q so that OQ is equal to OP . Find the locus of Q .
36. Straight lines are drawn from a given fixed point to the circumference of a given fixed circle, and are bisected: find the locus of their middle points.
37. ABC is a triangle; find the locus of a point O such that the sum of the areas OAB, OBC, OCA is constant and greater than the area of ABC .
38. Three sides and a diagonal of a quadrilateral are given; find the locus of (1) the undetermined vertex, (2) the middle point of the second diagonal, (3) the middle point of the straight line which joins the middle points of the two diagonals.
39. If points P and Q be taken on the sides AB, AC respectively of the triangle ABC , making the angle APQ equal to C , and the angle AQP equal to B ; prove that the locus of the middle point of PQ is a straight line through A , and that the three such lines through the vertices of the triangle meet in a point.



EUCLID'S ELEMENTS

BOOK II.

A rectangle is said to be **contained** by two of its adjacent sides.

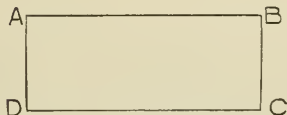

The abbreviation 'rect. AB.BC' means the rectangle whose adjacent sides are equal respectively to AB and BC.

A rectangle is frequently named by means of letters placed at two opposite vertices. Thus, the rectangle in the figure is called the rectangle AC, or BD.

Proofs of three elementary propositions called A, B and C are given. These help to simplify and shorten the proofs of the first ten propositions. Euclid gave no reference to former propositions, and frequently assumed such results as those contained in Props. A, B, C.

Algebraical identities. In mensuration, the area of a rectangle is measured by the product of the number of units of length in two adjacent sides. Representing the lengths of the lines by letters, and expressing the equality of areas indicated by the proposition, an algebraical identity is derived corresponding to each of the first ten theorems of this book.

PROPOSITION A. THEOREM.

A parallelogram which has one angle a right angle, is a rectangle: that is, it has all its angles right angles.

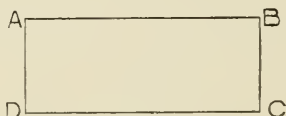

Let ABCD be a $\parallel m$, of which the $\angle ABC$ is a right angle.

It is required to prove that ABCD is a rectangle.

Proof. $\because AD \parallel BC$, and st. line AB cuts them,

\therefore interior \angle s DAB, ABC together = two rt. \angle s. *I. 29.*

But $\angle ABC =$ a rt. \angle , *Hyp.*

$\therefore \angle DAB =$ a rt. \angle .

Similarly it may be shown that

\angle s ADC, BCD are rt. \angle s.

\therefore ABCD is a rectangle. *Def. of rect.*

PROPOSITION B. THEOREM.

If two adjacent sides of a rectangle are equal, the rectangle is a square.

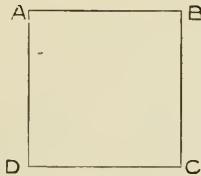

Let ABCD be a rectangle, of which
the side AB = the side AD.

It is required to prove rect. ABCD a square.

Proof. ∵ the opposite sides of a \parallel m are equal, *I. 34.*

∴ AB = DC.

And similarly AD = BC.

But AB = AD.

Hyp.

∴ BC = DC.

And ∴ the sides AB, BC, CD, DA are all equal ; and the
angles of the figure are right angles,

∴ ABCD is a square. *Def. of sq.*

PROPOSITION C. THEOREM.

If two adjacent sides of one rectangle are equal to two adjacent sides of another, each to each, the rectangles are equal in area.

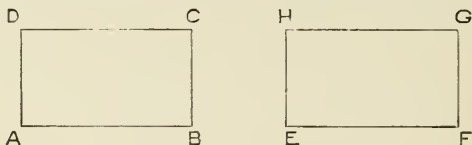

Let $ABCD$ and $EFGH$ be two rectangles,
having $AB = EF$, and $BC = FG$.

It is required to prove that the rectangles are equal.

Proof. If rect. $ABCD$ be applied to rect. $EFGH$,
so that AB coincides with EF ,
then $\therefore \angle ABC = \angle EFG$,
 $\therefore BC$ will fall on FG ;
and $\therefore BC = FG$,
 $\therefore C$ will coincide with G .

And, similarly, CD will coincide with GH ,
and DA with HE .

\therefore rect. $ABCD$ coincides with rect. $EFGH$,
and \therefore rect. $ABCD =$ rect. $EFGH$.

PROPOSITION I. THEOREM.

If there be two straight lines, one of which is divided into any number of parts, the rectangle contained by the two straight lines is equal to the sum of the rectangles contained by the undivided line and the several parts of the divided line.

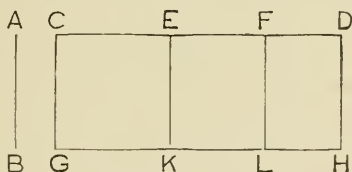

Let AB and CD be the two st. lines, and let CD be divided into any number of parts CE , EF , FD .

It is required to prove

rect. $AB.CD = \text{rect. } AB.CE + \text{rect. } AB.EF + \text{rect. } AB.FD$.

Construction. From C draw $CG \perp CD$, and make $CG = AB$.

Through G draw $GKLH \parallel CD$, and through E , F , D draw EK , FL , DH , each $\parallel CG$. *I. 31.*

Proof. Then all the figures CH , CK , EL , FH are rectangles. *II. A.*

Now $\because CG = AB$,

$\therefore \text{rect. } CH = \text{rect. } AB.CD$.

And $\because EK = \text{opp. side } CG$, and $FL = \text{opp. side } CG$, *I. 34.*

$\therefore EK = FL = AB$;

and $\therefore \text{rect. } CK = \text{rect. } AB.CE$,

$\text{rect. } EL = \text{rect. } AB.EF$,

and $\text{rect. } FH = \text{rect. } AB.FD$.

Now $\text{rect. } AB.CD = \text{rect. } CH$

$= \text{rect. } CK + \text{rect. } EL + \text{rect. } FH$

$= \text{rect. } AB.CE + \text{rect. } AB.EF + \text{rect. } AB.FD$.

Corresponding algebraical identity. $a(b + c + d) = ab + ac + ad$.

PROPOSITION 2. THEOREM.

If a straight line be divided into any two parts, the square on the whole line is equal to the sum of the rectangles contained by the whole line and each of the parts.

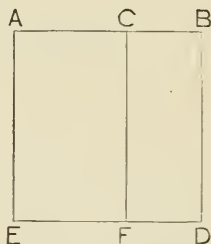

Let the st. line AB be divided into any two parts at the pt. C.

It is required to prove

$$\text{sq. on } AB = \text{rect. } AB.AC + \text{rect. } AB.CB.$$

Construction. On AB describe the sq. ABDE. *I.* 46.

Through C draw CF \parallel AE, meeting ED in F. *I.* 31.

Proof. Then the figs. AD, AF, CD are rectangles. *II.* A.

Now \because AE = AB, *Def. of sq.*

\therefore rect. AF = rect. AB.AC ;

And \because BD = AB, *Def. of sq.*

\therefore rect. CD = rect. AB.CB.

Now, sq. on AB = rect. AF + rect. CD

= rect. AB.AC + rect. AB.CB.

AN ALTERNATIVE PROOF OF PROPOSITION 2.

A _____ C _____ B _____ D _____ E

Let the st. line AB be divided into any two parts at the pt. C.
It is required to prove

$$\text{sq. on AB} = \text{rect. AB.AC} + \text{rect. AB.CB.}$$

Construction. Take another st. line, DE, = AB.

Proof. Now, $\text{rect. DE.AB} = \text{rect. DE.AC} + \text{rect. DE.CB.}$ // 1.

But $\text{rect. DE.AB} = \text{sq. on AB,}$

$\text{rect. DE.AC} = \text{rect. AB.AC,}$

and $\text{rect. DE.CB} = \text{rect. AB.CB,}$

$\therefore \text{sq. on AB} = \text{rect. AB.AC} + \text{rect. AB.CB.}$

Corresponding algebraical identity. $(a + b)^2 = (a + b) a + (a + b) b.$

PROPOSITION 3. THEOREM.

If a straight line be divided into any two parts, the rectangle contained by the whole line and one part is equal to the sum of the square on that part, and the rectangle contained by the parts.

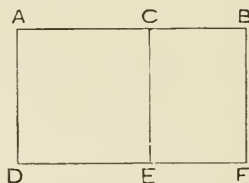

Let the st. line AB be divided into any two parts at the pt. C.

It is required to prove

$$\text{rect. } AB.AC = \text{sq. on } AC + \text{rect. } AC.CB.$$

Construction. On AC describe the sq. ADEC. *I* 46.

Through B draw BF \parallel CE, or AD, *I* 31.
meeting DE produced, in F.

Proof. Then figs. AF, AE, CF are rectangles. *II*. A.

Also BF = opp. side CE, *I*. 34.

and AC = CE,

\therefore BF = AC.

\therefore rect. AF = rect. AB.AC,

and rect. CF = rect. AC.CB.

Now, rect. AB.AC = rect. AF

= rect. AE + rect. CF

= sq. on AC + rect. AC.CB.

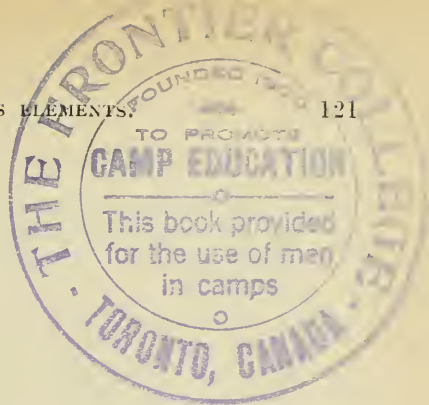

AN ALTERNATIVE PROOF OF PROPOSITION 3.



Let the st. line AB be divided into any two parts at the pt. C.
It is required to prove

$$\text{rect. AB.AC} = \text{sq. on AC} + \text{rect. AC.CB.}$$

Construction. Take another st. line, DE, = AC.

Proof. Now, $\text{rect. DE.AB} = \text{rect. DE.AC} + \text{rect. DE.CB. II. 1.}$

$$\text{But rect. DE.AB} = \text{rect. AB.AC,}$$

$$\text{rect. DE.AC} = \text{sq. on AC,}$$

$$\text{and rect. DE.CB} = \text{rect. AC.CB,}$$

$$\therefore \text{rect. AB.AC} = \text{sq. on AC} + \text{rect. AC.CB.}$$

Corresponding algebraical identity. $(a + b)a = a^2 + ab.$

PROPOSITION 4. THEOREM.

If a straight line be divided into any two parts the square on the whole line is equal to the sum of the squares on the parts and twice the rectangle contained by the parts.

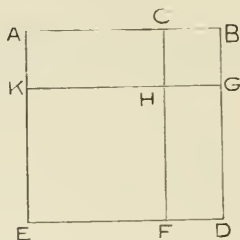

Let the st. line AB be divided into any two parts at the pt. C.

It is required to prove

sq. on AB = sq. on AC + sq. on CB + twice rect. AC.CB.

Construction. On AB describe the sq. ABDE. *I.* 46.

From BD cut off the part BG = CB.

Through C draw CHF \parallel AE, or BD, meeting ED in F; and through G draw GHK \parallel AB or ED, meeting AE in K.

Proof. Then figs. AH, CG, KF, HD are rectangles. *II.* A.

Now \because BG = BC, \therefore rect. CG = sq. on CB. *II.* B.

\because AK = opp. side BG, and BG = CB, \therefore AK = CB,

\therefore rect. AH = rect. AC.CB.

\because AE = AB, and part AK = part CB,

\therefore remainder KE = remainder AC.

And \because KH = opp. side AC, \therefore KE = KH. *I.* 34.

\therefore rect. KF. = sq. on KH = sq. on AC;

And \because HF = opp. side KE = AC,

and HG = opp. side CB,

\therefore rect. HD = rect. AC.CB.

Now sq. on AB

= rect. KF + rect. CG + rect. AH + rect. HD

= sq. on AC + sq. on CB + twice rect. AC.CB.

Digitized by Microsoft®

AN ALTERNATIVE PROOF OF PROPOSITION 4.

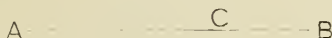

Let the st. line AB be divided into any two parts at the pt. C.
It is required to prove

sq. on AB = sq. on AC + sq. on CB + twice rect. AC.CB.

Proof. Now sq. on AB = rect. AB.AC + rect. AB.CB. // 2.

But rect. AB.AC. = sq. on AC + rect. AC.CB, // 1.

and rect. AB.CB = sq. on CB + rect. AC.CB.

\therefore sq. on AB = sq. on AC + sq. on CB + twice rect. AC.CB.

Corresponding algebraical identity. $(a + b)^2 = a^2 + b^2 + 2ab$.

EXERCISES.

1. A, B, C, D are four points in order in a straight line. Show that
rect. AB.CD + rect. BC.AD = rect. AC.BD.
2. There are two straight lines, each of which is divided into any
number of parts. Show that the rectangle contained by the
two lines is equal to the sum of the rectangles contained by
all the parts of the one taken separately with all the parts of
the other.
3. Prove that the square on a straight line is equal to four times the
square on half the line.
4. In a right-angled triangle ABC, a perpendicular is drawn from
the right angle A to meet the hypotenuse BC in D.
Prove : (a) rect. BD.DC = sq. on AD.
(b) rect. BC.CD = sq. on AC.
5. A straight line AB is divided into two parts at C, and twice the
rectangle contained by AC and CB is equal to the sum of the
squares on AC and CB. Show that AB is bisected at C.

PROPOSITION 5. THEOREM.

If a straight line be divided into two equal parts and also into two unequal parts, the sum of the rectangle contained by the unequal parts and the square on the line between the points of section, is equal to the square on half the line.

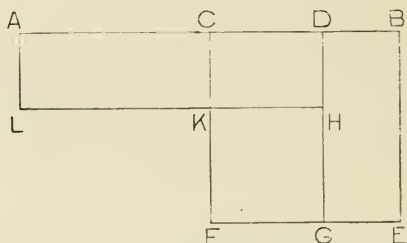

Let the st. line AB be divided into two equal parts at C and two unequal parts at D .

It is required to prove

$$\text{rect. } AD.DB + \text{sq. on } CD = \text{sq. on } CB.$$

Construction. On CB describe the square $CBEF$. *I. 46.*

Through D draw $DG \parallel CF$, or BE , *I. 31.*
meeting FE in G .

From DG cut off $DH = DB$.

Through H draw $HL \parallel AD$, meeting CF in K .

Through A draw $AL \parallel DH$.

Proof. All the \parallel ms in the figure are rectangles. *II. A.*

Now $\because DG = \text{opp. side } CF$, and $CB = CF$,
 $\therefore DG = CB$.

And part $DH = \text{part } DB$.

\therefore remainder $HG = \text{remainder } CD$.

But $HK = \text{opp. side } CD$, *I. 34.*
 $\therefore HG = HK$.

\therefore rect. $KG = \text{sq. on } KH = \text{sq. on } CD$. *II. B.*

And $\because DH = DB$,

\therefore rect. $AH = \text{rect. } AD.DB$.

And $\because AC = BE$, and $CK = \text{opp. side } DH = DB$,

\therefore rect. $AK = \text{rect. } DE$. *II. C.*

$$\begin{aligned}
 \text{Now rect. AD.DB} + \text{sq. on CD} &= \text{rect. AH} + \text{rect. KG} \\
 &= \text{rect. AK} + \text{rect. CH} + \text{rect. KG} \\
 &= \text{rect. DE} + \text{rect. CH} + \text{rect. KG} \\
 &= \text{rect. CE} \\
 &= \text{sq. on CB.}
 \end{aligned}$$

AN ALTERNATIVE PROOF OF PROPOSITION 5.



Let the st. line AB be divided into two equal parts at C, and two unequal parts at D.

It is required to prove

$$\text{rect. AD.DB} + \text{sq. on CD} = \text{sq. on CB.}$$

Proof. Now $\text{rect. AD.DB} = \text{rect. AC.DB} + \text{rect. CD.DB}$ *II. 1.*
 $= \text{rect. CB.DB} + \text{rect. CD.DB.}$

$$\begin{aligned}
 \therefore \text{rect. AD.DB} + \text{sq. on CD} \\
 &= \text{rect. CB.DB} + \text{rect. CD.DB} + \text{sq. on CD} \\
 &= \text{rect. CB.DB} + \text{rect. CB.CD} && \text{II. 3.} \\
 &= \text{sq. on CB.} && \text{II. 2.}
 \end{aligned}$$

Corresponding algebraical identity. $(a+b)(a-b) + b^2 = a^2.$

EXERCISES.

1. Divide a given straight line into two parts such that the rectangle contained by them is the greatest possible.
2. Divide a given straight line into two parts such that the sum of the squares on the parts is the least possible.
3. Divide a given straight line into two parts such that the rectangle contained by the parts may be equal to a given square.
4. Show that a rectangle of given perimeter has greatest area when it is a square.
5. The rectangle contained by any two straight lines is equal to the square on half their sum diminished by the square on half their difference.

PROPOSITION 6. THEOREM

If a straight line be bisected and produced to any point, the sum of the rectangle contained by the whole line thus produced and the part of it produced, and the square on half the line bisected, is equal to the square on the line which is made up of the half and the part produced.

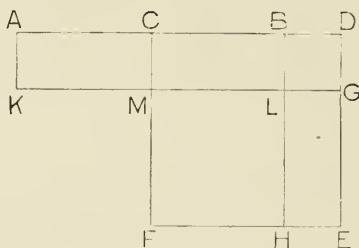

Let the st. line AB be bisected at C and produced to D.
It is required to prove

rect. AD.DB + sq. on CB = sq. on CD.

Construction. On CD describe the sq. CDEF. *I. 46.*

Through B draw BLH \parallel CF or DE, and through A draw AK \parallel CF or DE.

From DE cut off DG = DB.

Through G draw GLMK \parallel AD, meeting CF in M.

Proof. All the \parallel ms in the figure are rectangles. *II. A.*

Now \because DG = DB, \therefore rect. AG = rect. AD.DB.

And \because CD = DE, and part BD = part DG,

\therefore remainder CB = remainder GE.

But AC = CB \therefore AC = GE.

Also AK = opp. side DG = BD = opp. side LG. *I. 34.*

\therefore rect. AM = rect. LE. *II. C.*

Again, LH = opp. side GE = CB = opp. side ML.

\therefore rect. MH = sq. on CB.

$$\begin{aligned}
 \text{Now, rect. AD.DB + sq. on CB} \\
 &= \text{rect. AG + rect. MH,} \\
 &= \text{rect. AM + rect. CG + rect. MH} \\
 &= \text{rect. LE + rect. CG + rect. MH} \\
 &= \text{rect. CE} \\
 &= \text{sq. on CD.}
 \end{aligned}$$

AN ALTERNATIVE PROOF OF PROPOSITION 6.

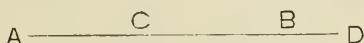

Let the st. line AB be bisected at C, and produced to D.
It is required to prove

$$\text{rect. AD.DB + sq. on CB = sq. on CD.}$$

Proof. Now rect. AD.DB

$$= \text{rect. AC.BD + rect. CB.BD + sq. on BD} \quad \text{II. 1.}$$

$$= \text{twice rect. CB.BD + sq. on BD.}$$

\therefore rect. AD.DB + sq. on CB

$$= \text{sq. on CB + sq. on BD + twice rect. CB.BD}$$

$$= \text{sq. on CD.} \quad \text{II. 4.}$$

Corresponding algebraical identity. $(a + b)(b - a) + a^2 = b^2.$

EXERCISES.

1. The difference of the squares on two given straight lines is equal to the rectangle contained by the sum and the difference of the lines.
2. The difference of the squares on two sides of a triangle is equal to twice the rectangle contained by the base and the intercept between the middle point of the base and the foot of the perpendicular drawn from the vertical angle to the base.

PROPOSITION 7. THEOREM.

If a straight line be divided into any two parts, the sum of the square on the whole line and on one of the parts, is equal to the sum of twice the rectangle contained by the whole line and that part, and the square on the other part.

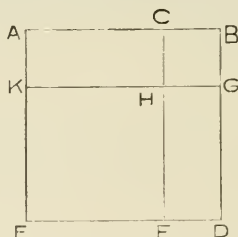

Let the straight line AB be divided into any two parts at C.

It is required to prove

sq. on AB + sq. on CB = twice rect. AB.CB + sq. on AC.

Construction. On AB describe the sq. ABDE. *I.* 46.

Through C draw CHF \parallel AE or BD, *I.* 31.
meeting ED in F.

From BD cut off BG = CB,
and through G draw GHK \parallel AB, or ED
meeting AE in K.

Proof. All the \parallel ms in the figure are rectangles. *II.* A.

And \because BC = BG, \therefore CG = sq. on CB.

\because BD = AB, and part BG = part CB,

\therefore remainder GD = remainder AC.

\because KE = opp. side GD, \therefore KE = AC. *I.* 34.

Also KH = opp. side AC.

\therefore rect. KF = sq. on AC.

\because BD = AB, and BC = BG.

\therefore rect. CD = rect. AG = rect. AB.CB. *II.* C.

Now sq. on AB + sq. on CB

= rect. AG + rect. HD + rect. CG + rect. KF

= rect. AG + rect. CD + rect. KF

= twice rect. AB.CB + sq. on AC.

AN ALTERNATIVE PROOF OF PROPOSITION 7.

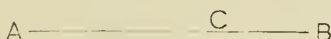

Let the st. line AB be divided into any two parts at C.

It is required to prove

sq. on AB + sq. on BC = twice rect. AB.BC + sq. on AC.

Proof. Now, sq. on AB = rect. AB.AC + rect. AB.BC II. 2.

= rect. AC.CB + sq. on AC + rect. AB.BC. II. 3.

∴ sq. on AB + sq. on BC

= rect. AC.CB + sq. on BC + sq. on AC + rect. AB.BC

= rect. AB.BC + sq. on AC + rect. AB.BC

= twice rect. AB.BC + sq. on AC.

Corresponding algebraical identity. $(a + b)^2 + b^2 = 2(a + b)b + a^2$.

EXERCISES.

1. Prove that the square on the difference of two straight lines is less than the sum of the squares on the lines by twice the rectangle contained by them.
2. If the straight line AB is divided in C so that the square on AC is equal to the rectangle AB.BC, show that the sum of the squares on AB and CB is equal to three times the square on AC.

PROPOSITION 8. THEOREM.

If a straight line be divided into any two parts, the sum of four times the rectangle contained by the whole line and one of the parts and the square on the other part, is equal to the square on the line made up of the whole and that part.

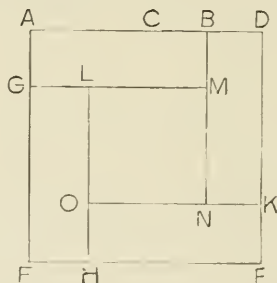

Let the st. line AB be divided into any two parts at C , and let it be produced to D , making $BD = BC$.

It is required to prove

four times rect. $AB \cdot BC$ + sq. on AC = sq. on AD .

Construction. On AD describe the sq. $ADEF$. *I. 46.*

And make AG, FH, EK , each = BC , or BD . *I. 3.*

Through G, H, K, B , draw

GLM, HOL, KNO, BMN , parallel respectively to the sides of the square.

Proof. Then all the \parallel ms in the figure are rectangles.

$\therefore GM =$ opp. side AB , and $GL =$ opp. side $FH = BC$,

\therefore remainder $LM =$ remainder AC .

Similarly LO may be shown = AC .

\therefore rect. $LN =$ sq. on AC .

Again, the four rectangles AM, DN, EO, FL are equal, and each = rect. $AB \cdot BC$, $\therefore AG = BC$.

Now, four times rect. $AB \cdot BC$ + sq. on AC

= the four rectangles + the sq. LN

= whole fig. AE

= sq. on AD .

AN ALTERNATIVE PROOF OF PROPOSITION 3.

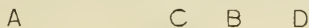

Let the st. line AB be divided into any two parts at C, and let it be produced to D, making $BD = BC$.

It is required to prove

four times rect. $AB \cdot BC$ + sq. on AC = sq. on AD.

Proof. Now, rect. $AB \cdot BC$ = rect. $AC \cdot CB$ + sq. on CB, // 1.
and twice rect. $AB \cdot BC$ = twice rect. $AC \cdot CB$ + twice sq. on CB.
= rect. $AC \cdot CD$ + twice sq. on CB.

And four times rect. $AB \cdot BC$

= twice rect. $AC \cdot CD$ + four times sq. on CB

= twice rect. $AC \cdot CD$ + square on CD.

\therefore four times rect. $AB \cdot BC$ + sq. on AC

= sq. on AC + sq. on CD + twice rect. $AC \cdot CD$.

= sq. on AD.

// 4.

Corresponding algebraical identity. $4(a+b)b + a^2 = (a+2b)^2$.

EXERCISES.

1. Prove that the square on the sum of two straight lines is greater than the square on their difference, by four times the rectangle contained by the lines.
2. If a straight line be divided into five equal parts, show that the square on the whole line is equal to the sum of the squares on the lines made up respectively of three and four of the equal parts.

PROPOSITION 9. THEOREM.

If a straight line be divided into two equal, and also into two unequal parts, the sum of the squares on the unequal parts is equal to twice the square on half the line and the square on the line between the points of section.

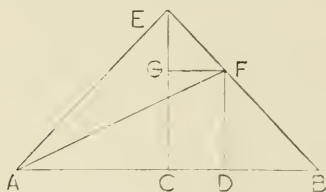

Let the st. line AB be divided into two equal parts at C, and two unequal parts at D.

It is required to prove

$$\text{sq. on AD} + \text{sq. on DB} = \text{twice sq. on AC} \\ + \text{twice sq. on CD.}$$

Construction. Draw $CE \perp AB$, and $= AC$, or CB . *I. 11.*

Join AE and BE.

Draw $DF \perp AB$, meeting BE in F. *I. 11.*

Draw $FG \parallel AB$, meeting CE in G. *I. 31.*

Join AF.

Proof. Now, in the isosceles $\triangle ACE$,

$$\therefore \angle ACE = \text{a rt. } \angle,$$

$$\text{and } \angle CAE = \angle CEA, \quad \text{I. 5.}$$

$$\therefore \angle CAE, \text{ and also } \angle CEA, = \text{half a rt. } \angle. \quad \text{I. 32.}$$

Similarly, each of \angle s CBE, CEB = half a rt. \angle .

$$\therefore \text{whole } \angle AEB = \text{a rt. } \angle.$$

Again \therefore exterior $\angle EGF =$ interior opposite $\angle ECB$, *I. 29.*

$$\therefore \angle EGF = \text{a rt. } \angle.$$

But $\angle FEG =$ half a rt. \angle ;

$$\therefore \angle EFG = \text{half a rt. } \angle = \angle FEG. \quad \text{I. 32.}$$

$$\therefore EG = GF. \quad \text{I. 6.}$$

$$\text{Also } GF = \text{opp. side } CD. \quad \text{I. 34.}$$

Again $\because \angle FDB =$ a rt. \angle ,
 and $\angle DBF =$ half a rt. \angle ,
 $\therefore \angle DFB =$ half a rt. $\angle = \angle DBF$,
 and $\therefore DF = DB$. I. 6.

Now, sq. on AD + sq. on DB
 = sq. on AD + sq. on DF
 = sq. on AF I. 47.
 = sq. on AE + sq. on EF
 = sq. on AC + sq. on CE + sq. on GF + sq. on GE
 = twice sq. on AC + twice sq. on CD.

AN ALTERNATIVE PROOF OF PROPOSITION 9.

A C D B

Let the st. line AB be divided into two equal parts at C, and two unequal parts at D.

It is required to prove

sq. on AD + sq. on DB = twice sq. on AC + twice sq. on CD.

Proof. Now sq. on AD = sq. on AC + sq. on CD
 + twice rect. AC, CD, II. 4.

and sq. on CB + sq. on DB = twice rect. CB, BD + sq. on CD. II. 7.

\therefore sq. on AD + sq. on DB + sq. on CB
 = sq. on AC + twice rect. AC, CD + twice rect. CB, BD
 + twice sq. on CD
 = sq. on AC + twice rect. CB, CD + twice rect. CB, BD
 + twice sq. on CD.
 = sq. on AC + twice sq. on CD + twice sq. on CB.

\therefore sq. on AD + sq. on DB
 = twice sq. on AC + twice sq. on CD.

Corresponding algebraical identity $(a + b)^2 + (a - b)^2 = 2a^2 + 2b^2$.

EXERCISES.

1. Divide a given straight line into two parts such that the sum of the squares on the parts is the least possible.
2. If a straight line be divided into two equal parts and also into two unequal parts, the sum of the squares on the unequal parts is equal to twice the rectangle contained by the unequal parts, together with four times the square on the line between the points of section.

PROPOSITION 10. THEOREM.

If a straight line be bisected and produced to any point, the sum of the square on the whole line produced and the square on the part of it produced, is equal to twice the sum of the square on half the line bisected and of the square on the line made up of the half and the part produced.

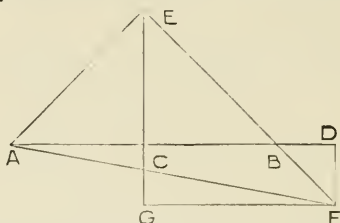

Let the st. line AB be bisected at C and produced to D.

It is required to prove

$$\text{sq. on AD} + \text{sq. on BD.} = \text{twice sq. on AC} + \text{twice sq. on CD.}$$

Construction. Draw $CE \perp AB$, and $= AC$, or CB . *I. 11.*
Join AE and BE .

Draw $DF \perp AB$, meeting EB produced in F .

Draw $FG \parallel AB$, meeting EC produced in G .

Join AF .

Proof. Now, in the isosceles $\triangle ACE$,

$$\therefore \angle ACE = \text{a rt. } \angle,$$

$$\text{and } \angle CAE = \angle CEA, \quad \text{I. 5.}$$

$$\therefore \angle CAE, \text{ and also } \angle CEA, = \text{half a rt. } \angle. \quad \text{I. 32.}$$

Similarly, each of \angle s CBE , $CEB = \text{half a rt. } \angle$.

$$\therefore \text{whole } \angle AEB = \text{a rt. } \angle.$$

Again, \therefore exterior $\angle ECB =$ interior opposite $\angle EGF$, *I. 29.*

$$\therefore \angle EGF = \text{a rt. } \angle.$$

$$\text{But } \angle FEG = \text{half a rt. } \angle.$$

$$\therefore \angle EFG = \text{half a rt. } \angle = \angle FEG.$$

$$\therefore GE = GF. \quad \text{I. 6.}$$

$$\text{Also } GF = \text{opp. side } CD. \quad \text{I. 34.}$$

Again, $\therefore \angle FDB = \text{a rt. } \angle$,
 and $\angle DBF = \text{vertically opp. } \angle CBE = \text{half a rt. } \angle$,
 $\therefore \angle DFB = \text{half a rt. } \angle = \angle DBF$,
 and $\therefore DF = DB$.

Now, sq. on AD + sq. on BD
 = sq. on AD + sq. on DF
 = sq. on AF I. 47.
 = sq. on AE + sq. on EF
 = sq. on AC + sq. on CE + sq. on GF + sq. on GE
 = twice sq. on AC + twice sq. on CD.

AN ALTERNATIVE PROOF OF PROPOSITION 10.



Let the st. line AB be bisected at C, and produced to D.
 It is required to prove

sq. on AD + sq. on BD = twice sq. on AC + twice sq. on CD.

Proof. Now sq. on AD

= sq. on AC + sq. on CD + twice rect. AC.CD II. 4.

= sq. on CB + sq. on CD + twice rect. BC.CD.

But sq. on CB + sq. on CD = twice rect. BC.CD + sq. on BD. II. 7.

\therefore sq. on AD = four times rect. BC.CD + sq. on BD.

\therefore sq. on AD + sq. on DB

= four times rect. BC.CD + twice sq. on BD

= twice sq. on BC + twice sq. on CD II. 7.

= twice sq. on AC + twice sq. on CD.

Corresponding algebraical identity. $(a + b)^2 + (b - a)^2 = 2a^2 + 2b^2$.

EXERCISES.

1. The sum of the squares on the sum and on the difference of two given straight lines is equal to twice the sum of the squares on the lines.
2. Given the sum or the difference of two straight lines, and the sum of their squares, find the lines.
3. Show that the sum of the squares on any two straight lines is equal to twice the square on half the sum of the lines, together with twice the square on half their difference.

PROPOSITION II. PROBLEM.

To divide a given straight line into two parts, so that the rectangle contained by the whole line and one part shall be equal to the square on the other part; that is, to divide the line in medial section.

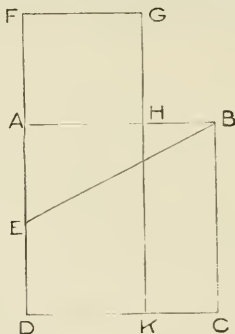

Let AB be the given st. line.

It is required to divide AB in medial section.

Construction. On AB describe the sq. $ABCD$. *I. 46.*

Bisect AD in E , and join EB .

Produce EA to F , making $EF = EB$.

Make $AH = AF$.

Then AB shall be divided at H , so that rect. $AB.BH$
= sq. on AH .

Through F draw $FG \parallel AB$, and through H
draw $GHK \parallel FD$.

Proof. Now, rect. FH is sq. on AH . *II. B.*

And $\because DA$ is bisected at E , and produced to F ,

\therefore rect. $DF.FA +$ sq. on $AE =$ sq. on EF *II. 5.*

= sq. on EB

= sq. on $AB +$ sq. on AE . *I. 47.*

Taking away common part, sq. on AE ,

\therefore rect. $DF.FA =$ sq. on AB ,

that is, rect. $FK =$ sq. AC .

Taking away common part, rect. AK ,

\therefore rect. $FH =$ rect. HC .

But rect. $FH =$ sq. on AH ,

and rect. $HC =$ rect. $BC.BH =$ rect. $AB.BH$.

\therefore rect. $AB.BH =$ sq. on AH .

To produce a given straight line so that the rectangle contained by the given line and the whole line produced shall be equal to the square on the part produced.

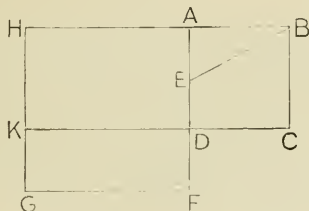

Let AB be the given st. line.

Construction. On AB describe the sq. ABCD.

Bisect AD in E, and join EB.

Produce AD to F, making EF = EB.

On AF describe sq. AFGH.

Evidently H will lie in BA produced.

Then will rect. AB.BH = sq. on AH.

Produce CD to meet GH in K.

Proof. ∵ AD is bisected in E, and produced to F,
∴ rect. AF.FD + sq. on DE = sq. on EF

$$= \text{sq. on EB}$$

$$= \text{sq. on AE} + \text{sq. on AB.}$$

But sq. on DE = sq. on AE.

∴ rect. AF.FD = sq. on AB.

∴ rect. FK = sq. AC.

To each add rect. AK.

∴ rect. FH = rect. HC,

that is, sq. on AH = rect. AB.BH.

EXERCISES.

1. If the straight line AB is divided at H as in *II. 11*, prove (*a*) that the sum of the squares on AB and AH is equal to three times the square on AH, (*b*) that the square on the sum of AB and BH is equal to five times the square on AH.
2. Produce a given straight line so that the rectangle contained by the whole line and the part produced may be equal to the square on the given line.

PROPOSITION 12. THEOREM.

In an obtuse-angled triangle, if a perpendicular be drawn from either of the acute angles to the opposite side produced, the square on the side subtending the obtuse angle is greater than the sum of the squares on the sides containing the obtuse angle, by twice the rectangle contained by the side, upon which, when produced, the perpendicular falls, and the straight line intercepted without the triangle between the perpendicular and the obtuse angle.

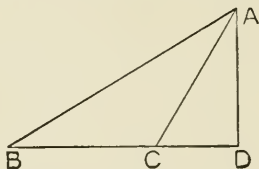

Let $\triangle ABC$ be an obtuse-angled \triangle , having $\angle ACB$ obtuse.

From A draw $AD \perp BC$ produced.

It is required to prove

$$\text{sq. on } AB = \text{sq. on } BC + \text{sq. on } CA \\ + \text{twice rect. } BC \cdot CD.$$

Proof. Now $\text{sq. on } BD = \text{sq. on } BC + \text{sq. on } CD \\ + \text{twice rect. } BC \cdot CD. \quad II. 4.$

To each add $\text{sq. on } DA.$

$$\therefore \text{sq. on } BD + \text{sq. on } DA = \text{sq. on } BC + \text{sq. on } CD \\ + \text{sq. on } DA + \text{twice rect. } BC \cdot CD.$$

But $\because \angle ADC$ is a right angle,

$$\therefore \text{sq. on } BD + \text{sq. on } DA = \text{sq. on } AB, \\ \text{and } \text{sq. on } CD + \text{sq. on } DA = \text{sq. on } CA. \quad I. 47.$$

$$\therefore \text{sq. on } AB = \text{sq. on } BC + \text{sq. on } CA \\ + \text{twice rect. } BC \cdot CD.$$

AN ALTERNATIVE PROOF OF PROPOSITION 12.

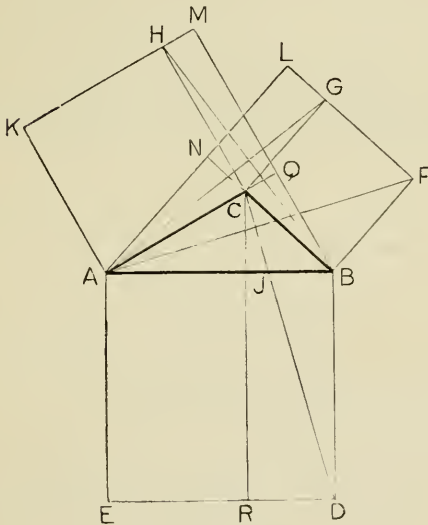

Let ABC be an obtuse-angled Δ , having $\angle ACB$ obtuse.
 Draw $AN \perp BC$ produced, and $BQ \perp AC$ produced.

It is required to prove

$$\text{sq. on } AB = \text{sq. on } AC + \text{sq. on } BC + \text{twice rect. } AC.CQ$$

(or twice rect. $BC.CN$).

Construction. Describe squares on the sides of the triangle and complete the rectangles CM, CL .

Draw $CR \perp ED$.

Join CD, AF, AG, BH .

Proof. Now $\Delta CBD = \Delta FBA$.

\therefore rect. $BR =$ rect. BL .

And similarly rect. $AR =$ rect. AM .

Again, $\Delta CBH = \Delta CGA$.

\therefore rect. $CM =$ rect. CL .

$$\therefore \text{sq. on } AB = \text{sq. on } AC + \text{sq. on } BC + \text{twice rect. } CM$$

$$= \text{sq. on } AC + \text{sq. on } BC + \text{twice rect. } AC.CQ.$$

PROPOSITION 13. THEOREM.

In every triangle the square on the side subtending an acute angle is less than the sum of the squares on the sides containing that angle, by twice the rectangle contained by either of these sides, and the line intercepted between the perpendicular let fall on it from the opposite angle and the acute angle.

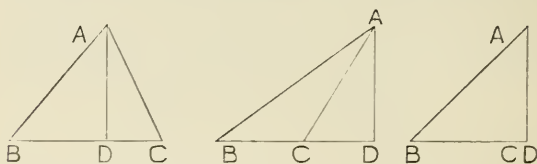

Let ABC be a triangle, having $\angle ABC$ acute, and let AD be drawn $\perp BC$, or BC produced.

It is required to prove

sq. on AB + sq. on BC = sq. on AC + twice rect. BC.BD.

Proof. In the two cases where C and D do not coincide,
 sq. on BC + sq. on BD = twice rect. BC.BD
 + sq. on DC. //. 7.

To each add sq. on DA.

\therefore sq. on BC + sq. on BD + sq. on DA
 = twice rect. BC.BD + sq. on DC + sq. on DA.

But $\because \angle s ADC, ADB$ are right angles,

\therefore sq. on BD + sq. on DA = sq. on AB,
 and sq. on DC + sq. on DA = sq. on AC. I. 47.

\therefore sq. on AB + sq. on BC
 = twice rect. BC.BD + sq. on AC.

In the case where C and D coincide,

twice the rect. BC.BD = twice sq. on BC.

\therefore sq. on AB + sq. on BC
 = sq. on AC + twice sq. on BC
 = sq. on AC + twice rect. BC.BD.

AN ALTERNATIVE PROOF OF PROPOSITION 13.

The proof is similar to that given as an alternative proof of Prop. 12. The figure is given below.

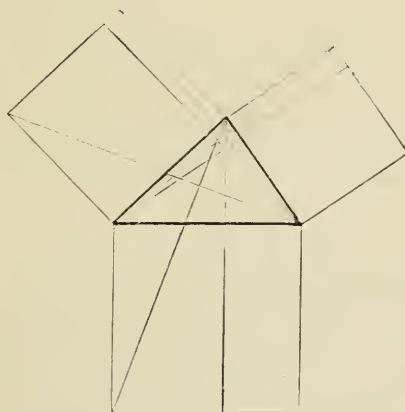

EXERCISES.

1. In any triangle the sum of the squares on the sides is equal to twice the square on half the base, together with twice the square on the line joining the vertex to the middle point of the base.
2. The sum of the squares on the sides of any parallelogram is equal to the sum of the squares on the diagonals.
3. The sum of the squares on the sides of any quadrilateral is greater than the sum of the squares on its diagonals by four times the square on the straight line joining the middle points of its diagonals.
4. If one angle of a triangle is double the angle of an equilateral triangle, the square on the opposite side is greater than the sum of the squares on the other two sides by the rectangle contained by these sides.

PROPOSITION 14. PROBLEM.

To describe a square which shall be equal to a given rectilineal figure.

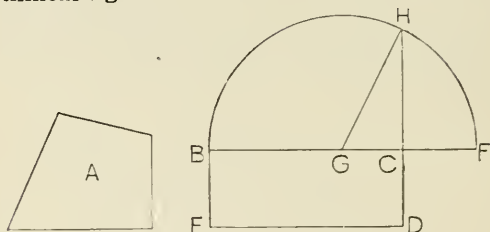

Let A be the given rectilineal figure.

It is required to describe a square = fig A.

Construction. Describe the rect. BCDE = fig. A. *I. 45.*

Then if $BC = CD$, BCDE is the square required.

But, if BC be not = CD ,

produce BC to F , making $CF = CD$.

Bisect BF in G .

With centre G , and radius GF , describe $\odot FHB$.

Produce DC , to meet the *Oce* in H .

The square on CH shall be the required square.

Join GH .

Proof. \because BF is divided into two equal parts at G , and two unequal parts at C ,

\therefore rect. $BC.CF$ + sq. on GC = sq. on GF . *II. 5.*

But sq. on GF = sq. on GH

= sq. on CH + sq. on GC . *I. 47.*

\therefore rect. $BC.CF$ + sq. on GC = sq. on CH + sq. on GC ,

and \therefore rect. $BC.CF$ = sq. on CH .

But rect. $BC.CF$ = fig. A.

\therefore sq. on CH = fig. A.

EXERCISES.

1. P is any point in the circumference of a circle, of which AB is any diameter. A perpendicular PQ is drawn from P to meet the diameter in Q. Prove that the square on PQ is equal to the rectangle AQ.QB.
2. Divide a given straight line so that the rectangle contained by the parts may be equal to the square on another given straight line.
3. Produce a given straight line so that the rectangle contained by the given line and the produced part may be equal to the square on a given straight line.

MISCELLANEOUS EXERCISES.

1. Find two straight lines, having given their sum or difference, and the area of the rectangle contained by them.
2. Find two straight lines, having given their sum or difference, and the difference of the squares described on them.
3. AB is divided into any two parts at C; D, E are the middle points of AC, CB respectively, show that the square on AE together with three times the square on EB is equal to the square on BD together with three times the square on DA.
4. The sum of the squares on two unequal straight lines is greater than twice the rectangle contained by the straight lines.
5. The sum of the squares on three unequal straight lines is greater than the sum of the rectangles contained by every two of the straight lines.
6. The sum of the squares on the sides of a triangle is less than twice the sum of the rectangles contained by every two of the sides.
7. The square on the sum of two unequal straight lines is greater than four times their rectangle.
8. If a line be cut in medial section, and a part be cut off from the greater part equal to the less, the greater part is also cut in medial section.
9. If a straight line be divided in medial section, the rectangle contained by the sum and the difference of the parts is equal to the rectangle contained by the parts.

10. In the figure of II. 11, if FG , DH , CB be produced they will meet in a point.
11. In the figure of II. 11, if the lines GB , FC , AK be drawn, they are parallel.
12. In the figure of II. 11, if CB and FG when produced meet in R , DR will be divided in medial section at H .
13. In the figure of II. 11, if DH be produced to meet BF at L , show that DL is at right angles to BF .
14. If BE and DH meet at O , show that AO is at right angles to DH .
15. PQ is divided in medial section at R ; show that the rectangle $PQ.PR$ together with the square on PR is equal to the square on PQ ; also that the rectangle $PQ.PR$ is equal to the sum of the rectangles contained by $PR.RQ$ and $PQ.QR$.
16. ABC is a right-angled triangle, A being the right angle. If AB equals $2AC$, and if AH be cut off of AB so that AH equals the difference between BC and AC , AB is divided in medial section at H .
17. If the square on the line CD , drawn from the angle C of an equilateral triangle ABC to a point D in the side AB produced, be equal to twice the square on AB ; prove that AD is divided in medial section at B .
18. Divide a given straight line into two parts, such that the square on one part may be equal to the rectangle contained by another given straight line and the other part.
19. The sum of the squares on two sides of a triangle is double the sum of the squares on half the base and on the median to the base.
20. The squares on the two equal sides of an isosceles triangle are together less than the sum of the squares on the two sides of any other triangle on the same base and between the same parallels.
21. A and B are two fixed points; find the position of another point P such that the sum of the squares on PA and PB may be the least possible.
22. The square on the base of an isosceles triangle is equal to twice the rectangle contained by either of the equal sides and the projection on it of the base.

23. ABC is a triangle having the sides AB and AC equal ; if AB is produced beyond the base to D so that BD is equal to AB, show that the square on CD is equal to the square on AB, together with twice the square on BC.
24. The sum of the squares on the sides of a parallelogram is equal to the sum of the squares on the diagonals.
25. The base of a triangle is given and is bisected by the centre of a given circle ; if the vertex be at any point of the circumference, show that the sum of the squares on the two sides of the triangle is invariable.
26. If in any quadrilateral two opposite sides be bisected, the sum of the squares on the other two sides, together with the sum of the squares on the diagonals, is equal to the sum of the squares on the bisected sides, together with four times the square on the line joining the points of section.
27. If a circle be described about the point of intersection of the diagonals of a parallelogram as a centre, show that the sum of the squares on the straight lines drawn from any point in its circumference to the four angular points of the parallelogram is constant.
28. Two circles are concentric. Prove that the sum of the squares of the distances from any point on the circumference of one of the circles to the ends of a diameter of the other is constant.
29. The squares on the sides of a quadrilateral are together greater than the squares on its diagonals by four times the square on the straight line joining the middle points of its diagonals.
30. In AB the diameter of a circle take two points C and D equally distant from the centre, and from any point E in the circumference draw EC, ED ; show that the squares on EC and ED are together equal to the squares on AC and AD.
31. In the hypotenuse of an isosceles right-angled triangle any point is taken and joined to the opposite vertex ; prove that twice the square on this straight line is equal to the sum of the squares on the segments of the hypotenuse.
32. In the hypotenuse produced of an isosceles right-angled triangle, any point is taken and joined to the opposite vertex ; prove that twice the square on this straight line is equal to the sum of the squares on the segments of the hypotenuse.

33. If from the hypotenuse of a right-angled triangle segments be cut off equal to the adjacent sides, the square on the middle segment thus formed is equal to twice the rectangle contained by the extreme segments.
34. In BC the base of a triangle take D such that the squares on AB and BD are together equal to the squares on AC and CD ; then the middle point of AD will be equally distant from B and C .
35. The square on any straight line drawn from the vertex of an isosceles triangle to the base is less than the square on a side of the triangle by the rectangle contained by the segments of the base.
36. C is any point equidistant from two fixed points A and B ; D any point in AB or AB produced; prove that the rectangle $AD \cdot DB$ is equal to the difference of the squares on CB , CD .
37. ABC is an isosceles triangle of which the angles at B and C are each double of A ; show that the square on AC is equal to the square on BC together with the rectangle contained by AC and BC .
38. If from one of the equal angles of an isosceles triangle a perpendicular be drawn to the opposite side, the square on that perpendicular is equal to the square on the line intercepted between it and the other equal angle together with twice the rectangle contained by the segments of the side.
39. If PQ be drawn parallel to the base BC of an isosceles triangle ABC , the difference of the squares on BQ , CQ is equal to the rectangle $BC \cdot PQ$.
40. A square $BDEC$ is described on the hypotenuse BC of a right-angled triangle ABC ; show that the squares on DA and AC are together equal to the squares on EA and AB .
41. ABC is a triangle in which C is a right angle, and DE is drawn from a point D in AC perpendicular to AB ; show that the rectangle $AB \cdot AE$ is equal to the rectangle $AC \cdot AD$.
42. ABC is a triangle having the angle at B a right angle; find in AB a point P such that the square on AC may exceed the sum of the squares on AP , PC , by half the square on AB .
43. The hypotenuse AB of a right-angled triangle ABC is trisected in the points D , E ; show that, if CD , CE be joined, the sum of the squares on the three sides of the triangle CDE is equal to two-thirds of the square on AB .

44. If DF and EK be joined, in figure I, 47, show that the difference of the squares on DF and EK is three times the difference of the squares on AB and AC .
45. Describe a right-angled triangle such that the rectangle contained by the hypotenuse and one of the sides is equal to the square on the other side.
46. If a straight line be drawn through one of the angles of an equilateral triangle to meet the opposite side produced, so that the rectangle contained by the whole straight line thus produced and the part of it produced is equal to the square on the side of the triangle, show that the square on the straight line so drawn will be double the square on a side of the triangle.
47. In a triangle whose vertical angle is a right angle a straight line is drawn from the vertex perpendicular to the base: show that the square on this perpendicular is equal to the rectangle contained by the segments of the base.
48. From one angle of a triangle a perpendicular is drawn to the opposite side, and the square on the perpendicular is equal to the rectangle contained by the segments of the opposite side. Show that the triangle must be right-angled.
49. In any quadrilateral the squares on the diagonals are together equal to twice the sum of the squares on the straight lines joining the middle points of opposite sides.
50. Find a point P in the plane of the triangle ABC , such that the squares of AP , BP , CP may be the least possible.
51. If one angle of a triangle be two-thirds of a right angle, the square on the opposite side is less than the sum of the squares containing that angle by the rectangle contained by these sides.
52. In a triangle whose vertical angle is a right angle a straight line is drawn from the vertex perpendicular to the base: show that the square on either of the sides adjacent to the right angle is equal to the rectangle contained by the base and the segment of it adjacent to that side.
53. If squares be described on the three sides of any triangle, and the adjacent angular points of the squares joined, the sum of the squares on the three joining lines is equal to three times the sum of the squares on the sides of the triangle.
54. In a triangle ABC the angles B and C are acute: if E and F be the points where perpendiculars from the opposite angles meet the sides AC , AB , show that the square on BC is equal to the rectangle $AB \cdot BF$, together with the rectangle $AC \cdot CE$.

55. Show that the sum of the squares on the three medians of a triangle is equal to three-fourths of the sum of the squares on the sides of a triangle.
56. The sum of the squares on the three straight lines joining the centroid of a triangle to its vertices is equal to one-third the sum of the squares on the sides of the triangle.
57. Divide a given straight line into two parts so that the rectangle contained by them may be equal to a given rectangle not greater than the square on half the given straight line.
58. Divide a given straight line into two parts such that the rectangle contained by the whole line and one of the parts may be four times the square on the other part.
59. Divide a given straight line into two parts so that the rectangle contained by the parts shall be equal to the rectangle contained by the whole line and the difference of the parts.
60. Divide a given straight line into two parts such that the sum of their squares may be equal to a given square.
61. Divide a given straight line into two parts so that the squares on the whole line and on one of the parts may be together double of the square on the other part.
62. Divide a given straight line into two parts so that the square on one part may be double the rectangle contained by the whole line and the other part.
63. Produce a given straight line so that the rectangle contained by the whole line thus produced, and the part produced, shall be equal to the square on half the given straight line.
64. Produce one side of a given triangle so that the rectangle contained by this side and the produced part may be equal to the difference of the squares on the other two sides.
65. Produce a given straight line so that the sum of the squares on the given straight line and on the part produced may be equal to twice the rectangle contained by the whole straight line thus produced and the part produced.
66. Produce a given straight line so that the sum of the squares on the whole line thus produced and on the part produced may be equal to three times the square on the given straight line.
67. Produce a given straight line so that the sum of the squares on the given straight line and on the whole straight line thus produced may be equal to twice the rectangle contained by the whole straight line thus produced and the part produced.

68. Produce a given straight line so that the rectangle contained by the whole straight line thus produced and the part produced may be equal to the square on the given straight line.
69. Divide a given straight line into two parts such that the rectangle contained by the whole line and one part may be one-fourth the square on the other part.
70. Divide a given straight line into two parts such that the square on one part may exceed the rectangle contained by the whole line and the other part by a given square.
71. Describe an isosceles obtuse-angled triangle such that the square on the longest side may be equal to three times the square on either of the equal sides.
72. Through a given point O draw three lines OA , OB , OC of given lengths, such that their extremities may be collinear, and that AB equals BC .
73. Any rectangle is equal to half the rectangle contained by the diagonals of squares described on its adjacent sides.
74. If, upon the greater segment AB of a line AC , divided in medial section, an equilateral triangle ABD be described, and CD joined, the square on CD equals twice the square on AB .
75. Prove that the sum of the squares on the straight lines, drawn from any point to the middle points of the sides of a triangle is less than the sum of the squares on the straight lines drawn from the same point to the angular points of the triangle by one-quarter the sum of the squares on the sides of the triangle.
76. Find the obtuse angle of a triangle when the square on the side opposite to the obtuse angle is greater than the sum of the squares on the sides containing it, by the rectangle of the sides.
77. Construct a rectangle equal to a given square when the sum of two adjacent sides of the rectangle is equal to a given quantity.
78. Construct a rectangle equal to a given square when the difference of two adjacent sides of the rectangle is equal to a given quantity.
79. If a rectangle is equal in area to a given square, its perimeter is least when it is congruent with the square.
80. The least square which can be inscribed in a given square is that which is half of the given square.
81. AB is divided at C so that the square on AC is double the square on CB ; the sum of AB and CB will be equal to the diagonal of the square on AB .

82. Show that, if two of the sides of a quadrilateral are parallel, the squares on the diagonals are together equal to the squares on the two sides which are not parallel and twice the rectangle contained by the parallel sides.
83. ABCD is a rectangle, and points E, F are taken in BC, CD respectively. Prove that twice the area of the triangle AEF, together with the rectangle BE.DF is equal to the rectangle AB.BC.
84. If perpendiculars be drawn from the angular points of a square to any line, the sum of the squares of the perpendiculars from one pair of opposite angles exceeds twice the rectangle of the perpendiculars from the other pair of opposite angles by the area of the square.
85. Prove that the sum of a square and a rhombus of equal perimeter is equal to one-quarter the square on the straight line which is the sum of the diagonals of the rhombus.
86. The diagonal AC of a rhombus ABCD is divided into any two parts at the point P: show that the rectangle AP.PC is equal to the difference between the squares on AB, PB.
87. In a quadrilateral ABCD, AC equals CD, AD equals BC, and the angles ACB, ADC are supplementary; show that the square on AB equals the sum of the squares on BC, CD, DA.
88. Three times the sum of the squares on the sides of any pentagon exceeds the sum of the squares on its diagonals, by four times the sum of the squares on the lines joining, in order, the middle points of the diagonals.
89. Show that three times the difference of the squares on the lines drawn from the vertex of a triangle to the points of trisection of the base is equal to the difference of the squares on the two sides of the triangle.
90. Show that the sum of the squares on the lines drawn from the vertex to the points of trisection of the base is less than the sum of the squares on the sides by four times the square on one-third of the base.
91. Show that, if the perimeter of a quadrilateral be given, the area will be greatest when it is a square.
92. A, B are two given points, and CD a given straight line not perpendicular to AB. Find a point P on the line CD, produced if necessary, such that the difference of the squares on PA and PB may be equal to twice the square on AB.

93. If the base AB of a triangle be divided in D , so that $m AD = n BD$; then $m AC^2 + n BC^2 = m AD^2 + n BD^2 + (m + n) CD^2$.
94. If D be taken in AB produced, and if $m AD = n BD$; then $m AC^2 - n BC^2 = m AD^2 - n BD^2 + (m - n) CD^2$.

LOCI.

1. Find the locus of a point which moves so that the sum of the squares on its distances from two fixed points may be constant.
2. Find the locus of a point such that the difference of the squares of its distances from two given points is constant.
3. Find the locus of a point, such that the sum of the squares on its distances from three given fixed points is constant.
4. A, B, C, D are fixed points, and P is a point such that the sum of the squares on PA, PB, PC, PD is constant; prove that P lies on a circle, the centre of which is at the point where the straight line joining the middle points of AB, CD cuts the straight line joining the middle points of AD, BC .
5. Of the $\triangle ABC$, the base BC is given, and the sum of the sides AB, AC ; find the locus of the point where the perpendicular from C to AC meets the bisector of the exterior vertical angle at A .
6. Of the $\triangle ABC$, the base BC is given, and the difference of the sides AB, AC ; find the locus of the point where the perpendicular from C to AC meets the bisector of the interior vertical angle at A .
7. Find the locus of a point, whose distance from one of two fixed points is double of its distance from the other.
8. Find the locus of a point P which moves in the plane of the triangle ABC so that twice the square on PA is equal to the sum of the squares on PB and PC .
9. A, B, C, D are fixed points, and P is a point such that the sum of the squares on PA, PB is equal to the sum of the squares on PC, PD ; find the locus of P .
10. If from a fixed point P two lines PA, PB , at right angles to each other, cut a given circle in the points A, B , the locus of the middle point of AB is a circle.
11. If a variable line, whose extremities rest on the circumferences of two given concentric circles, subtend a right angle at any fixed point, the locus of its middle point is a circle.

12. The square of the distance of a point P from a given point A is double the square of its distance from a given point B . Find the locus of P .
13. $ABCD$ is a rectangle ; P is a point such that the sum of PA and PC is equal to the sum of PB and PD : show that the locus of P consists of the two straight lines through the centre of the rectangle parallel to its sides.
14. Given the base of a triangle in magnitude and position, and the sum or difference of m times the square on one side and n times the square on the other side, find the locus of the vertex of the triangle.

EUCLID'S ELEMENTS

BOOK III.

DEFINITIONS

1. **Circle, circumference, centre.**—A circle is a plane figure contained by one line called the circumference, and is such that all straight lines drawn from a certain point within the figure to the circumference are equal to one another. This point is called the centre.

2. **Radius** —A straight line drawn from the centre to the circumference of a circle is called a radius.

3. **Diameter.**—A straight line drawn through the centre and terminated both ways by the circumference is called a diameter.

4. **Semi-circle.**—A figure contained by a diameter and the part of the circumference cut off by the diameter is called a semi-circle.

5. **Chord.**—A straight line which joins two points on the circumference of a circle is called a chord.

6. **Secant.**—A straight line which cuts the circumference of a circle in two points is called a secant.

7. **Arc.**—Any part of the circumference of a circle is called an arc.

8. **Tangent.**—A straight line which meets the circumference of a circle, but which, when produced, does not cut it, is called a tangent. The point at which the tangent meets the circle is called the point of contact.

9. **Touching of circles.**—Two circles which meet, but do not cut each other, are said to touch each other. The point at which they meet is called the point of contact.

10. **Segment.**—The figure contained by a chord of a circle and either of the arcs cut off by the chord is called a segment.

11. **Angle in a segment.**—The angle contained by two straight lines drawn from any point on the arc of a segment to the extremities of its chord, is called an angle in the segment.

12. **Similar segments.**—If the angles in two segments are equal, the segments are said to be similar.

13. **Sector.**—The figure contained by two radii of a circle and the arc included by them is called a sector.

14. **Angle of sector.**—The angle between the radii which bound a sector is called the angle of the sector.

From the definitions, the following simple theorems, which are assumed in the propositions, may readily be shown to be true :

- (a) A circle has only one centre.
- (b) A point is within a circle if its distance from the centre is less than the radius.
- (c) A point is without a circle if its distance from the centre is greater than the radius.
- (d) Two circles which have equal radii are equal.
- (e) Circles which are equal have equal radii.

PROPOSITION 1. PROBLEM.

To find the centre of a given circle.

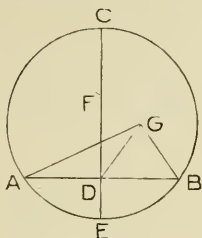
Let ABC be the given \odot .

It is required to find its centre.

Construction. Draw any chord AB , and bisect AB at D .From D draw $DC \perp AB$, I. 11.and produce CD to meet the \odot at E .Bisect CE at F . F shall be the centre of $\odot ABC$.For if F be not the centre, let G , a point which is not on the line CE , be the centre.Join GA , GD , GB .**Proof.** Then, in Δ s ADG , BDG ,

$$AD = BD,$$

$$DG = DG,$$

and base $AG =$ base BG , being radii of same \odot ,

$$\therefore \angle ADG = \text{adjacent } \angle BDG. \quad \text{I. 8.}$$

$$\therefore \angle ADG \text{ is a right angle.} \quad \text{Def.}$$

$$\text{But } \angle ADC \text{ is a right angle.} \quad \text{Constr.}$$

$$\therefore \angle ADC = \angle ADG,$$

the part equal to the whole, which is impossible.

$$\therefore G \text{ is not the centre.}$$

Similarly it may be shown that no point which is not on the line CE , can be the centre.

$$\therefore \text{the centre lies in } CE.$$

$$\therefore F, \text{ the middle point of } CE, \text{ is the centre.}$$

Cor.—A line which bisects any chord of a circle and is at right angles to it will pass through the centre.

PROPOSITION 2. THEOREM.

If any two points be taken on the circumference of a circle, the straight line which joins them shall fall within the circle.

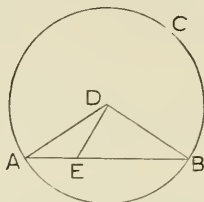

Let A and B be any two points on the \odot of $\odot ABC$, and let the chord AB be drawn.

It is required to prove that chord AB shall fall within the circle.

Construction. Find D, the centre of $\odot ABC$. III. 1.

In AB take any point E.

Join DA, DE, DB.

Proof. \because radius DA = radius DB,

\therefore in isosceles $\triangle DAB$, $\angle DAB = \angle DBA$. I. 5.

But ext. $\angle DEA$, of $\triangle DEB$, is greater than
int. opp. $\angle DBA$. I. 16.

$\therefore \angle DEA$ is greater than $\angle DAE$.

And \because in a \triangle , the greater \angle is subtended by the
greater side, I. 19.

\therefore DA is greater than DE.

\therefore E is within the \odot .

Similarly every other point in the chord may be shown to be within the \odot .

EXERCISES.

1. Prove that a straight line cannot cut the circumference of a circle in more than two points.
2. Find the locus of the centre of a circle, which passes through two given points.

PROPOSITION 3. THEOREM.

PART 1.

The straight line joining the centre of a circle to the middle point of a chord, which does not pass through the centre, is perpendicular to the chord.

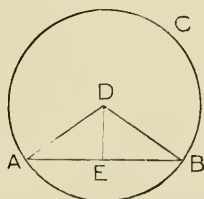

Let AB be any chord of $\odot ABC$ which does not pass through the centre D .

Let E be the middle point of the chord, and let DE be joined.

It is required to prove $DE \perp AB$.

Construction. Join DA and DB .

Proof. Then, in Δ s AED , BED ,

$$AE = BE,$$

$$ED = ED,$$

and base $AD =$ base BD , being radii of same \odot ,

$$\therefore \angle AED = \text{adjacent } \angle BED. \quad I. 8.$$

$$\therefore DE \perp AB.$$

EXERCISES.

1. Show that the straight line joining the middle points of two parallel chords of a circle passes through the centre.
2. If two circles intersect, show that the straight line joining their centres bisects their common chord at right angles.

PROPOSITION 3. THEOREM.

PART II.

The straight line drawn from the centre of a circle perpendicular to a chord bisects the chord.

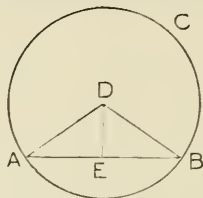

Let AB be any chord of $\odot ABC$, and from the centre D let DE be drawn $\perp AB$.

It is required to prove $AE = EB$.

Construction. Join DA, DB .

Proof. \because radius $DA =$ radius DB ,
 \therefore in isosceles $\triangle DAB$, $\angle DAB = \angle DBA$. *I. 5.*

Then, in $\triangle s$ AED, BED ,
 $\angle DAE = \angle DBE$,
 $\angle DEA = \angle DEB$, each being a rt. \angle ,
 and $DA = DB$,
 $\therefore AE = EB$. *I. 26.*

EXERCISES.

1. Through a given point O within a circle draw a chord which will be bisected at O .
2. A straight line cuts two concentric circles in the points A, B, C, D . Show that $AB = CD$.
3. If the straight line joining the middle points of two chords of a circle be perpendicular to one chord, show that it must be perpendicular to the other.

PROPOSITION 4. THEOREM.

If two chords of a circle, which do not both pass through the centre, cut each other, they do not bisect each other.

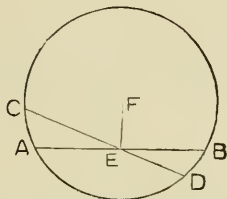

Let the two chords AB and CD, of \odot ADBC, cut each other at E, a point which is not the centre. It is required to prove that AB and CD do not bisect each other.

Construction. Find the centre F, and join FE. *III. 1.*

Proof. If possible, let $AE = EB$, and $CE = ED$.

Now, \because FE is drawn from the centre to the middle point of the chord AB,

$\therefore \angle FEB$ is a right \angle . *III. 3. I.*

And \because FE is drawn from the centre to the middle point of the chord CD,

$\therefore \angle FED$ is a right \angle . *III. 3. I.*

$\therefore \angle FEB = \angle FED$,

the less = the greater, which is impossible.

\therefore AB and CD do not bisect each other.

EXERCISES.

1. If two chords of a circle bisect each other, the chords are diameters.
2. Show that by joining the extremities of any two diameters of a circle, an inscribed rectangle is constructed.
3. Show that every parallelogram inscribed in a circle is a rectangle.

PROPOSITION 5. THEOREM.

If two circles cut each other they cannot have the same centre.

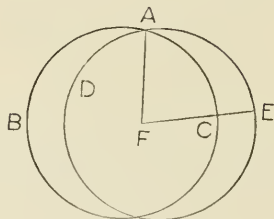

Let the two \odot s ABC, ADE cut each other at A.
It is required to prove that they cannot have the same centre.

Construction. If possible let them have the same centre F
Join FA, and draw any straight line from F, cutting the \odot es in C and E respectively.

Proof. Now, \because F is centre of \odot ABC,
 \therefore radius FA = radius FC.

And \because F is centre of \odot ADE,
 \therefore radius FA = radius FE.

\therefore FC = FE,

the less = the greater, which is impossible.

\therefore the \odot s cannot have the same centre.

PROPOSITION 6. THEOREM.

If two circles touch internally they cannot have the same centre.

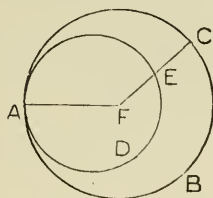

Let the \odot s ABC, ADE touch internally at the pt. A.

It is required to prove that they cannot have the same centre.

Construction. If possible let them have the same centre F.

Join FA, and draw any straight line from F, cutting the \odot es in E and C respectively.

Proof. Now, \because F is centre of \odot ABC,

\therefore radius FA = radius FC.

And \because F is centre of \odot ADE,

\therefore radius FA = radius FE.

\therefore FE = FC,

the less = the greater, which is impossible.

\therefore the \odot s cannot have the same centre.

EXERCISES.

1. Prove that two circles which have a common point cannot have the same centre.
2. Show that equal chords of a circle subtend equal angles at the centre.
3. Show that the greater of two chords of a circle subtends the greater angle at the centre.

PROPOSITION 7. THEOREM.

If from any point within a circle which is not the centre, straight lines be drawn to the circumference, the one which passes through the centre is the greatest; the remainder of that diameter is the least; of any two others the one which subtends the greater angle at the centre is the greater; and two, and only two, of the lines can be equal, one on each side of the diameter through the point.

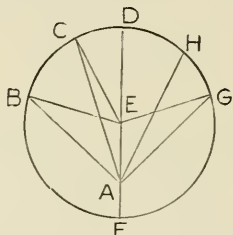

Let A be any point within the $\odot BCD$, and let the st. lines AB , AC , AD be drawn to meet the Oce , of which AD passes through the centre E , and let AF be the remainder of this diameter.

It is required to prove that, of st. lines drawn from A to the Oce ,

- (1) AD is the greatest,
- (2) AF is the least,
- (3) AC is greater than AB ,
- (4) two, and only two, equal st. lines can be drawn from A to the Oce , one on each side of diameter FD .

Construction. (1) Join EB , EC .

Proof. In $\triangle AEC$, the two sides AE and EC are together greater than AC ; I. 20.
and radius $EC = \text{radius } ED$,
 $\therefore AE$ and ED are together greater than AC ,
that is, AD is greater than AC .

Similarly it may be shown that AD is greater than any other st. line drawn from A to the Oce .

$\therefore AD$ is the greatest of all such lines.

Proof. (2) In $\triangle EAB$, the two sides EA and AB
are together greater than EB ; *I.* 20.
and radius EB = radius EF,

\therefore EA and AB are together greater than EF.

Take away the common part EA,

and \therefore AB is greater than AF.

Similarly it may be shown that any other st. line

drawn from A to the Océ is greater than AF.

\therefore AF is the least of all such lines.

Proof. (3) In $\triangle s$ AEC, AEB,
AE = AE,
EC = EB,

but included \angle AEC is greater than included \angle AEB,

\therefore AC is greater than AB. *I.* 24.

Construction. (4) At E in AE make \angle AEG = \angle AEB, *I.* 23.
and join AG.

Proof. In $\triangle s$ AEB, AEG,

AE = AE,

EB = EG,

and included \angle AEB = included \angle AEG,

\therefore AB = AG, *I.* 4.

Also, no other st. line can be drawn from

A to the Océ equal to AB.

For, if possible, let AH = AB.

Then \therefore AB = AG,

\therefore AH = AG.

But this is impossible, since AH subtends an angle at
the centre which is not equal to the angle subtended by AG,

\therefore two, and only two, equal st. lines can be
drawn from A to the Océ.

PROPOSITION 8. THEOREM.

If from any point without a circle, straight lines be drawn to the circumference, the one which passes through the centre is the greatest; the one which when produced passes through the centre is the least; of any two others the one which subtends the greater angle at the centre is the greater; and two, and only two, of the lines can be equal, one on each side of the diameter through the point.

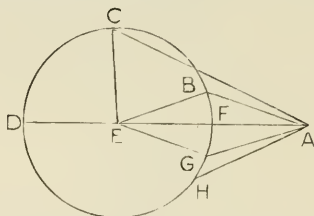

Let A be any point without the $\odot BCD$, and let the st. lines AB , AC , AD be drawn to meet the Oce , of which AD passes through the centre E , and let AF be the part of this line without the Oce .

It is required to prove that, of st. lines drawn from A to the Oce ,

- (1) AD is the greatest,
- (2) AF is the least,
- (3) AC is greater than AB ,
- (4) two, and only two, equal st. lines can be drawn from A to the Oce , one on each side of the diameter through A .

Construction. (1) Join EB and EC .

Proof. In $\triangle AEC$, the two sides AE and EC are together greater than AC ; *I. 20.*
and radius $EC =$ radius ED ,
 $\therefore AE$ and ED are together greater than AC ,
that is, AD is greater than AC .

Similarly it may be shown that AD is greater than any other st. line drawn from A to the Oce .

$\therefore AD$ is the greatest of all such lines.

Proof. (2) In $\triangle ABE$, the two sides AB and BE
are together greater than AE , *I. 20.*
that is, AB and BE are together greater than
 AF and FE together.

Take away the equals BE and FE ,
 $\therefore AB$ is greater than AF .

Similarly it may be shown that any other st. line
drawn from A to the *Oce* is greater than AF ,
 $\therefore AF$ is the least of all such lines.

Proof. (3) In $\triangle s$, AEC , AEB ,
 $AE = AE$,
 $EC = EB$,

but included $\angle AEC$ is greater than included $\angle AEB$,
 $\therefore AC$ is greater than AB . *I. 24.*

Construction. (4) At E in AE , make $\angle AEG = \angle AEB$, *I. 23.*
and join EG .

Proof. In $\triangle s$, AEB , AEG ,
 $AE = AE$,
 $EB = EG$,
and included $\angle AEB =$ included $\angle AEG$,
 $\therefore AB = AG$. *I. 4.*

Also, no other st. line can be drawn from
 A to the *Oce* equal to AB .

For, if possible, let $AH = AB$.

Then $\therefore AB = AG$,
 $\therefore AH = AG$.

But this is impossible, since AH subtends an angle at the
centre, which is not equal to the angle subtended by AG .
 \therefore two, and only two, equal st. lines can be
drawn from A to the *Oce*.

PROPOSITION 9. THEOREM.

If from a point within a circle, more than two equal straight lines can be drawn to the circumference, that point is the centre.

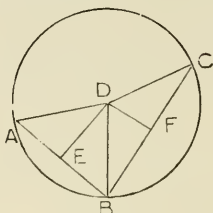

Let ABC be a \odot , and let three equal st. lines DA , DB , DC be drawn from the pt. D , within it, to the Oce.

It is required to prove that D is the centre of $\odot ABC$.

Construction. Join AB and BC , and bisect AB at E , and BC at F . Join DE and DF .

Proof. In Δ s AED , BED ,

$$AE = BE,$$

$$ED = ED,$$

and base $AD =$ base BD ,

Hyp.

$\therefore \angle AED =$ adjacent $\angle BED$; *I. 8.*

$\therefore DE \perp AB$.

And $\therefore DE$ also bisects AB ,

\therefore the centre of $\odot ABC$ must lie in DE . *III. 1 Cor.*

Similarly it may be shown that the centre lies in DF .

\therefore the centre must be at D , which is the only point common to DE and DF .

EXERCISE.

1. Give an indirect proof of Prop. 9, showing that no point other than D , can be the centre.

PROPOSITION 10. THEOREM.

One circle cannot cut another in more than two points.

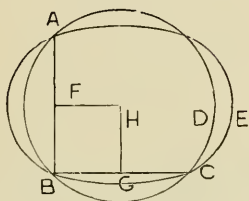

Let $ABCD$ and $ABCE$ be two \odot s.

It is required to prove that they cannot cut each other in more than two points.

Construction. If possible let the \odot s cut each other in the three points A , B , C .

Join AB and BC , and bisect AB at F and BC at G .
From F draw $FH \perp AB$, and from G draw $GH \perp BC$.

Proof. \because AB is a chord of each \odot ,
and AB is bisected at rt. \angle s by FH ,
 \therefore the centre of each \odot lies in FH . *III. 1 Cor.*

And \because BC is a chord of each \odot ,
and BC is bisected at rt. \angle s by GH ,
 \therefore the centre of each \odot lies in GH . *III. 1 Cor.*

\therefore H , the point of intersection of FH and GH ,
is the centre of both circles.

But this is impossible, since they cut each other. *III. 5.*

\therefore two \odot s cannot cut each other in more than two points.

PROPOSITION II. THEOREM.

If one circle touches another internally, the straight line joining their centres, being produced, passes through the point of contact.

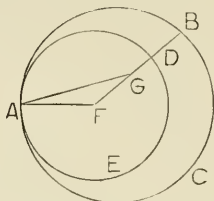

Let the \odot s ABC, ADE, touch internally at A, and let F be the centre of \odot ABC, and G the centre of \odot ADE.

Join FG.

It is required to prove that FG produced passes through A.

Construction. If FG do not pass through A, let it cut \odot ADE in D, and \odot ABC in B.

Join AF and AG.

Proof. \because G is centre of \odot ADE, \therefore GA = GD.

\therefore GA and GF together = FD.

But in \triangle AGF, GA and GF together are greater than FA. I. 20.

\therefore FD is greater than FA.

But \because F is centre of \odot ABC, \therefore FA = FB.

\therefore FD is greater than FB,

that is, the part greater than the whole, which is impossible.

\therefore FG must pass through A.

EXERCISE.

- Two circles touch internally at the point A. From A two chords APQ, ARS are drawn, the one meeting the circumferences in P and Q, and the other in R and S. If the radius of the one circle is double that of the other, show that the straight line QS is double the straight line PR.

PROPOSITION 12. THEOREM.

If one circle touches another externally, the straight line joining their centres, passes through the point of contact.

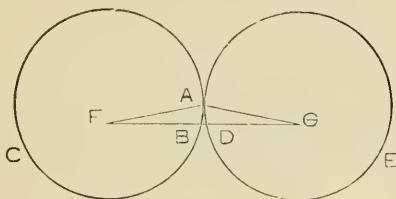

Let the \odot s ABC, ADE, touch externally at A, and let F be the centre of \odot ABC, and G the centre of \odot ADE.

Join FG.

It is required to prove that FG passes through A.

Construction. If FG do not pass through A, let it cut \odot ABC at B, and \odot ADE at D.

Join AF and AG.

Proof. \because F is centre of \odot ABC,

\therefore FA = FB.

And \because G is centre of \odot ADE,

\therefore AG = DG.

\therefore FA and AG together = FB and DG together,

\therefore FA and AG together are less than FG,

But, in \triangle FAG, the two sides FA and AG together are greater than FG,

\therefore FA and AG together are both greater than and less than FG, which is impossible.

\therefore FG passes through A.

EXERCISES.

1. Find the locus of the centre of a circle of given radius, which touches a given circle.
2. Find the locus of the centre of a circle which touches a given circle at a given point.

PROPOSITION 13. THEOREM.

One circle cannot touch another at more points than one.

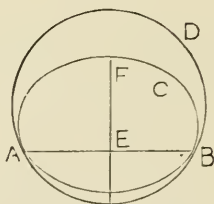

Let ABC and ABD be two \odot s which touch at a pt. A

It is required to prove that they cannot touch at any other point.

Construction. If possible let them touch at another pt. B.

Join AB, bisect AB at E, and draw $EF \perp AB$.

Proof. \because AB is a chord of each \odot ,

\therefore the centre of each \odot lies in EF; *III. 1 Cor.*

\therefore EF passes through each point of contact. *III. 11, 12.*

But EF does not pass through each pt. of contact,

\therefore A and B are not in the line EF.

\therefore the \odot s cannot touch at more points than one.

PROPOSITION 14. THEOREM.

PART I.

Equal chords in a circle are equidistant from the centre.

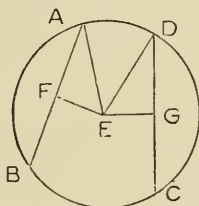

Let the chords AB and CD in the \odot ABCD be equal.

It is required to prove that they are equidistant from the centre.

Construction. Find E the centre of the \odot , and from E draw $EF \perp AB$, and $EG \perp CD$.

Join EA, ED.

Proof. \because EF is drawn from the centre of \odot ABC, and \perp the chord AB,
 $\therefore AF = FB$, III. 3.
 and $\therefore AF$ is half of AB.

Similarly it may be shown that DG is half of CD.

But $AB = CD$,

$\therefore AF = DG$.

And $\because EA = ED$,

\therefore sq. on EA = sq. on ED.

But, $\because \angle EFA$ is a rt. \angle ,

\therefore sq. on EA = sum of squares on AF and EF. I. 47.

And, $\because \angle EGD$ is a rt. \angle ,

\therefore sq. on ED = sum of squares on DG and EG.

\therefore sum of squares on AF and EF = sum of squares on DG and EG.

But $\because AF = DG$, \therefore sq. on AF = sq. on DG.

\therefore remainder sq. on EF = remainder sq. on EG,

and $\therefore EF = EG$,

\therefore AB and CD are equidistant from the centre.

PROPOSITION 14. THEOREM.

PART II.

Chords in a circle which are equidistant from the centre are equal.

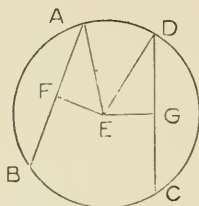

Let the chords AB and CD in the \odot ABCD be equidistant from the centre E, that is, let the \perp s EF and EG be equal.

It is required to prove $AB = CD$.

Construction. Join EA and ED.

Proof. \because EF is drawn from the centre of the \odot ABC, and \perp the chord AB,
 $\therefore AF = FB$, *III. 1 Cor.*
 and $\therefore AB$ is double of AF.

Similarly it may be shown that CD is double of DG.

And $\because EA = ED$,

\therefore sq. on EA = sq. on ED.

But $\because \angle EFA$ is a rt. \angle ,

\therefore sq. on EA = sum of squares on EF and AF. *I. 47.*

And $\because \angle EGD$ is a rt. \angle ,

\therefore sq. on ED = sum of squares on EG and DG,

\therefore sum of squares on AF and EF = sum of squares on DG and EG.

But $\because EF = EG$, \therefore sq. on EF = sq. on EG,

\therefore remainder sq. on AF = remainder sq. on DG,

and $\therefore AF = DG$.

But AB is double of AF, and CD double of DG,

$\therefore AB = CD$.

EXERCISES.

1. Find the locus of the middle points of all chords of a circle, equal to a given chord.
2. Prove that if two equal chords intersect, the segments of the one are respectively equal to the segments of the other.

PROPOSITION 15. THEOREM.

PART I.

The diameter is the greatest chord of a circle.

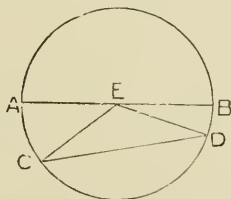

Let AB be a diameter, and CD any chord of the $\odot ABC$, which is not a diameter.

It is required to prove AB greater than CD .

Construction. Find the centre E , and join EC and ED .

Proof. $\because EA = EC$, and $EB = ED$, all being radii,
 $\therefore EA$ and EB together = EC and ED together.

But, in $\triangle ECD$, EC and ED are together greater than CD . I. 20.

$\therefore EA$ and EB are together greater than CD ,
 that is, AB is greater than CD ,
 and $\therefore AB$ is the greatest chord of the \odot .

PROPOSITION 15. THEOREM.

PART II.

The chord of a circle which is nearer the centre is greater than one more remote.

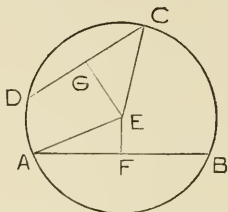

Let AB and CD be two chords of the \odot ABC, and let EF and EG be the \perp s on these chords from the centre E, and let EF be less than EG.

It is required to prove AB greater than CD.

Construction. Join EA and EC.

Proof. \because EF is drawn from the centre \perp chord AB,
 \therefore AF = FB, III. 3.

And \therefore AB is double of AF.

Similarly, it may be shown that CD is double of CG.

Again \because EA = EC,

\therefore sq. on EA = sq. on EC.

But \because \angle EFA is a rt. \angle ,

\therefore sq. on EA = sum of squares on EF and AF. I. 47.

And \because \angle EGC is a rt. \angle ,

\therefore sq. on EC = sum of squares on EG and CG.

\therefore sum of squares on EF and AF = sum of squares
 on EG and CG.

But \because EF is less than EG,

\therefore sq. on EF is less than sq. on EG.

\therefore sq. on AF is greater than sq. on CG.

\therefore AF is greater than CG.

\therefore AB is greater than CD.

PROPOSITION 15. THEOREM.

PART III.

The greater chord of a circle is nearer the centre than the less.

(Same Figure as in Part II.)

Let AB and CD be two chords of the \odot ABC, of which AB is the greater. Let EF and EG be the \perp s on these chords from the centre E.

It is required to prove EF less than EG.

Construction. Join EA and EC.

Proof. \therefore EF is drawn from the centre \perp chord AB,
 \therefore AF = FB, III. 3.

And \therefore AB is double of AF.

Similarly, it may be shown that CD is double of CG.

And \therefore AB is greater than CD,

\therefore AF is greater than CG.

And \therefore EA = EC,

\therefore sq. on EA = sq. on EC.

But \therefore \angle EFA is a rt. \angle ,

\therefore sq. on EA = sum of squares on EF and AF. I. 47.

And \therefore \angle EGC is a rt. \angle ,

\therefore sq. on EC = sum of squares on EG and CG.

\therefore sum of squares on EF and AF = sum of squares on EG and CG.

But \therefore AF is greater than CG,

\therefore sq. on AF is greater than sq. on CG.

\therefore sq. on EF is less than sq. on EG.

\therefore EF is less than EG.

EXERCISES.

1. Through a given point within a circle draw the shortest chord.
2. Through a given point within or without a given circle draw a chord equal to a given chord.
3. Two chords of a circle which cut one another, and make equal angles with the diameter through their point of intersection, are equal.
4. A chord of a circle, of length sixteen inches, is distant six inches from the centre. Find the length of the chord which is distant eight inches.

PROPOSITION 16. THEOREM.

The straight line drawn through a point on a circle at right angles to the radius to the point, touches the circle, and every other straight line through the point cuts the circle.

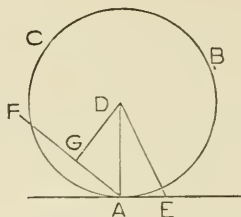

Let ABC be a \odot , of which D is the centre.

Through any pt. A on the \odot let the st. line AE be drawn
 \perp radius DA .

It is required to prove that

- (1) AE touches the \odot .
- (2) Every other st. line through A cuts the \odot .

Construction. (1) Take any pt. E , in AE , and join DE .

Proof. \therefore in $\triangle DAE$, $\angle DAE$ is a rt. \angle ,
 $\therefore \angle DEA$ is less than a rt. \angle . I. 17.
 $\therefore \angle DAE$ is greater than $\angle DEA$,
 and \therefore side DE is greater than side DA . I. 19.
 $\therefore E$ is without the \odot .

Similarly, it may be shown that every point
 in AE , except A , is without the \odot .

$\therefore AE$ touches the \odot . Def.

Construction. (2) Through A draw any other st. line AGF .

It is required to prove that AF cuts the \odot .

From D draw $DG \perp AF$.

Proof. \therefore in $\triangle DGA$, $\angle DGA$ is a rt. \angle ,
 $\therefore \angle DAG$ is less than a rt. \angle . I. 17.
 $\therefore \angle DAG$ is less than $\angle DGA$,
 and \therefore side DG is less than side DA . I. 19.
 $\therefore G$ is within the \odot .
 $\therefore AF$ must cut the \odot .

EXERCISES.

1. Prove that a straight line cannot touch a circle in more than one point.
2. All chords of a circle which are equal touch a concentric circle.
3. Show how to draw a tangent to a circle which shall be parallel to a given straight line.
4. Describe a circle which will pass through a given point and also touch a given straight line at a given point.
5. If two circles touch, they have a common tangent at the point of contact.
6. If two circles touch a straight line at the same point they touch each other at that point.

PROPOSITION 17. THEOREM.

From a given point to draw a tangent to a given circle.

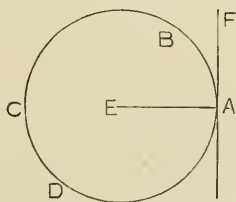

Let A be the given point and BCD the given \odot .

It is required to draw through A a tangent to \odot BCD.

(1) Let the pt. A be on the \odot .

Construction. Find the centre E,

and join EA. Draw $AF \perp EA$.

AF will be a tangent to \odot BCD.

Proof. \because the st. line AF is drawn through

A, a point on the \odot , and \odot radius EA,

\therefore AF touches \odot BCD.

III. 16.

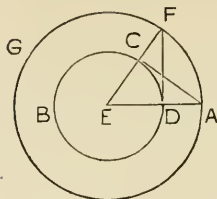

(2) Let the pt. A be outside the \odot .

Construction. Find the centre E,
and join EA, cutting \odot BCD in D.

With centre E and radius EA, describe \odot AFG.

From D draw $DF \perp EA$. Join EF,
and let EF cut \odot BCD in C. Join AC.

AC will be a tangent to \odot BCD.

Proof. In Δ s, AEC, FED,

$$AE = FE,$$

$$EC = ED,$$

and included $\angle AEC =$ included $\angle FED$.

$$\therefore \angle ACE = \angle FDE. \quad I. 4.$$

But $\angle FDE$ is a rt. \angle .

$\therefore \angle ACE$ is a rt. \angle .

And \therefore the st. line AC is drawn through

C, a point on the \odot , and \perp radius EC,

\therefore AC touches \odot BCD.

EXERCISES.

1. Prove that the two tangents which can be drawn from an external point to a circle are equal.
2. The quadrilateral which is formed by four tangents to a circle is such that the sum of one pair of sides is equal to the sum of the other pair.
3. In a given straight line find a point such that the tangent drawn from it to a given circle may be equal to a given straight line.
4. Find the locus of a point from which the tangents drawn to a given circle are equal to a given straight line.

PROPOSITION 18. THEOREM.

If a straight line touch a circle the radius drawn to the point of contact is at right angles to the line.

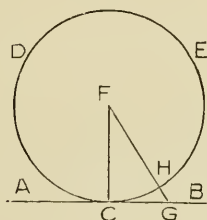

Let the st. line AB touch the \odot CED at the pt. C.

Let F be the centre of the \odot and join FC.

It is required to prove $FC \perp AB$.

Construction. If FC be not \perp AB, draw $FG \perp AB$, cutting the \odot in H.

Proof. \therefore in $\triangle FCG$, $\angle FGC$ is a rt. \angle ,

$\therefore \angle FCG$ is less than a rt. \angle , I. 17.

and \therefore side FC is greater than side FG. I. 19.

But $FC = FH$, being radii of \odot CED,

$\therefore FH$ is greater than FG ,

the part greater than the whole, which is impossible.

$\therefore FC$ must be \perp AB.

PROPOSITION 19. THEOREM.

If a straight line touch a circle, the straight line drawn at right angles to it from the point of contact, passes through the centre.

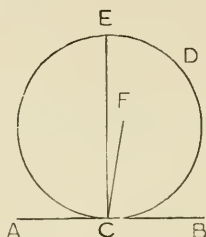

Let the st. line AB touch the \odot CDE at the pt. C.

From C draw $CE \perp AB$.

It is required to prove that CE passes through the centre.

Construction. Find F the centre of the \odot , *III. 1.*
and if CE do not pass through F, join FC.

Proof. \because AB touches the \odot at C, and

FC is drawn from the centre,

$\therefore \angle FCB$ is a rt. \angle . *III. 18.*

But $\angle ECB$ is a rt. \angle .

$\therefore \angle FCB = \angle ECB$,

the less equal to the greater, which is impossible.

\therefore CE must pass through the centre.

EXERCISES.

1. If two tangents to a circle are parallel, their points of contact are the extremities of a diameter.
2. Show that if the sides of a quadrilateral touch a circle the sum of the angles which one pair of opposite sides subtends at the centre is equal to two right angles.
3. Find the locus of the centres of circles touching two given intersecting straight lines.
4. Describe a circle of given radius, which will touch each of two given straight lines.

PROPOSITION 20. THEOREM.

The angle at the centre of a circle is double of the angle at the circumference which stands on the same arc.

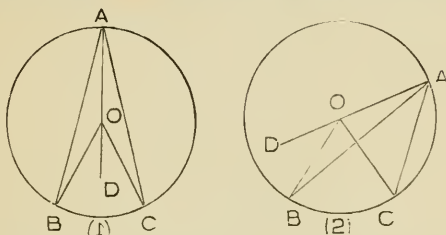

In the $\odot ABC$ let $\angle BOC$ at the centre O and $\angle BAC$ at the Oce , stand on the same arc BC .

It is required to prove that $\angle BOC$ is double of $\angle BAC$.

Construction. Join AO and produce AO to D .

Proof. $\because OA = OB, \therefore \angle OBA = \angle OAB.$ *I. 5.*

But ext. $\angle BOD =$ sum of int. opp. $\angle s$ $OBA, OAB.$ *I. 32.*

$\therefore \angle BOD$ is double of $\angle OAB$.

Similarly, it may be shown that

$\angle COD$ is double of $\angle OAC$.

If O falls within $\angle BAC$, as in fig. (1),

\therefore sum of $\angle s$ BOD, COD is double sum of $\angle s$ OAB, OAC ,

that is, $\angle BOC$ is double of $\angle BAC$.

And, if O falls without $\angle BAC$, as in fig. (2),

\therefore difference of $\angle s$ BOD, COD is double difference

of $\angle s$ OAB, OAC ,

that is, $\angle BOC$ is double of $\angle BAC$.

NOTE.—If the arc on which the angle stands is greater than a semi-circle, the angle at the centre is greater than two right angles. Euclid never referred directly to such an angle, although Prop. 33 of Book VI. necessarily implies that such angles are to be considered. These angles are commonly called **reflex** angles. An angle less than two rt. angles and the corresponding reflex angle are called **conjugate** angles, and their sum is evidently four right angles. In the following, and later propositions no distinction will be made in the treatment of angles, whether less or greater than two right angles

PROPOSITION 21. THEOREM.

Angles at the circumference of a circle which stand on the same arc are equal.

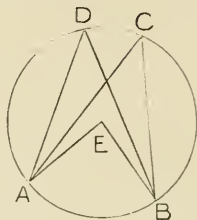

In \odot ABCD, let the \angle s ACB, ADB, at the Oce, stand on the same arc AB.

It is required to prove \angle ACB = \angle ADB.

Construction. Find the centre E, and join EA and EB.

Proof. \therefore \angle AEB at the centre, and \angle ACB at the Oce, stand on the same arc AB,

\therefore \angle AEB is double of \angle ACB. III. 20.

Similarly, it may be shown that \angle AEB is double of \angle ADB.

\therefore \angle ACB = \angle ADB.

EXERCISES.

1. The locus of a point on one side of a given straight line at which the line subtends an angle, equal to a given angle, is an arc of a circle.
2. If two chords of a circle, AB and CD, intersect at E, show that the triangles CAE and BDE are equiangular.

PROPOSITION 22. THEOREM.

The sum of two opposite angles of a quadrilateral inscribed in a circle is equal to two right angles.

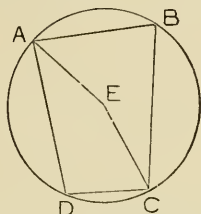

Let the quadrilateral $ABCD$ be inscribed in the $\odot ABC$.

It is required to prove that

the sum of the opposite \angle s ABC , ADC is two rt. \angle s.

Construction. Find the centre E , and join EA and EC .

Proof. $\therefore \angle AEC$ at the centre, and $\angle ABC$ at the Oce,
stand on the same arc ADC ,

$\therefore \angle AEC$ is double of $\angle ABC$. *III. 20.*

And \therefore reflex $\angle AEC$ at the centre, and $\angle ADC$ at the Oce,
stand on the same arc ABC ,

\therefore reflex $\angle AEC$ is double of $\angle ADC$.

\therefore sum of $\angle AEC$ and reflex $\angle AEC$ is double sum
of $\angle ABC$ and $\angle ADC$.

But the sum of $\angle AEC$ and reflex $\angle AEC$
is four right angles.

\therefore the sum of \angle s ABC , ADC is two rt. \angle s.

EXERCISES.

1. If a parallelogram is inscribed in a circle, it must be a rect angle.
2. If one side of a quadrilateral inscribed in a circle be produced, the exterior angle is equal to the interior opposite angle.
3. If a triangle is inscribed in a circle, the sum of the angles in the segments exterior to the triangle are together equal to four right angles.

4. If a quadrilateral is inscribed in a circle, the sum of the angles in the segments exterior to the quadrilateral are together equal to six right angles.
5. If a quadrilateral have two of its opposite angles together equal to two right angles, a circle can be described about it.
6. The feet of the perpendiculars drawn from any point on a circle to the sides of an inscribed triangle lie on a straight line.

PROPOSITION 23. THEOREM.

On the same straight line, and on the same side of it, there cannot be two similar segments of circles not coinciding with each other.

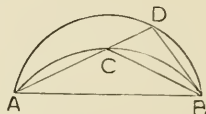

Let ACB and ADB be two similar segments of \odot s, on the same st. line AB, and on the same side of it.

It is required to prove that they must coincide.

Construction. For, if they do not coincide, from A draw the st. line ACD cutting them respectively in C and D.

Join BC and BD.

Proof. $\therefore \angle$ s ACB, ADB are \angle s in similar segments,
 $\therefore \angle$ ACB = \angle ADB. *Def.*

But in \triangle BCD,

ext. \angle ACB is greater than int. opp. \angle ADB. *I. 16.*

$\therefore \angle$ ACB is both equal to and greater than \angle ADB,
 which is impossible,

\therefore the segments must coincide.

PROPOSITION 24. THEOREM.

Similar segments of circles on equal straight lines are equal.

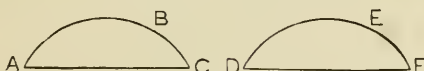

Let ABC and DEF be two similar segments of \odot s on equal st. lines AC and DF .

It is required to prove segment $ABC =$ segment DEF .

Proof. If segment ABC be applied to segment DEF ,

so that A is on D and AC falls on DF ,

then, $\because AC = DF$, $\therefore C$ will coincide with F ;

and if segment ABC falls on the same side of DF as
the similar segment DEF ,

\therefore the segment ABC coincides with segment DEF . III. 23.

\therefore segment $ABC =$ segment DEF .

PROPOSITION 25. PROBLEM.

An arc of a circle being given, to complete the circle.

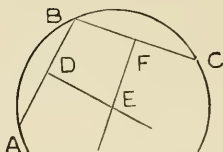

Let ABC be an arc of a \odot .

It is required to complete the \odot .

Construction. Let A, B, C be any three points in the arc.

Join AB, BC .

Bisect AB at D and draw $DE \perp AB$.

Bisect BC at F and draw $FE \perp BC$,

meeting DE at E . Join EA .

Then the \odot described with E as centre and

EA as radius will be the complete \odot .

Proof. \because DE bisects the chord AB at rt. \angle s,

\therefore DE passes through the centre. *III 1, Cor.*

And \because FE bisects the chord BC at rt. \angle s,

\therefore FE passes through the centre.

\therefore E , the pt. common to DE and FE is the centre.

\therefore the \odot described with E as centre, and EA as radius is the complete \odot .

EXERCISES.

1. Find the centre of a circle which passes through three given points.
2. Find the centre of a circle which touches a given circle at a given point and passes through another given point.

PROPOSITION 26. THEOREM.

In equal circles, the arcs which subtend equal angles, whether they are at the centres or at the circumferences, are equal.

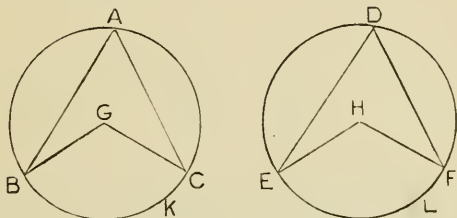

Let ABC , DEF be equal \odot s, and let \angle s BGC , EHF at their centres, and, \therefore \angle s BAC , EDF at their \odot es, be equal.

It is required to prove arc $BKC =$ arc ELF .

Proof. For, if $\odot ABC$ be applied to $\odot DEF$,
so that G coincides with H ,

then, \therefore the \odot s are equal, their \odot es will coincide,
and if GB falls on HE , $\therefore B$ will coincide with E .

And $\therefore \angle BGC = \angle EHF$, $\therefore GC$ will fall on HF ,
and $\therefore C$ will coincide with F .

Then $\therefore B$ coincides with E and C with F ,

\therefore arc BKC coincides with arc ELF ,

\therefore arc $BKC =$ arc ELF .

EXERCISE.

In the same circle, the arcs which subtend equal angles, whether they are at the centre or at the circumference, are equal.

PROPOSITION 27. THEOREM.

In equal circles, the angles which are subtended by equal arcs, whether they are at the centres or at the circumferences, are equal.

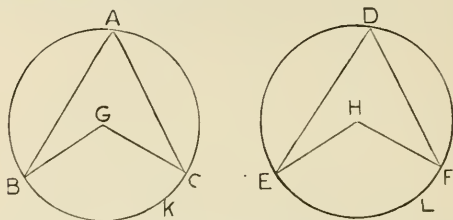

Let ABC , DEF be equal \odot s, and let \angle s BGC , EHF at their centres, and \angle s BAC , EDF at their \odot es, be subtended by equal arcs BKC , ELF .

It is required to prove $\angle BGC = \angle EHF$,
and $\angle BAC = \angle EDF$.

Proof. For, if $\odot ABC$ be applied to $\odot DEF$,
so that G coincides with H ,

then, \because the \odot s are equal, their \odot es will coincide,
and if GB falls on HE , $\therefore B$ will coincide with E ;
and \because arc $BKC =$ arc ELF , $\therefore C$ will coincide with F .

Hence, GC will coincide with HF .

Then $\because GB$ coincides with HE , and GC with HF ,

$\therefore \angle BGC$ coincides with $\angle EHF$,
and $\therefore \angle BGC = \angle EHF$.

Again, $\because \angle BAC =$ half of $\angle BGC$, III. 20.

and $\angle EDF =$ half of $\angle EHF$,

$\therefore \angle BAC = \angle EDF$.

EXERCISE.

In the same circle, the angles which are subtended by equal arcs, whether they are at the centre or at the circumference, are equal.

PROPOSITION 28. THEOREM.

In equal circles, the arcs which are subtended by equal chords are equal, the greater to the greater, and the less to the less.

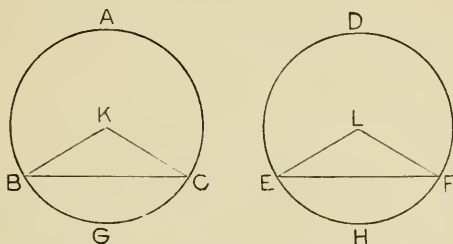

Let ABC , DEF be equal \odot s, and BC , EF equal chords, subtending the greater arcs BAC , EDF , and the less arcs BGC , EHF .

It is required to prove arc $BAC =$ arc EDF ,
and arc $BGC =$ arc EHF .

Construction. Find the centres K , L ,
and join KB , KC , LE , LF .

Proof. Then in Δ s BKG , ELF ,
 $\therefore KB = LE$, and $KC = LF$, and $BC = EF$,
 $\therefore \angle BKC = \angle ELF$. I. 8.

Hence if $\odot ABC$ be applied to the equal $\odot DEF$,
so that K coincides with L , and KB falls on LE ,

$\therefore B$ will coincide with E ;

and $\therefore \angle BKC = \angle ELF$, $\therefore KC$ will fall on LF ;

and $\therefore C$ will coincide with F .

Then $\therefore B$ coincides with E , and C with F ,

\therefore arc BAC coincides with arc EDF ,

and arc BGC with arc EHF ,

\therefore arc $BAC =$ arc EDF , and arc $BGC =$ arc EHF .

EXERCISE.

In the same circle, the arcs which are subtended by equal chords are equal, the greater to the greater, and the less to the less.

PROPOSITION 29. THEOREM.

In equal circles, the chords which subtend equal arcs are equal.

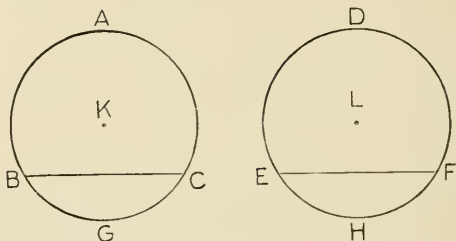

Let ABC, DEF be equal \odot s, and let BC, EF be chords subtending the equal arcs BGC, EHF.

It is required to prove chord BC = chord EF.

Construction. Take the centres K, L.

Proof. Then, if \odot ABC be applied to \odot DEF, so that K coincides with L,

then \therefore the \odot s are equal, their \odot ces will coincide, and if B coincides with E, and arc BGC falls on arc EHF, then \therefore arc BGC = arc EHF, \therefore C will coincide with F.

And \therefore B coincides with E and C with F,

\therefore chord BC coincides with chord EF,

and \therefore chord BC = chord EF.

EXERCISE.

In the same circle, the chords which subtend equal arcs are equal.

PROPOSITION 30. PROBLEM.

To bisect a given arc.

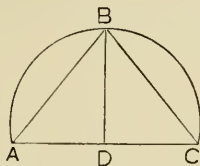

Let ABC be the given arc.

It is required to bisect it.

Construction. Join AC, and bisect AC at D.

Draw $DB \perp AC$, meeting the arc at B.

The arc ABC will be bisected at B.

Join AB and BC.

Proof. In Δ s ADB, CDB,

$$AD = CD,$$

$$DB = DB,$$

and included $\angle ADB =$ included $\angle CDB$,

$$\therefore AB = CB.$$

I. 4.

Now \therefore BD, if produced, passes through the centre,

III. I. Cor.

\therefore each of the arcs AB, CB is less than a semi-circle.

But arcs cut off by equal chords are equal,
the greater to the greater and the less to the less. *III. 28.*

$$\therefore \text{arc } AB = \text{arc } CB,$$

\therefore the arc ABC is bisected at B.

EXERCISES.

1. Divide a given arc into four equal parts.
2. Divide the arc of a semi-circle into six equal parts.
3. If two circles cut each other, the straight line joining their centres, being produced, bisects the four arcs of the circles.
4. If a tangent of a circle is parallel to a chord, the arc cut off by the chord is bisected at the point of contact.

PROPOSITION 31. THEOREM.

The angle in a semi-circle is a right angle; the angle in a segment greater than a semi-circle is less than a right angle; and the angle in a segment less than a semi-circle is greater than a right angle.

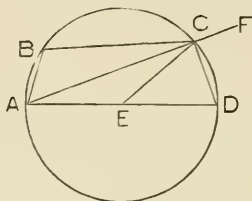

Let ABCD be a \odot , of which the segment ACD is a semi-circle, the segment ADC greater than a semi-circle, and the segment ABC less than a semi-circle.

It is required to prove

- (1) $\angle ACD$, which is in semi-circle ACD, a rt. \angle ,
- (2) $\angle ADC$, which is in segment ADC, less than a rt. \angle ,
- (3) $\angle ABC$, which is in segment ABC, greater than a rt. \angle .

Construction. Find the centre E, and join EC.

Produce AC to F.

Proof. (1) \because radius EA = radius EC,
 \therefore in isosceles $\triangle EAC$, $\angle ECA = \angle EAC$. I. 5.

And \because radius ED = radius EC,
 \therefore in isosceles $\triangle EDC$, $\angle ECD = \angle EDC$.

\therefore whole $\angle ACD =$ sum of \angle s EAC, EDC.

But ext. $\angle FCD$ of $\triangle ACD =$ sum of int.

opp. \angle s EAC, EDC. I. 32.

$\therefore \angle ACD =$ adj. $\angle FCD$.

$\therefore \angle ACD$ is a rt. \angle . Def.

(2) In $\triangle ACD$, the sum of \angle s ACD, ADC
 is less than two rt. \angle s. I. 17.

But $\angle ACD$ is a rt. \angle .

$\therefore \angle ADC$ is less than a rt. \angle .

- (3) \therefore ABCD is a quadrilateral inscribed in a \odot ,
 \therefore the sum of the two opp. \angle s ABC, ADC
 $=$ two rt. \angle s. III. 22.
 But \angle ADC is less than a rt. \angle .
 \therefore \angle ABC is greater than a rt. \angle .

EXERCISES.

1. The circles described on any two sides of a triangle as diameters intersect on the third side.
2. Through one of the points of intersection of two circles diameters are drawn. Show that the straight line joining the other ends of the diameters passes through the other point of contact.
3. If right-angled triangles are described on the same hypotenuse, the angular points opposite the hypotenuse all lie on a circle described on the hypotenuse as diameter.

PROPOSITION 32. THEOREM.

If a chord be drawn from the point of contact of a tangent to a circle, each of the angles which this chord makes with the tangent is equal to the angle in the alternate segment.

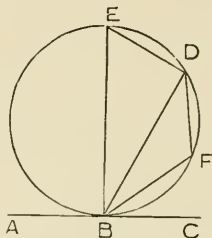

Let the st. line ABC touch the \odot BDE, at the point B, and let the chord BD be drawn, dividing the \odot into the segments BED, BFD.

It is required to prove

$\angle ABD = \angle$ in segment BFD,
and $\angle CBD = \angle$ in segment BED.

Construction. From B draw $BE \perp AC$.

In arc BFD take any pt. F.

Join BF, FD and DE.

Proof. \because BE is drawn \perp tangent AC, from its point of contact,

\therefore BE passes through the centre. III. 19.

\therefore segment BDE is a semicircle,

and $\therefore \angle BDE$ is a right \angle . III. 31.

And \because the three \angle s of a Δ together = two rt. \angle s, I. 32.

\therefore the sum of \angle s BED, EBD = a rt. \angle .

But the sum of \angle s CBD, EBD = a rt. \angle .

\therefore sum of \angle s CBD, EBD = sum of \angle s BED, EBD.

$\therefore \angle CBD = \angle BED$, which is in segment BED.

Again \therefore BFDE is a quadrilateral inscribed in a \odot ,
 \therefore the sum of opp. \angle s BFD, BED = two rt. \angle s. III. 22.
 And the sum of adjacent \angle s ABD, CBD = two rt. \angle s. I. 13.
 \therefore sum of \angle s ABD, CBD = sum of \angle s BFD, BED.
 But \angle CBD = \angle BED,
 \therefore \angle ABD = \angle BFD, which is in segment BFD.

EXERCISES.

1. Enunciate and prove the converse of III. 32.
2. If two circles touch, show that any straight line drawn through the point of contact cuts off similar segments.
3. Show that if an equilateral triangle be inscribed in a circle, the tangents at its angular points form another equilateral triangle.
4. Show that if an equiangular polygon be inscribed in a circle, the tangents at its angular points form another equiangular polygon.
5. If two circles touch, and two straight lines be drawn through the point of contact, the chords joining their extremities are parallel.

PROPOSITION 33. PROBLEM.

On a given straight line to describe a segment of a circle which shall contain an angle equal to a given angle.

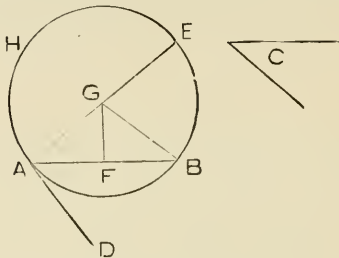

Let AB be the given st. line, and $\angle C$ the given \angle .

It is required to describe on AB a segment of a circle which shall contain an angle $= \angle C$.

Construction. At the pt. A in AB ,
make $\angle BAD = \angle C$. I. 23.

From A draw $AE \perp AD$.

Bisect AB at F , and from F draw $FG \perp AB$,
meeting AE in G .

With centre G and radius GA describe $\odot AEH$.

This \odot shall pass through B , and
the segment AEB shall contain an angle $= \angle C$.

Join GB .

Proof. In Δs AFG , BFG ,
 $AF = BF$,
 $FG = FG$,

and included angle $\angle AFG =$ included $\angle BFG$,
each being a rt. \angle ,

\therefore base $GA =$ base GB . I. 4.

$\therefore \odot AEH$ passes through B .

Again, $\because AD \perp AE$, which passes through the centre G ,
 $\therefore AD$ touches $\odot AEH$ at A . III. 16.

But AB is a chord drawn from pt. of contact.

$\therefore \angle BAD = \angle$ in alternate segment AEB . III. 32.

But $\angle BAD = \angle C$,

$\therefore \angle$ in segment $AEB = \angle C$.

Digitized by Microsoft®

PROPOSITION 34. PROBLEM.

From a given circle to cut off a segment which shall contain an angle equal to a given angle.

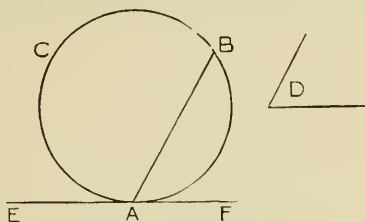

Let ABC be the given \odot and $\angle D$ the given \angle .
It is required to cut off from $\odot ABC$ a segment which shall contain an angle $= \angle D$.

Construction. At A , any pt. on the \odot , draw the tangent EAF . *III.* 17.

At the pt. A in AF , make $\angle FAB = \angle D$. *I.* 23.

The segment ACB , on the side of AB , remote from F , is the required segment.

Proof. $\because AB$ is a chord of $\odot ABC$,
and EAF is a tangent at A ,
 $\therefore \angle FAB =$ angle in alternate segment ACB . *III.* 32.

But $\angle FAB = \angle D$.

\therefore angle in segment $ACB = \angle D$.

EXERCISES.

1. Construct a triangle having given the base, the vertical angle, and the length of the perpendicular to the base.
2. Construct a triangle having given the base, the vertical angle, and the length of the straight line drawn from the vertex to the middle point of the base.
3. Having given the base and the vertical angle of a triangle, construct the triangle of maximum area.
4. Through a given point draw a straight line which shall cut off from a given circle a segment containing an angle equal to a given angle.

PROPOSITION 35. THEOREM.

If two chords of a circle cut each other, the rectangle contained by the segments of the one shall be equal to the rectangle contained by the segments of the other.

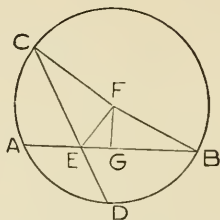

Let the two chords AB and CD , of the $\odot ACBD$, cut each other at the pt. E .

It is required to prove $\text{rect. } AE.EB = \text{rect. } CE.ED$.

Construction. If E be the centre of the \odot , it is evident that $\text{rect. } AE.ED = \text{rect. } CE.ED$, for each $\text{rect.} =$ the sq. on the radius.

If E be not the centre, find the centre F ,
and draw $FG \perp AB$, and join BF, CF, EF .

Proof. $\because FG$ is drawn from the centre F , \perp chord AB ,
 $\therefore AG = GB$. III. 3.

$\because AB$ is divided equally at G , and unequally at E ,
 $\therefore \text{rect. } AE.EB + \text{sq. on } EG = \text{sq. on } GB$. II. 5.

To each of these equals, add $\text{sq. on } FG$.

$\therefore \text{rect. } AE.EB + \text{sq. on } EG + \text{sq. on } FG$
 $= \text{sq. on } GB + \text{sq. on } FG$.

But $\because \angle s$ EGF, BGF are $\text{rt. } \angle s$,

$\therefore \text{sq. on } EG + \text{sq. on } FG = \text{sq. on } EF$,

and $\text{sq. on } GB + \text{sq. on } FG = \text{sq. on } FB$.

$\therefore \text{rect. } AE.EB + \text{sq. on } EF = \text{sq. on } FB$.

Similarly, it may be shown that

$$\begin{aligned} \text{rect. CE.ED} + \text{sq. on EF} &= \text{sq. on FC, that is,} \\ &= \text{sq. on FB.} \end{aligned}$$

$$\therefore \text{rect. AE.EB} + \text{sq. on EF} = \text{rect. CE.ED} + \text{sq. on EF.}$$

$$\therefore \text{rect. AE.EB} = \text{rect. CE.ED.}$$

EXERCISES.

1. Enunciate and prove the converse of III. 35.
2. If through any point in the common chord of two intersecting circles there be drawn any two other chords, their four extremities all lie on one circle.
3. Show how to produce a given straight line so that the rectangle contained by the line and the part produced may be equal to a given rectangle.

PROPOSITION 36. THEOREM.

If from a point without a circle there be drawn two straight lines, one of which cuts the circle and the other touches it, the rectangle contained by the whole line which cuts the circle, and the part of it without the circle, is equal to the square on the tangent.

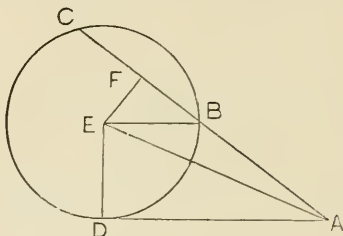

From the pt. A without the \odot BCD, let the two st. lines AD and ABC be drawn, of which AD touches the \odot at D, and ABC cuts it at B and C.

It is required to prove

$$\text{rect. CA.AB} = \text{sq. on AD.}$$

Construction. Find the centre E, and draw $EF \perp BC$.

Join AE, BE and DE.

Proof. \because EF is drawn from the centre E, \perp chord BC,
 $\therefore CF = FB.$ III. 3.

And \because CB is bisected at F, and produced to A,

$$\therefore \text{rect. CA.AB} + \text{sq. on FB} = \text{sq. on FA.} \quad \text{II. 6.}$$

To each of these equals, add sq. on EF.

$$\begin{aligned} \therefore \text{rect. CA.AB} + \text{sq. on FB} + \text{sq. on EF} \\ = \text{sq. on FA} + \text{sq. on EF.} \end{aligned}$$

But \because \angle EFB is a rt. \angle ,

$$\therefore \text{sq. on FB} + \text{sq. on EF} = \text{sq. on EB,} \quad \text{I. 47.}$$

$$\text{and sq. on FA} + \text{sq. on EF} = \text{sq. on EA.}$$

$$\therefore \text{rect. CA.AB} + \text{sq. on EB} = \text{sq. on EA.}$$

But \because AD is a tangent, and ED is drawn from the
centre to the pt. of contact,

$\therefore \angle$ EDA is a rt. \angle ; III. 18.

\therefore sq. on EA = sq. on AD + sq. on ED.

And \therefore rect. CA.AB + sq. on EB = sq. on AD + sq. on ED.

But \because EB = ED, being radii,

\therefore sq. on EB = sq. on ED,

\therefore rect. CA.AB = sq. on AD.

EXERCISES.

1. If two circles cut each other, the tangents drawn to the two circles from any point in the common chord produced are equal.
2. Produce a given straight line so that the rectangle contained by the given line and the whole line produced may be equal to a given rectangle.
3. If three circles touch each other, show that the tangents at the points of contact meet in a point.

PROPOSITION 37. THEOREM.

If from a point without a circle there be drawn two straight lines, one of which cuts the circle and the other meets it, and if the rectangle contained by the whole line which cuts the circle and the part of it without the circle be equal to the square on the line which meets the circle, then the line which meets the circle is a tangent.

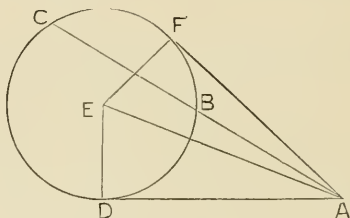

From the pt. A without the \odot BCD, let the two st. lines AD and ABC be drawn, of which AD meets the circle at D, and ABC cuts it at B and C; and let rect. CA.AB = sq. on AD.

It is required to prove that AD is a tangent to the \odot BCD.

Construction. Find the centre E.

Draw AF, touching the circle at F, *III.* 17.
and join EF, EA and ED.

Proof. \because AF touches the \odot at F, and
ABC cuts it at B and C,
 \therefore rect. CA.AB = sq. on AF. *III.* 36.
But rect. CA.AB = sq. on AD. *Hyp.*
 \therefore sq. on AF = sq. on AD,
 \therefore AF = AD.

Also \because EF is drawn from the centre E
to F, the point of contact of AF,
 \therefore \angle EFA is a rt. \angle . *III.* 18.

And in Δ s EDA, EFA,
AD = AF,
DE = FE, being radii,
and AE = AE,
 \therefore \angle ADE = \angle AFE. *I.* 8.

But \angle AFE is a rt. \angle ,
 \therefore \angle ADE is a rt. \angle .

And \because AD is drawn \perp radius DE,
AD is a tangent. *III.* 16.

EXERCISES.

PROBLEMS.

1. Describe a circle which shall have its centre on a given straight line and pass through two given points.
2. Describe a circle which shall pass through two given points and have a given radius.
3. Describe a circle with a given radius to touch a given circle at a given point.
4. Describe a circle to pass through a given point and touch a given circle at a given point.
5. Describe a circle with a given radius to touch two given circles.
6. Describe a circle which shall pass through a given point and touch a given straight line at a given point.
7. Describe a circle with a given radius which shall have its centre in a given straight line and touch another given straight line.
8. Describe a circle of given radius to pass through a given point and touch a given straight line.
9. Describe a circle with a given radius which shall touch a given circle and a given straight line.
10. Describe a circle with a given radius to touch two given straight lines.
11. Describe a circle which shall touch a given circle, have its centre on a given straight line, and pass through a given point in the given straight line.
12. Describe a circle which shall touch a given circle and a given straight line at a given point.
13. Describe a circle which shall touch a given circle at a given point, and also a given straight line.
14. Given the radii and the common chord of two intersecting circles, describe the circles.
15. Describe a circle of given radius, with its centre on one given circle and touching another given circle.
16. Describe a circle touching two given circles and having its centre on a given diameter of one of these circles.
17. Describe a circle which shall touch the hypotenuse of a right-angled triangle, have its centre in one of the sides, and pass through the right angle.
18. Describe a circle which shall touch a given circle, and two tangents to the given circle.

19. Describe a circle which shall have its centre in a given straight line, touch another given straight line, and pass through a fixed point in the first given line.
20. Describe a circle which shall have its centre in a given straight line and cut off equal chords of a given length from two given straight lines.
21. Describe a circle which shall touch a given straight line and pass through two given points.
22. Describe a circle which shall touch a given circle and pass through two given points.
23. Describe a circle passing through a given point and touching two given straight lines.
24. Describe a circle passing through a given point and touching a given straight line and a given circle.
25. Describe a circle passing through a given point and touching two given circles.
26. Describe a circle to touch two given straight lines and a given circle.
27. Describe a circle to touch a given straight line and two given circles.
28. Describe a circle to touch three given circles.
29. Describe a circle with a given centre which shall bisect the circumference of a given circle.
30. Describe a circle which shall pass through two given points and bisect the circumference of a given circle.
31. Describe a circle which shall pass through a given point and bisect the circumferences of two given circles.
32. Describe a circle so as to bisect the circumferences of each of three given circles.
33. Describe a circle to touch a given straight line at a given point so that the tangents drawn to it from the extremities of the given straight line may be parallel.
34. Describe a circle with a given radius touching a given straight line such that the tangents drawn to it from the extremities of the given straight line may be parallel.
35. Describe a circle which shall touch two given circles, one of them at a given point.
36. Describe a circle passing through two given points and cutting orthogonally a given circle.

37. Describe a circle passing through a given point and cutting orthogonally two given circles.
38. Describe a circle cutting orthogonally three given circles.
39. Describe a circle which shall cut off three chords, each equal to a given straight line, from the sides of a triangle.
40. Describe three circles touching one another in pairs and having their centres at three fixed points.
41. Describe a circle to touch two given concentric circles and to pass through a given point, which lies between the two given circumferences.
42. Draw a circle to cut three given circles so that two of the chords of intersection may be parallel respectively to given straight lines, and that the third may pass through a given point.
43. Describe a circle bisecting the circumferences of two given circles and cutting a third given circle so that the common chord may be of given length.
44. Describe a circle so that each of its chords of intersection with three given circles shall pass through a fixed point.
45. Construct a triangle, having given the centres of the escribed circles.
46. Construct a triangle, having given the base, the vertical angle, and a straight line in which the vertex is to lie.
47. Construct a triangle, having given the base, the vertical angle, and another side.
48. Construct a triangle, having given the base, the vertical angle, and the altitude.
49. Construct a triangle, having given the base, the median to the base, and the vertical angle.
50. Construct a triangle, having given the base, the point at which the perpendicular from the vertex meets the base and the vertical angle.
51. Construct a triangle, having given the base, the vertical angle, and the point at which the bisector of the vertical angle meets the base.
52. Construct a triangle, having given the base, the vertical angle, and one of the medians on the sides.
53. Construct a triangle, having given the base, the vertical angle, and the sum of the other two sides.
54. Construct a triangle, having given the base, the vertical angle, and the difference of the other two sides.

55. Construct a triangle, having given an angle and the radii of the inscribed and circumscribed circles.
56. Construct a triangle, having given the base, the altitude, and the radius of the circumscribed circle.
57. Given the base of a triangle, one of the angles at the base, and the radius of the inscribed circle, construct the triangle.
58. Given the vertical angle of a triangle, one of the sides containing it, and the length of the perpendicular from the vertex to the base, construct the triangle.
59. Construct a triangle, having given the base, the vertical angle, and the radius of the inscribed circle.
60. Construct a triangle, having given the base, the vertical angle, and the point of contact of the inscribed circle with the base.
61. Construct a triangle, having given the angles, and the radius of the inscribed circle.
62. Construct a triangle, having given the sum of the sides, the difference of the segments of the base made by the perpendicular from the vertex, and the difference of the base angles.
63. Construct a triangle, having given the base, the vertical angle, and the orthocentre.
64. Describe a triangle equal in all respects to a given triangle and having its sides passing through three given points.
65. Describe a triangle, equiangular to a given triangle, whose sides shall pass through three given points, and whose area shall be a maximum.
66. Construct the least triangle equiangular to a given triangle, and whose vertices shall lie on three given lines.
67. Construct the greatest triangle equiangular to a given triangle whose sides shall touch three given circles.
68. Given the base, the vertical angle, and the rectangle of the sides, construct the triangle.
69. Construct an equilateral triangle having its vertex at a given point, and the extremities of its base on a given circle.
70. Construct an equilateral triangle having its vertex at a given point, and the extremities of its base in two given circles.

MISCELLANEOUS.

1. Show that the straight lines drawn at right angles to the sides of a quadrilateral inscribed in a circle from their middle points intersect at a fixed point.
2. If two circles cut each other, any two parallel straight lines drawn from the points of section to cut the circles are equal.
3. If a circle be described on the radius of another circle as diameter, prove that any chord of the greater circle drawn from the point of contact is bisected by the smaller circle.
4. A and B are the centres of two circles CDF, CEG, which touch each other at C, DE passes through C ; show that AD is parallel to BE.
5. If in any two given circles which touch each other, there be drawn two parallel diameters, an extremity of each diameter, and the point of contact shall lie in the same straight line.
6. Through a given point within a given circle draw the shortest chord.
7. Two segments of circles are described on the same chord and on the same side of it ; the extremities of the common chord are joined to any point on the arc of the exterior segment ; show that the arc intercepted on the inner segment is constant.
8. Two segments of circles are on the base AB, and P is any point in the circumference of one of the segments; the straight lines APD, BPC are drawn meeting the circumference of the other segment in D and C ; AC and BD are drawn intersecting at Q ; show that the angle AQB is constant.
9. X and Y are any two points taken on two arcs described on the same straight line PQ, and on the same side of it ; show that, if the bisectors of the angles XPY and XQY meet in O, then PQ subtends a constant angle at O.
10. From A and B two of the angles of a triangle ABC, straight lines are drawn so as to meet the opposite sides at P and Q in given equal angles ; show that the straight line joining P and Q will be of the same length in all triangles on the same base AB, and having vertical angles equal to C.
11. Draw parallel to a given straight line, a straight line to touch a given circle.
12. Draw perpendicular to a given straight line, a straight line to touch a given circle.

13. Through a given point within a given circle draw two equal chords at right angles to each other.
14. If a quadrilateral be described about a circle, the angles subtended at the centre of the circle by any two opposite sides of the figure are together equal to two right angles.
15. Two tangents are drawn to a circle at the opposite extremities of a diameter, and cut off from a third tangent a portion AB ; if C be the centre of the circle show that ACB is a right angle.
16. Two radii of a circle at right angles to each other when produced are cut by a straight line which touches the circle; show that the tangents drawn from the points of section are parallel to each other.
17. A quadrilateral is bounded by the diameter of a circle, the tangents at its extremities, and a third tangent; show that its area is equal to half that of the rectangle contained by the diameter and the side opposite to it.
18. If from the extremities of any diameter of a circle perpendiculars are dropped on any chord, their feet are equidistant from the centre.
19. APB is an arc of a circle less than a semi-circle; tangents are drawn at A and B and at any intermediate point P ; show that the sum of the sides of the triangle formed by the three tangents is invariable for all positions of P .
20. AB is the diameter and C the centre of a semi-circle; show that O the centre of any circle inscribed in the semi-circle is equidistant from C and from the tangent to the semi-circle parallel to AB .
21. Two circles intersect in the points A, B ; C, D are the points of contact of a common tangent; show that CD subtends supplementary angles at A and B .
22. Two equal circles intersect at right angles; show that the square on their common chord is equal to twice the square on the radius.
23. AB, AC are two chords of a circle, and BD is drawn parallel to the tangent at A to meet AC in D ; show that the circle BCD will touch AB .
24. AB and CD are two parallel diameters of two circles, and AC cuts the circles again in the points P, Q respectively. Show that the tangents at P and Q are parallel.

25. Two circles intersect, and through one of the points of intersection a line is drawn to meet the circumferences again; show that this line subtends a constant angle at the other point of section.
26. APB is a fixed chord passing through P , a point of intersection of two circles, AQP , BRP ; and QPR is any other chord of the circles passing through P ; show that AQ and BR when produced meet at a constant angle.
27. Two circles intersect, and through one of the points of section a pair of straight lines are drawn to meet the circumferences in four points; show that if the pairs of points on each circle are joined, the joining lines intersect at a constant angle.
28. AB is a common chord of two circles; through C any point of one circumference straight lines CAD , CBE are drawn, terminated by the other circumference; prove that the arc DE is constant.
29. If from any point without a circle tangents be drawn to it, the angle contained by them is double the angle contained by the straight line joining the points of contact, and the diameter drawn through one of them.
30. C is the centre of a given circle, CA a radius, B a point on a radius at right angles to CA ; join AB and produce it to meet the circle again at D and let the tangent at D meet CB produced at E ; show that BDE is an isosceles triangle.
31. Let the diameter BA of a circle be produced to P , so that AP equals the radius; through A draw the tangent AED , and from P draw PEC touching the circle at C , and meeting the former tangent at E ; join BC and produce it to meet AED at D ; then will the triangle DEC be equilateral.
32. Two tangents AB , AC are drawn to a circle; D is any point on the circumference outside of the triangle ABC ; show that the sum of the angles ABD and ACD is constant.
33. If X , Y , Z be any three points on the three sides of a triangle ABC , the three circles about the triangles YAZ , ZBX , XCX pass through a common point.
34. AB is the diameter of a circle; AC , AD are two chords meeting the tangent at B in the points E , F respectively; prove that the points C , D , F , E are concyclic.
35. The straight lines bisecting any angle of a quadrilateral inscribed in a circle and the opposite exterior angle, meet in the circumference of the circle.

36. AOB and COD are diameters of a circle at right angles to each other; E is a point in the arc AC and EFG is a chord meeting COD at F, and drawn in such a direction that EF is equal to the radius, show that the arc BG is equal to three times the arc AE.
37. The straight lines which bisect the vertical angles of all triangles on the same base and on the same side of it, and having equal vertical angles, all intersect at the same point.
38. If ABC be a circle, AB a diameter, PD a fixed line perpendicular to AB; then if ACP be any line cutting the circle in C and the line PD in P, the rectangle AP.AC is constant.
39. The hypotenuse AB of a right-angled triangle ABC is bisected at D, and EDF is drawn at right angles to AB; DE and DF are cut off each equal to DA; CE and CF are joined; show that the last two straight lines will bisect the angle C and its supplement respectively.
40. If from the centre of a circle a perpendicular be let fall on any line GD, and from D, the foot of the perpendicular, and from any other point G in GD two tangents DE, GF be drawn to the circle, then $GF^2 = GD^2 + DE^2$.
41. The greatest rectangle which can be inscribed in a circle is a square.
42. If equilateral triangles be described on the three sides of any triangle, the circles described about these equilateral triangles intersect in a common point.
43. The lines joining the vertices of the original triangle to the opposite vertices of the equilateral triangles are concurrent.
44. The centres of the circles are the angular points of another equilateral triangle.
45. From any point P in the diagonal BD of a parallelogram ABCD, straight lines PE, PF, PG, PH are drawn perpendicular to the sides AB, BC, CD, DA: show that EF is parallel to GH.
46. On the side AB of any triangle ABC as diameter a circle is described; EF is a diameter parallel to BC: show that the straight lines EB and FB bisect the interior and exterior angles at B.
47. Through the ends of a fixed chord of a given circle are drawn two other chords parallel to each other; prove that the straight line joining the other ends of these chords will touch a fixed circle.

48. If two circles ABC , ABD intersect at A and B , and AC , AD be two diameters, show that the straight line CD will pass through B .
49. If the centres of two circles which touch each other externally be fixed, the common tangent of those circles will touch another circle of which the straight line joining the fixed centres is the diameter.
50. A straight line and two circles are given : find the point in the straight line from which the tangents drawn to the circles are of equal length.
51. P , Q , R , S are the middle points of the arcs of the circle $ABCD$, cut off by the sides of the cyclic quadrilateral $ABCD$. Show that PR is perpendicular to QS .
52. If from the angles at the base of any triangle perpendiculars are drawn to the opposite sides, produced if necessary, the straight line joining the points of intersection will be bisected by a perpendicular drawn to it from the centre of the base.
53. AD is a diameter of a circle ; B and C are points on the circumference on the same side of AD ; a perpendicular from D on BC produced through C , meets it at E ; show that the square on AD is greater than the sum of the squares on AB , BC , CD , by twice the rectangle $BC.CE$.
54. In the circumference of a given circle determine a point so situated that if chords be drawn to it from the extremities of a given chord of the circle their difference shall be equal to a given straight line less than the given chord.
55. The lines drawn from the centre of the circle described about a triangle to the angular points are perpendicular to the sides of the triangle formed by joining the feet of the perpendiculars from the angles to the opposite sides of the original triangle.
56. If squares be described on the sides and hypotenuse of a right-angled triangle, the straight line joining the intersection of the diagonals of the latter square with the right angle is perpendicular to the straight line joining the intersections of the diagonals of the two former.
57. Two equal circles touch each other externally, and through the point of contact chords are drawn, one to each circle, at right angles to each other ; show that the straight line joining the other extremities of these chords is equal and parallel to the straight line joining the centres of the circles.

58. If AB be the diameter of a semi-circle, and AC , BD , two chords intersecting in O , the circle about the triangle OCD intersects the semi-circle orthogonally.
59. D , E are the feet of the perpendiculars from A , B on the opposite sides of the triangle ABC ; if DP , EQ are drawn perpendicular to AC and BC respectively, show that PQ is parallel to AB .
60. AB is any chord, and AD is a tangent to a circle at A . DPQ is any straight line parallel to AB , meeting the circumference at P and Q . Show that the triangle PAD is equiangular to the triangle QAB .
61. If two circles touch each other internally, and parallel diameters are drawn, the lines joining corresponding ends of these diameters will pass through the point of contact.
62. If from any point in the circumference of a circle a chord and tangent be drawn, the perpendiculars dropped on them from the middle point of the subtended arc are equal to each other.
63. Two diameters AOB , COD of a circle are at right angles to each other; P is a point in the circumference; the tangent at P meets COD produced at Q , and AP , BP meet the same line at R , S respectively; show that RQ is equal to SQ .
64. If on the sides of a triangle and remote from it, segments of circles are described, such that the sum of the angles in these segments is equal to two right angles, these circles will intersect in a point.
65. C is the centre of a circle, and CA is a line less than the radius, find the point in the circumference at which CA subtends the greatest angle.
66. Two diameters in a circle are at right angles; from their extremities four parallel straight lines are drawn; show that they divide the circumference into four equal parts.
67. $AOCB$ is a diameter of a circle whose centre is O ; DCE is any chord through C on a constant arc DE ; if AD and BE meet in P , prove that the angle DPE is constant.
68. A secant OAB and a tangent OP are drawn to a circle from an external point O , and the bisector of the angle APB meets AB in C ; prove that OC is equal to OP .
69. AB is the diameter of a semi-circle, D , E are any two points on the circumference; if the chords joining A , B to D , E meet in F , G , show that FG is perpendicular to AB .

70. B is a point in the circumference of a circle whose centre is C ; PA is a tangent at a point P meeting CB produced in A ; PM is drawn perpendicular to CB ; prove that BP bisects the angle MPA.
71. Find a point inside a triangle at which the three sides shall subtend equal angles. Is this always possible ?
72. Circles are described on the sides containing the right angle of a right-angled triangle as diameters ; show that the square on their common tangent is equal the area of the triangle.
73. It is required to find a point on a tangent which touches a circle at the extremity of a given diameter, such that when a straight line is drawn from this point to the other extremity of the diameter, the rectangle contained by the part of it without the circle and the part within may be equal to a given square not greater than that on the diameter.
74. Through any fixed point in a chord of a circle other chords are drawn ; show that the straight lines from the middle point of the first chord to the middle points of the others will meet them all at the same angle.
75. If two chords of a circle meet at right angles within or without a circle, the squares on their segments are together equal to the square on the diameter.
76. If an equilateral triangle be inscribed in a circle and two adjacent arcs be bisected, prove that the line joining the points of bisection is trisected by the sides of the triangle.
77. If the perpendiculars of a triangle be produced to meet the circumference of the circumscribed circle, the parts of the perpendiculars intercepted between their point of intersection and the circumference are bisected by the sides of the triangle.
78. If two circles touch each other internally, and if any circle be described touching both the circles, show that the perimeter of the triangle formed by joining the three centres is constant.
79. If three circles touch one another two and two, show that the tangents drawn to them at the three points of contact are equal, and meet in a point.
80. Two circles whose centres are A and B intersect at C ; through C two chords DCE and FCG are drawn equally inclined to AB and terminated by the circles ; show that DE and FG are equal.

81. Through either of the points of intersection of two circles draw the greatest possible straight line terminated both ways by the two circumferences.
82. From one of the points of intersection of two circles straight lines are drawn equally inclined to the common chord of the circles; prove that the portions of these lines, intercepted between the other points in which they meet the circumferences of the circles, are equal.
83. Through a given point draw a circle whose circumference shall be at equal distances from three given points.
84. Describe three circles of given radii to touch each other externally.
85. Describe three circles of given radii such that two shall touch each other externally and the third internally.
86. A circle is described on the radius of another circle as diameter, and two chords of the larger circle are drawn, one through the centre of the less at right angles to the common diameter, and the other at right angles to the first through the point where it cuts the less circle. Show that these chords have the segments of the one equal to the segments of the other, each to each.
87. A and B are two points within a fixed circle, such that the rectangle contained by the segments of any chord through A is equal to the rectangle contained by the segments of any chord through B; show that A and B are equidistant from the centre.
88. In the diameter of a circle produced find a point so that the tangent drawn from it to the circumference shall be of given length.
89. Find a point without a given circle such that the angle between the tangents drawn from that point to the given circle may be equal to a given angle.
90. If AC, BD be two equal chords of a circle, one of the pairs of lines AD, BC and AC, BD are equal, and the other pair parallel.
91. If a quadrilateral be described about a circle; show that two of its sides are together equal to the other two.
92. Show that every parallelogram described about a circle is a rhombus.
93. AL, BM, CN are parallel chords of a circle; prove that the triangles ABC, LMN are equal.

94. A straight line is drawn touching two circles ; show that the chords are parallel which join the points of contact and the points where the straight line through the centres meets the circumferences.
95. The four extremities of any two parallel straight lines, which are both bisected at right angles by the same straight line, lie on a circle.
96. A quadrilateral, having two of its sides parallel, is inscribed in a circle ; show that the remaining sides and the diagonals will all touch each of two circles whose centres are on the given circle.
97. The tangent at A to one circle is parallel to the chord BC of another circle ; AB, AC cut the first circle in D, E and the other circle in F, G ; show that DE is parallel to FG.
98. If two circles touch each other internally, any chord of the greater circle which touches the less shall be divided at the point of its contact into segments which subtend equal angles at the point of contact of the two circles.
99. If two circles touch internally and a straight line is drawn to cut them, the segments of it intercepted between the circumferences subtend equal angles at the point of contact.
100. A, B are two fixed points on a circle and C, D the extremities of a chord of constant length ; show that the point of intersection of AC and BD is on one or other of two fixed circles.
101. If two circles can be described so that each touches the other and three sides of a quadrilateral, then the difference between the sums of the opposite sides is double the common tangent drawn across the quadrilateral.
102. If a quadrilateral having two of its sides parallel, be described about a circle, a straight line drawn through the centre of the circle, parallel to the parallel sides, and terminated by the other sides, shall be equal to a fourth part of the perimeter of the quadrilateral.
103. Show that if a circle passes through the centre of another circle, the tangents to the latter circle at the points of intersection of the two circles will meet on the former circle.
104. Of all straight lines which can be drawn from two given points to meet in the convex circumference of a given circle, the sum of the two is least which make equal angles with the tangent at the point of concurrence.

105. Two circles touch each other externally at the point P , and a straight line touches the circles in the points A , B respectively; show that the circle whose diameter is AB passes through P and touches the line joining the centres of the circles.
106. If through the middle point A of a given arc BAC any chord AD is drawn, cutting BC in E , the rectangle $AD \cdot AE$ is constant.
107. P , Q are any two points in the circumferences of two segments described on the same straight line AB , and on the same side of it; the angles PAQ , PBQ are bisected by the straight lines AR , BR meeting at R : show that the angle ARB is constant.
108. Any point P is taken on a given arc of a circle described on the line AB , and perpendiculars AG , BH are dropped on BP , AP respectively; show that GH is of constant length and touches a fixed circle whose centre is the middle point of AB .
109. $ABCD$ is a cyclic quadrilateral; a circle is described passing through the points A , B , another through B , C , a third through C , D , and a fourth through D , A ; these circles intersect successively in four other points, E , F , G , H , forming another cyclic quadrilateral.
110. A quadrilateral can have one circle inscribed in it and another circumscribed about it; show that the straight lines joining the opposite points of contact of the inscribed circle are perpendicular to each other.
111. ABP , ABC are two circles, O being the centre of the former, intersecting in A and B ; P is any point in ABP , and AC , BD are chords of the other circle passing through P . Prove that OP and CD are at right angles.
112. Two circles cut in P . Through P a chord is drawn in each circle to touch the other; if these chords are equal, prove that the circles are equal.
113. AB is a diameter of a given circle; P is a point on the circumference, and PQ is perpendicular to AB . If circles be described on AQ and BQ as diameters, meeting AP and BP in X and Y respectively, show that XY is a common tangent to the two circles.
114. A circle A passes through the centre of a circle B ; prove that their common tangents will touch A in points lying on a tangent to B .

115. A is a given point ; it is required to draw from A two straight lines which shall contain a given angle and intercept on a given straight line a part of given length.
116. Find a point in the circumference of a given circle, such that the lines joining it to two fixed points in the circumference may make a given intercept on a given chord of the circle.
117. The distance between the feet of the perpendiculars from any point in the circumference of a circle on two fixed radii is equal to the perpendicular from the extremity of either of these radii on the other.
118. If O be the orthocentre of the triangle ABC, the circles described about the triangles ABC, AOB, BOC, COA are equal.
119. The circle through B, C and the orthocentre of the triangle ABC meets the median AX produced in E ; show that AE is twice AX.
120. The two angles at the base of a triangle are bisected by two straight lines on which perpendiculars are drawn from the vertex ; show that the straight line which passes through the feet of these perpendiculars will be parallel to the base and will bisect the sides.
121. AB is a fixed chord of a circle, AC is a movable chord of the same circle ; a parallelogram is described of which AB and AC are adjacent sides ; determine the greatest possible length of the diagonal drawn through A.
122. With the extremities of the diameter of a semi-circle as centres, any two other semi-circles are drawn touching each other externally, and a straight line is drawn to touch them both, prove that this straight line will also touch the original semi-circle.
123. If a circle be circumscribed about a triangle, and from the ends of the diameter perpendicular to the base, perpendiculars be drawn to the other two sides, these perpendiculars will intercept on the sides segments equal to half the sum or half the difference of the sides.
124. Two circles have external contact at O ; through O draw a line of given length, terminated by the circumferences of the circles.
125. From C two tangents CD, CE are drawn to a semi-circle whose diameter is AB ; the chords AE, BD intersect at F ; prove that CF produced is perpendicular to AB.
126. On the same supposition, prove that if the chords AD, BE intersect at G, GC produced is perpendicular to AB.

127. If the common tangents to two intersecting circles meet the common chord produced in P , Q , show that the sum of the squares on a common tangent and on the common chord is equal to the square on PQ .
128. Through two points A , B on the same diameter of a circle and equi-distant from its centre two parallel straight lines AP , BQ are drawn towards the same parts meeting the circle in P and Q ; show that PQ is perpendicular to AP and BQ .
129. A and B are the centres of two circles CDF , CEG , which touch each other at C ; a circle BHL concentric with the circle CDF passes through B . If AH passes through D , and DE through C , show that BH is equal and parallel to DE .
130. O is the centre of a circle, P is any point in its circumference, PN a perpendicular on a fixed diameter; show that the straight line which bisects the angle OPN always passes through one or the other of two fixed points.
131. To draw a common tangent to two given circles.
132. Draw a straight line cutting two given circles so that the chords intercepted within the circles shall have given lengths.
133. Three circles touch each other externally at the points A , B , C ; from A , the straight lines AB , AC are produced to cut the circle BC at D and E ; show that DE is a diameter of BC , and is parallel to the straight line joining the centres of the other circles.
134. If from any point in the circumference of a circle three lines are drawn to the angles of an inscribed equilateral triangle, one of these lines is equal to the sum of the other two.
135. Two straight lines ABD , ACE touch a circle at B and C ; if DE be joined, and if DE be equal to BD and CE together; show that DE touches the circle.
136. A , B , C , D are four points on a circle; show that the four points, where the perpendiculars from any point to the straight lines AB , CD meet AC , BD , are concyclic.
137. Through a given point without a circle draw, when possible, a secant to the circle such that the part without the circle shall be equal to the part of it within the circle.
138. Show that, if from any point in a given arc of a circle perpendiculars be let fall on the radii to its extremities, the line joining the feet of these perpendiculars will be of constant length.

139. ABC is a right-angled triangle; from any point D in the hypotenuse BC a straight line is drawn at right angles to BC, meeting CA at E and BA produced at F; show that the square on DE is equal to the difference of the rectangles BD. DC and AE. EC; and that the square on DF is equal to the sum of the rectangles BD. DC and AF. FB.
140. A and B are two fixed points in a diameter of a circle, equidistant from the centre C; through A any chord XAY is drawn, and its extremities are joined to B; show that the sum of the squares on the sides of the triangle BXY is constant.
141. AB and CD are parallel chords of a circle and E is the middle point of AB. Show that, if DE meet the circle again in P, PA and PB are tangents to the circles CAE, CBE respectively.
142. From a given point without a circle, whose centre is O, draw a straight line to cut the circumference in P and Q so that the triangle OPQ may be the greatest possible.
143. If two pairs of opposite sides of a hexagon inscribed in a circle be parallel, the third pair will also be parallel.
144. AB is a chord and AC an equal length on the tangent at A to a circle ABM; BC, produced if necessary, cuts the circle again in D, and M is the middle point of the arc cut off by AB and on the side remote from C; show that ACDM is a parallelogram.
145. ABC is any triangle inscribed in a circle, and AP, BQ are chords of the circle parallel to BC, CA respectively; show that PQ is parallel to the tangent at C.
146. The bisectors of the angles of the triangle ABC inscribed in a circle meet in a point O and cut the circle again in P, Q, R respectively; show that O is the orthocentre of the triangle PQR.
147. A, B are the points of intersection of two given circles, and any other circle through A cuts the given circles again in C, D respectively. Show that if any line through B cut the circles ACB, ADB in E, F respectively, the lines CE, FD will intersect on the circle CAD.
148. If from the extremities of a diameter AB of a semi-circle, two chords AD, BE be drawn, meeting in C, then $AC \cdot AD + BC \cdot BE = AB^2$
149. If a quadrilateral be inscribed in a circle, and a straight line be drawn making equal angles with one pair of opposite sides, it will make equal angles with the other pair.

150. CD is a perpendicular from any point C in a semi-circle on the diameter AB ; EFG is a circle touching DB in E , CD in F , and the semi-circle in G ; prove—(1) that the points A , F , G are collinear, (2) that $AC=AE$.
151. Three circles BCO , CAO , ABO meet in a point O , and from any point D on the circle BCO , the lines DB , DC are drawn to cut the circles ABO , CAO in F , E respectively: show that EAF is a straight line. Show also that the lines joining the centres of the three circles form a triangle equiangular to the triangle DEF .
152. P and Q are points one on each of two concentric circles, and the tangents at P , Q meet in T ; show that, if the line joining T to the centre of the circles bisects PQ , the tangents at P and Q must be at right angles.
153. Draw a chord in a semi-circle parallel to its diameter AB , so as to subtend a right angle at a given point in AB .
154. If about a quadrilateral another quadrilateral can be described such that every two of its adjacent sides are equally inclined to that side of the former quadrilateral which meets them both, then a circle may be described about the former quadrilateral.
155. E is the middle point of a semi-circular arc AEB , and CDE is any chord cutting the diameter at D , and the circle at C : show that the square on CE is twice the quadrilateral $AEBC$.
156. If three circles intersect one another, two and two, the common chords shall meet in a point.
157. On the same chord and on the same side of it two arcs of circles are described each greater than a semi-circle; show how to draw from one extremity of the chord a straight line cutting both the arcs so that the rectangle contained by the segments may be the greatest possible.
158. Find a point in the diameter of a circle produced, so that the tangent from it to the circle may be twice the part of the secant beyond the circle.
159. If a circle touch a semi-circle in D and its diameter in P , and PE be perpendicular to the diameter at P to meet the semi-circle in E , the square on PE is equal to twice the rectangle contained by the radii of the circles.

160. If a circle PGD touch a circle ABC in D and a chord AB in P, and if EF be drawn perpendicular to AB from its middle point E and at the side opposite to that of the circle PGD, so as to meet the circumference in F, the rectangle contained by EF and the diameter of the circle PGD is equal to the rectangle AP.PB.
161. Find a point such that if perpendiculars be drawn from it to four given lines, the feet of these perpendiculars may be collinear.
162. Two equal circles are so placed that the tangent to either from the centre of the other is equal to a diameter; show that the common tangents are each equal to a radius.
163. Draw a straight line from one circle to another, to be equal and parallel to a given straight line.
164. AB and CD are two chords of a circle cutting at a point E within the circle; AB is produced to H so that BH is equal to BE. The circles AEC and ACH cut BC in K and L; prove that B is the middle point of KL.
165. If from any point in the diameter of a circle straight lines are drawn to the extremities of a parallel chord, the squares on the straight lines are together equal to the squares on the segments into which the diameter is divided.
166. AB is a fixed diameter of a circle, and C a fixed point in AB; in the circle place a chord parallel to AB to subtend a right angle at C.
167. A and B are two fixed points without a circle PQR; find a point P in the circumference, so that the sum of the squares described on AP and BP may be the least possible.
168. AB and CD are two parallel chords of a circle; AC, BD intersect in E, and AD, BC in F, show that EF passes through the centre.
169. Circles are described on the sides of a quadrilateral as diameters; show that the common chord of any adjacent two is parallel to the common chord of the other two.
170. The four circles circumscribing the four triangles formed by four given straight lines, no two of which are parallel, have a common point of intersection.
171. If the straight line joining the centres of two circles, which are external to each other, cut them in the points A, B, C, D, the squares on the common tangents to the two circles are equal to the rectangles BD. AC and BC. AD.

172. A, B, C are any three points on the circumference of a circle; if the tangents at B and C meet in O, the line through O parallel to AB meets AC in the diameter perpendicular to AB.
173. Find the point in the circumference of a given circle, the sum of whose distances from two given straight lines at right angles to each other, which do not cut the circle, is the greatest or least possible.
174. ABC is a triangle inscribed in a circle; AD is the diameter of the circle through A; if O be the orthocentre, prove that CD is equal to BO.
175. O is the middle point of the chord AB of a circle and PQ is any chord through O. Show that AB produced cuts the tangents at P and Q in points equidistant from the centre.
176. O, O' are the centres of two circles which touch each other at A, and B is the middle point of OO'. Through a point P on the tangent at A a line is drawn perpendicular to PB; show that the two circles intercept equal chords on this straight line.
177. Through two given points in the circumference of a given circle draw two parallel chords of the circle which shall contain the greatest rectangle.
178. Through a given point O within a circle draw a chord AOB such that the difference between AO and OB may be equal to a given straight line.
179. The circles whose diameters are the four sides of any cyclic quadrilateral intersect again in four concyclic points.
180. The square on the perpendicular from any point in the circumference of a circle, on the chord of contact of two tangents, is equal to the rectangle of the perpendiculars from the same point on the tangents.
181. A series of circles touch a fixed straight line at a fixed point; show that the tangents at the points where they cut a parallel fixed straight line all touch a fixed circle.
182. The rectangle contained by the perpendiculars from any point in a circle, on the diagonals of an inscribed quadrilateral, is equal to the rectangle contained by the perpendiculars from the same point on either pair of opposite sides.
183. If through the point of intersection of the diagonals of a cyclic quadrilateral the least chord be drawn, that point will bisect the part of the chord between the opposite sides of the quadrilateral.

184. Two circles cut each other at right angles at A, B ; P is any point on one of the circles, and PA, PB cut the other circle in Q, R , respectively: show that QR is a diameter.
185. Two circles cut each other at right angles, and tangents are drawn to one of the circles from any point on the other; prove that the middle point of the chord of contact of these tangents is on the second circle.
186. $ABCD$ is a quadrilateral inscribed in a circle; the sides AB, CD produced intersect at P , and AD, BC at Q ; show that the straight lines which respectively bisect the angles APC, AQC are perpendicular to each other.
187. Four given points in a plane are joined two and two by three pairs of straight lines. Show that, if the bisectors of the angles between any one of these pairs be parallel to the bisectors of the angles between either of the other pairs, the four given points must be cyclic.
188. Through a point on a circle any three chords are drawn; prove that the circles described on these chords as diameters will intersect again in three points in a straight line.
189. Show that, if from the middle point of each side of a quadrilateral inscribed in a circle a perpendicular be drawn to the opposite side, these four perpendiculars will meet in a point.
190. If two circles touch in C , and if D be any point outside the circles at which their radii through C subtend equal angles, and if DE, DF be tangents from D , $DE \cdot DF = DC^2$.
191. Through the centre of the circle circumscribing the triangle ABC lines are drawn parallel to AB, AC , meeting the tangents at B, C respectively in E, F . Show that EF touches the circle.
192. A point P on one given circle is joined to a point Q on another given circle; show that there is one, and only one, other line which is equal and parallel to PQ and which has its extremities one on each of the given circles.
193. A and B are two points one on each of two given circles. Draw through A and B two equal and parallel chords.
194. From any point T the tangents TP, TQ are drawn to a circle and TR, TS are drawn to a concentric circle. Show that PR, PS makes equal angles with the tangent at P .
195. Show also that the lines PR, PS, QR, QS touch two circles whose centres are respectively T and the centre of the given circles.

196. The line joining any point P , in the circumference of a circle, to the point of intersection of the perpendiculars of an inscribed triangle, is bisected by the line joining the feet of the perpendiculars from P on the sides of the triangle.
197. The circle whose diameter is the third diagonal of a quadrilateral inscribed in another circle, cuts the latter orthogonally.
198. If an arc of a circle be divided into two equal, and into two unequal parts, the rectangle contained by the chords of the unequal parts, together with the square on the chord of the arc between the points of section, is equal to the square on the chord of half the arc.
199. Two circles whose centres are A and B intersect at right angles, and their common chord meets AB in O ; if CD is any chord of the first circle passing through B , show that the four points A , C , D , O are concyclic.
200. A and B are the centres of two circles which touch internally at C , and also touch a third circle, whose centre is D , externally and internally respectively at E and F ; show that the angle ADB is double of the angle ECF .
201. In a cyclic quadrilateral, whose diagonals are at right angles, the feet of the perpendiculars from the point of intersection of the diagonals on the sides, and the middle points of the sides all lie on a circle.
202. The opposite sides of an inscribed quadrilateral are produced to meet in P , Q ; show that the square on PQ equals the sum of the squares of the tangents from P and Q to the circle.
203. $ABCD$ is a cyclic quadrilateral; AD and CB meet in Q , AB and CD in R ; if O be the centre of the circumscribed circle, show that the square on QR , with twice the square on the radius of the circle, is equal to the sum of the squares on QO , RO .
204. $ABCD$ is a parallelogram; AE is at right angles to AB , and CE is at right angles to CB : show that ED , if produced, will cut AC at right angles.
205. In an acute angled triangle ABC , perpendiculars AD , BE are let fall on BC , CA respectively; the circle described on AC as diameter cuts BE at F and G , and the circle described on BC as diameter cuts AD at H and K ; show that the points F , G , H , K are concyclic.

206. From a point P outside a circle two secants PAB , PCD are drawn to the circle $ABCD$; AC , BD are joined and intersect at O , prove that O lies in the chord of contact of the tangents drawn through P to the circle.
207. If two sides of a given triangle pass through fixed points, the third touches a fixed circle.
208. If two sides of a given triangle touch fixed circles, the third touches a fixed circle.
209. Four common tangents are drawn to two circles which are external to each other; show that the two direct and the two transverse tangents intersect on the line joining the centres of the circles.
210. If the tangents from a given point to any number of intersecting circles are equal, all the common chords of the circles pass through that point.
211. Two circles intersect at A , B , and at A tangents are drawn to each circle to meet the circumferences in P , Q ; show that the triangles ABP , ABQ are equiangular.
212. Show that, if AC and BD are parallel chords of a circle, and if O is the point of intersection of AB and CD , the two circles OAC , OBD will touch each other.
213. Through a given point within a given circle draw a chord that is divided at the point in medial section.
214. Through A , one of the points of intersection of two given circles, draw a line PAQ cutting the circles in P , Q respectively, so that the difference between AP and AQ may be equal to a given line.
215. Show that if O be taken within a parallelogram $ABCD$ such that the angles OBA , ODA are equal, the circles circumscribing AOB , BOC , COD and DOC will all be equal.

LOCI.

1. Find the locus of the centres of all circles which touch two given intersecting straight lines.
2. Find the locus of the centres of all circles which touch a given straight line at a given point.
3. Find the locus of the centres of all circles with a given radius which touch a given straight line.

4. Find the locus of a point from which the tangents to a given circle shall be of a given length.
5. Find the locus of a point such that tangents drawn from it to a given circle may contain a given angle.
6. Find the locus of the points of contact of tangents from the point A to all circles whose centre is B.
7. Find the locus of the middle points of all chords of a circle drawn through a given point.
8. Find the locus of the vertex of a triangle, having given the base and vertical angle.
9. Find the locus of the centre of the circumscribed circle of a triangle, having given the base and vertical angle.
10. Find the locus of the centre of the inscribed circle of a triangle, having given the base and vertical angle.
11. Find the locus of the orthocentre of a triangle, having given the base and vertical angle.
12. Find the locus of the centroid of a triangle, having given the base and vertical angle.
13. Find the locus of a point from which the tangents to two intersecting circles are equal.
14. Find the locus of the point of intersection of equal tangents to two circles.
15. Two opposite corners of a square move on two lines at right angles ; find the loci of the other corners.
16. Find the locus of the corners of a rectangle formed by drawing the sides parallel to and through the extremities of two chords of a circle at right angles to each other.
17. PQ a line of given length slides between two given lines OP, OQ ; PX, QX are perpendiculars to OP, OQ respectively, find the locus of X.
18. Two circles whose centres are A and B intersect at D ; through D a chord PDQ is drawn meeting the circles at P and Q respectively ; PA and QB intersect at C, find the locus of C.
19. Find the locus of the middle points of all lines drawn from a fixed point to meet a fixed circle.
20. If O, C be any fixed points on the circumference of a circle, and OA any chord ; if AC be joined and produced to B, so that OB is equal to OA, find the locus of B.
21. If two equal circles intersect, each is the locus of the orthocentre of triangles inscribed in the other on the common chord as base.

22. A circle of given radius moves so as to cut a fixed circle in two points which always lie in a straight line with a given point, find the locus of the centre of the former circle.
23. AB is a fixed chord of a circle and CD any chord bisected by AB , find the locus of the intersection of tangents at C and D .
24. In a circle two chords of given length are drawn so as not to intersect, and one of them is fixed in position; the opposite extremities are joined by straight lines; find the locus of their intersection.
25. D is a point on the arc BC of the circum-circle of an equilateral triangle ABC . BE is drawn parallel to CD to meet AD in E ; find the locus of E .
26. If ABC be an equilateral triangle, find the locus of P , if $PA = PB + PC$.
27. AB is a fixed chord in a given circle, and from any point C in the arc ACB , a perpendicular CD is drawn to AB . With C as centre and CD as radius a circle is described, and from A and B tangents are drawn to this circle which meet at P ; find the locus of P .
28. OA, OB are two fixed radii of a given circle at right angles to each other, and POQ a variable diameter; find the locus of the intersection of PA, QB .
29. O is a fixed point; P any point on a given circle. From O is drawn OQ equal to OP and making the angle POQ equal to a given angle; find the locus of Q .
30. If P and Q be two fixed points, and R move so that the perpendicular from P on QR bisects QR , find the locus of R .
31. AB is a fixed chord in a circle; PQ another chord of given length; AP, BQ meet in R ; find the locus of R .
32. If A be a fixed point and PD a fixed line, and if any point P in PD be joined to A , and a point Q be taken on AP so that the rectangle $AP.AQ$ is constant, find the locus of Q .
33. From any point P on a given circle is drawn a straight line PQ equal and parallel to a given finite straight line; find the locus of Q .
34. If the feet of the perpendiculars drawn from any point P to the sides of the triangle ABC be collinear, find the locus of P .
35. Four fixed points A, B, C, D are taken on a circle, and two other circles are drawn to touch each other, one circle passing through A, B , and the other through C, D . Find the locus of their point of contact.

36. Two segments of circles have a common chord AB , and any points P, Q are taken on their arcs, find the locus of the intersection of the bisectors of the angles PAQ, PBQ .
37. AB, AC are two tangents drawn from A to two circles which cut in O , and BC meets the circles in D, E ; if the angle BOD is equal to the angle COE , find the locus of A .
38. On a given base a triangle is described, such that one side is equal to the perpendicular from the other extremity of the base on it, find the locus of the vertex.
39. AB is a fixed chord and AC a variable chord of a fixed circle, find the locus of the middle point of BC .
40. Two circles intersect, and any straight line cuts them in A, B and C, D respectively. If E be a point on the line such that the rectangles $AC.BE$ and $BD.CE$ are equal, find the locus of E .
41. Two chords of a circle intersect at a fixed point P at right angles, find the locus of the middle points of the lines joining their extremities.
42. Find the locus of the centre of a circle which bisects the circumferences of two given circles.
43. A quadrilateral inscribed in a circle has one side fixed, and the opposite side constant; find the locus of the intersection of the other two sides, and of the intersection of the diagonals.
44. Any circle is drawn through the vertex of a given angle. Find the locus of the ends of that diameter which is parallel to the line joining the points where the circle cuts the arms of the angle.
45. Find the locus of the intersection of tangents to a circle at the extremities of a chord which passes through a fixed point.
46. A is a fixed point in the circumference of a circle and ABC an inscribed triangle such that the sum of the squares on AB, AC is constant; find the locus of the middle point of BC .
47. A is a fixed point on the circumference of a circle whose centre is O , and BOD is a diameter. The tangents at A and D meet in L ; find the locus of the intersection of LB with the perpendicular from A on OB .
48. Two circles cut each other at right angles at A ; find the locus of the middle point of the common chord.

49. Two circles cut each other in A , and from A a straight line is drawn cutting the circles again in B, C , and CA is produced to D , so that the rectangle $AD \cdot BC$ is constant; find the locus of D .
50. Two circles intersect at A , and through A any straight line BAC is drawn to meet the circumferences in B, C ; find the locus of the middle point of BC .
51. If the sum or difference of the tangents from a variable point to two circles be equal to the part of the common tangent of the two circles between the points of contact, the locus of the point is a straight line.



