

# Nikola Tesla

Discovering The Future

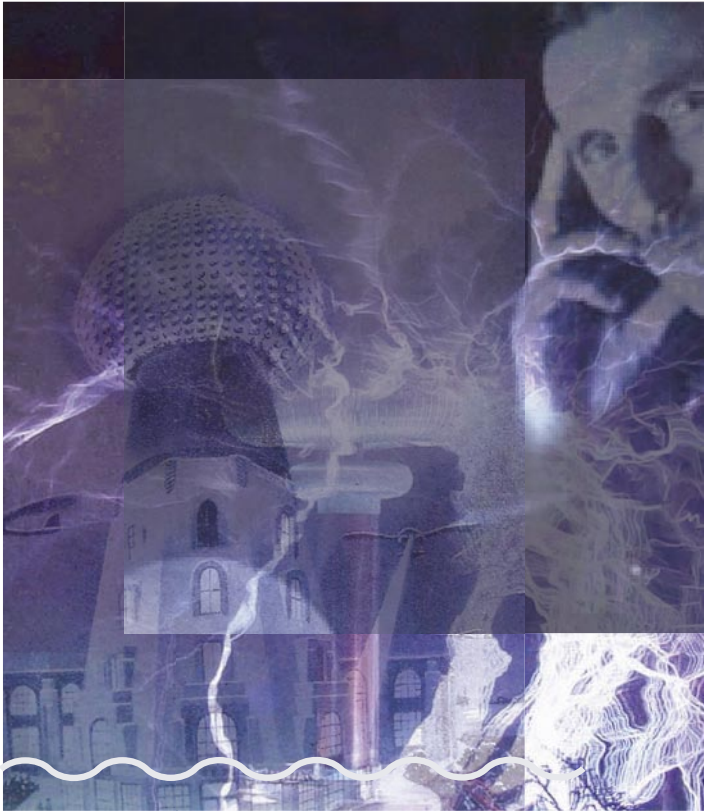

Nikola Tesla - Discovering The Future

„Let the future tell the truth,  
and evaluate each one  
according to his work and  
accomplishments.  
The present is theirs;  
the future, for which I have  
really worked, is mine,,

Nikola Tesla

---

This book does not have a table of content and is intended to be read in the order it is presented, because the later portions of this book build on the previous pages.

---

## IMPORTANT COPYRIGHT NOTICE

this book is ©2008 by swisstesla.com - all rights reserved.

The author and copyright holder herewith grants explicitly the right to copy, share and distribute this book freely subject to the following limitations:

This book must remain in its completeness and may not be reproduced or distributed partially - except for the parts that are citations of or borrowed from other sources and are marked as such.

No part of this book including this copyright notice may be deleted or altered in any way.

The book may not be copied, printed, distributed, sold or used for any commercial purpose other than intended and sanctioned by swisstesla.com.



# Nikola Tesla

## Discovering The Future

Already as a child the later physicist Nikola Tesla made extraordinary discoveries. As a young man, he started the development of the now so common system of alternating current, which has been applied in 1893 for the first time on a grand scale for power production and illumination of the world exhibition in Chicago. Around the turn of the century, Nikola Tesla was celebrated as the “man who invented the 20th century” by

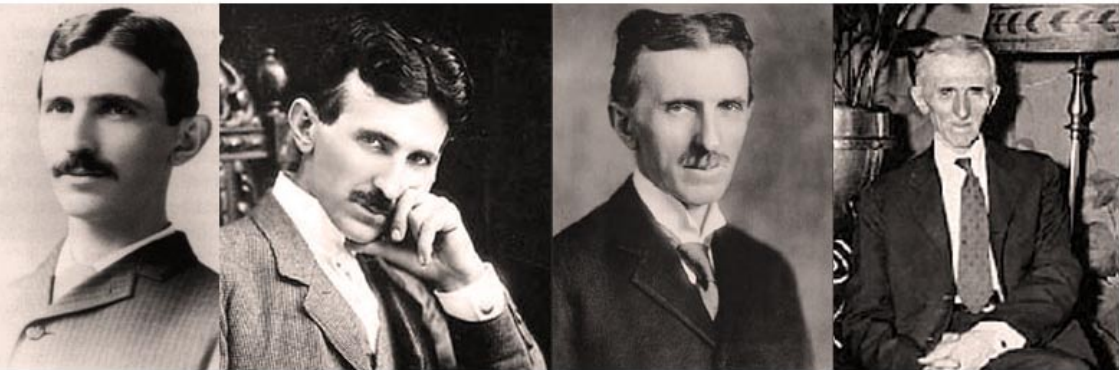

newspapers of all nations. Nikola Tesla called himself a discoverer – rather than “inventor” – and his discoveries comprise more than 700 patents in the fields of cosmic rays, radar, diathermy, the high-frequency furnace, wave-guide for microwave transmission, space navigation code, cryogenic engineering, electrotherapeutics, energy transmission to satellites, principles of solid state transistor technology, the bladeless turbine and the reciprocating dynamo. Every modern time TV, radio, computer, remote control, cell phone, fluorescent light bulb or tube and the basic powering system required to operate all of them is due to the credentials of Mr. Nikola Tesla. How could this creative mind and productive character get into oblivion for more than half a century?



Nikola Tesla was born on midnight between July 9 and 10, 1856 in the small town of Smilijan (today's Croatia) as the son of an orthodox priest and what he himself later called "a truly great woman of rare skill, courage and fortitude, who had braved the storms of life and passed through many trying experiences". After visiting the university of Graz, where he studied physics and mathematics, and the university of Prague for philosophy, he worked as an electric engineer in Budapest, Paris and Germany. After emigrating to the United States of America, where he arrived with only a few cents in his pocket, he became an assistant to the renowned inventor Thomas Edison. Their first meeting was in 1884, initiated by Charles Batchelor, who was Tesla's superior during his assignment with Continental Edison in Paris. Charles Batchelor had written to Edison: "I know only two really great men in this world: You are one of them; and young Nikola Tesla is the other."



Nikola Tesla

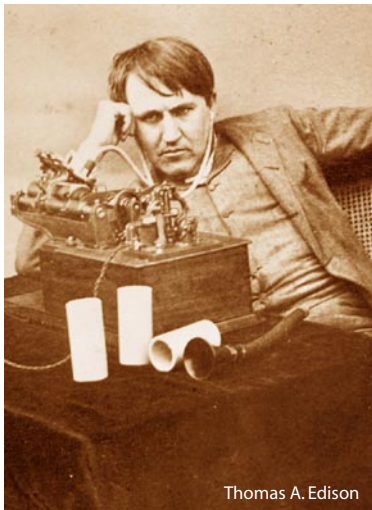

Thomas A. Edison

Edison employed Tesla as his assistant and Tesla initially admired Edison for his achievements on the basis of trial and error, as Edison had only a basic school education. On the other hand, Tesla gained Edison's reluctant respect by working eighteen hours per day during seven days a week and by solving very difficult technical problems.

But Edison soon lost his diligent new assistant. Tesla had described how he could improve the overall efficiency of Edison's generator and Edison



promised to him: "There are fifty thousand Dollars in it for you, if you can accomplish this." But when Tesla finally succeeded after months of tedious labor and asked for his money, he was shocked to hear from Edison: "Tesla, you don't understand our American sense of humor." As Edison wouldn't pay, Tesla left.

After jobbing for some while as construction worker with a crew of roadmen in New York in order to earn his living, his luck changed for the better. He got the chance to develop his system of alternating current, for which he had devised

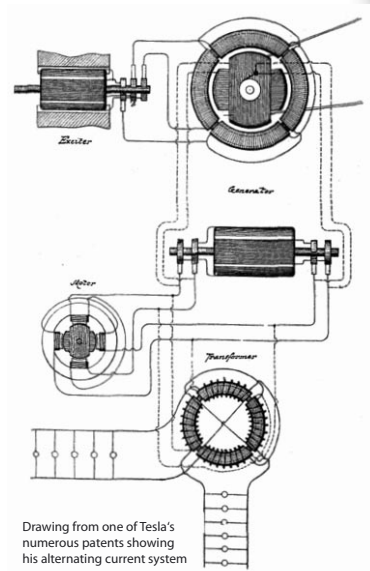

and patented a motor, a generator and a transformer. The industrialist George Westinghouse from Pittsburgh bought all patents related to this system from Nikola Tesla and signed a contract, promising him a cash advance, stocks plus three licensing fees of one Dollar each for every horsepower generated.

Edison was fighting the development of alternating current. His bulbs were operated by direct current, in which the electrons are traveling in just one direction. While direct current can be transported over only a few kilometers through wires, Tesla's high voltage alternating current that changes phase in a steady rhythm can be transported over hundreds of kilometers. On the receiving end transformers are reducing the voltage for the end user.

But Edison didn't want to acknowledge the advantages of alternating current. He had invested a lot of funds into the development of direct current and therefore considered alternating current as a threat to his business. As a means of combating Tesla's method, he publicly electrocuted dogs and published daunting pamphlets in order to depict alternating current as a deadly threat.

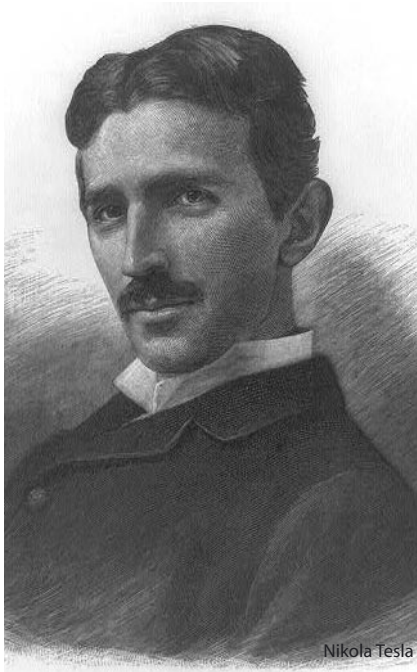

Nikola Tesla

In spite of Edison's attacks, Tesla and Westinghouse emerged as the victors and in 1893 Westinghouse installed an alternating current system for the illumination of the world exhibition in Chicago. Tesla was the headliner of the exhibition: He was onstage dressed up in white tailcoat and shoes with insulating cork soles, together with one of his Tesla coils – a device to generate very high currents. The electric sparks cracked and flashed and brought light bulbs in Tesla's hands to gleam. The crowd was exalted about this spectacle and the success of the exhibition finally led to the development of

a hydroelectric project at the Niagara Falls. Finally Tesla's electric grid supplied huge amounts of electric energy to the whole continent.

As the contract with Westinghouse granted Tesla a royalty per horsepower generated, he should have received a superb income for the rest of his life. However, George Westinghouse was getting into financial difficulties, as competitors were trying to put him out of the electricity business. Tesla remembered, that Westinghouse kept faith with him, when nobody else did and although Tesla was not averse to financial wealth, he valued the survival of Westinghouse's company as more important. So he tore the contract, accepted a severance payment and forewent the expected millions of dollars, which were granted to him by the horsepower agreement.

While Tesla tore a lucrative contract in order to help a friend, others have been into reaping maximum profits. Tycoons were getting ready to make their fortunes with electricity corporations. These men wanted to use the alternating current system to enwrap the planet with electric poles,



transformers and wires. Electricity ventures should finally retain rivers und encourage people to lead a “better life with electricity”.

Tesla himself wanted to build an energy supply system by transmitting electricity free of charge on a global scale. Although this system was not encompassing a free and inexhaustible source of energy, the means by which the electric current would be transferred to customers was intended to be free. But in contrast to the power struggle with Edison, this time Tesla could not defeat his adversaries.

As if he were blind for the plans of the monopolists, he was focusing on developing a wireless energy broadcasting system. A part of his vision was to use the planet’s own resonance. Already in 1893, the same year when he delighted society with the illumination of the world exhibition, he held a speech about the earth’s resonance before the reputable Franklin Institute in Philadelphia. The planetary resonance was constituting a part of his vision for a wireless transmission of electricity . His idea was to send electric impulses in an appropriate frequency through the earth in order to generate waves of energy, just like in a piano where a string is getting excited through resonance by the matching tune of a different instrument in the same room. Some later researchers that delved into Tesla’s work also believe, he had triggered the airspace between the upper atmosphere and the ground into resonating just like the air in the body of a violin, what also would emit waves of energy. This energy then was intended to be harnessed by a receiver.

Such a resonating system would have fulfilled Tesla’s dream, which he expressed in his speech of 1897, where

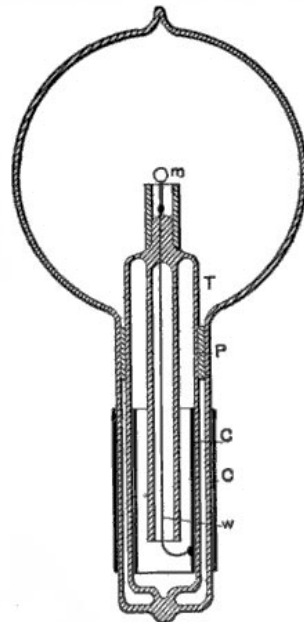

**TYPE OF BULB  
WITHOUT LEADING-IN  
WIRE.**



he talked about transmission of energy from station to station without the use of interconnecting wires. He envisioned the day where such a system would speed up exchange of news, control the weather and transfer limitless amounts of energy.

While he could have easily been distracted by fame and by his international lecturing tours, he was driven by his passion for his work and in the

consecutive years he applied for and received patents for processes of a seemingly utopian wireless transmission of energy and wireless communications – even taking the risk of thereby discarding any of his previous inventions.

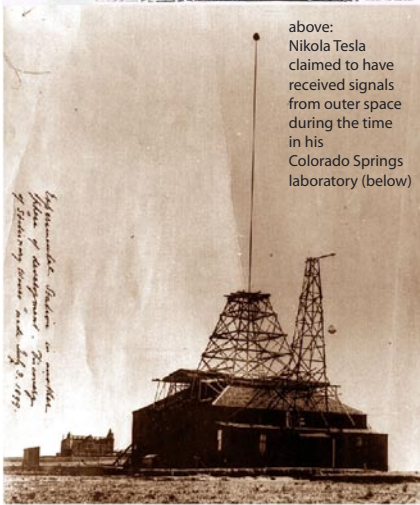

above:  
Nikola Tesla claimed to have received signals from outer space during the time in his Colorado Springs laboratory (below)

In the year 1899 Tesla retreated to the mountains of Colorado Springs in order to try out his new ideas. On a high altitude pasture he erected his high voltage laboratory. It was consisting of a simple building that enclosed the biggest Tesla coil and from which a strange pole was poking out at the top. There, at the foot of the Pikes Peak he worked for his new aim to conduct electromagnetic waves through the earth.

It is not clear, what exactly his achievements during his stay in the mountains were. Sometimes he took sparing notes, but most of the information about the underlying principles of his installations he treasured solely in his memory. Today his notes need translation into contemporary electro-technical terms, but the legends about Tesla live from the factual incidents of his experiments in Colorado Springs. Just like Thor, the Lord of the thundering bolt, he tuned his giant coil with a diameter of 16 meters in such a way, that it generated a discharge of twelve million volts and fired sparks in the length





of more than 30 meters from the copper sphere at the tip of the flagpole. The locals kept well on distance, after rumors spread, the famous inventor could generate lightning that would kill a hundred people in a single stroke. At times the resulting thundering from the electric discharge was still heard at a distance of 25 kilometers.

Contented about the acquired knowledge on wireless transmission and determined to implement his vision, he returned to New York by Janu-

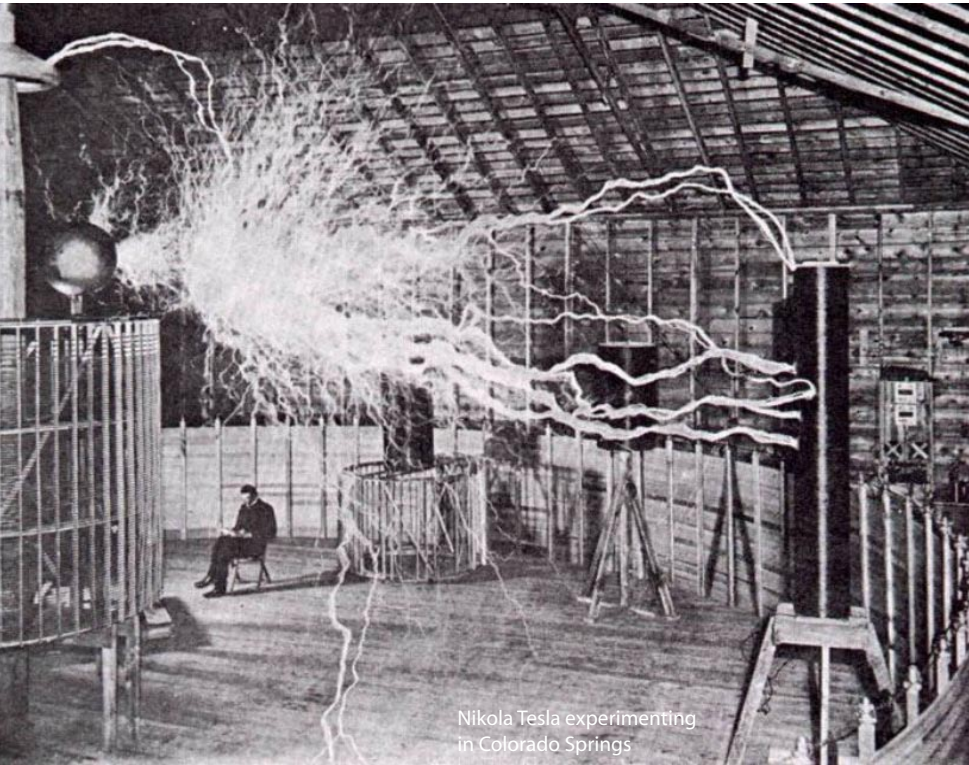

Nikola Tesla experimenting  
in Colorado Springs

ary 1900. He contracted an architect who designed him a 47 meters high wooden tower on top of a brick building on Long Island. With a mushroom shaped copper electrode as its crown, this tower should serve as an enormous transmitter. Tesla called this project Wardenclyffe and envisaged a station that would broadcast energy as well as news over several channels across the whole spectrum of radio wavelength. In 1902 the tower and a square building with a side length of thirty meters



that would accommodate a powerhouse and a laboratory were almost ready. But Wardenclyffe never reached completion.

Tesla's vision of wireless news broadcasting had convinced financiers like Morgan to fund his research. But they remained unaware of the fact that he also intended to deliver electricity to everybody everywhere free of charge. He had kept this part of his plan secret when asking Morgan, his main sponsor, to finance Wardenclyffe in 1900. Instead he highlighted the potential that would open up to Morgan by retaining the monopolistic control over all radio stations. But Morgan provided Tesla only limited funds and three years later the inventor unveiled his true intentions to the banker in a despaired request for additional funding. We will probably never know the exact

Wardenclyffe  
under  
construction



wording of Morgan's response to this revelation. However the financier had invested into industries that were associated with power production and for sure he was not known to give something away for free. He simply dropped Tesla.

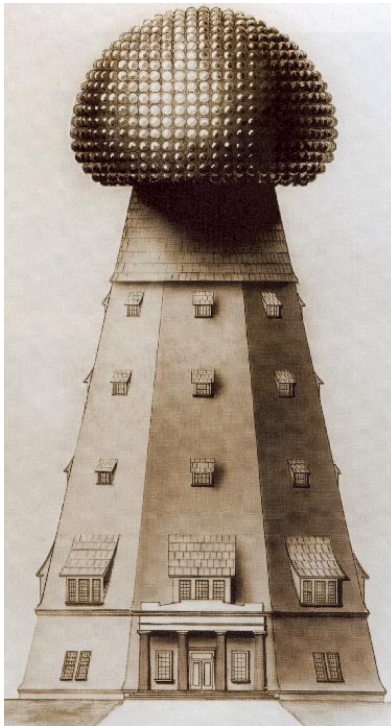

a visualisation of the completed Wardenclyffe Tower

Then work progressed only sporadically while Tesla desperately tried to find new financiers as well as to develop commercial products in order to pay for his bills. The construction finally came to a halt in 1906 and eleven years later, after Tesla had lost his mortgage on Wardenclyffe, the tower was pulled due to his scrap value.

There are indications that Tesla was interested in free energy in the modern sense of the word – free energy from an inexhaustible source, which



can be transformed into a usable form. In June 1902 the New York Times published an article about a man from Canary Islands named Clemente Figueras who claimed to have invented an electric generator that was independent from any primary (outside) force. A day after the article had appeared, Tesla wrote to his friend Robert Johnson, the publisher of the Century Magazine, that he himself had already invented such a device. And in 1934 Tesla was quoted by Times with the words: "I hope to live long enough to get a chance to place a machine in the midst of this room and to start it with nothing than the energy contained in the medium surrounding us".

Which of his many discoveries did Tesla talk about? Oliver Nichelson, scientist and historian from Utah studied this particular question in detail. He said the device that would apparently fit Tesla's description is an apparatus for the use of radiant energy that had received a patent in 1901. Nichelson's research indicates that Tesla must already have worked on a free energy generator prior to writing a longer article for the June 1900 edition of the Century Magazine, in which he described the wireless transmission of energy. He writes that a device harvesting energy directly from sunlight was not very effective and therefore not the best solution.



Nikola Tesla during his studies

Many researchers have taken this as an indication that from his Wardenclyffe experience Tesla realized that such a device would have been banned from the free market forever and the tycoons would only finance a wireless power grid, if it promised profits. The article in the Century focused on a device that was not only able to sustain its own functioning, but would also draw energy from the surrounding air in order to illuminate entire cities. Nichelson identified Tesla's electromagnetic coil, for which



Tesla was granted patent no. 512.340, as the most probable candidate able to draw energy from the cosmos. Nicolson explains that the shape of the coil would allow the system to store huge amounts of energy, while it consumes only a fraction of this energy to sustain its own operation. He compares it to a car with a very large tank that uses only two liters per 100 kilometers.

While nowadays many physicists know Tesla only as the discoverer of the magnetic Field force [ $1T=1N/(1A*1m)$ ], this was totally different during Tesla's lifetime. He was a real star, celebrated by media and the public. An engineer with unflinching inventive talent: The man who discovered the 20th Century! An inexhaustible source of novel inventions of which each and every one wrote history and would ease our daily life up to date. Though his greatest and at the same time least understood discovery was the cosmic energy and its usability. Would he have been allowed to conclude his life task, our world energy problem would be nonexistent today!

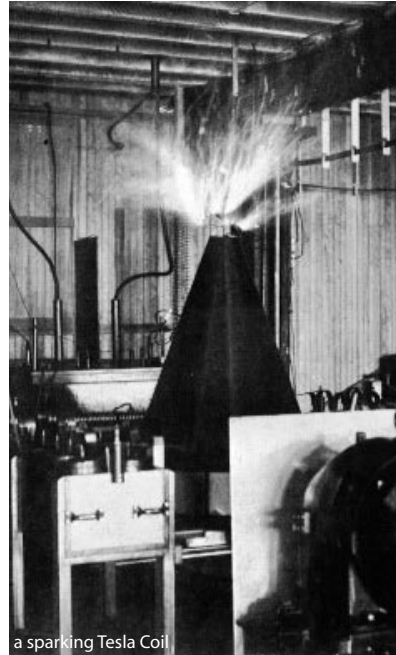

a sparking Tesla Coil

The discovery of the utilization of cosmic energy by Nikola Tesla is dating back to an American patent issued around the turn of the century. This form of energy is therein called Radiant Energy. The Patent shows a special receiver and a corresponding condenser to harvest this cosmic energy. Tesla was absolutely convinced of the usability of the cosmic energy and therefore developed many of his ideas with private funding.

When his receiver for the free energy finally worked efficiently, he followed the idea of implementing it into a big heavy luxury sedan car as its driving power. For the realization of this project he could eventually get financial support from George Westinghouse and count on the technical



collaboration with the Pierce Arrow Motor Car Company in Buffalo, N.Y.

He replaced the petrol engine of a classic Pierce Arrow 1931 model with an air cooled electrical motor producing 80 hp at 1800 rpm. This engine was measuring 40 inches length by 30 inches width (approx. 100 x 76 cm). The connective wires for the power supply were not plugged into any battery; there was no visible outer source of power. He fixed his energy receiver under the dashboard and explained that the converter was producing sufficient energy to power up a whole house or to drive the car. The car was tested during a full week and was easily reaching speeds up to 90 miles (144 km) per hour.



1931 Pierce-Arrow 8 Model 43 D.C. Phaeton

The test results confirmed the Arrow's performance to be at least equivalent to a car fitted with a petrol engine, but without the need for fuel and without emitting fumes. Various newspapers in Buffalo reported the sensational news. Questions regarding the origin of its operating power Tesla just answered: "Ether which permeates everything! This energy is available as an inexhaustible supply."

But ultimately the free energy car should remain just one of his pastimes. Because Nikola Tesla knew that its time had not yet arrived. He was aware that such progress would neither find a wider acceptance than his previous discoveries of a wireless energy supply to every household.



Tesla was therefore hardly ready to share the technology as applied in the Arrow with engineers, theoretical scientists or corporations.

To the public it might appear just a coincidence, but insiders consider the shutdown of the Pierce Arrow Motor Car Company as just another cue for an existing conspiracy against Nikola Tesla and his efforts to gift his knowledge of free energy to the world. So it happened that just a few months after the successful conclusion of tests in the Pierce Arrow's factory compound in Buffalo, N.Y. the production of this brand of cars was phased out forever.

Nikola Tesla passed away on January 7, 1943 at the age of eighty-six. By this time, most of his inventions and theories have been either forgotten or discarded. His grandiose plan to supply the world with free unlimited energy had been put off. Financial deprivation and the predominant opposition that led to his downfall had to be faced by many later inventors and admirers of Tesla as well.



Nikola Tesla with  
King Peter of Yugoslavia  
in the Hotel New Yorker, 1942

After his death the tycoons really tried to erase the public memory of Tesla's genius, a strategy that did not completely succeed. Today almost every larger bookstore keeps his biography and since the late sixties the inventors and scientists interest for Tesla and his work is experiencing a revival. Much information about his technology, theories and inventions



is now shared through the internet and Tesla has become somewhat like the father of the movement on the quest for renewable clean energy.



Nikola Tesla was a humble person who was driven by his desire to contribute great solutions to humanity. This however did not fit the concept of the lobbying industry that considered him a threat to their high profits based on monopolistic structures.



In April 1921 the American Magazine published an Interview with the title "Let your imagination work for you", wherein Nikola Tesla had given an insight into his remarkable skills to the journalist M.K. Wisheart:

*In my boyhood I suffered from a peculiar affliction due to the appearance of images, often accompanied by strong flashes of light, which marred the sight of real objects and interfered with my thoughts and action. They were pictures of things and scenes which I had really seen, never of those imagined. When a word was spoken to me the image of the object it designated would present itself vividly to my vision and sometimes I was quite unable to distinguish whether what I saw was tangible or not. This caused me great discomfort and anxiety. [...] To free myself of these tormenting appearances, I tried to concentrate my mind on something else I had seen, and in this way I would often obtain temporary relief; but in order to get it I had to conjure continuously new images. It was not long before I found that I had exhausted all of those at my command; my 'reel' had run out as it were, because I had seen little of the world – only objects in my home and the immediate surroundings. As I performed these mental operations for the second or third time, in order to chase the appearances from my vision, the remedy gradually lost all its force. Then I instinctively commenced to make excursions beyond the limits of the small world of which I had knowledge, and I saw new scenes. These were at first very blurred and indistrict, and would flit away when I tried to concentrate my attention upon them. They gained in strength and distinctness and finally asumed the concreteness of real things. I soon discovered that my best comfort was attained if I simply went on in my vision further and further, getting new impressions all the time, and so I began to travel; of course, in my mind. Every night, (and sometimes during the day), when alone, I would start on my journeys – see new places, cities and countries, live there, meet people and make friendships and acquaintances and, however unbelievable, it is a fact that they were just as dear to me as those in actual life, and not a bit less intense in their manifestations.*

*This I did constantly until I was about seventeen, when my thoughts turned seriously to invention. Then I observed to my delight that I could visualise with the greatest facility. I needed no models, drawings or*





*experiment. I could picture them all as real in my mind. Thus I have been led unconsciously to evolve what I consider a new method of materialising inventive concepts and ideas, which is radially opposite to the purely experimental and is in my opinion ever so much more expeditious and efficient.*

*The moment one constructs a device to carry into practice a crude idea, he finds himself unavoidably engrossed with the details of the apparatus. As he goes on improving and reconstructing, his force of concentration diminishes and he loses sight of the great underlying principle. Results may be obtained, but always at the sacrifice of quality. My method is different. I do not rush into actual work. When I get an idea, I start at once building it up in my imagination. I change the construction, make improvements and operate the device in my mind. It is absolutely immaterial to me whether I run my turbine in thought or test it in my shop. I even note*

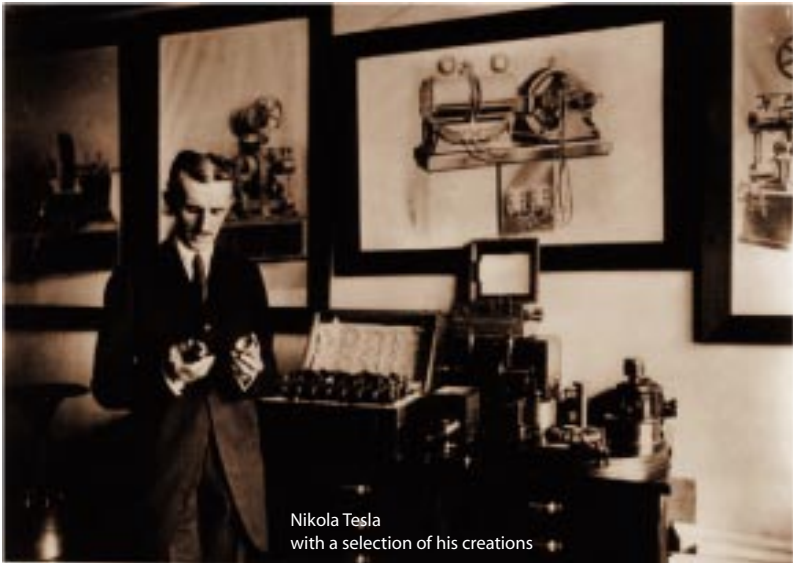

Nikola Tesla  
with a selection of his creations

*if it is out of balance. There is no difference whatever; the results are the same. In this way I am able to rapidly develop and perfect a conception without touching anything. When I have gone so far as to embody in the invention every possible improvement I can think of and see no fault anywhere, I put into concrete form this final product of my brain. Invariably*



*my device works as I conceived that it should, and the experiment comes out exactly as I planned it. In twenty years there has not been a single exception. Why should it be otherwise?*

An Excellent description of his personality – entirely meeting the taste of the late nineteenth century – is found in an article that has been published by Franklin Chester on August 22, 1897 in *The Citizen*. He characterized the inventor there with the following words:

*As far as Nikola Tesla's appearance is concerned, nobody can look up to him without feeling his power. He is far beyond six feet tall and very slender. And still he is in possession of enormous physical strength. His*

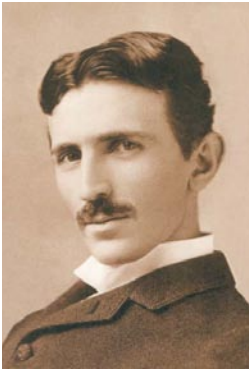

*hands are very large and his thumbs very long, what always indicates great intelligence. He wears his even black hair – a deeper shinier black is hardly conceivable – sharply combed to the back, what accents the angularity of his face even more. His cheekbones are – a characteristic to the Slavic people – high and distinct. His skin has the tone of marble with a first trace of yellow acquired through ageing. His deep-set eyes are blue and blaze like a fire. It seems as if they comprised the same eerie sparkles that*

*dash out of his appliances. His energetic head tapers off and his chin is almost just a dot.*

*Never has a man been fulfilled with higher ideals. Never has a man been working so consistently, sincerely and selflessly for the welfare of the human race. Money hardly has any significance for him. Had he decided to follow suit with Edison, he would by now probably be the richest man on earth – at his age of just forty. What distinguishes him most is his sobriety. Tesla without doubt is the most sober-minded person in New York. And still he has a sharp sense of humor und moreover the most marvelous manners. In true humbleness nobody can outdo him. Every jealousy is extrinsic to him. Never he belittled someone's achievement, never he has been short of appreciation.*



*When he speaks one simply must listen. Even somebody who does not understand what his speech is about has to listen attentively. Even the one who does not understand the importance of his words will feel the meaning. He speaks the English of a highly educated foreigner; without accent and free of mistake. Further he masters eight other languages. Since this man has arrived in New York, virtually nothing has changed with his daily routines. He lives in The Gerlach, a small and very quiet hotel on the 27th Street, between Broadway and Sixth Avenue. Every Morning at nine he leaves for his laboratory where he spends his day in his uncanny mysterious world searching for new insights and for novel energies. He tolerates no spectators during his work. Nothing is known about his assistants. From time to time he hosts a public presentation of his experiments and there are not few people ready to make every sacrifice to be admitted to such an occasion.*

*Usually he works until six but it happens that he stays longer in the laboratory. Darkness does not present an obstacle for him. He produces his own daylight. At eight o'clock sharp he arrives at the Waldorf in impeccable evening attire. In winter he always wears a swallow-tailed coat instead of a dinner jacket. Sharp at ten he gets up from his table and either proceeds to his hotel where he deepens his studies or returns back to his laboratory where he continues his work for the rest of the night.*



Mark Twain

In the late 19th century nobody of New York's upper crust had been celebrated more than the inventor Nikola Tesla. Tesla held court in his laboratory where his friends such as Samuel Clemens – better known as Mark Twain – posed for the very first photographs that were illuminated with gas discharge tubes. In amazement and with open mouth they stared into the center of the room where long sparkles discharged from Tesla's special high frequency transformers with cracking noise. Sometimes their host posed under a shower of sparks while a gas tube without connected wires lit up in his hands. And Tesla's creativity



and his intellect attracted other stars of the cultural scene to the dining halls of hotels and to private saloons, among them writer Rudyard Kipling, architect Stanford White, pianist Ignace Paderewski and writer John Muir.

Tesla was a man of contradictions, cool and aloof, but charming. Although he was a loner, he knew to sell himself. Slender and tall, always perfectly dressed, he attracted attention through his aristocratic posture and his elegance. His most striking attribute was his personal magnetism – a combination of the appealing appearance of his dark type, intensive blue eyes and a mystical aura. The world seemed to be predestined to be at his feet.

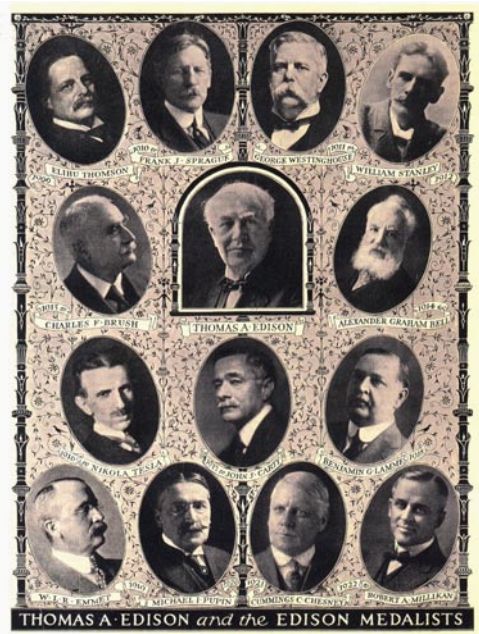

However, it seems that it had been decided in an early stage of the 20th century to not only boycott Tesla financially, but also to remove him from the history of the United States and to adopt Edison officially as father of the electrical age. There is nothing that argues against giving credit to Edison who had been very productive and who has contributed much to the era of electrification – he really deserves recognition.

But the blatant difference in how Edison and Tesla have been treated represents a chapter of a bigger context where a group tries – motivated by self-interest

– to manipulate public opinion. Edison's significance has been raised by a massive public relations effort. In 1929 more than 50 members of the military and industrial elite – amongst them John D. Rockefeller jr., Julius Rosenwald, Henry Ford, Harvey S. Firestone, Herbert Hoover and General John H. Pershing – founded a committee to mark the centenary of light and to celebrate what was called "a worldwide expression of



gratitude to Thomas Alva Edison at the 50th anniversary of the invention of his electric bulb”.

As a part of this celebration, the popular songwriter George M. Cohan wrote the song *Thomas A. Edison: Wonderman* - arranged with glorifying lyrics. This song was distributed to officials and educators accompanied by a letter stating that this song was a “tribute to the greatest living American”.

The feelings of the public would maybe have taken a different direction if they were told, that it was Nikola Tesla who wanted to supply them with free electric energy. But opposed to the hymns on Edison, Tesla never was honored by such a committee. And while some reference works focused on his work, others turned their attention to his personal originalities. Isaac Asimov's *Biographical Encyclopedia of Science and Technology* for example recapitulates 25 years with the sentence: “The last quarter of his [Tesla's] life degenerated in wild eccentricities.” (which was answered by a contemporary researcher with the notion: “we all should be this wild”).

Edison is probably not the only inventor that has been raised at the cost of Tesla. The American educational books for example ignore a decree of the Supreme Court of the United States against Guglielmo Marconi in favor of Nikola Tesla. 1901 when Marconi sent a radio signal over the Atlantic Ocean Tesla said: “Shall he just go ahead. He is using 17 of my patents.”

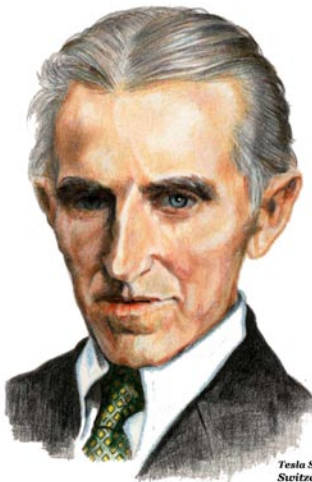

Tesla Society  
Switzerland

While some of Tesla's followers continue his research, others are trying to assure that he is not forgotten by later generations. John Wagner, a teacher from Dexter, Michigan, campaigns for Tesla and against the official historiography's only notion of Tesla's progressive crankiness during older age. Before Wagner's retirement in 1993 he had been teaching for ten years about Tesla and his achievements during his heights, instead of concentrating on the evening of the man's life. Wagner wanted his 3rd year students to know the entire history including the



fact, that the Smithsonian Institute, the national museum in Washington, does not display any permanent Tesla-exhibition.

His students recognized the double injustice in the fact that the Smithsonian Institute not only has no Tesla exhibition, but that the multiphase generator is being displayed in the large permanent exhibition dedicated to Tomas A. Edison, and that is truly one of Tesla's inventions. It clearly states the patent number, but the public is given the impression that its creator was Edison.

1943, after Tesla's dead, the Supreme Court has somewhat rectified the facts by acknowledging Tesla as one of the three most significant inventors of the century and that it was him who had patented circuits



for the radio receiver before Marconi. But in the schoolbooks and other historic documentation it is still Marconi who is portrayed as the father of the radio. A recent publication of the Smithsonian Institute: the Book of Inventions contains a paragraph about the radio. In defiance of the decision of the Supreme Court Tesla's work is not recognized. Wagner's students campaigned with a T-shirt stating "bust the Smithsonian" but when they offered to donate a Tesla bust to the Smithsonian, the curator of the electricity section, Barney S. Finn, refused the gift with the words: "we don't have any use for it". In 1979 Finn and his staff published a booklet with the title: Edison - Lighting a Revolution. Therein a seventeen pages paragraph headed "The Beginning of the Electric Age" is pretending to list all celebrities of the beginning electrical era, even technicians that worked for Edison are listed. But there is no single word about Tesla.



In the rock band TESLA that was shown on MTV waggling pages out of Tesla's patent specifications, Wagner's students found an unexpected ally. The teacher sent them a letter pleading the student's case. In 1989 this letter brought the Californian band on a trip to Michigan and 28 excited youngsters squeezed into the band's tour-bus for an excursion to the University of Michigan in Ann Arbor. In the library for engineering science of the university the students showed a bust to the band, which depicts Tesla as a proud young man and that had been created with the money collected by the class of the previous year. The band agreed to have the artifact cast in bronze and offered their support to the youngster's endeavors to get the statue into the Smithsonian.

But the Smithsonian rejected all their further efforts and up to date Tesla still obtains hardly any appreciation for his achievements in the Smithsonian Institute.

But the Legend of Tesla is alive, even if he is ignored in the educational books. A hundred years after his tide of fame many new energy books



comprising aspects from his research are appearing on the shelves and a growing number of young inventors and researchers all over the planet screens his patent specifications for important clues.

Tesla's followers are organized in various groups. The biggest one is the International Tesla Society with its headquarters

in Colorado Springs, Colorado, from where it distributes books and videos and where it maintains a Tesla museum. This group counts more than 7000 members. Tesla has also inspired many newsletters and magazines.

The Russians have shown great interest in the work of Tesla. But this research has mostly happened under conditions of the cold war, therefore



publications are only few. The top physicist and Nobel prize laureate Peter Kapitsa for example is said to have spent his final years with intense studies of Tesla's scripts. Kapitsa wanted, according to the author Margaret Cheney, to contribute to Tesla's work regarding the phenomenon of the ball lightning, which built an essential part of his experimenting for the wireless transmission of energy.

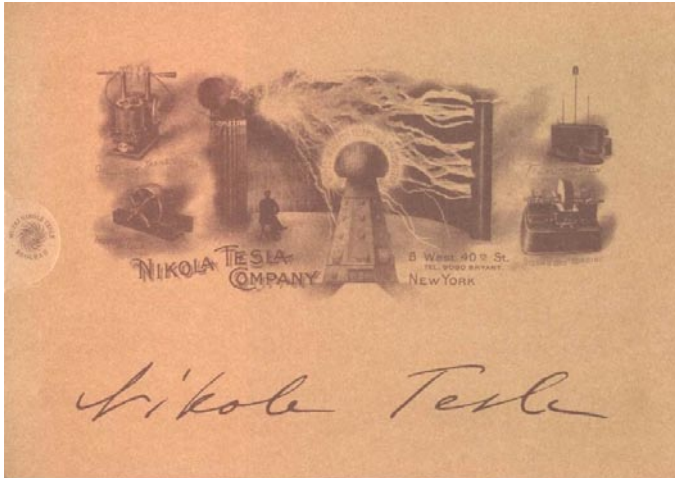

In the early seventies, scientists from the former Soviet Union dug into the Nikola-Tesla-Museum in Belgrade to examine Tesla's notes and equipment. The new energy researcher Dr. Andrew Michrovski from Ottawa heard about the extensive examinations conducted by the Academy of Sciences of the USSR when he visited the Museum in 1975. Professor Aleksandar Marincic, director of the museum showed Michrovski a heavy book in small letter print and said: "See their findings - this was just the preliminary report." Michrovski believes that the soviets could have conducted experiments with very advanced technologies as a result of their Tesla research.

It happened to the Russian physicist Dr. A.V. Chernetskij that he accidentally repeated Tesla's mishap that led to the blow of the Colorado Springs' power plant. In 1971 Chernetskij and a colleague performed an experiment that generated massive light-balls and a storm of sparks. The pulse of current, which ran through the wires of the Russian Institute for





Aeronautics, overcharged and destroyed a complete substation. This happened when they were trying to construct a device along Tesla's concepts, which should deliver more energy than it consumes.

There exists a lasting interest for Tesla's conceptual designs for a wireless transmission of electric energy. It constitutes an issue for discussion on international free energy conferences and various groups such as the Institute for New Energy located in Salt Lake City, Utah, continue with this research.

Other researchers show interest in Tesla's work regarding the planetary resonance. Tesla's followers awesomely look back on his experiments with strong electromagnetic pulses, which oscillate around the earth and simultaneously grow in strength. The leading researcher Ron Kovac from Colorado found out, that Tesla's equipment could indeed produce very strong resonances within the earth, but he points out, that today's researchers were just about to start grasping Tesla's work.

Another of Tesla's creations, which is being arduously advanced by contemporary researchers, is his bladeless turbine. Turbines that are driven by a jet of air, water or steam are common components of conventional power generating systems. But Tesla's turbine is of higher efficiency, simpler construction and is therefore more durable. It can recover additional energy from waste heat created by a conventional turbine or from other kinds of degraded energy as appears in oil and gas refinery plants.

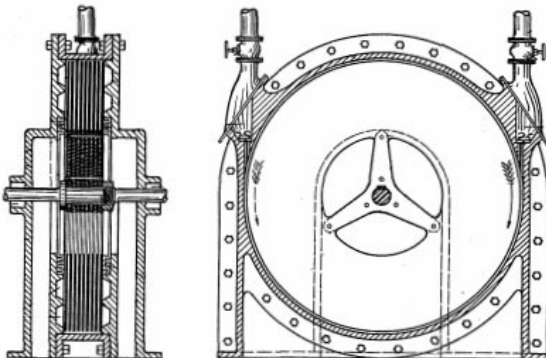

Tesla Turbine

The researcher Jeff Hayes, founder of the Tesla turbine constructor's association in Milwaukee, Wisconsin, remarks that car manufacturers could utilize the bladeless turbine in order to replace thousands of moving parts in a combustion engine and so



easily double the life span of the engine. Jeff Hayes says that in addition to the lowered need of energy for construction of such a car, the Tesla engine would also improve fuel efficiency by the factor three. He explains how the turbine fits the concept of a highly efficient electro-mobile, where the bladeless Tesla turbine drives a high frequency A/C Tesla generator, which again drives an electric motor.

If there were no political obstructions against the marketing of such a system, this technology could be implemented “almost on the spot”, Hayes further explains. But he believes, that the government would not likely support a system that reduces petrol consumption, as a part of the governmental returns is derived via taxes from fossil fuels.

While sometimes Tesla might have had his problems with the patent examiners, an inventor who researches in the fields of free energy is facing much more difficulties nowadays. In the Reagan era for example, the U.S. Patent and Trademark Office was headed by an officer that had switched over from a high rank position at Philips Petroleum.

In 1901, Tesla had patented the receiver for free energy as a device for the utilization of radiant energy. The patent specification names “the sun and other sources of radiant energy, such as cosmic radiation”. The fact that this device is working even during nighttime explains that cosmic radiation is omnipresent. Tesla called the earth in this context as a huge reservoir of negative electric charge and in his fascination for radiant energy he believed that it could be possible to utilize energy by “tapping directly into the basic wheelwork of nature”.

His receiver for free energy comes closest to this concept amongst all his patented inventions. This invention comprised a glossy metallic plate that was transparently laminated. Such a plate was exposed in an elevated position and connected to a condenser. On the other end the condenser was connected through a good grounding (earthing). In this way the condenser is getting charged with energy. If the condenser is further equipped with a switch circuit that allows it to rhythmically discharge, then this energy can be utilized.



Tesla did not only work with electric currents, but also with forms of energy that still seem abstract for our mechanistically shaped comprehension. He was eons ahead in his thinking.

Directly linked to Tesla's studies in the fields of free energy devices and energy transmission are the so called Purple Plates, also known as Tesla Plates, that are in the public domain since the 1970s, and since their introduction, they have been appreciated by tens of thousands of individual users worldwide, who would not want to miss them anymore. Although these plates are not a direct development of Nikola Tesla, they are the legacy of experience obtained by the late Ralph Bergstresser who enjoyed direct and privileged access to Nikola Tesla's laboratory work and got inspired by his ideas.

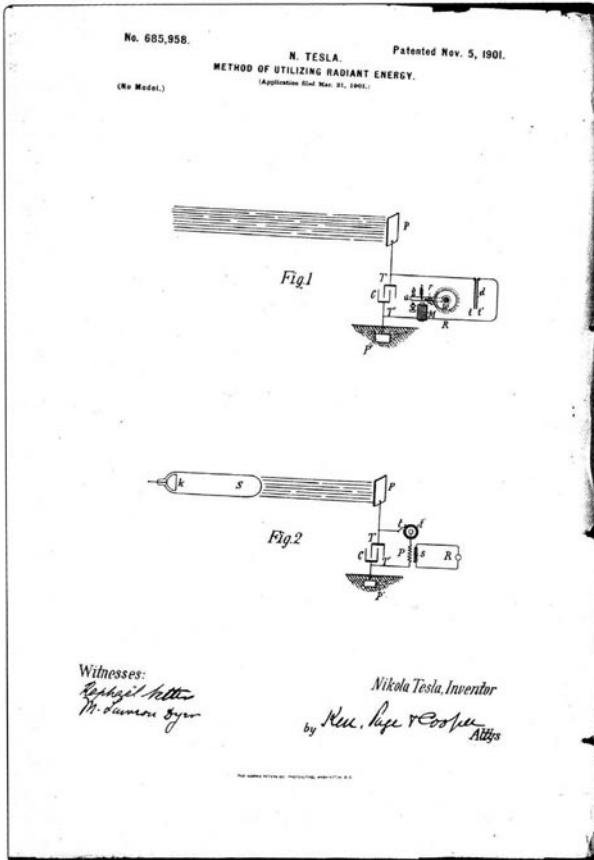

Nikola Tesla's American patent for harvesting radiant energy, dated 1901, from which the idea for the Purple Plates has been derived.



The Tesla Plates are made from aluminum, a material characterized by naturally orderly lattices, which is then forced into a still more regular and homogenous molecular structure by a special technical process. As an effect of this alterations, the lattices start to oscillate at a frequency that resonates with the frequency of the earth's own electromagnetic field that permeates the cavity between the earth's surface and the ionosphere. This field is known as the Schumann Resonance field and has a base frequency of roughly 8 cycles per second (7.83 Hz) with detectable overtones extending upwards into the kilohertz range. This global electromagnetic resonance phenomenon is named after physicist Winfried Otto Schumann who predicted it mathematically in 1952. The Schumann field is considered to be associated with the biofield (Chi or Qi, Prana, Orgon etc.) containing all the essential information and energy necessary for the proper functioning, growth and evolution of any life form. The structure of this biofield is in close correspondence with the molecular structure of living organisms and seems to have a direct impact on brainwave activity



and DNA functions. The human brain actually oscillates at a frequency spectrum that matches the Schumann Resonances. However, the exact mechanisms are very complex and it would lead beyond the purpose of this essay to attempt a trial for a more detailed technical explanation. A variety of research projects are still underway to derive a more precise understanding of all involved principles. From practical observation though it can be concluded that the plates work like transceivers (receiver and transmitter) allowing the communication between the biofield and the site of application. They have the capability to pass life energy on to any organism or substance in their proximity increasing the bioenergetic potential.



Bergstresser who who was an assistant to Nikola Tesla, and who drew upon his lab experience with Tesla to develop the plates described the process as follows:

*"How do these units work? The atomic structure ... of our products has been altered. This process brings these products into resonance or harmony with the basic energy (free energy) of the universe. These devices are like transceivers (receivers and transmitters). They create a field of life force energy around themselves that will penetrate any material substance ... by osmosis.*

*The most important energy in our life ... is our own vital energy. The atomic structure of our products has been altered so that they are in harmony, in tune, or in resonance with the life force vibration. The products create a field of energy around themselves and by 'osmosis', this energy will penetrate any living thing including an individual, plant or animal.*

*With radionic equipment, the life force energy may be measured on an individual. For example, on a scale of say from 0 to 100, the energy reading of a person might be twenty to twenty-five. When the person is handed an energy plate, the reading will instantly increase up to ninety or ninety-five on the scale. This is an indirect method of proving the product. The frequency of this 'life force energy' can not be measured directly by any known device.*

*Many years of research and study were required to bring about these products. A curious mind is required for scientific progress outside of the conventional realms. This all started in India over forty years ago when I was guest of a maharaja. He had an eight month old son that was very sick. I asked if he was going to get a doctor. He said 'no, we have sent a man to obtain some holy water from the Ganges River.' In three days, the man came with one gallon of water. They fed the water to the sick child ... and like magic, the child was healed and back to normal.*

*To me, a miracle is the inability to understand a scientific fact. How could the water cure the child? That was the problem. It was this incident that triggered my curious mind to find the answer and this led me into the*



*present knowledge. My conclusions after many years of research. God is Energy. God is Love, Positive Energy is Love. The 'Life Force Energy' is God."*

There is reason of believe that mono-polarity is obtained within the plates and that the special states and properties achieved therein are transferable to any surrounding media – gaseous, liquid or solid, organic or inorganic. Reported observations include: neutralization of acidific properties of water and other liquids (such as wines), imparting of new properties of gases such as ionisation. The freezing point of liquids is temporarily altered in the proximity to the treated lattices.

The following excerpt is from Linda Goodman's Book

***Star Signs:***

***The Secret Codes of the Universe, Forgotten Rainbows and Forgotten Melodies of Ancient Wisdom***

*(ISBN 0-312-19203-7, a St. Martins book)*

**Note:** *This text represents the personal opinion of said author and does not deal in scientific or medical facts but in subjective experiences!*

We've already learned that each material object and each human being vibrates to an individual frequency of angstrom units (light waves) per second. This is the life force energy responsible for universal harmony and synchronicity . . . the forgotten rainbows and forgotten melodies creating the Oneness of the Universe established by Cleve Backster's Primary Cell Perception discoveries. In India this life force energy is called Prana, but whatever it's called you could not live without it, and at present you're using only a fraction of its power.

Your third dimensional mind can use it to tune into the fourth dimensional cosmic consciousness (your Higher Self) ... allowing you to "see the



light" . . . to become in tune with the harmony of the Universe, for within these colors and chords all magic is conceived, all miracles are born. There are many ways to tune in. Not just one or two. Many.

One of them is an Aquarian Age, Tesla-inspired discovery I call "the purple plates," for want of a better term. These plates have been channeled to Earth from the higher realms, through the mind and brain of a man who knew Nikola Tesla, and has studied his discoveries in depth, but who prefers to remain anonymous, as do many Cancerians of profound insight.

These anodized aluminum plates are created in two sizes, one measuring approximately three inches by five inches and the other measuring approximately eleven inches by eleven inches. Just one of the smaller plates will create mountains of magic, but I find it useful to have both sizes, for various purposes. The plates have been anodized with the color Violet, which is the healing ray of the rainbow spectrum. Their atomic structure has been altered, so that they are in resonance with a high-frequency vibration of the life energy force, in a complex way, connected with the known energy of negative ions. The "purple energy plates" (my own personal name for them) possess a field of energy capable of penetrating any living thing - plant, animal or human.

The life force energy, or Prana, can be measured in several ways. One of them is through radionic equipment. Using this measurement, the energy level of an individual man or woman not yet fully illuminated might register, say, 20 on the scale. When this person is handed a purple plate the reading will instantly increase to 90 or 95. It won't remain at that level, but continual use of the plate will gradually bring the person's energy to 100 permanently. Enlightenment. And higher than 100, since the life force energy cannot be completely measured by any device presently known. And so, the use of this New Age "magic" will eventually raise your frequency rate of angstrom units per second, which is of obvious benefit to your spiritual evolution, as well as your path toward cell regeneration (see Chapter 9).

Precisely how the plates work should not be of as much concern to you



as what they can do for you. There are so many mini-miracles the plates accomplish (some of which you'll discover for yourself) it's difficult to detail them. Here are just a few.

First and foremost, the plates will slowly but very surely raise the vibratory frequency of those who use them, and that's of prime importance. They will reduce the negative vibrations in food, water, other liquids and tobacco. Many people who own them place their food on the larger size plate while it's still in the shopping bag from the market, for about fifteen minutes. Travelers often find that the water in a foreign country makes them ill, but won't if the water is energized on a purple plate for two or three minutes. Cigarettes become milder after being placed on the plate for fifteen minutes or so, and pineapple, for instance, will lose its sour taste and become sweet tasting.

The magic I personally find to be the most helpful involves pain. (Artesians have a low pain threshold!) When a purple plate is placed on a burn or a cut ... or tied with a ribbon or cord on an ache or a pain anywhere in the body, healing is noticeably accelerated, and the pain either greatly lessens, disappears entirely with amazing swiftness, usually within five to ten minutes seldom longer than twenty minutes. This is accomplished by the plates energy in returning the injured cells or tissue to a normal vibrational rate: thus the healing and disappearance of pain is due to the afflicted area being turned to the proper balance.

One of the construction workers employed by the contractor in the modeling of my house in Colorado came to work one day with a "split migraine headache," and was about to take the day off, until I tied a „magic purple plate" (the small size) on his head with a sash from a bathrobe (making him look like Spock when Spock and Kirk prepared to visit the twentieth century in the film Star Trek IV). I asked him to leave it on his head for fifteen minutes. He felt rather foolish, but agreed, and less than five minutes later when I asked him about his headache, he was up on a ladder, pounding nails. He looked down at me, grinned, and said, "It's gone. Completely gone."

"All right, then give me back my purple plate," I said, smiling back him,





pleased as always to observe the never failing magic. He replied quite seriously, "No way are you going to get this back! I'm leaving it on all day and I'm taking it home with me." He was only half serious, of course, but I graciously gave him the plate as a gift, and he was as delighted as if I had given him a magic wand - which, in a way, it is. Anyone who treats a friend with purple energy plate is going to receive a lot of pressure to allow the friend keep it, so it's wise to have several on hand for emergencies. The incident I just related is but one of more than a hundred headaches I've observed cured instantly by the purple plate over the years.

Another time (one of literally thousands of examples) a friend was chopping wood for me, and "threw out his arm." His upper arm was giving him severe pain, and he was on the verge of deciding to have someone drive him into Woodland Park to a doctor. I made him sit clown on the couch, fixed him a cup of hot tea and tied a purple plate on his arm. By the time he had finished the tea (and a slice of cake) the pain had completely disappeared, and five minutes later he was out in the back yard chopping wood again. New Age medicine!

One of the magics I've depended on numerous times is the energy plate's ability to remove the sensation of nausea almost instantly. Any time I feel severe nausea, for whatever reason, I rush to get a purple plate, lie down on the bed on my back and place the plate on my solar plexus. The large size plate usually works more quickly in this instance, but a small one also does the job, taking only a few minutes longer. Using the plate in this way causes all sensations of nausea to disappear within no longer than five minutes, usually within one to two minutes ... and sometimes in thirty seconds. I don't know what I would do without that reliable pain and nausea reliever being always available when I need it in a hurry. My women friends with "morning sickness" from pregnancy treat their purple plates as if they were precious jewels.

Some of my friends sleep with the plate tucked into the pillow case (on the bottom side, not the head side) all night. The energy goes through anything and everything except metal. They awake in the morning with more energy, and feel as if they've had a full eight hours sleep, whether they have or not. A few people are unable to raise their vibratory rate in



this manner because they're so sensitive to the energy, they stay awake all night! In any case, this use of the plates should be limited to one or two nights a week, and when it's important to wake up early the next morning with extra energy for the reason of an important meeting or appointment the next day.

As for raising your vibratory frequency with the plates, some people will feel increased physical energy and less fatigue by tucking one in the pocket of a shirt or blouse for thirty minutes to an hour, twice a day. Every individual is different, and experimenting with the plates will quickly tell each person the most effective way to use them relative to his or her own personal response.

In addition to removing nearly all kinds of pain almost instantly, and all the other minor miracles manifested, there is one particular use of the purple energy plates I've found to be truly amazing, nearly unbelievable, yet observably and infallibly true. There's no way to completely convince you of the validity of this, I suppose, unless you try it yourself.

We've already learned that each person vibrates to an individual frequency of light waves, a metaphysical truth or fact that is the foundation of a vast amount of unguessed and unsuspected "magic". Natives in civilized jungles often refuse to allow missionaries and other visitors to take their pictures with a camera, for reasons founded in such "uncivilized" (uncluttered by civilization's mental smog) minds, and seeded by the more active sixth sense, and Third Eye possessed by these Earthlings. They claim that the one who photographs them, in some mysterious way, is "robbing them of a piece of their souls."

This isn't true. However, the photographer is "stealing" their frequency rate, and it's not mysterious to anyone who understands the individual vibratory frequency we've discussed. Somehow, through the process of photography, the individual frequency of the person who is photographed is impressed upon both the positive and negative print. Therefore, this particular purple plate magic only works when the "negative" of the positive print used has not been destroyed, and is known to exist somewhere, whether in the home, or even in the files of the photographer who took the original picture - or when using a Polaroid print, containing both



the positive and negative on the picture itself, back to back.

Let's say a child, a mate, or loved one or a friend (perhaps an employer or neighbor or co-worker) is behaving in a most negative and exasperating manner, as we all do, from time to time, human nature being what it is. You can literally turn that person around, changing his or her attitude from negative to positive - not permanently, but until the next time - by using your purple energy plate in the following way. (But don't tell the person what you are doing.)

Place either a Polaroid photo or a positive print of a photo, the negative of which you know to be in existence and not destroyed - on a small-size purple plate, face down. Leave it there for no longer than an hour. Usually within approximately fifteen to twenty minutes that person's attitude will undergo a startling change, will be completely transformed from "nasty," stubborn, selfish, angry, annoyed or unsympathetic - to apologetic, cheerful, unselfish, sympathetic and pleasant. You really need to experience it to comprehend the sheer wonder of it. Within minutes, the person will contact you by phone or in person, depending on where and how the "disagreement" took place - (or you may initiate the contact yourself) - and will demonstrate a complete change of attitude, often apologizing for the former negative behavior or speech. The first few times it happens you'll be truly stunned ... almost awed by this kind of energy power. Or you may choose to manifest this magic before you communicate with a certain person to ensure that the phone call or meeting is harmonious. Remember never to tell the person what you're doing. The person's mind is then capable of blocking or negating the positive energy infusion.

This kind of energizing with the purple plate should never be attempted for a trivial reason - only when it's genuinely important to change the vibrations between yourself and the other person. And it must not be thought of as some sort of "black magic" to force people to change their own free will decisions, because it will not do that. It's white magic, capable only of temporarily, for a period of time, changing a person's vibratory rate from negative to positive. In other words, if someone has refused to do what you want them to do, this magic may cause a change of heart or mind, only if the individual person wishes to change his or her heart or mind, and is consciously unaware of such a desire. Otherwise,



this process will not cause a change of heart or mind, but it will have the happy result of creating a new level of understanding between you, a sort of truce or peace, causing both of you to be able to handle your conflicting desires, and work out your misunderstandings in a friendly manner, without rancor or ill will.

Here is only one of many examples from my personal experience. A friend of mine who lives in Colorado Springs visited me one day in Cripple Creek, in tears. Her husband, whom she loved deeply, had become an alcoholic. She'd tried everything, but nothing would convince him to stop drinking, although he was, basically, a "religious man," with a kind heart, who admitted that he wanted to stop drinking but just couldn't. I asked my friend if she would lend me a picture of him for a few days.

She looked surprised, but gave me a Polaroid she carried with her in her pocketbook. Then she asked me, with understandable curiosity, what I intended to do with her husband's picture. Knowing that she wasn't yet at a stage of enlightenment to comprehend the powerful harmony frequencies of the Universe, and feeling that her disbelief might short-circuit what I planned, my response was cryptic. I just smiled, and said, "Oh, I'm just going to try some 'white witch' magic."

She left, and that evening I placed her husband's picture on one of my small-size purple plates, leaving it there for the full hour. Never having used the photograph process in this way before, I wasn't sure what might - or might not - happen.

The next morning my friend telephoned me from the restaurant where she worked, in a combined state of happiness and bewilderment. "You can't guess what just happened about an hour ago!" she exclaimed. "Jim (not his real name) stopped in on his lunch hour, and told me he's decided to stop drinking, 'cold turkey,' and he's going to start going to church every Sunday! I could tell he really meant it. He's never been that serious about it before. What did you do to make that happen?"

I told her I was very happy to hear the news, but not to be concerned about the "why" of it - just wait and see how serious he was. Two months



later, she visited me again in Cripple Creek. 'Jim' had been making her go to church with him every Sunday, and he hadn't had a drop to drink. A year later, he was still sober. At this point, I let her believe I had "prayed," using his picture, and gave her back the photograph. Two years after his period of being sober he began drinking again, Then I told my friend the purple plate story, and was rewarded by hearing her express absolute faith in the magic with no skepticism.

Although her husband had by then left to go to another state, and they were legally separated, she asked me for a purple plate, and I gave her one, warning her that no prediction could be made, as with "ordinary" use of it, when it came to something like alcoholism, regarding the length of time it would take for the magic to manifest. Instead of the usual 15 to 20 minutes or so, it could take much longer treatment, once a day or several times a week. She understood. That was last year. A week ago she called me in California to tell me that 'JW' had come back home, and was now permanently cured. He had entered a cure center in another state, and hadn't wanted to return until he knew he was free of the desire to drink. They're as happy as two bugs in a rug, as my Irish elf-mother wed to say. Naturally, I can't promise that the purple plate will always cure alcoholism, but it certainly can't hurt ... and who knows? That's what experimentation is for.

The reason for not leaving a photo on the plate for longer than one hour at a time (and preferably no more often than once or twice a week) is because some people are extremely sensitive to its energy, and too much 'exposure' can cause the person being so "treated" to exhibit nervousness or hypertension. If anyone uses the photo experiment for such an evil purpose deliberately, it will not cause such a reaction, because the law of the Universe regarding the life force energy will absolutely block such a result, boomeranging the tenseness back upon the user. This is an unbreakable law of magic when one tries to use such a sacred life force for evil. The only time to be concerned about overexposure is when the motive has been to be of benefit to someone, and then the tension will be felt briefly, because the overexposure was not intentional. Otherwise, the user will be mighty sorry for having attempted to cause harm to another. The sensitivity of some people to these energies has



been demonstrated by what occurs when the plates are brought into the vicinity of mentally disturbed patients in institutions. They react in various ways, but always intensely; therefore, it's advisable to use the photos of any severely mentally disturbed people you'd like to help for no longer than a half hour each time.

While you're pondering what I realize you may believe to be the bizarre nature of the energy of the purple plates, especially as used with photographs, you might keep in mind that scientists have been for several years successfully experimenting with eradicating insects by irradiating a photograph of the diseased fields. Orthodox scientists, that is (I knew that would make some of you feel better!) By the way, it doesn't matter whether the photograph you expose to these life force energies is one taken recently - yesterday - or when the photographed subject was a child or an infant. The individual vibratory frequency doesn't change.

The only pain or discomfort the purple energy force field has not relieved, in my personal observation for more than ten years, is the pain caused by a twisted muscle, a slipped disc, or misplaced vertebra. All other pain is swiftly either greatly relieved or completely banished. I almost forgot a special message to plant lovers. Water your plants with water treated on a plate, and notice the difference in their growth. Also, place a purple plate under fresh flowers from a florist, and they'll last nearly twice as long before wilting. Regarding plants, there's another bit of magic that's been developed by the same Nikola Tesla-inspired researcher, along with several other energy innovations.

No medical healing claims are made for the purple plate energies. They're not intended in any sense to replace the proper treatment of serious health problems by a professional holistic medical doctor, and I'm sure my readers have the common sense to realize, for example, that complaints such as chest pains need immediate medical attention. But as for the other magics I've described here, you'll discover for yourself how effective the purple plates can be, and you'll never be without one after you've seen what they will do .... far more, I promise you, than the over-the-counter medications that receive such high-profile advertising in all media, to which the medical profession doesn't object.



One final incident of the purple plate life force energies (you'll discover lots of uses on your own): A teacher friend of mine in Colorado has found the perfect remedy when one of her grade-school students is being naughty and disrupting the class. In her schoolroom is a chair with a pillow on the seat. No one is allowed to touch the pillow or go near the chair. It's called The Magic Good Pillow. Any student who is behaving badly is told to "sit on the Good Pillow" for fifteen minutes. When the child returns to its seat he (or she) has turned (at least temporarily!) into a perfect little angel. Of course one of the large plates is beneath the pillow. My teacher friend has discovered her own personal way of creating purple magic.

The plates have been in use by many people for more than fifteen years - (written by 1988) I've had my own for more than ten years - and they still function as effectively after that length of time. Once the structure of the atoms of the aluminum have been altered, they will remain in that condition ... probably indefinitely. The plates are not "charged"; they are simply altered to vibrate with life force energy of the Universe - what Nikola Tesla called "free energy."

Translating my personal choice of "purple" plates to describe these energies (possibly because my favorite fairy tale as a child was about a "purple elf named Leser") .... into the true color of the plates, which is the rainbow spectrum musical "tone" of violet, it represents the seventh ray and the "violet flame" of the Avatar-Adept, the Conte de St. Germain. In metaphysics, violet is the healing ray of the spectrum.

### **Linda Goodman**

***Note:** This text represents the personal opinion of said author and does not deal in scientific or medical facts but in subjective experiences!*



The Nikola Tesla Institute in Zurich, Switzerland has further investigated and enhanced the process and is now offering Tesla Plates and Discs for a variety of applications. A special black crystalium plate has been devised to counteract the dramatically increasing electromagnetic load present in our modern environment interfering with our life force. These plates and chips are a valuable aid in relieving systemic stress caused by computers, switch boxes, mobile phones, cordless phones, microwave ovens etc. that all emit high amounts of electromagnetic frequency and electromagnetic radiation (EMF/EMR). Such electromagnetic fields tend to overpower and interfere with the subtle bioenergetic processes within a living organism, thus impairing its proper functioning and posing it at risk of systemic failure.

Apart from the traditional purple color plates there are now plates in 6 additional specific colors obtainable. Together with the purple color they are representing the seven colors of the rainbow and each color is corresponding to a certain frequency as prevalent in the system of the seven main chakras of the human organism. These plates are therefore combining the properties of the original purple plate with the frequency of a particular color and are mainly used in color therapy or as a decorative variation of the original purple plates – the strength of the plates remains unchanged whether its color is purple or any one of the others available.

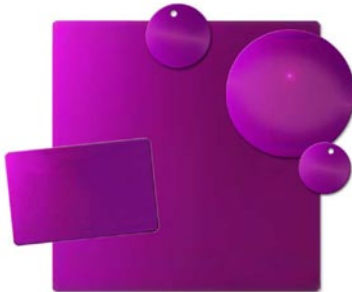

The Plates also come in various sizes, as the potency of the plate is directly related to its size. As different individuals react in different ways, the size of the plate can so easily be adjusted to the personal sensitivity. The larger round disks further make very attractive coasters, which can be used under the drinking glass thus enhancing any beverage with induced life force and improved taste.

While the purple plates are considered standard choice, all plates can be used for almost any application. So you can simply pick your favorite color or select a color according to its properties for a certain purpose. On the following page you will find a short overview of the characteristics of the available colors.





**RED**

***Muladhara = root chakra***

adrenal glands; general life functions, controls body fluids, regulation of temperature. Life force, energy, self-actualization, self confidence, decision making, success.



**ORANGE**

***Svadhithana = sacral chakra***

Orange: gonadal; aids weakness of circulation, heart problems, fatigue, lack of energy. Enthusiasm, self assurance, sociability, joy, friendship, constructiveness, compassion.



**YELLOW**

***Manipura = solar plexus chakra***

pancreas; brings mental alertness, stimulates the nervous system, facilitates excretion. Cheerfulness, generosity, optimism. phantasy, striving for success, logical thinking, expression of self.



**GREEN**

***Anahata = heart chakra***

thymus; calmes nerves and heart, benignly influences the aging process. Compassion, love, equilibrium, well-being, harmony, stability, reliability, adaptability, growth, abundance, love, nature, vegetation, immune system.



**BLUE**

***Vishuddha = throat chakra***

thyroid; helps against high blood pressure, infections, migraine, insomnia and during menopause. Communication, patience, honesty, confidence, peace, calm, meditation, truth, faithfulness.



**INDIGO**

***Ajna = third eye chakra***

pituitary gland; mergence of the other chakra colours, adjusts the flow of life, growth, metabolism, harmonizes left and right brain. Communication, patience, imagination, wisdom, inspiration, spiritual power, raising consciousness.



**PURPLE (VIOLET)**

***Sahasrara = crown chakra***

pineal gland; joining of contrarian energies, consciousness, enlightenment, general healing on all levels. Spiritual energy, joining of matter and spirit, transformation of soul and spirit.



## Some possible applications and results

*Please note that the following examples of application are based on reports from customers and are not to be taken as a general recommendation or guarantee for the treatment of a particular illness. The plates are not a substitute for proper medical treatment and can only be used complementary with any necessary medication or medical therapy.*

The examples are individual experiences and therefore cannot be considered as a general recommendation. You might experience different, similar or no results at all with comparable symptoms. These reports only serve the purpose of inspiring you to freely experiment and make your own playful experiences with the Swiss Tesla Energy Plates. Be a discoverer yourself - just like Nikola Tesla.

The effect of the Swiss Tesla Energy Plates is based on an increased supply of vital energy or life force which supports the self healing mechanism of the body/organism. The plates don't cure by themselves.

Do not attempt to neglect your subscription medication or a healthy life regimen as the plates hardly reward improvidence! The plates are not to be associated with magic and miracles (although you may expect a miracle...). They do have certain properties based on verifiable or explainable physical and energetic principles.

Improved personal energy resources can contribute to personal or spiritual development, but typically they are the result of - and not a substitute for - a self responsible conduct of life and proper medical attention to symptomatic manifestations.

### **General guidelines for application:**

it is not necessary to have a direct contact with the plate's surface, as every plate generates a field. You can carry the plate in the pocket, purse or wallet.

At night you can place a small plate under your pillow or a large plate can be placed under a mattress.

Drink plenty of energized water. Simply place a jug of water on a plate and drink this water throughout the day. Use only clean bottled, filtered or boiled water!

It is recommended to discharge and refresh the plates every 2 - 3 weeks for a few minutes under running water.



### Experiences from users:

**Accupuncture:** pain relief and energizing with discs attached to accupuncture points or joints instead of using needles showed good results in many cases.

**Ageing - old age:** application of plate on the head directly over the epiphysis showed significant improvement in depression, debility and even Alzheimers disease. Observed improvement of mood, sleeping patterns and memory.

**Agressivity:** placing a photo of an aggressive person on the plate rendered the person peaceful after 3rd day of application. (refer to Linda Goodmans chapter)

**Alcoholism:** Reports from cured alcoholics after keeping the plate with them.

**Allergies - Fruit:** leaving fruit overnight on the plate showed improvements after 2 days and after 1 week fruit could be eaten without symptoms.

**Allergies - Metals:** (e.g. nickel): Jewellery placed on plates prior to wearing greatly reduced or stopped allergical reactions.

**Arm pain after twisting:** a plate has been strapped onto the upper arm. shortly after the pain was gone and arm was fully functional.

**Arthritis:** With arthritis of the fingers great relieve has been experienced.

**Asthma:** Plate placed on chest during attack relieved the symptoms.

**Burns:** Plate applied on wound. Pain subsided immediately, no blister formed.

**Collics:** five month old baby would not make collics and slept well, when plate was placed under mattress.

**Cuts:** application on cut showed good results in closing the wound quickly.

**Depression:** observed many cases of improved energy levels while using plate.

**Detoxify foods:** Place full bag after shopping on large plate for 15 minutes to bust bad vibes, neutralize toxins and get energetic foods.

**Detoxify linens:** Place plate on bedding, linen and clothes to neutralize toxic residues from manufacture and cleaning processes.



**Earpain:** Plate applied over night on ear. The next day pain ceased.

**Eczema:** applying plate on affected area showed improvement within hours with liquids being drawn out. After 6 days it was gone (plate under pillow at night).

**Elektro-smog:** Disturbances caused by electromagnetic fields from power lines and appliances were greatly reduced placing the plates at relevant locations.

**Energy - increase:** carry plate/disc during 1 - 2 hours or if convenient all day on or near body. discontinue if tiredness is felt. give body time to adjust.

**Fear.** dentist, exams, interviews - many positive experiences when carrying along a plate.

**Fissures on Fingers:** After unavailing treatment with cortison for several years, healing was achieved after application of plate.

**Ganglion:** Plate fixed over night. 3 weeks later deformation was gone.

**Knee - old standing pain:** After 6 years of pain, plate was applied. Swelling and pain decreased after 15 minutes and knee could be bent again.

**Headaches:** Keep plate alternatively on forehead and temples. give one hour for headaches to subside.

**Kidney pain:** Application of plate directly on kidney area day and night. Plate turned warm. After application pain was getting bearable.

**Migraine:** a case of 25 years persistent migraine resolved, when patient brought plate near body (aura 20 - 30 cm).

**Mosquito bite:** allergic reactions to mosquito bites (swelling, itching) vanished after one hour of placing plate on affected area.

**Muscle - strain:** pain from pulled muscles subsided completely after application of the plate for 2 days.

**Nausea:** Plate applied to solar plexus made nausea cease after 15 mins.

**Neurodermitis:** Itching disappeared upon application of plate. Creaming with cream first placed on plate improved healing.



**Pets:** 11 years old german shepherd dog with hip trouble got to drink energized water and plate applied once for 15 minutes. After one week dog showed no signs of pain but good vitality, shining fur and lustrous eyes.

**Plants - growth:** after plate was plugged into pot for 3 1/2 months, plant showed double the growth compared to 'untreated' plant. An orchid treated in the same way started blossoming the first time after 7 years.

**Psoriasis:** started healing immediately after application of plate.

**School problems:** Bad marks due to difficulty in concentration improved after placing plate under pillow before and wearing it in the pocket during exams by a 15 years old student.

**Sciatica:** Effects of allopathic medication was improved when in addition to medicine plate was applied during daytime and slept on plate at night.

**Sleeplessness:** a plate placed under pillow induced deep and refreshing sleep.

**Smoking - attempt to stop:** Cigarettes placed on plate for 3 mins. prior to smoking rendered them tasteless and craving disappeared.

**Spraining:** back to normal within 3 days of applying a plate on site.

**Stomach ache:** Plate applied on soring spot, pain eased up shortly after.

**Toothpain:** Plate applied for 3 consecutive nights. Pain vanished. Many case reports of subsiding toothpain within the hour or a few minutes.

**Disclaimer.** We advise you, that the properties of these products can not be tested in a "regular" scientific way by using standard laboratory methods. These products are neither approved by the FDA nor any other governmental agency within or outside the U.S.A. nor do they replace medical therapy or supervision. Unit Not Intended For Medical Purposes - The US Food & Drug Administration (FDA) prohibits manufacturers of instruments from making health or therapeutic claims for effects relating to the physical or mental illness being currently treated by members of the medical profession and/or other licensed practitioners unless said instruments have been registered by the FDA.



*All information included in this booklet is meant for educational purpose only. No product or application described is intended to treat or cure any illness. No information, product or application substitutes for a self responsible lifestyle and proper health regimen.*

*The fact that there are tens of thousands of satisfied users of Tesla Energy Plates worldwide does not automatically allow the manufacturer or reseller of the product to state any health claims. The governmental health institutions and the applicable laws and regulations are clearly prohibiting such statements.*

*However, if you make a positive experience by using our product, you are free to share your experience with the rest of the world. There are many more amazing testimonies from satisfied customers available on our website.*

For further information on Nikola Tesla and Swiss Tesla Energy Plates please visit our website under **[www.swisstesla.com](http://www.swisstesla.com)**.

### ***A final word from the author***

*This book has been compiled from various sources and all information given herein has been researched with all care. However, it is the nature of historical events to diffuse over time and therefore different sources sometimes allow for different interpretation of such events. In case you detect any inaccuracy or lack of vital information which you wish to share with the author, please contact us through the contact section of our website [www.swisstesla.com](http://www.swisstesla.com).*

*It was our aim to write a short and comprehensive essay about the life and work of Nikola Tesla and to further explain our products to the layman reader, rather than to deviate into great historical and technical depths. You will find a lot more information in the links and literature section of our website and we encourage you to review this materials.*

*We wish you will derive some further insights from these studies. When we first came across this information, we found it quite surprising in the face of present conditions and state of our planet, but also enlightening to realize that our world REALLY DOES HAVE the potential to look very different, if more and more people get attuned to the simple truths.*

*As the great Nikola Tesla would say: Energy can be FREE for the benefit of everyone. Yes, and it can be clean, too. Please remember this when next time you fill your tank or pay your electricity bill...– and please feel FREE to send this ebook to a friend – after all it's FREE!*