

The Fuelless ENGINE

Free Energy Technology is now in your hands! If you decide to build this motor / engine, build it for your own use only and keep it from family, friends and the News Media. The Fuelless Engine is a spin off of the Ed Grey Motor as well as a combination of our own designs as well as The Newman design. This motor is like no other electric motor in the world. You can run this motor on 300 to 1,000 volts dc, (using a special coil design as well as the designs included in these plans.)

Please Keep all of this information to yourself! When Free Energy Electric Motors are allowed to be manufactured here in the USA we will show you how to get even more free energy from your motor than ever thought possible! But for security and Patent reasons we can not reveal to you all our secretes But we will keep your on file and let you know of any updates we can safely share.

You can make the outer shell case out of just about anything you want to. But we suggest you use steel tubing or aluminum tubing for anything over 100 hp. Anything below that you can use 1/2" plywood box. What most of our customers use is green 1/4" x 14" diameter PVC sewer pipe.

Creative Science & Research
PO BOX 557
New Albany, IN. 47151
www.fuellesspower.com

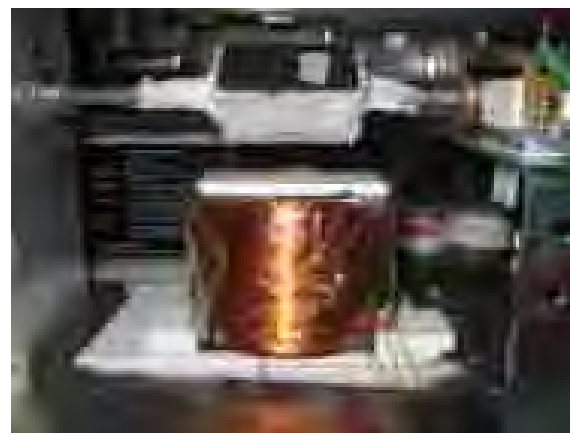
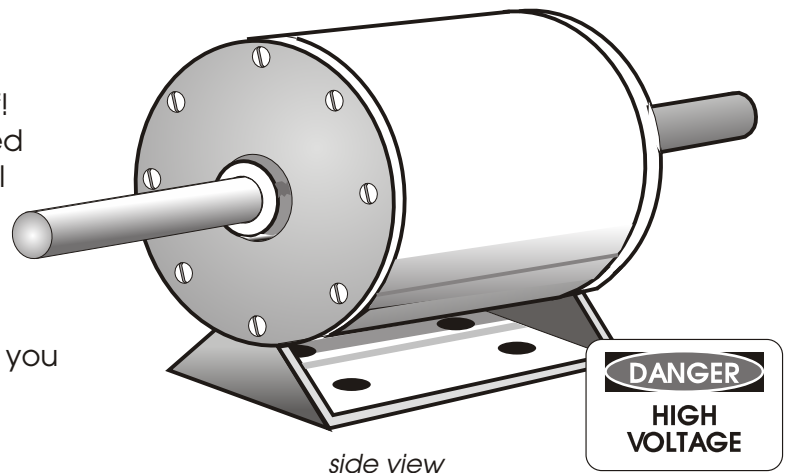

4-Pole design. All magnets in the 12:00 and 6:00 positions fire at the same time, pushing apart with great force, to cause the Rotor shaft to turn. This motor can be ran in forward or reverse. This is our first prototype model and can be scaled up or down to any desired Hp you like. Of course one can improve on this design, see our #362- RC plans. We made it simple in design for those who are not educated in the art of Electric Motor building and repair. It is a good idea to study a simple Science fair DC Motor etc... To get a basic understanding of DC Motor designs. A good source is your local Library.

All HV electromagnets are wired North Pole to North Pole. They can also be wired and timed to attract each other if you wish to make an attraction motor.

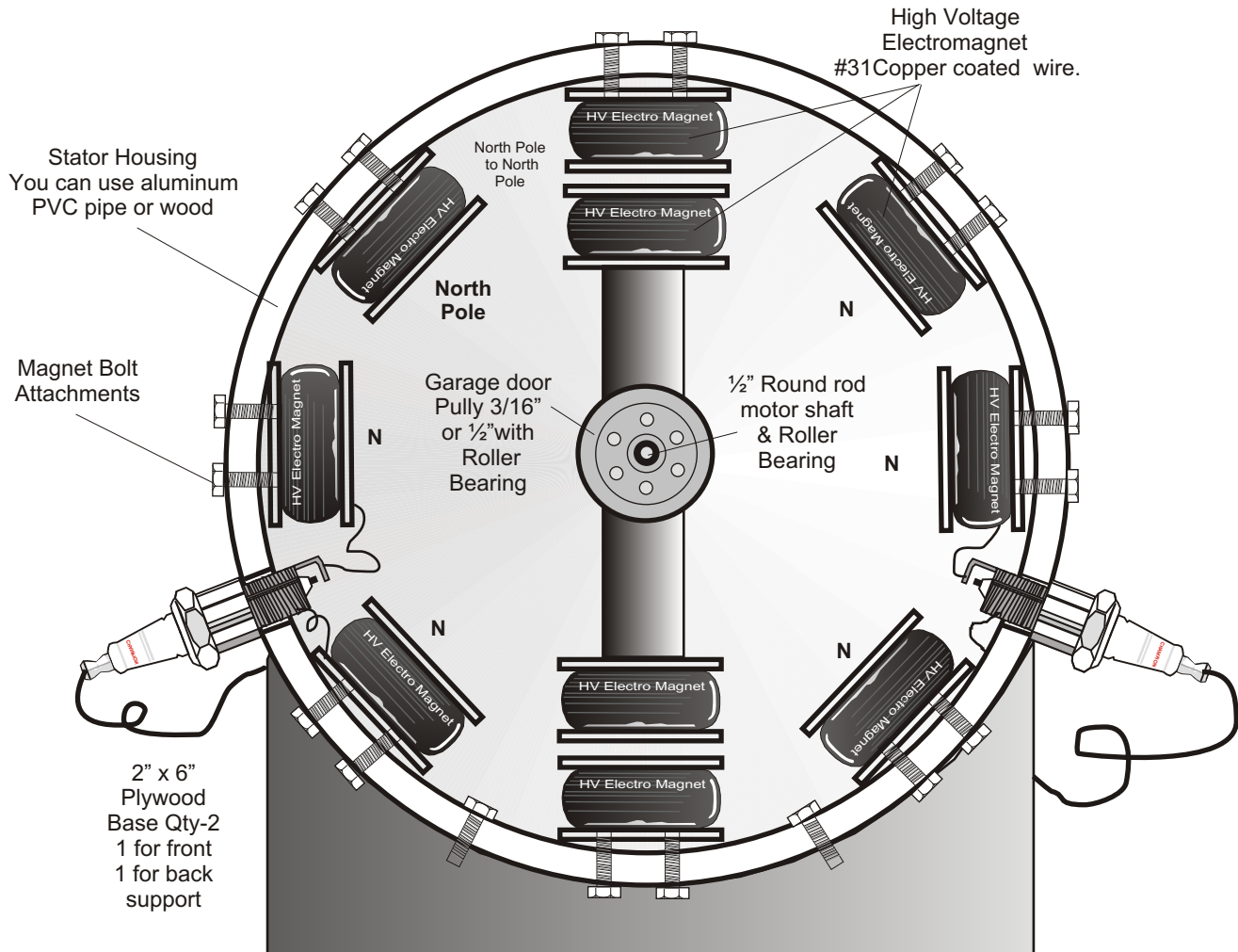

You will be using 2 - 4 spark plugs as high voltage switches, To send a DC high voltage to 4 coils at a time. You can design this engine any way you want or any shape you want, just as long as you keep to the main working principle. The motor can be as deep as you want to design it. If make the magnets or your air core magnets about 4 to 6" long, it will be much easier to turn on a slow rpm drill press. I find that wrapping the coil with #31 wire at about 150 rpms works best, 250 rpms is a little fast but can be done. We strongly suggest you first build a one Hp or less DC fuelless motor first.

How It Works:



362

Ignition Stages (timing)

12:00 POSITION

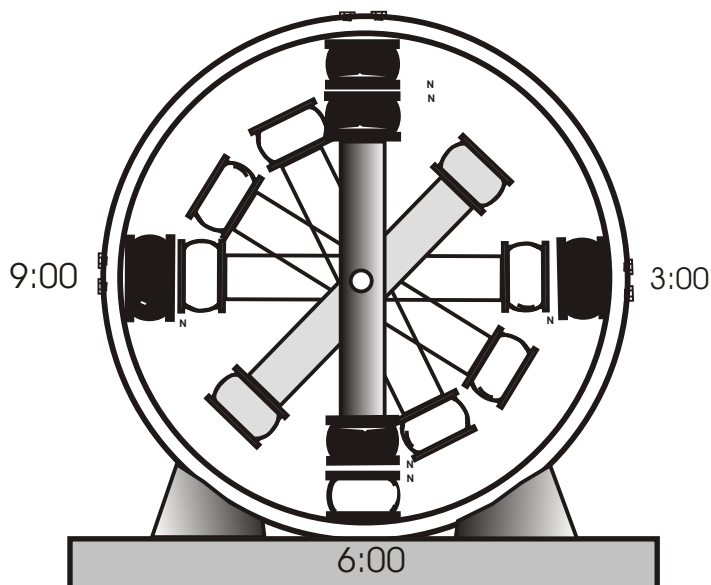

The Fuel less Engine uses 300 to 1,000 vdc rated in the milliamps. You can use a 115 vac x 500 watt inverter connected to a 12 volt dc battery, and then step up the voltage to 300 vdc or up to 1,000 vdc using a high voltage transformer or our voltage multiplier plans which uses capacitors and diodes to step up the incoming ac current.

The HV Electromagnets: Use # 27 copper coated wire. You may already have a supplier in your area for wire that they sell in spools. Check your yellow pages phone book for Electric Motor repair shops, they may sell you some or they can tell you where to buy it in your area, if you still can't find it, you can buy it on the internet, there are tons of wire companies on the net. Turn your #27 wire around an air core bobbin or a soft iron core. The more turns the better. If you do not know how to build these type of HV Electromagnets, we do sell the plans or you could try your local Library.

Basically this is a large DC Motor Generator that puts out free energy from the coils and caps. It works as so: A 1,000 vdc repulsive explosion takes place at the 12:00 and 6:00 positions, the rotor arm is then forced to the 9:00 and 3:00 positions. The 1,000 volts is switched on and off and is controlled by our easy to build homemade copper pipe commutator. When timing is adjusted just right, the inner rotor arm and shaft will spin very fast! This is much more than just an electric motor, this motor outputs free energy just as well as Solar Cells can do.

The horse power of this motor is determined by the capacitance of your capacitors, your spark plug gap, how many Electromagnets and capacitor banks you use, and the size of your magnets



THE ELECTRICAL SYSTEM

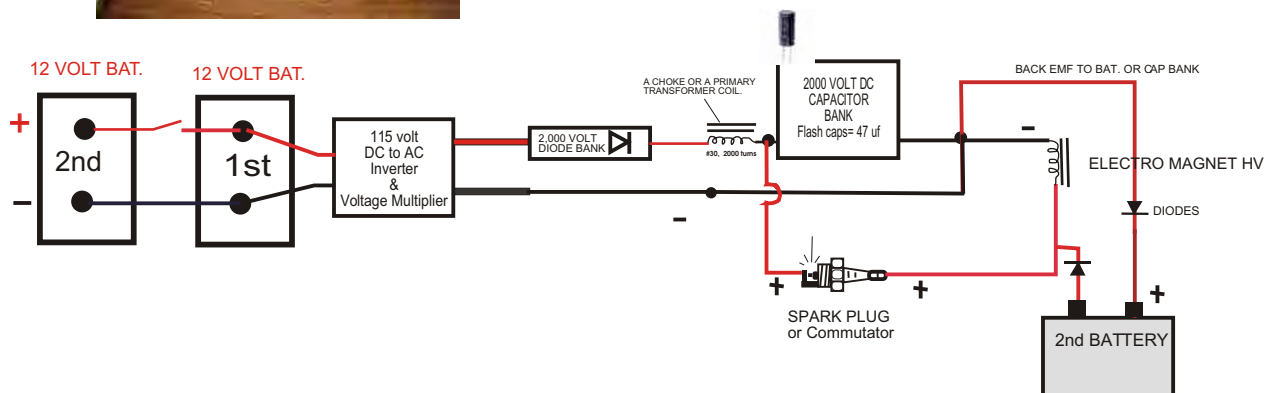

PLEASE READ

Thank you for purchasing these plans! You will be glad you did, If you don't get it at first keep studying it really very easy to do. if your not familiar with any of the subjects in these plans please go to your library or Radio Shack and get a beginners book on electronics, electricity, electric motors magnets etc.... We have sold thousands of these plans and many of our customers have built this engine/motor. This engine/motor/free energy generator does work! If you need technical help please contact us by E-mail only, we will try our best to get back to you and help you as quick as we can.

To Start: An Automobile engine can be converted into a fuel-less engine for free energy, but it should not be done! You will still have some of the same troubles a gas engine has. Such as wear and tear on all mechanical moving parts, oil rings, gaskets, pistons, etc... *too many to name!*

To do it you will need to remove the lifters and head assembly, and redesign the head. it will take two high voltage magnets per piston one attaches directly to piston via a metal angled extension and one magnet positioned on top of that one, north and north poles of magnets facing each other. Then you must hook up the capacitor banks and use the distributor timing for each piston to ignite each piston. The magnets repulse each other taking place of the explosion which takes place in a internal combustion engine. Just like any car engine you will eventually need to have it rebuilt or repaired.

But The Fuel less Engine (motor) will never die! You don't need a cooling system, or oil system. The only parts you will need to replace are the spark plugs *or commutators if you decide to use a commutator system*, spark plug wires and the 2 ball bearings that the shaft rides on. We estimate replacement time every 25 to 30 years. If you build your magnets right they will never break down.

This is no common ordinary electric engine / motor, there is nothing else like it that I know of in the entire world. **The output is free energy which is used to help rerun the motor by recharging the batteries. every HV Electromagnet creates it own energy after power is taken off of it. This electrical phenomenon is called Back E.M.F. , and another type of energy I can not tell you about, But for your knowledge is not needed. This free energy is converted back to the batteries to recharge them.**

WARNING! When working with high voltage keep out of the reach of children and adults who do not understand high voltage rules. Be careful and always wear rubber gloves when working with high voltages. High voltage can kill you. Please notice we are not responsible for anything in these plans, you build at your own risk!

WARNING PLEASE READ!

These plans are for your eyes only! This invention has been suppressed by very powerful people, persons and companies that I can not reveal to you. This invention holds US Patents and these plans are protected. Copyrighted. Let me put it this way, No free energy device at this present time, 2003, can be manufactured or sold anywhere in the world. Believe me we have already tried several times and it is not worth it. But as a back yard researcher you can build discover, research and build any free energy device you want just as long as you keep it **TOP SECRET!** You can build this engine and any other free energy device we sell the plans to for your own personal use only! It would be very wise and safer for you and your family to keep it under lock and key, A good idea is to build yourself a secure Generator room that is well kept under lock and key as well as an alarm system.

Again all of our plans and videos we sell are protected! If we catch anyone reselling them or giving them away copies thereof, we will take legal action against you and anyone else involved.

You can also never show a working Free Energy device such as this one, to anyone in the news media! *I have already tried that anyway, I just caused myself more heartache and trouble. I could go on and on but there is so much I can not tell anyone! My lab and my home have been broken into many times, My phone constantly bugged! My life threatened! I have been researching free energy for over 10 years and I know from experience what I am talking about!*

HOW IT WORKS; THE FUEL-LESS ENGINE puts out far more than it takes to run it! It is considered a Free Energy Perpetual motion machine. It uses high voltage AC at 60 kHz (300 to 1,000 volts) in the milliamps. The high voltage is then converted into DC (direct current) through the use of diodes which are rated at twice the voltage of the input voltage. Then the HV dc is directed to a HV CAPACITOR BANK, See page 1.

Without the invention of the capacitor this engine would not be possible, High voltage in the milliamps can do nothing to a HV electromagnet with out the capacitors. The capacitors quickly store the electrons and so produce a great output of *free* amperage... There is something else that we found that happens that we can not explain,.. something extra is produced by the high voltage that causes this engine to work. ?

So then the electrolytic capacitor bank is now fully charged and the spark plug gap is set to fire at 1,000 volts, It then ignites and a complete circuit is made to the magnets which are facing one another north pole to north pole, An explosive amount of magnetic power then takes place and both magnets repel one another, You can use that power to do work, to power a generator to keep up the batteries and to supply power to your entire home..

You know the first time I tried this I was skeptical, I started out using just two electro magnets that I made *myself*, We placed them on the table and I held down the top magnet just in case it did work. *I didn't want my magnet to get damaged.* So with all I could, I held *and* pressed down on the magnet with one hand and connected the + wire lead to the 12 volt battery, then **POW!** It ignited and almost broke my arm *off*, and I still couldn't keep the magnet from flying thru the air. That's an experiment that I will never forget.

It is impossible to get this much power from a low milliamp source using any other electrical DC store bought motor. **But our motor will do it!**

NOTE: The more voltage you use the more power your engine (Motor) will have, as well as rpms. But anything over 1,600 volts will have to be *well* insulated. Your *soft iron cores of your* electro magnets will have to be dipped in paint and allowed to drip dry for 3 days. Or you can simply buy a 10 LB roll of #30 or so double or triple coated copper wire.... also buy the square type you will get more power.... and be sure to wrap wire as tight as you can, side by side as close as you can...

WARNING HIGH VOLTAGE CAN KILL YOU: DO NOT ATTEMPT TO WORK WITH HIGH VOLTAGE IF YOU ARE NOT A TRAINED PROFESSIONAL. ALWAYS WEAR RUBBER GLOVES AND SHOES, RESPECT HIGH VOLTAGE, DON'T ASSUME JUST BECAUSE IT'S YOUR PROJECT IT'S O.K..

ALWAYS DISCHARGE ALL CAPACITORS BEFORE WORKING AROUND OR ON THEM, EVEN IF THE AC 10 MILLIAMPS MIGHT NOT KILL, IT WILL ONCE THEY HAVE ENTERED INTO A CAPACITOR. WE ARE NOT RESPONSIBLE FOR ANYTHING IN THESE PLANS OR WHAT YOU DO WITH THEM.

YOU BUILD AND EXPERIMENT AT YOUR OWN RISK. SO PLEASE BE CAREFUL

HOW IT WORKS CONT... The center Rotor, Rotates with in the Stator Housing as so: after you turn it on and each capacitor bank powers up to it's firing spark potential then all you need to do is start it by spinning the shaft by hand or starter motor and lets say when you start it's in the 12:00 position it then ignites pushing it to the 9:00 position and the brush timing contacts hit and ignites all 4 magnets again pushing it to the 6:00 position and so on. Of course this all happens so fast and with so much power that you can't see it. To give you an idea about what is happening flip a bicycle on its back and spin the front tire as fast as you can repeatedly with as much power as you can. You see a little of what happens inside this engine but with 100 times more power made by the repulsion of the magnets , the weight of the magnets and rotor and the inertia. Note: the rotor can be made with just one magnet and a counter balance, it will work just fine but with less horse power. The best motor to build is the 1 hp type, which we have included in these plans. For more horse power simply scale it up. Using air core electro magnets are by far the best way to go. The finer the wire you use and the more turns of wire, the more free energy output you will have, but motor input voltage must go up. Using the fine wire will cause the motor to run with very little amperage at all, and then the Free Energy back EMF can then be used to replenish the 12 volt battery or batteries. The finer the wire the harder it is to turn. Hair thin wire breaks very easy.

PARTS LIST

- 1- QTY 3,500 TO 5,000 VOLT dc to ac INVERTER 30KHZ TO 60 KHZ
YOU CAN BUILD YOUR OWN OR WE SELL THEM ON PAGE 4
OF OUR CATALOG.
- 4-QTY SPARK PLUGS TYPE CHAMPION COPPER PLUS 855 DJ7Y
OR ANYTHING CLOSE
- 2- QTY 12 VOLT CAR BATTERIES OR 4 -QTY 6 VOLT BATTERIES.
- 6-QTY 5,000 VOLT DC ELECTRO MAGNETS

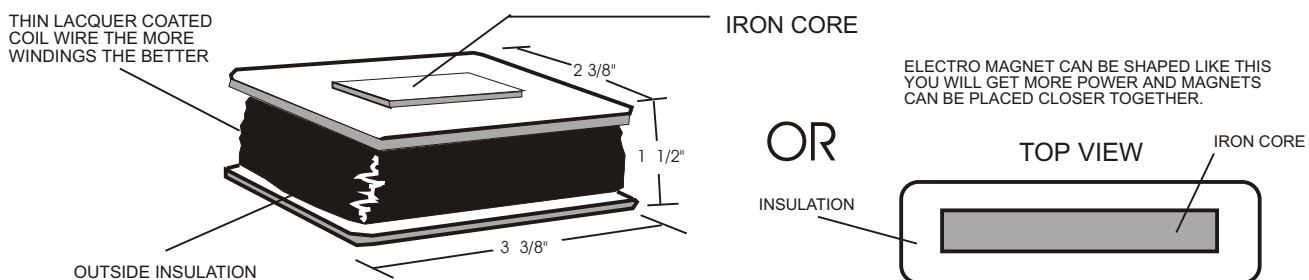

Use MDO board or some other strong thin wood for your coil bobbin, on our one horsepower motor we used 1/8 pvc sheeting, made a square center and then glues the top and bottom onto it using PVC pipe glue. Again this motor can be built using plastic pvc air core magnets or soft iron core magnets. If you use soft iron core the high voltage input has more of a chance to arc and burn out your coil.

- 8-QTY 2,000 volt diode or diode bank, check the internet for Electronic supplies.
or you can make them your self, please send \$7.95 for plans # 4789
- 1-QTY TRANSFORMER (USE PRIMARY ONLY) OR CHOKE.

PARTS LIST CONT.....

400 volt x 470 uf electrolytic capacitors. Connect each capacitor in series using a soldering iron, or you can simply buy a 2,000 v cap.

The capacitors shown here are electrolytic type. The capacitors will charge very quickly, they will not store much amperage, because the finer the wire you use and the more turns of wire you use the less amperage will be used to run the motor. There are other options, the higher the uf of the capacitor the more amps it will store. It will take longer on start up to charge, but once fully charged your cap will discharge very slowly because your motor is designed to run at very low milliamps of power.

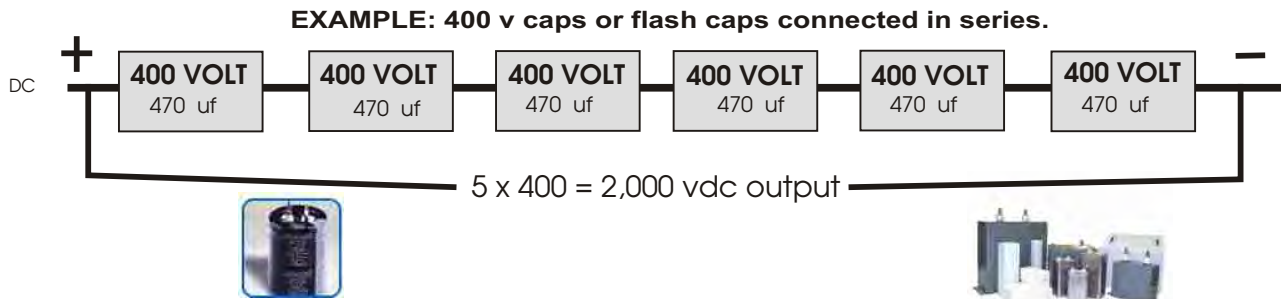

Suppliers: ALL ELECTRONICS CORP. 1-800-826-5432, INFORMATION UNLIMITED 1-800-221-1705
CAPACITOR SPECIALIST 1-800-346-4652, RADIO SHACK (They will give you qty prices)

2- QTY BALL BEARINGS FOR CENTER SHAFT TO RIDE ON: You will need a 3/16" bore size or what ever diameter you choose to use. we're using 3/16" but 5/8" is easier to work with since it's a standard pulley size.

In this prototype we are using a garage door pulley that we bought at a hardware store

Bearing Co's

Graingers louisville, ky.
502-499-0001

Small Parts Inc. FL 1-800-423-9009

Bearings Inc. louisville, ky.
502-637-1444

ask them for a catalog

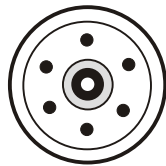

3/16"bore D x 3" D

Take your 1 1/2" stationary shaft brace as seen on the front cover and drill a 3/16" hole. Then put your shaft thru it and put on your garage door roller bearing and mark your holes where you will need to bolt to the shaft brace. Then drill your holes.

Make sure you drill a bigger hole in the first center hole you made so shaft won't drag. Also all this must be done after you apply braces to drum. Be sure you measure it right to find your center for both braces.

Or If you decide to build a 1 hp or higher motor as on front cover, then you will need to use a 1/2" shaft with a 1/2" roller bearings.

1- QTY ROUND ROD METAL SHAFT X 3/16" (Heat treated would be nice)

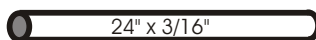

NEIL-LAVIEL STEEL CO. 502-456-2444 Or check your local phone book for metal and scrap metal co's

If you decide to build a 1 hp or higher use a 1/2" D round rod.

4 - QTY LARGE PC BOARDS , THIN ROSIN CORE SOLDER 1-ROLL, 100 WATT SOLDERING IRON QTY-1, FOR SOLDERING CAPACITORS AND DIODE BANKS.

1- QTY 15" DIAMETER X 12" DEEP X NO LESS THAN 1/8" THICK STEEL OR WOOD DRUM. THE ONE WE USED FOR OUR PROTOTYPE WAS A WOOD DRUM FROM A LUDWIG DRUM SET. (This prototype is designed to be scaled up or down.)

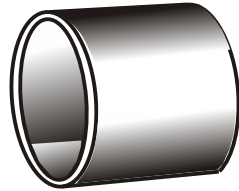

NOTE: LOOK AT METAL SCRAP YARDS (INDUSTRIAL) THEY COST ALOT LESS, THAN BUYING THEM NEW. IF THEY DON'T HAVE YOUR SIZE THEN JUST RECUSTOMIZE OUR PLANS TO FIT YOUR BUDGET.
YOU CAN ALSO USE 15" PVC SEWER PIPE.

14- Nuts and bolts to hold down magnets onto drum, about 1/4" x 2"

1- 12 volt DC 60 to 100 amp generator for keeping up an inverter battery system or you can use a 10,000 watt 120 volt ac generator..

1- 8" X 5/8" ALUMINUM PULLEY GRAINGERS WILL HAVE THEM OR A HARD WARE STORE. IF YOU USE A 5/8" PULLEY WITH THE 3/16" SHAFT YOU WILL NEED BRONZE BUSHINGS OR STEEL SLEEVES TO FILL THE GAP. (OR USE A 5.8" SHAFT.)
 For larger horse power engines, use a larger diameter shaft.

1- STEEL ANGLE 1 1/2" X 36" L, THIS IS FOR YOUR MIDDLE CENTER ROTOR BRACE FOR THE SHAFT AND THE ROTOR AND MAGNETS, YOU NEED TO CUT 2 PIECES TO WHAT EVER YOUR CENTER STATOR DIAMETER IS AND THEN BEND THEM LIKE SO:

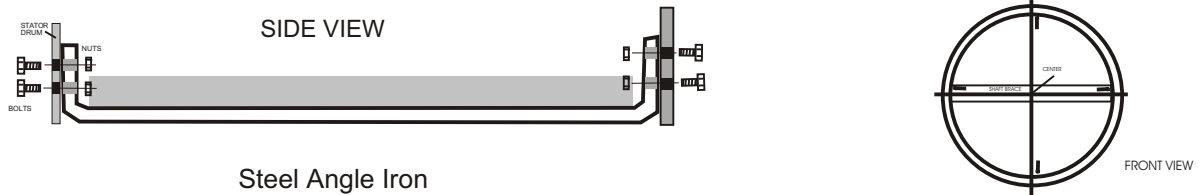

Steel Angle Iron

ATTACH TO YOUR STATOR DRUM FRONT & BACK CENTER AS WELL AS YOU CAN. THEN MEASURE IN A CROSS SECTION TO GET YOUR CENTER MARKS ON THE BRACES. THIS MUST BE AS ACCURATE AS POSSIBLE, USE A VERY SMALL DRILL BIT TO START IT SO YOU WON'T LOSE THE CENTER MARK..

1- 12 VOLT ON/ OFF SWITCH AND A ON OFF KEY SWITCH

4 - SPARK PLUG WIRES, TO ATTACH TO SPARK PLUG AND TO CAPACITOR BANK.
 YOU CAN USE THE TYPE A LAWN MOWER USES, SOLD AT HARDWARE STORES, THEY WORK BETTER.

1- 500 OR 1,000 WATT INVERTER, CONVERTS DC BATTERY TO AC 115 VOLT 60HZ to a diode and cap multiplier which in turn charges the 2,000 volt capacitor or cap bank.

1- 10 feet of small strand wire, insulated, 10 feet of red wire and 10 feet of black wire.

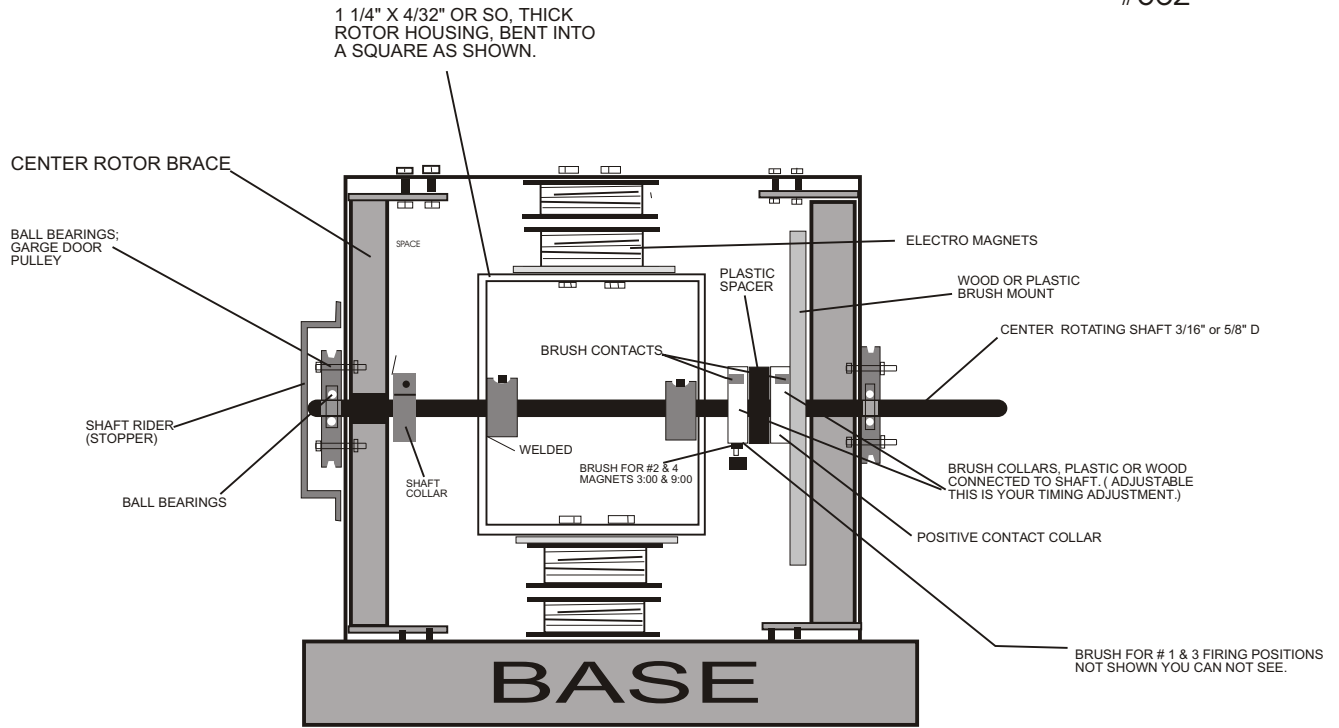

Positive CLOSE UP OF BRUSH ASSEMBLY

NEGATIVE WILL BE THE SAME AS THIS.

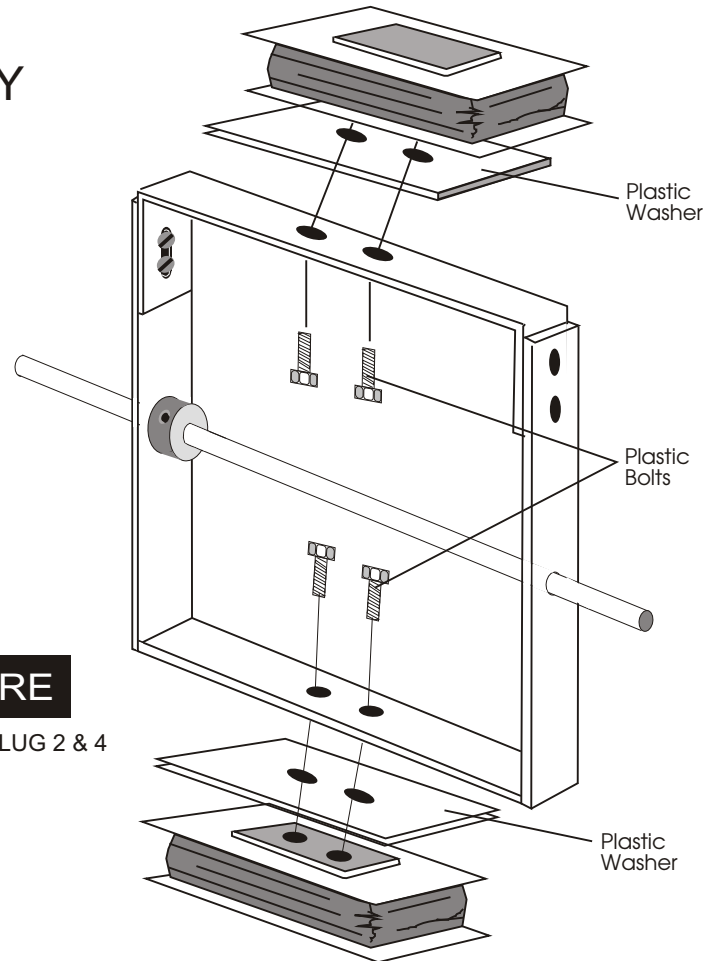
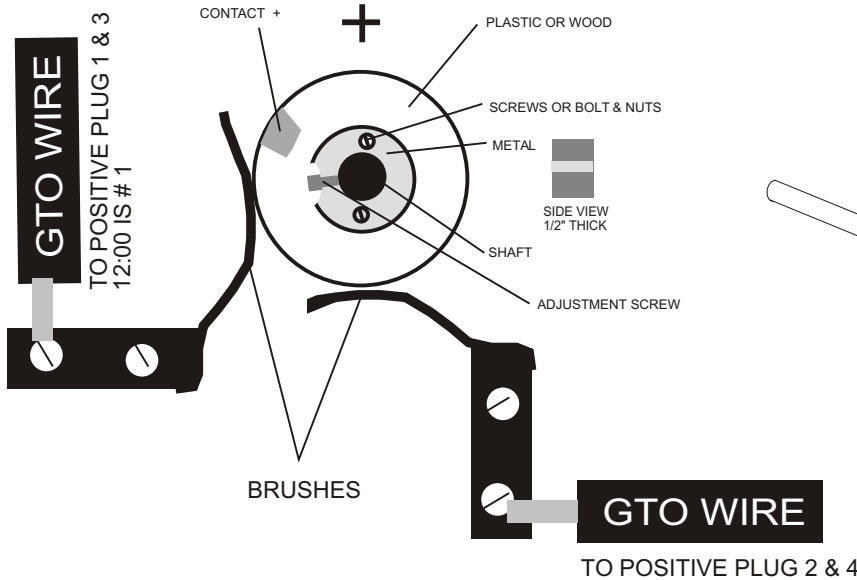

Use GTO wire to hook magnets up to brushes and any other connections were high voltage is to pass thru.

Notice: You can also design this motor to run on rotor magnets or stator magnets, using strong permanent ceramic type. It is much easier to build if you use magnets on the rotor instead of HV electromagnets.

Timing the Fuel less Engine

#362

To get an idea of how a DC brush motor works, take apart any size DC motor and check it out. Study it carefully. Timing the Fuel less Engine: 1,000 vdc is applied to the brush assembly, the brush assembly acts as an on and off switch for each set of magnets. The brush assembly can be made in many ways. The timing takes place in two places, the spark plug caps or the commutator brush collar assembly. You will only need one 1,000 vdc charging and firing system that is rated at 1 to 3 amps, the more amps the better, but the more danger to you during assembly. You can experiment around with a low milliamp cap bank and power supply, 10 ma is safe to use. You will need two spark plugs, two sets of capacitor banks or capacitors and one or two diode banks. One diode bank is for the Positive side and optional a 2nd is for the negative side. When the rotor arm magnets #5 & 6 are in the 12:00 position contact should be made to fire #1, #5, #6 & #3 magnets all at the same time. Wire these magnets so they are north pole to north pole, or north to south which will cause motor to then be an attraction motor. Many think that an attraction motor is better? But if you are using this as a repelling motor then time the firing when the arm #5 is just 1/16" past the center of #1 stator magnet. This will insure that the rotor arm will be pushed and rotated to the left and rotate counter clock wise. If timing as an attraction motor, you will want #5 to fire at about 3 to 4 inches before it gets to #1 magnet. This motor can be times to run clock wise as well. Collect all back emf per coil using a diode and capacitor per magnet, on the negative side outputs. It is strongly recommended that you build our 1 hp motor to get more understanding of how to build this motor.

If you choose to use a spark plug, you can gap the spark plug to fire a little early which will cause your power up time to be less, But you will have less shaft torque (HP). In other words you will have more RPMs but with some what less Horse Power, Now this is not real bad because it depends on what kind of generator you're going to use.

Please NOTE: the engine must be timed just right so the rotor magnets do not repulse each other too soon. Repulsion must take place at center or 1/16" past left or right. (This prototype uses a 115 volt AC generator, Please note: This engine design rotates to the left only, (counter clock wise.) You can design it to rotate both ways. Also Note: A & B Magnets connect to the same + & - Brush Rotor Assembly.

Update: See our new and easy way to make a homemade commutator which should be included with these plans.

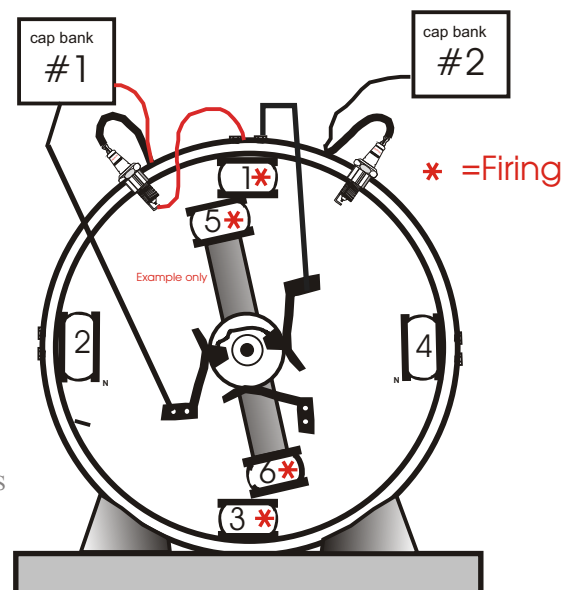
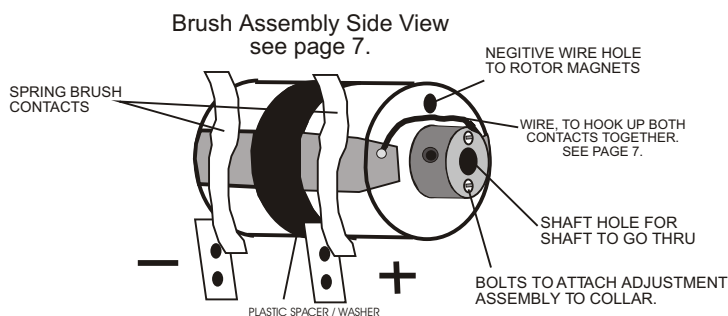

NOTICE: If you are having trouble understanding all of this, please keep studying it and do some small scale experiments to help you. PLEASE NOTE: WE DO NOT HAVE TIME TO GIVE YOU ANY TECHNICAL SUPPORT, THIS ENGINE DOES WORK, MANY ALREADY HAVE WORKING MODELS. The Library is loaded with books on electronics, electrical engineering, electric motors etc... children's books have the most for learning the 1st basics. Please do not attempt this engine unless you have some head knowledge in High Voltage and electricity. PLEASE BE CAREFUL ALWAYS WEAR RUBBER GLOVES AND SHOES WHEN WORKING AROUND HIGH VOLTAGE.

Creative Science & Research Copyright 2002

785VrtxP

Our 1 hp DC Motor / For research purposes only!

Brush Assembly Part F

Sorry Photo needs to be updated, Brushes are on wrong side, see plans.

Commutator
On /Off switch

*Sorry Photo needs to be updated,
Wrong Commutator see plans.*

Powerful Ceramic
Magnets Qty-2

Silicon or J-B Weld
to glue 2 magnets
to shaft.

Part " C " The Rotor Shaft

Part Q

ROTOR SHAFT ASSEMBLY

Part D & E
Support Arms
for Rotor Shaft

Part " M " Brush Assembly
Holding Bar. (Steel)

Part " A " Motor Base

Part O "
The Control Box

Part "R " Transformer Electromagnet(s)
you will need to take apart a transformer and
build yourself.

#16 gauge or #18 copper coated wire, used in research for
collecting electricity from electromagnet and as a magnet it self.

TIMING
Commutator and Brush Assembly

Build this simple DC motor as a test model before you build a large 15" Fuelless Motor / engine.

SIDE VIEW

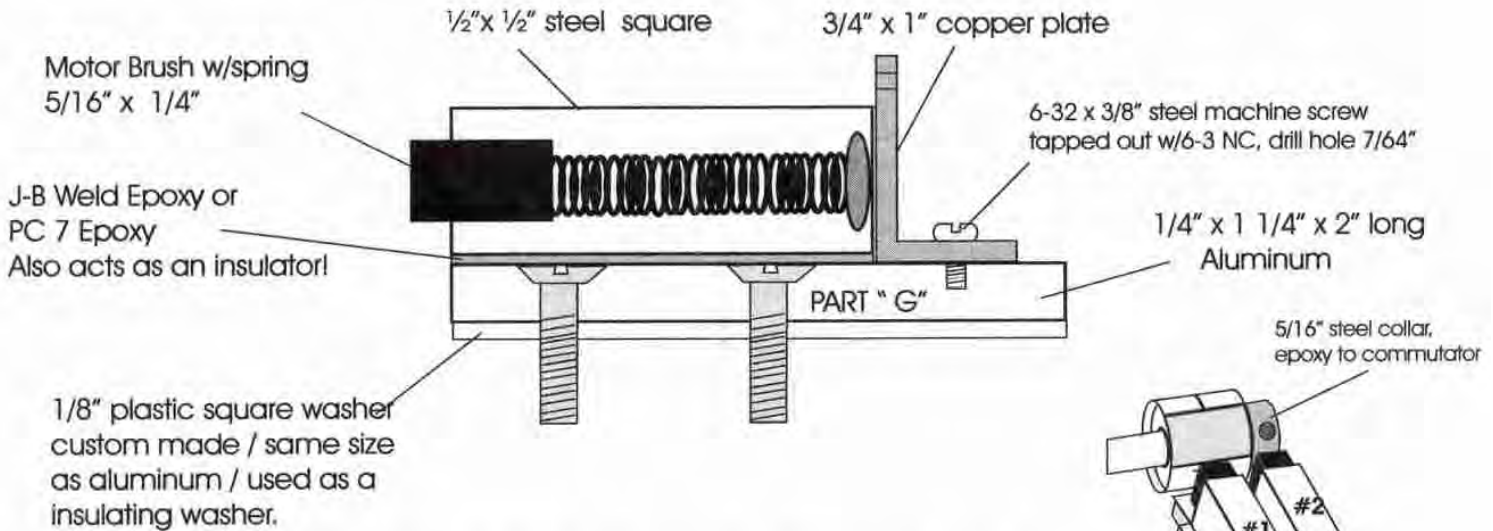
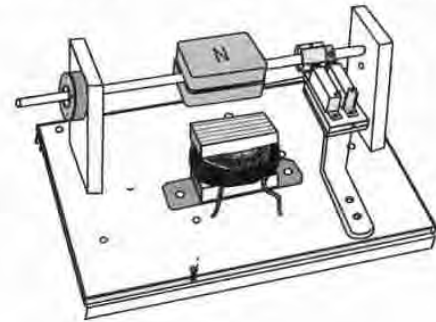

The #1 and #2 brushes must not be electrically connected, The epoxy under each steel brush holder will insulate between the steel square pieces and the aluminum. Make sure to spread the surface with an even coat of epoxy. Epoxy glue each steel brush holder assembly to the aluminum brush holder base, part "G". Then spray paint.

The Brush assembly acts as an on and off switch and must be timed so that the motor runs smoothly and not against it's self. The commutator is special made, and as the commutator rotates the brushes hit the commutator contact bar making a complete Circuit.

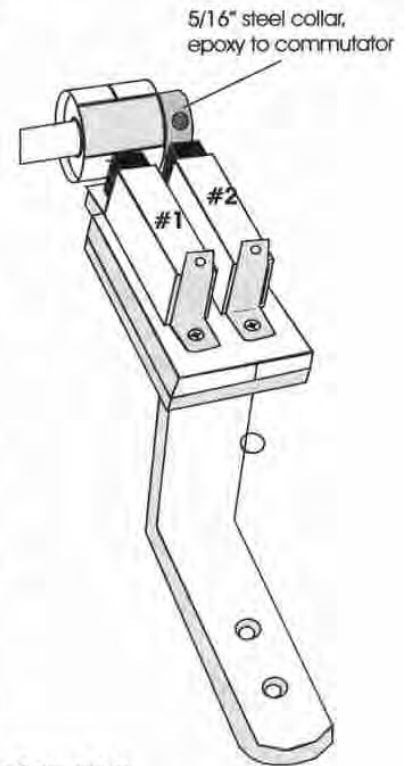

Top View

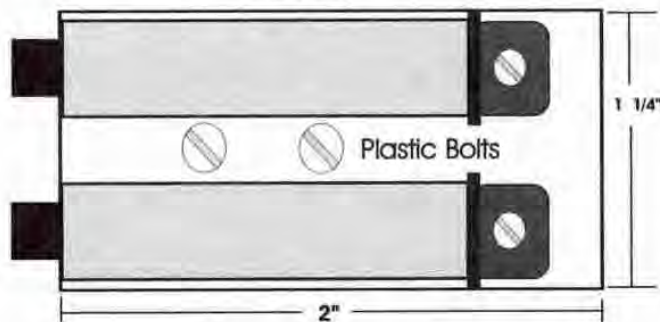

Copper Pipe Commutator

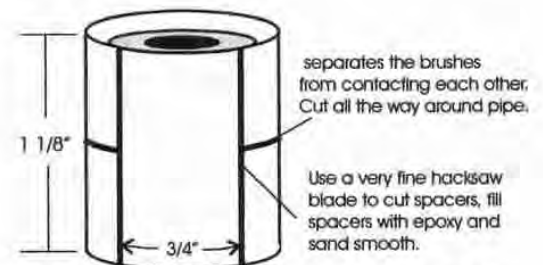

Rick's DC Test Motor for the Fuelless Engine!

362

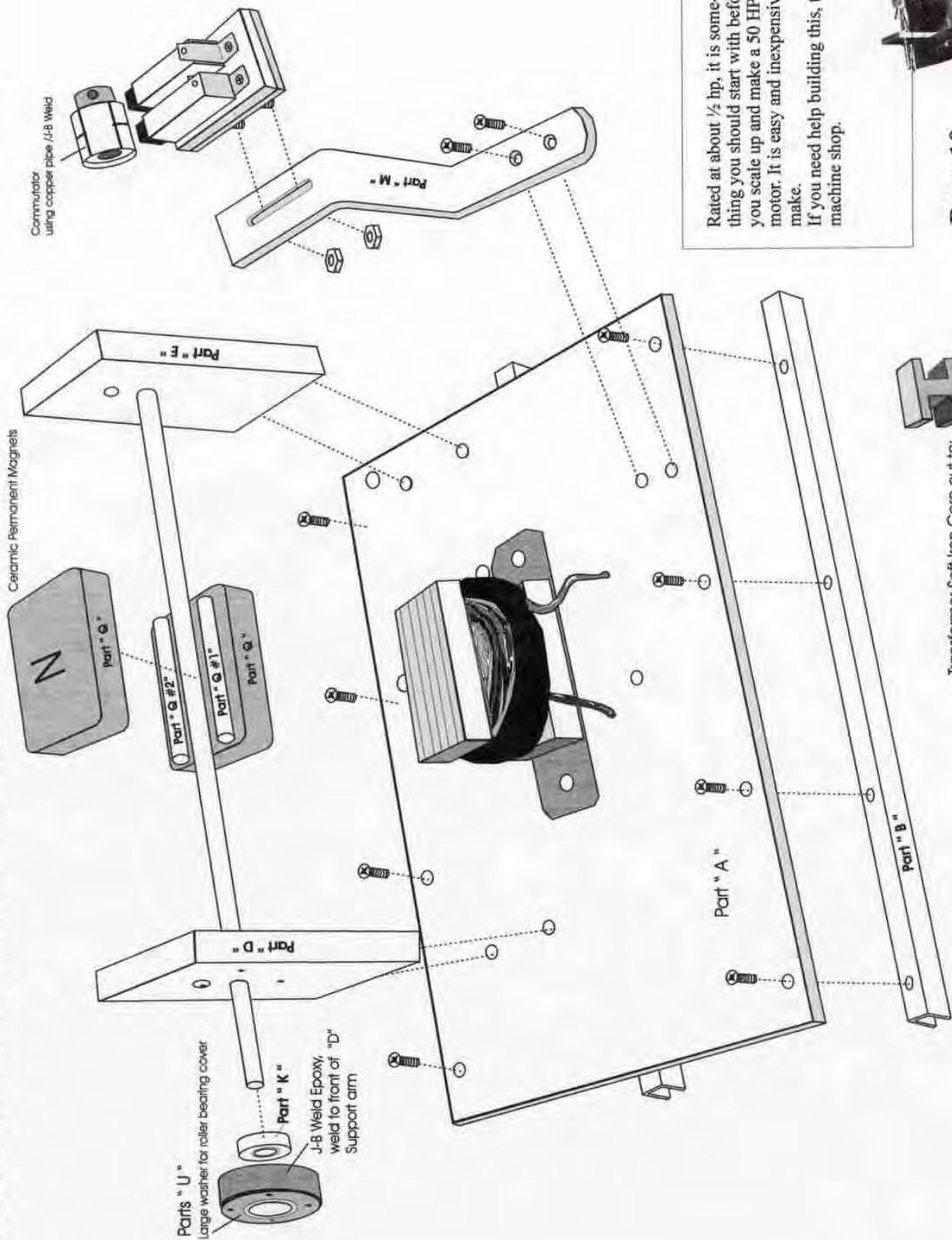

Rated at about 1/2 hp, it is something you should start with before you scale up and make a 50 HP motor. It is easy and inexpensive to make. If you need help building this, try a machine shop.



TIMING
Commutator and Brush Assembly

Timing your DC Motor is very important, if the electromagnet does not shut on and off at the right time the shaft will not rotate.

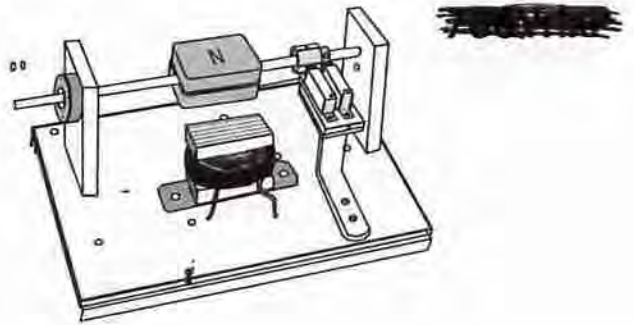

Mark Copper Pipe Commutator with a fine point permanent marker and then cut with a fine tooth hacksaw.

Copper Pipe DC / Commutator

Finish Here

Brush Should start here.

As would be seen hidden behind magnet

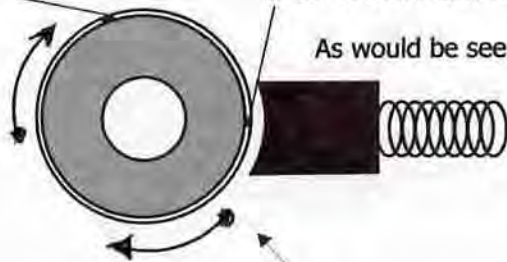

Start Position

Commutator switches ON!

OFF Position
Electromagnet must
shut off here, or shaft will
not rotate!

Electro Magnet

Epoxy $\frac{7}{16}$ " collar
to

Hex Bolt

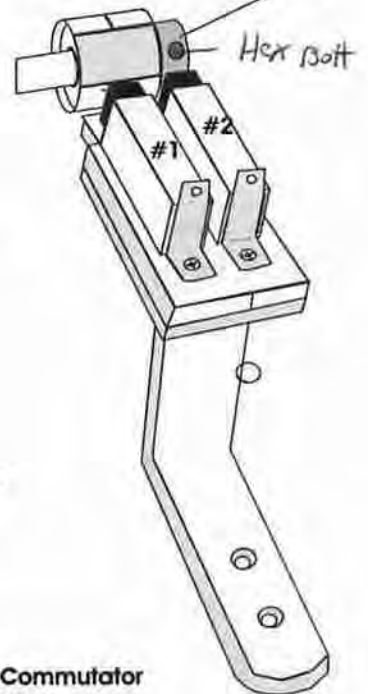

Copper Pipe Commutator
J-B Weld or PC 7 Epoxy fill

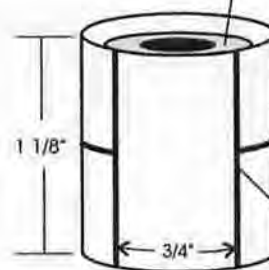

separates the brushes
from contacting each other.
Cut all the way around pipe.

Use a very fine hacksaw
blade to cut spacers, fill
spacers with epoxy and
sand smooth.

**BUILDING THE
COMMUTATOR**

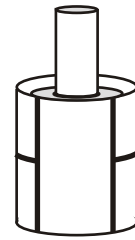

OPTION ONE

This is a homemade Commutator designed by Rick and Dave, This DC Commutator is used to turn off the incoming DC voltage to the HV Voltage or Low Voltage Magnetic Coil. We are going to create a junction bar that rotates and as it rotates it will slide onto the 2 carbon DC motor brushes and cause a complete connection causing DC current to flow into the Electromagnetic coil. We are going to give you 2 options in making a DC motor commutator. Pick which one is easiest for you.

STEP ONE

Cut a piece of 3/4" Diameter" x 1 3/8" length copper pipe that you can buy at any hardware store.

Use a pipe cutter to cut a piece 1 3/8" long.

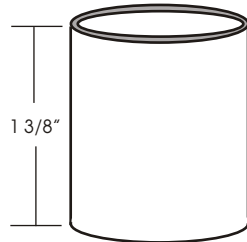

STEP TWO

Next using rough sand paper, sand the inside of the copper pipe really good. And then clean with laquer thinner. Surface must be free from dirt.

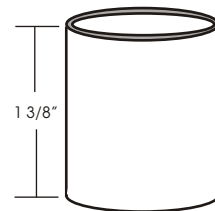

STEP THREE

Using a Q-Tip, Grease a piece of card board a little larger than the copper pipe diameter, this is so the epoxy will not stick to the Card board surface and can be removed when dry. You now need to fill the copper pipe with Epoxy, so slowly squeeze out enough J-B Epoxy to fill the inside of the copper pipe, follow all directions on the J-B Instructions, Mix the 2 parts very well and start placing the epoxy inside of the copper pipe. Let dry 24 hrs, I prefer to wait 40 hrs, but the instruction do not tell you that. We use J-B Epoxy because it is the best on the market and can stand up to 600 degrees.

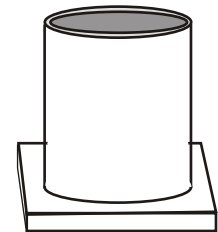
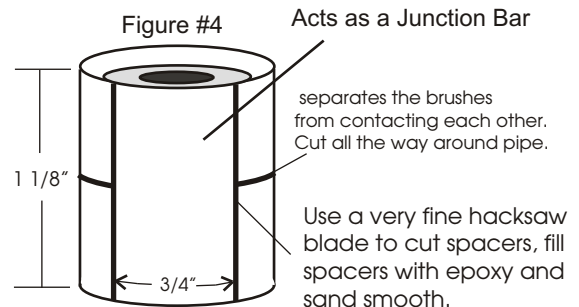

Figure #3

STEP FOUR

Now you must find the exact center of the pipe and score it with a sharp punch. You will be scoring or punching a small hole into the top of the epoxy. Now you are going to need a drill press. Place the copper pipe up as you see in figure #3, Make sure bottom surface is very flat, if it is not the hole will be crooked and the commutator will ride with the shaft crooked and cause a off balance at high speeds. start off with the smallest drill bit you have and work your way up until you have a hole the same size as your shaft rods outer diameter.



STEP FIVE

Now using a fine point marker, mark your cut marks on the outside of the copper pipe piece. As shown in figure #4. Use a fine tooth hacksaw to cut. Cut a long center cut all the way around the copper pipe leaving a 3/4" space. Cut all the way through the copper and just up to the hardened epoxy fill. Do not to deep into the epoxy fill.

Fill in the cuts with epoxy, let dry 24 hrs then sand down until smooth. Now take a 5/16" steel shaft and place it back into the epoxy hole, now place a steel 5/16" shaft collar onto the steel rod and epoxy it to the end of your new commutator, (remove the plastic end first.)

PART "F" BRUSH HOLDER

ASSEMBLY



Cut two 1 5/16" x 1/2" x 1/2" x 1/16" Square steel.

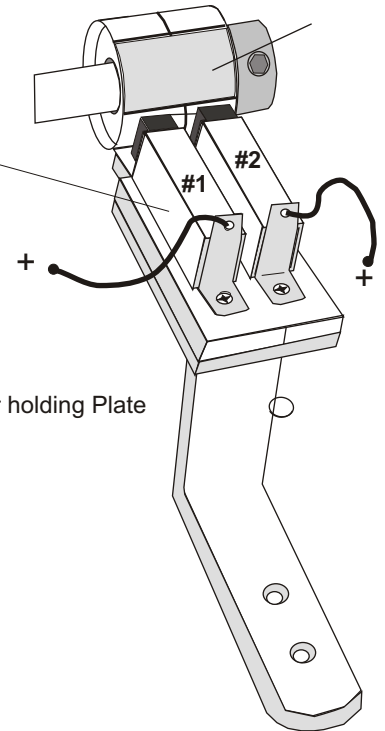
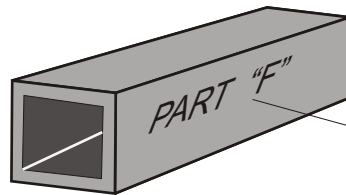
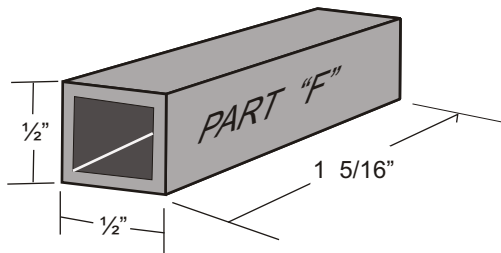

5/16" x 1/4" Motor Brush



J - B weld or PC 7 EPOXY



Copper holding Plate

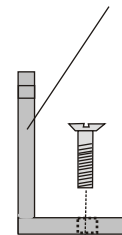

Plastic Separator

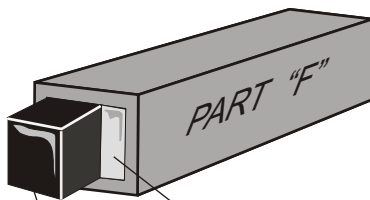

Fill with PC 7 Epoxy or J - B weld about 1/4" deep.

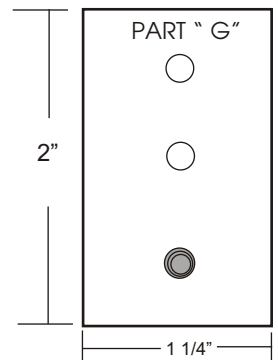
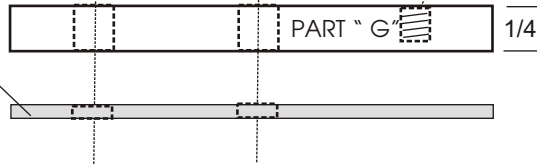

Brush: grease brush and place inside of square steel part # "F", Let sit and dry for 24 hrs, then remove brush and clean it off.

As an alternative to using brushes, you could replace with heat treated copper, which has some spring to it. Place the copper on part "M" and bend the copper upward.

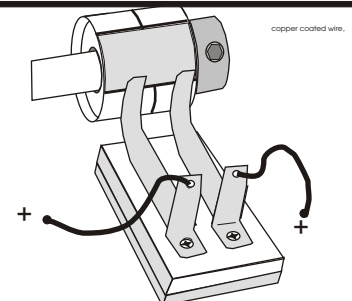

PART "M"
Brush Assembly
HOLDING BAR

Use a 8 1/2" x 3/4" x 1/16" or best to use 1/8" steel bar. This is used to hold the Brush Assembly.

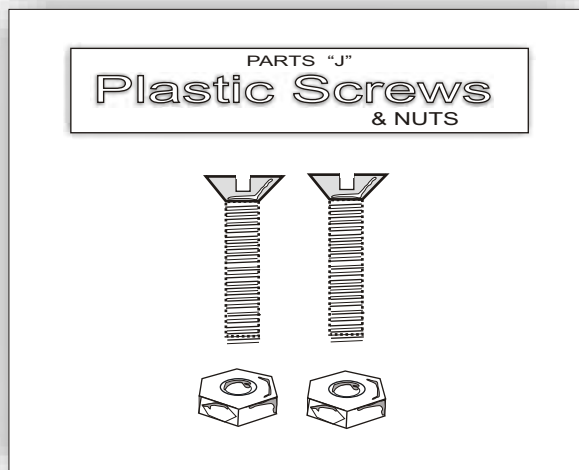
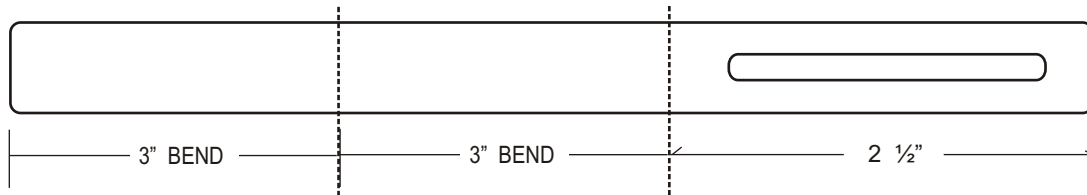

To attache Brush Assembly to holding bar.

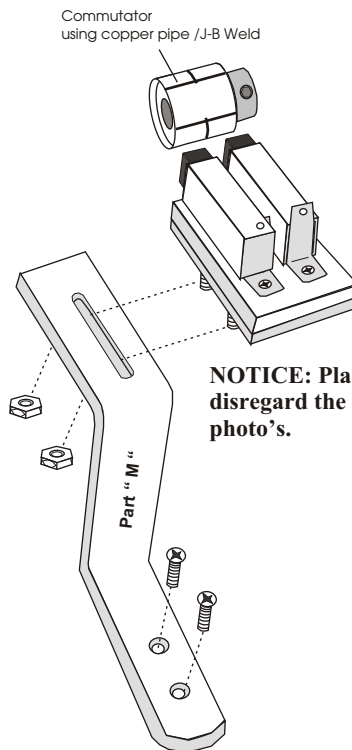
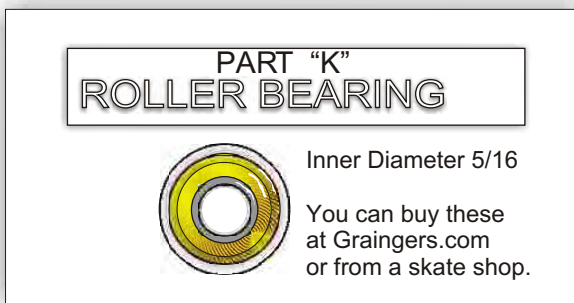

NOTICE: Place brushes in this position, disregard the brush set up in the color photo's.

PART "N"
SHAFT COLLARS



To fit 5/16" D or buy one and drill it to size 5/16"

You will need a qty of two. The first shaft collar is to hold the shaft into place, allow a 1/8" space or more between collar and Part "D" The 2nd steel shaft collar is to be epoxied (Glued) to one end of the finished commutator.

PART "B" BASE LEGS

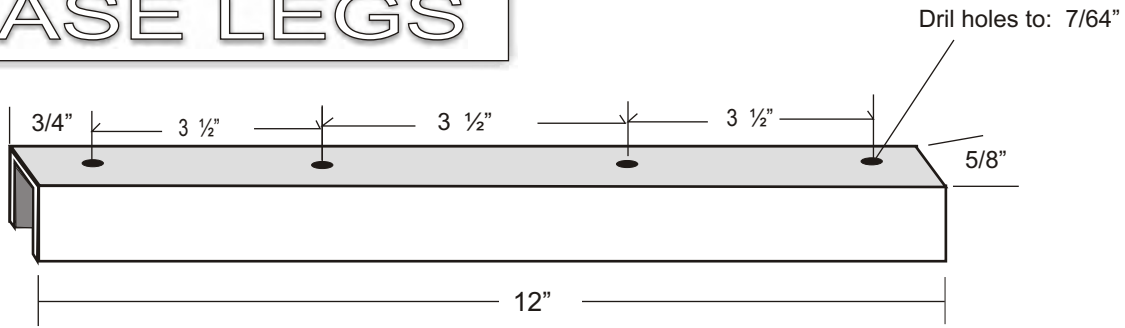

Aluminum 1/8" channel, check hardware stores, steel suppliers, lumber yards. Drill these holes at: Drill holes to 7/64". You will need a qty of - 2. You will need to tap out each hole, (Thread it) using a 6-3 NC tap plug style.



PART "C" ROTOR SHAFT

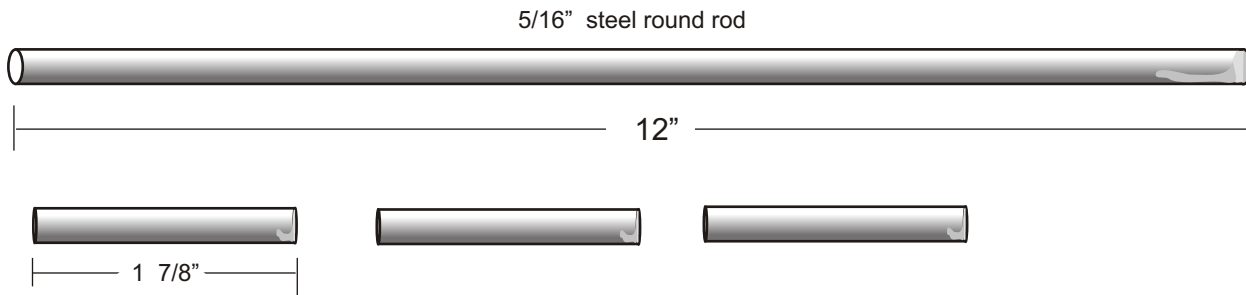

You will need three short pieces, two for the magnets to be used as spacers and one for a Shaft mold for making Commutator.

PART "D & E" ROTOR SUPPORT ARMS

Use 1/2" aluminum bar. Check at: Machine shops, Steel suppliers in your Yellow Pages, Steel salvage yards etc... Drill two holes on each arm, use a 5/16" drill bit. After you install roller bearing assembly on part " D ", remove roller bearing and drill a bigger hole using a 11/32" drill bit. On Part " E " Drill only halfway through, so the 5/16 rotor shaft can turn on it.

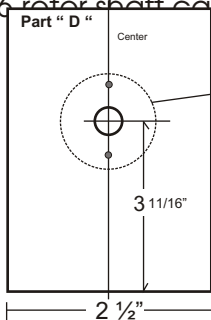

Roller bearing assembly, Use a large steel washer, assemble this after you put the Rotor shaft and arms together Once your shaft is running through Part " D " hole, you can then place the Roller bearing onto it. Grease the outer part of the bearing. Pre-drill 2 or 3 holes in the large steel washer, place the large washer over top of the roller bearing, center and mark your holes, use a 7/64" drill bit and tap out your holes with a 6-3 NC tap, then attach the washer to Part " D " with 6-32 x 1 1/2" bolts. Now mix up some J-B weld or Pc7 Epoxy and fill the inside beneath the washer and all around the roller bearing. (Make sure bearing is greased well so you can remove it to later drill your larger hole. The reason you need to drill a larger hole later is so your rotor shaft can turn more easily. Let epoxy dry for 24 hrs, then remove your Steel washer roller bearing plate, then remove your roller bearing, drill a bigger hole in Part "D" then place you bearing back onto the molded roller bearing assembly.

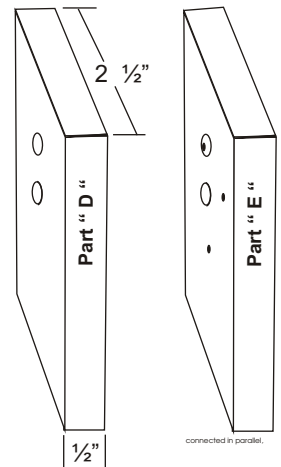
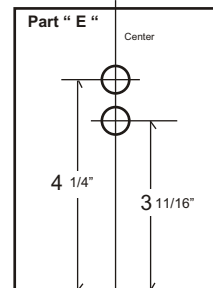

This is a research device, Capacitor and diode ratings depend on the voltage input vs what size coil wire used and # of winds. If you use a coil that is wound several thousands of times with number 38 or 36 copper coated wire, you are going to need to use voltages from 1000 to 3,500 vdc input. The back emf will be great. # 38 wire is hair thin and hard to wind but it is the best to use for a PVC air core type magnet.

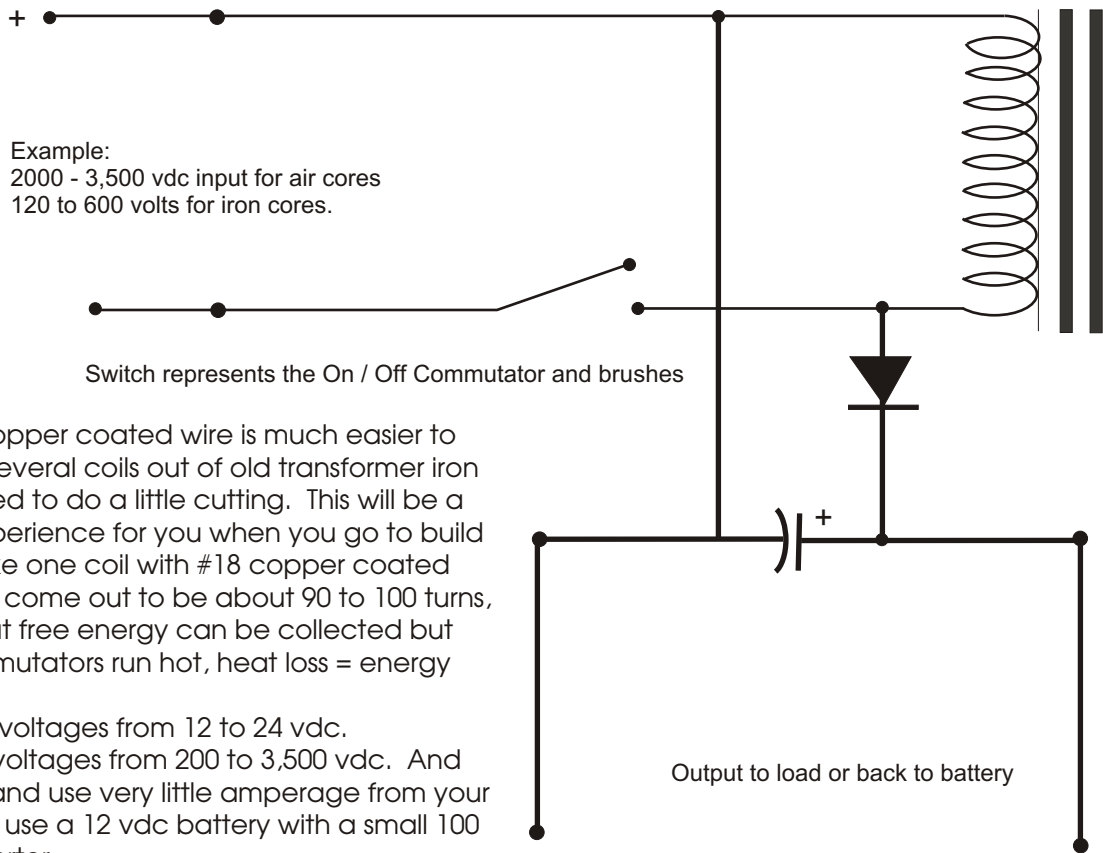

Using # 36 or 32 copper coated wire is much easier to work with. Make several coils out of old transformer iron cores. You will need to do a little cutting. This will be a great learning experience for you when you go to build a larger unit. Make one coil with #18 copper coated wire which should come out to be about 90 to 100 turns, you will notice that free energy can be collected but the coil and commutators run hot, heat loss = energy loss.

18 wire will take voltages from 12 to 24 vdc.
#38 wire will take voltages from 200 to 3,500 vdc. And will run very cool and use very little amperage from your DC power supply, use a 12 vdc battery with a small 100 watt dc to ac inverter.

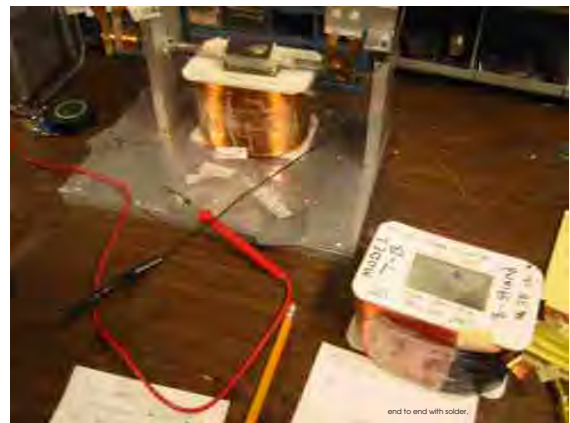

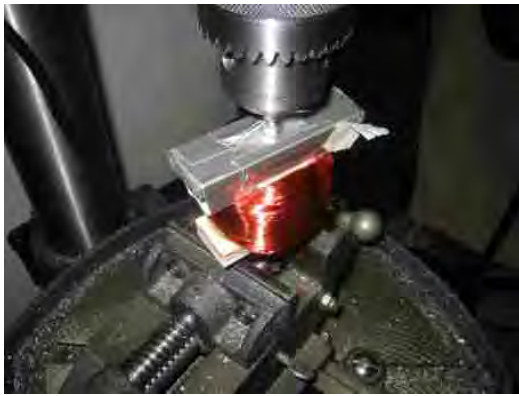
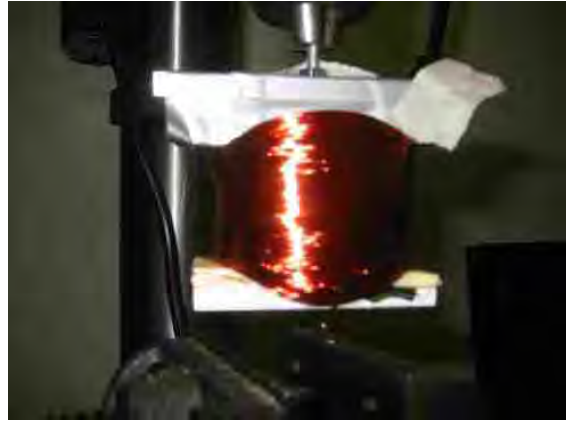

PART "P"
COPPER COATED
Magnetic Wire

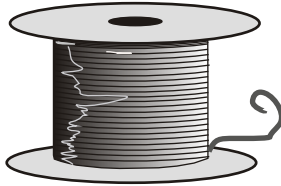

You will need 3 different rolls of wire.
16 or #18 gauge, # 26 or close to,
36 or # 38 hair thin wire.

You will need Copper coated wire to wrap around your soft Iron Cores, You will want to build up to 4 different Electromagnetic Coils with different size wire for study and research purposes. Teachers show your students the different effects and outputs that this Motor Generator will make by using more turns of wire vs less turns and the wire size. Make your Magnets interchangeable. Collect the Back Emf to and use the Vortex Effect to show your students how to get Free Energy out of these motors.

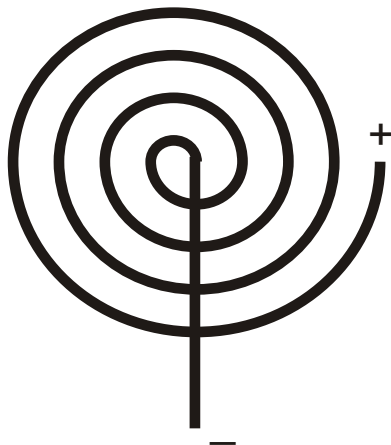

Use #16 gauge or #18 Gauge copper coated wire to make a Spiral. demonstrates an amperage hog motor, Place this Spiral under the motor shaft. Run test and note what happens.

To make a Spiral coil, use two pieces of flat plexi glass or MDO board, drill a center hole in both, sandwich the 2 pieces together leaving a metal or cardboard spacer in between the 2 boards, the spacer washer must be the same size thickness as the wire. Now place a bolt in the center hole and attache a nut. Now drill a small hole nest to center hole so you can run the first part of your wire through, tape it down and begin turning wire.

Reversing polarity reverses the poles.

Produces a strong magnetic force without the use of a middle soft iron core!

PART "Q"
CERAMIC MAGNETS

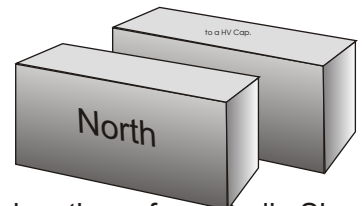

For this motor you will need 2 powerful ceramic permanent magnets, you can buy these from Radio Shack or search the internet for magnet suppliers. If you want to increase your horsepower then you must add more magnets to your shaft, on this motor you can get 2 pair. Make sure to redesign your magnetic coil structure to be longer. You can also design a large HP motor with Radio shack magnets by buying a hex shaped metal rod,  and glueing 24 magnets to it. This will also

Insure that your permanent magnets will last a very long time.

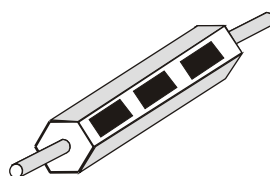
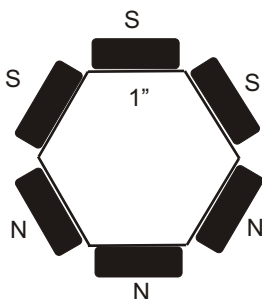

For the more advanced: Use a aluminum or steel Hex Bar, have a machine shop round off the ends to fit your end bearings. Epoxy each magnet onto the hex bar. Example length, 18 3/8" long. Use 1" hex flats. This will make for a very powerful free energy motor.



A letter sent in by a customer

To the technician
at Creative Science,

After studying your file, "The Fuelless Engine" I Downloaded, from the internet, a copy of U. S. Patent # 3,890,548 for further study. These devices, as stated, appear to work by the conservation of energy, and the electromatic coupling of energy, while collecting the electron moving forces of decaying magetic fields after physical work as been accomplished.

On page 8 of your file yhou state that you would apperciate any new ideas and findings. It seems easier to understand how this engine works with the concept of inductance in mind. Your file arranged like this might be easier for the layman to understand.

I noticed in the descriptions of the illustrations in Ed V Gray's patent, something that wasn't apparent at firsts. Number 32 in figure 1; is a second complete charging system! That leaves me to believe that power might flow through the system like this.

POWER ROUTE

Figure 1

Sub Figure

10	Battery one		Battery two
16,20	Charging system one		Charging system two
21,21a	Diodes(bottom of sine wave 21a)	22,22a	Diodes(top of S. wave 22a)
23	Choke coil	24	Choke coil # two
26	Capacitor bank	25	Capacitor bank
28	Inductor(Magnets)	27	Inductor(magnets)
	E.M.F. to battery two		E.M.F. to battery one

In Ed V Gray's diagrams: see figure one; The sinewave(s) are split differently, see sub-figures 19a, 21a, 22a. This might be what he considers, "splitting the positive." He uses diodes (#'s 21 & 22) to rectify the positive's of two opposite, unidirectional sinewaves.

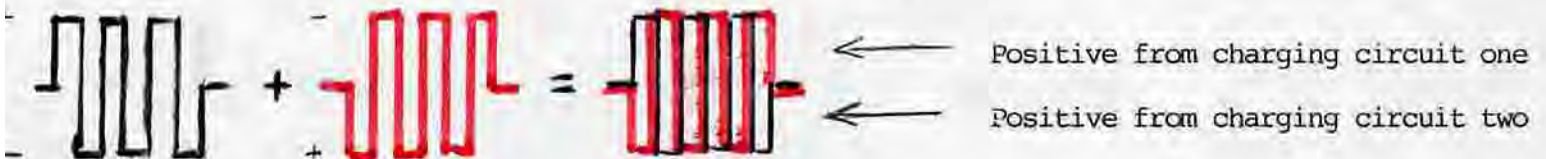

In my opinion the negative waves of these currents are transformed/harnessed as flux. The Inductors(#'s 23 & 24), along with the inductance of the magnets could influence the way the flux reacts in nature/reality. Splitting the positive(s) and exciting the currents into flux seems to be where the efficiency is achieved.

Your simplified model is sound in theory. However, the illustrations don't contain any reference to the DELAY COLLS/INDUCTORS of the charging systems, nor to the important role they play in the system. As I understand it, when current is increased in an inductor, the inductor generates a counter E.M.F. which opposes current build up. As current decreases, the inductor sets up a counter E.M.F. to try to keep the current going the same way. This is accomplished by the magnetic field expanding and contracting in the core of the inductor. This concept tends to cause the power to be "OUT OF PHASE". Ed Gray states in his patent, "which is believed to produce a static floating flux field." The word static, may be a reference to the way power flows at a molecular level. In the delay coils the inductance also seems to be applied as a flux(magnetic field? or?) and as a phase variant in how it interacts with other inductors (stator and rotor electromagnets). The floating part of it?? Hence, "static floating flux field". In the magnets power and current being out of phase seems to be how Ed V Gray has been able to recover so much energy. This may also help illustrate, "that something extra that is produced by high voltage that can't really be explained.

*362

- [54] **PULSED CAPACITOR DISCHARGE ELECTRIC ENGINE**
- [75] Inventor: Edwin V. Gray, Northridge, Calif.
- [73] Assignee: Evgray Enterprises, Inc., Van Nuys, Calif.
- [22] Filed: Nov. 2, 1973
- [21] Appl. No.: 412,415
- [52] U.S. Cl. 318/139; 318/254; 318/439; 310/46
- [51] Int. Cl. H02p 5/00
- [58] Field of Search 310/46, 5, 6; 318/194, 318/439, 254, 139; 320/1; 307/110

- [56] **References Cited**
- UNITED STATES PATENTS**
- | | | | |
|-----------|---------|---------|---------|
| 2,085,708 | 6/1937 | Spencer | 318/194 |
| 2,800,619 | 7/1957 | Brunt | 318/194 |
| 3,579,074 | 5/1971 | Roberts | 320/1 |
| 3,619,638 | 11/1971 | Phinney | 307/110 |

OTHER PUBLICATIONS

Frungel, *High Speed Pulse Technology*, Academic Press Inc., 1965, pp. 140-148.

Primary Examiner—Robert K. Schaefer
 Assistant Examiner—John J. Feldhaus
 Attorney, Agent, or Firm—Gerald L. Price

[57] **ABSTRACT**

There is disclosed herein an electric machine or engine in which a rotor cage having an array of electromagnets is rotatable in an array of electromagnets, or fixed electromagnets are juxtaposed against movable ones. The coils of the electromagnets are connected in the discharge path of capacitors charged to relatively high voltage and discharged through the electromagnetic coils when selected rotor and stator elements are in alignment, or when the fixed electromagnets and movable electromagnets are juxtaposed. The discharge occurs across spark gaps disclosed in alignment with respect to the desired juxtaposition of the selected movable and stationary electromagnets. The capacitor discharges occur simultaneously through juxtaposed stationary movable electromagnets wound so that their respective cores are in magnetic repulsion polarity, thus resulting in the forced motion of movable electromagnetic elements away from the juxtaposed stationary electromagnetic elements at the discharge, thereby achieving motion. In an engine, the discharges occur successively across selected ones of the gaps to maintain continuous rotation. Capacitors are recharged between successive alignment positions of particular rotor and stator electromagnets of the engine.

18 Claims, 19 Drawing Figures

200 HP

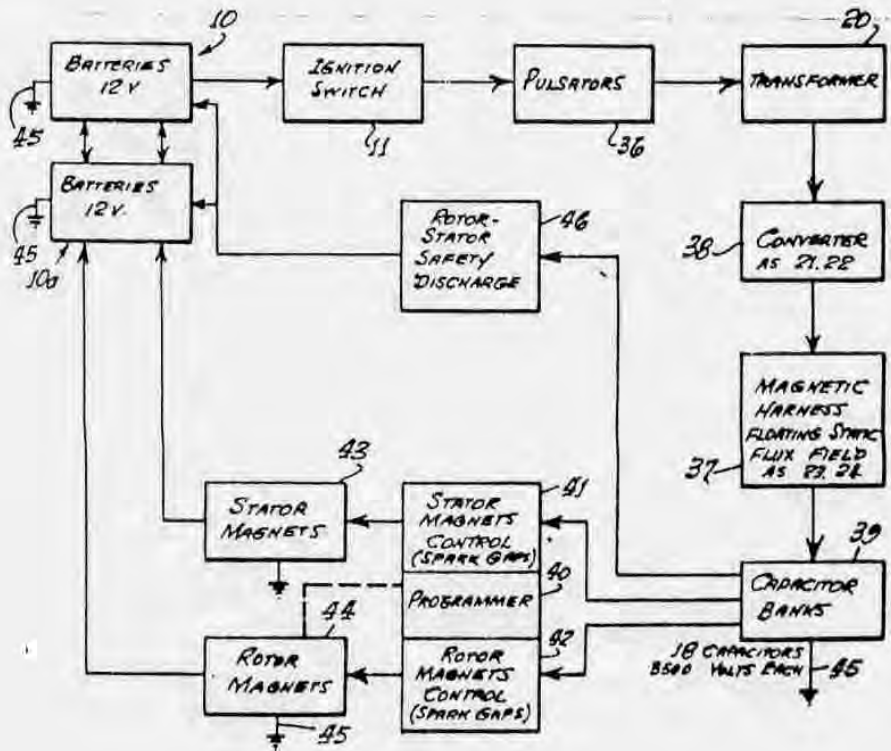

FIG. 8.

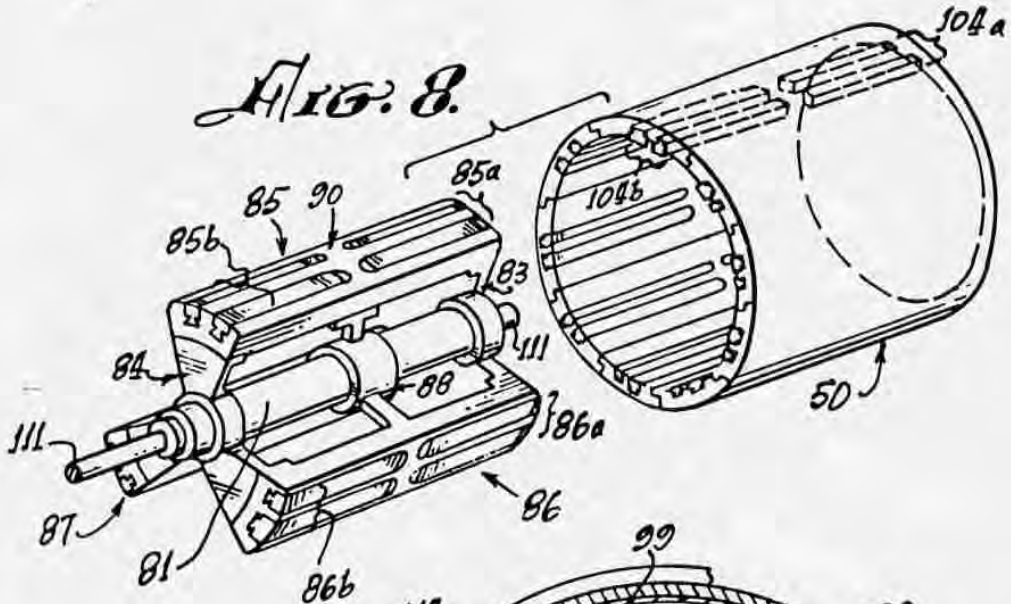

FIG. 9.

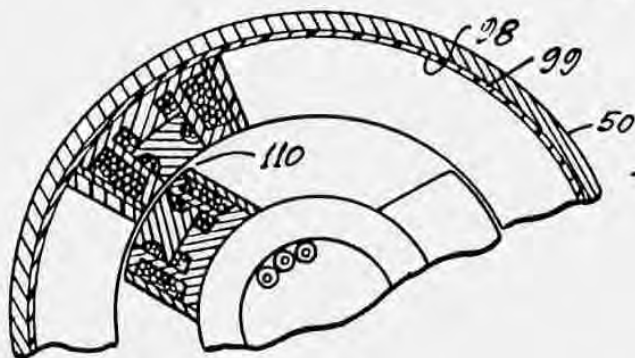
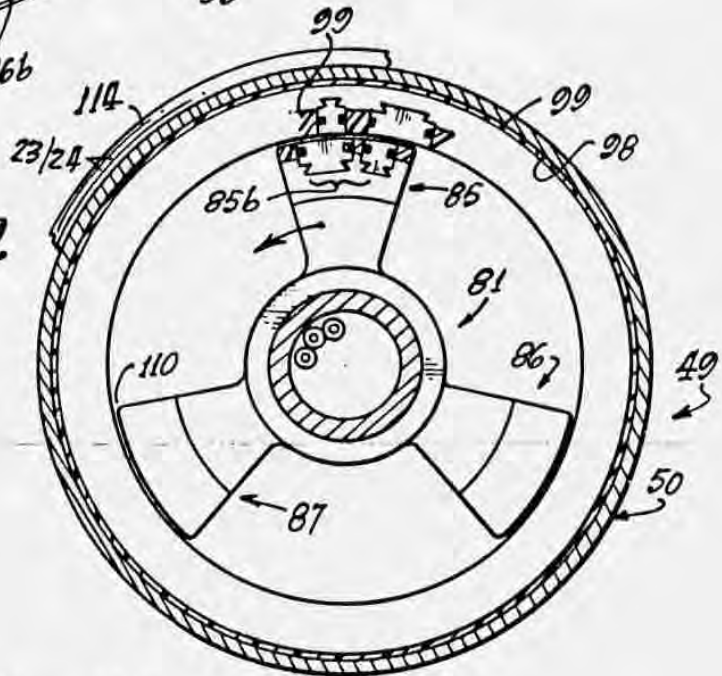
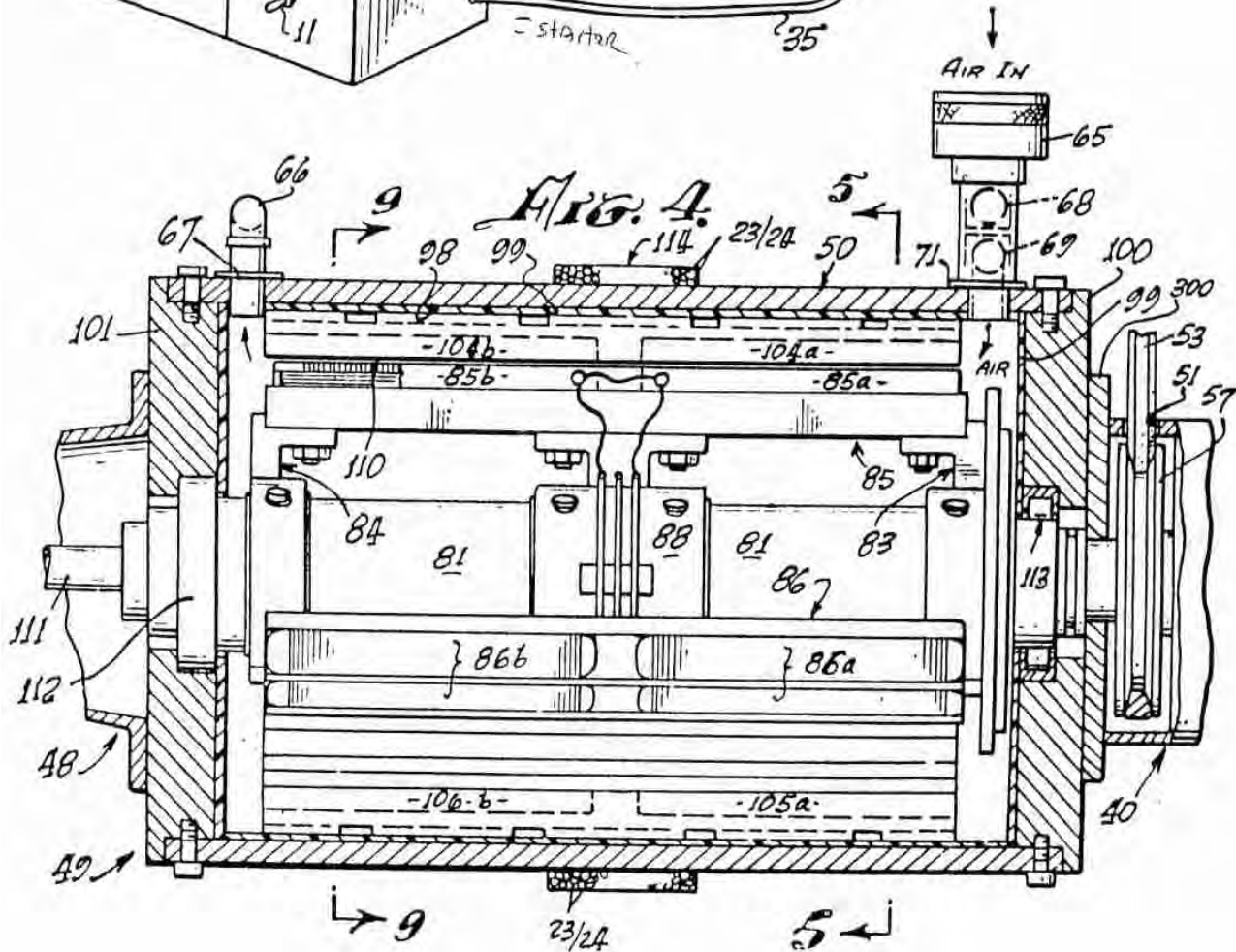
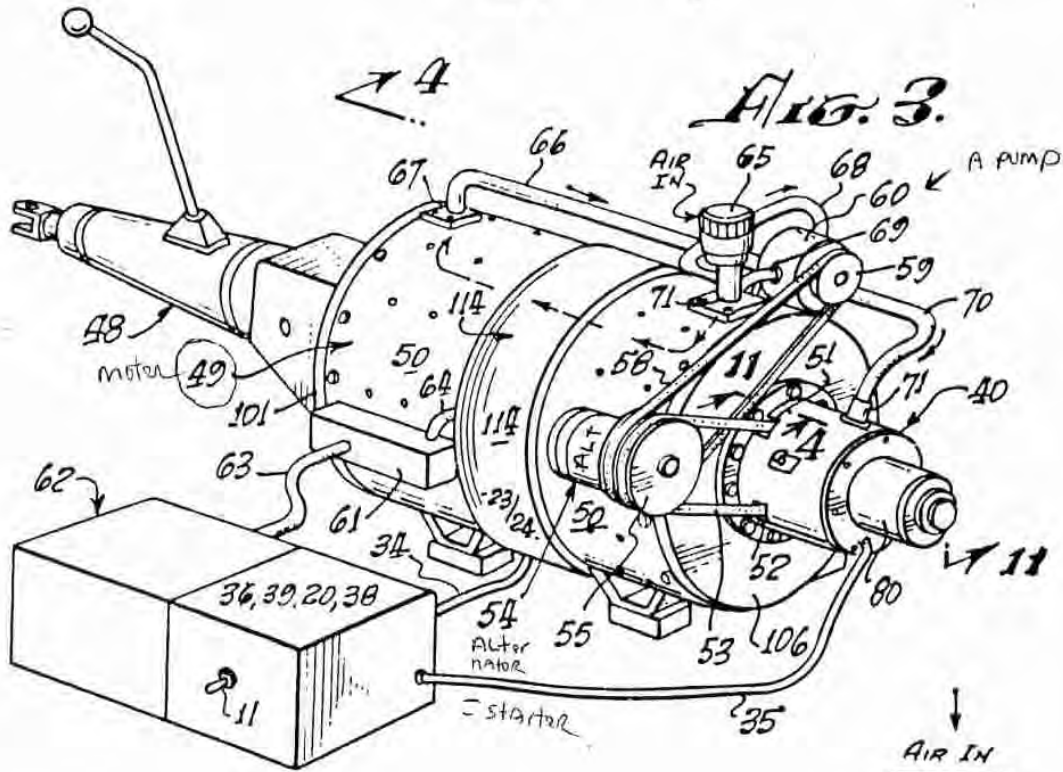

FIG. 10.



"magnetic vacuum," created in the drum, which literally takes the pressure off of end bearings and allows the rotor to float within the drum.

The motor created power surges—one behind the other—in micro-seconds. This allowed them to direct the magnetic flux field. The magnetic flux was a coolant source, so it did not need a cooling system.

The EMA's noise emission was far less than that of all other power sources, and Gray claimed there would be no increase in noise as the engine aged. In fact, electric-motor noise is almost imperceptible when properly suppressed.

The only external magnetic effect was that another field system couldn't operate within the same battery system. The magnetic field orientation is 360° in all directions.

Perpetual Motion?

According to EvGray, some experts believe the EMA is a perpetual-motion engine—that is, machinery that would produce continuous movement without any outside energy source—and is, therefore, invalid. The very concept of perpetual motion violates all known laws of thermodynamics.

Gray himself refutes this belief.

The EMA motor is definitely not perpetual motion. Only those in the scientific world who understand the theories of physics are able to comprehend how our motor works. There's only a handful of such persons.

EMA-4 MOTOR PRELIMINARY TEST DATA	
Input Power	12V dc (or a 24Vdc system using a 12V standard starter motor)
RPM	2550 RPM constant
Torque	66 lbs/constant
Horsepower	100 HP
Brake Horsepower	32.05
Foot-pounds/minute	1,057,650
Foot-pounds/second	755lbs (include 110 lbs for four TV batteries)
Volume	42" long x 18" wide x 22" high (Overall geometry including control unit, etc. — The basic motor is a 16" dia x 24" cylinder which can be repackaged into a 9" dia x 12" cylinder)
Test Run Time	21.5 minutes
Battery Volt Reading at test completion	25.7 volts
Ambiant Temp	84°F constant
Humidity	51%
Fuel Consumption	None (other than air)
Cooling	Conduction/ ½-pound (flow thru) air pressure
Magnetic Field Orientation	360° — all directions during motor operation
Lubrication	High temperature bearing grease (2 bearings)
Vibration	Negligible
Noise Level	No direct reading taken — without shielding, no louder than small kitchen appliance, eg fan, etc.
Start Mode	Simple push button — standard 12V starter motor
Operating Mode	Rheostat principle with switchable RPM range (500-1300-1950-2550-3360-4100 RPM's)
Physical Condition	Motor mounted on wheeled test stand — no external connections to stand.

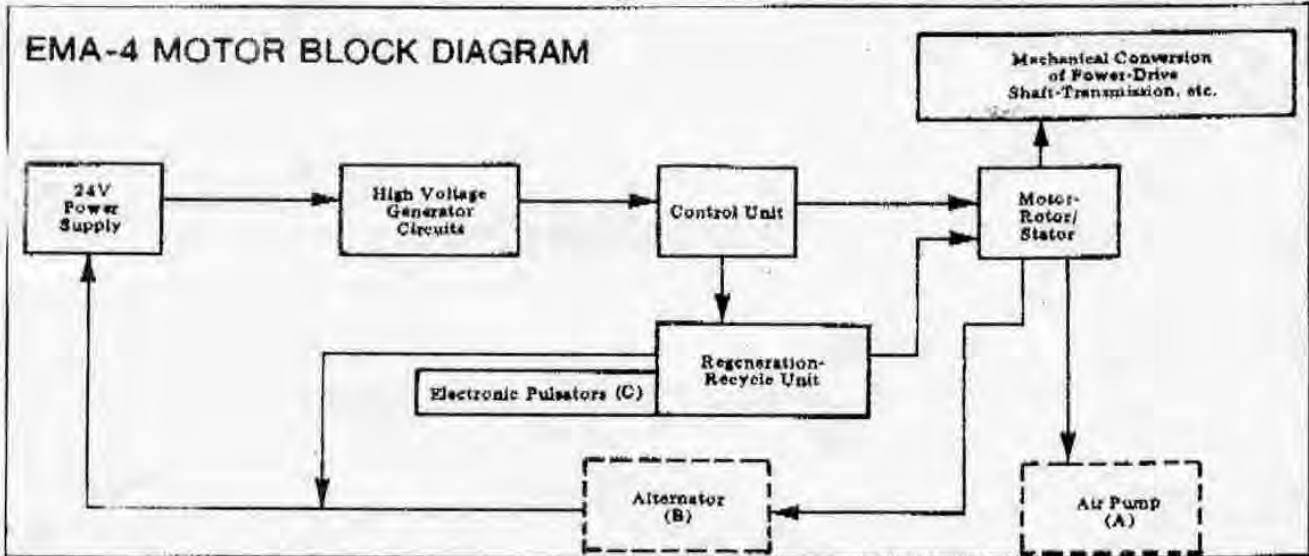

BLOCK DIAGRAM OF THE EMA-4 shows how energy is transmitted from the four 6-volt batteries (power supply) to the various stages of the engine and returned. Both the air pump (A) and the alternator (B) are optional equipment. The air pump prevents Condensation around the drum and provides added assurance of air in some environments. The alternator is not needed for most applications, including use in vehicles, but may be desirable in heavy generator rigs. The electric pulsators (C), which are contained in the regeneration-recycle unit, are capable of pulsing at 200,000 times per minute, and the pulsation at 80-120 amps is fed back to the batteries.

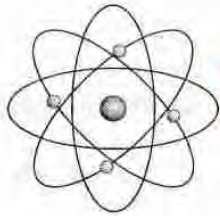

CREATIVE SCIENCE & RESEARCH

P.O. BOX 557 NEW ALBANY, IN. 47151

Information Big Brother & the Oil Companies do not want you to know!

KNOWLEDGE IS POWER!

4700 uF 35v

CONTACTS

RING

13 VDC coil 25 (no electromagnet)

SIDE VIEW OF 4 PC

2003

FREE ENERGY

www.fuellesspower.com

Time is running out