

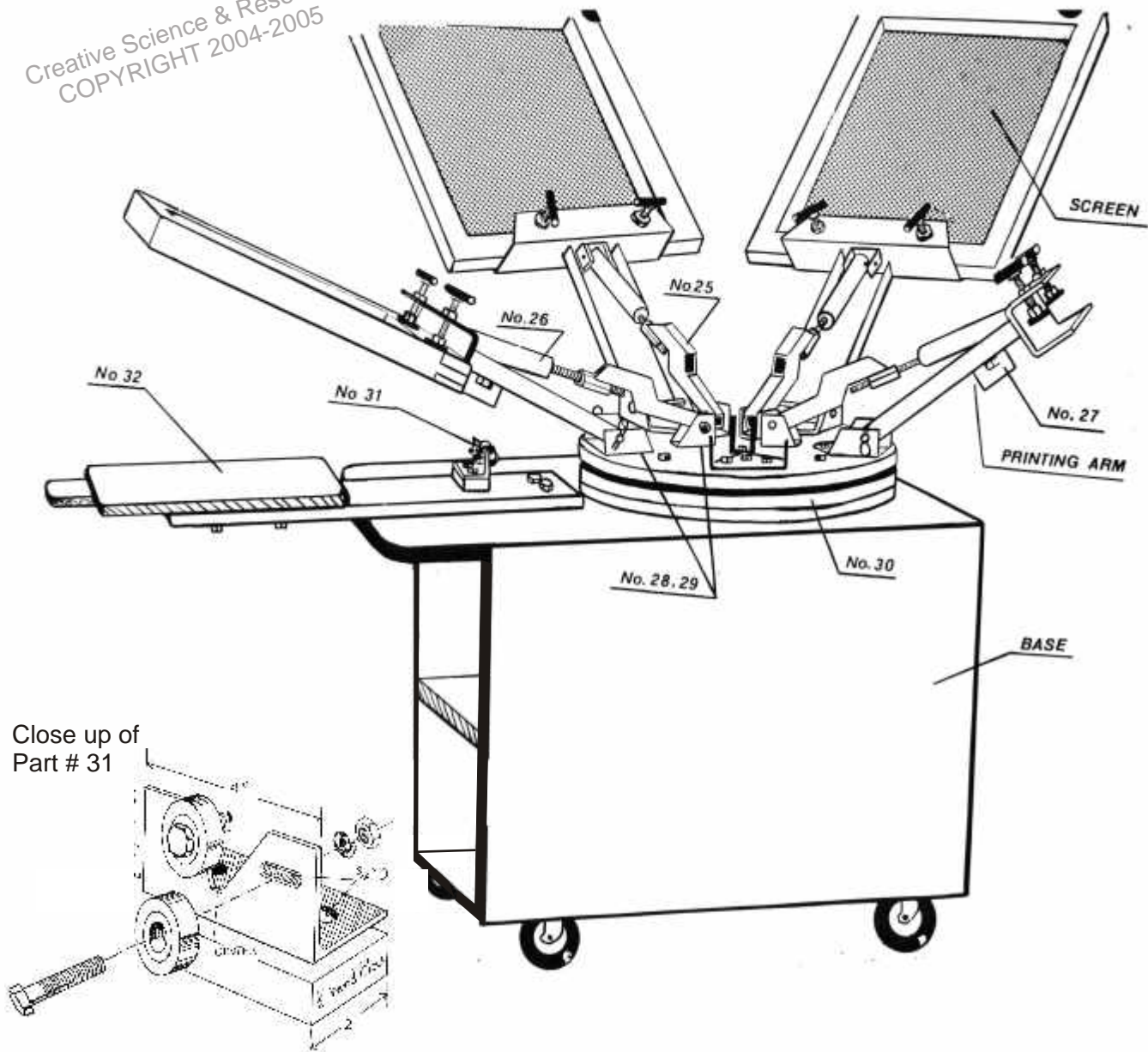

JC-M1 Screen Printing Press

Creative Science & Research
COPYRIGHT 2004-2005



Close up of
Part # 31



Creative Science & Research
COPYRIGHT 2004-2005



Creative Science & Research
COPYRIGHT 2004-2005



Parts and Supplies

You can buy metal parts from a metal salvage company, Hardware Store, Metal Supply Companies or a Machine Shop. Machine shops can also cut metal, weld, bend metal or anything else you may need, by the job or in whole! I have found you can get a better deal if you take a few parts at a time. You will need a hack saw, A jig saw with metal cutting blade, a drill press, or a band saw with metal cutting blade or you can have a machine shop cut the pieces for you, all you need to do is provide them with a good drawing of what you need done.

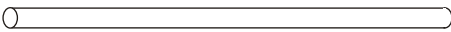
Part #	Qty	PARTS DESCRIPTION
1.	15	3/8" X 1" LONG.. BOLTS (coarse thread) with nuts, washers & locknuts.
2.	1	Welder, If you do not want to do your own welding have a machine shop do it.
3.	10	3/8" x 3" or 3 1/2" IONG. (coarse thread) with head screw. 
4.	1	1/8" x 20" Metal round rod. 
5.	10	Swivel Pads 3/8" D (coarse thread) Part Name Leveling feet

DIXIE INDUSTRIAL (LEXINGTON KY) www.dixiesupply.com
1105 NANDINO BLVD LEXINGTON, KY 40511
UNITED STATES Phone 800-422-2616 Fax 859-231-0639
Email info@dixiesupply.com ASLO SEE: Carrlane.com



6.	1	LAZY SUSAN Bearing type - metal turn table Supply Source: AceHardware.com or search the internet, keyword Lazy Susan.
----	---	---



6a.	1	65" x 3" x 3" Square metal tube Use about a 14 gauge. Cut to 12 7/8" lengths.
-----	---	--

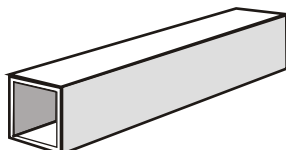

Lazy Susan

Creative Science & Research
COPYRIGHT 2004-2005



Parts and Supplies

Part#	QTY	Parts Description
7.	2	14 gauge metal U, 60" x 1" x 4" Supply source: Scrap metal yards, Machine shops, Metal supply companies you will need to cut a QTY- of 5 pieces cut to 12" lengths. Finished size: 12" x 1" x 4"

Creative Science & Research
COPYRIGHT 2004-2005



Side View

7a.	1	Flat metal 25" x 2 1/8" (For registration #27)
-----	---	--

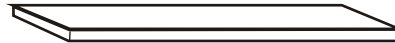

8.	1	55" length x 1" x 1" . (For arm Extensions #25) Use about 14 gauge also.
----	---	---

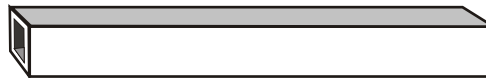

9.	1	Round Metal Tubing (for spring arm cylinder) 1 1/8" Diameter You will need to cut 5 pieces to 7 1/2" lengths. You can use thin metal such as electrical conduit pipe or other. Supply Source: Metal supply companies, internet, machine shops, www.smallparts.com
----	---	---









10.	5	Push Springs:  30 lbs or less 7/8" D x 4" L
-----	---	--

11.	5	Long Bolts with washers (coarse thread) 3/8" x 8" L
-----	---	---



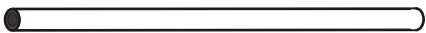

Parts and Supplies

Part#	QTY	Parts Description
11a.	5	Bolts (Coarse thread) 1/4" x 2 1/2" L. With lock nuts and washers. 
12.	5	HL Nuts  3/8" x 1 1/2" These are for adjusting the spring extension arms. Long bolt hex nuts
13.	1	Metal round rod 3/8" x 36"  cut to a Qty of 5 - 6" Length pieces
14.	6	Carter Pins 
15.	5	Heavy long nails 3 1/2" Length. These are for attaching spring arm to attachment 7 -27 for printing arms #6-a
16.	5	Metal U 14 gauge.  1 3/16" x 2" 1" This is for attaching spring arms to printing arms #6-a attachment 7-27 FRONT VIEW
17.	2	Roller Bearings 3/8" for registration #31  www.Graingers.com
18.	2	Plywood or particle board (as used by cabinet makers) 4' x 8' x 1/2" thick or 3/4" thick. This is for the base of the printer.
19.	4	Heavy Duty Roller wheels, to attach to bottom of plywood base.
20.		Wood glue, C clamps, Hammer, Tape measure, Jig saw, Drill press.
21.	1	15" x 15" x 1/2" or 3/4" thick Particle board or plywood topped with Formica plastic as used by cabinet makers. This will be the printing table base that extends from printer.

Creative Science & Research
COPYRIGHT 2004-2005



PRINTING ARMS

Figure A #24

Part #6-a Use a jig saw with a metal blade or a hacksaw. Cut part 6-a to 12 7/8" smooth all edges with a file. Remember you can get a machine shop or metal supply company to make the cuts for you. You will need to assemble a total of 5 arms #24

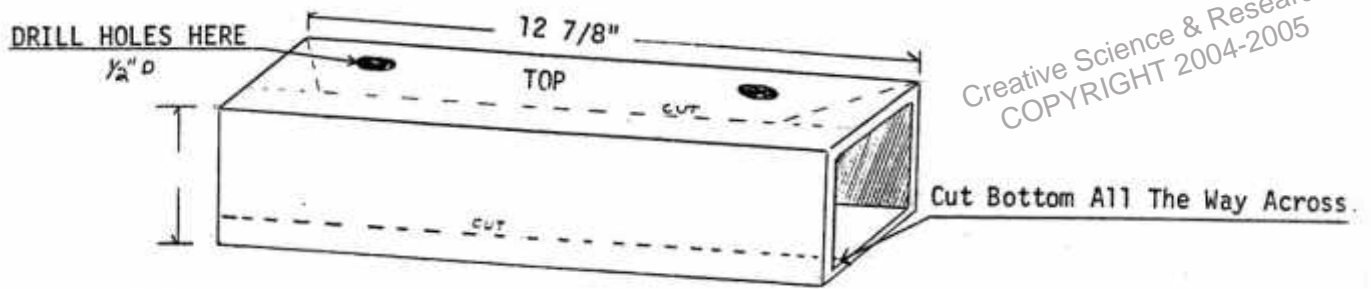

Creative Science & Research
COPYRIGHT 2004-2005

NOTE* Use measurments to cut by or you can have a metal shop bend it.

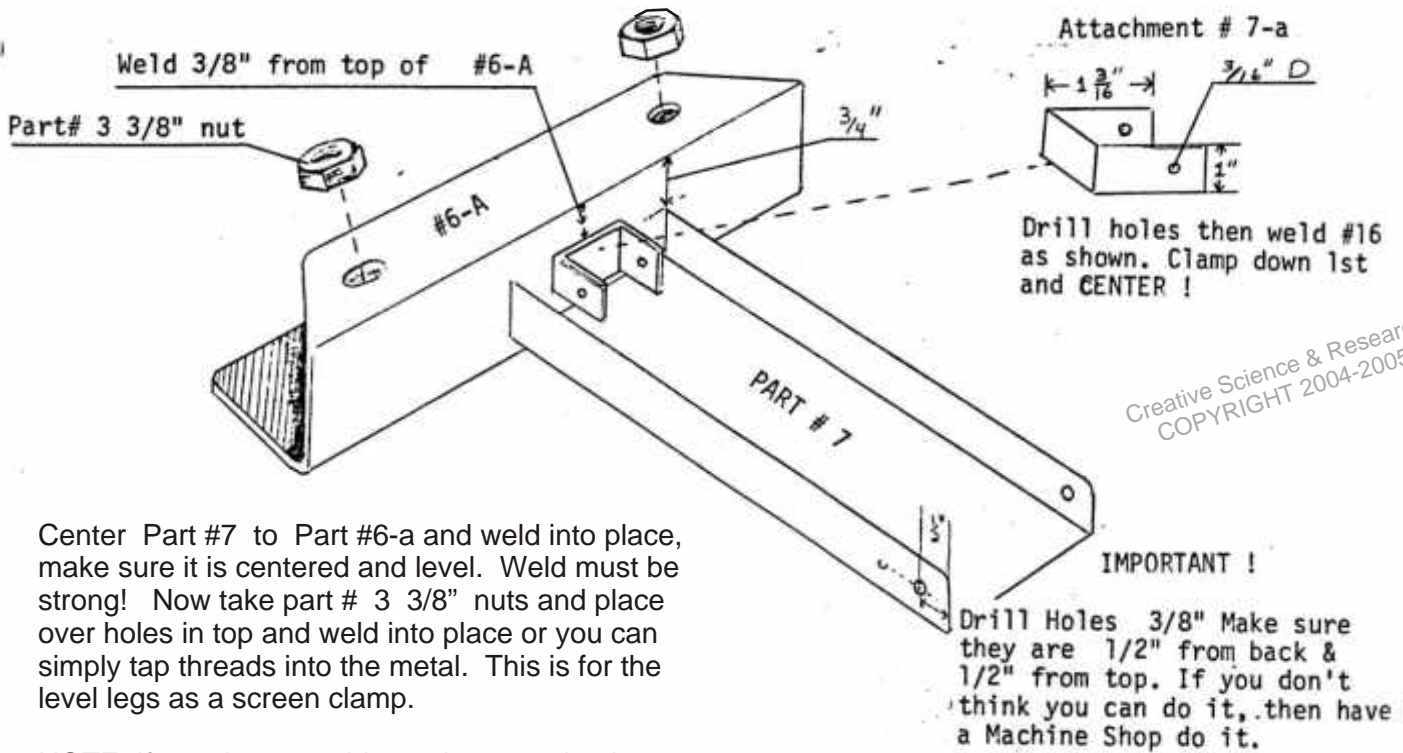

Creative Science & Research
COPYRIGHT 2004-2005

Center Part #7 to Part #6-a and weld into place, make sure it is centered and level. Weld must be strong! Now take part # 3 3/8" nuts and place over holes in top and weld into place or you can simply tap threads into the metal. This is for the level legs as a screen clamp.

NOTE: If you have trouble getting parts in place to weld use a wooden jig. See figure #Jig, it is very important that part #7 is welded level to part # 6-a

IMPORTANT !
Drill Holes 3/8" Make sure they are 1/2" from back & 1/2" from top. If you don't think you can do it, then have a Machine Shop do it.

Figure # Jig

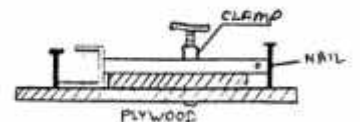



Spring Extension Arm Part # 25 You will need 5 of these

1. Get **part # 8**, Cut **A** to 4", With a 45° Angle. Weld **A** to **B** as shown. Then weld **C** to **A** as shown. Be sure to use a C clamp to position them. Sand down and file off rough edges.
2. Drill 2 1/4" holes Exactly 1/2" top and bottom & back.

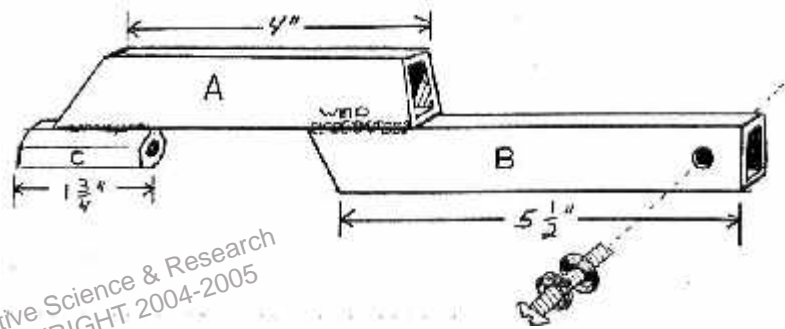

Creative Science & Research
COPYRIGHT 2004-2005

Take part #9 and cut off a total of 5 pieces, each piece being 7 1/2" long. Then with a hacksaw cut out D (see fig A) all the way through to the other side to the 6 " mark as shown. Now with a hammer pound C as flat as you can, then bend upward (see fig B, 3.) flat against the end of the cut. (see fig B, 4.) Then cut off the excess, rounding it with the tube. Be careful that you do not burn through the light metal. You can use thicker aluminum type pipe if you wish or gas pipe that is threaded on the ends and use threaded metal end caps. Drill 3/8" hole's in the ends of each pipe (see 5.) Now drill 2 3/16" bolt holes on the other end of the pipe. (see 6.) Make sure the hole are straight and centered. If you can not do it, then have a machine shop drill the holes for you.

The purpose of the Spring Arm is to allow the entire screen printing arm to move freely up and down. Into registration position and out of registration position. (See our Screen printing video.)

Spring and Bolt Assembly #7
Assemble part # 11-a and #10 to part # 11 bolt. Then slide into the Hydro Spring Tube Arm until the bolt comes all the way through (see Fig C) This bolt will later connect to the spring extension arm.
See Video Close ups.....# 402V \$19.95

Hydro Spring Arm #26

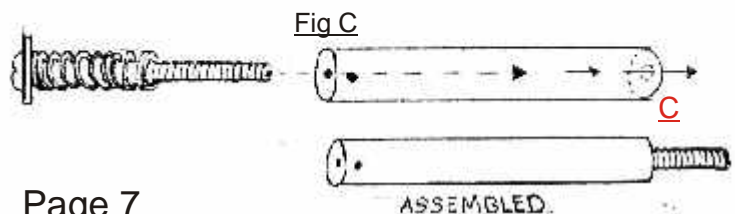
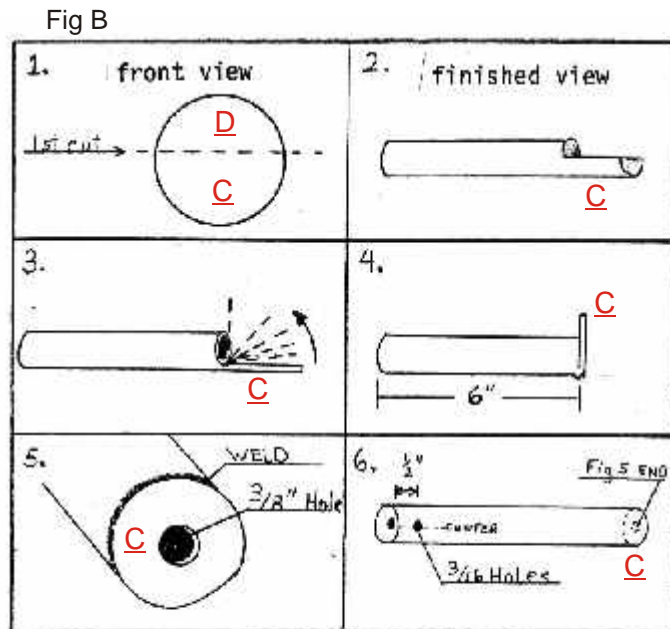
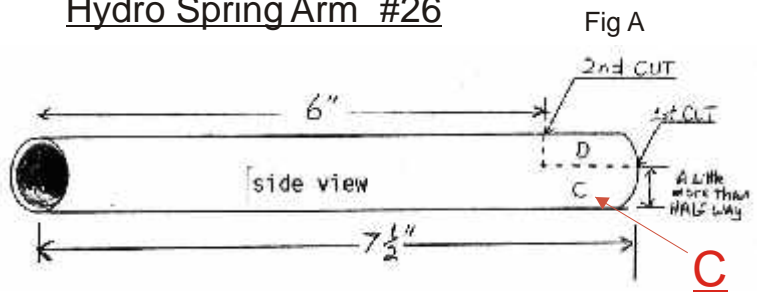

Registration Device

Part # 27 You will need 5 of these

Printer Registration holder is used for keeping the printing arm from moving while you are printing onto your T-shirts or solar cells etc.. (See Video)

Use part # 7-a and cut and weld as shown. Then drill a Qty of 2 - 3/8" hole on both sides as shown. Then drill 2 3/8" holes in # 24 as shown. (Placement does not need to be that close). Now assemble #24 to #27 using 2- 3/8" x 1" bolts, lock washer and nut.

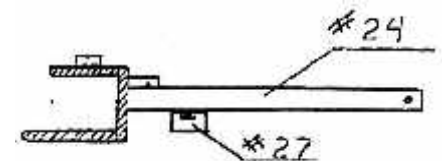
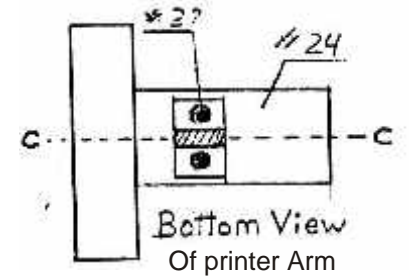
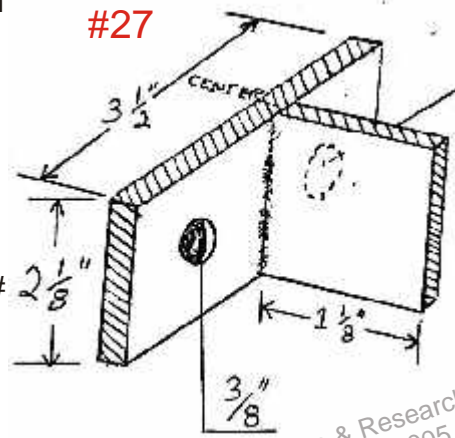

Side View of printer Arm



Hold Down Clamp Bolts (or Level Bolts)

(You will need a total of 10)

The screen printing screens fit into the #24 arms and are clamped into place so the screen will not move.

Use part # 3, # 4, & # 5 pad bolt and rod and weld as shown. Then attach to top holes of printing arm #24. Another option is to buy a pre-made level bolt and purchase a steel handle to attach to top of bolt. See Carrlane.com

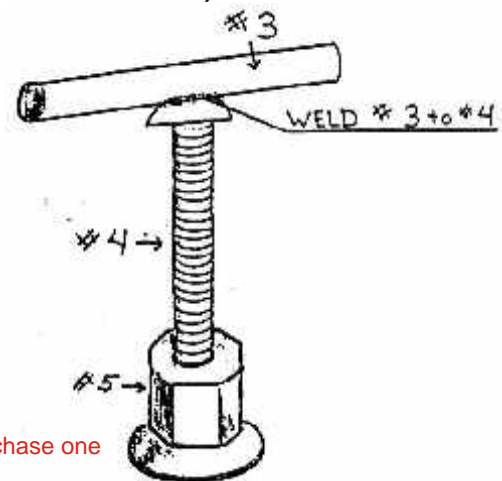
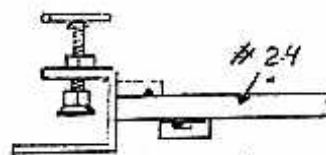

You can make your own or purchase one

Carousel #30 Lazy Susan

The Lazy Susan Carousel is used to turn the 5 arm printer around so you can print one color at a time with a **different** pattern. Use part # 18 & # 6 (the Lazy Susan) The lazy Susan will fit between **A** & **C** as shown. Cut 3- 19" diameter sheets of **particle** board or 1/2" cherry plywood for **A,C** and **D**.

A can be made of 1/4" thick metal. Nail and glue **C** and **D** #18 together. Now make center marks on **A** #18 and center, drill and attach **B** #6 (Lazy Susan to the bottom of **A**)

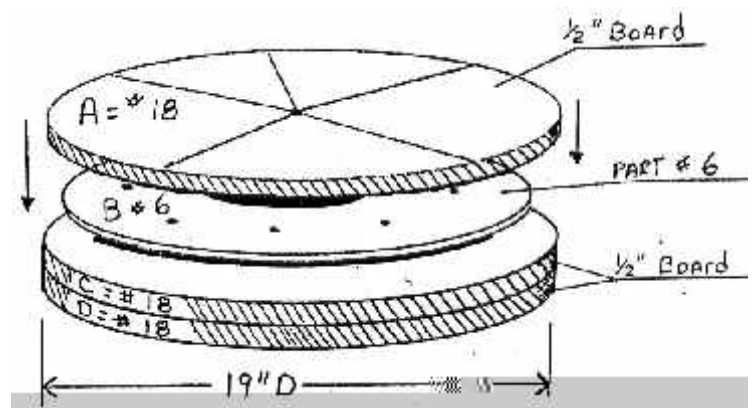

Rocker Arm Attachments

Part # 28 You will need 5 of these

You will need to bend these parts to the size shown or cut and weld. It is best to get a metal fabricator or machine shop to bend the 1/4" steel for you and then you can cut your angles out yourself. Once you have the U shape you will need to drill your holes. Drill holes **A** & **B** to 3/8" Diameter. It is very important that **A** is in perfect line to **B** so when you slide your 3/8" metal round rod into the hole the rod will be perfectly level. You can have a machine shop do it for you can do it yourself.

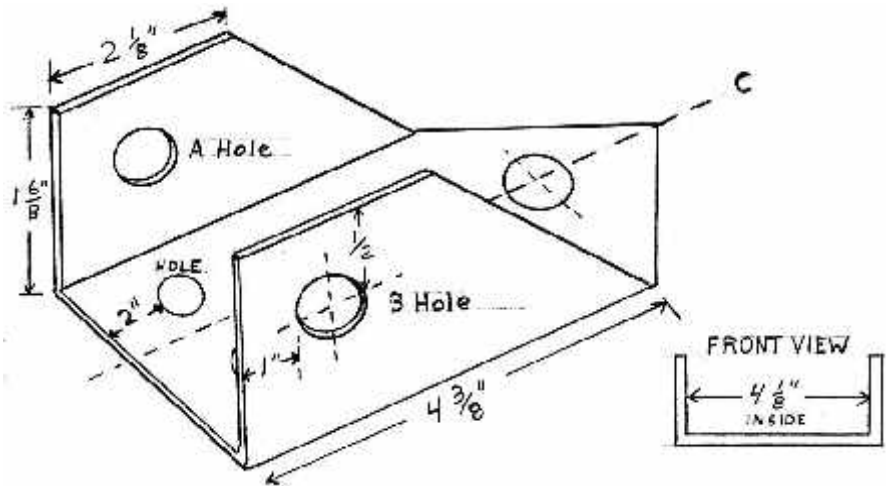

24 printing arm will be fitting inside here. So you will want about 1/4 space on each side. See Video...

Rocker Arm Attachments

Part # 29 You will need 5 of these

You must also have these bent to shape by a metal shop fabricator. Or again you can cut the metal your self and weld it. Cut and weld or bend to the size and shape as shown. Then drill your holes using a drill press and wood center inside of U shape for support. (When starting your holes always start out with a very small starter drill bit.) These attachments will attach and support the Spring extension arms. A short round rod shaft will be placed through the holes and Arm to attache them together. Use carter pins on the shaft ends.

*Creative Science & Research
COPYRIGHT 2004-2005*

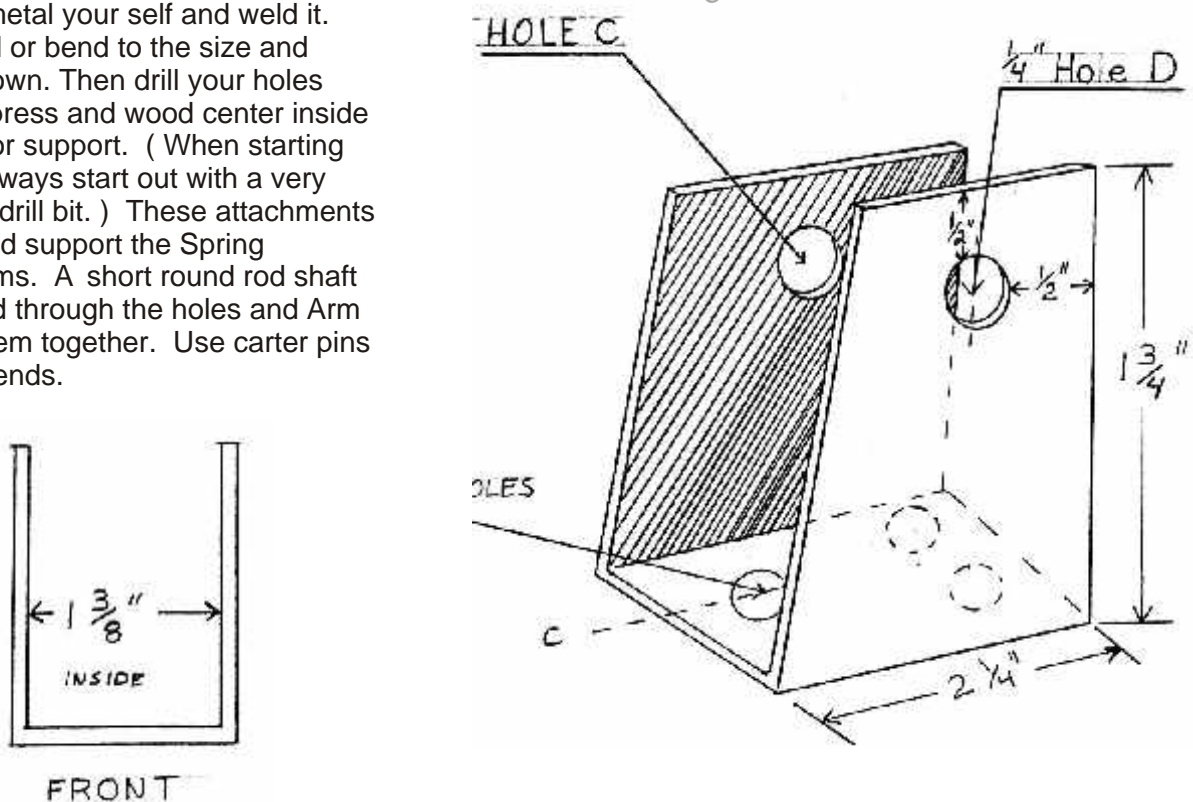

Rocker Arm Attachments Base

Carousel #30

This is a top view of the A=#18 Carousel assembly. It can be 1/4" thick metal or 3/4" cherry plywood. You will need to draw a center mark and a 5 line star. Now you will be attaching parts #28 and #29 to the metal carousel (which will have the lazy Susan attached underneath it.) Mark center lines on each part with a fine pint permanent marker or a fine point wax pencil. Now line up #28 & 29 parts and mark your drill holes with a pencil. Leave about a 1/2" space from edge to parts #28. Drill 3/4" holes so you can attach carousel #6.

If using 3/4 wood, After you drill your holes turn over your wood carousel drill larger holes over top of the smaller holes as a sinker, drill down about 1/2 way. This is so the nuts will be hidden. If you do not do this the nuts will drag when turning Carousel during operation.

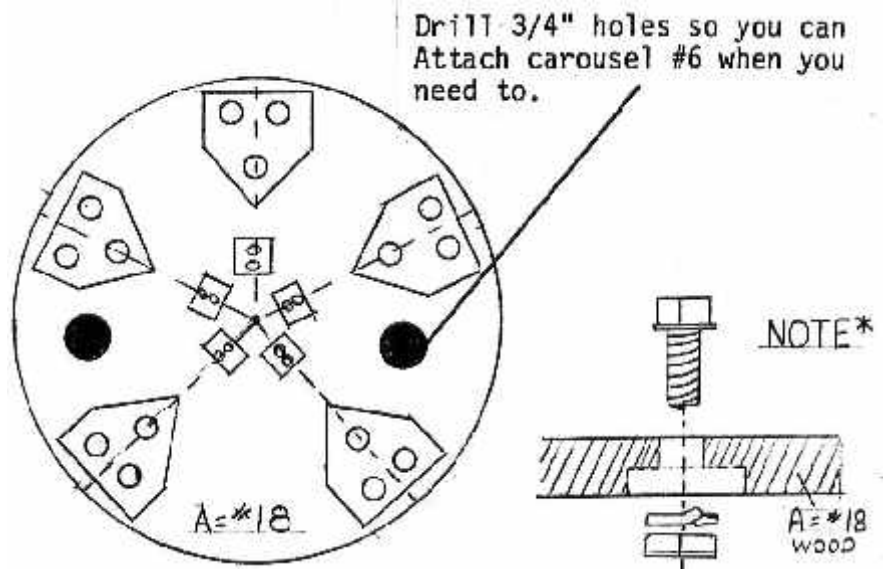

Fig 13

Creative Science & Research
COPYRIGHT 2004-2005



BASE #31

You can build a base unit for your carousel and arm assemblies to lay on or you can use a table top already made. It is best in the long run and much more convenient to build a base with rollers or you can purchase a metal heavy duty roll around cart from Graingers.com or another company from the internet.

Cut your plywood to the measurements shown in fig 14. Apply Elmer's Wood Glue before nailing each part together. Assemble entire cabinet and let dry 24 hrs. Then attach your heavy duty rollers on the bottom of the cabinet on each corner end.

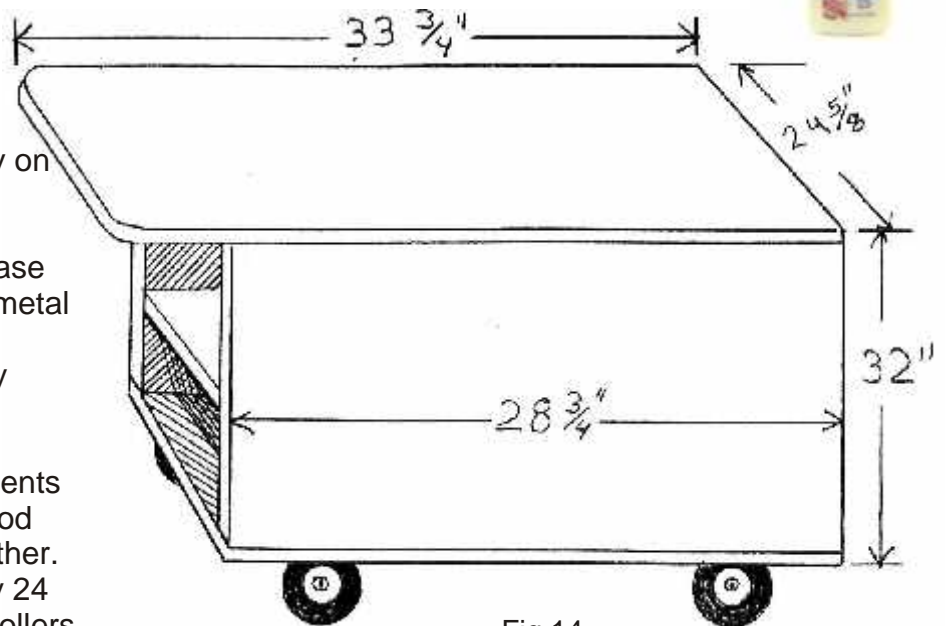
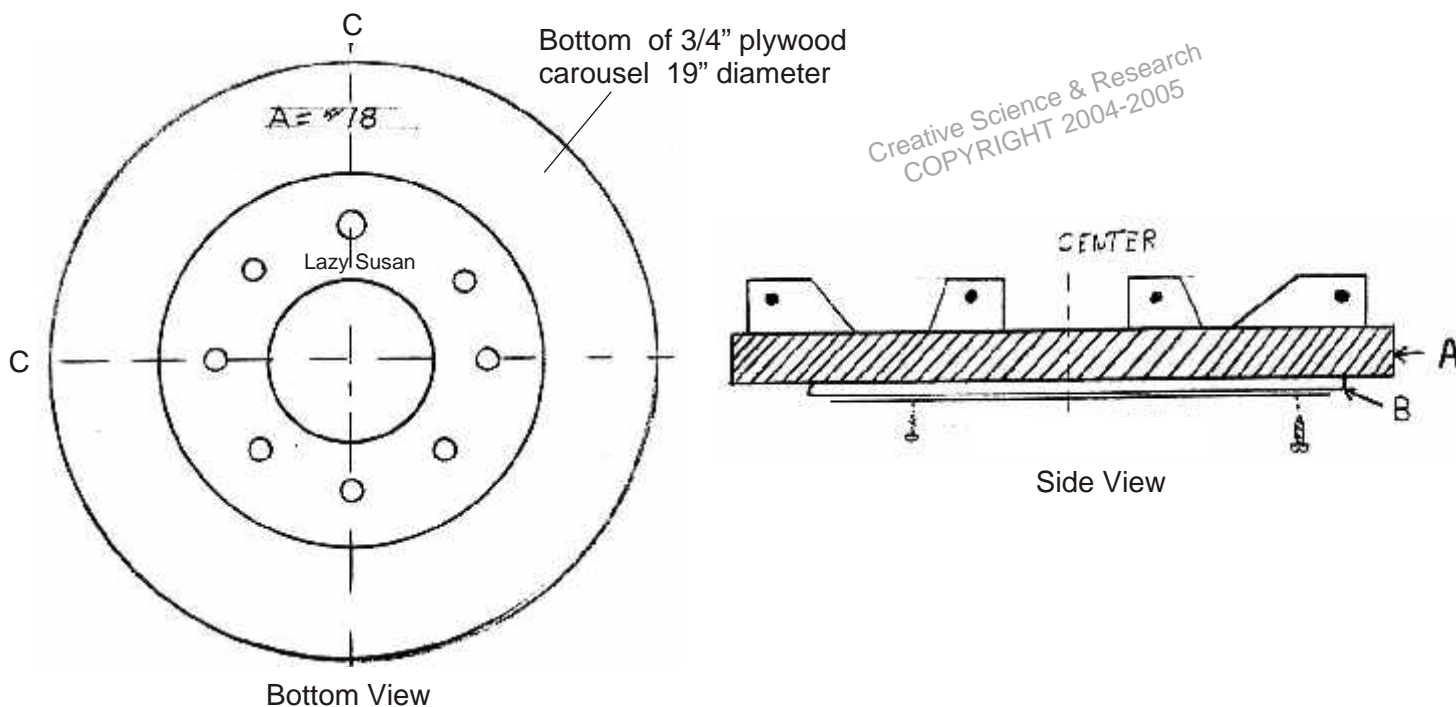

Fig 14

Attach Carousel to A=#18

Center part # 6 Lazy Susan onto the bottom of A = #18 3/4" wooden carousel (19" Diameter). Use wooden screws or nuts and bolts to attach Lazy Susan to wood. It is very important that the Lazy Susan is dead center of A= #18 or when printer is in operation the carousel could wobble.



Creative Science & Research
COPYRIGHT 2004-2005

C= #18 and D = #18 1/2 particle board or plywood 19" diameter pieces should have been glued together with Elmer's glue. (see page 8) You must now attach these to the top of the back of the base unit with long bolts or wood from underneath the top of table base unit. (be sure to use Elmers glue on this as well) Now center the Carousel and Lazy Susan assembly over top of the 19" diameter wood pieces and attach using wood screws or other, using a starter drill bit smaller than the wood and screwing in wood screws or use an electric screw driver.

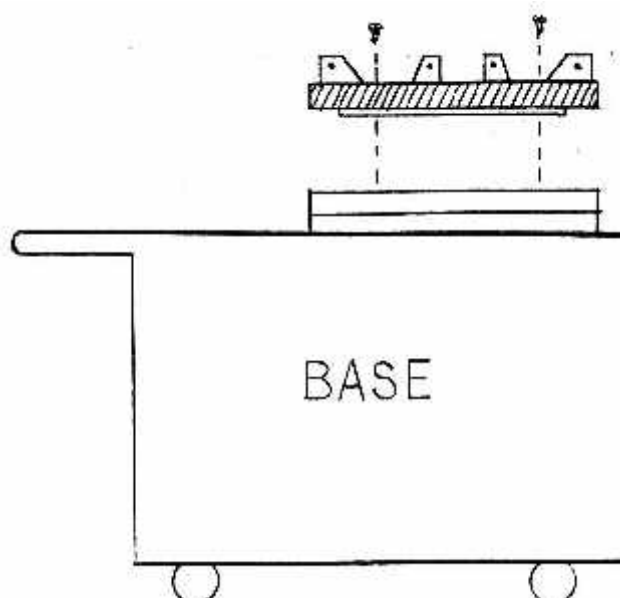

Roller Bearing Registration Sysytem

Part # 31

Part # 31 (see page 1)
 Use a 4" piece of angle iron. Drill your holes as shown. This part must be as accurate as possible. (Get a machine shop to drill long holes for you if you can not). Now attach your roller bearings (part(s) # 17). Use 3/8" short bolts.

Do not tighten bolts and nuts yet until you assemble entire printing press. This should be the last thing you do. This part is for registering the printing arms to the printing pallet. The printing pallet is where you lay the object you want to print. The printing arm comes down and the part #27 that is attached to the printing arm(s) fits in between the 2 roller bearings.

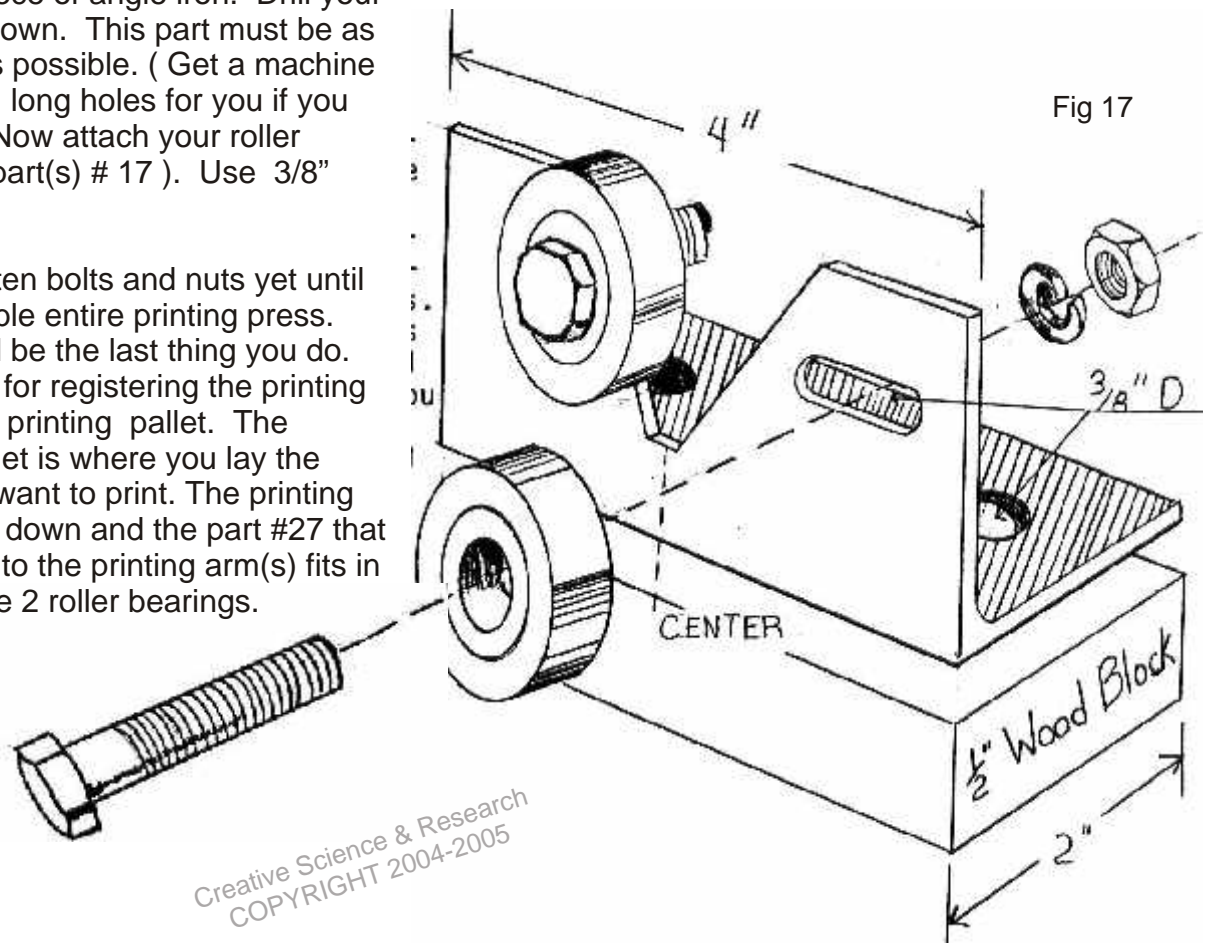

Printing Pallet #32

This is the printing pallet (see page 1 & 2 also) If you are printing T-shirts, solar cells or paper signs, 3-M Spray Adhesive is applied to the top and allowed to dry for 4 to 5 minutes and then object to print is placed on the pallet and screen printed. (see Video \$19.95 order # 402Video) Pallet base arm is part # 7 (metal) or a hard cherry wood can be used. Cut long bolt holes so pallet can be adjusted as needed during registration process. Pallet and pallet base are then attached to printing base # 31 (See page 10)

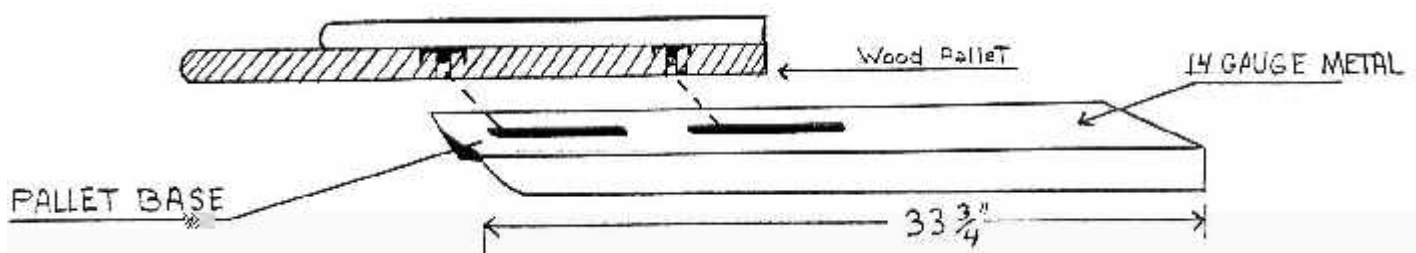

Printing Pallet cont....

Use 1/2" particle board #18 & #21.
You will also need to wood grip nuts or t-nuts as they are called, 3/8".

Drill 3/8" holes in **A**. Hammer in wood grip nuts in top of the 3/8" holes, pencil 2 center marks one on **A** and one on **B**.

Notice: before putting together, you may need to drill out or router out a space for the nuts to fit snug with top board. Now apply wood glue and nail **A** to **B** make sure everything is straight!

Let dry 24 hrs and sand all edges to a smooth touch.

(see page 1 - part # 32)

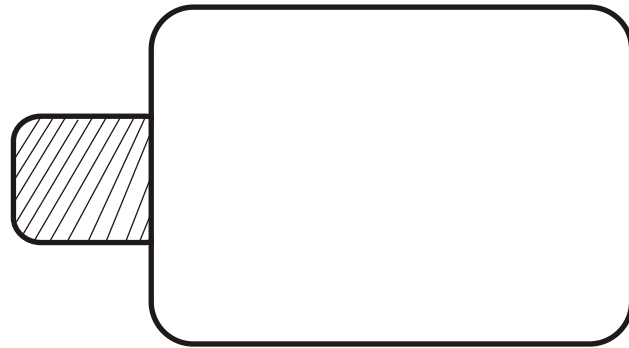

Top View

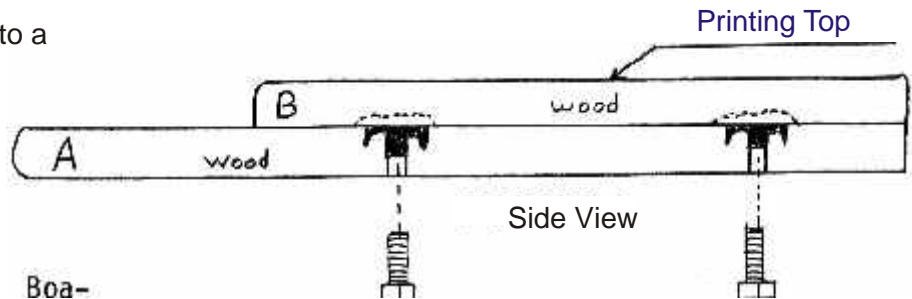

Side View

T-shirt Suppliers Wholesale:

www.Cheapestees.com

www.Blankshirts.com

Creative Science & Research
COPYRIGHT 2004-2005

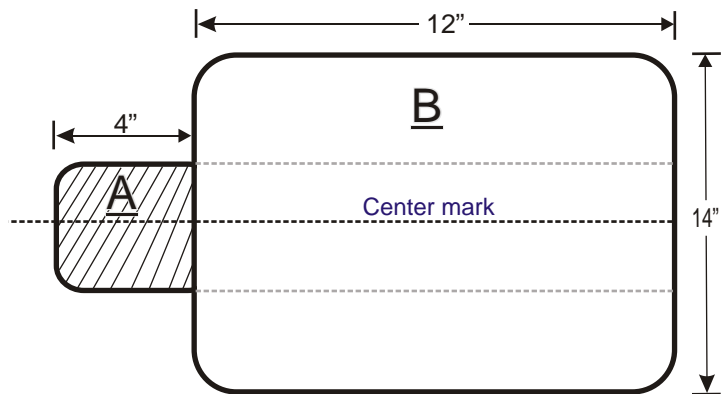

Top View

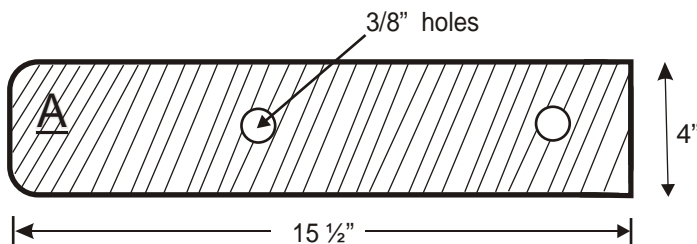

ASSEMBLY: Make sure all parts are sanded and painted very well! Attach printing pallet assembly to cabinet base using bolts. The extension arm can be ½" cherry wood, do not use particle board. Center the printing pallet onto the base, drill 2 holes on the end of pallet extension arm and the wood cabinet base and use ½" nuts and bolts to attach. The printing pallet can have a Formica top or wood top. Formica is best. Many lumber yards and some hardware stores carry small Formica counter top pieces which you can purchase and cut to Printing Pallet size. All metal parts should be painted with a primer first and then 3 coats of a good industrial blue / green color should be used. Now attach the metal printing arms and spring extensions to the carousel. Attach # 26 spring extension to # 6-A. It is best to attach #29 and #28 to the wood or metal carousel using 3/8" nuts and bolts.

For #29 you can use 3/8" bolts or 3/8" round rod with carter pins on both sides, (round rods are best to use in the long run.) Once you are done attaching everything you can now adjust your spring extension arms using a pair of pliers. Flip a printing arm up and turn the bolt to tighten the spring until the arm will stay up on it's own. Do this to all 5 printing arms. Now adjust your roller bearing register guides (#27 and #31) #27 should fit snug in between the 2 roller bearings. If you built every arm to the exact same measurements and all is centered and straight each arm will now be able to lock into the #31 roller bearing register guide when you swing an arm around pull it down by hand into the guide, there should not be any play in it at all. Now pull arm up and out and swing to the next arm. If an arm is giving you trouble and not staying in the up position when you are not using it then re adjust the spring tension.

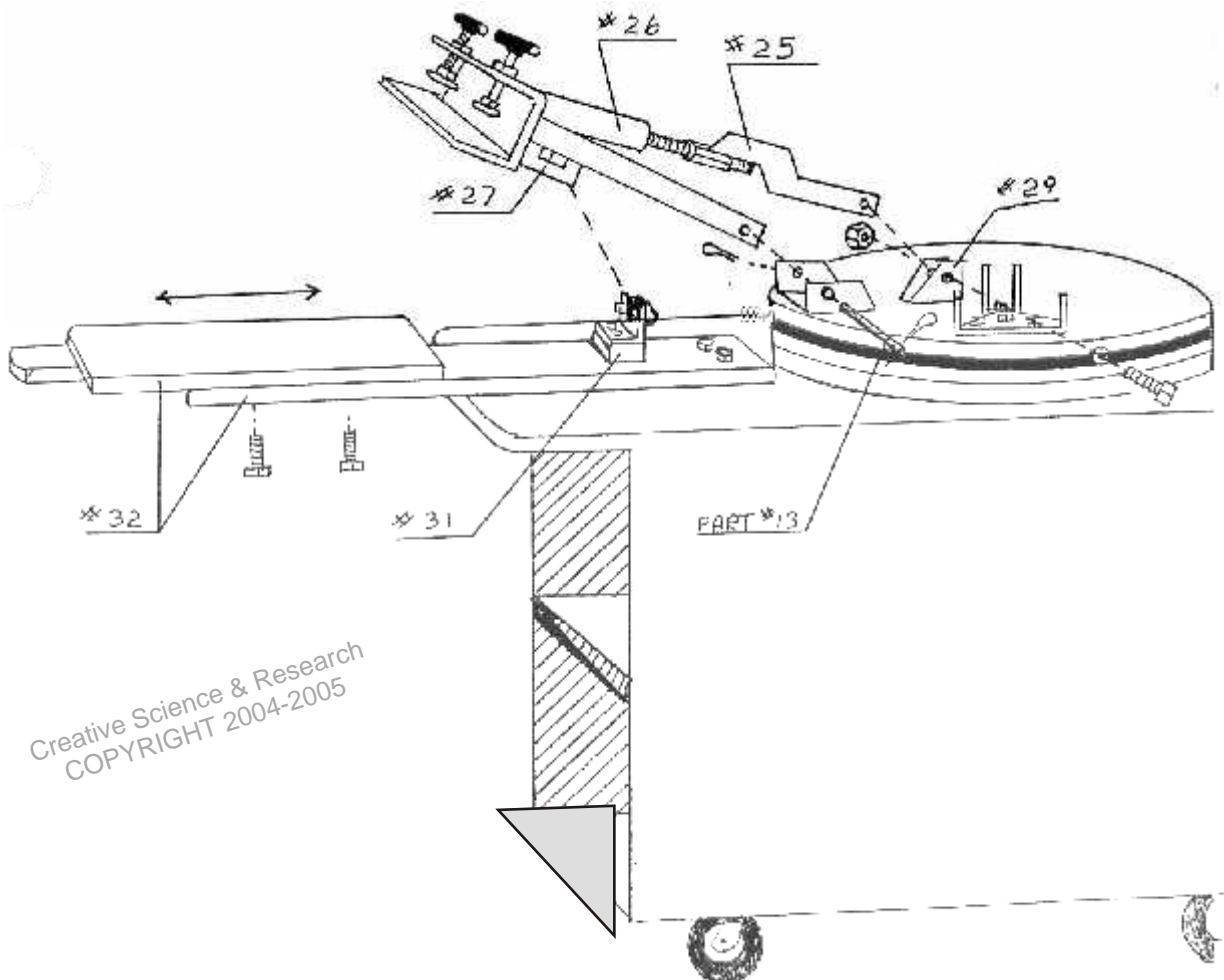

Creative Science & Research
COPYRIGHT 2004-2005

Screen Printing

We hope you enjoy this information. All this information can be applied to screen printing Solar Cells on glass, plastic or metal. If you are needing more information as in large booklet forms as well as Screen Printing supplies, then check out these companies online at: www.silkscreenbiz.com another great supplier to check out is at: www.ryanrсс.com

The following photo's are just examples of what is used to Screen Print.



2 wood frame printing screens



Example: of 3 aluminum frames



1 color t-shirt printer, which can be used to print Solar Cells



6- Color T-shirt Printer

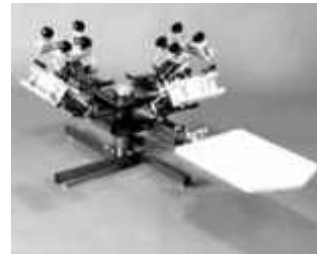

4-Color T-shirt Printer

Screen Printing

Materials you will need

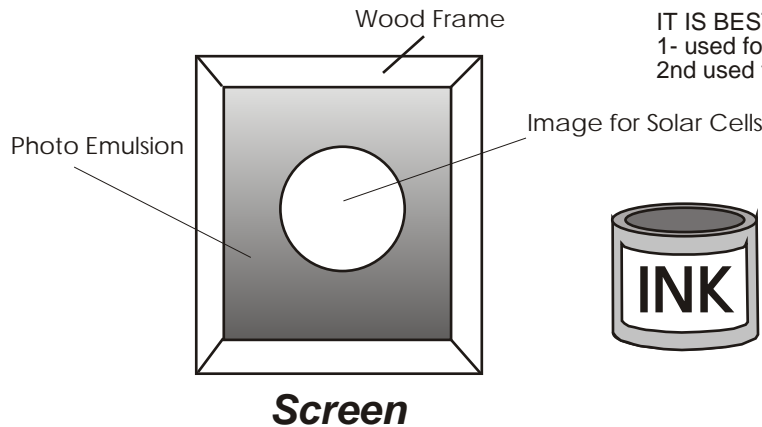

IT IS BEST IF YOU MAKE OR BUY 2 SCREENS
1- used for negative contact, nickel mesh print
2nd used for layers n-type and p-type.

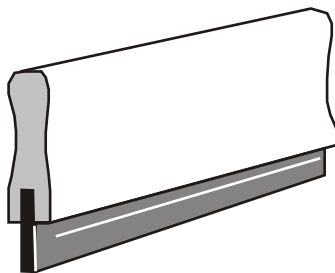

Squeegee

Used to move the printing ink from the top of the inside of the screen to the bottom. To press the ink through the image and screen onto the glass or paper.

1. SPRAY ADHESIVE
2. RAGS-Viva PAPER TOWELS for clean up.
3. MINERAL SPIRITS
4. LACQUER THINNER
5. SMALL DOOR HINGES
6. A TABLE TO PRINT ON
7. PHOTO EMULSION or LACQUER FILM
8. RUBYLITHE or AMBERLITH FILM
9. EXACTO KNIFE
10. Screen Coater 13 1/2"

Screen Printing

Homemade Solar Cells

Learn how to build your own 16 " Solar Cell, and you can do it right in your own back yard! **Information the Solar Cell Companies do not want you to know!** Just by using the art of screen printing and your outdoor grill to bake them, you can make as many powerful solar cells as you want!

Cover your entire roof! We were told these cells are just as powerful as the US made Silicon cells.

Plans/ Patent only..... **\$16.95** #401

Screen Printing Video only..... **\$19.95** #402Video

Screen Printing Booklet only.....**\$9.95** #402booklet



Output: 12 VDC
by 8 amps
16" Diameter

Example only!

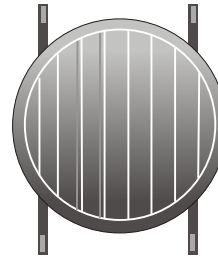

Plans Only
\$16.95
401

Creative Science & Research
COPYRIGHT 2004-2005



Learn how to Screen Print.

Screen printing is done all over the world by very large printing companies right down to the guy who does it at home in his basement. Screen printing was first discovered by the Chinese hundreds of years ago. It is a very simple process that anyone can do. The Chinese first used silk to use in there wood frames to print with, then as time went on better material was made to print with.

With your new 5 color printing you can print up to 5 colors on t-shirts, wet on wet and then if using platisol ink you will need to heat cure with an infra red dryer. Suppliers also sell air dry ink but you can only print one color onto a shirt with that.

www.Silkscreenbiz.com
www.ryanrss.com or signindustry.com

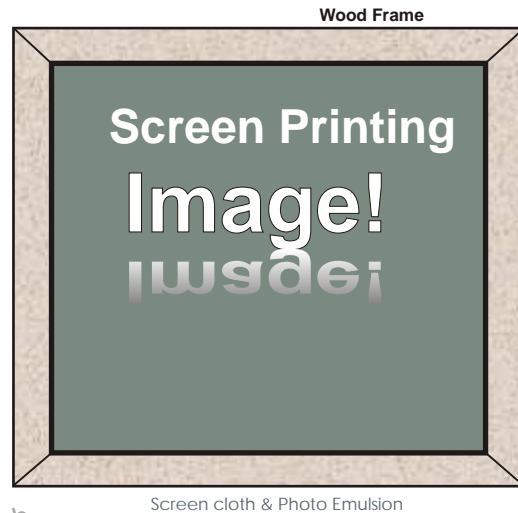

*Creative Science & Research
COPYRIGHT 2004-2005*

Screen printing is done by using a wooden frame with screen printing cloth stretched over it, Then there is a photo emulsion applied to the screen, dried and then exposed to a bright light source, (You can use the sun or a photo bulb)

but before exposing it to the light source, you must first apply your film positive to the back of screen. A film positive is simply a clear piece of plastic with a silhouette or a profile or art work design filled in with a dark color, in this case you can use dark red or black. Art stores and screen supply companies sell a red film you can cut with an exacto knife called amberlith. You simply cut out your design and peel away the background that you do not want. I suggest you go to a local screen printing shop and ask them if you can buy a small 24" x 24" piece, it would be cheaper than buying a whole roll. Once you are done cutting out your design on the amberlith plastic film, you then spray the front of it (the side with the film cut on it,) with all purpose spray adhesive, let it dry for 3 minutes or so and then apply to back of Photo emulsioned screen and then expose to light source.

Now after exposing it to the sun, the screen is then washed out with water using a water hose. The black or red image on the film positive did not let any sun get to the photo emulsion, therefore the unexposed photo emulsion can then be washed out, the other has been hardened by the sun light and can not be washed out. now after the screen has dried. you can use it to print your image with over and over as many times as you like.

Ink is then applied to the inside of the screen, and by using a soft rubber squeegee, you pull the ink over top of the image area. ink then only passes through that area which was not exposed to the sun. (See our video) This process is known as screen printing.

Let me give an example: The screen is like an open water valve, when certain areas of the screen are stopped off, then the water can not go through it, only where you want it to go.

The photo emulsion can be like this example: take a 8 ½" x 11" piece of paper. now cut a hole in it. now lay it flat down onto a table. Now get a can of spray paint and begin spraying the paper. Now lift the paper up and what do you have? you have a painted circle. This is the same way screen printing works. The nice thing about screen printing is you can pass just about any type of liquid you want through the screen print area. If you are printing on paper you can screen print with any type of paint or screen printing ink, just as long as it is thick enough. If it is to thin your printed image will have run spots.

Creative Science & Research
COPYRIGHT 2004-2005

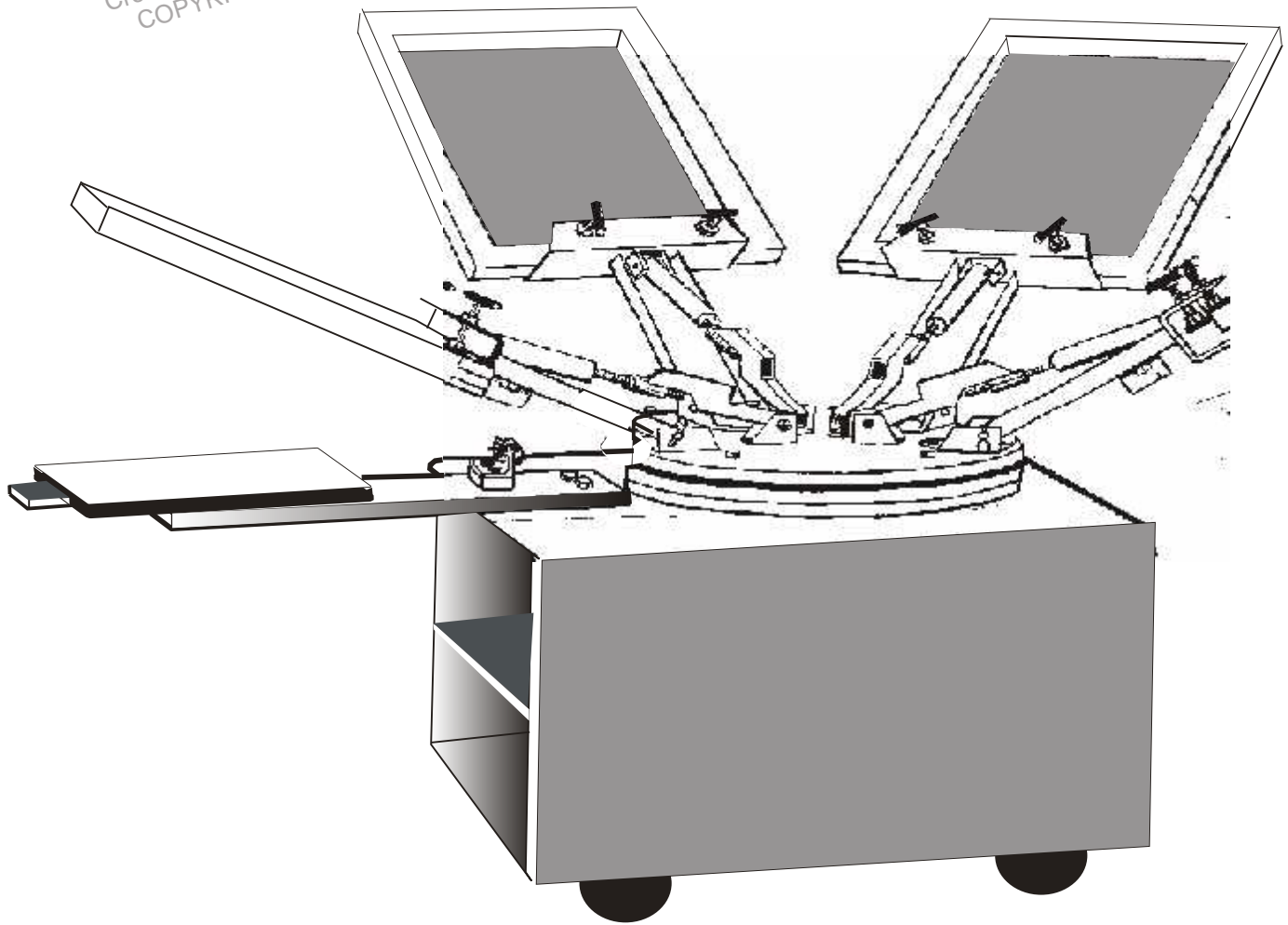
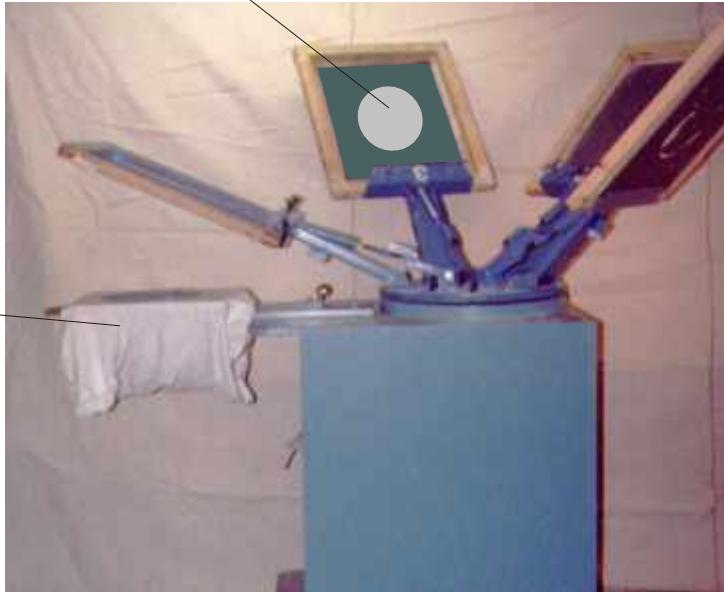

Photo Screen Emulsion

Creative Science & Research
COPYRIGHT 2004-2005

Example: 4" diameter Solar Cell Image in photo screen

Replace T-shirt
with Glass or other
and print solar cells



JCM1 5 -Color Screen Printing Machine
Constructed By: David Waggoner 1991

