

# Tropical animal feeding

A manual for  
research workers



Food  
and  
Agriculture  
Organization  
of  
the  
United  
Nations



## Foreword

This is the second edition of the manual written by Dr T.R. Preston and published by FAO in 1986, as Animal Production and Health Paper No 50/2: " Better utilization of crop residues and by-products in animal feeding: research guidelines. 2.: A practical manual for research workers" FAO, Rome, 154 pages. This manual has proven to be a very useful tool for research workers in developing countries and has been in great demand since its publication. After 9 years, it was necessary to update it taking into account the large experience gained in the meantime and the changes which have occurred during this period of time in the developing countries.

In fact, this manual has been completely rewritten and greatly extended. The new version contains twice the number of pages compared to the first one. Its scope is no longer limited to crop residues and by-products, but considers also other feeds. More attention has also been given to monogastric animals, because "modern" feeding systems imported from developed countries have in many countries led to the import of feeds, thus increasing the external debt of developing countries. Imports of feed by developing countries represent several billion dollars a year! The multipurpose role of livestock as a provider of food, but also of income, energy, fertilizer and its implications on feeding systems are considered. Environmental issues linked to livestock production systems are also taken into account. In this context, research constitutes a **big challenge** for animal nutrition scientists in developing countries: to promote feeding sustainable systems which make greater and better use of local resources for the benefit of small farmers.

The manual is not a list of recipes for making laboratory analyses or preparing experiments. Half of its contents is devoted to describing the essential principles which should assist the research worker in conducting useful and cost effective research. This includes: the importance of managing natural resources for sustainable development and of identifying priority areas for research aimed at solving practical problems and improving the lot of small farmers in developing countries, the basic principles of animal nutrition, the identification of important feed resources and of some appropriate technologies to better use them..

The contribution of various scientists who have accepted to review the first draft and made valuable comments and suggestions is acknowledged. Special mention is due to: M. Chenost and his colleagues (National Agricultural Institute, France), F. Dolberg (University of Aarhus, Denmark), B. Gohl (FAO Regional Project, Botswana), N.M. Jayasuryia (IAEA, Vienna), C. Kayouli (National Institute of Agronomy, Tunisia), R.A. Leng (University of Armidale, NSW, Australia), E.R. Ørskov and his colleagues (Rowett Research Institute, U.K.), Rena Perez (Ministry of Sugar Production, Cuba), R. Sansoucy and his colleagues of the Feed Resources Group (FAO, Rome), A.W. Speedy (Oxford University, U.K.) and M. Wanapat (Khon Kaen University, Thailand).

The final editing of this publication was undertaken by Andrew Speedy, Department of Plant Sciences, University of Oxford, England, and René Sansoucy, FAO, Rome, and formatting by A.W. Speedy.

---

# Contents

<b>Chapter</b>	<b>Page</b>
Foreword	iii
<b>1 Managing natural resources for sustainable livestock-based agriculture</b>	<b>1</b>
<b>2 Identifying priority areas for research on tropical feed resources</b>	<b>21</b>
<b>3 Nutrition of non-ruminants</b>	<b>35</b>
<b>4 Feed resources for non-ruminants</b>	<b>51</b>
<b>5 Nutrition of ruminants</b>	<b>83</b>
<b>6 Feed resources for ruminants</b>	<b>109</b>
<b>7 Technologies for improving the use of renewable natural resources</b>	<b>135</b>
<b>8 Design and analysis of experiments</b>	<b>155</b>

<b>Chapter</b>	<b>Page</b>
9 <b>Biological and chemical analytical methods</b>	181
10 <b>Animal feeding trials</b>	241
11 <b>On-farm research: a discussion of some practical examples and procedures</b>	253
12 <b>Guidelines for the evaluation of feed resources</b>	265
13 <b>Presentation of research results</b>	277
References	283

# Foreword

(This should be written in Tms Roman 11 Pt with Helvetica 9.6 Pt headings).

Final editing and formatting of this publication was undertaken by A.W. Speedy, Department of Plant Sciences, University of Oxford,

England.

Chapter 1

# Managing natural resources for sustainable livestock-based agriculture

*The aim of this chapter is to provide guidance to researchers as to the topics which should, or should NOT, be researched, if there is to be a firm commitment to promoting the sustainable use of natural renewable resources. For further discussions on some of these issues the readers are referred to the books by Preston and Murgueitio (1992) and Ørskov (1993).*

*The issues discussed in this chapter provide a conceptual basis for the sustainable use of renewable natural resources in livestock-based farming systems for the tropics. The interpretation of this strategy in the form of practical farming systems has profound implications both for the type of feed resources that will be on offer, the species of livestock most suitable for their utilization, the most appropriate way to evaluate them and the manner in which such feeds should be incorporated into the diet of the animal. These themes are the basis of research into the better use of tropical feed resources for livestock and will be dealt with in detail in the remaining chapters.*

## **THE ROLE OF LIVESTOCK IN RURAL DEVELOPMENT**

Livestock production (i.e., all aspects of production systems, their products and by-products) in tropical countries of the less-developed world, has been and must continue to be one of the most important economic and social activities of human culture. In these regions of the world, hundreds of millions of people depend directly or indirectly on livestock-based activities, the analysis of which is complex and multi-sectorial.



Many technical and economic endeavours, at national and international levels, have attempted to increase animal production and animal productivity in the tropics but results in general have been meagre. Of the many explanations of this phenomenon, perhaps the most pertinent is the lack of understanding of the ecological, socio-economic and cultural limitations inherent in these countries which constrain severely the application of conventional development models.

Paradoxically, there are also incredible opportunities for sustainable development, thanks to the enormous cultural and biological riches of the tropics, the rational exploitation of which could support sustainable production in the medium and long term, but which have not been considered seriously in previous attempts to develop the livestock sector in these regions.

The role of livestock in developing countries is quite complex and extends beyond their traditional uses to supply meat and milk as is invariably the case in the industrialized countries (Sansoucy, 1994). They are certainly multi-purpose. They are valued for one or several (sometimes all) of the following traits: capital, credit, traction, milk, meat, hides, fuel and fertilizer. Thus, for families without land, livestock are primarily a means of increasing the family income. For the crop farmer especially in Asia, but increasingly in Africa and Latin America, the large livestock - cattle and buffaloes - are primarily sources of traction and power. In many societies the dung is used for fuel and to a lesser extent as fertilizer. For the transhumant grazier, livestock may be most valuable as a capital resource and a source of credit. Production systems must take into account these varied roles, and must be adapted to specific local situations.

If, as expected, fossil fuel prices increase in the long term at rates exceeding average inflation in the industrialized countries, then one increasing role will be the use of livestock as sources of power in agriculture. This is already the case for many countries in Asia with low GNP and low international purchasing power (e.g., Bangladesh and Vietnam).

The other issue, which perhaps relates more specifically to Latin America and parts of Africa, is that the principal livestock production system is extensive grazing by large ruminants, the establishment of which has mostly been through the destruction of the natural ecosystems

of the tropical rain and cloud forests. These systems have consolidated the position of the medium to large landowner/cattle rancher and, by so doing, minimized opportunities for the small-scale farmer.

Despite the privileged role accorded to extensive cattle ranching - witness the supporting research and development efforts over more than three decades by both international and national institutions - these production systems have become increasingly less profitable, due to increased prices of animals, feeds and other inputs, as well as increasing land prices due to competition with other end use patterns. The result has been their conversion into secondary activities kept in place by support (subsidies) from industry and commerce.

Livestock are enormously important to the economies of the less-developed countries as a whole. According to Brumby (1987), when the value of livestock in providing rural transportation, draught power for cultivation, manure for crop production and their ability to utilize non-arable land and the agricultural residues are added to the direct economic value of animal products, livestock accounts for about half the total agricultural production. Livestock also play a critical role in maintaining a cash flow for poor farmers who grow their crops essentially to provide food for their own household. Milk, meat and hides will always be sought after by those segments of society that have the necessary purchasing power to acquire these products. To the farmer-producer these products represent opportunities for generating income.

### **ECONOMIC GROWTH AND RENEWABLE NATURAL RESOURCES**

It is becoming a matter of increasing concern (Daly, 1993) that the present rate of economic growth is already outstripping the capacity of the earth's ecosystems: (i) to produce the required resources; and (ii) to absorb the pollution caused by present levels of economic activities. The impact of the expected doubling of the human population by the mid-term of the next century, most of which will take place in developing countries, coupled with the aspirations of the present and future under-privileged majority, poses a threat that can in no way be described or predicted.

It is quite clear that future scenarios of resource utilization must be predicated on:

- Optimizing the capacity of the earth's ecosystems to produce biomass, as the only renewable source of energy, chemicals and food, without compromising the biological diversity on which the survival of all ecosystems depends.
- Minimizing waste through recycling, which reduces the need for raw materials and helps to protect the environment.

For livestock to play a symbiotic role in such a scenario, it will be necessary to give priority to species that combine efficiency of conversion and productivity, produce low emissions of methane (a major "greenhouse" gas), and have the capacity to use by-products and residues from other primary industries.

Pigs and scavenging poultry undoubtedly are the preferred animal species in this scenario, but there will be an increasing role for the small, as opposed to large, ruminants and for the small non-ruminant herbivores (Cardozo, 1994). High reproductive rate is what gives the competitive edge to these species. Aquatic systems with multiple production of fish, ducks, geese, water plants and other animal and plant species will also find an increasingly important niche in the new livestock development model. The large herbivores will have a primary role as sources of power and fertilizer for agriculture, which they will achieve by recycling the residues from the crops they help to produce. Increasingly they will be expected to combine these activities with milk production and reproduction. The use of castrated males for work is a luxury which future pressures on resources will make increasingly less attractive. As with the plant kingdom, the need for biodiversity *per se* will justify the domestic use of the widest possible range of livestock species.

Among the largely unexplored possibilities of the diverse animal species present in tropical ecosystems, the natural wildlife - mammals, birds, reptiles, fish and crustaceans - can also make a contribution to sustainable livestock production systems, especially because of their adaptation to the ecologically fragile zones and their contribution to biodiversity (Cardozo, 1994).

**SUSTAINABLE USE OF NATURAL RENEWABLE RESOURCES**

The World Commission on Environment and Development (Brundtland Report, 1987) defined sustainability as "ensuring that development meets the needs of the present without compromising the ability of future generations to meet their own needs". To this can be added the need to respond to the pressures increasingly coming to bear in both industrialized and developing countries to safeguard natural resources (see Brown *et al.*, 1991). In livestock-based agriculture, production systems must take into account these issues. In practical terms this means measuring the "sustainability" of the system according to its effects on:

- the economy,
- the environment,
- the need for energy (especially from fossil reserves),
- animal welfare, and
- food quality and security.

**Economic constraints**

The prerequisite of any livestock system is that it should be profitable to the producer. In all industrialized countries, the costs of livestock production have escalated mainly because of the increase in the cost of labour caused by rising expectations (standard of living) and competition from other industries. The situation is exacerbated in those countries where farm size is small and therefore unit costs of mechanization are high. Faced with such situations, governments have resorted to subsidizing agriculture through guaranteed support prices and other forms of financial assistance. The total cost of this support amounts to a staggering 75% of the total value of agricultural production in Japan, 40-50% in the European Economic Community and up to 25% in the USA.

Producers are supported in industrialized countries through subsidies and protected markets. These supports have two important consequences: (i) they increase the price of food to the domestic consumer; and (ii) they reduce the economic growth of many developing countries unable to export primary and secondary commodities against the barriers of tariffs and quotas.

Such policies in the long term are not sustainable. They are inefficient in resource utilization since they direct expensive resources

(often produced with cheap fossil fuel) into products which could be produced elsewhere with fewer resources. The production of wheat and milk in some oil-rich countries, which is only made feasible with massive inputs derived from fossil fuel (in fertilizers, irrigation and machinery) is an example of this misguided policy.

For the world economy to grow at an optimum and more equitable rate, it is essential that there is free trade in basic commodities. The objective of GATT (General Agreement on Trade and Tariffs) is precisely to promote the concept of "comparative advantage", whereby commodities are produced in the areas/countries which use least resources for that purpose. Unfortunately, the free movement of capital means that the principal beneficiaries from the exploitation of "comparative advantage" are likely to be the large multi-national companies. An even more worrying issue is that comparative advantage can also mean advantage gained by not paying the environmental cost of a given production activity.

Another world trend likely to have considerable economic impact is the future cutback in the availability of cereal grains for livestock feed. Two factors will contribute to this trend. On the one hand, the rising human population in low income countries will increase the demand for cereal grain which usually is the cheapest staple either to produce locally or to import from world markets. On the other, state subsidies and protection, although still at high levels in the industrialized countries, will gradually be reduced as a result of the GATT agreement. Grain prices will rise as a consequence. Increasing cost of agro-chemicals and fossil fuel, and environmental pressures, will lead to cutbacks in the use of these inputs which in turn will lead to lower crop yields and increased costs of production.

For the poor small scale farmer in a less-developed country where subsidies on the scale presently employed by the industrialized countries are out of the question, the priorities are food security and to maintain their life style (e.g., as with pastoralists and indigenous peoples). The essential steps to achieve this are to produce first for family consumption, using an integrated production system involving crops, forestry and livestock, and which ensures self-reliance by making maximum use of renewable natural resources with minimal dependence on inputs from outside.

This is a more economical and ecological way of improving their standard of living, as compared with the developed country models which have used fossil fuel to achieve this end.

## **ENVIRONMENTAL ISSUES**

The productivity and efficiency of livestock production per animal unit in the least-developed countries is considerably less than in the more-developed world. But 'productivity' and 'efficiency' are references that relate specifically to temperate agricultural practices. In the tropics, livestock activities are different - how does one measure the efficiency of survival, or as a credit institution? These and other productive traits are achieved with minimum inputs of fossil fuel. The biomass availability and the potential to produce more biomass in those countries which are in the tropics is many times higher than in the major industrialized countries which are exclusively situated in temperate zones. But we have only just begun to recognize the potential of tropical feed resources, let alone devise ways of exploiting them in a way which will be sustainable.

Another factor likely to become increasingly important in the future is the potential for tropical soil-based ecosystems, derived from decaying biomass, to foster atmospheric nitrogen fixation (Patriquin and Moncado, 1992), sequester carbon (Hall *et al.*, 1991) and oxidize methane (Keller *et al.*, 1990; Mosier *et al.*, 1991). Threats to the environment come from:

- atmospheric contamination (global warming),
- deforestation,
- accelerated erosion,
- soil and water pollution,
- loss of biodiversity, and
- excessive human aspirations and lack of awareness of the finite nature of renewable resources.

### **Global warming**

Livestock production is intimately linked with build-up of atmospheric carbon dioxide and methane since: (i) emissions of carbon dioxide are caused mostly by burning fossil fuel and tropical deforestation; (ii) some 20% of methane emissions arise from digestive fermentation in the gut of herbivores, the methane itself contributing to some 15% of total greenhouse gases.

Forests and high biomass producing crops are important sinks for carbon dioxide (one hectare of sugar cane is a permanent sink on average for some 80 tonnes of this greenhouse gas). Decaying biomass in contact with soil appears to be an important ecosystem where anaerobic micro-organisms oxidize methane (Keller *et al.*, 1990; Mosier *et al.*, 1991). Use of animal traction reduces the burning of fossil fuel; and permanent (as opposed to slash and burn practices, which provide for natural regeneration of the forest) tropical deforestation is mostly caused by activities leading to establishment of pastures for extensive ruminant livestock production.

Alternative methods of livestock production using high biomass-producing crops, fed mainly to monogastric animals and small herbivores, in partial or total confinement, will lead to increases in the size and number of sinks for both carbon dioxide and methane.

### **Deforestation**

Extensive cattle grazing is the principal production system employed by the colonizers of rain forests and has been, and still is, encouraged by most state agencies for rural development and agrarian reform, even though scientific research has demonstrated clearly the failure of this system in most tropical ecosystems (IGAG, 1988). Livestock production parameters in extensive grazing systems in tropical developing countries are notoriously poor. The average fertility rate rarely exceeds 50% and is often less; average stocking rates are less than one mature cattle unit per hectare; slaughter age for 450 kg live weight steers is more than 40 months; mortality rates frequently reach high figures in many regions due to contrasting food supply situations caused by long droughts and dry periods (Salazar and Torres, 1981).

The recent evaluation of a dairying project in Costa Rica provides further confirmation of the unsustainability of tropical pasture-based livestock systems (Holman *et al.*, 1992). Rain forest (4,000 mm rainfall annually) was cut down and burned in 1979-84 to establish *Brachiaria* pastures for family farm resettlement. In 1992, it was revealed that incomes had deteriorated (to less than the minimum wage), soil fertility had decreased, weeds had taken over from the *Brachiaria* and concentrate usage had increased. The authors concluded that tropical pasture milk production was not sustainable and that research was

needed to facilitate transition to other systems of land use.

When cattle grazing systems are the main activity of poor farmers, with insufficient capital and minimal access to credit, returns are usually inadequate to support the basic needs of the family. The consequence is that the land is sold usually to the rich landholders who, through economies of scale, can continue with the extensive grazing systems; the poor farmer turns once again to the forest, and so the destructive process continues. This cycle has been repeated through successive generations during the present century, the situation becoming increasingly severe since the areas cleared of vegetation are highly prone to erosive tendencies, especially the soils in the Andean and Amazonian regions (Murgueitio, 1990).

The peasant farmer sector in Colombia (1-15 ha per farm) accounts for 70% of the rural population, supplies half the national food budget, yet occupies only 15% of the national territory (Minhacienda, 1984). In contrast, extensive grazing systems occupy more than half of the agricultural area of Colombia, are owned by less than 5% of the rural population and still produce very little (annual consumption of cattle meat *per capita* in Colombia is only 20kg; CIAT, 1978).

The contrast with Asian livestock production systems is interesting. In Vietnam, for example, erosion is not a serious problem and even the areas desiccated by defoliants during the war are regenerating vegetative cover. The reason for the environmentally-friendly role of livestock in Vietnam is that there is no recognized pasture-based beef industry. The role of cattle and of buffaloes is to supply the power needed by agriculture. They are therefore kept in the cropping areas and are fed almost exclusively on fibrous crop residues and by grazing on fallow and common lands (Preston, T.R., unpublished observations).

### **Erosion**

Africa's grazing systems are characterized by agro-pastoralism and transhumance. Such systems were apparently sustainable in times of low population density, with little pressure on the natural resource base and with opportunities to move from degraded lands to new territories or to adapt the pastoralist practice (e.g., to herd camels and goats instead of cattle); but they have been destabilized by "development" practices, which have removed former "density-dependent" constraints (e.g.,



through veterinary care, reduction in tribal raiding), or added new constraints (e.g., reduction of range land area due to encroachment of crops and settlement of pastoralists; and increasing herd sizes) (see Ellis and Swift, 1988).

The impact of this destabilization was clearly seen in the Dodoma region of Tanzania (Christiansson *et al.*, 1987). Explosive growth of the population resulted in increasing areas of rangeland being diverted to cropping. At the same time, the livestock herds of the pastoralists were also increasing. The outcome was uncontrolled over-grazing of the non-cultivable areas, leading to severe land degradation, threatening total ecological collapse of the region. The seriousness of the situation resulted in the initiation of a far reaching and, in some respects, unique programme - The HADO Project (Hifadhi Ardhi Dodoma - Dodoma Region Soil Conservation Project).

The HADO project was started in 1973 and was initially concerned with arresting the accelerating land degradation occurring in parts of Dodoma Region through physical soil conservation measures. However, it quickly became apparent that the terraces, bunds, cut-off drains, etc. that had been constructed were not having the desired effect due to their destruction by grazing animals, and also due to uncontrolled water run-off from higher slopes denuded by over-grazing. As a result, a decision was taken in 1979 to close the most severely affected area of over 1,200 km<sup>2</sup> - the so called Kondoa Eroded Area - to all livestock, which involved the eviction of over 85,000 cattle, goats, sheep and donkeys.

A review of the Kondoa area, 10 years after the decision to de-stock (Preston, T.R., 1989, unpublished data), showed that the regeneration of the vegetation, and the arrest of ecological degradation generally in these areas had been dramatic. Honouring the promise to the farmers that some form of livestock keeping would be allowed when the land had recovered, in 1990, the government, with help from SAREC and SIDA, introduced a zero grazing scheme for milk production with improved crossbred and local cattle. Results have surpassed expectations (Ogle *et al.*, 1993), with milk yields of up to 10 litres daily being achieved on locally available feed resources, and with major participation of women in the feeding and management of the cows and the use and sale of the milk.

### **Soil and water pollution**

The problem of soil and water pollution has arisen due to excessive use of chemical fertilizers and insecticides in "green revolution" agriculture. Loss of soil organic matter, which increases the need for fertilizer inputs, through monoculture of exploitive crops such as cotton and cassava has been a contributory factor.

A related issue is the effect that excessive chemical fertilizer application and burning of crop residues has had on natural ecosystems. There is increasing evidence that high levels of nitrogen fertilization decreases fixation of atmospheric nitrogen in the rhizosphere of, for example, sugar cane (Patriquin, 1982); and that it increases emissions of nitrous oxides and decreases oxidation of methane (Mosier *et al.*, 1991). By contrast, leaving post-harvest cane trash on the soil as a mulch, instead of burning it, increases sugar cane yields (Mendoza, 1988; Phan Gia Tan, 1994) and soil fertility (Phan Gia Tan, 1994).

The integration of livestock with crops provides both nutrients for the plants and organic matter as an energy source for soil micro-organisms to aid soil fertility. On a specialized crop farm there may be little incentive for planting break crops of legume forages. But if livestock are present then such forages can be turned into income by feeding them to animals. Planting of multi-purpose nitrogen-fixing trees in association with cash crops, as in "alley farming" systems, is also more attractive to the farmer if some of the foliage can be used to give added value to livestock (Attah Krah, 1991).

### **Loss of biodiversity**

Genetic selection for livestock of ever-increasing productive potential has inevitably lead to decreased biodiversity at the animal level. Intensive feeding systems for monogastric animals, almost exclusively tied to use of cereal grains and soya bean meal, have encouraged replacement of indigenous ecosystems and local strains of cereals with 'more productive' hybrids. Emphasis on specialized grazing systems in the tropical savannahs has created vast expanses of pasture monocultures of *Brachiaria* spp. In both cases plant biodiversity has been reduced.

The positive side of increasing affluence is the opportunity to choose more on quality and less on price. In Colombia, eggs from scavenging 'local' poultry were preferred and brought higher prices than those from

'battery' birds (Solarte *et al.*, 1994a). Meat from an indigenous pig breed had a better taste than that from imported 'improved' breeds and was preferred by local inhabitants in Guadeloupe (Depres *et al.*, 1994). The meat from non-ruminant herbivores living in natural ecosystems is considered to be a delicacy (and therefore worthy of a higher price) in many tropical countries.

The search for alternatives to cereal grains and protein-rich oilseed and animal by-product meals (Sansoucy, 1994) is already leading to the identification and promotion of a wide range of indigenous (to the tropics) crop and water plants, trees and shrubs. Biodiversity will be enhanced by these practices which should be encouraged (e.g., by more research).

### Human aspirations and the resource base

**Figure 1.1. The demand for energy (mostly as fossil fuel) will increase most rapidly in the least-developed countries as they aspire to the living 'standards' of the industrial countries (Source: The Economist, June 18 1994).**

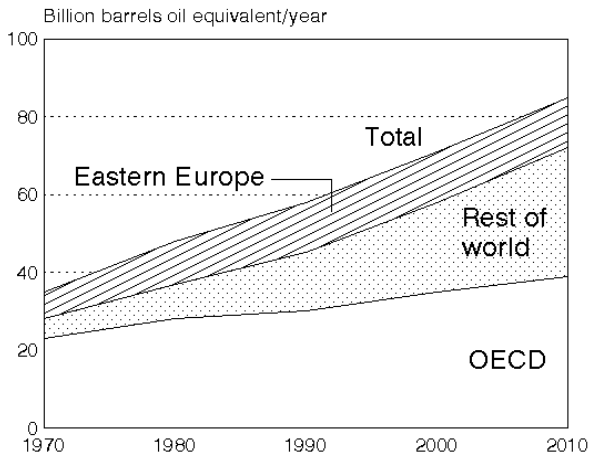

The economic strength and the standard of living of the industrial countries is directly linked with their consumption of fossil fuel (Figure 1.1). The aspiration of the less-developed countries is to follow a similar

route. But reserves of fossil fuel are finite and have a lifetime measured in decades, not centuries. Hydro and nuclear power pose serious threats to biodiversity and to contamination with hazardous wastes, with fewer opportunities for employment.

The only sustainable solution is to promote life styles, and goods (of which energy is a priority), which are derived from activities associated with the development and management of natural biologically-based resources. For the researcher in a tropical country, responding to this challenge should be a privilege and source of satisfaction, long since absent from the agenda of their colleagues in industrialized countries for whom agriculture is of declining importance.

### **RENEWABLE AND NON-RENEWABLE (FOSSIL) ENERGY**

The close link between livestock policies and fossil fuel use has been mentioned. Three examples put this in perspective. On the 30,000 ha sugar estate in the Dominican Republic (La Romana), some 18,000 oxen haul the sugar cane from the fields to pickup points on a railway system leading to the sugar mill. This system is highly sustainable since the energy for the oxen is derived from the carbohydrates in the cane tops; nitrogen and minerals in the tops are returned to the soil in their excreta, since the animals eat and rest in the recently harvested areas.

By contrast, in Cuba, some 80% of the sugar cane is harvested mechanically by diesel-driven combines and loaded onto trucks which transport the stalks and attached trash to cleaning centres. Here, electrical power is used to blow off the trash and the stalks are elevated onto rail wagons or trucks for continued transport to the factory. This system is not sustainable. At the time of writing this manual, the problem of de-mechanization of Cuba's agriculture was the subject of keen debate.

The example of Vietnam has already been mentioned, where agricultural power is supplied almost exclusively by buffaloes and oxen, and bicycles are the major means of personal transport. Vietnam's rating in terms of GNP may be one of the lowest in the world but, if it were assessed in terms of sustainable agriculture, it would be among the leaders. By contrast, in most tropical countries in Latin America, oxen have been replaced by tractors and forests are burned to develop pastures for beef cattle. These policies are highly unsustainable.

A specific problem of less-developed countries is the provision of

domestic fuel for the more than 2,000 million families that use firewood from woods and forests for this purpose. In Colombia, it is estimated that 29% (240,000 ha) of the annual rate of deforestation (800,000 ha) is caused by domestic fuel wood consumption, half of which is in rural households, a third in poor urban communities, the remainder divided between charcoal production (9%) and rural handcrafts (11%). The amount consumed varies from region to region, but it is calculated that a rural family of 8 persons uses 18 cubic metres (about 3.6 tonnes) of firewood annually solely for cooking. If this is purchased then it may cost (in Colombia in 1990) up to US\$70.00/tonne. When cut from the forest, it is estimated that 50 work days are expended annually for this purpose, with a value of US\$147.00 (Solarte, L., personal communication). The situation in much of Africa and in parts of Asia is similar.

Several solutions have been proposed which involve livestock. They are complementary and depend on natural and economic resources available and on cultural acceptance of the technology on offer:

- biogas digesters,
- establishing energy plantations, and
- use of crops that fractionate easily into "feed" and "fuel" components.

Biogas technology was first developed in India and China. The mixture of methane and carbon dioxide (biogas), produced by the anaerobic fermentation of livestock and human excreta, has found major uses in cooking. Biodigesters are intimately linked with livestock production, as they depend for substrate on the excreta of animals. Thus, use of this technology strengthens the arguments for partial or full confinement of animals, and thereby forms part of the strategy against uncontrolled grazing. The major constraint to the popularization of biodigesters has been cost and availability of suitable materials for their construction. The recent development of low-cost (less than US\$50/family unit) biodigesters using standard polyethylene tubular film (Preston and Botero, 1988) has had a major impact in Vietnam (Bui Xuan An *et al.*, 1994) and Cambodia (Than Soeur, 1994) where the even lower costs (less than US\$30.00/family unit) put the technology within reach of the majority of families.

Cereal crops are easily separated into grain and straw. The latter is burned for fuel on open fires (with low efficiency) in many developing

countries. But increasingly in industrialized countries, especially those with strong legislation against uncontrolled burning, it is used as fuel in boilers designed for this purpose. In Denmark whole villages are heated in the winter using this technology. In tropical countries, there are even greater opportunities for applying this principle. Production of sugar from sugar cane is one of the few agro-industrial activities which is self-sufficient in energy (and can even be an exporter of energy). In Vietnam, the growing of enough sugarcane to feed four pigs (with the juice) produced fibrous residues (the pressed stalk) sufficient to cover half the fuel needs of a family of six (Nguyen Thi Oanh, 1994). The concept of the multi-purpose biomass refinery, in which the juice is the basis of animal feed or chemicals and the fibre is converted to synthesis gas to power gas turbines for electricity generation (Preston and Echaveria, 1991), promises to be a more viable - economically, sociologically and ecologically - than the single-purpose production of alcohol as in the Brazilian model. Multi-purpose trees can also be fractionated easily into feed (the leaves) and fuel (the branches and trunks) and can thus be part of the same "integrated" model.

Energy plantations are important for the arid and semi-arid regions as they are complementary to pastoral-forestry schemes. Many species that can be used also fix atmospheric nitrogen and produce edible foliage and/or fruits. They include: *Acacia*, *Prosopis*, *Leucaena*, *Gliricidia*, *Guazuma*, *Inga*, *Albizia*, *Cassia*, *Pithecellobium* and *Alnus* spp. They may be sources of food, feed, fuel, timber and protection against erosion and desertification. These systems can also be the basis of biomass refineries as described above.

Thus the promotion of sustainable systems of agricultural production, in which livestock play a fundamental role, can also contribute to the solution of the domestic energy crisis. The use of multipurpose crop plants and trees, and the recycling of livestock excreta, provide not only much needed domestic fuel, but also control erosion, reduce contamination and act as sources of fertilizer.

## **ETHOLOGICAL ISSUES**

Animal behavior studies were originally conceived as a means of exploiting livestock more efficiently through greater understanding of their habits and activities in different environments. The approach today is quite different. Behavior studies are done so as to develop less exploitive methods of animal production. The aim is to reduce stress to the animal and the attendant so that the quality of life of both is improved (Fox, 1988).

By contrast, the deliberate promotion of contentment through natural means can be reflected in higher productivity. The calf, lamb or kid that is suckled by its mother will grow faster, be healthier and have a better feed efficiency than if it receives its milk from a bucket. The dam will also respond to the more natural environment of having her offspring present at milking, and having it suck the residual milk from the udder. Milk yield will be higher and udder diseases less than if calves are weaned permanently soon after birth (Preston, 1983; Preston and Vaccaro, 1989). Calves suckled naturally do not have the urge to suck the navels of their neighbours and thus can be managed in groups instead of being confined to individual pens. Sows fed fibrous feeds during gestation are less prone to develop anti-social behavior (e.g., biting of tails and ears) than when high nutrient density feeds are given. They can then be managed in (more social) groups rather than in separate individual stalls.

Stressful systems of livestock management, such as raising animals in cages and stalls, are already being legislated against in many countries in Europe. Practices such as debeaking of birds housed in cages, amputation of the tails of pigs and castration, reduce productivity and invite cannibalism.

Embryo transplants have been heralded as a means of increasing beef cow profitability by inducing multiple births and thus raising prolificacy (King, 1989). However, this technology can result in a high degree of stress in both the cow and her attendant. The long term effects are likely to be reduced lifetime fertility. Stimulation of cow milk yield by injecting recombinant growth hormone appears to reduce longevity and to increase stress (Kneen, B., 1994; personal communication) through accelerated

partitioning of nutrients from body tissues into milk. The welfare of these cows is certainly decreased and cannot be considered to be sustainable.

The direct economic cost of stressful systems of management will ultimately be reflected in the market place with premiums for products from contented and well cared-for animals and penalties for products of animals that are ill-treated.

The transformation of both extensive cattle ranching and the highly intensive methods practiced in monogastric animal production, into more integrated systems in which the livestock play a catalytic and complementary role rather than being the primary goal, will bring with it related advantages in terms of animal welfare.

### **WHOLESOME (NATURAL) FOODS**

In an increasing number of supermarkets and stores in the industrialized countries, premiums are paid for food produced in "environmentally-friendly" farming systems. Crops that are grown according to "organic" farming principles are in this category; as are animal products (e.g., meat and milk) derived from such cropping systems.

The ban on imports to EU countries of beef from cattle treated with synthetic hormones shows how this concern for more natural food translates into economic criteria.

### **INAPPROPRIATE MODELS DERIVED FROM INDUSTRIALIZED COUNTRIES**

The issue here is that, in contrast to crop production, livestock systems in tropical developing countries have been highly influenced by practices developed in the industrialized countries, most of which are in temperate climatic zones. For example, most "modern" methods of pig, poultry and dairy production in tropical countries are almost exact copies of those practiced in industrialized countries, using the same germ plasm and feed resources. The term 'assembled' is often used to describe the products derived from such systems to emphasize their dependency on imported inputs.

Such practices have been justified by the need to respond to the aspirations inherent in a 'better standard of living' through increased



consumption of food of animal origin. In fact, they exacerbate the basic problems since they result in:

- Minimum employment opportunities.
- An increase in the foreign exchange deficit, due to high imports (some countries import 100% of their feeds for industrial-scale pig and poultry production).
- More pollution, as usually the animal population in such units is high and there are no associated crops for recycling the excreta.
- Impoverishment of the small scale farm family, which cannot compete in the purchase of the required inputs and may not have the skills for the more sophisticated management that is required.

Countries such as Nigeria and Venezuela, which built up sophisticated intensive animal industries in times of high oil revenues, found that these were not sustainable when oil prices fell and agricultural subsidies had to be reduced.

### **INDICATORS OF SUSTAINABILITY**

Indicators of sustainability are derived from measurements which describe the effect of the system on the sustainability of the resource. While this topic is presently the subject of much discussion, the following parameters are proposed as criteria on which the sustainability of resource utilization can be measured. The items (not in order of priority) include:

- Total biomass yield.
- Soil organic matter content.
- Soil pH.
- Soil content of P, N, K, and Ca.
- Degree of diversity of animal genetic resources and their use at the level of small scale users.
- Water quality.
- Production and use of renewable energy.
- Use of fossil energy.

- Energy balances.
- Diversity in fauna and flora at plant and soil level.
- Greenhouse gas emissions and sinks (carbon and methane).
- Employment generation.
- Involvement of women and children.
- Food security.
- Maintenance of lifestyle of households in rural areas.
- The catalytic role of livestock in the integration of crops, livestock and forestry.
- Protection against erosion and desertification.

Using the above criteria it has been the experience in several tropical countries that the production and use of feed resources derived from sugar cane (small scale - not industrial), African oil palm, sugar palm, forage trees and shrubs, and most water plants, can be sustained. The use of cereal crop residues (but not always the production) is also a sustainable feeding system as the primary product will always be produced for human consumption. By contrast, cultivation of cassava, cotton and "introduced" tropical pasture species is unsustainable due to negative effects on soil fertility and, in the case of tropical pastures, due to negative effects on socio-economic indicators (e.g., employment, and persistence of households in rural area).

## **CONCLUSIONS**

The issues discussed in this chapter provide a conceptual basis for the sustainable use of renewable natural resources in livestock-based farming systems for the tropics. The interpretation of this strategy in the form of practical farming systems has profound implications both for the type of feed resources that will be on offer, the species of livestock most suitable for their utilization, the most appropriate way to evaluate them and the manner in which such feeds should be incorporated into the diet of the animal.

Chapter 2

## **Identifying priority areas for research on tropical feed resources**

*This chapter provides general guidance on where to look for information and advice on tropical feed resources. It lists some of the promising new areas for research that are emerging as emphasis is directed towards the sustainable use of renewable natural resources.*

It has been intimated in Chapter 1 that future livestock production systems will be predicated not on maximizing the productive rate of a given animal species but in helping to meet the demands of society for the basic necessities of energy, food and shelter. These needs will have to be met with feed resources which will be the by-products and residues of cropping systems designed to optimize production of biomass with minimal external inputs, to maintain biodiversity and to protect the environment.

In such a scenario, livestock must not be in competition with the human population for resources; rather, they should play a complementary and, where possible, a synergistic role.

### **TRENDS IN THE ORIGIN AND NATURE OF FUTURE FEED RESOURCES**

Available feed resources are determined by the way land is utilized. The choice of agricultural systems will reflect the demands of the human population and the nature of the ecosystems which in turn will be determined by available moisture, the nature of the terrain, the fertility of the soil and the pattern of rainfall (FAO, 1993).

**The demands of society**

Human society requires energy (for cooking, light, crop cultivation and transport), food, a source of chemicals, shelter, and employment. There is good reason to believe that human food production can be sustained even with an increasing population. There are local food shortages but world supplies are more than adequate as evidenced by the fact that the major part of the world's cereal grain production is fed to livestock. By contrast, the present global level of energy use is not sustainable, as it depends on finite supplies of fossil fuel. Thus while, in the past, production of food for human consumption has been the priority activity, in the future, provision of energy will begin to take precedence.

Present feed resources for livestock result mainly from activities directed towards human food production. In the future, they will increasingly be derived from the residues and by-products of energy production.

**Natural ecosystems**

Fertile river deltas and valley floors will continue to be priority areas for rice production. However, pressures to increase yields and to reduce agro-chemical inputs will favour the introduction of rotations and associations with high biomass yielding crops that raise soil fertility while still contributing food and fibre. Sugar cane, with its unrivalled capacity for raising soil organic matter, the African oil palm and other multi-purpose trees are likely to become increasingly important components of these ecosystems as the search for renewable sources of energy increases in intensity.

Continuous rice culture as presently practised (with high-yielding varieties and agrochemical inputs) is not sustainable. This is confirmed by the results of a recent study from the International Rice Research Institute (Cassman, 1993) which shows that rice yield response to increasing fertilizer application is falling. Increasing the sustainability of rice production is most likely to be achieved by diversification (e.g., introduction into the rotation of "fertility-raising" crops, and closer integration with livestock). The traditional rice-duck-fish system has already proved to be an excellent biological control mechanism. Livestock manure was, and still is in many areas, the only fertilizer

required if it is supported by diversified restorative cropping. But, as long as fossil fuel is cheap, animal traction (one of the main sources of the manure) will continue to be threatened by mechanization, creating an incentive for increasing use of ago-chemicals. So begins the process of disintegration of the system, and dependence on outside inputs.

The Chinese deep pond and dyke system, sustained for thousands of years in the high water table region along the Pearl river, although demanding of capital (or labour) for its establishment is probably the most productive and highly sustainable way of farming these otherwise difficult (but only in the conventional sense) "water-logged" areas (Chan, 1993). Unfortunately, these systems which have sustained thousands of farmers over generations are also being threatened by the ago-chemical inputs of "modern" technology and the demands of an increasingly "consumer- oriented" society (Chan, 1993).

On hillsides and sloping land at elevations below 2,000 m, sustainable land use requires the cultivation of perennial crops as the basic activity. Systems of agroforestry are the only sustainable alternatives. They offer many options, including associations with short-cycle food crops and with grazing of livestock. But trees, in some form or other, must dominate such landscapes in the future.

Finally, there are the arid and semi-arid regions (less than 400 mm annual rainfall) where the only sustainable option is the cultivation of drought-resistant trees and shrubs, among which the *Prosopis* spp. have already shown their potential (Habit and Saavedra, 1988).

### **FEED RESOURCES FOR TROPICAL LIVESTOCK PRODUCTION**

Four main categories of feeds will be dominant in tropical regions as pressure to carry out sustainable agricultural practices increases. These will be:

- The fibrous residues from crops grown for human food production. Pre-eminent here will be the straws and stovers from cereal grains, mainly from rice but also from sorghum, millet and maize.
- New feed resources derived from crops grown primarily as sources of renewable energy, or as contributors to soil fertility. In this category will be the range of products and by-products derived from

sugar cane, African oil palm, the sugar palm tree, other multi-purpose trees (especially leguminous ones) and aquatic plants. These are rich in readily available energy (the juice from sugar cane and sugar palm, the oil and fruit from the African oil palm) or in protein (the leaves from multipurpose trees and aquatic plants).

- Other by-products and residues.
- Natural pastures, although their role is decreasing, will provide, for some time, the bulk of ruminant feed. However, there is a wealth of data on grasses and conventional forage crops. There will be little to be gained by doing more research with these feed resources.

A wide range of by-products and residues results from other food crops and cropping systems. In general, information exists on the nutritive value of by-products of oilseed and cereal milling. It is more important to know where the existing information can be found, which is the next point to be discussed.

## **SOURCES OF INFORMATION ON TROPICAL FEED RESOURCES**

### **The electronic highway**

It is a logical corollary to the discussions in Chapter 1 and above that little of the information required in order to promote sustainable livestock-based rural development will be found in the classical text books and journals, and even less so in the standard texts on "how to feed livestock" (e.g., the bulletins of NRC, ARC, INRA, Australian Feeds and similar sources). These sources relate neither to the tropics nor to sustainable development.

Information both on tropical feed resources *per se*, and the interpretation of this information in the light of developing sustainable solutions, is in a rapid and dynamic state of flux. One example will suffice to demonstrate this. The first literature citation indicating the enormous potential of the fruit of the African oil palm, as opposed to the by-products of oil extraction, as the basis of an intensive system of pig production has only just appeared (Ocampo, 1994b, published in the computerized journal *Livestock Research for Rural Development*, Volume 6, Number 1). If it had been submitted to a traditional scientific

journal, it would be "in preparation" (and therefore largely inaccessible) for a minimum of 12 months and perhaps even longer.

The first step in the search for information is for researchers to join an electronic mail network and contact the person or institution working in their areas of interest. Through this same network, the researcher will be able to access relevant scientific articles, abstracts, notes and observations from practising farmers, relating to what is happening "now", not what was researched 2-3 years ago - before sustainability became an issue.

Guidance on how to join one or more of the appropriate electronic mail networks serving developing countries is given in Chapter 13.

### **Tropical feeds**

The most useful information on tropical feed resources is found in the computerized database "Tropical Feeds 1994", available from the Feed Resources Group at FAO HQ in Rome. The most recent version of this program contains new data on fibrous crop residues and alternative "high biomass" crops such as sugar cane, multi-purpose trees and water plants. The decision to complement the compositional and descriptive information on feeds with a discussion on their use in practical feeding systems is especially commendable. Abstracts - where appropriate - of the original papers have also been included. The programme is now available in the three principal working languages of the UN system: Spanish, French and English (Tropical Feeds, 1994).

### **Computerized international journals dealing with tropical feed resources and sustainable development**

The computerized international journal "Livestock Research for Rural Development" is now in its sixth year. It is available 'on-line' via the APC (Association for Progress in Communication) Networks (GreenNet in the UK; EcoNet in USA). Information on how to obtain the journal by email can be obtained from Andrew Speedy in the UK (speedy@vax.ox.ac.uk), from Gordon King in Canada (gking@aps.uoguelph.ca) and from René Sansoucy in FAO (rene.sansoucy@fao.org).

Three new journals publishing information on tropical feed resources have recently been launched in computerized format. These are:

- "Indice Venezolano de Investigaciones en Producción Animal", produced by the Instituto de Producción Animal, Universidad Central de Venezuela, Maracay;
- "Revista Latinoamericana de Investigación en Pequeños Herbívoros No-rumiantes", published by the Universidad Nacional Experimental Ezequiel Zamora (UNILLEZ), Guanare, Portuguesa, Venezuela.
- "Revista Computadorizada de Producción Porcina", published by the Instituto de Investigaciones Porcinas, Habana, Cuba.

Information on how to obtain these journals can be obtained from Andrew Speedy in the UK ([speedy@vax.ox.ac.uk](mailto:speedy@vax.ox.ac.uk)) and from Rene Sansoucy, FAO, Rome ([rene.sansoucy@fao.org](mailto:rene.sansoucy@fao.org)).

## **PRIORITY AREAS FOR RESEARCH IN TROPICAL FEED RESOURCES**

### **Feed resources and sustainable development**

Cereal grains are the staple food of the bulk of the world's population. The areas devoted to their cultivation, and the yields obtained, have steadily increased, mainly through the use of inputs derived from fossil fuel. Cultivation of cereals at these extremes of the yield response curve is not sustainable viewed in the context of the long term. However, cereal crops can be part of a sustainable cropping system, in which other crops are grown to restore the fertility exploited by the cereals. Ley (rotational) farming was introduced into Europe in the 18th century for this very purpose. The livestock farming network based around the rice crop, coordinated by IRRI (Carangal, 1993) is an example of this approach. Similar initiatives are needed in the other tropical continents.

In temperate regions of the world, cereal production exceeds what is needed for human consumption. The surpluses are fed to livestock and considerable amounts are exported. In contrast, most tropical countries (Thailand and Vietnam are the exceptions) import part of their needs of cereal grains for human consumption and many of them also import grain for feeding to livestock. In tropical countries, promoting the use of alternative feed resources, derived from crops which are more "environmentally friendly", will lead to more sustainable development and will increase self-reliance (Sansoucy, 1995). The major objective of



this manual is to encourage the use of these alternative feeds and, through research, to improve the efficiency of their utilization at the level of small-scale farmers.

It should also be stressed that for many new "alternative" feed resources, learning how to grow them will have a higher priority initially than characterizing their nutritive value; which is a way of emphasizing that researchers concerned with developing sustainable livestock-based production systems in the tropics must be prepared to approach the problem in a multi-disciplinary fashion. For agronomic knowledge will often be an essential prelude to being able to use a particular plant as a livestock feed.

### **Cereal grain substitutes for monogastric animals**

Considerable advances have been made in the development of feeding systems using the products and by-products of sugar cane and the African oil palm (Figuerola and Ly, 1990; Sarria *et al.*, 1990; Perez, 1994; Ocampo *et al.*, 1990a,b; Ocampo, 1992; Ocampo, 1994a,b,c), crops that with appropriate management have proved to be sustainable, as judged by the indicators set out in Chapter 1. The principal nutritional elements in these feed resources are sugar and oil respectively. There is insufficient knowledge about both these nutritional fuels, how best to complement them with protein and other support nutrients, and what their effect is on the composition and nutritional quality of the products when they are the basis of the diet. Much work has been done with the cassava plant, designed to promote its use in livestock feeds (Buitrago, 1990). However, the major emphasis has been on producing a dry meal from the roots that could be used in conventional mixed feeds. This suited the interests of exporters (e.g., Thailand and Brazil) and feed millers and compounders in the developed countries, but the added processing costs usually put the dry product outwith the financial means of small-scale farmers, who were usually the original growers of the crop. Future research with cassava and other root and tuber crops should be directed to simple ways of on-farm processing and conservation, so that the growers can also be the major beneficiaries.

A relatively new feed resource, especially appropriate for the dry and semi-arid ecosystems, is the fruit from trees such as *Prosopis* spp.

Many of these tree fruits are rich in soluble sugars and gums. There is little documented information on their nutritive value or on ways in which they are being used or how they could be used better if managed in the most appropriate way.

In general there is an urgent need to promote feeds and feeding systems that are farm-based, rather than relying on purchases of a "balanced" and "expensive" feed from a factory.

## **ALTERNATIVE SOURCES OF PROTEIN FOR MONOGASTRIC AND RUMINANT ANIMALS**

### **Oilseeds and pulses**

The traditional sources of protein in the diets of monogastric animals are the by-products from oilseed milling and the processing of livestock, including fish. Although village-based processing is still the norm in some countries, the process of "development" has led to intensification and scaling-up of poultry and pig production in vertically integrated enterprises encompassing all aspects of the production cycle. This has made it difficult and costly for independent small-scale producers to acquire these feed resources.

There is an urgent necessity to develop protein sources that can be produced and processed on the farm. There is scope for the cultivation of traditional protein crops such as soya bean, groundnut, sunflower, as components of integrated and associated cropping systems. Unconventional legumes such as *Canavalia ensiformis* and *Canavalia gladiata* have received attention from researchers in Africa (Udebibie, 1991), and especially in Latin America (Anon, 1993) but, as yet, there is little impact at the level of the commercial farmer.

### **Multipurpose trees**

Multi-purpose trees are essential features of sustainable development in all less-developed countries, but especially those in the tropics. Thanks to the enormous biological diversity within tropical trees and the accumulated experience of indigenous communities it is possible to advance rapidly in the identification, nutritional characterization (including the presence of secondary plant compounds), cultural needs and growth patterns in associations with other species. There are

hundreds of species in more than 40 botanical families and, within species, a wide range of provenances, many of which are already proving their "sustainability" (Molina, C. and Molina, E., personal communication, 1994). To be able to take advantage of these "indigenous" riches is a stimulating challenge for researchers in the less-developed countries.

Research efforts should be concentrated on: (i) identification of the secondary plant compounds in the leaves and how these are affected by soil, climatic and cultural practices; (ii) developing ways of neutralizing those compounds that have anti-nutritional effects (e.g., by simple ensiling and other fermentation methods); (iii) increasing the availability to digestive enzymes of the amino acids in plant material consumed by monogastric species; and (iv) finding combinations of leaves which maximize "by-pass" characteristics of the protein for ruminants.

### **Water plants**

Where rainfall and/or irrigation are adequate, water plants are highly productive sources of protein-rich biomass and are ideal complements for fibre-free basal diets such as molasses, sugar cane juice and palm oil in pig and poultry feeding systems. As with the trees there are many species to choose from, each of which has its special characteristics which makes it more or less suitable for a given ecosystem. They satisfy the sustainability indicators (Chapter 1) and fulfill a particular niche because of their capacity to decontaminate water excessively charged with organic matter and plant nutrients.

The leaves of most water plants are more digestible than the leaves from trees and, generally, they appear to have low concentrations of anti-nutritional factors. The problem in practice has proved to be more in the area of agronomy than in nutrition. It is almost certain, that at the present time, learning how to grow water plants in continuous culture has a higher priority than characterizing their nutritive value.

### **Unicellular protein**

It is time to return to this subject but from the point of view of natural ecosystems rather than the fossil-fuel based schemes which have largely failed because of health-related issues (e.g., yeasts using petroleum derivatives as substrate) or cost (e.g., torula yeast from sugar cane derivatives). *Spirulina* has the potential to reproduce at a high rate on

biodigester effluents (Ho Thi Kim Hoa *et al.*, 1994), and has an amino acid pattern ideally suited to complement low-protein, energy-rich feeds derived from tropical resources such as sugar cane and African oil palm. Recent developments on the growing of *Chlorella* and *Snedecus* algae show promise as the basis for a low-cost method of harnessing solar energy and atmospheric nitrogen fixation to produce high-quality protein; potential rates of productivity of 9,000 kg protein/ha/year were reported by Chowdhury *et al.* (1994).

### **Worms, insects and larvae**

Cultivation of the Californian Red Worm on livestock excreta has proved to be a commercially viable method for producing concentrated organic fertilizer (humus) on farms in Colombia (Rodriguez, L. and Cuellar, P., 1994, personal communication). The worms, which are really a by-product of this process, are a source of high quality animal protein which has potential as a supplement for poultry, especially at family farm level (Arango *et al.*, 1994).

This same medium (livestock excreta) can be used for cultivation of a range of insects and larvae. Peasant farmers on the Pacific coast of Colombia are skilled in disseminating termite mounds in the forest and harvesting the contents as feed for poultry (Solarte *et al.*, 1994a,b).

There is much to be researched in this category of unconventional protein-rich resources.

### **Silage from animal and fish by-products**

In industrial countries there are well developed technologies for recovering by-products of animal and fish processing and converting them into protein-rich meals. However, such facilities are rarely found in tropical less-developed countries, especially at the level of small towns and villages where slaughtering and processing of fish are done in rudimentary conditions and where by-products often become contaminating wastes. In such situations, the ensiling of the by-products, using molasses and crude syrups derived from sugar cane, is a simple and appropriate method of conservation (Perez, R., personal communication). The results of using this method to preserve mixtures of blood and shrimp heads in Vietnam are described by Lien *et al.* (1994).

## UNDER-RESEARCHED LIVESTOCK AND LIVESTOCK SYSTEMS

### Small non-ruminant herbivores

Cardozo (1993) lists the following species as priority candidates for research and development: rabbits (*Oryctolagus cuniculus*), guinea pigs (*Cavia porcellus*), geese (*Anas anser*), iguanas (*Iguana iguana*), picture (*Dascyprocta* spp.), capybara (*Hydrochaeris capybara*) and snails (*Pomacea* spp.).

The advantage of the majority of species in this category is their high reproductive rate and their capacity to select and utilize plants which would not normally be fed to domesticated livestock. Rabbits, snails and guinea pigs, are traditionally managed in confinement. In fact, such a practice is essential in the case of rabbits and snails which rapidly become serious pests of food crops if allowed to proliferate without control. Geese are efficient grazers and their management should probably be based on some form of scavenging system. For the other species, domestication is almost certainly undesirable, and their exploitation in natural habitats is the preferred approach.

### Multi-purpose cattle and buffaloes

The concept of multi-purpose use of large ruminants is gradually gaining acceptance, not least because of the technical and socio-economic failures of most projects that aimed to exploit specialized breeds and management systems. Two main focal points can be identified: the mainly dual-purpose management of crossbred *Bos indicus* x *Bos taurus* breeds for milk and beef production and the triple-purpose management of buffaloes and mainly *Bos indicus* breeds for work, milk and beef. Much more research needs to be done with these breeds and production systems. From the animal nutrition standpoint, interesting areas of work relate to selection, offer level and quality of the predominantly fibrous feeds, the efficient use of which is the prerogative of these breeds and systems. The comparative advantage of the buffalo (mainly the "swamp" variety) is still not well understood and even less well documented. Equally the advantages of restricted suckling of the calves, although highly appreciated and well understood by tropical farmers, poses questions to researchers concerning interactions between animal behaviour (or greater animal contentment), productivity and feed utilization efficiency, as this affects both dam and offspring.

The effect of work on productive traits of cows is highly correlated with nutrition (Zerbini and Gameda, 1994). However, much of the research in this area has been done with the aim of characterizing nutrient requirements rather than understanding how best to manipulate the system in order to optimize use of local feed resources and 'catalytic' supplements. This is a fertile area for study.

### **WHERE TO DO THE RESEARCH: ON-FARM OR ON-STATION?**

In part, it is a question of choosing horses for courses. Most animal feeding research in the tropics, aimed at providing solutions to the complex problems detailed earlier in this manual, is probably done more effectively and more economically on commercial farms than at the experiment station. It is rare to find an experimental station that manages well either crops or livestock. The results then become site-specific (good or bad according to the management) and replication within the station may be of limited value. If management is a component of the hypothesis being posed, then validation should be done on a range of commercial farms.

The screening of potential feed resources should also begin on-farm or in-village. For, in many communities in the tropics, livestock farmers often have no land of their own. It is these latter farmers, usually women, who have developed particular skills in identifying trees, shrubs and plants that have specific nutritional properties (Rangnekar, 1994). In a recent encounter with such resource people on the Pacific coast of Colombia, more than 20 plants were identified by the farmers as sources of feed for their livestock (Solarte *et al.*, 1994ab).

On-station research is indicated when a problem, identified in on-farm activities, requires a form of analysis (usually chemical or biological) which calls for a laboratory or other facilities for which an experiment station is equipped.

On-farm research methodology is different from that applied on-station. It will rarely be possible, or even desirable, to have replications of a treatment on the same farm. Rather the farm itself will be a replicate, for the objective frequently will be to measure the range of variation encountered among farms in which similar interventions are

made. The data in Figure 2.1 demonstrate such a response to introduction of sugar cane juice feeding of pigs in villages in Vietnam.

**Figure 2.1: Growth rates of pigs fed sugar cane juice diets on family farms in villages in Tuyen Quang Province in Vietnam (Source: Preston, T.R., 1993, Unpublished data).**

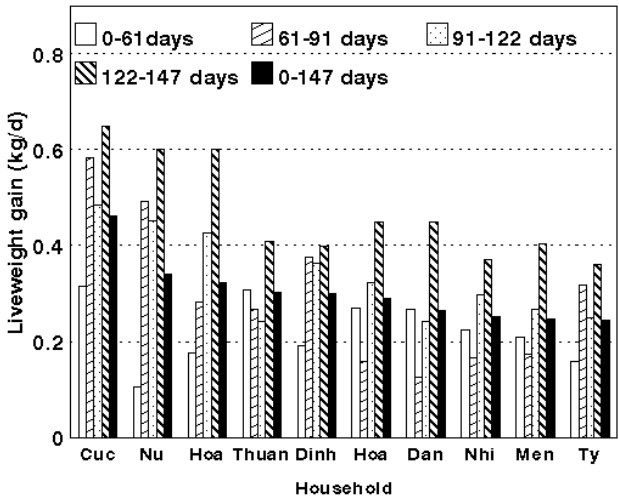

The question that such a response raises is: what is the cause of the variation? A detailed analysis of the activities on each farm, especially those at the extremes of performance levels, will often yield valuable insights into the strengths and weaknesses of a given technology, which would not have come to light under the more controlled conditions of the research station.

## Chapter 3

## Nutrition of non-ruminants

*One of the major challenges to researchers in the tropics is to provide alternatives to the feeding and management systems for monogastric livestock, especially pigs, poultry and rabbits, introduced from temperate industrial countries. These introduced systems are not sustainable as they depend to a high degree on imported inputs. Typically they are large-scale, peri-urban, and vertically integrated with processing and marketing, promoting competition with, rather than participation of, the small-scale rural farmer. In many cases there are minimal provisions for waste treatment in these large-scale units and pollution of watercourses becomes a serious problem.*

*The development of alternative production systems, using locally available feed resources, must start with knowledge on the impact on nutritional requirements of using new feed resources, which are often rich in sugars, lipids and fibre, in contrast with the starch-rich feeds used in temperate countries. Respecting the innate capacity of animals to select a balanced diet from an array of ingredients, and to process feeds in their natural state, will help to maximize the participation of the farmer in the production process and reduce dependency on feed milling and mixing plants.*

### **IMPLICATIONS OF USING NON-CEREAL FEED RESOURCES**

This is not the place to give an extensive discourse on the nutrition of non-ruminant livestock. Text books and bulletins dealing with the species of animals in this category are available and should be consulted if the need is to understand some specific aspect of their digestive physiology or metabolism. Equally, it is not intended to refer to the series of recommendations on requirements for specific nutrients: amino acids, minerals and vitamins. This information is well documented in the bulletins published by ARC (1988) and NRC (1988).



What will be described are: (i) the nutritional consequences of using some of the non-cereal feed resources, mentioned earlier (Chapter 2) and discussed in detail in Chapter 4, as the basal energy supply of pigs and poultry; and (ii) the measures to be taken to obtain the most economical results when such feeds are used. This information is not available in the standard text books, nor in the bulletins of nutrition requirements where it is invariably assumed that cereal grain will be the principal source of energy.

There is another general point to be taken into account in any discussion about feeding standards and requirements. In almost all cases these have been worked out against a background of state-financed or environment-financed support for agricultural products, either directly in the form of guarantee payments or an export subsidy, or indirectly through externalizing the costs implicit in: (i) the damage to the environment, caused by soil and groundwater pollution from discharge of wastes; and (ii) the use of non-renewable fossil fuel-derived inputs. In almost all cases, the final effect is to encourage the maximization of biological performance. The consequence is that feeding systems tend to be predicated on what is needed to reach these levels of performance, rather than on the optimal use of the available feed resources.

The law of diminishing returns operates strongly at the extreme range of the production response curve thus the final increments in performance require high levels of inputs, especially protein. In contrast, in most tropical countries, livestock production is not subsidized and the point of optimum economic performance is found in the lower part of the response curve. Supplementary nutrients are used more efficiently in this case.

Finally, maximum advantage should be taken of the animal's innate ability to: (i) select what is good for it (or what it likes); and (ii) process (i.e., grind with the teeth or in the gizzard, or extract oil or juice by chewing) natural feeds.

## **NON-CEREAL FEED RESOURCES FOR PIGS**

### **The alternatives**

The most promising alternatives to cereal grains for intensive feeding of pigs in the tropics are: sugar cane juice (Mena, 1983; Sarria *et al.*, 1990;

Speedy *et al.*, 1991), sugar cane molasses (High-test, "A" or "B" molasses) (Figuroa and Ly, 1990), juice from the sugar palm tree (FAO/TCP, 1994a), oil, whole fruit and by-products of the African oil palm (Devendra, 1992; Ocampo *et al.*, 1990a,b,c; Ocampo, 1992, 1994a, b), cassava roots (Buitrago, 1993) and by-products (Espinal, R. and Ospina, L., 1993, unpublished data) and organic waste from urban households, restaurants and canteens (Dominguez, 1990, 1991).

Other products and by-products from tree, root and tuber crops, are included in tropical pig diets but mostly on an *ad hoc* basis, and not as the basis of the feeding system.

### **PROTEIN SUPPLEMENTATION OF TROPICAL ENERGY-RICH FEED RESOURCES**

With the exception of the organic waste of urban origin, all the feed resources mentioned above are characterized by very low levels of protein in the dry matter ranging from 1% in sugar cane juice and molasses to 5% in whole African palm fruit. One consequence of this low level of protein in the basal diet is that almost all the requirements for amino acids have to be supplied in a supplement. While this could be considered to be a disadvantage, in fact the contrary may be the case because:

- It is much easier, and may be cheaper, to find a supplement already balanced with respect to the essential amino acids (lysine, methionine, etc.) than to make a supplement that will compensate for the imbalanced amino acid profile present in cereal grains.
- The total amount of protein to be offered is less because when it is derived almost wholly from supplements, rather than partially from cereal grains, it is better balanced in the essential amino acids.

These possibilities can be visualized more easily in the comparisons presented in Figure 3.1 which show that the essential amino acid requirements of sows can be contained in 30-35% less total protein, than what is recommended by NRC (1988) which is inflated by the presence of excessive amounts of the non-essential amino acids present in cereal grains.

The final point is the relationship between the amount (and therefore cost) of the supplement and the level of animal performance. This is

especially important in most tropical countries where the ratio - price of protein : price of energy - is much wider than is the case in temperate (cereal growing) countries. Thus the point on the response curve (to protein) where profit per fattening pig is optimized will not necessarily coincide with the point where biological performance is maximized.

**Figure 3.1. Protein requirements for pregnant and lactating pigs (Essential Amino acids and total protein) (Source: Speer, 1990).**

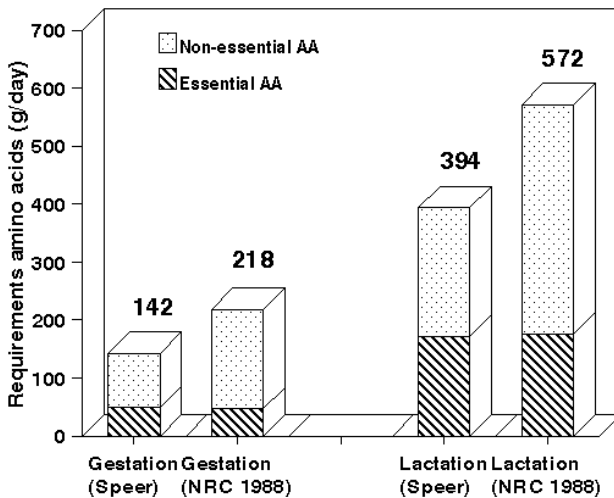

An example taken from Vietnam clearly illustrates this point (Figure 3.2). The regression equations show that for every 100 g/day increase in supply of protein (approximately 200 g/day of soya bean meal), liveweight gain was increased by 55.5 g/day on sugar cane juice and by 48.4 g/day on cassava root meal. Putting the value of liveweight at US\$1.00/kg and the cost of soya bean at US\$400/tonne (the approximate prices in Vietnam in 1993) then a liveweight gain of 55.5 g/day, worth US\$0.055, requires 200 g soya bean meal which costs US\$0.080. Clearly there is no economic advantage in giving more than the minimum amount of soya bean meal (300 g/day = 150 g protein) which will support a liveweight gain of 542 g/day (on cane juice). This is well below the optimum biological response of 684 g/day liveweight gain obtained with 800 g/day of soya bean meal.

**Figure 3.2.** Effect of dietary protein supply on growth rate of pigs fed basal diets of sugar cane juice or cassava root meal (Source: Phuc *et al.*, 1994; Ospina *et al.*, 1994).

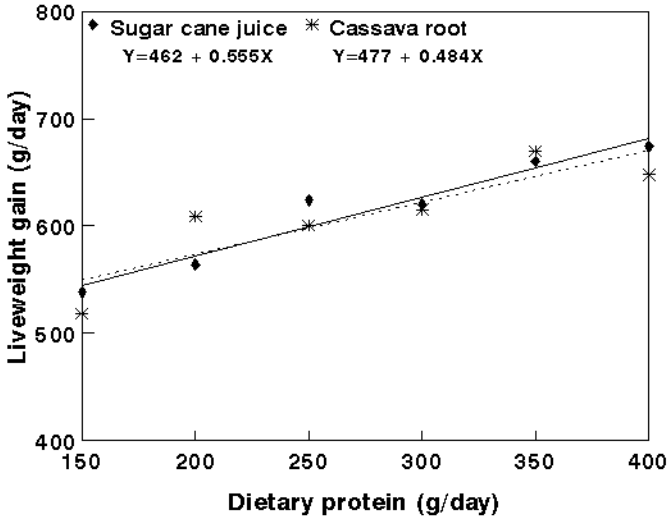

The calculation is a little more complex as faster growth means less time for reaching slaughter weight, and the higher protein level was associated with slightly leaner carcasses, which leads to lower interest and labour costs and increased returns respectively. But even if these factors are taken into account, it will be seen that the fastest growth rate (biologically optimum supply of dietary protein) is not necessarily the most profitable one.

It is almost certainly more important to aim for the biologically optimum ratio of: (i) the essential amino acids relative to one another (eg: as a percentage of the lysine); and (ii) the total essential amino acids relative to the non-essential ones. Wang and Fuller (1989) in an elegant series of experiments using purified diets have provided estimates of both these criteria for growing pigs. In Figure 3.3 the estimated requirements are expressed as a percentage of the lysine. The minimum proportion of essential to non-essential amino acids they estimated to be at least 45:55. Speer (1990) gave estimates of 35:65 and 44:56 for gestating and lactating pigs respectively.

**Figure 3.3: Amino acids in soya bean meal: comparison with the ideal protein (Source: \* Wang and Fuller, 1989; \*\*Tropical Feeds, 1994).**

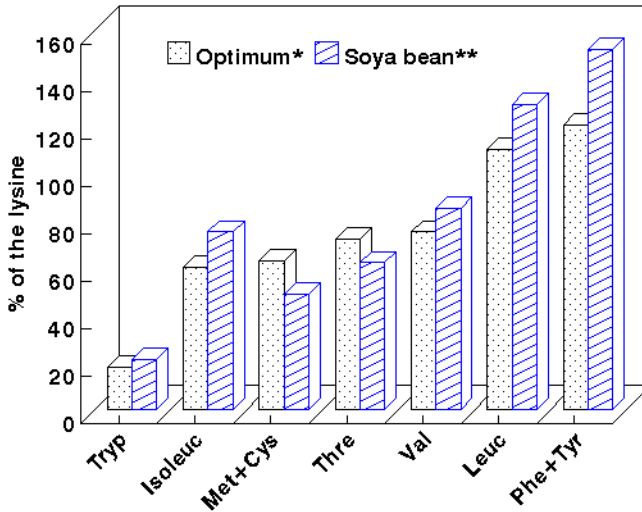

The recommended strategy when balancing tropical energy-rich feeds (such as juice from sugar cane and sugar palm, molasses, cassava root meal, cassava starch processing by-products, palm oil, oil-pressed fibre and oil palm fruit), is to prepare a protein supplement which has a balance of amino acids that resembles as closely as possible that proposed by Wang and Fuller (1989) (Table 3.1). Where a variety of protein sources are on offer, a "least cost" computer program can be used to achieve such a balance. An example of this approach was given by Speedy *et al.* (1991) for preparing a protein supplement to balance sugar cane juice for pig fattening in Swaziland.

For the next step one should ideally be able to refer to regression equations relating productive function to protein (balanced according to Wang and Fuller, 1989) for the particular energy-rich "tropical" feed being used. An example of this approach is given in the work reported by Bui Huy Nhu Phuc *et al.* (1994) and Ospina *et al.* (1994), referred to above (Figure 3.2). Response curves relating growth and carcass traits with supply of a balanced protein (soya bean meal), were determined for basal diets of sugar cane juice and cassava root meal, respectively. From

such data it is possible to calculate the marginal advantage (or disadvantage) of a particular level of protein input in terms of the expected increase in productivity that will result, compared with using a lower level of protein.

**Table 3.1. Balance of essential amino acids in "ideal;" protein and that from soya bean meal (SBM), *Azolla* and *Trichanthera gigantea* (Tg) (Source: Wang and Fuller, 1989; Buckingham, 1978; Rosales, M., Personal communication)**

Amino acid	Proportion in the protein (as % of lysine)			
	"Ideal"	SBM	<i>Azolla</i>	Tg
Tryptophane	18	21	31	NA
Isoleucine	60 75	60	97	
Meth+Cystine	63	49	63	81
Threonine	72	62	72	100
Valine	75	85	103	134
Leucine	110	129	138	172
Phenylalanine +Tyrosine	120	152	149	217

The other point concerns the need or otherwise to increase protein supply with increase in live weight. The experience in Colombia and Vietnam with sugar cane juice, "B" molasses, cassava root by-product and oil palm derivatives, as the basal diet, is that it is simpler for the farmer to give a fixed quantity of protein daily and that there is no economic advantage in having varying levels according to liveweight. The allowances presently used are set out in Table 3.2.

**Table 3.2: Allowances of "ideal" protein for pigs in different phases of the production cycle (Source: Wang and Fuller, 1989)**

Category protein	Liveweight (kg)	"Ideal" allowance (g/day)
Growing-finishing	20-90	200
Gestation	>90	150
Lactation	>90	350

These quantities are based on the assumption that the essential amino

acids will supply at least 45% of the total amino acids and that the essential amino acids will be balanced according to the recommendations of Wang and Fuller (1989) (Table 3.1).

The fact that the regression coefficients linking protein supply with liveweight gain were almost the same for cassava root meal and sugar cane juice (Figure 3.1) indicates that probably other low-protein, low-fibre energy feeds will respond in a similar manner. Support for this hypothesis is found in the results with oil-press fibre (30% oil; zero protein) fed as the basal diet to fattening pigs (Ocampo *et al.*, 1990b). In an experiment with levels of from 500 to 1,000 g/day of a fortified soya bean supplement (soya bean meal with added minerals and vitamins) (200 to 400 g/day protein), there was no biological advantage from giving more than 200 protein g/day throughout the growing-fattening (20-90 kg) period.

It is interesting, in the light of the above recommendations, to refer to an experiment carried out over 30 years ago (1957/58) in Louisiana State University by Thrasher *et al.* (1958). These researchers offered growing- fattening pigs (from 24 to 90 kg) mixed diets with either 0, 20, 30, 40 or 50% raw sugar (replacing maize meal), balanced with soya bean meal, meat meal and alfalfa meal to provide 16 declining to 14% protein; a 6th group of pigs had free access to raw sugar, maize meal and a protein supplement (36% protein from soya bean, meat meal and alfalfa meal). Growth and feed conversion on all treatments were similar (785 to 872 g/day; 3.1 to 3.4 conversion, air dry feed basis) but the pigs on the free choice system only consumed 258 g protein/day, of which 95 g came from the maize and only 163 g from the protein supplement. These same pigs consumed 45% of their diet as sugar. The pigs on the mixed feeds consuming this same level of sugar (average of 4th and 5th groups) consumed 400 g protein daily yet they performed no better than the free choice group which consumed 36% less protein.

It is unlikely that, on all occasions, it will be possible to prepare an "ideal" protein supplement with the perfect complement of amino acids. For all practical purposes, the protein of soya bean is sufficiently close to the ideal protein (see Figure 3.3) as to be the supplement of choice where it is available or can be grown.

In fact, on small farms in remote areas, the availability of protein sources may well be restricted to what can be grown on the farm or at

best complemented with some by-product produced in the nearby village. In these situations it is important to have some idea of the amino acid balance of feeds that can be grown locally. This topic will be discussed more fully in Chapter 4. It is enough at this stage to point to the examples in Figures 3.4 and 3.5 of two foliar sources of protein which can be grown in the tropics: the water fern *Azolla* spp. and the multi-purpose tree *Trichan-thera gigantea*. *Azolla* is readily consumed by pigs, especially during pregnancy. The data in Figure 3.4 indicate that the protein in *Azolla* (about 23% in the dry matter) has an excellent balance of amino acids, better even than soya bean. In this case the limitation to its use will be voluntary intake and the digestibility of the protein.

**Figure 3.4. Amino acids in *Azolla*; comparison with the ideal protein (Source: \* Wang and Fuller, 1989; \*\*Buckingham, 1978).**

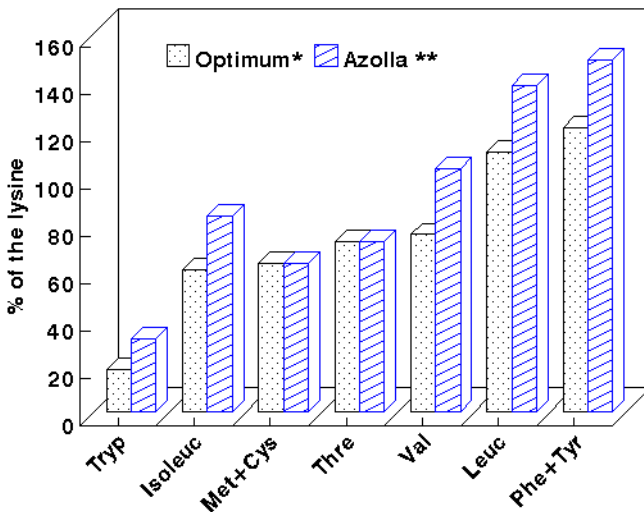

The same is true, although to a lesser extent, with *Trichanthera gigantea*. The protein in the leaves has a good amino acid balance and according to some early work there are few secondary plant compounds (Rosales, M. 1994, unpublished data). Pigs eat it well, especially during



pregnancy. However, even when eaten in amounts that theoretically supply all the protein needs (about 3 kg/day), pregnant pigs rapidly lost body condition when given only *Trichanthera* as a supplement to sugar cane juice (Sarria, P., personal communication). Up to 30% replacement of the soya bean protein by *Trichanthera* appears to be feasible, but either low digestibility or presence of secondary plant compounds appeared to limit its use at higher levels. This aspect will be discussed in Chapters 4 and 8.

**Figure 3.5. The essential amino acids in *Trichanthera gigantea* as percentage of lysine, compared with the ideal protein of Wang and Fuller (1989) (Source: Rosales, M., personal communication).**

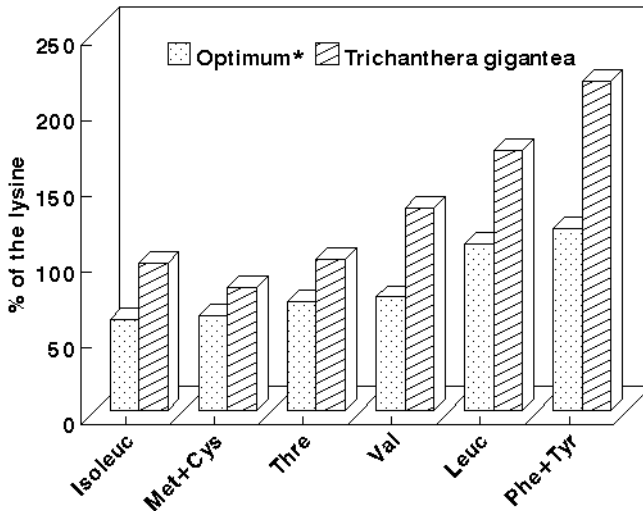

### ENERGY ALLOWANCES

The energy allowances for pigs in the classical tables of feeding standards are expressed in terms of metabolizable energy. At this stage of development of the use of non-cereal tropical feed resources, this is an unnecessary sophistication. The production cycle of the pig can be divided into four stages: gestation, lactation, pre-weaning growth and fattening. It is not very precise to put replacement females in the same

category as fattening, but for all practical purposes the former are not separated until they reach 90 kg. In all categories with the exception of gestation, the general rule will be to feed the basal diet *ad libitum* and to restrict the protein to approximately 65% of the recommendations in NRC (1988). It is emphasized again that the NRC figures for total protein are inflated by the non-essential amino acids present in cereal grain diets on which NRC (and all temperate country) standards are based. When low-protein tropical feed resources are used, the ratio of essential to non-essential amino acids can be set at close to the optimum (45:55) because:

- the total amount of amino acids in the basal diet is low therefore most of the amino acids comes from the protein supplement which is usually well balanced, and
- the protein that is present in tropical energy-rich feeds tends to have a better amino acid balance than the protein in cereal grains.

In gestation the feed allowance will be determined by the energy density of the basal feed. The aim should be to use feeds (or supplements) with low nutritional density so the animal can have free access to at least one component of the diet. In this way, the "hunger syndrome" (abnormal behaviour of sows rationed to small amounts of low volume-high energy density feeds) is avoided. The result is a "contented" sow and the support, rather than the opposition, of animal welfare activists.

## **MINERALS AND VITAMINS**

In this case the indicator of sustainability is "minimum" dependence on outside inputs, especially those sold by feed mills and other intermediaries. Careful selection of the supplement can help to eliminate part of the need for both minerals and vitamins. For example if some palatable and digestible green foliage can be given free choice the pigs will obtain from it most of the vitamins (except for D which is abundantly provided through the medium of sunlight) and trace minerals they need. The major minerals provided by the commonly used protein supplements are shown in Table 3.3. When a mixture of soya bean meal and fish meal (75:25) is used as the protein source it will provide much of the needed calcium, phosphorus and sodium. Sources of calcium (lime) and sodium (salt) are available in most farm households and rural

villages. In some cases the phosphorus can be supplied as phosphate fertilizer. Useful data on vitamin and mineral content of tropical feed resources can be found in Tropical Feeds (1994).

**Table 3.3: Amounts of major minerals supplied by the protein supplement as soya bean meal alone, or in combination with fish meal, *Azolla* or *Trichanthera gigantea*.**

Protein source	DM	P (g/d)	Ca (g/d)	K (g/d)	(g/d)
Soya bean meal		450	1.3	1.3	6.7
50:50 SBM: fish meal		425	7.3	13	5
<i>Azolla:</i>					
30% fattening		200	1.4	3.4	3.6
100% pregnancy		500	3.5	8.5	9.0
<i>Trichanthera gigantea</i>					
30% in pregnancy		200	0.8	4.8	7.6
<b>Requirements (g/d)*</b>					
Fattening		9-12	11-16	2-3	
Pregnancy		11	14	4	

\* From NRC (1988)

## NON-CEREAL GRAIN FEED RESOURCES FOR POULTRY

As with pigs, it must be made clear at the outset, that the purpose of this section is to assist those researchers who believe that poultry and water fowl production should be carried out in a sustainable way respecting the indicators set out in Chapter 1. Feeding systems based on cereal grain will not therefore be discussed. In any event, there is a wealth of information on such systems in the classical text books and bulletins in developed countries.

There appear have been no attempts to re-examine the nutrient needs of poultry in the light of alternative non-cereal grain feeding. One promising development, instigated in the University of New England, Australia (Cumming, R., personal communication), is based on the premise that, given the opportunity to select (in the case of Cumming's

work, between grain and protein supplement), poultry are able to balance their diet according to productive need and environmental stress (high temperature). Cumming and his colleagues have reported economies in feed and no loss of production with this free-choice management system.

The disadvantage of this approach, in the context of tropical feed resources, is that protein-rich feeds in such regions are generally much more expensive than energy-rich feeds. Thus it is almost never profitable to feed protein at a level which will maximize animal performance. For this reason protein almost always will be rationed to secure the most profitable response.

There has so far been no commercial development of poultry feeding systems which use non-cereal tropical feed resources. Work with ducks is the most advanced in this regard (see Chapter 4). But the principles are the same. If tropical feed resources of low protein content are used then the protein supply, balanced according to the "ideal" protein (see above), can probably be reduced to two-thirds of the recommended allowances (NRC, 1988) which, as for pigs, were worked out against the background of cereal grain diets. A factor which may have to be taken into account, especially with ducks, is the need for sulphur-containing amino acids for feather growth. The testing of this hypothesis is recommended as a high priority research area.

The other principles set out for pig feeding on tropical feed resources, with regard to energy, minerals and vitamins, apply equally well to poultry including water fowl.

## **NUTRITION OF NON-RUMINANT HERBIVORES**

The species which are raised commercially in a number of tropical countries are rabbits and guinea pigs. Unfortunately, as in the case of poultry, the intensive "modern" feeding systems are invariably based on conventional, mostly "non-tropical" feed resources and no serious attempt has been made to re-assess their nutritive requirements when alternative "tropical" feeds are used. Advances are now being made in the design of feeding systems for rabbits, using tropical feeds (see Chapter 4), but as yet there are no reports of possible savings in protein requirements, for example that might be achieved by replacing cereal grain with low-protein sugar or oil-rich energy feeds. Theoretically, savings

should be possible as the same arguments concerning digestive processes apply to non-ruminant herbivores as to pigs. There is an urgent need to make such studies in the newly developed feeding systems being used for rabbits, and to begin comparable research with guinea pigs.

The most recent version of the recommendations of the ARC on nutrient requirements of rabbits and guinea pigs was published in 1977 (ARC, 1977). Since this date, much research has been done on the digestive physiology and metabolism in these species, although it has not been interpreted in terms of recommendations on nutrient requirements. It must also be made clear, however, that almost always this research was done using conventional "temperate" feed resources (e.g., maize, soya bean meal and alfalfa), which are neither available nor sustainable in the way they are produced in temperate countries (e.g., dependence on fossil-fuel derived inputs and excessive use of water for irrigation). On such feeding systems the objectives of maximizing biological efficiency led progressively to a reduced capacity to utilize herbaceous plants. Emphasis was put on optimizing availability of glucose and amino acids, which was favoured by the use of diets with high levels of starch (from cereal grains) and preformed protein (from dietary protein). The role of microbial synthesis in the caecum and the utilization of this source of amino acids by coprophagy was largely ignored (Cardozo, A., 1993, personal communication).

For these reasons, researchers in tropical countries are encouraged to take advantage of the opportunities offered in the area of nutrition of "small non-ruminant herbivores" in the tropics, and to participate in the development of feed resources and feeding systems which take account of sustainability criteria. The appearance of a new computerized journal dealing specifically with small non-ruminant herbivores reflects the increasing interest being given to these species (RLPHNR, 1993).

The nutritional requirements of small non-ruminant herbivores are determined by the relative activities of:

- digestion and absorption in the duodenum, and
- digestion by fermentation and absorption in the caecum.
- In the case of the rabbit, the guinea pig and probably the picture (*Dasyprocta* spp.), must be added coprophagy as a physiological recycling mechanism.

The last two processes are ruled out in the case of the snails at least until more is known about the physiology of digestion in these species.

The fact that the small non-ruminant herbivores must satisfy their nutritional requirements by pathways (i) and (ii) has important implications, for example:

- Energy metabolism is based on the utilization of glucose, VFA and lipids.

Therefore, tropical feed resources must be selected according to their capacity to supply: digestible fibre (the source of VFA), sugars and starch (sources of glucose) and pre-formed lipids.

In the tropics, satisfying the energy needs of small non-ruminant herbivores in a sustainable manner probably requires that major emphasis is given to maximizing intake rather than digestibility. The reasons for this are as follows:

- From the physiological standpoint, these animal species have a high capacity to tolerate bulky feeds.
- Optimizing the concentration of fibre in the diet is a way of ensuring that intake is maximized, provided that there is an appropriate balance between the digestible and indigestible fractions. This because these fractions perform separate functions: "fibre" as a source of VFA and "fibre" as a mechanism to stimulate rate of passage. Rate of passage is a fundamental feature of the strategy, because of its close relationship with intake and coprophagy, in the case of the rabbit and guinea pig.
- The role of lipids is important because of the enormous potential in tropical regions of sources of plants that produce these nutrients in the fruit (e.g., the African oil palm). Many trees found in the tropics produce nuts and seeds which are rich in lipids. A tree attracting attention in Venezuela (Cardozo, A., personal communication) produces oil which can be "tapped" from the trunk in a similar way to that used to obtain latex from the rubber tree.

## Chapter 4

## Feed resources for non-ruminants

*There are many feed resources in the tropics that can be used as alternatives to cereal grains for feeding to monogastric animals. Most of these are rich in either carbohydrate (e.g., sugar cane and sugar palm products, fruits, roots and tubers) or oil (e.g., the African oil palm). Almost all are low in protein.*

*The total allowance of protein can be reduced by some 35% (compared with recommended standards for cereal grain diets) when the dietary protein is mainly derived from oilseed meals and animal and fish by-products, since the amino acid profile of these feeds is better balanced than that in cereal grains. There are also opportunities to provide part of the protein from water plants and leaves of trees and crop plants.*

*Research that leads to the identification and appropriate processing of new protein sources from plants with high productive potential will facilitate the adoption of non-cereal grain feeding systems for monogastric animals.*

### **SUSTAINABLE PRODUCTION SYSTEMS**

The first step must be to examine the role of non-ruminant livestock in the overall farming system, so that from the beginning the issues of sustainability in its broadest sense are addressed. The following guidelines are proposed:

- The feed should be grown and processed, the animals raised, and the excreta recycled, on the farm where the enterprise is situated.
- The feed should be derived from a crop that is part of an environmentally sustainable farming system which optimizes biomass productivity per unit of solar energy, minimizes inputs of agro-chemicals, and maintains (preferably enhances) soil fertility and biodiversity.
- The production system should be integrated with other farming

activities so as to optimize (i) use of family labour (especially the women) and; (ii) recycling of excreta as nutrients for ruminants and fish or as substrate for biogas production and as fertilizer for crops raised in both soil and water.

- Maximum advantage should be taken of the animal's innate ability to: (i) select what is good for it (or what it likes); and (ii) process (i.e., grind with the teeth or in the gizzard; or extract oil or juice by chewing) natural feeds.

It is assumed at the outset that future feed resources for monogastric animals in the tropics will not be cereals, but rather locally available feed resources that can be produced on the farm with comparative advantage in sustainable, non-subsidized production systems. This hypothesis gives rise to a series of consequences the outcome of which is that the husbandry of monogastric livestock in the tropics will increasingly differ from that practised in temperate countries.

The available and potentially available non-cereal grain feed resources can be divided into two categories:

- Feeds low in fibre and rich in oil, sugars or starch.
- Feeds rich in protein.

In the category of energy-rich feeds are:

- The products and by-products derived from sugar cane (FAO, 1988).
- The products and by-products derived from the African oil palm.
- Fruits from mainly leguminous trees (e.g., *Prosopis* spp.).
- The by-products from certain food and cash crops (e.g., reject and/or surplus bananas, plantains and sweet potatoes, cassava bran and fines, whey) (FAO, 1992).
- Recycled organic food waste recovered from homes and institutions and from points of storage and sale of agricultural food crops.

Almost without exception all these feed resources are very low in protein (usually less than 5% and closer to 1% for sugar-based feeds). Most (exceptions are sugar cane molasses, the oil-rich pressed fibre from oil palm processing and fruits of *Prosopis* spp.) have a high moisture content at the point of harvest or production. By way of contrast, the



cereal grains used in temperate pig production are relatively high in protein (8-10%) and are harvested with relatively low moisture content.

Since it is expensive in time and energy to dry plant material, feeding systems using tropical resources will increasingly require transport, storage and distribution of the feed in the fresh state (e.g., palm fruits) or as liquids or slurries.

The soluble fractions of sugar cane (juice and molasses), which are rich in sugars, are the feed resources which are steadily having increased impact in pig production in the tropics. However, new possibilities are seen in the African oil palm tree - which combines high productivity, a perennial growth habit and products and by-products of high energy density - and the sugar palm tree. Most of the research with cassava has been directed towards producing a dry meal which could be exported (e.g., from Thailand to the European Union) or incorporated into mixed feeds. Less attention has been given to developing systems for the small-scale farmer.

### **SUGAR CANE FOR PIGS**

The two most important feeds derived from sugar cane are sugar cane juice and molasses. They have special characteristics which must be taken into account when using them as the basis of feeding systems.

- They have a lower energy concentration, compared with cereals, and the main energetic substrate is not starch but a mixture of sucrose, glucose and fructose. Fructose is a poorly studied substrate in pig metabolism.
- They contain no fibre and no lipids, and are practically free of true protein. Additionally they contain variable and imbalanced amounts of minerals and vitamins.
- Molasses has physical properties (e.g., high osmotic pressure, high density, complete solubility) which have consequences from the nutritional and physiological points of view and also in its technological manipulation.

The agro-industrial process of extraction of sucrose (heating, clarification and centrifugation) results in the production of substances

whose chemical composition is not well characterized (for convenience they are described as "non-identified organic matter" (NIAM) and, in the light of practical findings, are not well metabolized by pigs. These substances appear in the sugar cane molasses in proportions which may be as high as 30% in final molasses.

Older pigs (>3 months) are able to extract the juice from chopped sugar cane stems and even from whole stems (Bien-aimé and Denaud, 1989). However, growth rates are only some 60% of what can be achieved when the pigs are fed with juice extracted mechanically (Molina, C., personal communication). There is probably a role for chopped cane stalks for pregnant sows that will benefit from being offered low-energy-density feeds (see Chapter 3). The principle of fractionating sugar cane to secure its most efficient use by livestock and for production of fuel can be applied at a practical level in three ways:

- in the industrial sugar mill (Figure 7.3),
- in a "trapiche" (a crusher with 2, 3 or up to 5 rolls) (artisan system) dedicated to making "gur" or "panela", or
- in a "trapiche" crusher dedicated to livestock (and fuel) production (Figure 7.4).

Pig production systems have been developed for each of the three alternatives described above.

### **High test, "A", "B" and final ("C") molasses**

The grinding of the cane stalk, filtering, clarifying and concentrating the juice and crystallizing the sucrose, are the processes which give rise to molasses (Figure 7.3). There are four types of molasses in the sugar cane industry:

- Concentrated cane syrup (high-test molasses) which has been partially inverted to avoid crystallization of sucrose during storage and distribution.
- "A" molasses produced after extracting 75% of the total recoverable sucrose.
- "B" molasses produced after some 85% of crystallizable sucrose has been recovered.
- "C" or final molasses considered as a by-product in view of the fact that further sucrose recuperation is not feasible.

Normally "A" and "B" molasses are not produced as products; they are re-processed in order to extract more sucrose. The chemical composition of the different types of molasses is essentially the same as the cane juice differing in that, as the technological flux to crystallization and sucrose separation advances, the biomass is submitted to alkali and steam treatments which increase the percentage of reducing sugars. In these processes, non-sugar organic substances are produced and concentrated. The other important difference between molasses and sugar cane juice is that the former has a high dry matter percentage (approximately 80%), which facilitates storage and distribution.

**Table 4.1. Chemical composition of different types of Cuban sugar cane molasses (Source: Figueroa and Ly, 1990).**

High-test	A	Molasses B	Final	
DM	85.0	77.8	78.1	83.5
(As % DM)				
Nitrogen	0.26	0.29	0.38	0.44
Ash	2.8	4.6	7.2	9.8
Total sugars	86.1	75.9	69.5	58.3
Sucrose	28.6	63.4	57.1	40.2
Glucose	29.3	6.4	5.2	8.9
Fructose	28.2	6.1	7.2	9.2
NFE	95.6	93.0	90.4	87.4
Non-identified OM*	9.5	17.1	20.9	29.1
Gross energy				
(MJ/kg DM) 15.0	14.9	14.7	13.5	

\* Nitrogen-free-extract minus total sugars

In Table 4.1 is the typical composition of the different types of molasses (High-test, "A", "B" and final). It should be noted that the concentration of total sugars decreases, and the ash and non-sugar organic matter increases, in the progression from high-test (concentrated, clarified, partially inverted cane juice) to final molasses. In a sugar cane mill where the efficiency of sucrose crystallization is low, the final molasses may resemble in composition the "B" molasses in Table 4.1. Molasses characterization is an essential step in deciding on the strategy for using it. In fact, it is precisely the composition of molasses which determines animal performance and which indicates whether it is best fed to monogastric or ruminant animals.

The different grades of molasses are essentially similar in their chemical composition. They contain sugars, nitrogenous substances and a "non-identified organic matter" fraction. This latter fraction varies significantly between the types of molasses. The other important characteristics of molasses are:

- It contains neither lipids nor fibre.
- The nitrogen content is low (<0.5%; about one third is in the form of free amino acids).
- The ash varies from approximately 3% (in dry matter) for high-test molasses to 10% for final molasses.
- The principal energetic source is a mixture of soluble sugars (as sucrose, fructose and glucose), the concentration of which increases from <58% in final molasses to 86% in high-test molasses.
- The proportion of total sugars to reducing sugar varies. It is less in high-test molasses due to a process of partial inversion to avoid sucrose crystallization.
- The gross energy of molasses is approximately 20% lower than that of any typical cereal grain.

The soluble fractions of sugar cane (juice and molasses) which are rich in energetic compounds are the feed resources which are finding increasing application in the feeding of pigs in the tropics. Their nutritive value in the pig diet will be determined by:

- Adequate protein supplementation.
- The efficiency with which the soluble sugars are utilized (sucrose, glucose and fructose).
- The mineral and vitamin content with the need to provide supplements to balance those in molasses.
- The role in digestion and metabolism played by the fraction of non-identified organic matter.

Typical results with growing-fattening pigs fed "C" (final), "B" or "high-test" molasses or a cereal grain control diet are given in Table 4.2. Growth rates on high test molasses were comparable with those obtained on cereal grain; results for the "B" molasses were slightly inferior and more so when "C" molasses was used. Feed intakes were always higher

on the molasses diets and therefore feed conversion rate was always poorer than with cereals. But this is not so critical when the price of molasses is less than that of grain.

**Table 4.2. Pig performance on high-test, "B" or final molasses compared with a maize/soya bean control; initial weight was 30 kg (Source: Figueroa and Ly, 1990).**

	Maize SBM	H-test	Molasses "B"	"C"
Final wt (kg)	104	103	98	96
LWt gain (g/d)	643	682	635	619
DM intake (kg/d)	2.21	2.55	2.61	2.56
DM conversion	3.19	3.74	4.11	4.14

Similar results have been obtained with molasses-based diets in pregnant and lactating pigs. In the case of lactating sows however, there are indications of better performance (more fat in the milk and better growth of piglets to weaning) on high-test molasses than on cereal grain (Table 4.3).

**Table 4.3: Performance of lactating sows fed high-test molasses and torula yeast (Source: Figueroa Vilda, 1991, personal communication)**

	Cereal	Molasses
Feed intake:		
Dry matter (kg/d)	4.1	4.5
ME (MJ/d)	56.0	53.8
Energy output in milk (MJ/d)	26.0	30.8
Litter weight (kg)*	58.5	63.2
Sow weight loss lactation (kg)	20.5	14.5

\* Weaning at 33 days; piglets fed sow's milk only

The differences between raw cane juice (high-test molasses is concentrated, partially inverted cane juice) and "B" and final molasses in trials done in Colombia (Figure 4.1) were much more pronounced. The poorer performance on the two sources of molasses possibly reflecting the advantages of higher purity cane juice (more sucrose, less reducing sugars) in Colombia (the industry is situated at 1000 m above

sea level and the difference in day and night temperatures maintains high sucrose content in the juice throughout the year) and higher factory extraction rates of sucrose, with correspondingly less sugar in the molasses.

**Figure 4.1. Comparison of sugar cane juice, and "B" and "C" molasses as basal diets for fattening pigs in Colombia (Source: Sarria *et al.*, 1990).**

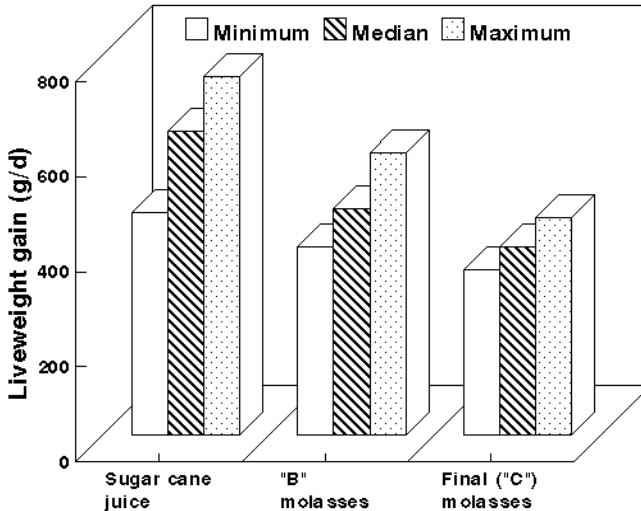

It is evident that the energy concentration and the nutritive value of the molasses are favoured as long as it is a major product (High-test, "A" and "B") and not simply a by-product (final molasses). But such "higher" grades of molasses compete with sugar production. In the traditional sugar industry which produces sucrose for local and preferential export markets, it will rarely be economical to produce high-test or "A" molasses but under some circumstances, it could be economically feasible to modify the normal industrial process to produce "B" molasses and "A" and "B" sugar. The economics of this will depend on the relative value of the "C" sugar for human use and of the "B" molasses for livestock feed.

### **Sugar cane juice**

The soluble fraction of sugar cane is easily extracted at farm level by passing the stalk through a "trapiche" or crusher. In these machines, the maximum extraction rate is between 60 and 80% (expressed as percent of total sugars extracted) equivalent to 40 to 53% of juice as a percentage of the weight of the cane stalk. In the industrial mill, with repeated washing and crushing (up to 5 times), extraction can be as high as 97% of the total sugars.

This soluble fraction, called "sugar cane juice" will contain from 16 to 23% of soluble solids (DM), mainly consisting of sucrose and reducing sugars. It is thus a liquid, energy-rich feed and difficult to conserve due to its rapid fermentation.

Sugar cane juice contains between 15 and 23% of total solids of which approximately 80% are soluble sugars, mainly sucrose. Sugar cane juice is not exposed to prolonged drastic alkali treatments and high temperatures (as is the case with molasses in the sugar factory). As a result the original chemical composition of the soluble sugars is preserved without the appearance of undesirable secondary chemical compounds, especially non-sugar polymers. Furthermore, there is no flocculation and extraction of the plant proteins as occurs during the clarification process in the sugar factory so the juice is richer in amino acids, minerals and vitamins than is molasses. The low solids content facilitates de-composition by a very rapid fermentation (8-12 hr), which can cause difficulties in the management and distribution of the cane juice in the piggery. The inclusion of formaldehyde, ammonium hydroxide or sodium benzoate permits the preservation of sugar cane juice for periods of from 3 to 7 days (Bobadilla and Preston, 1981). However, this has rarely been used in practice.

The research leading up to the development of this technology has been described by Mena (1989) and Sarria *et al.* (1990). The most important step was the demonstration that, when the protein was provided by soya bean meal, the levels could be reduced to 200 g/day with minimal effects on performance but important economic advantages (Mena, 1983; Sarria *et al.*, 1990).

Cane juice is now employed commercially as the basis of pig feeding on farms in Colombia (Sarria, 1994), Cuba (Perez, R., 1994, personal communication), Vietnam (Nguyen Thi Oanh, 1994) and Philippines

(Moog, F., 1994, unpublished data). Typical results on smallholder farms in a mountainous village in Vietnam are shown in Figure 4.2.

**Figure 4.2. Liveweight gains of growing-fattening pigs (local breed) on smallholder farms in Binh Dinh village in Vietnam. The protein supplement was 300 g/day of groundnut cake; minerals and vitamins were supplied from sweet potato vines and water plants (Source: SIDA-MSc, 1994).**

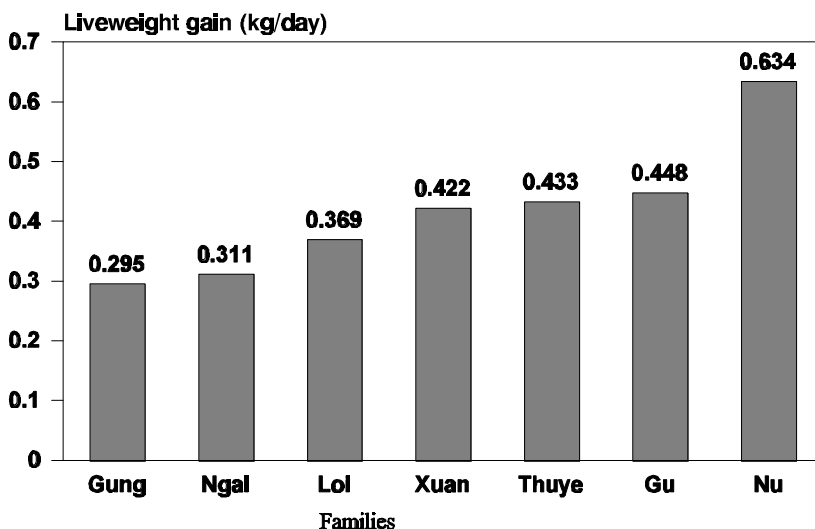

### THE SUGAR PALM AS A SOURCE OF FEED FOR PIGS

It is estimated there are about 1 million trees of sugar palm (*Borassus flabellifer*) in Cambodia where it is traditional practice to make palm sugar from the juice. The tree is also found in neighbouring countries: in Thailand, Vietnam, Myanmar, India and Bangladesh. The season of production of palm sugar is for 6 months (from December to June) and the rate of production (% of total/month) is 5, 15, 25, 30, 20, 5 for months 1 through 6. The juice is collected twice daily in the morning (about 2 litres) and again overnight (12-14 hr; 2.5 to 4 litres) from the flower of both male and female trees. It begins to invert quite quickly. Traditionally a piece of wood (popél) is used that produces an extract that slows down the inversion.



The juice contains about 13% of sucrose and production of "*masse cuite*" is on average 150g per litre of juice. Average yield is 4 litres juice/tree/day = 600 g of *masse cuite*. A serious constraint is the need for fuel. 1 kg of crude sugar (*masse cuite*) requires: 3-4.5 kg wood or 4.2- 5 kg of rice husks.

An average household in Cambodia will harvest the juice from 20 trees giving a total production in 180 days of 3600 kg. This is equivalent to a production of 1 kg of *masse cuite* per tree per day (peak time of the season).

Potential feed sources for pigs are the scums skimmed off the boiling juice. The scums are composed of the juice enriched with the proteins and minerals which flocculate and float to the surface due to denaturing of the protein when the juice is heated. From 20 trees, the daily production of scums from the evaporation of the palm juice is likely to be about 5 to 10 litres. This would supply the energy needs of 1 pig.

The fresh juice can also be used. The daily yield from two trees would be sufficient to feed one pig. There is increasing interest in Cambodia in this option due to the shortage and increasing price of firewood needed to make the sugar.

Results from a series of demonstrations in villages in Cambodia are shown in Figure 4.3. The juice was fed fresh and was supplemented with 300 daily of soya beans that had been boiled for 30 minutes after overnight soaking in water. Salt and green vegetable were also given.

Growth rates during the 4 months from January to April (days 0-91) were good (almost 500 g/day) when the palm juice was fed as the basal diet. From 91 to 152 days there was insufficient palm juice (end of the season) and the farmers used the traditional diet of rice bran. In almost all cases the growth rate decreased on the rice bran indicating the superior nutritional value of the palm juice diet.

**Figure 4.3. Liveweight gains of pigs fed sugar palm juice and boiled soya beans (0-91 days) and later (92-152 days) rice bran, on farms in villages in Cambodia (FAO/TCP, 1994b).**

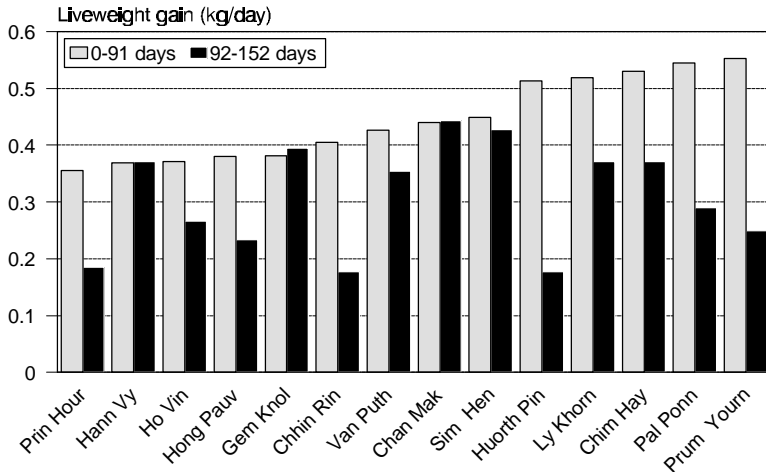

### THE AFRICAN OIL PALM AS THE BASIS OF INTENSIVE PIG PRODUCTION

The first attempts to use the products and by-products of the African oil palm (*Eleais guinensis*) in pig feeding were focussed on incorporating the dried sludge in relatively low concentrations in conventional mixed feeds (Ong, 1992). Ocampo *et al.* (1990a,b) were the first to show that the oil-pressed fibre (30% oil) could completely replace cereals in diets for growing-finishing pigs. These researchers subsequently extended their studies to the use of both the crude oil (Ocampo, 1994a), and the fresh fruit (Ocampo, 1994b), as complete replacements for cereal grain in all phases of the production cycle. The flow of biomass, products and by-products in a typical oil palm factory are shown in Figure 4.4.

**Figure 4.4. Flow diagram of African oil palm factory showing products and by-products (Source: Ocampo *et al.*, 1991a,b).**

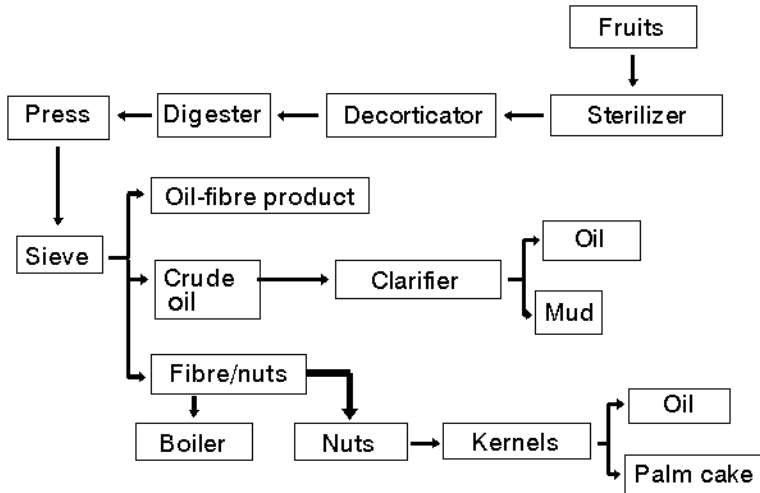

### The by-products

The three by-products of potential use in livestock production are:

- The oil-impregnated fibre (oil-press fibre) recovered after filtration of the crude oil.
- The mud which remains after the oil has been clarified and centrifuged.
- The palm kernel cake.

The first product has only 5% moisture, 24% of oil and 15% fibre (dry matter basis). In contrast, the mud contains over 90% moisture although the dry matter is rich in oil (51%) and relatively low in fibre (12%). Yields are 5 and 29% respectively of the weight of fresh fruit harvested. The palm kernel cake is relatively high in fibre and has only 20-25% protein. It has a limited role as a protein supplement for monogastric animals.

With a fruit yield of 15 tonnes/ha/yr (data for the Meta Department of Colombia; Ocampo, A., personal communication), the availability of the oil-press fibre and the mud is 0.76 and 0.44 tonnes dry matter equivalent/ ha/year, respectively. It has been demonstrated that:

- The oil-press fibre can be a complete replacement for cereal grain in the diet of the growing-finishing pig (Ocampo *et al.*, 1990a).
- There is no advantage of giving more than 200 g/day of supplementary protein (as soya bean meal) for fattening pigs in the range of 20 to 90 kg liveweight (Ocampo *et al.*, 1990b).

The effect of supplementary protein level on performance of pigs fed the oil-press fibre is shown in Table 4.4. With a dry matter intake of palm oil residue of 2.6 kg/animal/day, it takes 135 days to fatten a pig from 20 to 90 kg liveweight and uses 350 kg dry residue equivalent. Thus 1 ha of oil palm plantation should generate, on average, enough oil-rich residue (oil-press fibre and mud combined) that potentially could grow and finish 3 pigs. However, there are no reports on the use of the mud or "sludge" as the basis of the diet for pigs. This is an obvious area for further research.

**Table 4.4. Mean values for performance traits of pigs fattened with oil-press fibre and reduced levels of protein (Source: Ocampo *et al.*, 1990b).**

	Supplementary protein level (g/day)			
	280	256	230	200
Number days	121	126	124	135
Liveweight, kg				
Initial	22.7	22.8	22.8	22.1
Final	90.2	90.0	90.4	90.3
Daily gain	0.56	0.53	0.55	0.51
Intake, kg/day				
Soybean meal	0.70	0.64	0.57	0.50
Oil residue	2.33	2.44	2.22	2.56
Conversion (DM)	4.8	5.2	4.6	5.4

### Crude palm oil

The African oil palm has become an important crop in Colombia now established on approximately 120,000 ha of which 80% is currently in production. The recent (since 1993) removal of guaranteed producer-support prices, and the reduction of import tariffs in Colombia, led to a fall in the internal price of crude palm oil to close to the world free market price (about US\$450/tonne). This made the crude oil competitive on an energy basis with imported cereal grain (about US\$200/tonne), and was the stimulus for initiating research with the crude oil as the basis of

the diet of growing-fattening pigs (Ocampo, 1994a). An advantage from using oil as the energy resource is its high caloric density and the absence of fibre. This creates opportunities for using unconventional sources of protein such as tree leaves (Preston and Murgueitio, 1987) and water plants (Van Hove, 1986; Lumpkin and Pluckett, 1982; Becerra, 1991) whose fibre content would normally be a limitation in a conventional cereal grain diet.

The data in Table 4.5 show the effect of feeding a diet with 50% of the dry matter in the form of oil to growing-fattening pigs, and of replacing up to 30% of the soya bean meal protein with *Azolla filiculoides*. The results for growth and feed conversion suggest that, even at such high levels in the diet, the oil is efficiently utilized, and that there are apparently no detrimental effects on carcass quality.

**Table 4.5. Growth performance of pigs fed crude palm oil and different levels of *Azolla* replacing soya bean meal (Source: Ocampo, 1994a).**

	Replacement of soya protein by <i>Azolla</i> protein, %			
	0	10	20	30
Live weight (kg)				
Initial	28.8	29.4	28.8	28.9
Final	87.8	92.3	88.8	79.6
Daily gain	0.526	0.561	0.535	0.452
Feed intake, kg/day				
Supplement	0.500	0.450	0.400	0.350
<i>Azolla</i>	0.0	1.17	2.0	2.10
Oil	0.57	0.55	0.54	0.5
Rice polish	0.110	0.110	0.110	0.110
Total DM	1.11	1.10	1.0	1.0
Conversion DM	2.1	1.98	2.0	2.2
Carcass yield, %*	85	84	84	88
Backfat (cm)*	3.7	3.5	3.6	3.4

\*Means for 3 pigs per treatment obtained 1 hr after slaughter

The results also indicate that *Azolla* can replace successfully up to 20% of the soya bean protein in oil-based diets. Practical observations suggested that the presence of a small amount of carbohydrate (from rice polishings) in an oil-based diet was beneficial. A trial to evaluate the effect of level showed that there was no advantage in exceeding 100 g/day of rice polishings (Ocampo, 1994c, personal communication).

Several commercial producers in Colombia are now using the crude palm oil, supplemented with soya bean meal and rice polishings, as a replacement for cereals in all phases of the pig production cycle (Ocampo, 1994a; Ocampo, A., unpublished data; Rodriguez and Cuellar, 1994).

### Fresh oil palm fruit as the basis of pig diets

The use of the fresh whole fruit of the oil palm as the basis of intensive pig production makes it possible for the farmer-producer to diversify the end-uses of the crop through integration with pig production. This will have favourable effects on the sustainability of the farming system, since the manure from the pigs will serve as fertilizer for the trees. Farmer self-reliance will be increased by the creation of alternative end uses for the fruits thus reducing dependence on sale to the oil palm processing factories. The hypothesis that the pig would be able to extract the oil and other nutrients from the whole fruit was confirmed as can be seen from the data in Table 4.6. However, there was a reduction in growth rate, apparently related with a fall in intake, when the replacement of sorghum by the palm fruit exceeded 50%.

**Table 4.6: Performance of pigs fed whole fruit of oil palm as replacement for sorghum grain (Source: Ocampo, 1994b).**

	Replacement of sorghum, %			
	25	50	75	100
Duration trial, d	98	98	126	126
Liveweight, kg				
Initial	26.1	27.0	26.7	27.0
Final	89.3	85.7	90.2	85.7
Daily gain	0.625	0.596	0.503	0.466
Intake, kg/d				
Supplement	0.5	0.5	0.5	0.5
Sorghum	1.3	0.86	0.20	0.0
Palm fruit	0.54	0.97	1.68	1.59
Total DM	2.02	1.94	1.68	1.59
Conversion (DM)	3.2	3.2	3.3	3.4

Part of the reduced intake on the 100% fruit treatment was thought to be due to deterioration in fruit quality, when occasionally it had to be stored

for periods exceeding the recommended 7 days (Ocampo, 1994c, personal communication). Despite the slower growth rate, the economic analysis (under local conditions in the southern plains of Colombia) favoured the treatment with complete replacement of the sorghum by the palm fruit. This latter treatment would also be favoured by an analysis taking into account the indicators of sustainability.

### **SURPLUS AND REJECT BANANAS AND PLANTAINS**

In his review of bananas and plantains as animal feed, Batabunde (1992) pointed out that these would almost never be grown as a specialist crop for livestock, in view of their role as a staple in the human diet in most tropical countries. The exceptions to this rule are the commercial banana plantations producing fruit for export, where grading of the produce often results in rejections rates of 20-30% because of unsuitable characteristics (e.g., blemishes, over-size and over-ripeness). Many studies have been made on ways of using this material mainly for pig feeding. However, these rejects increasingly find their way into local markets and there are few instances of producers setting up livestock units to use these resources. The fruit of both plantains and bananas is largely composed of starch which gradually is converted to sugars during ripening. Because the fruits are low in protein (<4% in dry matter), the principle of the feeding system is the same as with sugar cane juice. A protein supplement is required but, as in the cane juice system, the amount can be restricted (see Chapter 3) to approximately 60% of the levels recommended by NRC (1988), assuming that the supplement chosen has a well-balanced array of essential amino acids. Ripe bananas generally support faster growth than green bananas (Hernandez and Maner, 1965), due it is believed to high "free" tannins in the unripe fruit. Cooking slightly improved the feeding value of the green bananas, but ensiling may be a more appropriate option (Le Dividich and Canope, 1975). The fact that there has been little research on bananas and plantains as animal feed during the past 20-30 years confirms Babatunde 's (1992) statement that these resources will almost always find a better market as human food.

Plantains are often grown as shade for coffee and, because of the

short shelf-life of the fruit and the distance from markets, their use as animal feed in these circumstances may be feasible (Espinal, R., 1993, personal communication). However, economic success will generally be obtained by minimizing costs rather than maximizing performance. Restricting the protein supply is an important strategy in this case.

## **CASSAVA**

Both the roots and the leaves can be used as feed for monogastric animals.

### **Cassava roots**

Processing (chopping and sun-drying) of the roots to produce cassava chips for animal feed is a major industry in several tropical countries, chiefly Thailand, Indonesia, Brazil and to a lesser extent in Colombia.

As with bananas and plantains, the decades of the 60's and 70's were the periods of active research into uses of cassava products in pig feeding when it was shown that fresh (the sweet varieties only), ensiled or dried cassava root chips could completely replace cereal grains in diets for pigs (see review by Gomez, 1992). Poultry appear to be less tolerant of cassava products, mainly because of the adverse effects of hydrocyanic acid (HCN) on intake and requirements for the sulphur-containing amino acids. Inclusion levels of dried root meal of less than 50% are recommended for broilers and no more than 40% in rations of layers (Khajarern and Khajarern, 1992).

The direction of the work eventually focussed almost exclusively on production of dried cassava root chips for export to Europe for mixed feed manufacture where, because they were classified as a by-product, they were subjected to a much lower tariff than imported cereal grain.

Some promising work on the feeding of fresh and ensiled cassava root chips, along with a protein supplement (Buitrago, 1964; Maner, 1972), a system that is appropriate for small-scale farmers, was unfortunately never followed up presumably because of the higher profits to be made in the short term from exports of the dried chips. The recent revision of the Common Agricultural Policy in the European Union and the consequences of the recently approved World Trade Agreement will almost certainly result in the market for cassava chips becoming less attractive. This will create opportunities for more sustainable mixed



farming systems in which the cassava will be consumed by livestock on the farm where it is grown.

There are indications that this approach is being adopted in the tropical region of Mexico (Lopez *et al.*, 1988; Rodriguez, 1989), using ensiling as the the method of conservation. Manipulation of the protein supply will be an important feature of research to popularize cassava feeding at the small farm level (Ospina *et al.* 1994). When livestock are treated primarily as components of farming systems and not as specialized activities, emphasis shifts to optimizing the role of the animal in the system rather than maximizing individual performance. This has important economic consequences since it is in striving for maximum performance that creates requirements for expensive ingredients such as essential amino acids and vitamins. An example of this interaction can be seen in the work of Ospina *et al.* (1994) where performance of growing finishing pigs on a basal diet of cassava root meal increased linearly with protein supply (from soya bean). The maximum biological response was obtained with a daily intake of 350 g protein, but the economic optimum was with levels of only 200 g/day.

The advantage of cassava is that it can be grown in areas with extended dry periods. Where there are better conditions for plant growth, other crops are usually more profitable as sources of animal feed (Nguyen Thi Mui, 1994a). Certainly, cassava is an exploitive crop and growing it in monoculture leads to declines in soil fertility. Thus it should be grown in rotation with other fertility-restoring crops, and this is usually what is practised by small-scale farmers (Moreno, 1992).

An attractive end-use for cassava is for manufacture of starch. This can be done at an artisan level with minimum infrastructure; chippers/grinders to peel and break up the roots into chips and a washing machine to extract the starch. A flow diagram for such a unit as operated in the Cauca Valley of Colombia is shown in Figure 4.5. The two by-products from this process are "bran" (*Afrecho*) and "fines" (*Mancha*). The bran contains (dry matter basis): 1% protein, 15% fibre and 60% starch; corresponding data for the fines are 5, 1 and 64%. As is to be expected, cassava bran and fines are low in protein and thus the total protein in the diet, provided it is well balanced in essential amino acids, can usually be reduced in accordance with the recommendations in Chapter 3. Typical results using these feed resources for growing-finishing pigs are given in Table 4.7.

Figure 4.5. Flow diagram of artisan system of producing starch from cassava roots showing origin of by-products (Espinel, R., unpublished data).

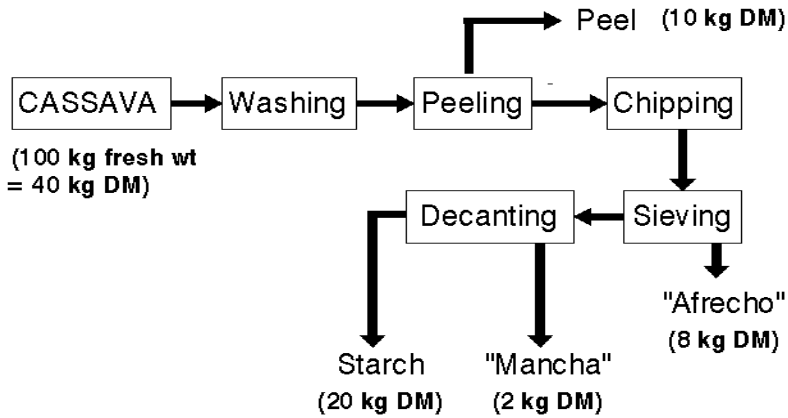

The results are similar to what would be expected with traditional diets of cereal grains. There is an obvious potential in cassava starch by-products as feed particularly for pigs. However, the way forward will be to encourage farmers close to the plants to engage in pig production. This will avoid the need for sun-drying the cassava by-products (a tedious, time-consuming exercise). The pig excreta could then be combined with the organic-matter-rich wash waters from the plant to feed biogas plants and ponds which in turn could provide fuel (the biogas) for the families and protein (from water plants grown on the ponds) to be recycled to the pigs.

**Table 4.7. Performance of pigs fed coarse and fine by-products from cassava processed for starch (Source: Ospina, L. and Espinel, R. 1992, Unpublished (data)).**

	Coarse	Fines (50:50)	Coarse:Fines
Liveweight (kg)			
Initial	38.5	41.5	38.1
Final	92.0	91.5	90.5
Daily gain	0.660	0.534	0.443
Feed intake (kg DM/d)			
Cassava by-product	2.1	2.04	1.75
Supplement	0.45	0.45	0.45
Total DM	2.55	2.49	2.20
Conversion	3.86	4.66	4.97

### Cassava leaves

When leaves are harvested at the same time as the roots, yields are in the range of 1 to 4 tonnes dry matter/ha (Ravindran, 1992). Leaf production can be enhanced by partial defoliation during the growing season. Ravindran and Rajaguru (1988) obtained almost 7 tonnes of leaf dry matter/ha by defoliating once during a 7-month growing season and reported a reduction in root yield of only 12%. It was claimed that, with adequate irrigation and fertilization, cassava cultivated only for leaf production will persist over several years with average annual dry matter yields of over 20 tonnes/ha (Montaldo, 1977). However, there are no reports of this practice being adopted by commercial farmers.

Fresh cassava leaves can be fed directly to ruminants but must be dried or ensiled for monogastric animals. The effects of drying and ensiling on the HCN content are shown in Table 4.8. Ensiling appears to be the best method for reducing HCN content. However, little is known about the effect of this process on the digestibility and availability of the amino acids. The nutritive value of the leaves is similar to that of alfalfa with respect to fibre levels and the amino acid profile (Figure 4.6).

**Figure 4.6. Amino acid profile of cassava leaf meal compared with optimum (Source: Ravindran, 1992; Wang and Fuller, 1989).**

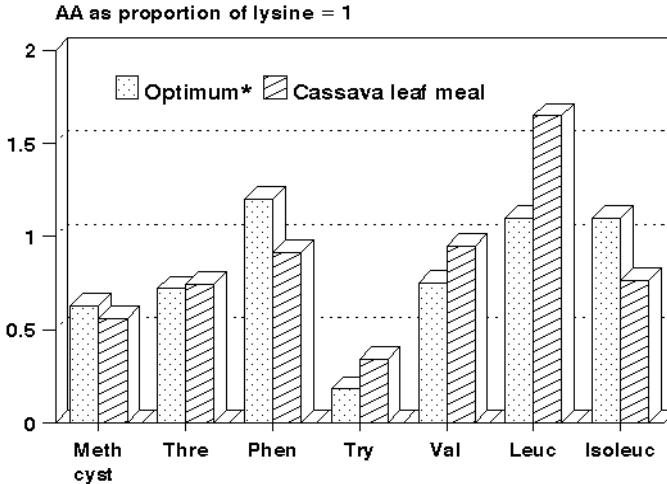

**Table 4.8. Effect of drying and ensiling cassava leaf meal on HCN content (Source: Bui Van Chinh, 1993, Unpublished data)**

	HCN (mg/kg DM)
Fresh	863
Dried in shade 2 days	274
Sun-dried for 4 hours	261
Sun-dried meal	80
Ensiled	33

### Sweet potatoes

An advantage of the sweet potato crop is its short growing season (100 to 150 days). Both the tubers and the vines are traditionally fed to pigs by small-scale farmers. There is evidence that cooking improves the feeding value of the tubers for pigs and especially poultry as it reduces trypsin inhibitors and improves starch digestibility (see review by Dominguez, 1992). As with other tropical carbohydrates sources, the economics of using sweet potato tubers in pig feeding will depend on the source and quantity of protein that is given. There appear to be no data

on growth responses to varying protein levels which makes this a priority area for research. Soya bean meal levels were reduced to 390 g/day (200 g/day of protein) when the fresh vines of sweet potato were also fed in a pig diet based on cooked sweet potato tubers (Table 4.9). However, little is known about the digestibility of the protein in the sweet potato vines.

**Table 4.9. Sweet potato vines as replacement for soya bean meal in diets based on cooked sweet potato tubers (Source: Dominguez, 1990).**

Intake, kg/d				
Soya bean meal	0.72	0.54	0.39	0.54
SP vines	0.0	2.4	5.1	0.0
Cooked SP9.5	8.6	8.1	0.0	
Maize	0.0	0.0	0.0	2.8
Liveweight gain, kg/d	0.77	0.69	0.64	0.77
Feed conversion (DM basis)	3.51	3.81	3.01	

## **PIG PRODUCTION SYSTEMS BASED ON RECYCLED HOUSEHOLD AND INDUSTRIAL ORGANIC WASTE**

Cuba developed an unconventional model for its national pig production strategy based on the integration of its principal agricultural crop - sugar cane - with the utilization of wastes and by-products from restaurants and canteens and from agricultural and industrial activities. In this way, the traditional dependence on cereal grains for the pig industry was avoided.

### **Collection and utilization of organic wastes**

All organic wastes with potential for use in pig feeding are collected and transformed into a liquid feed termed "processed wastes". The recovery of these materials is done systematically in tanker trucks which follow established routes throughout the country. In 1990, there were 205 such routes and the average amount of organic waste collected on each one was 7.7 tonnes, giving a total of 1,578 tonnes daily, or nearly half a million tonnes annually. The wastes are delivered to industrial plants designed specifically for the purpose of processing the wastes (Del Rio *et al.*, 1980), where they are submitted to selection, grinding, sterilization and mixing with sugar cane molasses, before being conveyed by pipeline

to pig fattening units (usually of some 12,000 head) situated adjacent (usually within 200m) to the processing plant (see Figure 7.2).

Analysis of this processed organic waste, prior to mixing it with molasses, shows that it contains: 13.5-18.8% dry matter, 7.9-16.7% ash, 18.6-22.2% protein, 6.6-10.8% lipids and 6.5-12.6% fibre (Dominguez, 1991).

The protein is highly digestible but low in biological value at 58% compared with casein at 91%. It appears that the sulphur amino acids - methionine and cystine - are the most lacking. In view of the relatively high level of protein in the processed wastes, it has been standard practice in Cuba to mix them with molasses, initially with final "C" molasses and more recently with molasses "B". Results obtained with different levels of the two types of molasses are summarized in Figure 4.7.

**Figure 4.7. Growth rates of pigs fed processed organic waste mixed with "B" or "C" molasses (Source: Dominguez, 1991).**

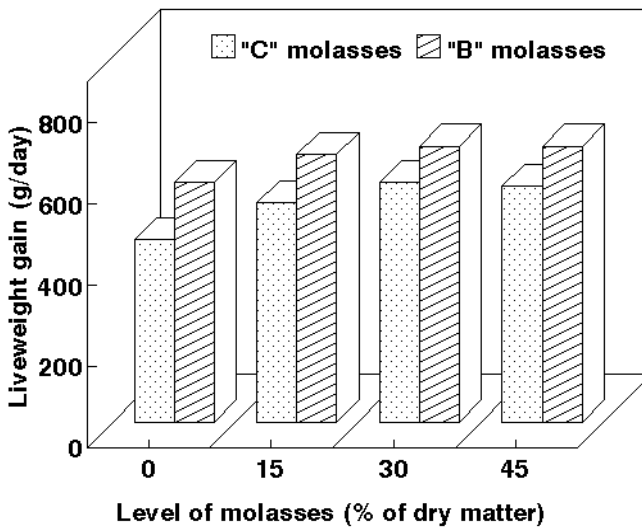

It is apparent that the optimum limit of either type of molasses is of the order of 30% (dry matter basis) and that performance is always better with "B" molasses.

It appeared that pig performance on the processed wastes was improved when supplements of minerals (including copper sulphate), vitamins and methionine were added. Liveweight gains in one trial were increased by more than 100 g daily by the supplements irrespective of the type of molasses used Dominguez (1991). However, this refinement never became commercial.

### **Incorporation of citrus wastes**

Ensiling citrus wastes following extraction of the juice has advantages over traditional drying, in that less energy is used (dehydration is usually with fossil fuel) and there are improvements in the palatability, probably due to destruction of certain secondary plant compounds which give a bitter taste to both the dried and fresh product (Dominguez, P., personal communication).

Results from using ensiled orange wastes as a replacement for final "C" molasses are shown in Table 4.10. Liveweight gains were unchanged but feed conversion was improved when the citrus silage replaced the final molasses. These results show that the organic wastes from the citrus industry can be incorporated satisfactorily with other processed organic wastes for pig production, and can replace molasses.

**Table 4.10. Performance of fattening pigs given a basal diet of processed organic wastes and different proportions of final molasses and ensiled citrus pulp (Source: Dominguez, 1991).**

Ensiled orange waste	0	12	25	40	
Final molasses		49	37	24	9
Dry matter intake (kg/d)	2.8	2.9	2.6	2.45	
Weight gain (kg/d)		0.62	0.62	0.59	0.60
Feed conversion		4.54	4.64	4.37	4.08

### **Thermal destruction of animal and vegetable wastes**

Another feature of the Cuban programme of waste utilization has been

the design and development of an autoclave with mechanical agitation which processes adequately (130°C and 2 atmospheres pressure) not only vegetable wastes but also wastes from abattoirs and even dead animals. The advantage of this system compared with dehydration is the saving in fuel oil (3.7 tonnes less oil are used in wet processing compared with dehydration) and the lower investment cost of the equipment.

Conservation of the paste-like product has not proved to be a problem since addition of molasses has proved to be both effective and convenient. In any event the molasses is usually added to the final mixture of processed wastes. It is planned to equip all new waste processing units with the thermal-disintegrator system (Dominguez, P., personal communication) in view of lower investment costs and simpler operating procedures.

### **Conclusions**

The Cuban experience is unique in that it has shown that there can be an economical and ecological solution to the problem of organic waste disposal that is particularly appropriate for developing countries. The benefits of recycling organic waste as feed are many:

- In comparison with sanitary (?) land fills there is almost no production of methane and no risk of contaminating ground waters.
- The economic return from recycling the waste as feed is much greater than converting it into compost.
- Organic waste because of its high moisture content is not a suitable candidate for use as fuel in thermoelectric stations.
- If the wastes from the livestock units are themselves recycled through biodigesters and ponds, and sustainability indicators are applied, the overall balance will favour much more the recycling system, compared with any other method of disposal.

The constraints on the system are the dependence on fossil fuel for the vehicles required for the collection and transport of the raw material. On the other hand, this material has to be disposed of in one way or another, and it can be argued that the extra costs of delivering the organic waste to processing centres is justified by the saving in resources and the reduction in environmental contamination.



## ENSILED ANIMAL AND FISH WASTES

The ensiling of the animal and fish by-products, using molasses and crude syrups derived from sugar cane, is a simple and appropriate method of conservation (Perez, R., personal communication). The results of using this method to preserve mixtures of blood and shrimp heads in Vietnam are shown in Table 4.11. The shrimp heads were mixed with blood and molasses in the ratio (wet basis) of 5:3:2 and ensiled for 3 weeks. The pH fell to 4.5 at the end of the first week and remained at this level for the remainder of the ensiling period. The silage was used to replace fish meal at levels of 5 and 10% (diet dry matter basis) in a diet based on maize and rice bran in a fattening diet for pigs.

There were indications that the palatability of the silage was a constraint affecting intake and feed conversion at the 10% replacement level. It would be interesting to test the silage in completely mixed diets based on molasses or juice from sugar cane or sugar palm.

**Table 4.11. Mean values for growth and feed conversion of pigs fed silage of shrimp heads, blood and molasses as replacement for fish meal in cereal-based diets.**

		Control	Silage, %		SE
			5	10	
Liveweight, kg					
Initial	23.4	24.5	24.1		±9.4
Final	74.8	79.0	75.8		±2.6
Days on trial	102	100	107		±2.0
Liveweight gain, g/day					
Actual		506	532	483	±11
Adjusted*		502	531	489	±4.1
Dry matter intake, kg		1.93	1.92	1.80	±0.04
Dry matter conversion					
Actual		3.32	3.60	3.64	±0.21
Adjusted*		3.08	3.54	3.93	±0.052

\* By covariance for differences in initial weight and days on trial

## SUGAR CANE DERIVATIVES FOR POULTRY

### The general approach

Research in Cuba twenty years ago showed that raw sugar could replace the cereal grain in diets for all classes of poultry (Perez *et al.* 1968). However, the technology never became truly commercial. Raw sugar is

almost always too expensive to use in animal feeds. Molasses and cane juice are economically competitive with cereals but there are many factors that mitigate against their use for fattening and laying birds other than water fowl. For example:

- Large scale poultry systems are designed to use complete mixed and dry diets.
- The productive life of broilers is too short to permit them to adapt adequately to liquid diets.
- The mouth parts of birds are not designed for consuming liquid feeds. There is considerable wastage (whether it is cane juice or molasses) and the feed sticks to the plumage which is an inducement for cannibalism.

## LAYING AND FATTENING HENS

### Sugar cane juice

Use of the cane juice as a substitute for grain in broiler and laying hen diets has not been successful due mainly to the physical difficulties experienced by chickens in consuming a low-density liquid diet, and the stress caused by splashing of the sugar-rich juice on the feathers which can lead to cannibalism. Rates of growth and feed conversion have rarely exceeded 60-70% of genetic potential (Arango *et al.*, 1994).

Laying hens, particularly the heavier dual purpose strains, which have been raised on cane juice, have been maintained through complete laying cycles with satisfactory, although lower, egg production (about 65% laying rate) than would be expected with cereal diets (Vargas, J., unpublished data).

### Molasses

An interesting development has been reported from Cuba (Rodriguez *et al.*, 1994). It was found that ground sun-dried tropical forages, especially the leaves of sugar cane, were able to absorb up to twice their weight of "B" molasses. The molasses is first diluted with 20% of its weight of water, then mixed with the dry leaf meal and the mixture left to dry in the sun for 48 hr. The final product contains (DM basis): 70% "B" molasses and 30% dried sugar cane leaf meal. It is friable and easily mixed with

other dry ingredients. Its true metabolizable energy value was found to be 2.87 Mcal/kg DM. Up to 40% of this feed has been included in diets of laying hens with no loss of performance. The aim now is to replace the whole of the cereal grain with this alternative tropical feed resource.

## DUCKS AND GEESE

Recent developments in the feeding of cane juice to ducks are much more promising (Bui Xuan Men and Vuong Van Su, 1992; Becerra *et al.*, 1994). Ducks are well adapted to consuming liquid diets and, provided they have access to water for swimming, have no problems with the sugar juice falling on their plumage. It appears to be possible to reach at least 80-90% of genetic potential for growth (Figure 4.8).

**Figure 4.8. Ducks can be fattened on sugar cane juice with growth rates only slightly less than on cereal grain. (Source: Bui Xuan Men and Su Vuong Van, 1992).**

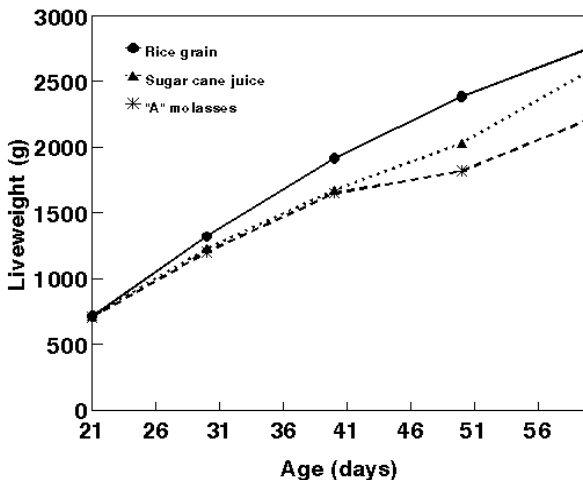

As with pigs, the absence of fibre in the cane juice permits partial substitution of conventional protein sources with water plants such as *Azolla filiculoides* (Becerra *et al.*, 1994). There appears to be real

potential here to develop low-cost, farm-based commercial feeding systems.

### **OTHER TROPICAL NON-CEREAL FEED RESOURCES FOR POULTRY**

Reject (from human consumption) cassava roots, sweet potato tubers and banana and plantain fruits, have long been fed to poultry managed as scavengers around the farm holding. There appears to be no reported research on the use of these feed resources as the basis of the diet in intensive on-farm feeding systems.

Scavenging for their feed continues to be the predominant system in the less-developed tropical countries. Nutritional improvements to this system have not been researched very well as it has not been a priority for most NARIs and not all for the CGIAR centres. In contrast, from the sociological standpoint, poultry are the most widely owned species of livestock and are particularly important for income generation for women.

There are reports from Bangladesh of economic gains by supplementing scavenging chickens with 25g of by-product feeds such as rice polishings (Dolberg, F., personal communication). It is likely that the choice of supplement will depend on the human and livestock pressure on available natural resources. Where pressure is high, protein is likely to be the first limiting factor as was shown in a study in Bangladesh where the contents of the crops of birds and ducks were found to have in the region of 9-10% crude protein in dry matter (Huque and Asaduzzaman, 1990). Where human and animal pressure is low, there may well be benefits from an energy-rich supplement. All of these observations indicate that there is need for much more research in this area.

### **TROPICAL NON-CEREAL FEED RESOURCES FOR RABBITS**

#### **Sugar cane**

The digestive system of rabbits requires that they be fed preformed amino acids (protein) that should preferentially be released in the small intestine. Although most non-ruminant small herbivores practise coprophagy, it is not efficient for protein to be recycled in this way since the pathway involves first fermentation to microbial protein. On the other hand the practice does permit cell wall carbohydrates to contribute

energy as volatile fatty acids. Rabbits also like to use their teeth to bite and chew their feed. The two approaches to replacement of cereal grains by sugar cane products which promise to have impact in farm practice are:

- Use of molasses incorporated into solid blocks along with other by-products.
- Use of sugar cane juice as an integral component of the fresh sugar cane stalk.

### **Molasses**

The idea of preparing molasses-rich solid blocks for rabbits was first proposed by Perez (Perez, R., personal communication). It was further developed in Vietnam (Dinh van Binh *et al.*, 1991), where it was shown that adequate growth and reproductive rates could be obtained with blocks containing 50% final molasses. In one trial, urea was incorporated at low levels (4%) but had no apparent effect. More recently in Colombia (Espinal, R., unpublished data), blocks made with 30% of final molasses and complemented with legume bean foliage have supported growth rates post weaning of 20 g/day. This is comparable with what can be achieved in the tropics with pelleted complete diets based on cereal grains.

### **Sugar cane juice and fresh "split" stalk**

Early attempts to replace cereal grains with sugar cane juice showed that it was technically feasible to adapt rabbits to consume liquid cane juice (from the same type of bottle used to dispense the drinking water), but growth rates were well below the genetic potential of the animals. More promising results have been obtained in Vietnam using lightly peeled cane stalk split down the middle (Nguyen Quang Suc *et al.*, 1994).

The rabbits relished the peeled, split cane stalk which was cut into lengths of about 15cm. For fattening of young rabbits, growth and feed conversion were best on the sugar cane stalk (Table 4.12). Reproductive performance was the same with the peeled sugar stalk as with the control fed cereal-based concentrates (Table 4.13). Feed costs were less for the sugar cane diet in both trials. It has since been found that peeling of the stalk is not necessary and it is enough simply to cut into short lengths and split these longitudinally (Nguyen Quang Suc and Perez, R., unpublished observations).

**Table 4.12. Mean values for performance of fattening rabbits fed concentrates or peeled sugar cane stalk (Source: Nguyen Suc *et al.*, 1994).**

	Concentrates	Sugar cane
Number of rabbits	20	20
Liveweight (g)		
Initial	459±41	468±53
Final	770±70	873±178
Daily gain	11.2	17.1
Feed intake (g/day)		
Concentrate	36.2	
Grass	124	
Peeled sugar cane stalk		91.9
Soya bean seed		23.9
Legume bean foliage		68.7
Total dry matter	53.6	62.9
Feed conversion	4.85	3.75

**Table 4.14. Mean values for reproductive performance of New Zealand White rabbits fed peeled sugar cane stalk, toasted soya bean seed and legume bean foliage (Source: Nguyen Quang Suc *et al.*, 1994).**

	Concentrate	Sugar cane
Number of does	9	10
Body weight change during lactation (kg)	-0.20	-0.31
Litter size at birth	5.4	5.1
Offspring weight (g)		
Birth	52.4	48.6
21 days	204	192
Feed intake (g/doe/day)		
Concentrate	94.1	
Guinea grass	548	
Sugar cane stalk		276
Soya bean seed		23.7
Legume bean foliage		421
Total dry matter	214	270
Total; N*6.25	17.3	19

## Chapter 5

## Nutrition of ruminants

*Developing production systems for ruminants using tropical feed resources requires an understanding of the relative roles and nutrient needs of the two-compartment system represented by the symbiotic relationship between rumen micro-organisms and the host animal. Fibre-rich, low-protein forages and crop residues are the most abundant and appropriate feeds for ruminants in the tropics. Strategies to improve the utilization of these feeds should aim: (i) to provide supplements to correct the nutrient imbalances at the level of the microbes and the animal and; (ii) to increase the availability of energy to rumen microbes by "high-offer" (selective) feeding or chemical treatment (usually with urea).*

*The most limiting nutrients for rumen microbes are ammonia, sulphur and phosphorus. For the animal, the needs for supplements are determined by the rate of production (e.g., of work, of growth, of milk) and reproduction, and mostly involve the supply of "by-pass" (or "escape") protein.*

### GENERAL CONSIDERATIONS

#### Introduction

In order to develop feeding systems, it is necessary to relate information on the nutritional characteristics of feed resources to the requirements for nutrients, depending on the purpose and rate of productivity of the animals in question. In the industrialized countries, this information has been incorporated in tables of "feeding standards" which interpret chemical analyses of feed resources in terms of their capacity to supply the energy, amino acids, vitamins and minerals required for the particular productive purpose. These standards are steadily becoming more sophisticated with the aim of improving their effectiveness in predicting rates of performance of intensively-fed livestock and to derive least cost formulations.

**Limitations to "conventional" feeding standards**

The relevance of feeding standards for developing countries, particularly those in the tropics, has been questioned from the socio-economic (Jackson, 1980) and technical (Graham, 1983; Preston, 1983) viewpoints. It has been apparent for many years that feeding standards based on assigned nutritive values (e.g., net energy) are misleading when un-conventional feed resources are used (e.g., Preston, 1972; Leng and Preston, 1976), since the levels of production achieved may be considerably less than the level predicted. More importantly, this often led to the rejection of many available feed resources which apparently were too low in digestible energy to supply the energy needed for production. It also encouraged researchers to copy feeding systems used in temperate countries, which are relatively "predictable" but which require feed resources that are unavailable and/or inappropriate on socio-economic grounds in most developing countries.

**An alternative approach**

The justification for a new approach to the development of feeding systems for ruminants, not based on conventional "feeding standards", is that:

- The efficiency of the rumen ecosystem cannot be characterized by any form of feed analysis.
- Feed intake on some diets bears no relationship to digestibility and is much more influenced by supplementation.
- Availability of amino acids cannot be inferred from the crude protein content of the diet.
- The energy value of a diet, and the efficiency of its utilization, are largely determined by the relative balances of glucogenic energy, long chain fatty acids and essential amino acids absorbed by the animal.

In the early 1960's, Professor Max Kleiber had expressed a similar concern for these issues and stated (as quoted by Kronfeld, 1982) "...metabolizable energy is not a homogeneous entity; instead it represents an assembly of nutrients or metabolites each of which is used with a specific efficiency for a particular purpose". To this could be added that the availability of these nutrients, and their interactions, affect the efficiency of energy utilization.



The misconceptions inherent in any system based primarily on feed analysis are that it is almost impossible to predict:

- Whether the feed can support efficient rumen function.
- The nature, amounts and the proportions of the end products of fermentative digestion.
- The potential for rumen escape of nutrients and their digestibility in the small intestine.

For these technical reasons, and also because of differing socio-economic circumstances, it has been proposed that a more appropriate objective, especially for developing countries, is to "match livestock production systems with the resources available" (Preston and Leng, 1987).

This chapter sets out the guidelines for applying these concepts to the development of feeding systems which aim to optimize the utilization of locally available feed resources and to build on traditional practices.

### **Animal response to non-conventional feed resources**

It is relevant to point out that the doubts concerning the usefulness of feeding standards for ruminants in tropical countries surfaced during development work in Cuba (Preston and Willis, 1974) in the 70's when livestock production systems were being established on non-conventional feed resources (i.e., molasses-based diets). In these cases, although nutrient requirements were satisfied according to traditional feeding standards, the responses of the animals did not correspond to the predicted levels of performance. This research demonstrated that small inputs of "by-pass protein" (Peruvian fishmeal) dramatically increased growth rate and feed efficiency of cattle (Figure 5.1). In contrast, this feeding system was not able to support high levels of milk production (Figure 5.2), presumably because of the greater demands in lactation for glucogenic compounds and the relative deficiencies of these in the digestion end-products on molasses-based diets, in turn caused by the low- propionate, high-butyrate fermentation in the rumen (Marty and Preston, 1970).

Figure 5.1. Effect of replacing urea with fish meal on performance of steers fed a basal diet of molasses-urea (Source: Preston and Willis, 1974).

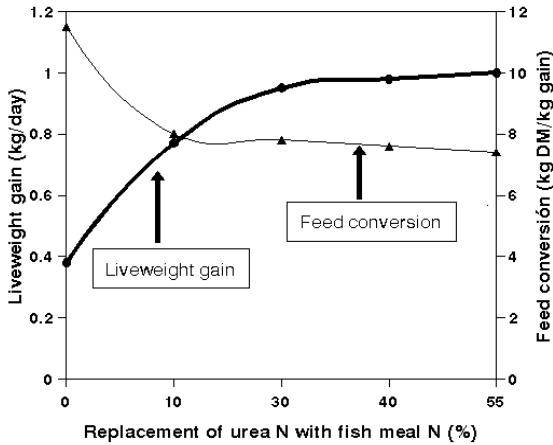
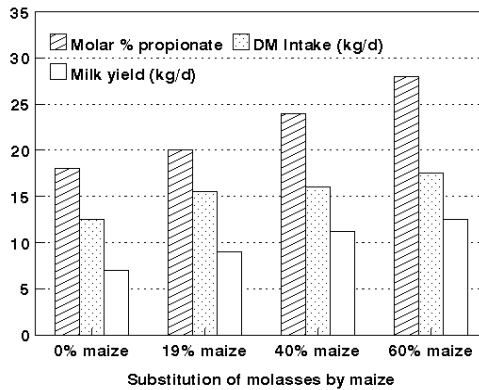

Figure 5.2. Replacing molasses with maize grain as basis of diet of dairy cows increased rumen propionate, dry matter intake and milk yield (Clark *et al.*, 1972).



The high potential yield of animal products from a hectare of sugar cane stimulated the subsequent research in Mexico, Mauritius and the Dominican Republic that attempted to establish cattle production systems, applying the principles developed for feeding molasses (both feed resources had similar concentrations of soluble sugars) (see Preston and Leng, 1978a,b). Research on the feeding value of derinded and chopped sugar cane (Preston *et al.*, 1976) demonstrated that:

- Feed intake was low even though digestibility was high (60-70%)
- The animals on this feed apparently needed glucose or glucose precursors because all the sugars are fermented, rumen propionate levels are no higher than observed on high-fibre diets, and the presence of a dense population of ciliate protozoa (Valdez *et al.*, 1977) reduced the availability of microbial protein to the animal (Bird and Leng, 1984).

The implication of these two findings is that rumen function did not provide the required balance of nutrients for productive purposes (see Leng and Preston, 1976). Recognition of the role of fermentable N and by-pass protein in low-N diets led to research aimed at increasing productivity of cattle and sheep on a range of high fibre and sugar-rich low-N feeds (Leng *et al.*, 1977; Preston and Leng, 1984, 1987). Prior to this work, these feed resources were considered to have little value other than to support maintenance and were universally referred to as "low quality" fibrous feeds. This led to attempts to improve the digestibility of fibrous feeds by, in particular, alkali treatment (Jackson, 1977, 1978).

However, the value of alkali treatment was partially obscured by the failure to recognize that the first limitation was not digestibility but the imbalance of nutrients at the level of both the rumen and the whole animal (Preston and Leng, 1987). Combining alkali treatment (ammonia) and appropriate supplementation has finally led to a very extensive programme of straw-based feeding systems being applied on farms in China (Dolberg *et al.*, 1994). The significance of this development is the magnitude of the contribution of straw to the total dietary dry matter and achievement of high rates of liveweight gain once thought to be the prerogative of cereal grain feeding.

**Nutritive value**

In order that responses in animal productivity to supplements can be predicted accurately on a particular diet, it is necessary to take account of the constraints to metabolism. These relate specifically to the relative amounts of amino acids, glucogenic energy, VFA energy and long chain fatty acid energy in the end products of fermentative and intestinal digestion, since this is what determines the animal's productivity. Productivity of ruminants is influenced primarily by feed intake which, in turn, is determined by feed digestibility and the capacity of the diet to supply the correct balance of nutrients required by animals in different productive states. Therefore the two major variables that need to be considered are:

- The amounts and balance of nutrients required.
- The quantitative availability of nutrients from the diet.

The balance of nutrients required depends upon:

- The amounts of dietary components unchanged by rumen fermentation that are absorbed (amino acids, glucose and long chain fatty acids).
- The rates of production of the end products of fermentative digestion (which can be highly variable).
- The productive functions (pregnancy, lactation, growth, work, maintenance, depletion or repletion of bodyweight).
- The environmental factors (disease, parasitism, temperature and humidity, and other sources of stress).

The availability of nutrients from a diet is highly dependent on:

- The microbial ecosystem in the rumen which influences the availability of microbial protein, VFA energy and glucogenic energy.
- The chemical composition and physical form of the diet which influence the amounts of protein, starch and long chain fatty acids which escape the rumen fermentation.

At the present time, it is not possible to predict the nutrients required by ruminant livestock and to match these with nutrients available from digestion, because of the many interactions between the animal, its rumen

microbial ecosystem and the diet. The most widely available low-cost feeds for ruminants in the majority of developing countries are usually native pastures, crop residues and to a lesser extent agro-industrial by-products. The expensive, and often unavailable (or exported), feeds are the protein meals, derived from oilseed residues and the processing of animals, fish and cereal grains.

Generally, energy (the basic feed resource) and fermentable nitrogen (urea) are relatively inexpensive ingredients, while the sources of amino acids and glucogenic compounds (the protein meals, cereal grains and cereal by-products) are very expensive. Since it is fermentation of carbohydrate which provides the energy for microbial growth, and as the feed is often low in digestibility, it is generally desirable to supply fermentable energy on an *ad libitum* basis. The basal diet should not therefore be restricted.

As a rule of thumb, 3 g of fermentable N per 100 g of fermentable organic matter are required to meet the needs for efficient microbial growth. It is not always necessary to provide this amount since some feed protein will be fermented to ammonia and some urea-N may enter the rumen in saliva. These processes reduce the amount of non-protein nitrogen needed. In addition there is evidence that the rumen microbes need small amounts of amino acids and other nutrients for efficient microbial growth. The potential of the diet to satisfy the requirements of the animal for amino acids, glucogenic precursors and long chain fatty acids depends on the pattern of fermentation and on the dietary protein, lipids (or their constituent fatty acids) and starch that escape fermentation and are digested in the intestines.

The extent to which the protein in a supplement escapes the rumen is partly a function of its rate of degradation (solubility) in the rumen. It is likely to be influenced greatly by the rate of flow of fluid and small particles out of the rumen. This latter characteristic will be influenced by processing of the feed (by physical or chemical means), the presence of some green forage, the amount of protein reaching the duodenum and external factors such as temperature and exercise/work.

The same factors will influence the supply of glucose and glucogenic precursors in terms of the likely by-pass of starch to the duodenum. However, the nature of rumen fermentation will have a major influence in terms of the supply of propionic acid for glucose synthesis.

## RELATING NUTRIENT SUPPLY TO PRODUCTIVE STATE

### Introduction

There is insufficient information available to permit the precise quantification of the proportions of the different nutrients required for different productive states. Nevertheless, an approximation of the needs of animals can be attempted. The suggested scheme attaches relative priorities to the groups of nutrients according to the physiological and biochemical processes underlying the expression of the particular productive state (see Figure 5.3).

The groups of nutrients to be varied for different productive states are:

- VFA energy.
- Glucogenic energy.
- Amino acids.
- Long chain fatty acids (LCFA).

Figure 5.3. Metabolic substrates and productive function (Source: Preston and Leng, 1987).

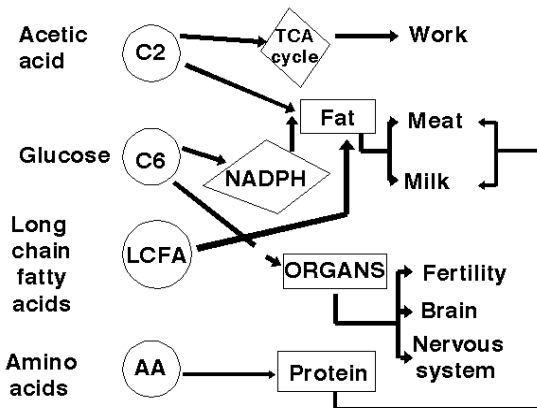

The sources of these nutrients are summarized in Figure 5.4. VFA energy arises from the rumen fermentation of all types of organic matter principally carbohydrates. The principal way of increasing VFA energy

in a particular feed is to increase intake (e.g., by selection through high offer level), to increase the rumen degradability (urea supplement), to supplement with by-pass protein or to treat with alkali (ammoniation).

**Figure 5.4. Sources of nutrients for metabolism (Source: Preston and Leng, 1987).**

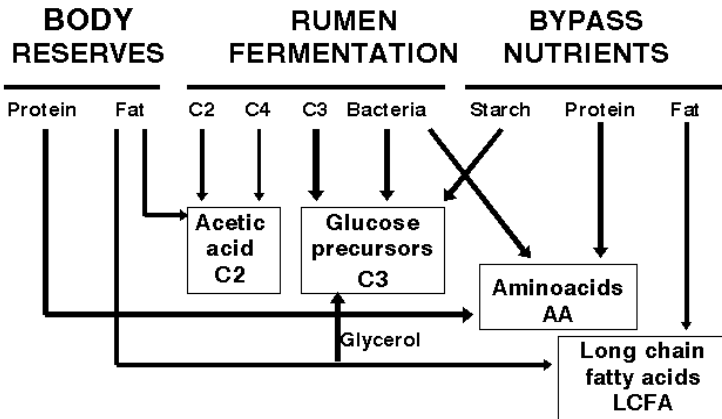

Manipulation of the rumen to provide extra protein and glucogenic precursors is still at the experimental stage. Dietary supplementation is the most obvious way of manipulating the supply of absorbed amino acids, glucose and glucose precursors.

Most supplements are expensive and their use in ruminant nutrition competes with monogastric animal and human nutrition. If the primary feed resource is a product of low nutritive value which would have been wasted if it were not fed to ruminants, it can be argued that the ruminant uses these concentrate supplements more efficiently than monogastric animals. For this reason, the term "catalytic" supplement has been used to describe these effects (Preston and Leng, 1987). Sucked milk, given in small amounts (<2 litres daily) as a supplement for calves given a straw- or molasses-based diet, is a good example of a "catalytic" supplement.

It is mandatory that research should produce response relationships to distinguish economic from biological optima. As a rule of thumb, the role of the supplement ceases to be "catalytic" when it exceeds about 30% of the diet dry matter. Beyond this point it assumes a major role and substitution occurs. The productive functions and the need for supplementary nutrients are discussed in order of the least to the most demanding.

### **Work**

Work requires ATP (adenosine triphosphate) generated from the oxidation of long-chain fatty acids, with obligatory requirements for glucogenic compounds and for amino acids (to repair the wear and tear of tissues and replace protein secretions) (see Leng, 1985). The working animal can often obtain sufficient nutrients from a nitrogen-deficient diet so long as it balances the protein:energy ratio needed for tissue turnover by "burning" off acetate which is in excess of requirements. However, body weight loss may restrict the period of work. If the work period is to be prolonged and weight loss is to be minimized, then the nutrients available must be balanced so as to satisfy the needs of the working animal. The digestibility and the intake of the basal diet may also have to be increased by supplementing with urea to correct a deficiency of fermentable nitrogen in the rumen. This may be the only manipulation necessary, but supplements rich in fat and by-pass protein could be beneficial particularly where the animal is in a productive state (e.g., pregnant or lactating). If weight loss continues because work is prolonged, it may be necessary to increase the degradability of the basal diet, for instance by ammoniation (urea treatment).

The mature, unproductive ruminant does not appear to require nutrients over and above those provided by an efficient fermentative digestion. Since the heavily working animal uses largely long chain fatty acids and glucose (Pethick and Lindsay, 1982; Leng, 1985), the supplements used should contain or provide these substrates. This is particularly important in the case of long chain fatty acids, since their absorption and use for fat deposition or mobilization and for work will be much more efficient and will require less glucose oxidation than fat synthesis from acetate and subsequent utilization in muscle metabolism.



## Maintenance

Maintenance alone obviously requires less energy expenditure than work so there is a proportionately higher demand for amino acids (relative to energy) than in the working animal. This will always be provided by a rumen system which is adequate in fermentable nitrogen. Animals in negative energy balance for an extended period on low-nitrogen roughage-based diets extract more digestible energy from the basal diet when this is supplemented with fermentable nitrogen (see Table 5.1).

**Table 5.1. Liveweight change of pregnant cows and calf birthweights in response to supplements providing fermentable nitrogen and sulphur alone or with by-pass protein (Source: Lindsay *et al.*, 1982).**

		Hay intake (kg DM/d)	Live weight change (kg/d)	Birth weight of calf (kg)
Spear grass	4.2	-0.81	22	
Spear grass+urea+S		6.2	-0.31	31
Spear grass+urea/S+ by-pass protein*		8.1	+0.75	32

\* 1 kg/d of protein pellet (80% cottonseed meal, 10% fish meal, 10% meat meal)

## Growth

Growing animals have a very high requirement for amino acids for tissue synthesis and glucose for oxidation in specific tissues (e.g., brain). In addition, considerable amounts of glucose must be oxidized to provide the NADPH required to synthesise fat from acetate. It is imperative to recognize that high growth rates cannot be supported on the products of fermentative digestion and that by-pass protein supplements are essential to take advantage of the VFA energy absorbed.

Many factors influence the level of protein supplementation to be used. Response relationships must be established which relate protein supply to animal productivity for each basal (carbohydrate) resource and for the available protein sources. The response pattern will vary according to the nature of the basal diet and the particular protein supplement. Data taken from Bangladesh and Cuba demonstrate this rationale.

Cattle on ammoniated (urea-treated) rice straw, when supplemented with only 50 g/d fish meal, increased their liveweight gain threefold (Figure 5.5). On a molasses-based diet of higher energetic potential, 450

g/d of fishmeal were needed to raise liveweight gain from 300 to 900 g/day (Figure 5.1).

**Figure 5.5. Adding small amounts of a by-pass protein (fish meal) to a basal diet of ammoniated (urea ensiling) rice straw dramatically increases gain in live and carcass weight (Source: Saadullah, 1984).**

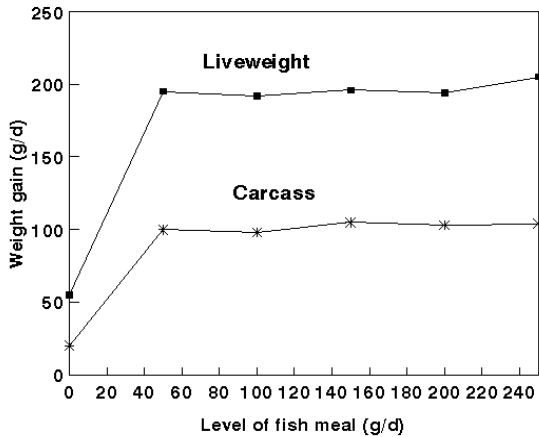

## Reproduction

Improvements in fertility brought about through nutrition are usually attributed to increased energy intake. There is, however, information to show that the supply of glucogenic precursors relative to total energy is an important feature of the improved energy status which results in increased fertility.

### *Conception and puberty*

Recent studies have demonstrated that even when the protein supply is adequate, the "quality" of the energy can also be a limiting factor. At the same metabolizable energy intake (the basal diet was low-N Coastal Bermuda grass pasture), puberty was reached at lower liveweights when glucose availability in the animal was enhanced by supplementation with monensin (Table 5.2). This is not a recommended practice but serves to demonstrate the concept. There are, of course, ways of increasing the

glucogenic potential of the absorbed nutrients without recourse to chemical additives (e.g., by the use of by-pass protein).

**Table 5.2. Increasing rumen propionate production (by feeding monensin) in heifers fed grass hay increased fertility as evidenced by greater proportion of heifers cycling at end of test period (Source: Mosely *et al.*, 1982).**

	Control	Monensin
Liveweight, kg		
Initial	219	219
Final	313	319
Feed intake, kg/d	8.0	7.7
Rumen VFA, molar %		
Acetic	74	69
Propionic	19	26
Butyric	6	3
Fertility (% cycling)	58	92

The effects of by-pass protein on conception rates of cows grazing sub-tropical pasture during the dry season are shown in Table 5.3. A supplement providing fermentable energy (molasses) was much less effective, confirming the report of Moseley *et al.* (1982) that it is the "quality" of the energy (i.e., energy in the form of glucogenic compounds) which is the critical issue.

**Table 5.3. Liveweight and conception rates of beef cows (with first calves at foot) grazing native pasture are improved by feeding by-pass protein (cotton seed meal); a supplement of fermentable energy (molasses) had little effect (Source: Hennessy, 1986).**

	No suppl	Molasses	Cottonseed meal
Liveweight (kg)	302	332	343
Pregnancy (%)	10	20	60

### *Growth of the foetus*

The growth of the conceptus has little effect on the protein and energy demand of ruminants until the last third of gestation when most of the foetal tissues are deposited. Because of the time course of growth of the

conceptus which increases the daily need for nutrient to only a small extent, it appears that rumen function even on diets of low digestibility can support the birth of a viable offspring of normal weight. This was shown in studies in which urea was included in the drinking water of ewes on nitrogen deficient pasture (Table 5.4).

**Table 5.4. Urea supplementation in the drinking water of ewes grazing low-nutritive value pasture reduces ewe weight loss, increases lamb survivability and increases pre-weaning growth rate of the lambs (from: Stephenson *et al.*, 1981).**

	Pasture	Pasture + urea
Ewes lambled	20	20
N intake (g/d)	8	15
Ewe liveweight change (kg)	-12	-8
Lambs surviving	12	16
Lamb birthweight (kg)	2.9	3.2
Lamb growth (g/d)	35	81

Increases in calf birth weight were recorded when pregnant cattle, given a basal diet of hay of low digestibility (45%), were supplemented with urea. However, to prevent bodyweight loss and/or promote weight gain of the dam through pregnancy, it was necessary to provide additional by-pass protein (Table 5.1).

It appears that urea supplementation enhances milk production to a level that ensures survival of the offspring. But to allow the young animal to grow, milk yield must be further stimulated by feeding a by-pass protein meal.

### *Male reproduction*

Male reproduction has been enhanced under grazing conditions by supplementary feeding. Lindsay *et al.* (1982) showed that bulls could be maintained in good condition on poorly digestible, low-nitrogen spear grass pasture by providing 1 kg daily of a protein supplement (Table 5.5).

**Table 5.5. Effect of supplements of by-pass protein (cottonseed meal, meat meal and fish meal) on reproductive parameters of bulls grazing dry pasture (0.4% N in DM) (Source: Lindsay *et al.*, 1982).**

	Control	By-pass protein
Initial weight (kg)	433	433
Liveweight change (kg)-40	+14	
Roughage intake (kg/d)5.55	7.74	
Change in scrotal circumference (mm)	-20	+0.7

More importantly, the circumference of the scrotum decreased considerably when no supplement was fed; and it is known that a bull with a lower scrotal circumference is less fertile and has a lower libido (Blockey, 1980). This shows quite clearly that protein nutrition influences male fertility. As with female fertility there appears to be evidence for beneficial responses to manipulating propionate production in the rumen. At the same feed intake, bulls reached puberty earlier and, at puberty, had a greater scrotal circumference and larger testicles (Neuendorff *et al.*, 1982)

### **Milk production**

The major constraint to milk production on diets based on crop residues and agro-industrial by-products appears to be the availability of glucogenic compounds to provide the glucose for lactose synthesis and for oxidation to provide the NADPH for synthesis of fatty acids (e.g., Figure 5.2).

There is good evidence that, in large ruminants, about 50% of the fatty acids of milk arise from dietary fat. A dietary source of lipid can thus reduce considerably any imbalance caused by relative deficiencies of glucogenic energy and amino acids in the end products of rumen digestion. For many feeding systems in the tropics the level of fat in the diet could be a primary constraint to milk production. This could be particularly important in diets based on molasses or sugar cane. Supplementation of lactating animals, particularly on diets based on tropical pastures, crop residues and sugar-rich agro-industrial by-products, should aim to correct the imbalances of nutrients for milk production. By-pass protein usually increases feed intake and as a consequence promotes milk production. But to balance energy quality,

fat must be mobilized and glucose diverted from oxidation and tissue synthesis to lactose production. In these circumstances, animals tend to lose body weight (Orskov *et al.*, 1977). Dietary fat may reduce this effect. Adding a source of by-pass starch in such a diet balances the ratio of glucogenic precursors to protein and energy and will tend to prevent body fat mobilization. The points to be stressed are that:

- By-pass protein because of its effects on feed intake almost always stimulates milk production and depending on the imbalance in nutrients (fermentation pattern) may cause animals to mobilize body reserves. This may be prevented by the use of high-fat, high-protein meals that supply both protein and long chain fatty acids for digestion post ruminally.
- By-pass starch or manipulation of the rumen to give higher propionate production, because it balances nutrients for milk production, may prevent mobilization of body reserves without large effects on feed intake and therefore on milk production. But because it balances the nutrients for milk production, efficiency of energy utilization is increased and body weight is often increased.

### **Wool and hair production**

The effect of nutrition on wool production appears to be dependent almost entirely on the quantity, and quality, of the balance of amino acids absorbed. Therefore, feed intake is the primary limitation to wool or fibre growth although at any one feed intake, wool growth can be stimulated by altering the balance of protein relative to energy in the products of fermentative digestion (e.g., removing protozoa from the rumen). Thus on diets that require fermentative digestion, including those based on sugars or fibre, a by-pass protein supplement will increase wool growth (Table 5.6).

## **GUIDELINES FOR DEVELOPING FEEDING STRATEGIES FOR RUMINANTS**

### **Introduction**

When fibre-rich crop residues and by-products are the primary feed resource for ruminants, feeding strategies must be based on a clear understanding of the relative roles and nutritional needs of rumen micro-organisms and of the host animal (see above).

**Table 5.6. Goats (G) and sheep (S) fed highly fermentable feeds need by-pass nutrients in order to produce wool; diet was 3% oat hay, 25% maize flour, 15% molasses, 15% sucrose, 12.5% barley grain, 4.5% urea, 0.5% minerals/vitamins; by-pass supplements were formaldehyde protected casein alone or plus cracked rice (Source: Throckmorton and Leng, 1984).**

	Basal		By-pass protein		By-pass protein + By-pass starch	
	G	S	G	S	G	S
Daily liveweight gain (g)	32	45	68	107	81	119
Patch weight at 105 days (mg/cm <sup>2</sup> /d)	0.54	0.74	0.82	1.27	0.76	1.11
Feed intake (g/d)	465	538	604	755	664	736
Feed conversion (DM)	14.8	11.9	8.9	7.0	8.2	6.2
Rumen fluid half life (hr) 16.1	14.1	8.6	9.0	12.1	12.7	

\* Wool or hair clipped from a 10 cm<sup>2</sup> mid-side patch

The new approach identifies high fibre forages as the most important category of tropical feeds and emphasizes that these are imbalanced sources of nutrients for both rumen micro-organisms and the animal. The recent advances in understanding of rumen function and the role of "by-pass" or "escape" nutrients has revealed important ways forward for improving productivity of ruminants in the tropics. These concepts have been tested and applied on a wide scale in many tropical countries and can be summarized as follows:

The research which led to the new concepts of "balancing nutrients" has shown that provided the protein to energy ratio in absorbed nutrients is high, productive efficiency can be up to tenfold that predicted from traditional feed evaluation methods (Leng, 1990). The breakthrough came when the ruminant animal was treated as a two compartment system (Figure 5.6) (Leng and Preston, 1976; Preston and Leng, 1987) in which there is:

- A microbial fermentative digestion system that functions efficiently when there is a balanced supply of microbial nutrients within an appropriate ecosystem.

and where:

- The animal relies on the products of the microbial system and those digestible feed components that escape the rumen fermentation.

**Figure 5.6. Nutritional strategy for feeding the ruminant (Source: Preston and Leng, 1987)**

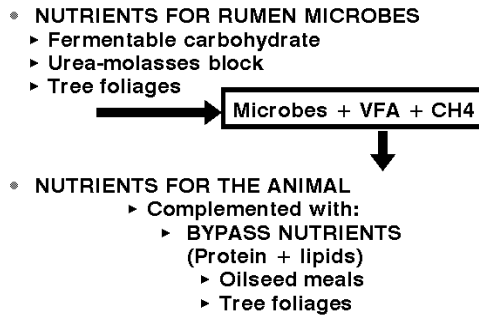

The results of applying these concepts have substantiated the hypothesis that ruminants in the tropics fed on fibrous crop residues and dry pastures were not deficient in energy *per se* but were inefficiently utilizing the feed that was available. Therefore, when nutrients were more closely balanced there were substantial gains in productivity.

The rumen microbial system alters the nutrients finally made available to the animal converting fibrous carbohydrate, sugars and starches and soluble protein to microbial cells, short chain organic acids and waste products in the form of methane, carbon dioxide and heat. The critical issue for the animal is the ratio of protein (from microbial and dietary origin) to energy yielding substrates (the P/E ratio expressed as g protein/ MJ of energy from volatile fatty acids available for metabolism), since this determines efficiency and level of productivity (Preston and Leng, 1987). However, even when the rumen system is optimized by providing an array of essential nutrients for microbes, the P/E ratio is usually still inadequate to support optimum efficiency of utilization of the basal feed resource.

The demonstration in Cuba (Preston *et al.*, 1967) that flame-dried fish meal (a protein known to escape the rumen fermentation) dramatically increased rate and efficiency of liveweight gain on highly digestible but low protein diets (molasses and urea), led to the broader



understanding of the critical role of: (i) supplying nutrients to the rumen microbial eco-system, and (ii) of protein supplements to the animal, as factors determining rate and efficiency of ruminant production from forage-based diets. This in turn led to the introduction of the concept of "by-pass protein" (Leng *et al.*, 1977).

Another important step in the understanding of tropical ruminant nutrition has been to appreciate that, when animals are in an environment where the temperature is less than their body temperature, they will oxidize acetogenic substrate to maintain body temperature. This results in an increase in the effective P/E ratio in the metabolites available for production. Conversely, when environmental temperatures exceed body temperature the resultant heat stress causes a rise in basal metabolic rate and the catabolism of protein. In practice, this means that the requirement for protein (amino acids) per unit energy substrate will generally be greater for ruminants in tropical environments than for those in temperate environments. In summary the major features of the new approach are:

- In the tropics there is a greater response by ruminants to supplementation strategies as compared with responses in temperate countries.
- Feed evaluation standards developed in temperate countries have little application in the tropics and have been positively detrimental to development of sustainable livestock production systems in those regions.

The proposed strategy considers the ruminant animal as composed of two subsystems:

- The rumen
- The animal

### **Feeding the rumen microbes**

- The first need is for ammonia (>200 mg/litre of rumen fluid to maximize intake as well as digestibility) (Figure 5.7), most conveniently ensured by free access to multinutritional blocks based on urea-molasses.

- Macro and micro-minerals (P, S and Co are most important but will be supplied usually by other dietary components (e.g., in multi-nutritional block, in green forage and/or by-pass protein supplement)
- Other micro-nutrients (amino acids, peptides, branched chain acids) will rarely be deficient as these arise from lysis of microbes and are supplied by other dietary components as in the case of minerals).
- An optimum ecosystem to promote rapid colonization of basic substrate. A small quantity of highly digestible green forage (about 2 kg fresh matter/100 kg liveweight is usually sufficient) is the best way of safeguarding this parameter (Figure 5.8).
- Maximum rate of intake of fermentable carbohydrate. Usually the most appropriate way will be by ensuring free choice selection of the basal feed which in the case of a fibrous crop residue means, wherever possible, offering more than 50% in excess of needs (Owen 1994; Figure 5.9). In general, the less digestible the basal feed, the higher degree of offer is required (e.g., at least twice the expected intake in the case of residual pressed sugar cane stalk (Figure 5.9)). The other approach is to treat with ammonia (by urea-hydrolysis) (see Chapter 7).

**Figure 5.7. The optimum rumen ammonia concentration to optimize both fibre digestibility and intake is about 200 mg/litre (Source: Perdok, 1987).**

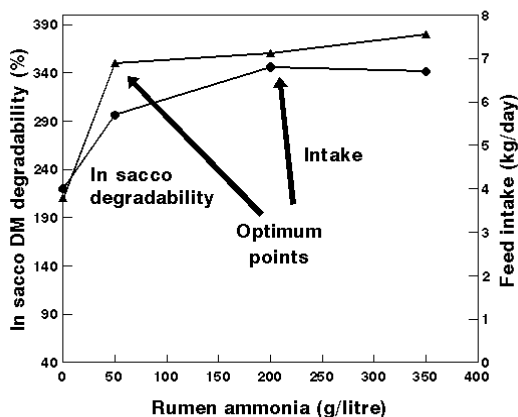

**Figure 5.8.** Adding a small amount of *Leucaena* hay to a maize stover diet increases rate of maize stover digestion in cattle (Source: Kabatange and Shayo, 1991).

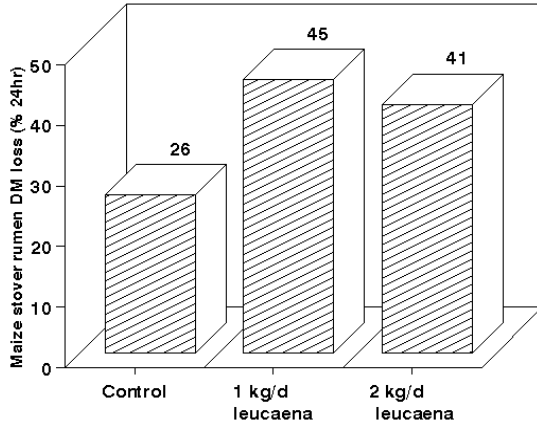

**Figure 5.9.** Effect of level of offer on intake of residual pressed cane stalk (Owen, 1994).

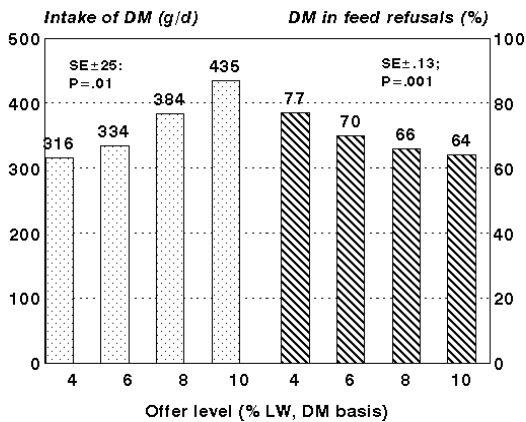

### Feeding the animal

The aim is to increase the protein/energy (P/E) in the nutrients absorbed for metabolism by:

- Increasing the efficiency of rumen function .
- Supplying by-pass protein.

The amounts of supplement to be provided will be dictated by the marginal value of animal product added per unit of additional supplement. This in turn will be determined by the shape of the response curve between output and input. Examples of such relationships are given for sugar cane in Mexico (Figure 5.10) and wheat straw in China (Figure 5.11).

Supplying foliages with natural protection as a function of the protein (many tropical tree foliages contain phenolic and other substances that react with the protein during chewing, thus protecting it from rumen fermentation) usually will be the most economical way.

Results are given in Figure 5.12 for the effects on milk production in goats of supplementing a basal diet of King grass with the foliage of *Erythrina poeppigiana*. Milk yield was a direct function of the amount of legume foliage added.

**Figure 5.10. Fattening cattle with sugar cane; the effect of by-pass nutrients present in rice polishings (Source: Preston *et al.*, 1976).**

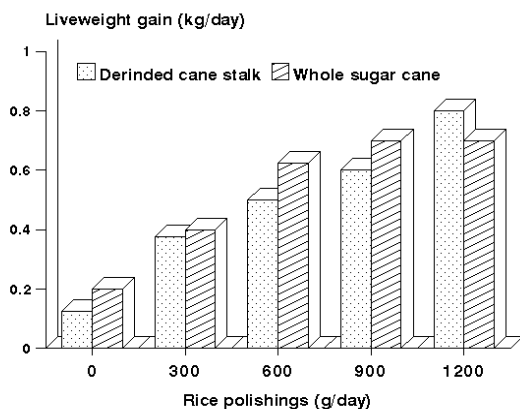

Figure 5.11. Response curve to cottonseed cake of steers fattened on a basal diet of ammoniated wheat straw at two locations in China (Source: Dolberg *et al.*, 1994).

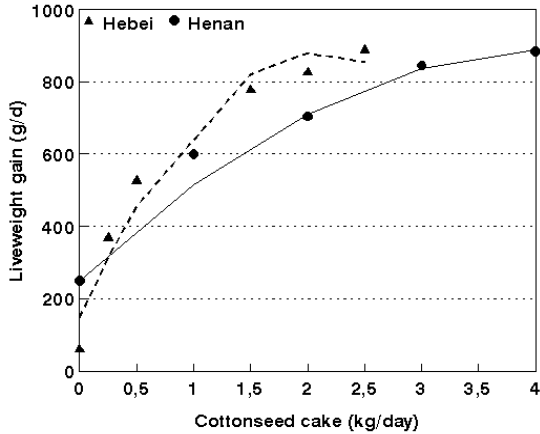
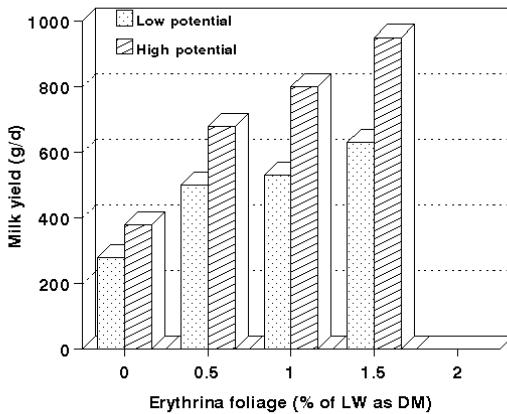
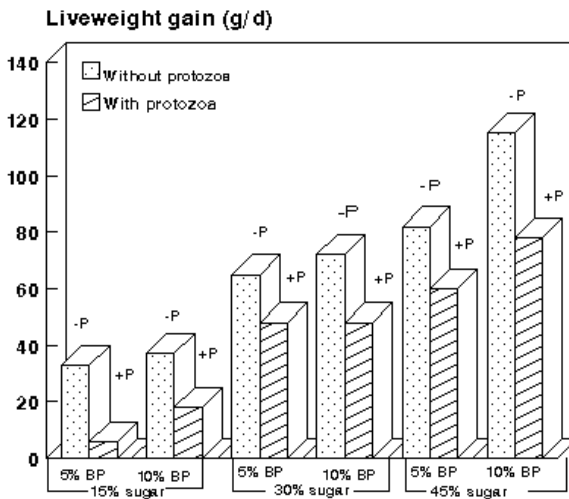

Figure 5.12. Milk production of goats fed King grass: effect of giving *Erythrina* tree foliage (Source: Esnaola and Ríos, 1990).



Controlling (reducing the numbers and/or activity of) the rumen protozoa will increase the flow of protein to the small intestine, and thus increase the P/E ratio and hence the productive parameters (Preston and Leng, 1987). This has been conclusively demonstrated in experiments where protozoal populations have been eliminated by detergents (e.g., see Figure 5.13).

**Figure 5.13. Effect of defaunation on growth of lambs fed straw, sugar, urea and cottonseed meal (BP protein) (Source: Navas and Leng, 1991).**



Many tropical tree and shrub foliages contain secondary plant compounds that naturally inhibit protozoal activity. However, although reductions in rumen protozoal numbers have been obtained by supplementing the animal with foliages from trees such as *Enterolobium cyclocarpum* (Kang *et al.*, 1994) or with seeds rich in saponins from the tree *Sapindus saponaria* (Diaz *et al.*, 1993), it has not yet proved feasible to translate these effects into practical production systems.

For some production traits (e.g., growth and milk production) it will be advantageous to supply by-pass oil since this can be incorporated directly into milk and body fat, and is less costly (biochemically) than

synthesizing fat from acetate and glucose. On high-fibre diets, such as crop residues and pasture, "un-protected" lipid added above 5% of the diet dry matter will depress fibre digestion. This negative effect can be avoided by "protecting" the lipids with calcium salts to form insoluble soaps (Palmquist and Jenkins, 1982; Palmquist, 1984).

There may be other indirect benefits from use of oil. Thus, Rodriguez *et al.* (Rodriguez, L. and Cuellar, P., 1994, unpublished data) mixed 6% crude palm oil and 2% calcium hydroxide with the leaves of the legume tree *Erythrina fusca* and found that the intake of leaves was increased. Supplementing crossbred (F<sub>1</sub> Holstein x Zebu) cows (basal diet was grazing on African Star grass pasture) with 6 kg/day of this mixture (6% oil, 2% calcium hydroxide and 92% leaves) supported the same milk production as 4 kg daily of concentrates.

## Chapter 6

## Feed resources for ruminants

*Treatment with urea, feeding of multi-nutritional blocks and high-offer level feeding are the interventions most likely to increase the potential nutritive value of fibrous crop residues. The exploitation of this potential will be determined by the level of supplementation with "by-pass" nutrients, especially protein. The optimum level of supplementation will depend on the cost of the supplement and the added value of the increase in production.*

*Multi-purpose crops which provide both feed and fuel will increasingly find a role as the demand increases for renewable sources of energy and increasing emphasis is put on the need for farming systems that have positive effects on the environment, especially the content of organic matter in soils.*

### **LIVESTOCK SYSTEMS BASED ON CROP RESIDUES**

This system will have its application in regions of very high population density where crop production is the predominant activity and the major feed resources are the residues and by-products of food crops.

### **STRAWS FROM CEREAL CROPS**

#### **Balance of nutrients**

Crop residues and fibrous agro-industrial by-products are characterized by low to moderate digestibility, and low levels of nitrogen, protein and minerals. Classical temperate country wisdom diagnosed energy density as the first constraint and the proposed solutions were supplementation with energy-rich feeds (e.g., cereal grains, root crops or specialist forage crops for feeding directly or after ensiling). Even when it was recognized that these strategies were inappropriate and uneconomic, the classic approach persisted and scientists sought solutions through chemical treatment of the fibrous feeds to improve digestibility.



There is a definite place for chemical treatment of fibrous crop residues but the first step must be to correct the balance of nutrients, since this is the first constraint to productivity of livestock fed these resources. The system involves:

- Feeding the rumen microbes
- Feeding the animal a source of by-pass protein

### **Feeding the rumen microbes**

There are three approaches to providing the rumen microbes with a better array of nutrients, including fermentable energy (Figure 6.1):

- Supply critical nutrients (missing in the residue) by means of a multi-nutritional block (Leng, 1990).
- Facilitate selection by the animal of the more digestible components of the residue by offering at least twice the amount it can be expected to consume (Owen, 1994).
- Saponify partially the phenolic linkages with acids or alkalis.

The choice of method will be determined by the relative availability of the residue, alternative end uses (e.g., as fuel or as roofing material), the cost of the urea (or ammonia) and the convenience of the technology.

**Figure 6.1. Strategies for making better use of fibrous crop residues.**

### **THE ALTERNATIVES**

#### **■ SELF SELECTION**

- Offer **TWICE** the expected intake
- Free access to multinutritional block

#### **■ AMMONIFICATION WITH UREA**

- 5% urea in straw DM
- 30–50% water

-----  
 In both cases feed:

- 0.5 kg/d rice polishings (or cottonseed cake)
- 2–3 kg/d green feed (or 3 hr/d grazing)  
 (preferably legume tree foliage)

Provision of multi-nutrient blocks has had the widest impact (Sansoucy, 1995). The selection approach has advantages when there is a need for feed and fuel, since the parts of the residue rejected by the animal are those which are drier and more lignified and therefore of higher fuel value (Owen, 1994).

Saponification with ammonia accomplishes two tasks. It supplies ammonia and also energy (by breaking phenolic linkages in the cell wall) to the microbes.

### Multi-nutrient blocks

Fibrous crop residues and agro-industrial by-products are the typical diet of ruminant animals in most tropical countries and often are the only feed resource in extended dry seasons. These feeds are characterized by an imbalanced array of nutrients, of which fermentable nitrogen is usually the first limiting; organic matter digestibility is also usually below 50%. The use of solidified blocks containing urea, minerals (and often rumen by-pass nutrients), pioneered by Professor R.A. Leng of the University of New England, Armidale, Australia, to supplement these fibrous feed resources has been outstandingly successful in a large number of countries. The FAO Feed Resources Group, with the help of the FAO Technical Cooperation Programme, has initiated projects in more than 60 countries using this technology (Sansoucy, 1986).

**Table 6.1. Formula for multi-nutrient blocks containing sugar cane scums (or juice) and with addition of clay to improve gelling characteristics (Source: SIDA-MSc, 1994).**

Ingredient	% Fresh weight	% Dry weight
Scums*	46	16
Clay (dry)	9	14
Urea	4.5	7
Cement	4.5	7
Salt	2.3	3.5
Maize bran	15	23
Sunflowerseed hulls	18	28

\* Juice and flocculated protein and minerals

Typical results from providing multi-nutrient blocks are given in Figure 6.2, taken from a series of villages in India as part of the NDDB (1982) programme. The major problem with the technology has been the

difficulties in some situations of making blocks of sufficiently hard consistency to limit intake and ensure there will be no risk of urea toxicity which might occur if intake of the block is excessively high. Molasses, which is the usual basis of the multinutritional block, is also not always available or it may be too expensive through high transport charges.

### **High-offer feeding**

Typical results using the high-offer feeding system to facilitate selection are in Figure 6.3. The data show that lambs almost doubled their rate of growth when the offer level of sorghum stover was increased by a factor of between 2 and 3. This method is especially appropriate for the residual pressed sugar cane stalk (after partial juice extraction) (Figure 5.9).

### **Ammoniation**

Alkali treatment of fibrous crop residues is well researched (Sundstøl and Owen, 1984) and the possibility of using urea as a source of ammonia (Dolberg *et al.*, 1981) led to expectations of rapid implementation in many developing countries which, however, have not been realized (Owen and Jayasuriya, 1989) for several reasons (Dolberg, 1992). Too much attention to treatment technique *per se*, and too little to supplementation strategies aimed at employing biologically effective supplements available to the farmers, are some of the explanations. Unsupplemented ammoniated straw supports production levels far below the level potentially made available by the increase in digestibility and intake due to ammoniation (Preston and Leng, 1987). Low levels of production may not earn farmers sufficient income to pay for the ammoniation treatment and, consequently, they lose interest and the technology is not taken up.

**Figure 6.2.** Introduction of multi-nutritional blocks in Indian villages led to significant increases in milk production (Source: Kunju, 1986).

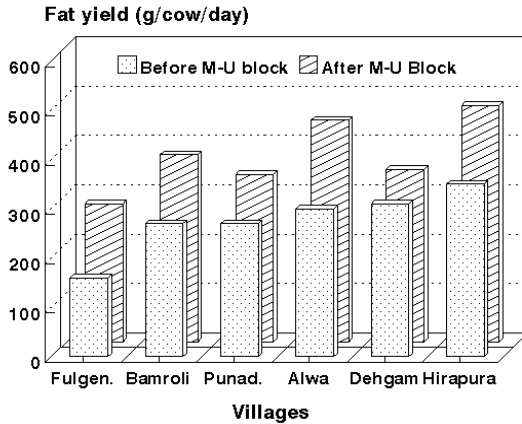

**Figure 6.3.** Given the opportunity to select, sheep will consume the most nutritious parts of a feed (sorghum stover in this trial) and respond with almost a doubling of performance (Aboud *et al.*, 1990).

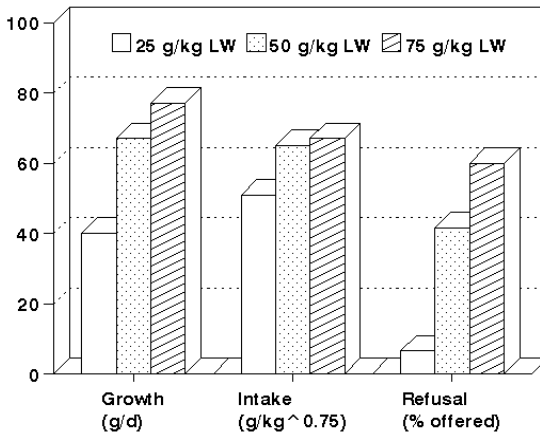

Lack of feedback from extension or no communication at all between research and extension can be mentioned as some of the other reasons for lack of impact of new technologies. There has been insufficient research with a farmer's perspective in the area of crop residue utilization although good extension work must be based on precise knowledge.

A large-scale FAO/UNDP-supported project in China has demonstrated that, provided "by-pass" protein supplements are available and used (in this case cottonseed cake), then the economic and political impact can be huge (Finlayson *et al.*, 1994). Typical data for cattle fed with ammoniated (urea treatment) wheat straw in this project were given previously in Figure 5.12.

It is generally believed that the response to ammoniation has two components: an increase in digestibility due to partial saponification of the lignin-cellulose-hemicellulose linkages, and a greater feed intake arising from the greater supply of ammonia to the rumen micro-organisms.

Ammonification supplies the nitrogen needs of rumen microbes as well as increasing digestibility; however, it is an expensive way of supplying the nitrogen, as the level required for effective treatment of the residue is some 50% greater than what is needed by the rumen microbes. An important economic issue, which has not been adequately evaluated, is the relative effectiveness of ammoniation using urea as compared with supplementing untreated straw with a molasses-urea block.

The data in Table 6.2 show that ammoniation gave slightly superior results. However, the straw on both treatments was fed at normal levels (i.e., some 15% above intake). This work must be repeated but with high-offer level feeding of the straw complemented with the blocks.

Another issue that requires clarification is the optimum level of urea for effective ammoniation. The usually recommended level is 5% of the dry weight of the residue; yet researchers in Vietnam contend that a lower urea level of 2.5% urea complemented with 0.5% of calcium hydroxide gives almost as good a biological response and is more economical (Bui van Chinh, unpublished observations). As the price of urea is tending to rise, as Governments in developing countries reduce agricultural subsidies, it is opportune to examine more closely the possibility of using lower inputs.

The ammoniation process is described in Chapter 7.

**Table 6.2. Effect of ammoniation of rice straw or supplementation with molasses-urea block (MUB) on performance of growing heifers during consecutive periods in summer (150 days) and winter (90 days) in Hanoi province (Source: Bui van Chinh *et al.*, 1994).**

	Ammoniated straw	Untreated straw + MUB
Initial wt (kg)		
Summer	156	156
Winter	224	210
Mean	190	183
Final wt (kg)		
Summer	224	210
Winter	264	243
Mean	244	227
LWt gain (kg/d)		
Summer	0.453	0.360
Winter	0.444	0.367
Mean	0.449	0.363
Intake straw DM (%LWt)		
Summer	1.62	1.1
Winter	1.7	1.17
Mean	1.66	1.17
Total DM (%LWt)		
Summer	2.63	2.34
Winter	2.27	2.14
Mean	2.47	2.22
Feed DM conversion		
Summer	11.3	11.9
Winter	12.7	13.3
Mean	11.8	12.7

### Strategic supplementation

As with untreated crop residues, appropriate supplementation is the key to securing adequate animal response (see Figure 5.12). Mostly protein-rich by-products from oilseed or cereal grain milling have been used as the source of "by-pass" protein (Preston and Leng, 1984). However, there is much potential in the use of leaves from legume trees for this purpose (Figure 6.4).

The experience in India by the National Dairy Development Board in their rural development programme "Operation Flood" affords an example of the impact of replacing inappropriate "temperate country technologies" (supplementing crop residues with "balanced dairy concentrates") with appropriate technologies (multi-nutrient blocks and "by-pass" protein) based on the concepts of strategic supplementation of rumen microbes and the animal (Leng, 1984).

**Stovers from maize and sorghum**

There are few reports of uptake by farmers of the ammoniation technique applied to stovers derived from maize, sorghum and millet, although technically it has been shown to be feasible but more difficult than for straws, due to the bulkiness of the material (Jayasuriya, N., personal communication). The component parts of these residues can differ quite widely in digestibility and it would seem more appropriate perhaps to use the "high-offer" feeding system to facilitate selection of the more digestible components rather than urea treatment.

Correct supplementation of the untreated maize stover can lead to a doubling of live weight gain as demonstrated in Figure 6.5. The effects can be explained almost entirely by improvements in rumen function brought about by supplementation with urea and small amounts of grass (see Chapter 5).

**Residues from plantains and bananas**

In some tropical regions, plantains and bananas are the staple of the human diet (e.g., in the Kiliminjaro region of Tanzania). The principles for using these as the basis of the diet of ruminant animals are the same as for cereal stovers. The bulk of the biomass residue is in the pseudo-stem which is of low nitrogen content but highly digestible, while the protein in the leaf lamina appears to be largely bound to tannin-like substances giving it a low digestibility (Kimambo and Muya, 1991). Therefore the supplements needed are:

- Multi-nutritional blocks to provide urea and minerals;
- A source of by-pass protein (from oilseed meals, rice polishings or as leaves from legume trees).

**Figure 6.4.** Leaves from the leguminous tree *Leucaena leucocephala* (2 kg/d) were as effective as rice polishings (500 g/d) in stimulating growth of cattle fed ammoniated rice straw (Source: CIPAV, 1987).

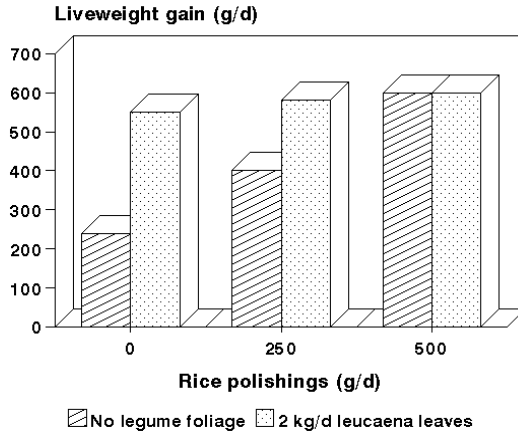

**Figure 6.5.** Supplements of urea and grass markedly increase growth rates of cattle fed untreated maize stover and cottonseed cake (Source: Ocen, 1992).

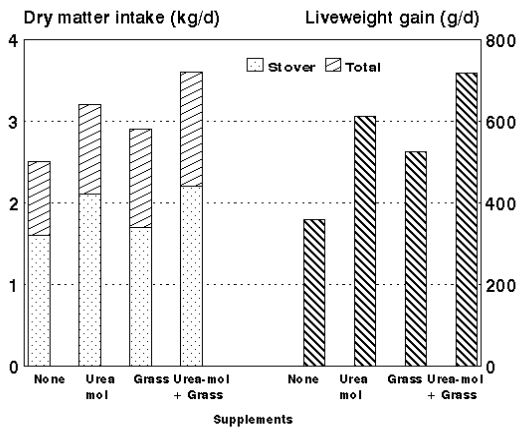

\* All treatments had 1 kg/d of cottonseed cake



## FIBROUS RESIDUES FROM INDUSTRIAL AND ARTISAN CANE SUGAR MANUFACTURE

### Sugar factory bagasse

The residual fibre after industrial separation of sugar by repeated extraction (see Figure 7.1) is described as "factory" bagasse to distinguish it from that produced in simple 2- or 3-roll crushers (*trapiches*) which also contains residual juice (from 20 to 30% of the dry matter). Factory bagasse contains about 45% cellulose, 35% hemicellulose and 10% lignin. The raw material has a very low digestibility (about 30%). However, dramatic improvements can be brought about by high pressure steam (13 kg/cm<sup>2</sup>; 200°C) which, through acid hydrolysis (acetic acid is generated in the process), solubilizes the hemicellulose component (Wong *et al.*, 1974; Figure 6.6).

**Figure 6.6. High pressure steam is an effective way of increasing the digestibility of sugar cane bagasse (Source: Basile and Machado, 1990).**

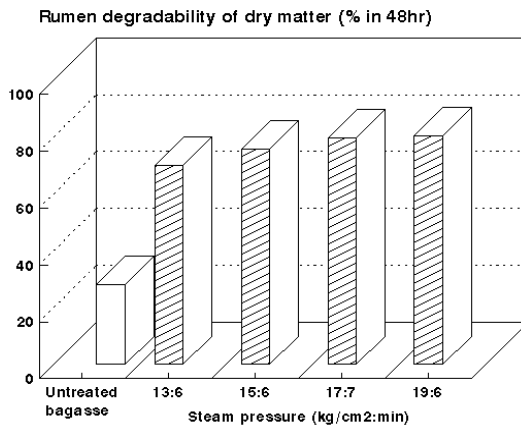

Steam hydrolyzed bagasse must be supplemented with rumen and by-pass nutrients (Naidoo *et al.*, 1977; Machado, 1989) after which it supports quite high levels of production in fattening cattle (Osorio *et al.*, 1990; Basile and Machado, 1990). This technology has been applied commercially in intensive cattle fattening in Colombia (CIPAV, 1987)

and Brazil (Machado, 1989). The Colombian programme has been discontinued in favour of processing the bagasse for paper. However, in Brazil where the integration of sugar and alcohol production results in large surpluses of bagasse it is reported that more than 200,000 cattle are being fed with steam-hydrolyzed bagasse (Machado, P., personal communication). The technology has also been introduced into India (Rangnekar, personal communication).

Alkaline hydrolysis of factory bagasse with sodium hydroxide is also an effective method of upgrading the bagasse and has been employed in Cuba on a large scale (Martin, 1987), although mostly with the short fibre fraction (*bagacillo*) which remains when the larger fibres are separated out as raw material for paper production. The method is relatively costly, as well as polluting because of the large quantities of sodium hydroxide required. It is not a sustainable technology and therefore is not recommended.

Rising oil prices and increasing awareness of environmental issues will almost certainly favour the future use of bagasse as fuel with electricity generation as the major output, in co-generation schemes (Ogden *et al.*, 1990) which will also produce sugar, alcohol and/or molasses from the cane juice (Preston and Echaveria, 1991).

### **Sugar cane tops and pressed sugar cane stalk ("trapiche" bagasse)**

The fibrous residues derived from farm scale fractionation of sugar cane (Chapter 7), and from artisan production of "*panela*" or "*gur*", which have potential for feeding to herbivores are:

- The cane tops
- The pressed stalk

#### *Cane tops*

When complemented with rumen and "by-pass" supplements, cane tops will support liveweight gains of the order of 700 g/d (Ferreiro *et al.*, 1977) in fattening cattle and 3,000 litres lactation yield in milking animals (Boodoo *et al.*, 1990a). It is important to encourage selection by offering quantities of tops which exceed by at least 50% the expected intake. Under these circumstances the animal has been observed to preferentially select the growing point of the cane and to reject in large part the leaf blade (Boodoo *et al.*, 1990b).

The justification for this selection can be seen in the data for dry matter degradabilities in rumen nylon bags (Figure 6.7). The growing point has a much higher rate of degradability than the leaf blade, and is comparable to that of nutritious grass.

**Figure 6.7. Digestibility is higher for the growing point of the sugar cane tops than for the leaves (Source: Boodoo *et al.*, 1990b).**

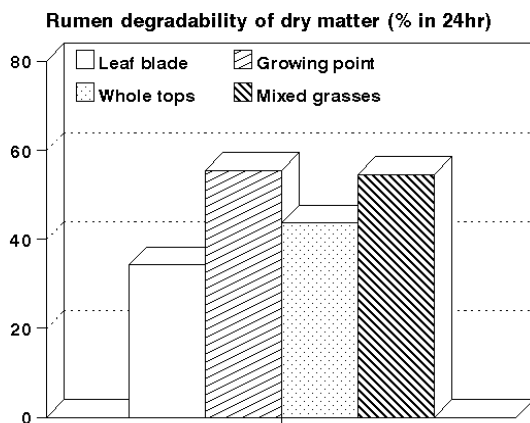

The African hair sheep appears to be a particularly appropriate target animal for utilizing the cane tops. Since late 1989, some 100 breeding ewes and their progeny have been managed in full confinement on this system in Colombia. They have free access to cane tops, multinutritional blocks and a 9:1 mixture of poultry litter and rice polishings. The advantages of sheep in such a system are:

- Low investment in animals and housing (renewable bamboo poles and palm leaves). No concrete is needed as the rejected fibrous components of the feed are used as built-up litter.
- The sheep are highly resistant to common diseases and the housing system reduces risks of endo- and ecto-parasite infections.
- Sheep are selective feeders and adapt more readily to confinement than goats.

- Sheep production is especially suitable for cash-poor smallholder farmers since:
  - Investment risk is distributed among many animals rather than in few, as would be the case for cattle.
  - A lamb can be consumed by a family in 1 or 2 days, avoiding need for refrigerated storage, or it (or a sheep) can be sold for cash. None of this is possible with cattle.

### *Pressed sugar cane stalk*

The pressed stalk which remains after a single-pass extraction of the cane stalk through a 3-roll mill (or 2 to 3 passes in a mill with only 2 rolls) contains some 20-30% of soluble sugars in the dry matter. The associated cell wall material is, however, of low digestibility as it has the same composition as sugar factory bagasse which is only about 28% digestible (Wong *et al.*, 1974).

The pressed stalk is particularly appropriate for manipulating via the high-offer level feeding system (Figure 5.9). When it is coarsely chopped and offered at 2 to 3 times expected intake, it is relatively easy for cattle and sheep to select the more digestible component (the soft pith, rich in sugar) (Vargas *et al.*, 1994). This feed should be supplemented with multi-nutritional blocks, fodder tree foliages (about 2-3 kg fresh material per 100 kg liveweight) and restricted amounts (500 g/day) of a supplement rich in by-pass protein such as rice polishings. Growth rates of F1 crossbred (Holstein x Zebu) from weaning to point of calving on this feeding system have been of the order of 500 g/day (Rodriguez, L. and Cuellar, P., 1994, Unpublished data). Fattening bulls have gained at similar rates when supplemented with *Gliricidia sepium* foliage, a 20% urea block and 1 kg/day of a mixture of poultry litter and rice polishings (Molina, C., 1994, personal communication).

## **LIVESTOCK SYSTEMS BASED ON CROPS WITH HIGH YIELDS OF BIOMASS**

### **The concept of tropical biomass and integrated farming systems as the basis of sustainability**

The essential features of a strategy to optimize production and use of natural resources is to ensure that the biomass can be processed in a way that will contribute efficiently to provision of human food, animal feed,

chemicals and energy. The animal feed element must be further defined so as to take account of the differing needs of monogastric and herbivorous animals.

The corollary to fractionation is integration, since in order to efficiently utilize the different components of plant biomass (e.g., soluble cell contents, cell wall material with different degrees of lignification), it is essential to tailor end uses accordingly. Thus it makes no sense to feed sugar cane juice or bananas to herbivorous animals when much higher biological efficiencies can be obtained by using them as the basal diet of pigs and poultry. Similarly, it will be more economical and ecologically advantageous to convert sugar cane bagasse, tree branches and highly lignified crop residues into fuel than to process them for feeding to herbivorous livestock. Wherever possible the farming system therefore should offer opportunities for both monogastric and herbivorous livestock production, and for generation of energy.

Thus, although it is feasible to feed a wide range of tropical high-biomass crops, including whole sugar cane, to ruminant livestock, such measures should be viewed as short term solutions. The correct long term approach must be to fractionate the crop according to the most profitable end-product possibilities and to manage and use them always with the aim of optimizing the productivity of the whole farming system.

## **SYSTEMS BASED ON SUGAR CANE AND ITS DERIVATIVES**

### **Strategy for use of sugar cane as animal feed**

An important advantage of sugar cane as a multi-purpose crop is its beneficial effects on soil fertility (Figures 6.8 and 6.9). Thus in the acid-sulphate soils region in the Mekong Delta in Vietnam sugar cane is grown in short rotation with rice (8 months cane: 3 months rice) precisely because the rice crop (for food security) would have very low yields if it were not preceded by the sugar cane. In addition, the farmers inter-cropped the cane during the first 3 months with legume beans; the reason was that, in association with cane, there was negligible pest damage on the beans, compared with growing the beans as a single crop.

Figure 6.8. Effect on soil fertility parameters of removing or returning sugar cane leaf trash to the soil (Source: Phan Gia Tan, 1994).

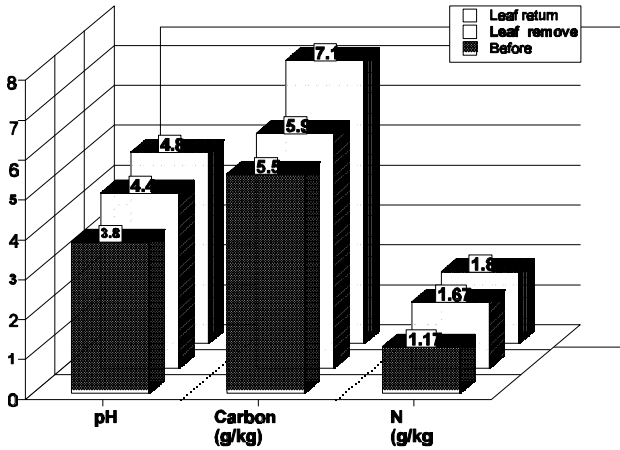
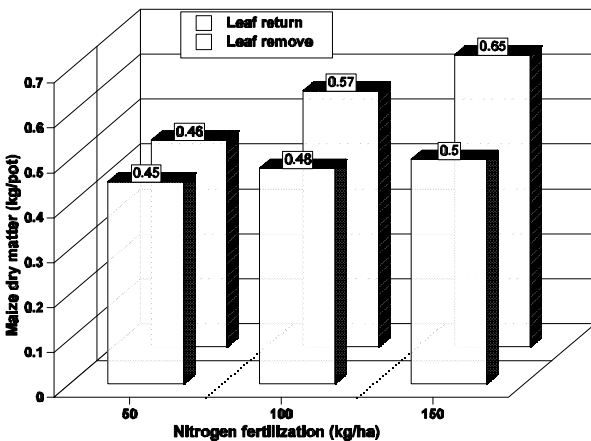

Figure 6.9. Effect on soil fertility (measured as growth of maize plants in soil samples taken from experimental plots) of removal or return of sugar cane leaf trash (Source: Phan Gia Tan, 1994).



Maintenance and, even better, the capacity to increase soil fertility will become increasingly important in the choice of crop rotations. Thus, sugar cane has potentially many advantages as a component of cropping systems in the tropics. Management systems should be aimed to exploit these potential assets.

In this context the following criteria can serve as a guide in managing cropping systems based on sugar cane:

- Selection of varieties which optimize yield of biomass, pest resistance and ease of fractionation, and not necessarily percentage of sucrose.
- Intercropping with legume grain crops to provide supplementary protein (e.g., soybean and peanuts), to increase biodiversity and improve soil fertility.
- Alley cropping with different species of multi-purpose trees (e.g., 20- 30m strips of trees alternating with the cane) to provide additional protein-rich feed, fuel and timber, erosion control and biodiversity.
- Fractionation (see Figure 7.4) as the preferred processing method to optimize use of the different components.
- Use of the tops and the pressed cane stalk as feed for ruminants.
- The juice for pigs and water fowl.
- The pressed cane stalk for fuel (with or without selection by ruminant animals).
- The leaf trash as an energy source for soil micro-organisms.

### **Chopped whole and derinded sugar cane for ruminants**

The idea of separating the cane stalk into rind and sugar-rich pith, using sophisticated wood processing technology, was promoted strongly by Canadian developers (Tilby, E. and Miller, R., cited by Lipinsky and Kresovich, 1982) in the late '60s and early '70s. The aim was to transform the rind into paper and compressed board and use the residual pith as animal feed. Although theoretically superior to chopped whole cane (DM digestibility of 70 compared with 62%; Montpellier and Preston, 1977), in practice the advantages of the derinded cane over chopped whole cane were insignificant biologically (Figure 5.10) and were more than outweighed by the high investment and operating costs of the derinding equipment.

Research on chopped whole cane as ruminant feed emphasized the

important role of urea (Alvarez and Preston, 1976), of by-pass protein, starch and oil (Ferreiro *et al.*, 1977; Preston *et al.*, 1976; Elliott *et al.*, 1978) and of using sugar cane with high content of sugars (Alvarez and Preston, 1976). Rice polishings - which are relatively rich in well balanced amino acids, starch and oil - have a physical form which facilitates almost complete escape from the rumen (Elliott *et al.*, 1978). They have proved to be the most effective supplement when sugar cane and its derivatives are fed to ruminants (CIPAV, 1987). They are widely available in most tropical countries.

The unique characteristics of sugar cane enabling it to reach its maximum nutritive value in the dry season (Alvarez and Preston, 1976), has made it an attractive complement to pastures which are low in both quantity and nutritive value in the dry season. Restricted feeding of foliage from leguminous trees (*Leucaena* and *Gliricidia*) has proved to be a cost-effective partial replacement of the rice polishings in these systems (Alvarez and Preston, 1976; Molina, C., 1994, personal communication).

However, as has proved to be the case with final "C" molasses, so with whole sugar cane, low profitability of beef and milk production has led to new developments in its use which in the long term promise to bring greater cost benefits. In most situations today, fractionation of the cane stalk into juice and residual pressed stalk for use in integrated farming systems, is proving to be a more attractive strategy with which to face the challenge of making more efficient and sustainable use of tropical biomass resources.

### **Final molasses**

Methods for using high levels of "C" or final molasses as the basis of intensive cattle fattening were developed in Cuba in the late '60s (Preston *et al.*, 1967; Preston and Willis, 1974). These first approaches used fish meal as the source of by-pass or escape protein (Figure 4.2). This was the first large scale commercial application of the concept of by-pass protein feeding, hypothesised originally in 1963 (see Whitelaw and Preston, 1963).

Subsequent work focused on use of cheaper alternatives and led to the idea of supplying both roughage and by-pass protein in the form of crop and tree foliage (e.g., Figure 6.10 and Preston and Leng, 1987).



**Figure 6.10. Fattening steers on molasses-urea; *Leucaena* vs. sugar cane tops as forage source (Source: Meyreles *et al.*, 1982).**

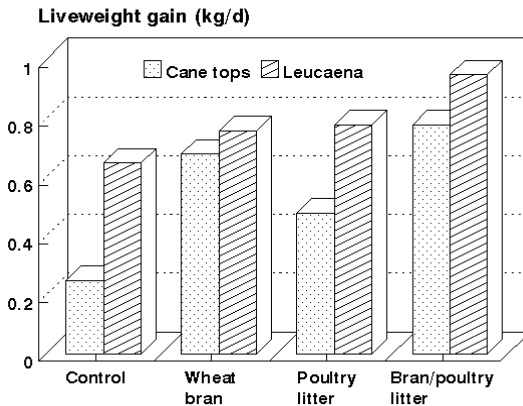

Increased costs of molasses and decreasing profit margins for intensive beef fattening in developing countries have, in most situations, made high level use of molasses uneconomical. Emphasis is now on using molasses as a vehicle for urea and minerals in the form of liquid mixtures (CIPAV, 1987) or as solidified blocks (Leng and Preston, 1984). The latter technology has proved to be particularly attractive and, following its successful introduction in India (Figure 6.2; Kunju, 1986), it has been transferred successfully to many tropical countries (Leng and Preston, 1984; Sansoucy, 1995).

## LIVESTOCK PRODUCTION AND PASTURE

### The grazing animal and sustainable use of natural resource

The role of pasture in tropical livestock production is highly debatable. As practised in tropical Central and South America by "ranchers", most of whom are absentee landlords, the system fails on almost all of the sustainability indicators proposed in Chapter 1. On the other hand, the supervised grazing of common land, roadside grasses, and bunds between rice and other food crops, especially in Asia, affords the basis of a living to countless "landless" farmers, especially women. In Africa,

transhumant pastoralism was a life style, that has gradually become less sustainable due to the impact of "development". The upset of the traditional system, and the imbalance caused in the natural wild life, is what has led to the present widespread erosion and desertification.

Supervised grazing has succeeded in Asia because it is highly integrated with crop production which is the dominant activity and there is no conflict. It is a threat in Africa (e.g., the Hado project in Tanzania; Chapter 1), partly because it was the dominant activity and has come under threat by crop farmers; in Africa, grazing is a source of conflict. In Latin America, ranching is also a life style - witness the highly successful (though morally questionable) advertisement for a successful brand of cigarettes. More than any other human activity, in that continent, it has been responsible for immense ecological and social damage (Figure 6.11).

**Figure 6.11. Social indicators of sustainability. Extensive cattle ranching in Latin America offers fewest job opportunities of all agricultural activities (Source: Howard-Borjas, 1992).**

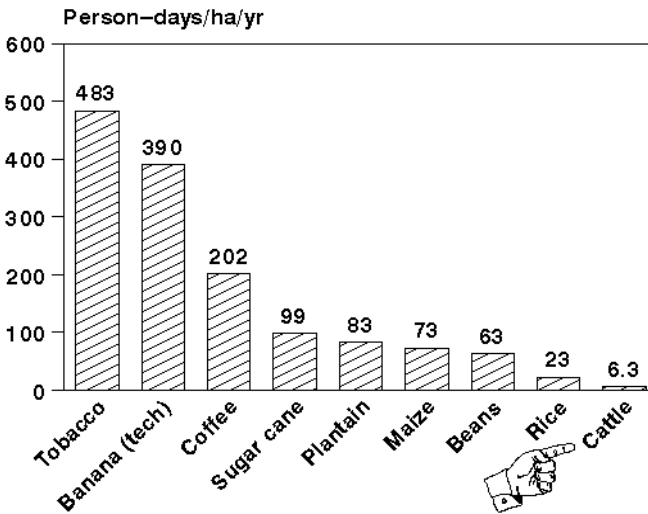

Pasture can be a sustainable land use system only if it is a by-product of food crop production (the Asian model) or is closely integrated with forestry which should be the dominant activity (agroforestry).

Interestingly, when the Asian model was introduced as the alternative (new) livestock production system in the previously eroded "Hado" region, the results were highly successful and have been sustained (Ogle *et al.*, 1993).

Agroforestry has been practised for many decades in industrial plantations of coconuts, rubber and oil palm, primarily as a means of controlling weed and grass growth (Reynolds, 1988; Sanchez, 1995). The limited technologies introduced consisted of planting aggressive legumes such as tropical kudzu (*Pueraria phaseoloides*), but here the aim was more to aid the tree crop than the animal.

The "Alley farming" system of agroforestry developed in West Africa was never intended for grazing animals but for "cut and carry" management, or simply as a source of mulch and fertilizer (Attah Krah, 1991).

The planting of leguminous trees in association with pasture for sustainable production of animal feed is a new endeavour (Molina, C. and Molina, E. 1994, Personal communication: Rodriguez and Cuellar, 1994). In this system trees such as *Gliricidia sepium*, *Leucaena leucocephala* and *Erythrina fusca* are planted at densities in the range 600 to 1100/ha (*E. fusca*), 10,000 to 20,000 (*G. sepium*, *L. leucocephala*) and 25-50/ha (*Prosopis juliflora*), in association with grasses such as star grass (*Cynodon nlemfuensis*) and Argentina grass (*Cynodon dactylon*). The trees are lopped at intervals of 90-120 days in the case of *E. fusca* and *G. sepium*, browsed at intervals of 40-60 days for *L. leucocephala* or left for the fruits to fall and be consumed in situ or collected (*P. juliflora*). As all of this work is on commercial farms, much of the information is derived from observations and in no cases are there strictly comparable control plots (see Chapter 11 for a discussion of this issue). The use of legume trees and other fodder trees as protein sources for livestock was the subject of a recent FAO Expert Consultation (FAO, 1992).

Some recent data on soil fertility in agro-forestry systems are interesting and extremely relevant to the issue of sustainable use of

natural resources. In the examples, one of a protein bank of *G. sepium* (Figure 6.12) and the other with cattle grazing under *E. fusca* (Figures 6.13, 6.14), soil fertility improved over time or in comparison with similar pastures not associated with trees.

**Figure 6.12. Effect on parameters of soil fertility of managing the leguminous tree *Gliricidia sepium* as a protein source for cattle (harvested every 90 days; biomass yield about 80 tonnes fresh foliage/ha/year) (Source: Gomez, M.E., 1992, unpublished data).**

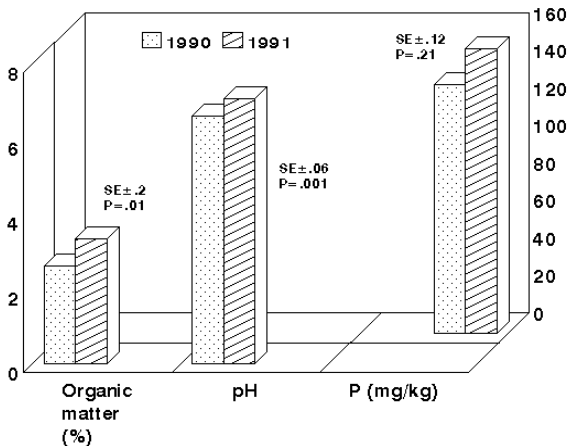

## The nutritive value of pasture associated with trees

### *Effects of shade*

There is a wealth of literature on the composition of grasses, and how this changes under the influence of management including, cutting, grazing, fertilization, and inter-sowing with herbaceous legumes. There is much less information on the effect of shade on pasture productivity and quality (Sanchez, 1995). Work done in industrial tree crop plantations indicates that increasing degree of shade reduces biomass productivity, increases the content of soluble nitrogenous compounds and decreases that of soluble carbohydrates. These changes are likely to have negative effects on both stocking rate and balance of nutrients.

**Figure 6.13. Effect on soil organic matter of managing an association of *Erythrina fusca* (600 or 1100 trees/ha) in association with star grass; trees are lopped at intervals of 90-120 days and leaves fed to housed cattle; star grass is grazed by replacement heifers on a 30 day rotation) (Source: Rodriguez y Cuellar, 1994).**

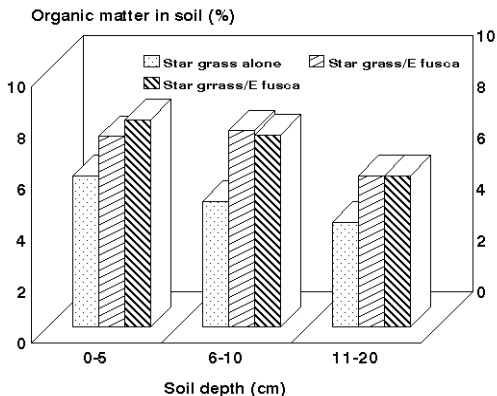

**Figure 6.14. Effect on nitrogen (organic) in soil of associating African star grass with *Erythrina edulis* trees planted at 600 or 1100 per ha (Source: Rodriguez and Cuellar, 1994).**

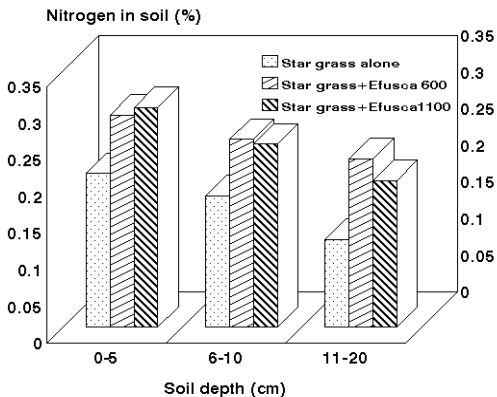

There are no comparable data for associations where leguminous tree crops and grasses are managed for animal feed and where shading is cyclical (i.e., zero immediately after lopping increasing over time to almost 100% shade, depending on the tree population and the harvest interval, which is usually between 90 and 120 days).

### *Supplementation*

If the pasture is young (less than 30-40 days regrowth) then in all probability it will contain adequate amounts of fermentable nitrogen, and minerals and little or no "by-pass" protein. It will also (pasture under shade) be deficient in glucose precursors due to low levels of soluble carbohydrates.

The first priority, in order to increase animal productivity will be the provision of "by-pass" protein. This could be provided by the leaves of the associated trees; otherwise, protein-rich meals from oil or cereal milling should be given. In Mauritius, where dairy cattle are kept in confinement by landless farmers (mostly women), and feed must be harvested from roadsides or sugar cane fields, supplementation with cottonseed meal at only 250g/litre of milk gave the same yield as twice the amount (500 g/litre) of "balanced" concentrates (Figure 6.15).

The second priority will be to increase the supply of glucose precursors. By- product oilseed meals and brans will normally increase the supply of glucose precursors, either via "by-pass" starch or indirectly through increasing rumen propionate.

A more interesting approach, and in line with the strategy of identifying and using truly tropical feed resources, is the use of the crude oil from the African oil palm. "By-pass" oil (protected with calcium salts) is incorporated directly into milk and body fat, thus saving glucose needed for NADPH synthesis when fat is synthesized from acetate (Chapter 5).

This feed resource, which is already being used commercially for feeding to pigs, on several farms in Colombia, promises to have a particular role in complementing tree foliages in the diet of milking cows.

**Figure 6.15. A source of "by-pass" protein such as cottonseed cake is a more economical supplement than "balanced" concentrates for milking cows in confinement fed cut-and-carried grass (wet season) and sugar cane tops (dry season) (Source: Boodoo *et al.*, 1990a).**

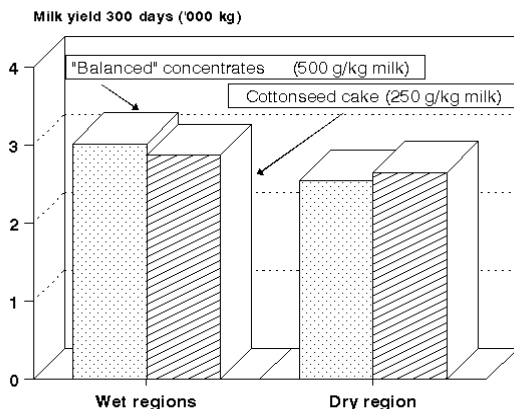

Of special interest is an apparent synergistic effect when the oil is mixed with protein-rich leaves from forage trees which normally are not relished by cattle. The fresh leaves of the tree *Erythrina fusca* are eaten by cattle but not with great relish. Wilting them for 24 hours improved both intake and growth response in crossbred heifers (Cuellar *et al.*, 1992). However, mixing the leaves with 6% palm oil (fresh weight basis) and 2% calcium hydroxide, following wilting, brought about a threefold increase in intake (Rodriguez and Cuellar, 1994). Milk yields and supplement intakes of crossbred Holstein-Zebu cows in three on-farm trials to evaluate the oil/leaves mixture are shown in Table 6.3. Milk production on the mixture of oil and leaves was the same as, or better than, on the control of concentrates (based on oilseed meals and rice polishings).

The optimum amount of any by-pass nutrient-rich supplement for complementing pasture must be determined from a response function curve as was outlined for crop residues above. The data for experiment 3 in Table 6.3 indicate that the optimum amount of oil for the particular

combination of crossbred cows and Star grass pasture was of the order of 350 g daily.

**Table 6.3. Mean values for supplement intake and milk production\* of F1 cows rotationally grazed on African Star grass and given supplements of fresh foliage of *Erythrina fusca* mixed with palm oil (Source: Cuellar and Rodriguez, 1994).**

				SE/Prob
Experiment 1:				
Supplement (kg/d)				
Concentrates	4	2	0	
Foliage/oil	0	4/0.25	8/0.5	
Milk yield (litres/d)	10.4	11.3	11.2	0.16/.001
Experiment 2:				
Supplement (kg/d)				
Concentrates	4	0	0	
Foliage/oil	0	4/0.25	8/0.5	
Milk yield (litres/d)	9.68	9.60	10.2	0.15/0.001
Experiment 3:				
Supplement (kg/d)				
Concentrates	4	0	0	
Foliage/oil	0	4/0.25	5.6/0.35	8/0.5
Milk yield (litres/d)	9.45	8.48	9.23	9.08
				0.17/.001

\* Milk yields adjusted by covariance according to yields prior to introducing the experimental supplements



## Technologies for improving the use of renewable natural resources

*This chapter describes existing knowledge on methods for improving the use of natural renewable resources in integrated farming systems. The methods that are described extend beyond the use of feed resources. The justification for including them in this manual is that sustainable agriculture requires the close integration of tree and food crops, animals and energy in order to make optimum use of the available biomass.*

*Thus the success of the "high-offer" system of feeding crop residues depends on alternative use being made of the rejected parts of the feed. The best way of doing this in many situations will be to use these rejected feed components as fuel.*

*Similarly, where animal manure is an essential feature of the farming system, the capacity to convert feed into manure may have a higher priority than the production of meat or milk.*

*In order to optimize the use of available resources, researchers should be aware of these complementary activities in which livestock play an important role but are not necessarily the principal actors. In many components of these systems, information is lacking which implies that these are fertile areas for research.*

### **FARMING SYSTEMS AND AGRO-INDUSTRIAL PROCESSING**

Feed resources likely to be used by small-scale farmers will be mainly produced on the farm as residues or by-products from other crops. Agro-industry is another source of feed resources, especially when the processing is done at village level.

### Integrated farming systems

Sustainable use of natural renewable resources will be facilitated when the feed is grown, the animals are fed and the excreta is recycled on the farm in ways that minimize the use of imported inputs including energy. Integrated farming systems that embody these concepts are seen in many parts of SE Asia and have developed in response to increasing human pressure on land resources. The simple version of this model is shown in Figure 7.1.

Figure 7.1. Flow diagram of the integrated farming system.

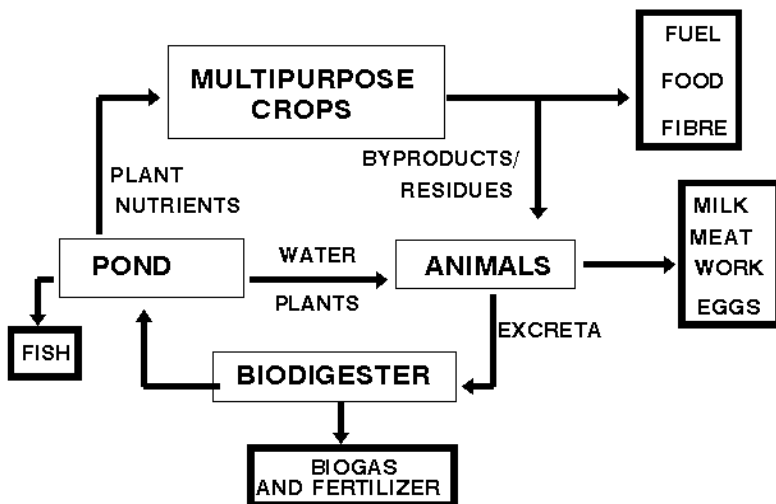

It is proposed to describe the methods already in commercial use which will improve the overall productivity and sustainability of the system.

### Agro-industrial by-products

Processing of agricultural crops can take place on the farm, in the village - usually by some artisan method - or industrially at factory level. Methods will be described which are likely to be useful at the farm and village level.

## MANAGEMENT OF FEED RESOURCES

Two kinds of feed resources are found in practice, depending on the primary crop that is grown. Usually this will be a food or cash crop. In most cases the primary crop will be a cereal grain grown for food security, usually rice in Asia and maize, sorghum or millet in Africa. The residue will then be the stems and leaves which are traditionally left in the field (e.g., in Africa) or carried to the homestead (e.g., in Asia). Examples of cash crops are sugar cane, bananas, cotton, sunflower, groundnuts and various root and tuber crops including cassava and sweet potatoes. Protein crops for home consumption and sale include various types of beans, which frequently are grown in association with cash crops and with maize, sorghum and sunflower. The residues from these crops range from none (the case of jute) to high-protein leaves from cassava and sweet potato and low-protein biomass in the pressed stalk, leaves and the growing point of sugar cane.

From agro-industrial sources, the by-products which will respond to upgrading are: the pulps arising from extraction of juice and slices from pineapple, citrus and tomatoes; the pulp from coffee; cellulosic materials such as sugar cane bagasse; inedible offal from animal and fish processing; organic household and restaurant waste.

Upgrading of crop residues mainly implies the use of technologies to raise digestibility in the case of cereal straws and stover. Other examples of upgrading are methods to neutralize anti-nutritional factors such as hydrocyanic acid in cassava leaves, anti-trypsin factors in soya beans and toxic amino acids and lecithins in *Canavalia* (*Canavalia ensiformis*). In some cases the target will be a monogastric animal (e.g., for cassava leaves) but usually it is the ruminant species that are most appropriate.

Upgrading the feeding value of fibrous crop residues is mostly achieved by interfering with the protective effect of lignin on the availability of substrate to rumen bacteria or to hydrolytic enzymes. While better use of cellulosic roughages can often be achieved by adding a limiting nutrient such as fermentable nitrogen, in the present context, upgrading refers to methods which increase either the rate or the extent of cellulose degradation by rumen micro-organisms. It is important to recognise that upgrading does not necessarily have to result in an increase in digestibility particularly when the roughages in question are

given *ad libitum*. An increase in intake can lead to better use of surplus fibrous feed resources and thus increase performance or decrease the need for supplementation. An increase in degradation rate has the effect of removing digesta more rapidly from the rumen which in turn allows the animals to consume more, without necessarily increasing digestibility.

There are many methods for upgrading fibrous residues but only ammoniation (by urea treatment or with anhydrous ammonia) of straw and high-pressure steam treatment of bagasse are used commercially.

### **Ammoniation**

At the present time the only method recommended for practical application involves ammoniation either using gaseous ammonia or through wet treatment of the material with urea. The effect of this treatment is to increase digestibility (often by 5-10% units), to increase the nitrogen content of the straw (to approximately 1% of the dry matter) and to increase acceptability and voluntary intake of the treated straw as compared to untreated straw (usually by 25-50%) when this is made available on a free choice basis. Only a brief outline of the methods is given here and the reader is referred to recent reviews for more complete descriptions of the method (e.g., Sundstol and Owen, 1984).

#### *The principle*

Ammonia as gas or generated from urea (by bacterial ureases present in the residue) hydrolyzes the chemical/physical bonds between lignin and the cellulose and hemicellulose in the plant cell walls. The hydrolysis of these bonds makes the cellulose and hemicellulose more accessible to micro-organisms in the rumen and increases total fermentation and usually the rate of fermentation. Some chemical hydrolysis of hemicellulose also takes place resulting in an increase in the portion of soluble carbohydrate in the straw.

#### *Wet treatment with urea*

Straw is sprayed with an equal weight of water containing 4-5% urea. This may be done in a pit, in a container such as a basket lined with mud or in the process of building (or re-building) the traditional stack. A garden watering can (or any can with holes punched in the bottom) is convenient for applying the urea solution. If the can contains 20 litres

(800 to 1,000g urea), this will be enough to treat 20 kg of straw. This amount of straw is put into the pit or laid as the base of the stack and the urea solution sprayed on top. The process is repeated until the required amount of straw is treated. In the case of a pit or container, some simple seal such as banana leaves should be put on top. For the stack it is enough to have a final layer of straw arranged in the traditional way for avoiding entry of rain.

For some crop residues (e.g., maize cobs) that have no natural source of urease, it may be advantageous to add a meal containing urease (e.g., from whole soya bean or other legume beans or even livestock excreta which also contains urease). Suggested amounts are 3-5% (dry basis) of the beans or excreta. Additional urease may reduce the reaction time, especially if the fibrous resource appears relatively sterile such as for example, bagasse. The higher the ambient temperature the shorter the time is needed for digestibility to be increased. It is always important to study the reaction time under the local conditions where the straw is to be treated. A minimum of 3 days and a maximum of 14 days is usually required. For a more complete description see Jayasuriya (1984)

Evidence of the reaction taking place is a change in colour of the fibrous material usually to a bright yellow; there is also a strong smell of ammonia when the straw is uncovered. Dark yellow or even brown discoloration of straw may result if the stacks become hot. Treated straw can be fed immediately following ammoniation. It must not be sun-dried as this results in a loss of gaseous ammonia.

#### *The use of animal urine to ammoniate straw*

Animal urine, provided that it comes from animals consuming diets adequate in nitrogen, can be used to provide the source of urea for ensiling with straw. The subject has recently been reviewed (Sundstøl, 1994).

Initially in any system where treatment of straw with urine is to be an on-going technology, it is probably advisable to estimate the quantity of urea in urine and to fortify the urine in the first treatment. From then on the urine ought to contain sufficient urea if the animals are fed on the ammoniated straw. Urine is sprayed on the straw in a similar way to that described above for the urea-treatment method.

### *Ammoniation of straw with gaseous ammonia*

Straw stacks are constructed of a size that can be readily covered by the black polythene sheeting available in most countries. On sandy soils a ground sheet is required. Where large stacks are to be ammoniated, the straw should be sampled and the dry matter content determined. Water should be added to the straw to raise the moisture content to at least 15%. The ammonia-gas cylinder is connected to a long perforated metal pipe about 4 cm diameter which is inserted into the stack through a hole in the plastic about the middle of one end and pushed into the stack (the bales are always stacked so as to facilitate its entry).

The plastic sheet is tied around the tube and sealed along the bottom edges of the stack with earth. A weighed amount of ammonia is then added to give 3 kg of ammonia/100kg of straw. It is always better to inject liquid ammonia and not gaseous ammonia and this is done by inverting the cylinder. The ammonia is rapidly absorbed into water and although the plastic sheet billows it is not likely to rupture. As ammonia inhalation is deleterious to health, it is beneficial to force air through the stacks and trap the excess ammonia prior to opening the stack.

### *Ammoniation with application of heat*

Ammoniation of straws with gaseous ammonia is improved by raising the temperature to 90°C. In Europe, ovens have been developed which take several tonnes of straw and enable the treatment time to be reduced to less than 24 hours. The treatment of straw at these temperature can give rise to toxic compounds which cause "bovine hysteria" and since these compounds are transmitted *via* milk, it becomes hazardous (to calf or human health) to give this type of treated straw to dairy cows (see Perdok and Leng, 1985). The method is not recommended for developing countries.

### **Steam treatment**

Steam at high pressure dramatically increases the digestibility of the bagasse produced when sucrose is extracted from sugar cane at industrial level. The effect is mainly due to acid hydrolysis of the hemicellulose fraction since the digestibility of the insoluble fraction is hardly affected.

The method is especially appropriate for sugar factories where excess high pressure steam is usually available. The fresh bagasse (contains 50% moisture) is held in a steel chamber into which high-pressure steam (17kg/cm<sup>2</sup>) is injected until the temperature rises to 200°C and is kept there for 5 minutes. The pressure is then released abruptly and the material is extracted from the chamber. The treated bagasse takes on a darker colour, has a slightly sweet smell and a pH of less than 4 which enables it to be stored without risk of fermentation. The process also gives rise to toxic phenolic compounds (furfural) if the treatment time is extended much beyond the recommended five minutes.

**Multi-nutrient blocks**

The formula most frequently used for the preparation of multi-nutritional blocks is (kg/100kg of mixture): "C" (final) molasses (minimum Brix 85) 50, urea 10, calcium oxide (or cement) 10, salt 5, bone meal 5 and wheat bran 20. For those persons making blocks for the first time this is a useful starting point as a good firm block will be produced. Mixing may be done by hand, in a concrete mixer or in a horizontal paddle mixer. Choice of one or other method will depend on the relative costs and availability of labour and machinery.

When using a mechanical mixer it is usually recommended to first add the dry ingredients and finally the molasses. When mixing by hand, it is convenient to mix first the urea in the molasses. It is NOT necessary for the urea crystals dissolve in the molasses - it is enough for them to remain suspended in the viscous liquid. Water should not be added. The dry ingredients are then mixed together in a plastic bowl, metal container or wheelbarrow. The molasses-urea is added last. The mixture is then put into moulds made from wood, plastic (a 4 litre bucket is a convenient size) or metal. The mixture should be consolidated in the mould using a weighted plunger. The pressure moulds used to make clay bricks can also be used. Usually the moulds are removed immediately to accelerate drying and curing of the blocks.

Often "final" molasses is not available (it is only produced in the industrial factory) or is unduly costly. There are several alternatives. In most Asian countries, artisan production of "gur" is a traditional and widespread activity. This is often re-processed into crystalline "A" sugar leaving as a residue "A" molasses. The simple centrifuges used for this

purpose require the addition of considerable quantities of water which ends up in the molasses which then will have a final Brix of about 60, and will have lost much of its viscosity. Other replacements for molasses are "vinaza" (distiller's solubles), the scums that are skimmed off boiling cane juice during manufacture of "gur" and "panela" and even fresh cane juice.

The major problem with all these materials is that it is difficult to make blocks of sufficiently hard consistency to limit intake and ensure there will be no risk of urea toxicity which might occur if intake of the block is excessively high.

Experiences in two projects financed by the Technical Cooperation Programme of FAO, first in Cambodia (TCP/CMB/2254; Emergency Plan for Livestock Security [T.R. Preston and C. Kayouli] September 1993, FAO, Phnom Penh), repeated subsequently in Tanzania (TCP/URT/ 2255A, Increasing Livestock Production by making Better Use of Available Feed Resources ([T.R. Preston]. 13 October 1993, Department of Animal Science, Sokoine Agricultural University, Morogoro), have shown that the inclusion of 20% (dry basis) of clay is an effective way of ensuring that a sufficiently hard block will result even when low-brix molasses, vinaza or cane juice are used.

The formula used in Cambodia was: (kg/100 kg mixture) rice bran 35, "A" molasses (Brix 55) 20, urea 7.5, salt 7.5, lime 5, cement 5, clay 20. Twenty kg of clay are mixed with 5 kg of lime and usually water is added in amounts equal to half the weight of the clay. If the clay is wet the amount of water is reduced to one quarter of the weight of clay. As the final activity at the end of the working day, six batches of clay, lime and water are prepared, corresponding to 6 batches each of 100 kg of the final mixture. These are left to soak overnight. The following day the molasses is mixed first with the urea, salt is then added followed by the cement. This mixture is then added to the clay and lime and after thorough mixing is poured onto the rice bran, arranged in the form of a walled circle. The rice bran is then mixed with the liquid component and finally put into individual wooden moulds measuring 20 x 20 x 20 cm, and tightly packed using a weighted plunger.

The mould is then removed and the finished block left to dry in a partially shaded area for a minimum of 4 days. On rainy days, a longer



curing time is necessary. The blocks remain under cover for a further 7-10 days before being distributed to the villages.

In Tanzania the formula was: maize bran 35, final molasses 20, urea 10, clay 20, lime 5, cement 5, salt 5. Four kg of clay are mixed with 1 kg of lime and water is added in amounts equal to half the weight of the clay (i.e., 2 litres).

In the Kondo region of Tanzania, where molasses is difficult to acquire, the scums taken off the surface of the boiling cane juice (during artisan production of syrup) were used instead of molasses. The formula is shown in Table 7.1. In the Amani mountains in Tanzania, fresh sugar cane juice replaced the scums.

**Table 7.1: Formula for multi-nutrient blocks containing the scums from boiling sugar cane juice and with addition of clay to improve gelling characteristics (Source: SIDA-MSc, 1994).**

Ingredient	% Fresh weight	% Dry weight
Scums*	46	16
Clay (dry)	9	14
Urea	4.5	7
Cement	4.5	7
Salt	2.3	3.5
Maize bran	15	23
Sunflowerseed hulls	18	28

\* Juice and flocculated protein and minerals

The urea is first dissolved in the scums or juice. The remaining dry ingredients are mixed separately in a plastic bowl and the scums or juice (containing urea) added last. The final mixture is packed into a mould (a 1 litre can), which is then inverted and the contents ejected carefully to form a cylindrical block, which is then left to dry. The clay acts to adsorb the excess moisture present in the final mixture, thus facilitating the gelling of the block despite its relatively high moisture content (about 40% in the final mixture). When neither molasses nor cane juice is available, blocks can still be made. Examples of formulae without molasses, and descriptions of procedures, used in Tunisia are given by (Hassoun and Ba, 1990).

**High-offer level feeding**

This system is only feasible when more fibrous feed is available than can be consumed by the available number of animals. Feed resources which lend themselves to this method are cereal straws, especially maize, sorghum and millet stover, and the residual pressed sugar cane stalk after juice extraction in a 2 or 3 roll crusher. For best results the level of offer should be at least twice what the animal is able to consume. Urea-containing multi-nutrient blocks should be a feature of this feeding system to supply the necessary nitrogen and minerals. Depending on the feed resource it may be advantageous to chop it or break it into smaller pieces to facilitate the process of selection. Opinions are divided on this issue. Thus, women farmers in Mauritius collect sugar cane tops after harvest of the stalk and offer it whole to their cattle, claiming that this facilitates selection of the more nutritious growing point (Boodoo *et al.*, 1990b). In contrast, Vargas *et al.* (1994) reported a 60% intake of sugar cane tops when these were offered to African Hair sheep at 2 to 3 times the expected intake. The tops had been chopped before feeding.

**NEUTRALIZING ANTI-NUTRITIONAL COMPOUNDS IN FEEDS****Cassava leaves**

Recommended procedures for reducing HCN content to non-toxic levels will depend on the species to be fed. For pigs, ensiling is the simplest method and has given good results in Vietnam (Bui van Chinh, 1994, personal communication). The freshly harvested leaves are mixed with 1% (fresh weight) of rice bran and packed into a pit or other suitable receptacle. Covering with banana leaves weighted down by some heavy objects (bricks or stones) appears to be adequate to ensure anaerobic conditions. A period of three weeks is sufficient to reduce HCN to insignificant concentrations. When the cassava leaves are to be included in poultry rations it is more convenient to sun-dry the leaves for 24-48 hours. This process also reduces HCN concentrations to safe levels (Table 4.8).

For ruminants, the leaves can be fed fresh as the rumen micro-organisms appear to be able to detoxify the HCN.

**Soya beans**

The dry beans contain anti-trypsin factors which interfere with the digestion of the protein in monogastric animals. Industrially, toasting is the standard method for neutralizing these compounds. Toasting can also be done at farm level but it is not always reliable. It is better to boil the beans for 30 minutes following soaking in water the previous 24 hours. Although this method consumes fuel, at least it avoids the need to grind the beans as the soaking and boiling softens them to the point where they are easily digested.

**Canavalia beans**

Beans from the *Canavalia* plant (*Canavalia ensiformis*) contain toxic amino acids and lecithin. The toxic amino acids can be neutralized by treating the beans with ammonia generated from urea by the action of urease present in the beans. Five kg of urea are dissolved in 50 litres of water and added to 100 kg of beans which are then maintained in a sealed container (e.g., a plastic bag) for 7 days. After this treatment, the beans can be fed safely at levels up to 15% of the diet of poultry (Udebibie, 1991).

**Leaves from multi-purpose trees**

The leaves of many species of trees and shrubs contain anti-nutritional compounds such as tannins which, at high levels, can reduce both palatability and digestibility as they form insoluble complexes with the leaf protein. There are three approaches which appear to show promise as a means of improving intake.

High molecular weight compounds such as polyethylene glycol condense with tannins and prevent them reacting with the plant protein. Addition of polyethylene glycol to the drinking water of cattle grazing tanniferous trees in South Africa led to significant increases in growth rate (Leng, R.A., personal communication).

The leaves of *Acacia mangium* have a rumen degradability (*in sacco* method) of only 28-30% in 48hr. Ensiling the leaves with molasses (5kg molasses/100 kg fresh leaves) increased the degradability by 50% (Bui Xuan An *et al.*, 1992). The procedure is similar to that described above for ensiling cassava leaves.

The leaves of *Erythrina fusca*, a leguminous tree used in agro-forestry systems in Colombia (see Chapter 6), is not relished when fed in the fresh state. Wilting the leaves for 24 hours and mixing them with crude palm oil led to threefold increases in intake by crossbred milking cattle. The foliage (leaves, petioles and green stems up to 2cm diameter) are harvested and passed through a forage chopper and left in the shade for 24 hours. Palm oil is added (6 kg oil to 94 kg wilted leaves) and mixed thoroughly with the leaves in a horizontal paddle mixer. The mixture is fed fresh.

It is not known if other tree leaves that are poorly consumed by animals will respond to the same oil treatment. Nor is there an obvious explanation for the effect of the oil in increasing intake. It may act as a "sink" for volatile secondary plant compounds which are responsible for the low palatability. Clearly it is an area worthy of more research.

### **ENSILING FISH AND ANIMAL WASTES**

Fish silage is made from whole fish, or fish offal, that is mechanically ground and liquified by the action of the endogenous enzymes present in the digestive tract of the fish. The addition of acid lowers the pH which inhibits the growth of putrefactive bacteria, enabling long term storage of the silage. There are two approaches: one is to add mineral or organic acids (phosphoric, acetic or formic acid); the other is to add rapidly fermentable carbohydrate (molasses, cassava roots or sweet potato tubers, or a mixture) which ferment anaerobically to acetic acid.

The fish or fish offal is ground as finely as possible, placed in a suitable container and the acid added until the pH falls to 4 or less. The silage is then stored in air-tight conditions until used.

If carbohydrates are used then the amounts are (% by weight): molasses 20, ground fish offal 80 or: roots/tubers 50-30, molasses 10, ground fish offal 40-60. An example of the use of molasses was given by Lien *et al.* (1994) who used a mixture of shrimp heads, blood and molasses in a ratio of 5:3:2 respectively (wet weight).

Molasses can also be used to preserve whole fish or fish or meat offal without grinding (Perez, 1995). In this process, the osmotic pressure of the molasses causes the dehydration of the raw tissue. The fish or offal should be completely covered by the molasses and kept free of air by putting a weighted grid or netting on the surface of the mixture.

### ORGANIC WASTES FROM INSTITUTIONS (CANTEENS, RESTAURANTS, HOSPITALS ETC)

The system used in Cuba for collecting, processing and using organic wastes is described as it represents a unique attempt to develop an alternative non-cereal feed for pigs and at the same time avoid the environmental contamination and loss of resources that results when these materials are incinerated or disposed of in land fills.

**Figure 7.2. Flow chart of system of processing organic wastes for pig feeding in Cuba (Source: Dominguez, 1991).**

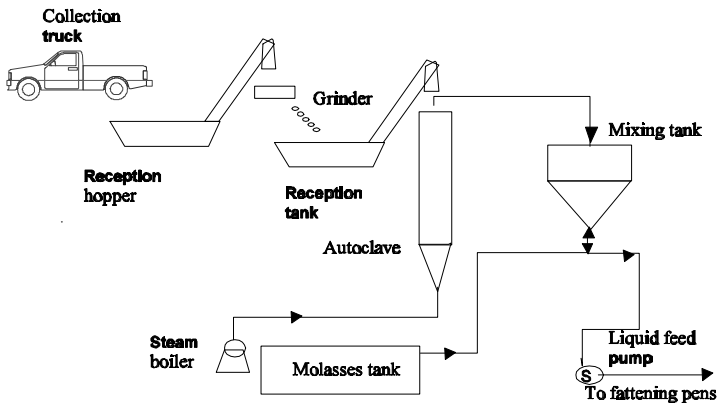

The recovery of these materials is done systematically in tanker trucks which follow established routes throughout the country. In 1990 there were 205 such routes and the average amount of organic waste collected on each one was 7.7 tonnes, giving a total of 1,578 tonnes daily, or close on half a million tonnes annually. The wastes are delivered to industrial plants designed specifically for the purpose of processing the wastes (Del Rio *et al.*, 1980), where they are submitted to selection, grinding, sterilization in an autoclave (121°C and 1.0 to 1.5 atmospheres for 30 minutes) and mixing with sugar cane molasses, before being conveyed by pipeline to pig fattening units (usually of some 12,000 head) situated adjacent (within 200m usually) to the processing plant (see Figure 7.2). Initially, the mixtures used were: (% DM basis) processed organic waste 37, "C" molasses 33 and cereal-based

concentrate 30. Later "C" molasses was replaced with "B" molasses and the concentrates eliminated. The mixture then was: (% DM basis) 30-40 "B" molasses and 0-60 processed waste.

A related development in Cuba was the design of a "thermal destructor" for the processing of wastes from abattoirs and dead animals. This consists of a horizontal autoclave (130°C and 2 atmospheres pressure) with mechanical agitation which converts the wastes into a paste (Dominguez, 1991). The advantage of this system compared with dehydration is the saving in fuel oil (3.7 tonnes less oil are used in wet processing compared with dehydration) and the lower investment cost of the equipment. The paste is conserved with molasses in the same way as used for fish silage .

## **WET PULPS FROM FRUIT AND VEGETABLES**

### **Citrus and pineapple pulps**

A more sustainable method than dehydration for conserving these materials is to ensile them with poultry litter. The poultry litter has two functions: one is to absorb the excess moisture in the pulps; the other is to supply nitrogen and to act as a "buffer" which slows the rate of fermentation, the final effect being to encourage fermentation by bacteria rather than by yeasts. When ensiled without the litter much of the sugars in the fruit wastes is converted by yeasts to alcohol which is of lower feeding value.

Suitable mixtures are in the range of 20-40% poultry litter and 80-60% fresh pulp. The pulp and litter are added in layers in a pit or bunker silo.

### **Waste bananas, cassava roots and sweet potato tubers**

These can be ensiled effectively without the need for additives. They should first be processed into chips which can be done by hand or mechanically. If the material is to be fed to ruminants, then urea will be needed to provide fermentable nitrogen. In this case, the urea can be added prior to ensiling at a level of 3% (dry basis).

## SUGAR CANE

### Industrial processing

The flow diagram of the industrial processing of sugar cane to produce crystalline sucrose is shown in Figure 7.3. The modification of this process to produce "B" molasses requires the elimination of the final crystallization stage such that the "C" sugar remains in the molasses. This "enriched" molasses gives significantly better feed conversion than "C" molasses when the target animals are monogastric species.

**Figure 7.3. The traditional method of sugar cane manufacture can be modified by terminating sucrose extraction at the penultimate centrifugation to produce "B" molasses and no "C" sugar (Source: Figueroa and Ly, 1992).**

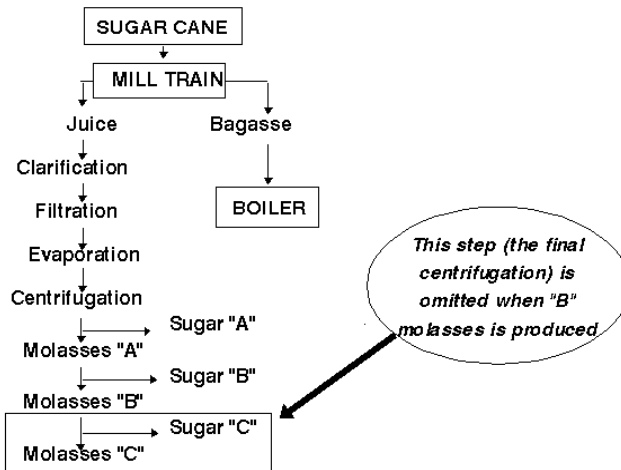

### On-farm fractionation of sugar cane

The flow diagram for the fractionation of sugar cane on-farm to produce: feed for monogastric animals (the juice), ruminants (the tops and residual bagasse) and soil micro-organisms (the trash); and fuel (the residual bagasse) is shown in Figure 7.4. The equipment needed for this process is the same as is used for manufacture of crude brown sugar ("gur" or "panela"). It is easily constructed from scrap metal and gear pinions from broken-down trucks and tractors.

Figure 7.4. Flow diagram of fractionation of sugar cane in a simple 2- or 3-roll crusher.

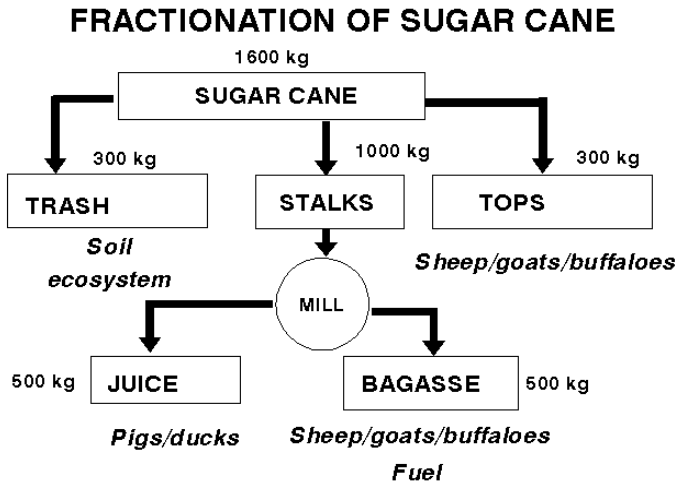

## TECHNOLOGIES TO IMPROVE THE INTEGRATED FARMING SYSTEM

### Low-cost biodigesters

Biodigesters should be an essential component of all farming systems involving the integration of crops and livestock (see Figure 7.1). They produce fuel for the household and thus contribute to environmental protection by reducing the demand for firewood which is the traditional fuel source for the majority of rural people in tropical countries. The effluent from the biodigester is also superior to fresh or conserved animal excreta as fertilizer in fish ponds or for crops.

Despite the emphasis given to the promotion of this technology by national and international institutions, the rate of diffusion is slow. The main reason for this has been the relatively high cost (usually exceeding US\$500 for a family unit) of conventional biodigesters based on Indian or Chinese designs. Low-cost (less than US\$50.00/family unit) plastic film biodigesters, constructed from locally available materials, have recently been introduced in FAO-supported projects in Vietnam,



Cambodia and Tanzania (TCP/VIE/2296, TCP/CMB/2254 and TCP/URT/2255). They have been adapted from the "Red Mud PVC" model, first developed in Taiwan, as described by Pound *et al.* (1981). This model was simplified, using cheaper polyethylene tubular film to replace the welded PVC sheet, first in Ethiopia (Preston, 1985, unpublished data) and later in Colombia (Botero and Preston, 1987). The impact at household level has been dramatic especially with the women. The low-cost biodigester also promises to facilitate the adoption of technologies to improve the nutritive value of fibrous feed resources such as urea treatment and use of multi-nutrient blocks, since increased intake of a better balanced fibrous diet leads to greater quantities of manure of superior nutrient content which is reflected in increased gas production and improved fertilizer value of the effluent.

Details of the model (Figure 7.5) presently being installed in Vietnam have been described by Bui Xuan An *et al.* (1994).

**Figure 7.5.** The essential features of a low-cost polyethylene tubular film biodigester.

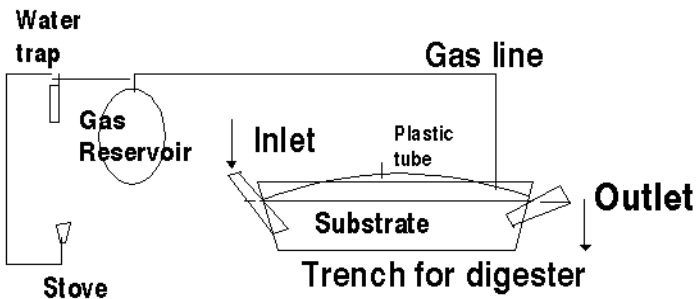

**Materials**

With the aim of minimizing farmers' expenditures and adapting to the local conditions, standard tubular polyethylene film is used as the main component. Factories that produce this material are to be found in principal cities in most developing countries. The choice of supplementary fittings and related materials is limited to those that can be found on farms or in rural markets. The list of materials is given below:

*Biodigester*

- Transparent polyethylene tubular film of 280cm circumference (89cm diameter; thickness about 0.2mm). The thickness can be estimated by the weight of a given length of tube which should normally be 10 kg for 20m of length.
- 2 ceramic tubes of 100cm length and 15cm internal diameter (id).
- 2 m of 21mm id plastic hosepipe.
- 2 PVC adapters (male and female) of 21mm id.
- 2 rubber washers (from car inner tube) of 10cm diameter and 1mm thickness with a 21mm diameter central hole.
- 2 PVC washers of 10cm diameter and 1mm thickness with 21mm central hole.
- 2 m of PVC pipe of 21mm id.
- 5 to 20m of PVC 21mm id rigid tube or flexible plastic hose-pipe (the length depends on the distance from digester to the kitchen).
- 4 waste inner car tubes cut into 5cm bands.
- 1 transparent plastic bottle.
- 1 PVC elbow of 21mm id.
- 3 PVC "T" pieces of 21mm id.
- 1 tube of PVC cement.

*Single stove for cooking:*

- 3 steel tubes of 21mm id, each 10cm long.
- 1 tap of 21mm id.
- 1 metal elbow of 21mm id

**Methodology**

A trench is dug to receive the biodigester. The walls must be firm and the floor must be flat or with only a minimum slope. There must be no sharp stones or protruding roots in the walls or floor.

The cross-section of the trench for a tubular film biodigester of 89 cm diameter has dimensions of 100 cm width at the top, 80 cm width at the bottom and 80 cm depth. The length depends on the amount of manure available. The average is 10 m which requires manure from at least 2 cows or 8 pigs.

Two lengths of the polythene tube are cut, each 11 m long (for 10 m long biodigester), laid on smooth ground, and one inserted into the other.

A small hole is made in the two layers of the plastic tube, approximately 1.5 m from one of the ends. One PVC and one rubber washer are fitted on the flange of the male adapter which is then threaded through the hole from the inside to the outside. A second PVC washer and rubber washer are put on the made adapter from the outside of the tube and secured tightly with the female adapter. The exit of the female adapter is closed temporarily with a small square of plastic film and a rubber band.

A ceramic pipe is inserted to two thirds of its length into one end of the plastic tube. The plastic film is folded around the pipe and secured with 5cm wide rubber bands (made from the used inner tubes). The bands are wrapped in a continuous layer to cover completely the edges of the plastic film, finishing on the ceramic tube. The inlet tube is then closed temporarily with a square of plastic (or a plastic bag) and a rubber band. From the open end, air is forced into the tube in waves formed by flapping the end of the tube. The tube is then tied with a rubber band about 3m from the end so that the air does not escape. The procedure for fitting the outlet tube is the same as for the inlet tube. The complete assembly is then carried carefully to the trench and placed inside. The ceramic tubes are laid at 45° inclination and fixed temporarily.

A safety valve is made from a transparent plastic bottle, a T-piece and 3 PVC tubes (one of 6 and the other two of 30 cm length). Water is poured into the bottle and maintained at 3-5 cm depth (above the mouth of the tube).

The biodigester is filled with water up to two thirds of the depth, moving up and down the outlet (as indicator of the water level inside the tube). The air trapped inside the tube escapes from the safety valve as the volume of water increases.

The gas pipe leading to the kitchen is then attached (it must not be on the ground and the water trap should be at the lowest point in the gas line).

The gas reservoir is made from a length of polyethylene tube (3-4 m) and a PVC "T". It can be located horizontally or vertically but should be shaded from the sun and have a weight (half a brick) suspended from the bottom to increase the pressure. It is fitted into the gas line as close as possible to the kitchen to maximize the rate of gas flow to the burner since the system operates at very low pressure (only 3-5cm water head).

## Chapter 8

# Design and analysis of experiments

*This chapter was contributed by Andrew Speedy, University of Oxford, UK. The objective is to assist researchers to compile and analyze data. To this end, use is made of one of the simpler statistics programs (MINITAB, Minitab Inc., Philadelphia, USA) as the model. More powerful statistical packages may be required for studies in plant and animal genetics and agricultural economics. But, in line with the general philosophy of this manual, it is considered that simplicity and ease of understanding are the principal attributes required of a computer program and, in this respect, Minitab has much to commend it and is therefore selected as the example. But obviously there are various other - often more sophisticated - statistical software packages available on the market.*

## THE OVERALL APPROACH

### The objectives

The most important aspect of conducting good research is the definition of the objective(s). No matter how good the design of the experiment, how sophisticated the methods used or how clever is the statistical treatment of results, the work is of little value if it does not answer a question of scientific importance and practical relevance. Studying the literature, thinking about the questions and discussing them with colleagues, and especially the farmers who will ultimately apply the technology, is the most important part of planning a research programme. Research must be oriented to solving farmers' problems.

### The methodology

Once the objectives are clear, the methodology can be considered. This should be planned to provide the data to answer the questions raised and

to satisfy the needs of the researcher and also others who may wish to adopt the findings and apply them in other situations. It must also be possible within the confines of the resources available (land, animals, buildings, pens, laboratory equipment, etc.). Some of these problems (such as numbers of replicates and land resources) may be overcome by conducting the research 'on-farm', which also has important implications for short-cutting the process of research application or technology transfer.

### **Analysis of the data**

When the data are finally collected, they must be analyzed in a way that will provide meaningful conclusions.

Planning the analysis of the data is part of the initial process of setting up the research programme. Knowing how the data can be correctly analyzed and interpreted will affect how the data are collected and the numbers of observations required. It is often valuable to produce a 'dummy' set of data, calculated on the computer, to test the statistical method.

The following section describes the rules and basic methods for planning, analyzing and interpreting data relating to feed resources and their use by animals.

## **PLANNING, ANALYZING AND INTERPRETING DATA**

### **Statistical programs**

There are many computer packages available for statistical analysis. Throughout this chapter, examples will be given from data analyzed using the package MINITAB which is available for IBM-compatible, Apple Mackintosh and also mainframe computers. The necessary inputs and outputs for this package will be shown. It is taken as an example of a simple yet accurate system for the research worker as well as the student.

### **Management of experimental data**

Collection of data on a daily or weekly basis will yield results that must be used to calculate the variables required for analysis: average daily gain (kg) for each animal, average daily food intake, etc. Such initial calculations (although they may be managed with MINITAB) are best

stored and manipulated with a spreadsheet package such as LOTUS 1-2-3. These data can be read into the MINITAB worksheet by, e.g.

```
RETRIEVE 'WEIGHTS.WK1';  
LOTUS.
```

### **Types of data**

Many of the measurements made in this type of work will be of the kind that are called 'continuous variables': weight, food intake, blood levels, etc. The pattern of variation of such variables conforms to the 'normal distribution'. These can be analyzed by a range of tools called parametric statistics, including regression analysis and analysis of variance.

Certain variables of the type 'success/failure', 'germinated/not germinated', 'conceived/not conceived' are 'discontinuous variables' and the variation conforms to the binomial distribution. Also amongst this type may be records of the type 'class 1, class 2 or class 3', where a measurement 1.1 or 1.2 is not possible. These conform to the Poisson distribution. These data cannot be analyzed by techniques like analysis of variance but require 'non-parametric statistics'. However, in many cases, such data can be 'transformed' using mathematical devices (e.g. logarithm, square root, etc.) to make them conform to a normal distribution. Percentage data should also be transformed.

### **Types of analysis**

Although ANOVAR and regression are well-known techniques, both may be analyzed using a newer method called the Generalized Linear Model (GLM) which has a number of advantages. It fits a 'model' to the data and predicts the means and variance from the model. Equivalent examples of MINITAB instructions are:

```
REGRESS C1 1 C2          GLM C1=C2;  
                          COVARIATE C2.  
REGRESS C1 2 C2 C3      GLM C1=C2+C3;  
                          COVARIATE C2 C3  
ANOVA C1=C5             GLM C1=C5  
ANOVA C1=C5+C6         GLM C1=C5+C6  
No equivalent          GLM C1=C2+C5;  
                          COVARIATE C2.  
No equivalent          GLM C1=C2+C3+C5+C6;  
                          COVARIATE C2 C3.
```

### **Types of variables**

From the above, it is clear that some variables are suited to 'regression analysis' and some to ANOVA. The former are called continuous variables and the latter are discrete variables. Levels of fertilizer, levels of feed protein, etc. are continuous variables and can be analyzed in GLM with the 'COVAR' subcommand. Discrete variables like variety of crop, breed of livestock, etc. are analyzed with ANOVA or the equivalent GLM command.

### **Number of treatments**

The number of treatments which can be applied may depend on what is available and the amount of experimental resources. However, with continuous variables, it is always better to have more levels of a factor where possible. For example, with 30 experimental units, more information on the type of response to a factor will be obtained with 5 levels and 6 replicates than with 3 levels and 10 replicates. Very little is lost in precision whereas much is gained in knowledge about the shape of the response (linear, quadratic or cubic). Thus we can find the maximum or optimum response level of a factor.

### **Numbers of replicates**

An experiment uses a sample of a population as the experimental unit. In general, the more replicates that are used, the greater the difference that can be detected. However, experimental facilities are always limited and therefore it is important to be economical with the use of resources. There overriding rule is never to have less than 3 replicates per (sub-)treatment. A more precise estimate of the numbers required to detect the desired percentage difference with a t-test is given by the formula:

$$\text{Expected difference} = t \times \frac{CV}{\sqrt{r}}$$

where t = Student's t (at given treatment and error degrees of freedom);  
CV = coefficient of variation; and r = number of replicates.

The appropriate CV can be found by finding comparable experiments in published articles in the literature. It may vary between 3-25% in this type of work.



The actual size of the experiment will vary with both the number of replicates and the number of treatments. Fewer replicates are needed in factorial experiments where the overall total is greater. Again, as a general rule, ensure that the design has at least 15 degrees of freedom for error (residual degrees of freedom).

### **Blocks**

Blocking is a way to deal with known sources of variation which may be sites on a gradient of fertility down a slope, different litters of pigs, different farms, etc. Each block contains all treatments with replicates. The analysis enables the variable 'block' to be measured and removed from the error variation, eg:

```
GLM output = block + treatment
```

It is good to block experiments wherever a known source of variation occurs. There is little point in including an interaction between treatment and block because this will be difficult to interpret even if it is significant.

### **Covariates**

Inclusion of covariates in an analysis is another way of taking out known variation. Covariates are continuous variables such as initial weight, initial milk yield, etc. Their use is vital in experiments involving dairy production where it is normal for animals of different ages, stages of lactation and potential yield to be used. The command is:

```
GLM yield = initial + treatment;  
covariate initial.
```

## **ANALYSIS OF CONTINUOUS DATA**

### **Experiments with two treatments**

The simplest experiment compares the results of two treatments. We may wish to compare two or more populations (breeds of animal or varieties of plant) and take samples from each. Our samples must be taken at random and must represent the populations and their variation.

Experiments often involve applying some action or actions to a sample of the population to measure its effect. The sample of the

population is divided and the treatment(s) applied to part(s) of the sample. If we want to know how the treated sample differs from the untreated one, we need to keep the untreated ones as a 'control'. Treatments must be applied at random.

When the data have been collected, we want to analyze the results to compare the two (or more) samples or the treated groups with the control. This is done by calculating the variance and partitioning it between that due to treatment and the natural ('residual' or 'error') variance. The process is called an 'analysis of variance'.

An example involves two treatments (or a treated group and control) with 10 replicates of each. The means of the two treatments are 10 and 11.

```
MTB > PRINT C1-C2
ROW    C1    C2
  1    11.5   9.7
  2    11.6  11.6
  3    10.5  10.9
  4    10.1  10.8
  5    10.2   9.6
  6     9.0  10.7
  7     9.1  12.5
  8     8.5  11.2
  9    10.2  12.6
 10     9.3  11.5
```

```
MTB > TWOSAMPLE C2 C1;
SUBC> POOLED.
TWOSAMPLE T FOR C2 VS C1
      N      MEAN   STDEV   SE MEAN
C2     10     11.11   1.01    0.32
C1     10     10.00   1.04    0.33
95 PCT CI FOR MU C2 - MU C1: (0.15, 2.07)
TTEST MU C2 = MU C1 (VS NE): T= 2.43  P=0.026  DF= 18
POOLED STDEV = 1.02
```

### *Explanation:*

The data consist of two sets of values (two treatments) stored in C1 and C2. These are listed with the MINITAB command 'PRINT'. Then the data are compared using a 't-test' with the command 'TWOSAMPLE'. The printout shows the means, standard deviations and standard error of the means and calculated t value. The probability value of 0.026 is less

than 0.05 and therefore the null hypothesis that C2 is NOT different to C1 is rejected, i.e. C2 is significantly greater than C1 ( $P < 0.05$ ).

### Relationships between variables

In some types of data, the objective is to test the relationship between two variables and to produce an equation which describes this relationship. This is frequently done by regression analysis. In the example here, the alternative 'GLM' command (Generalized Linear Model) is used to perform the regression analysis. The example is to test the relationship between OIL and ENERGY in feed samples:

```
MTB > brief 3
MTB > glm Energy=Oil;
SUBC> covariate Oil.
```

#### Analysis of Variance for Energy

Source	DF	Seq SS	Adj SS	Adj MS	F	P
Oil	1	0.26167	0.26167	0.26167	7.94	0.011
Error	18	0.59334	0.59334	0.03296		
Total	19	0.85501				

Term	Coeff	Sdev	t-value	P
Constant	10.9324	0.9046	12.09	0.000
Oil	0.5116	0.1816	2.82	0.011

#### Unusual Observations for Energy

Obs.	Energy	Fit	Sdev.Fit	Residual	Sd.Resid
5	13.9461	13.4981	0.0412	0.4480	2.53R
17	13.6340	13.7359	0.1000	-0.1020	-0.67 X

R denotes an obs. with a large Sd.Resid.

X denotes an obs. whose X value gives it large influence.

### Explanation:

The two variables are stored in columns C1-C2 and labelled Energy and Oil. The GLM model to test is  $C2=C1$  and the subcommand COVARIATE C1 (abbreviated to 'cova C1') tells MINITAB to treat C1 as a continuous variable and not a discrete series of treatments. The probability value ( $P=0.011$ ) tells us that there IS a significant relationship between Energy and Oil ( $P < 0.05$ ) and the equation is given below. Badly fitting data are also indicated. The constant and coefficient of the regression equation are given and the equation can be derived as:

$$\text{Energy} = 10.9324 (\pm 0.9046) + 0.5116 (\pm 0.1815) \text{ Oil}$$

When more than two variables are involved, these may be included in the model to give a multiple regression analysis. Only significant factors should be included in the equation. The COEFFICIENT OF DETERMINATION ( $r^2$ ) is found by dividing the  $SS_x$  by the  $SS_{\text{total}}$ . In this case:

$$r^2 = 0.26167/0.85501 = 0.306 \text{ (30.6\%)}$$

(Equations with  $r^2$  less than 70% should not be used for prediction).

### Experiments with more than two treatments.

When more than two factors are involved in an experiment, the technique of ANALYSIS OF VARIANCE can be used. This can also be carried out using GLM with the appropriate model. The following is a simple experiment with three treatments and their effect on live weight gain (LWG). The model is:  $\text{LWG} = \text{Treat}$

```
MTB > table 'Treat';
```

```
SUBC> stats 'LWG'.
```

```
ROWS: Treat
```

	LWG	LWG	LWG
	N	MEAN	STD DEV
1	10	507.38	53.45
2	10	576.98	48.31
3	10	656.45	71.04
ALL	30	580.27	83.75

```
MTB > glm LWG=Treat;
```

```
SUBC> means Treat.
```

```
Factor Levels Values
```

```
Treat 3 1 2 3
```

```
Analysis of Variance for LWG
```

Source	DF	Seq SS	Adj SS	Adj MS	F	P
Treat	2	111286	111286	55643	16.30	0.00
Error	27	92145	92145	3413		
Total	29	203431				

```
Unusual Observations for LWG
```

Obs.	LWG	Fit	Stdev.Fit	Residual	St.Resid
25	775.515	656.455	18.474	119.060	2.15R

```
R denotes an obs. with a large st. resid.
```

Means for LWG		
Treat	Mean	Stdev
1	507.4	18.47
2	577.0	18.47
3	656.5	18.47

*Explanation:*

The TABLE command is used to give the means and standard deviations of the treatments. These are the figures that should be presented in a published paper. Then the GLM test is used as shown to produce the analysis of variance table.

From the results shown it can be seen that the effect of treatment is highly significant ( $P < 0.001$ ). A significant F test must be obtained before it is valid to compare treatments by a t-test.

The final table lists the means and pooled standard deviation of the mean. This is used to test for differences. The least significant difference is  $t \times SE$  of the difference. In cases where there are a reasonable number of replicates,  $t$  will be approximately 2. Therefore differences between means greater than  $2 \times SE(\text{difference})$  are significant. In this example, there are significant differences between all treatments.

**Experiments with blocks**

As was explained earlier, where there is a known source of variation (such as site, farm, litter of pigs, etc.) the treatments should be applied equally to each block and the block taken account of in the analysis. The following example gives the MINITAB printout for an experiment with three blocks and three treatments:

```
MTB > glm LWG=block treat;
SUBC> means treat.
```

Factor	Levels	Values
block	3	1      2      3
treat	3	1      2      3

## Analysis of Variance for LWG

Source	DF	Seq SS	Adj SS	Adj MS	F	P
block	2	19211	19211	9605	3.47	0.044
treat	2	28331	28331	14165	5.11	0.012
Error	31	85916	85916	2771		
Total	35	133457				

## Unusual Observations for LWG

Obs.	LWG	Fit	Stdev.Fit	Residual	Sd.Resid
27	627.328	517.695	19.620	109.633	2.24R

R denotes an obs. with a large sd. resid.

## Means for LWG

treat	Mean	Stdev
1	546.7	15.20
2	604.6	15.20
3	607.7	15.20

In this example, both block and treatment are significant ( $P < 0.05$ ). There are significant differences between treatment 1 and both the other two treatments but not between T2 and T3.

**Latin square design**

A Latin Square is a special sort of block design with symmetrical arrangement of treatments in two directions. It is particularly useful in experiments where numbers are restricted by facilities. Take an animal experiment to measure protein degradability by the nylon bag technique, using 4 fistulated animals. Four feeds (A, B, C, D) are studied and each feed is incubated in the rumen of each animal in turn. The design looks as follows:

Period	Animal			
	1	2	3	4
1	B	A	D	C
2	A	D	C	B
3	C	B	A	D
4	D	C	B	A

The analysis would appear as follows:

```

MTB> table c1 c2;
SUBC> means c4.
ROWS: Row          COLUMNS: Column
      1            2            3            4          ALL
1     42.800      42.900      69.100      49.400      51.050
2     47.400      53.500      47.100      56.800      51.200
3     52.300      61.200      40.500      51.800      51.400
4     61.300      51.200      54.000      39.700      51.550
ALL   50.950      52.200      52.625      49.425      51.300
CELL CONTENTS -
C4:MEAN

```

```

MTB> table c3;
SUBC> stats c4.
ROWS: Feed
      Dg          Dg          Dg
      N          MEAN        STD DEV
1     4          42.575      3.504
2     4          48.525      4.176
3     4          52.300      2.061
4     4          62.100      5.117
ALL   16         51.300      8.138

```

```

MTB> glm dg = row column feed
Factor  Levels  Values
Row     4      1      2      3      4
Column  4      1      2      3      4
Feed    4      1      2      3      4

```

```

Analysis of Variance for Dg
Source DF  Seq SS   Adj SS   Adj MS  F      P
Row     3    0.58     0.58    0.19   0.01   0.999
Column  3   24.81    24.81    8.27   0.32   0.811
Feed    3   812.88   812.88  270.96 10.49   0.008
Error   6   155.04   155.04   25.84
Total  15   993.32

```

### *Explanation:*

The analysis shows a significant effect of feed ( $P < 0.01$ ); the table of means is given at the top of this page, together with their standard deviations.

In general, a 4x4 (or better, a 6x6) latin square is suitable for this type of experiment. The design can be chosen at random from lists of latin square designs in statistical textbooks.

### Experiments with interactions

When there are two factors in an experiment, we require to know not only whether there is an effect of each factor alone but also whether there is an INTERACTION between them (one factor affects the response of the animal to the other). This can be analyzed using GLM by specifying the terms:

```
MTB> GLM Y = A B A*B
```

Alternatively, the above expression can be abbreviated to:

```
MTB> GLM Y = A ! B
```

The following example refers to an experiment with three energy treatments and three protein treatments.

```
MTB > table 'energy' 'protein';
SUBC> stats 'LWG'.
```

	ROWS: Energy			COLUMNS: Protein	
	1	2	3	ALL	
1	3	3	3	9	
	513.11	636.95	650.69	600.25	
	50.23	63.41	35.10	79.06	
2	3	3	3	9	
	640.75	650.09	711.54	667.46	
	65.69	18.29	22.36	48.96	
3	3	3	3	9	
	649.58	737.08	627.28	671.32	
	40.65	59.81	54.66	67.68	
	ALL	9	9	27	
	601.15	674.71	663.17	646.34	
	80.60	64.84	50.98	71.94	

```
CELL CONTENTS --
          LWG:N
          MEAN
          STD DEV
```

```
MTB > glm LWG = energy ! protein;
SUBC> means energy ! protein.
```

Factor	Levels	Values		
Energy	3	1	2	3
Protein	3	1	2	3



## Analysis of Variance for LWG

Source	DF	Seq SS	Adj SS	Adj MS	F	P
Energy	2	28746	28746	14373	6.12	0.009
Protein	2	28172	28172	14086	6.00	0.010
Energy*Protein						
Protein	4	35364	35364	8841	3.76	0.021
Error	18	42287	42287	2349		
Total	26	134569				

## Means for LWG

Energy	Mean	Stdev
1	600.3	16.16
2	667.5	16.16
3	671.3	16.16
Protein		
1	601.1	16.16
2	674.7	16.16
3	663.2	16.16
Energy*Protein		
1 1	513.1	27.98
1 2	636.9	27.98
1 3	650.7	27.98
2 1	640.7	27.98
2 2	650.1	27.98
2 3	711.5	27.98
3 1	649.6	27.98
3 2	737.1	27.98
3 3	627.3	27.98

*Explanation:*

Both energy and protein have significant effects. In addition there is a significant interaction between energy and protein, that is, the effect of one is mediated by the effect of the other.

**Introducing covariates**

Another known source of variation may be a continuous variable such as previous milk yield, starting weight, previous performance, etc. This is very often the case in milking experiments with cows or goats when the experimental animals will almost certainly have different yields and be at different stages of lactation. The following example is an experiment with three treatments to measure the effect on the milk yield of cow. Initial yield is stored in the data table as the variable 'init' and the analysis is as follows:

```
MTB > glm yield=treat;
SUBC> covar init;
SUBC> means treat.
```

Factor	Levels	Values
treat	3	1 2 3

#### Analysis of Variance for yield

Source	DF	Seq SS	Adj SS	Adj MS	F	P
init	1	274.56	250.30	250.30	55.75	0.000
treat	2	44.08	44.08	22.04	4.91	0.014
Error	32	143.66	143.66	4.49		
Total	35	462.31				

Term	Coeff	Stdev	t-value	P
Constant	2.3086	0.9055	2.55	0.016
init	0.9670	0.1295	7.47	0.000

#### Means for Covariates

Covariate	Mean	Stdev
init	6.438	2.789

#### Adjusted Means for yield

treat	Mean	Stdev
1	7.100	0.6121
2	8.695	0.6130
3	9.808	0.6150

### *Explanation:*

If the analysis had been performed without including initial milk yield as a covariate, no significant differences between treatments would have been found. However, with the inclusion of the term 'init' as a covariate, there is a significant effect of treatment ( $P < 0.05$ ).

The final table of means shown are the values for each treatment adjusted for initial milk yield. Treatment 1 again differs significantly from the other 2.

### **Better experiments (more levels of the treatments)**

In many feeding experiments we need to test the effects of the level of feed inclusion or of the level of a nutrient such as energy or protein. All the experiments described above have 3 treatments and the treatments are treated as DISCRETE variables. However, we often want to know the SHAPE of the response to a treatment, whether there is a maximum or optimum level. With 2 or 3 treatments we can only see if there is a

response. By including more levels of the treatment we can test the linear, quadratic and cubic effects. That is, we can see if the response is curved. We can also find the equation which describes the curve. To do this, we treat the factors as CONTINUOUS variables. As a general rule, it is better to include more levels of treatments in this type of experiment as we obtain more information about the response. We make better use of the available experimental material and, provided we have a reasonable number, we lose very little in precision (only 1 degree of freedom for each level). The following is an experiment with 5 levels of energy and 5 levels of protein. We can test for the response to both and also for the interaction between energy and protein.

```
MTB > table 'Energy' 'Protein';
SUBC> stats 'LWG'.
ROWS: Energy          COLUMNS: Protein
  1          1      2      3      4      5      ALL
  3          3      3      3      3      3      15
  522.31  522.62  565.98  535.65  596.00  548.51
  20.46   32.52   18.15   29.77   48.59   39.96
  2          3          3          3          3          3          15
  555.63  564.93  631.32  638.35  643.72  606.79
  28.50   23.54   19.19   29.58   18.51   44.64
  3          3          3          3          3          3          15
  558.41  620.30  638.36  646.82  641.30  621.04
  5.65    25.63  41.76   8.58    27.69  40.03
  4          3          3          3          3          3          15
  621.73  664.42  673.26  666.18  667.57  658.63
  30.48   34.30   36.86   26.19   36.15   33.97
  5          3          3          3          3          3          15
  616.58  667.53  690.55  698.05  691.20  672.78
  17.21   4.94    14.17   9.19    36.06   35.10
  ALL     15     15     15     15     15     75
  574.93  607.96  639.89  637.01  647.96  621.55
  43.91   62.68   50.47   59.79   44.08   58.05
CELL CONTENTS --
LWG:N
MEAN
STD DEV

MTB > glm LWG=Energy Protein Energy*Energy Protein*Protein
Energy*Protein;
SUBC> cova Energy Protein;
SUBC> test Energy Protein Energy*Energy Protein*Protein
Energy*Protein /error.
```

## Analysis of Variance for LWG

Source	DF	Seq SS	Adj SS	Adj MS	F	P
Energy	1	135343	18105	18105	22.13	0.000
Protein	1	45991	14473	14473	17.69	0.000
Energy*						
Energy	1	4514	4514	4514	5.52	0.022
Protein*						
Protein	1	6682	6682	6682	8.17	0.006
Energy*						
Protein	1	414	414	414	0.51	0.479
Error	69	56438	56438	818		
Total	74	249382				

Term	Coeff	Stdev	t-value	P
Constant	396.39	26.68	14.86	0.000
Energy	61.38	13.05	4.70	0.000
Protein	54.88	13.05	4.21	0.000
Energy*Energy	4.636	1.974	2.35	0.022
Protein*Protein	5.641	1.974	2.86	0.006
Energy*Protein	1.175	1.651	0.71	0.479

F-test with denominator: Error

Denominator MS = 817.94 with 69 degrees of freedom

Numerator	DF	Seq MS	F	P
Energy	1	135343	165.47	0.000
Protein	1	45991	56.23	0.000
Energy*Energy	1	4514	5.52	0.022
Protein*Protein	1	6682	8.17	0.006
Energy*Protein	1	414	0.51	0.479

*Explanation:*

The first TABLE gives the means for each sub-treatment with standard deviations. The mean for each main treatment is shown at the right hand side and bottom of the table. Then the analysis of variance is performed. Notice that both Energy and Protein are set as continuous variables with the subcommand COVA Energy Protein. Notice also an additional subcommand TEST. This requires some explanation.

TEST is used as a sub-command to GLM to force MINITAB to use the sequential sums-of-squares and consequent mean squares in the test of significance, rather than the adjusted sums-of-squares and mean squares, which is the default action. The difference between them is that the adjusted sum-of-squares refers to each factor when all the others have been accounted for; the sequential sum-of-squares is calculated sequentially from the top so that each factor is taken out in turn.

The TEST sub-command should always be used when the factors are NOT independent, as is inevitably the case with linear, quadratic and cubic effects (X, X\*X, X\*X\*X). In other experiments where the sequential sums-of-squares and adjusted sums-of-squares are very different, non-independence is implied and the TEST sub-command should be used to force the use of the sequential sums- of-squares. The factors tested by the above commands are:

Energy:	linear effect of energy
Protein:	linear effect of protein
Energy*Energy:	quadratic effect of energy
Protein*Protein:	quadratic effect of protein
Energy*Protein:	Energy x Protein interaction.

In assessing significance, the LAST table should be used (F test with denominator: Error). In the example, the linear and quadratic effects for both Energy and Protein are significant but there is no interaction (NS). This shows that the effects of Energy and Protein are curvilinear (diminishing response in this case as the quadratic coefficients are negative).

There is little reason for a farmer to increase either energy or protein above the third level in both cases. An accurate equation can be obtained by rerunning the analysis with the interaction removed (because it was not significant) and using the constant and coefficients to construct the equation.

Note that in experiments with two treatments where we wish to test the interaction, the model can be abbreviated to:

```
MTB> GLM LWG = FEED ! SYSTEM
```

This will test the main effects and the interaction (FEED, SYSTEM and FEED\*SYSTEM). This could not be used in the above example because we excluded some of the more complex interactions.

### **Dealing with unbalanced designs**

Particularly in on-farm research, we may not be able to apply all of the treatments, all of the time. With ANOVA, this presented serious problems and necessitated calculating 'missing plots'. However, GLM

is a powerful tool for dealing with unbalanced designs and has less limitations. A fuller explanation of the use of GLM for unbalanced designs is given below.

### **Some Restrictions on Models in GLM**

*(Minitab Reference Manual 1991, 8-28)*

Although models can be unbalanced in GLM, they must be "full rank." Thus, there must be enough data to estimate all the terms in your model. For example, suppose you have a two factor crossed model with one empty cell. Then you can fit the model  $GLM Y = A B$ , but not  $GLM Y = A B A*B$ . Don't worry about figuring out whether or not your model is of full rank. Minitab will tell you if it is not. In most cases, eliminating some of the high order interactions in your model (assuming, of course, they are not important) will solve your problem.

There is another restriction: nesting must be balanced. Suppose A has 3 levels, and B is nested within A. If B has 4 levels within the first level of A, it must have 4 levels within the second and third levels of A also. Minitab will tell you if you have unbalanced nesting.

In addition, the subscripts used to indicate the 4 levels of B within each level of A must be the same. Thus, you cannot use ( 1 2 3 4 ) for the levels of B within level 1 of A, and ( 5 6 7 8 ) for the levels of B within level 2 of A."

## **ANALYZING EXPERIMENTS WITH DISCONTINUOUS VARIABLES**

### **Chi-squared analysis**

The use of chi-squared analysis enables the analysis of experiments involving data of the yes/no type or when the results are counts. Note that in the latter case the absolute data should be used and the results should NOT be converted into percentages.

The data are arranged in 'contingency tables' of the type:

	Germinated	Not germinated
Control	149	51
Treated seed	182	18

The chi-squared statistic is rather like the SS in that it is the square of the difference between the observed result and the expected result (if the results were averaged between the two treatments). We compute a value for each cell, then sum the values for all the cells and compare the value with the value in tables.

$$\text{chi}^2 = \sum \frac{|\text{observed} - \text{expected}|^2}{\text{expected}}$$

If the total chi-squared value is GREATER than the tabulated value, then there is a significant difference between the rows or treatments.

The data should be entered into MINITAB in two columns and the MINITAB command CHISQUARE used as follows:

```
MTB > chis c1 c2
```

Expected counts are printed below observed counts

	C1	C2	Total
1	149 165.50	51 34.50	200
2	102 165.50	10 34.50	200
Total	331	69	

```
ChiSq = 1.645 + 7.891 + 1.645 + 7.891 = 19.073
df = 1
```

Note that for a 2x2 table there is one degree of freedom (only one comparison possible). Look up the tables on the line for 1 d.f.

Chi-squared analysis may equally be used for simple experiments with more than two treatments. A 3 x 2 table has 2 d.f. The degrees of freedom is calculated as: (rows-1) x (columns-1)

It is also possible to have 3 x 3, 3 x 4, 4 x 4..... etc. tables.

The chi-squared statistic behaves like normal variance in that it may be partitioned between several factors and the interaction may also be calculated. Take the following example:

Four treatments are applied to 100 cows each and the results measured as 'conceived' or 'failed' to conceive:

Treatment	Conceived	Failed
High energy - high protein	81	19
High energy - low protein	88	12
Low energy - high protein	75	25
Low energy - low protein	43	57

First, compute the chi-squared value for the whole table (3 d.f.):  
 Total treatment effect (3 df)  $\chi^2 = 58.549 > 11.3$  significant (P<0.01)

Now combine rows 1+2 and 3+4 into a 2x2 table and calculate chi-squared (1 df) to calculate the energy effect and combine rows 1+3 and 2+4 into another 2x2 table and calculate the chi-squared to test the protein effect:

Energy effect (1 df)  $\chi^2 = 32.080 > 6.63$  significant (P<0.01)

Protein effect (1 df)  $\chi^2 = 7.709 > 6.63$  significant (P<0.01)

Subtract the energy and protein chi-squared values from the total chi-squared to get the remaining effect which is due to the interaction.  
 Energy x protein (1 df)  $\chi^2 = 6.760 > 6.63$  significant (P<0.01)

There is a significant effect of energy and protein, and there is also an interaction between energy and protein. Note how the chi-squared values are additive and we partition the original 3 df into 1 for each main effect and 1 for the interaction.

### Numbers required for chi-squared analysis

(eg: animal reproductive performance)

The numbers required to obtain significant differences in this type of analysis are usually greater than with measurements such as growth or yield. Consider the results of chi-squared analysis where there is a difference of 10% in fertility of cows:



25 cows per treatment

conceived	failed	
20	5	chi <sup>2</sup> = 0.439
18	7	

50 cows per treatment

conceived	failed	
40	10	chi <sup>2</sup> = 0.877
36	14	

100 cows per treatment

conceived	failed	
80	20	chi <sup>2</sup> = 1.754
72	28	

150 cows per treatment

conceived	failed	
120	30	chi <sup>2</sup> = 2.632
18	7	

225 cows per treatment

conceived	failed	
180	45	chi <sup>2</sup> = 3.947
162	63	

It is only when we have 225 cows per treatment that we can detect the 10% difference in fertility ( $P < 0.05$ ), which is an important practical difference.

### **Limitations of chi-squared analysis**

Certain rules must be considered when applying chi-squared analysis. One of these is that all cells should contain values greater than 5 (Snedecor). Otherwise, chi-squared is unreliable particularly with only 1 df.

As an improvement, Yates (1939) proposed an adjustment known as 'Yate's Correction Factor'. This is simply an adjustment of the formula as follows:

$$\text{chi}^2 \text{ adjusted} = \frac{(| \text{observed} - \text{expected} | - 0.5)^2}{\text{expected}}$$

### Exact probabilities

Occasionally it is possible to obtain only limited amounts of data, for example, if to obtain data would destroy experimental units. When the numbers in a 2 x 2 table are very small, it may be best to compute exact probabilities rather than to rely on the chi-squared approximation.

*Example:*

	Have	Have not	Total
Standard	5	2	7
Treatment	3	3	6
Total	8	5	13

We compute the probability of obtaining the observed distribution or a more extreme one, the more extreme ones being:

6	1	7	and	7	0	7
2	4	6		1	5	6
8	5	13		8	5	13

We require the sum of the probabilities associated with the three distributions. Marginal totals are the same for all three tables. The sum of the probabilities will be used in judging significance. The probability associated with the distribution:

$n_{11}$	$n_{12}$	$n_{1.}$
$n_{21}$	$n_{22}$	$n_{2.}$
$n_{.1}$	$n_{.2}$	$n_{..}$

is

$$P = \frac{n_1!n_2!n_3!n_4!}{n_{11}!n_{12}!n_{21}!n_{22}!n..!}$$

where  $n_{ij}!$  is defined as:

$$n! = n(n-1)\dots 1 \text{ and } 0! = 1$$

Read  $n!$  as 'n factorial'.

The probabilities for the three tables above are

$$P = \frac{7! 6! 8! 5!}{5! 2! 3! 3! 13!} = 0.3263$$

$$P = \frac{7! 6! 8! 5!}{6! 1! 2! 4! 13!} = 0.0816$$

$$P = \frac{7! 6! 8! 5!}{7! 0! 1! 5! 13!} = 0.0047$$

The sum of the probabilities is 0.4126 (not significant,  $P > 0.05$ ). It is clear that the computation of the first and second probability alone was sufficient to answer the question of significance. In practice, one uses this approach by computing the largest individual probability first, and so on.

### Other non-parametric tests

Chi-squared analysis can also be used to test whether a distribution conforms to a particular type such as a binomial or Poisson. The calculated distribution is tested against the observed one. Other non-parametric tests which may be required are:

The sign test - for comparing medians.

Wilcoxon's signed rank test - an improvement on the above.

Friedman's test for randomized complete block design.

Wilcoxon's test for completely random design, two populations.

Mann-Whitney test for the same but with unequal samples.

Kruskal-Wallis test for completely random design, any number of populations.

Spearman's coefficient of rank correlation.

Tukey's test of association.

All the above can be used as quick tests without having to make assumptions about the nature of the population, its type of distribution and variance. However, where it is possible to make the necessary assumptions for the use of anovar, etc., more information (on means, variance, etc.) will be obtained.

### **Transforming non-normal data for analysis**

To use the analysis of variance, we have to confirm the assumptions that:

1. Treatment and environmental effects are additive.
2. Experimental errors are random, independently and normally distributed about zero mean and with a common variance (i.e. the data are of the 'height' or 'weight' type).

Violation of these assumptions may result in unreliable statistical tests and the unacceptability of the conclusions (particularly for publication). Data which consist of counts and percentages, in particular, do not conform to these requirements. We can use the non-parametric tests (such as chi-squared) but these give us less information on treatment effects. A solution is often to 'transform' the data to conform to a normal probability distribution. For this, we take the original data, apply a formula and carry out anovar on the transformed data. We do NOT convert the data back to present the statistics but state that the data were transformed before analysis. The following techniques apply:

#### *Square root transformation*

When data consist of small whole numbers, e.g. number of plants or insects of a stated species in a given area, they often conform to the 'Poisson distribution', for which the mean and variance are equal. The analysis of such numbers is often best done by first taking the square root of each observation ( $\sqrt{x}$ ) before carrying out the anovar.

Percentage data based on counts and a common denominator, where the range of percentages is 0-20% or 80-100% (but not both), may also be analyzed using  $\sqrt{x}$ . Percentages between 80-100 should be subtracted from 100 before the transformation is made.

It can be seen that when there are mostly low counts with a few very high ones, the probability will be skewed and taking the square root will pull in the high 'tail'. Notice also that this type of data will have a fixed end, 0 (or 100% in the case of high percentages) which prevents it from showing a two sided normal distribution shape.

When very small values are involved,  $\sqrt{x}$  tends to overcorrect and  $\sqrt{(x+0.5)}$  should be used when some of the values are  $<10$  and especially when zeros are present.

#### *The logarithmic transformation*

The logarithmic transformation ( $\log_{10} x$ ) is used with positive integers which cover a wide range. This will again pull in a high 'tail' particularly when the high values are 100's or 1000's. When values are low (and obviously with 0),  $\log(x+1)$  should be used. (The log transformation is also appropriate in experiments in which the variable is the variance.)

#### *The angular transformation*

The angular transformation ( $\arcsin \sqrt{x}$  or  $\sin^{-1} \sqrt{x}$ ) is applicable to binomial data expressed as a decimal fraction or percentages when the percentages cover a wide range. ( $\sqrt{x}$  was recommended for percentages 0-20 and 80-100. For percentages 30-70 it is doubtful if any transformation is required.) Data may require to be divided by the numerator or 100 in the case of percentages to produce the decimal fractions required.

Classical binomial data are the 'success or failure' type variables - conception rate, germination rate, etc. When given as a proportion, the angular transformation is appropriate. The square root may be applied when they are given as percentages (80-100%).

It is not always obvious which type of transformation is required. It may be helpful to plot the data and data transformed by various methods to check the effect on the shape of the curve.

**SIMULATING EXPERIMENTAL DATA**

The data referred to here are not real. They were produced by simulation, using MINITAB to produce sets of random data conforming to normally distributed probabilities and with appropriate variance.

This can be a very useful technique, used to run the experiment in a theoretical way (using appropriate means and SE's obtained from previous experience or the literature). We can then try the statistical analysis before the experiment starts and identify and limitations in the design.

The appropriate MINITAB commands to create a set of 20 normally distributed data, with mean 10 and  $SD \pm 1$  in column 1, are:

```
MTB> RANDOM 20 C1;  
MTB> NORMAL 10 1.
```

We might do the same in C2, with mean 12 and  $SD \pm 1$  and perform an ANOVAR on the two columns.

The technique can be used to simulate factorial experiments, randomized block designs, latin squares, etc., using appropriate columns for different effects and variances. These can be summed to produce the simulated values for the data column and the appropriate analysis performed.

It is a good method to 'practise' statistics, while gaining an appreciation of the effects of numbers, different levels of variation and different methods of analysis.

## Chapter 9

## Biological and chemical analytical methods

*This chapter describes methods of analysis that are appropriate for characterizing nutritional attributes of feeds. Two approaches are used: one is biological and the other is chemical. Biological methods have advantages where laboratory facilities are minimal since they require little more than a weigh scale and a drying oven and materials that can almost always be acquired in village and city markets.*

*The chemical methods that are described are those considered to be most relevant in the light of developing knowledge on the characterization of tropical feed resources. They relate closely to the criteria discussed in chapters 3 and 5 concerning the nutritional principles underlying utilization of tropical feed resources by monogastric and ruminant livestock.*

*The section on the in sacco nylon bag method was contributed by E.R. Ørskov; that on the in vitro gas production by Kamal Khazaal; and the one on purine analysis by X.B. Chen, all of the Rowett Research Institute in Scotland. M. Rosales and Chris Wood, of the Natural Resources Institute, Chatham, UK described the modification to the gas production technique based on the original proposal by Theodorou et al. 1994. M. Rosales also contributed the section on tannins and described the quantitative methods for identification of a range of secondary plant compounds in plants.*

### INTRODUCTION

It is not intended to provide a comprehensive description of all analytical methods used in animal nutrition research. The aim is to identify those procedures considered to be more applicable and critical to the characterization of feed resources for incorporation into livestock feeding systems in developing countries. Emphasis is given to methods which

are least demanding in terms of sophisticated facilities and equipment.

The measurements are the minimum needed to enable researchers to acquire the essential information for them to set up meaningful feeding trials. Observing and measuring animal response to dietary manipulation on the available feed resources are essential first steps in the development of feeding systems for application on farms. This is the correct order of priorities for allocation of resources aimed at development of animal feeding systems. Too often the research is "bogged down" in the laboratory without excursion into the field, which is a necessary prelude to any study of farmers' problems and finding possible solutions that might fit into existing farming systems (see Chapter 11).

The approach is aimed at resource persons working in national institutions and in non-governmental organizations (NGOs) but the methods are also applicable to international research centres. Obviously there is a special role for the latter and they require many more tools in their research. Their task must be to examine, in depth, the problems that arise in the field and which are generated by the pragmatic "local" approach that is advocated. Such centres should support national institutions, and NGOs, and be engaged in the more sophisticated basic studies that such research requires. The proposed research methods relate closely to the guidelines for utilization of feed resources set out in Chapters 4 and 6.

## **BIOLOGICAL METHODS**

### **Rumen fistulation**

Animals with rumen cannulae have proved to be one of the most useful tools for evaluation of feed resources and especially for determining the effect of a feed on the rumen environment, which has a major influence on the processes of digestion. The technique can be criticized on the grounds that it is an interference with the normal functioning of the animal and that if not carefully maintained the fistula and the cannula can be a source of stress. *In vitro* methods of gas production promise to be an appropriate alternative for measurement of the fermentation potential of a feed and of the relative effect of anti-nutritional compounds present in many tropical feed resources.



For the moment, animals with rumen cannulae will continue to be required as they represent one of the most useful tools available to researchers in developing countries. However, they are not indispensable, and alternative approaches should be developed and used wherever possible.

**Figure 9.1. Illustration of rumen fistula produced by the one-step method of Schalk and Amadon.**

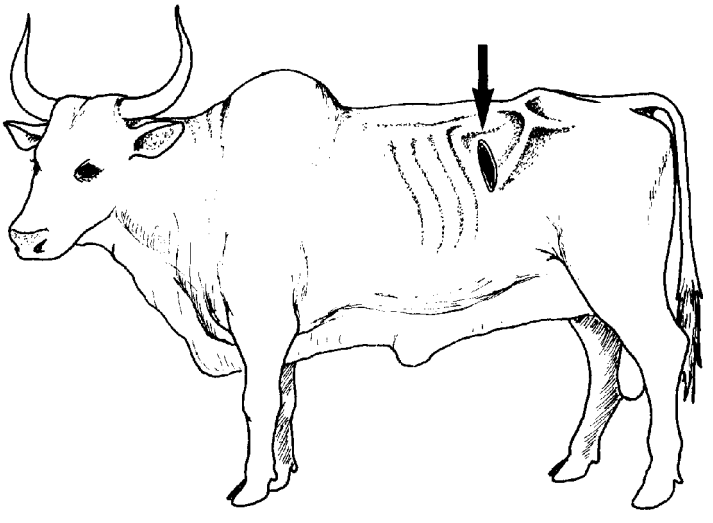

Two procedures for cannulation have been used by researchers. In 1928, Schalk and Amadon described a one-stage surgical technique. A two-step method was developed later by Jarrett (1948), mainly for use with sheep. Both methods have been used but, for unknown reasons, the Schalk and Amadon method seems to have been neglected except in Australia (Hecker, 1974). The surgery associated with establishment of rumen fistulas by the two-stage operation requires considerable skill, is laborious and can be stressful to the animal. The method is extremely difficult to carry out in laboratories that do not have the necessary facilities (e.g., an operating table). Furthermore, it was presumed that

such surgery was the domain of the trained veterinarian. This resulted in "a mental block" for many young scientists, particularly those in developing countries. One result of this has been an undue emphasis on feed analyses as a means of predicting nutritive value of feeds, to the neglect of studies on the live animal. The most appropriate method for establishing rumen fistulas, especially in laboratories with limited surgical facilities, is the one-step Schalk and Amadon procedure.

In the last 10 years in Australia, this technique has been considerably simplified allowing untrained but aware scientists to establish fistulas with a minimum of stress to the animal. For example, in a course at ILCA, in Ethiopia for young African scientists from many backgrounds (all with the mental block concerning surgery), each was able to establish (under guidance) a rumen fistula in either cattle or sheep. The animals that were surgically modified were in the preliminary phase of a feeding trial. Their feed intake was monitored both before and after surgery. The animal ate less on the day of the operation but quickly regained its appetite. With the two stage surgical method, animals go off their feed often for several days.

#### *Principle of the method*

A metal clamp is applied to a fold of the rumen wall exposed by an incision into the body cavity. The clamp holds the fold of rumen wall outside the body, occludes the blood supply and causes the damaged area below the fold to adhere to the body wall. In ten to fourteen days, the clamped piece of rumen 'sloughs off' leaving a fistula through which a cannula can be readily introduced and secured.

#### *Facilities and equipment*

Only minimum facilities are needed; a simple crush or some method of restraining the animal in a standing position (cattle only), a minimum of surgical equipment (scalpel, forceps, etc.), a tranquillizer and local anesthetic. The clamp consists of two brass rods 11 cm long and 0.6 cm in diameter (for sheep) and about twice this size for cattle (Figure 9.3). Each brass rod has two holes 2.5 cm from either end of the rods. The holes in one rod are threaded to take a brass screw which is fitted through a hole in the other rod so that, when the screws are turned, the two rods draw together forming a clamp.

**Figure 9.2. (1) incision with rumen fold pulled through (2) placing wooden clamp on rumen fold (3) inserting sutures along clamped area, and (4) tying sutures (After Johnson, 1969).**

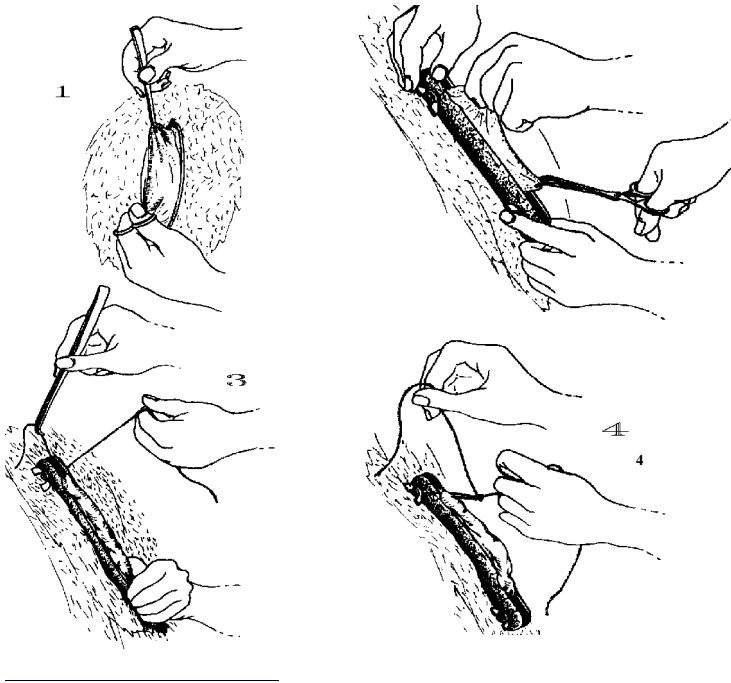

**Figure 9.3. Illustration of the two bars that form the clamp used to hold the exteriorized rumen wall.**

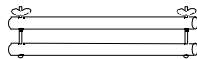

### *Preparation of the animal*

It is not necessary to starve animals prior to surgery; in fact it is desirable to have the rumen relatively full. A tranquillizer given prior to the actual surgery is an advantage in the case of cattle.

The animals should be accustomed to handling by attendants and should be docile and easily led. The surgery is carried out with the fed animal standing in a crush or even restrained in the corner of a yard by a moveable gate. The animal is tranquilized by intramuscular injection (e.g., with Rompun) but this is not absolutely necessary. A 350 kg cow requires about 0.5 ml of Rompun to be sufficiently sedated.

Approximately 15 minutes after the injection of the tranquillizer, surgery may commence. The area of incision should be closely clipped or shaved and cleansed with a mixture of alcohol or alcohol and iodine. The incision should be made high on the left side in the anterior dorsal abdomen. The site of the incision is identified by marking a triangle from the point of connection of the last rib with the spine and moving the same distance along the spine from the last rib. The area between the last rib and where it connects with the spine should be sufficiently large to take the external flange of the cannula. In general the closer to the spine on the flank the incision is made the better; but only experience will allow accurate placing and estimation of size of the incision.

Before starting such operations cannulae of different sizes (5-12 cm internal diameter) should be on hand. Analgesia of the incision area can be produced by paravertebral anaesthesia; however, this requires experience and skill. A more practical approach is to inject a local anaesthetic in a series of subcutaneous and intramuscular injections immediately above and along the site of the incision. Approximately 25 ml of Zylocain is injected into a steer of 250 kg and 15 ml into a sheep.

### *The surgery*

Once the site has been cleaned and disinfected, and the local anaesthetic injected, an incision about 5 cm for sheep and about 10 cm for cattle is made in the ventro-cordal direction through the skin, following the line identified previously.

In the original description of this method the underlying abdominal muscles and peritoneum are separated by blunt dissection to form an

opening in the abdominal wall. This requires considerable physical strength with large animals such as buffaloes and the bold use of the scalpel to cut to the peritoneum is less traumatic to the animal. On reaching the peritoneum, this is cut and the rumen wall which lies immediately below is drawn to the exterior to form a fold and held with two "Alice" forceps. The brass clamp is applied and the screws tightened (Figure 9.2).

Sutures should be placed through the skin and under the clamp and are tied to the clamp at both ends. These sutures hold the clamp to the skin and also prevent accidents which can occur if the rods catch on the sides of the pen. Stitching the skin is one of the most difficult aspects of the operation, particularly with buffaloes, and a sharp cutting needle is needed. In ten to fourteen days the rumen fold held by the clamps will slough off and can be removed quite easily. A flexible rubber cannula or rigid cannula prepared as described below is inserted and clamped into position.

#### **Manufacture of rumen cannulas from locally available materials**

The use of the one-step fistulation technique means that animals (cattle, buffalo, sheep or goats) can be prepared for use in almost any research laboratory. The lack of availability of manufactured cannulas has often been the reason for not preparing fistulated animals. It is relatively simple to devise rumen cannulae for both cattle and sheep. The method described below is taken, in part, from a paper by Rowe (1979).

#### *Available materials*

In most countries PVC conduit is available with diameters from 13 to 300 mm and with a wall thickness of 3-5 mm. In the Dominican Republic, PVC tubing has been used for cannulae which were placed in the fistula of cattle which were subsequently under experimentation for more than two years without apparent problems. Rubber tubing is also available in most countries (e.g., car radiator manifolds) and has been used to prepare cannulae. Car tyres or the protective band from inner tubes usually provide a suitable rigidity for retaining flanges for the cannula.

#### *Construction of cannulae from radiator tubing*

Flexible rubber cannulae are preferred since these can be easily

compressed to introduce them into the oval fistula that results from the method of cannulation.

For sheep, the components of the cannula can be constructed from a section of radiator hose and a round flat piece of rubber cut from a truck tyre. These two parts may be sewn together with nylon thread (as shown in Figure 9.4). Insertion of this cannula into sheep is facilitated by twisting a section of the retaining flange into the tube (see Figure 9.4). When the cannula is in position the retaining flange may be pushed out of the tube of the cannula to allow it to assume its normal shape but inside the rumen.

**Figure 9.4: Rumen cannula for cattle made from rubber components (Source: Rowe, 1979). [1. Main body of cannula, tube and internal flange; 2. External flange 3. Plastic bottle; 4. Hose clamp; 5. Clamped retainer flange made from inner tube 6. Rumen wall, muscle and skin; 7. Tube of cannula - radiator hose; 8. Two flanges - inner tube protector from truck tyre assembly; 9. Continuous stitching with nylon string].**

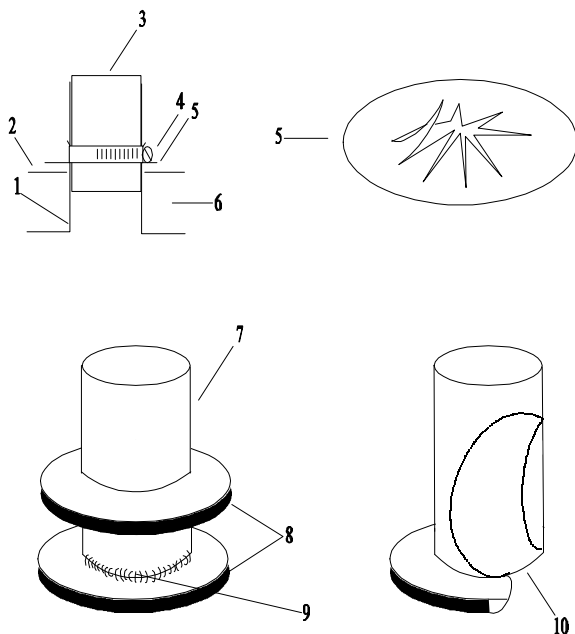

The cannula is held in position with a second rubber retaining flange and this is secured against the body of the sheep as shown. The retaining flange is kept in position by a radiator hose clamp. A suitable stopper for the cannula can be a plastic bottle inverted and inserted with the open end downwards into the tube of the cannula. This is extremely light and causes no problems to the animal.

### *PVC cannulae*

The design of the PVC cannula is shown in Figures 9.5 and 9.6. The PVC tube is prepared with a flange by making cuts of up to 5 cm (for sheep) and 15 cm in length (for cattle) at four intervals around the circumference of the tube. When this is heated uniformly with a gas jet, the plastic becomes pliable and the flanges can be bent outwards at a right angle to the main tube. The flanges can be filed so that there are no rough edges and enclosed in rubber tubing.

**Figure 9.5. Diagram showing the construction of a rumen cannula from PVC tubes and rubber flanges (Rowe 1979).**

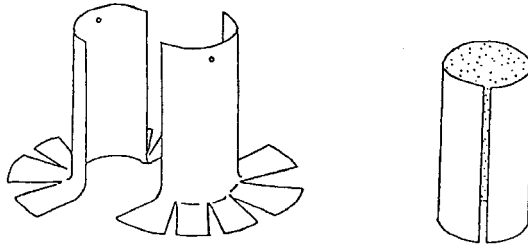

The inner split-tube made from PVC showing the flange (bent out. The outer split-tube made from PVC after heating the material), and the two holes for securing the string tube of the same diameter as the internal tube.

To facilitate placing the cannula in the fistula, it is cut longitudinally in half and a small hole made in each half at the upper end of the flange to attach a length of string. The retaining flanges and the clamping arrangements are prepared as described for rubber cannulae.

**Figure 9.6. Cross-sectional view of PVC cannula. 1. Internal and external flanges (see component 2 of Figure 9.5). 2. Rubber stopper. 3. Inner split-tube of cannula (see Figure 9.5). 4. Outer split-tube of cannula (see Figure 9.5). 5. Clamping assembly. 6. Rumen wall, muscle and skin.**

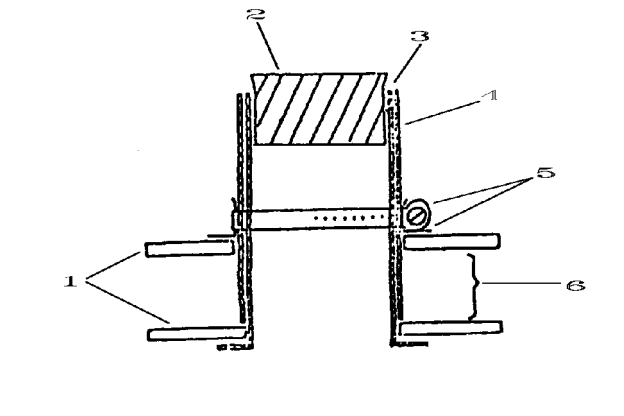

To hold the two halves of the cannula together, an outer split tube is prepared from the same diameter PVC tube but with only a single cut. The cannula is inserted by first putting the two halves (attached to a length of string) into the rumen. The internal retaining flange is then passed around the string and into the rumen, before pulling the two halves together and positioning them in the fistula. The surface of the tube must be thoroughly dried before applying PVC cement and placing the outer split tube in position. The application of PVC cement is not necessary if the tube is clamped close to both the entry of the cannula into the rumen and at the top adjacent to the stopper. A lightweight plastic bottle makes the best seal for the entrance to the cannula. Any size cannula can be made in this way.

#### **Collection of ruminal fluid by oesophageal tube**

For sheep a plastic tube of 10 mm internal diameter and some 90 cm long is suitable. The rumen sampling tube should be moistened and the sheep's mouth opened by placing a thumb in the region without teeth. The tube is then passed over the back of the tongue and into the oesophagus. Test for its presence in the rumen by checking for the smell of rumen fluid, and the lack of respiratory air movements along the tube.



A vacuum pump is used to apply suction to draw the rumen liquid into the sampling bottle.

With cattle, a larger tube is required (15 mm internal diameter and 150 cm long). The rumen fluid can be obtained by lowering the animal's head until fluid runs from the tube. Move the tube in and out a few centimeters in taking the samples. Filter rumen fluid through gauze. Note that samples obtained in this way may be contaminated with variable amounts of saliva.

### **Rumen incubations with nylon bags**

This method is given first priority for researchers in developing countries, as the most appropriate tool for providing information on:

- The nutritive value of a feed for ruminants;
- The efficiency of the rumen ecosystem.

It generates useful information from the point of view of both the carbohydrate and protein status of a feed; and the degree to which it will be digested in the rumen or escape to the intestines. The method is described in detail for this reason.

#### *Characteristics of the bag*

The bags should be prepared from a nylon or other synthetic fibre material with a pore size of between 20 and 40 microns. The pore size is a compromise between minimal loss of small particles and making sure that microbes, including protozoa, can enter the bags uninhibited; and also that gas can escape from the bags. When gas does not escape the bags may float on top of the solid phase of the rumen and give very variable results.

The bags should be sewn with polyester or nylon thread with double seam and close stitching. Overall dimensions for cutting out should be 17 x 10 cm to give an effective length of about 12-14 cm. Smaller bags can be used if samples are smaller. It is not necessary to introduce a draw-string in the neck of the bag, as they can be closed with a separate length of nylon thread (e.g., fishing line), and/or attached to a long nylon string (e.g., baler twine) or a plastic rod (Figure 9.7). The bags can be reused as long as there are no holes in them; each time they should be checked for breakages.

**Figure 9.7: Illustration of plastic tube and attachments of nylon bags for suspension in the rumen.**

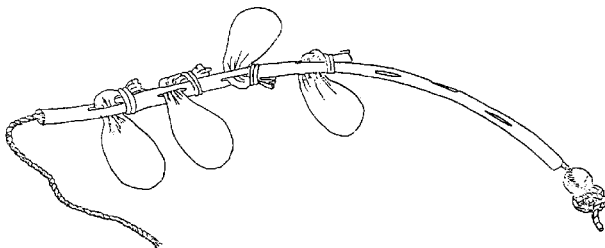

### *Sample size*

The sample size has to be adapted to the size of the bag. With the size of bag suggested, samples of between 3 and 5 g of DM are appropriate. For smaller bags, the quantity should be less, but with a minimum of 2 g. To avoid forming micro-environments in the bag the material has to be able to move freely within the bags. If larger samples are needed for analysis, larger bags must be used.

### *Preparation of samples for incubation*

The preparation of samples must, as far as possible, represent materials as they would appear in the rumen after they have been consumed naturally by the animal. It is recommended that the materials are processed through a hammer mill with a screen size of 2.5 mm; the same screen size can also be used for forages and cereals. For green and succulent materials and silage, a mincer with a 5 mm screen is more appropriate. If the apparatus for grinding materials is not available the sample can be broken down by pounding in the case of dry materials, or by chopping finely with a knife for succulent feeds. It is important to specify exactly what was done in the preparation process.

### *Position of bags in the rumen*

If sheep are used, a 25 cm nylon cord is normally used to attach the bags to the cannula cap. The size of the animals might be considered. In many countries where the sheep and goats are small, it is probably better to use cattle. In cattle, depending on their size, the nylon cord should be about

40 cm. This allows the bag to move freely within the digesta, both in the liquid and solid phases. It is not usually necessary to anchor the string of bags with a weight. Inserting a glass marble or a brass weight in each bag sometimes helps to ensure that each bag is kept well within the digesta. Another method is to fix the bags to a nylon tube (Figure 9.7). This latter system simplifies withdrawal of the bags since bags with individual cords can become tangled and difficult to withdraw from the rumen.

#### *Incubation times of bags in the rumen*

Selection of the most appropriate times to withdraw bags from the rumen depends on the shape of the curve of degradation with time. It is not possible, therefore, to give absolute recommendations. Having tested one material, the test may have to be repeated with slightly different incubation times. It is important to describe the most sensitive part of the degradation curve and also the asymptote. For straw and other fibrous materials, incubation intervals of 12, 24, 48 and 72 hr are usually suitable. For protein meals shorter incubation times should be used (e.g., 2, 6, 12, 24 and 36 hr).

#### *Replication of measurements*

The important source of variation is between animals. There is little to be gained by repeating treatments within the rumens of the same animals. The number of animals needed will depend on the expected magnitude of the differences between treatments. To measure degradabilities of proteins, at least three animals are needed per treatment while, to test the effect of chemical treatment of straw, two replicates (animals) will probably suffice.

#### *Use of sheep or cattle*

If the available sheep weigh less than 40 or 50 kg, it is probably better to use cattle. Cattle are much easier to work with than very small sheep and goats; moreover, it is often convenient to be able to insert a hand directly through the cannula into the rumen so as to introduce, and later extract, the bags more easily.

### Interpretation

Irrespective of whether the results are going to be used for estimation of degradability of protein or dry matter, the most appropriate method of describing the results is in the form of an equation (Ørskov and McDonald, 1979). The expression:  $p = a + b(1 - e^{-ct})$  is the most appropriate equation.

In this equation,  $p$  is the degradation which has taken place;  $a$  is the intercept;  $b$  is the amount which in time  $t$  will be degraded  $c$  is the degradation rate constant and  $e$  is the natural logarithm. If computers or scientific calculators are not available, the equation can be derived by eye.

The procedure is to fit the curve to the measurements obtained in Figure 9.8. It can be seen that the intercept  $a$  is 5; the asymptote is 75 (i.e.,  $a + b = 75$ ) which means  $b$  is 70 (i.e.,  $75 - 5$ ). Taking a value on the curve where degradation is occurring most rapidly (e.g.,  $t = 8$ ) the  $D = 36$ .

**Figure 9.8. Estimating degradabilities of feeds by the nylon bag (*in sacco*) method: calculation of degradation rate ( $c$ ) from disappearance curve fitted by eye.**

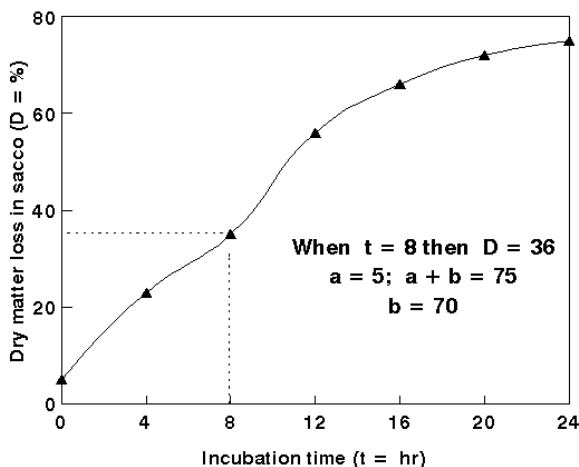

It is now possible to describe the equation as:

$$e^{-ct} = (a+b-D)/b$$

which means that

$$\begin{aligned} e^{-c} &= (5+70-36)/70 \\ e^{-ct} &= 0.557 \end{aligned}$$

By taking the natural logarithm on both sides of the equation it is found that  $c = 0.086$ . All the constants in the equation are now known and they will be found to agree closely with those obtained more accurately with the computer. A computer program on diskette (NEWAY) produced at the Rowett Research Institute is available on request.

### *Effect of outflow rate*

Protein-rich meals, derived from oilseed cakes and by-products from cereal processing and animal slaughter, contain quite a high proportion of small particles which can escape easily from the rumen. The effective rate of degradation of the protein will then depend on the solubility ( $a$ ), the rate at which the  $b$  fraction is degraded ( $c$ ) and the outflow rate from which  $k$  which can be measured by mordanting the protein supplement with chromium. The expression which combines these three factors is:

$$P = a + bc/(c + k)$$

where  $a$ ,  $b$  and  $c$  are from the equation describing degradability and  $k$  is the outflow rate per hr.

### *Characterizing the rumen ecosystem*

The second major use for the nylon bag technique is to measure the adequacy of a diet for a particular purpose. Under these conditions a standard material is put in the bags and the rumen ecosystem varied by supplementation or other means. For example, if the objective is to assess the adequacy of the rumen ecosystem to digest cell wall carbohydrate, then a fibrous substrate with a relatively high potential fermentability (e.g., soya bean hulls) is put in the bags (see Chapter 5 for the application of this method). The effect of supplementing the basal diet (e.g., with urea or highly digestible forage) can be investigated by measuring the relative loss of the soya bean hulls during a 48 hr incubation period.

The other important feature of the rumen ecosystem is the extent to which it permits dietary protein to escape to the intestines. To assess this effect the test protein meals are incubated in nylon bags in the rumen of animals subjected to manipulation of the basal diet by, for example, adding urea or molasses.

### *Evaluation of roughages*

In the case of roughages there is often a lag phase, that is a period in which there is no net disappearance of substrate. This is in part due to the microbial invasion of new substrate (e.g., the cell walls). The consequence for the equation:

$$p = a + b(1 - e^{-ct})$$

is that by extrapolation the  $a$  value can be negative or very small and does not indicate solubility as for instance with protein supplements. In this case, it is useful to determine the water solubility in the laboratory by standard procedures or, more simply, the dry matter loss incurred when the substrate is washed in the nylon bag without rumen incubation using the same procedures as those adopted for washing the nylon bags after incubation. This can be done by two methods: either rinsing under a tap until the water is clear or in a washing machine with a 15 minute rinsing cycle.

In this case, the roughages are best described by: (i) the determined solubility denoted as  $A$ ; (ii) the insoluble but fermentable fraction denoted as  $B$  which is now  $(a+b)-A$ ; and (iii) the rate constant  $C$ . These three parameters have been shown to describe better the degradability characteristics. They can also be used in multiple regression analyses to predict feed intake, or at least the relative feed intake that can be achieved by similar animals. This index of feed "potential" (Ørskov and Ryle, 1992) is only applicable however to feeds that are relatively well balanced for other nutrients (especially fermentable nitrogen). For example, it gives erroneous results with tropical feed resources such as banana pseudo stems and sugar cane. For both these feeds, the stem is more degradable than the leaf but intakes are higher with the leaves, which are better balanced with other nutrients (Montpellier and Preston, 1977; Ffoulkes and Preston, 1978).

### *Limitations to the method*

One of the great advantages of the *in sacco* method is that, unlike *in vitro* methods, it is not dependent on a constant supply of electricity. If need be, the samples can even be sun-dried. There are however feeds which are not suitable to be evaluated by this procedure. For instance, highly soluble feeds such as molasses cannot be assessed in this way.

Some feeds have a very small particle size, such as blood-meal and single cell proteins. The particles of these feeds will pass through the pores of the nylon bags and invalidate the estimate.

It is also appropriate for measuring the presence and effects of antinutritive factors in the feeds which affect rumen microbes. This is because of the vast amount of rumen inoculum in the rumen relative to the small amount of substrate in the nylon bags. The presence of any antimicrobial factors in the feed are swamped by the large inoculum. In this case the *in vitro* gas production test (see later) is much more suitable as the inoculum relative to substrate is far greater. The effect of anti-microbial substances in feeds can be measured by using such feeds as the basal diet or supplement of the host animal and putting in the bags a standard substrate (see Chapter 9).

The *in sacco* method is also unsuitable for measurements of protein degradability in roughages as the microbial N adhering to the particles often exceeds the N in the feed sample.

### **The use of rumen ammonia concentration to determine when urea supplementation is necessary**

The level of rumen ammonia is critical for efficient microbial fermentation of feed (Chapter 5). Rumen ammonia concentration can therefore be used to diagnose a deficiency of fermentable N in a diet. This will indicate when urea supplements are required. The critical ammonia level in the rumen for efficient microbial growth on different substrates is likely to vary according to the fermentability of the substrate.

As a rule of thumb, rumen ammonia nitrogen should be at least 15-20 mg/100ml rumen liquor (see Chapter 5). Where rumen ammonia is to be used as a diagnostic tool then the times of sampling of rumen fluid are critical. It is necessary to synchronize the availability of ammonia with the fermentation of the carbohydrate. The ammonia level at 4 to 6 hours post feeding or following the commencement of grazing is the recommended time for sampling. Ammonia concentrations in rumen fluid must be above the critical level for prolonged periods on fibrous diets which are only slowly digested in the rumen. For this reason the concentration immediately before feeding may also be an index of the need to supplement.

### Assay for by-pass protein in a supplement

Wool growth in sheep is highly dependent on the quality of amino acids absorbed from the intestines, in particular the sulphur amino acids. However, these amino acids are not absorbed other than from the protein (dietary and microbial origin) digested in the intestines. Increased wool growth rate in response to ingestion of a protein supplement is directly related with the content of by-pass protein in the supplement.

#### *Procedure*

Mixed sex, cross-bred wool sheep (the original work was done with 1-year-old Merino x Border Leicester sheep) are housed in individual pens and given *ad libitum* a basal ration of low-nitrogen roughage (e.g., rice straw) plus a mineral mixture and 1% urea (to ensure adequate fermentable-N in the rumen). The sheep are randomized to the treatments (protein-containing supplements) with 10 animals per treatment. In the validation of the method, these were 60g/d untreated casein and 0, 20, 40, and 60 g/d of formaldehyde-treated casein (HCHO-casein) prepared as described later (formaldehyde treatment leads to almost complete protection of the casein from degradation in the rumen). Wool growth was estimated by clipping and weighing the wool from a 10 cm square patch on the flank of the sheep every three weeks (Leng *et al.*, 1984).

Preliminary studies indicated that the carryover effects of diet on wool growth were reduced to insignificant levels after 3 weeks. Trials are therefore carried out for a six week period and only the wool growth in the final three weeks is measured and related to the amount of protein in the supplement. In subsequent studies, the sheep are re-randomized before being allocated to treatments. The data in Figure 9.9 show the results obtained with different levels of formaldehyde-treated casein. The amounts of wool clipped from the patch were linearly related with the level of HCHO-casein added to the basal diet. When soluble casein was added to the diet, wool growth rate was only slightly increased over the control animals indicating that this protein had no by-pass characteristics.



**Figure 9.9.** Wool growth in sheep given a standard basal diet (oat hay and urea) and supplemented with different amounts of casein protected with form-aldehyde. The three experiments were run consecutively. Wool growth was measured during the last 21 days on a 10\*10cm patch (Source: Leng *et al.*, 1984).

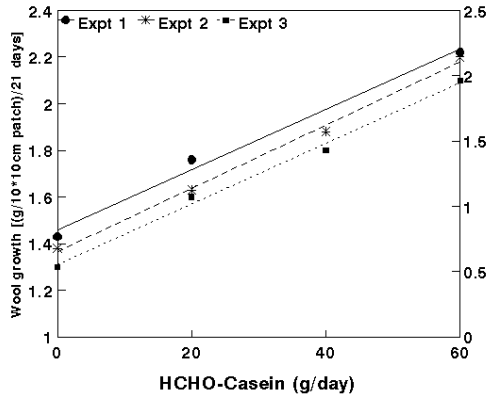

In subsequent experiments, wool weight from the clipped patch in sheep fed 100 g/d protein meal (containing say 40 g protein) was related to the wool grown when HCHO-casein was fed.

Selected results from the use of this assay to evaluate a number of plant protein sources are given in Table 9.1. The wool growth represents the level of by-pass protein relative to formaldehyde-casein. Meals that had received most heat treatment gave the highest wool growth and were therefore the best sources of by-pass protein. Sunflower seed meal was a poor source of by-pass protein, especially when the oil had been extracted by the expeller system. The better by-pass characteristics of the protein in meals produced by the solvent extraction process are because these meals are usually "toasted" at 120°C after the oil is extracted. Similar temperatures may be reached in the expeller process but the results are more variable, as the temperature is produced by friction in the press and this varies with the kind of oilseed being processed.

Feeding trials ranked the protein meals in the same order as indicated by the wool growth assay (Leng R A, unpublished data). In this case the criteria were feed intake and liveweight gain, both of which are good

indicators of the by-pass protein status of a supplement when added to a low-protein diet.

**Table 9.1. Wool growth in sheep given a basal diet of oat hay supplemented with different sources of protein. The feeding trial lasted 42 days and wool growth (on a 10cm square patch) was measured over the last 21 days. Results are expressed as wool growth (g/100g N) (Leng *et al.* 1984).**

	Relative wool growth
Casein	0.3
Sunflower meal	3.3
Rapeseed meal	3.9
Extracted soya bean meal	4.5
Fish meal	7.5
Cottonseed meal	7.2
HCHO casein	10.0
Linseed meal	10.6

*Preparation of formaldehyde-treated casein as a standard for the wool growth assay*

- Place 5.08 kg of casein into a food mixer (a cement mixer is normally used).
- Put 140 ml of formalin (47% formaldehyde) and 240 ml water into a beaker using a measuring cylinder and transfer to a pump fitted with a fine spray.
- Cover with a sheet of plastic the opening in the mixer containing solid casein. The plastic cover has a hole to take the nozzle and add the formaldehyde whilst mixing.
- Put the formaldehyde-casein in plastic bags for a week prior to feeding.

**Biological test of protein quality in non-conventional sources of protein (leaves multi-purpose trees and water plants)**

It has been shown in preliminary experiments (Vargas, J.E. and Sarria, P., 1994, unpublished data) that it is feasible to detect differences in growth rate in male chicks over the period 7 to 13 days of age caused by addition of leaf meals (20% level) to a commercial concentrate diet. As the concentrate contains cereal grain (unbalanced protein) and a varied (and unknown) array of nutrients from unknown sources, the test has been modified to use a protein-free energy source (raw sugar) and a

known source of protein (soya bean meal). In this way, the relationship between chick growth and the protein in the test foliages should be strengthened.

In the test, soya bean meal is used as a standard and the experimental treatments are graded rates of replacement of the soya bean meal with the test foliage. Fibre levels are kept constant by using soya bean hulls. The experiment is done at medium and low overall protein levels so as to identify "additive" effects (or otherwise) of the test foliage. An example of the approach is given below:

#### **Constant protein level (20%); foliage replacing soybean**

Raw sugar	34	34	34	34	34
Soya bean hulls	22	16.5	11	5.5	0
Palm oil	2	2	2	2	2
Foliage (20% protein) (leaf meal)	0	10	20	30	40
Soya bean meal	40	36	32	28	24
Mineral/vitamin mix	2	1.5	1	0.5	0

#### **Varying protein level with soya bean levels as above**

Raw sugar	34	34	34	34	34
Soya bean hulls	22	26	30	34	38
Palm oil	2	2	2	2	2
Soya bean meal	40	36	32	28	24
Mineral/vitamin mix	2	2	2	2	2

Groups of 3 chicks (male rejects of dual purpose laying strains ) are allocated to each of three replicates of each dietary treatment. The trial lasts 14 days, starting at 7 days after hatching: the first seven for adaptation to the experimental diets and the last seven for measurements of weight gain and feed intake. Feed intake is recorded daily. Liveweights are taken at the beginning and end of the 7-day experimental period. The effect of treatment is assessed by regressing body weight gain on level of test foliage (or of soya bean meal in the case of the standard diets without the foliage). The aim of running the standard diets (without test foliage) at the same time is to separate the effects due to protein level and to secondary compounds in the foliages.

### Biological test of soil fertility

Feed resources are generated from the land and specifically from soil and water. To maintain the fertility of soil and, even better, to enrich this basic natural resource, is one of the most important indicators of sustainability. This parameter is obviously a complex one and will depend on many factors both chemical and physical. To analyze the individual components is costly and time-consuming and is not technically nor economically feasible in the majority of tropical developing countries. There are therefore good reasons for developing a simple method which can be performed with minimum inputs and which gives a broad assessment of the capacity of the soil from a given cropping system to support the subsequent growth of another crop.

This issue was addressed in an experiment carried out by CIPAV in Colombia in April-May 1994 (Gomez, M.E., 1994).

About 10 kg of soil (cores taken to a depth of 30cm) taken from the test plot are air-dried and placed in 0.5 litre plastic bags arranged in blocks in the open. Samples are replicated three times in each of four blocks in a random design.

One maize seed was placed in each bag and the biomass harvested 42 days later for fresh and dry weight determination. Adequate moisture was ensured by frequent irrigation. No plant nutrients were used.

The results obtained from a comparison of different cropping systems being evaluated in the Instituto Mayor Campesino, Buga, Valle, Colombia, are shown in Figure 9.10. Details of the cropping systems (from left to right in the figure) are given in the footnote.

Two points can be made. The first is the relatively good repeatability of the test (SE of mean =  $\pm 2.06$ ). The second is the positive effects on soil fertility of the legume trees, *Gliricidia sepium* and *Erythrina poeppigiana*.

It would be useful to include a "standard" soil type in future tests so as to have a reference point that would facilitate comparisons among sites within and across countries. This could be based on sand with three levels of, say, excreta from laying hens or from cattle.

**Figure 9.10. Relative growth rates of maize plants grown in soils taken from a variety of cropping systems producing livestock feed (Source: Gomez, M.E., 1994).**

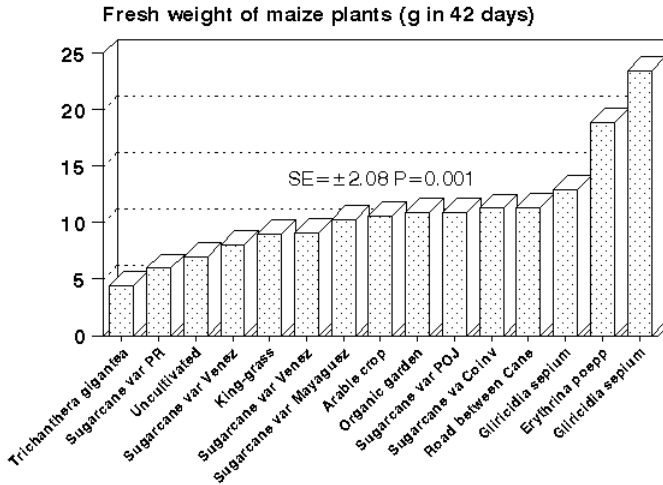

## CHEMICAL ANALYSES

### Estimation of rumen ammonia concentration - field method

The concentration of ammonia in the rumen is one of the most important factors that determine the rate and efficiency of digestion of fibrous feeds (Chapter 5). There are also recent reports that rumen protozoa populations are reduced when rumen ammonia levels are high (Leng R.A., 1994, personal communication).

There are two methods of measuring rumen ammonia which are relatively simple, one of which can be used under field conditions (i.e., the use of an indophenol-dye to produce a colour reaction with ammonia). This method is used by extension officers in Queensland, Australia to predict when urea supplementation through drinking water is likely to be effective in increasing productivity of grazing ruminants (McMeniman, 1981). The method, as modified by Leng (Leng R.A., 1985, unpublished data), is as follows:

*Rumen ammonia kit*

Collection tube

Beaker

1 litre 0.2 hydrochloric acid

Muslin

200 ml sodium salicylate reagent

200 ml dichloroisocyanuric acid reagent (DIC)

Ammonia standards 0, 2.5, 5.0, 7.5, 10.0 mg NH<sub>3</sub>-N/100 ml (These will have already been diluted with HCl).

Test tubes

Test tube rack

Syringes

*Reagents*

- Solution A (Salicylate): Dissolve 85 g of Na and 100 mg of Na nitroprusside in a litre of distilled water.
- Solution B (DIC): Dissolve 5 g of sodium dichloroisocyanurate in a litre of 0.3M NaOH containing 5% commercial bleach (50 ml commercial bleach and 12 g NaOH in one litre of water).
- Solution C (Stock solution): Weigh 3.28 g NH<sub>4</sub>Cl (equivalent to 100 mg NH<sub>3</sub>-N/100 mg) and dissolve in one litre 0.1M HCl (in distilled water).

*Chemical principles*

Ammonia reacts with free chlorine to form chloramine which then condenses with two phenol molecules to form an indophenol dye (strongly reducing compounds in rumen fluid are oxidized by the hypochlorite). Since excessive amounts of both salicylate and hypochlorate are present, the amount of dye produced depends on the amount of ammonia present. The relatively high concentration of salicylate was chosen to "swamp" the effect of any phenolic compounds which may be present in the rumen fluid.

*Obtaining a sample*

- Using an oesophageal tube (see above), obtain 20-30 ml of liquor from the sheep.
- Strain the liquor through four layers of muslin into the beaker.

### *Analyzing the sample*

- Using a syringe or pipette, measure 0.2 ml of the range of standards into labelled tubes, starting with the lowest concentrations and taking care to blow out any fluid left in the syringe between standards.
- Using a plastic syringe for rumen fluid, measure 0.2 ml of strained rumen fluid into a second row of tubes already containing 0.2 ml of 0.1M HCl; blow out the syringe between samples.
- Add 1 ml of the salicylate solution to each tube using a 5 ml syringe.
- Add 1 ml of DIC solution to each tube using a 5 ml syringe; cap and shake to mix.
- Allow 5 minutes for colour development, then add 0.2 ml rumen fluid to all standards; compare samples with standards. Do not allow samples to stand longer than 10 minutes as colour will over-develop.

### Points to note in analysis

- The reagents are relatively stable but they are unlikely to keep indefinitely. If the zero standard is highly coloured then the standards have been contaminated and the salicylate needs renewing.
- If the colour developed in the range of standards is the same, the DIC reagent needs renewing. Add 5-10 drops of commercial bleach to 100 ml of the DIC and repeat the test, before remaking the solution. The standards are in an acid solution and will absorb ammonia from the air, therefore the standards must be sealed at all times and, where analysis appears unreliable, this is the most likely site for investigation. Sampling from 6-8 sheep in a grazing group gives a reliable estimate of the mean rumen ammonia concentration of the group of animals.

## **Laboratory techniques for estimation of rumen ammonia**

### *Principle*

The ammonia is separated from rumen fluid by steam distillation, collected in boric acid solution and determined by titration with standard acid.

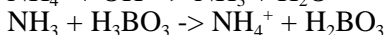
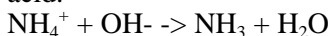

### *Equipment*

Standard steam distillation apparatus is used to isolate ammonia from rumen fluid.

### Reagents

- Ammonium sulphate - a standard solution is prepared from analytical reagent (AR) material and diluted for use.

### Working acid solutions

- 0.05N H<sub>2</sub>SO<sub>4</sub>  
50 ml N H<sub>2</sub>SO<sub>4</sub> standard diluted to 1 litre with distilled H<sub>2</sub>O.
- 0.0075 N H<sub>2</sub>SO<sub>4</sub>; 7.5 ml standard 1N H<sub>2</sub>SO<sub>4</sub> is diluted to 1 litre with distilled water
- Boric acid solution (20%):  
Dissolve 20 g AR boric acid in approximately 700 ml hot distilled water, cool and make 1 litre in a volumetric flask.
- Sodium tetraborate solution (5%) saturated:  
Dissolve 50 g AR sodium tetraborate (powder or crystals) in 1 litre distilled H<sub>2</sub>O
- Universal indicator solution (BDH Chemicals Ltd.)  
Range pH 4 - pH 11 product No. C21049.
- Silicone antifoaming agent (BDH Chemicals Ltd):  
An aqueous emulsion containing 30% Silicon product no. 33151 - use discretely and in extremely small amounts to counter "greasiness" of glass ware.

### Mixed indicator solution

0.1% ethyl red in 85-95% ethanol

0.1% Bromocresol green

40 ml 0.1% methyl red, made up to 2 litres

8 ml 0.1% bromocresol green with 2% boric acid solution

### Preparation and distillation of samples

Strained rumen fluid is centrifuged for 15 min (3000 rpm) and the supernatant frozen after being acidified with 2-3 drops of concentrated sulphuric acid.

Pipette 5 or 10 ml rumen fluid into a distillation flask, add a few drops of universal indicator solution; followed by a small drop of defoaming agent (if necessary) and 10 ml sodium tetraborate solution - distill immediately. Distill until 30-40 ml is collected (about 4 min), remove conical flask and titrate the distillate using 0.1 M HCl. A standard ammonium sulphate should also be titrated.



**Gas liquid chromatography of volatile fatty acids in ruminal fluid**

The total concentrations and individual proportions of the volatile fatty acids in the rumen are an indication of the animal status for glucogenic compounds. Fermentations giving high proportions of propionic acid (25-35%) are desirable since these fermentation patterns are most efficient energetically (less heat is lost as methane). The level of total VFA is also indicative of total fermentation rate. For these reasons a method for VFA analysis by gas-liquid chromatography (GLC) is recommended.

*Column packing*

Inert support: chromosorb 'W', acid washed 50-80 mesh

Liquid phase: (a) phosphoric acid (1.5% by weight of the inert support)  
(b) polypropylene glycol sebacate (PPGS) (18% of the inert support)

*Method*

- 12 g of the chromosorb W are placed into an evaporating basin (12 cm diameter).
- 0.2 g of 88% phosphoric acid ( $H_2PO_4$ ) in 70 ml of distilled water is then added and the mixture gently stirred until the chromosorb W is uniformly wetted.

The mixture is then oven dried at 80°C.

- 2.1 g of PPGS is dissolved in 70 ml of methylene chloride and added to the chromosorb W - phosphoric acid mixture in the evaporating basin and then dried in an oven at 80°C.
- The column is packed using slight suction from a vacuum pump while vibrating the column. Acid washed glass wool is packed into the end of the column then attached to vacuum pump and suction applied. The free running packing is held in a funnel attached to the other end of the column. Vibration or tapping causes the mixture to run into the column.

*Operating procedures*

Operating conditions using FID (Flame Ionization Detector):

Column temperature - 135°C

Detector temperature - 180°C

Injection port temperature - 200°C

Nitrogen carrier gas flow - 60 ml/min

Hydrogen flow to FID - 49 ml/min

Air flow to FID - 400 ml/min

*Preparation of rumen fluid for GLC with an internal-standard*

- Make a stock solution of the internal standard - 1.6% isocaproic acid in formic acid. Store at 4°C.
- Composition of standard VFA (standard A) solution for GLC (mM/litre): Acetic acid 56, Propionic acid 18, Isobutyric acid 3, Butyric acid 9, Isovaleric acid 3, Valeric acid 3.

The concentration of each acid must be known accurately and can vary slightly from that indicated. The mixtures are prepared from AR grade acids and stored neutralized (because a variable loss of individual acids from frozen samples occurs). The formic acid/isocaproic acid, internal standard acidifies the samples prior to injection onto the column. A solution of the internal standard for use (Standard B) over a few days is prepared weekly.

- 10 ml of stock internal standard solution (see Standard A) + 10 ml of 15% metaphosphoric acid (freshly prepared) + 30 ml of formic acid. Store at 4°C.

*Sample preparation*

- Ruminant fluid is centrifuged at 3000 rpm for 10 min
- 0.4 ml of the internal standard solution B is placed into a small (1.5 ml) disposable centrifuge tube followed by 0.7 ml of ruminant fluid. This is mixed and if necessary the sample is again centrifuged at 3,000 rpm for 5 min. These samples can be stored for 1-2 days at 4°C.
- Standards: 0.4 ml of internal standard solution B plus 0.7 ml of mixed VFA standard. 1 to 4 microlitres of this mixture is injected into the column.

*Calculation of total VFA concentration and VFA proportions using the internal standard method*

- The relative response factor (representing the area under the peak of that acid) for each volatile fatty acid is calculated using the standard VFA mixture which is chromatographed in every group of 50 samples, e.g.,  $f_{Ac} = C_{Ac} \times \text{Std A (ic)}/\text{Std.A (Ac)}$  where:  
f<sub>Ac</sub> = the relative response to acetate  
C<sub>Ac</sub> = concentration (μM/ml) of acetic acid in the VFA standard  
Std.A(ic) = area under the iso-caproic acid peak in the standard.

Std.A(Ac) = area of the acetic acid peak in the standard.

Factors are similarly calculated for the other VFAs.

- These factors are used to calculate the individual VFA concentration for each sample.

e.g., Acetic acid = fAc x sample A(Ac) x sample A(ic)

where:

sample A(ic) = area of iso-caproic acid peak in the sample, sample

A(ic) = area of iso-caproic acid peak in the sample.

- The sum of all the individual VFA concentrations for each sample is the total VFA concentration (in  $\mu\text{M}/\text{ml}$  of ruminal fluid).
- By taking the sum of all the individual VFA concentrations as 100% the molar percentage of each acid is calculated.

### **Acetate clearance as an indicator of the balance of absorbed nutrients**

#### *Hypothesis*

It is proposed that in, cattle and sheep, acetate clearance rates reflect the balance of nutrients available for metabolism for a given productive state and that acetate clearance from blood will be directly related with feed intake (Weston, 1966). Accumulation of acetate in blood indicates that there is a shortage of co-factors (NADPH) that are required to incorporate the acetate into lipids at sites of deposition. These co-factors are derived from glucose or its precursors, or from amino acids. If the clearance rate of acetate from the basal diet is slow, this indicates that supplementation is necessary with "by-pass" protein or with glucose precursors.

#### *Method*

Cattle (about 150 kg) are injected with about 2.5 mM sodium acetate per kg liveweight. The injection can be done *via* an in-dwelling cannula in the jugular vein or injected directly into the vein. The injection should be done slowly over about 4 minutes. Blood samples (10 ml) are taken at intervals post injection for analysis of acetate or total VFA.

#### *Injection solution*

Dissolve 30 g of sodium acetate in 300 ml sterile double-distilled water. Inject directly into the jugular vein.

### *Blood samples*

When an in-dwelling cannula is used, this is normally filled with dilute heparin solution (100 units/ml of 0.9% saline) to prevent it being blocked with coagulated blood, and then sealed with a nail. Prior to taking samples, remove the heparin solution and 5 ml of blood from the cannula and discard. Take a further 20 ml of blood into a bottle containing two drops of heparin (3,000 units/ml). Flush the cannula with the dilute heparin solution and seal it. Take samples at 10, 20, 30 and 40 minutes post injection.

### *Chemical analysis*

- Centrifuge blood at 3,500 rpm for 10 minutes.
- Take off the plasma; store 5 ml; use 5 ml for analysis.
- Put into 50 ml centrifuge tubes the following:
  - 20 ml 0.2N H<sub>2</sub>SO<sub>4</sub>
  - 0.4 ml of isobutyric acid (1.75g/litre)
  - 5 ml 10% sodium tungstate
- Leave for 10 min at room temperature.
- Centrifuge at 3,000 rpm for 10 min.
- Put supernatant in a conical flask and add 1 drop of phenolphthalein.
- Neutralize with about 0.5 ml of 3M NaOH (add drop at a time until a pink colour persists).
- Evaporate to about 1 ml by boiling the solution on a hot plate (add glass beads to prevent bumping).
- Add 0.5-1.0 ml of metaphosphoric acid (36% HPO<sub>3</sub>).
- Inject 1-2ul into GLC.  
(See above)
  - H<sub>2</sub> gas flow 30 ml/min
  - Air flow 350 ml/min
  - N<sub>2</sub> carrier gas flow 40 ml/min
- On the GLC set:  
Range 10 Injector temperature 210°C Attenuator 128 Detector temperature 180°C 10mv recorder Column temperature 135°C
- Column: 1.5 m X 4mm ID glass column
- Inert support: Chromosorb W acid washed
- Column coating: 17.5% polypropylene glycol

### *Calculations*

Divide the area of the acetate peak by the area of the iso-butyrate peak to obtain the relative concentration of acetate in blood. Regress the relative concentration of acetate against time from injection and calculate the time for the concentration of acetate to fall to half the value following injection.

### **Chemical analysis of feed and faeces**

#### *Preparation of samples*

Samples of material to be analyzed must be oven-dried at 65°C and then ground to pass through a 1 mm screen. Further drying to constant weight may be necessary to remove residual moisture. Dried material may be stored at room temperature in sealed vessels or plastic bags, preferably under nitrogen gas.

#### *Moisture*

A sample containing the equivalent of about 2 g dry matter is dried to constant weight at 95-100°C for 24 hr. Use an aluminium dish or porcelain crucible. Calculate percentage moisture from the loss in weight (to first decimal place).

#### *Ash*

Weigh a 2 g sample into a weighed porcelain crucible and place in a temperature-controlled furnace preheated to 600°C. Take care to avoid loss of material by convection currents. Hold at this temperature for 4 hr. Transfer crucible directly to desiccator, cool and weigh immediately. Calculate percentage ash (to first decimal place).

### **Kjeldahl Nitrogen determination**

The Kjeldahl technique can be divided into three basic steps:

- Digestion of the sample in concentrated sulphuric acid during which all organic compounds are broken down, and organic N is converted to ammonia.
- Over-neutralization of the solution with a caustic soda solution and distillation and collection of the ammonia.
- Titration of the ammonia.

### *Reagents*

#### 50% Sodium Hydroxide:

Dissolve 600 g of NaOH in distilled water and make up to a volume of 1 litre. When the pellets of sodium hydroxide are added to water, stir with a glass rod. This is necessary to prevent NaOH from fusing to the bottom of the beaker. Keep in a rubber- or plastic-stoppered bottle.

#### Digestion mixture:

Mix 8 g selenium with 400 g potassium sulphate, add the mixture into 2 litres concentrated sulphuric acid and heat until all reagents are dissolved. Note: When the chemicals are mixed the Se and potassium sulphate set solid so it is easier to put the chemicals into the digestion flask and then add the acid. Alternatively, Se catalyst tablets can be purchased and concentrated sulphuric acid is used as the digestion mixture.

### *Sample size*

Determination of sample size assumes some prior knowledge of the material under investigation. For maximum accuracy, a sample size should be taken which will require 10-20 ml of the standard acid. The amount of titrant can also be varied by changing the normality of the standard acid. Some feeds may be low in protein, and it may be difficult with small samples to obtain truly representative samples. Consequently, a considerable amount of dry material must be digested. Using 0.1 M acid as titrant for the ammonia that had been distilled, it is recommended that the following sample sizes are used:

- Dry feed samples 300 mg
- Milk, except colostrum 1 ml (or 1 g)
- Colostrum 300 mg
- Plasma and serum 0.5 ml
- Urine 0.2 ml

Very dilute samples (e.g., rumen fluid) may require use of a 0.01M standard acid for titration. Because of the sensitivity of the analysis, high accuracy cannot be obtained without thorough mixing of the material to be analyzed prior to sampling. This is especially true with materials which have been frozen and allowed to thaw.

### *Digestion*

To the 100 ml Kjeldahl digestion flask, add:

- Sample (approximately 150 mg DM)
- One glass bead to prevent bumping
- 5 ml conc.  $\text{H}_2\text{SO}_4$
- 1 Se catalyst tablet

Heat the mixture on the digestion rack in an area with air extraction. If foaming occurs, the early part of the digestion can be carried out at a lower temperature. Silicone antifoam agents should never be used (contrary to several current texts). The silicone spray coats the sides of the digestion tube producing a non-wetting surface. Large water droplets collect, and when sufficiently large, drop into the superheated anhydrous digestion mixtures, with violent consequences.

Following removal of all the water, white sulphur dioxide fumes will be evolved. These fumes are irritating and toxic and must be exhausted in a hood with sufficient capacity to prevent transfer into the laboratory. During the digestion, charred material can be washed down into the digestion mixture by swirling the digestion flask. If swirling does not flush all charred material into the digestion mixture, let the mixture cool completely and wash the charred material down with a fine stream of water. Then redigest until the mixture clears. After white fumes are no longer evolved and the boiling mixture is clear, allow the digestion to proceed for a further 30 minutes. Then allow the flasks to cool. Add about 20 ml of deionized water and mix immediately to prevent crystallization of the sodium sulphate.

### *Distillation*

This is the same as for ammonia estimation. Turn on the heater under the steam generator and increase the heat to boil the water steadily (not violently) and turn on water to condenser. Put the empty digestion flasks on the collector tubes and, with the alkali stopcock closed and steam directed into the apparatus, run steam through the assembly and collect the condensates in 100 ml beakers for several minutes. This serves to warm up the apparatus, and flush out any residual alkali.

When the apparatus is preheated, open the alkali stopcock and direct the steam into a water drain. Place samples in the distillation apparatus and place 100 ml flasks containing 20 ml 2% (w/v) boric acid (containing indicator) under the condenser stem. Be sure the tip of the condenser stems are below the surface of the boric acid solution. Admit alkali solution through the alkali stopcock (about 5 ml alkali for 1 ml of  $\text{H}_2\text{SO}_4$  used in the original digestion) and close the alkali stopcock. Then turn steam on through the apparatus and allow steam distillation to proceed for 6 min. Near the end of this period, lower the receiving beaker so that the distillate washes any remaining ammonia solution from the tip of the condensing units.

When the distillation is completed, turn steam stopcock into the position which diverts the steam to sink waste and another opens the distillation flasks to atmospheric pressure. Remove distillation flasks and turn steam stopcock to the off position.

#### *Quantification of the ammonia*

Titrate the ammonia-boric acid solution to the pink end-point with standardized acid (0.1N HCl or 0.05N  $\text{H}_2\text{SO}_4$ ). Appropriate blanks must be run and their values subtracted from the sample titration values.

#### *Calculations*

There is a direct mole-per-mole relationship between ammonia released, the acid needed to titrate that ammonia, and the total N originally present. The number of ml of acid multiplied by its molarity gives the millimoles of ammonia. Since the average protein is 16% N, multiplication of per cent N by the factor 6.25 gives per cent crude protein (some factor other than 6.25 may be used for particular proteins).

#### *Precautions*

Care must be taken when working with hot concentrated acid and alkali. Take normal precautions: safety goggles must be worn when starting distillations. In each step where water is added to acid and alkali to acid, the solutions must be cool, otherwise the reactions can be quite violent.



### **The *in vitro* gas production techniques**

*Prepared by: Kamal Khazaal, International Feed Resources Unit, The Rowett Research Institute, Aberdeen ABE 9SB, Scotland, UK*

#### *Background*

In most laboratory techniques used for feed evaluation, the disappearance or solubilization of substrate is measured. On the other hand, the gas production technique, which was originally developed by Menke and Steingass (1988), measures the evolution of gases (methane and CO<sub>2</sub>) which are produced as end products of fermentation by rumen microbes.

Production of CO<sub>2</sub> is partly from the fermentation and partly as result of formation of volatile fatty acids which expels CO<sub>2</sub> from the carbonate buffer solution.

The gas technique provides a great advantage in that the fermentation takes place in a glass syringe which allows for several measurements to be made on the same sample by measuring the gas volume at different intervals of time. This means that not only the possible extent of fermentation but also the rate of fermentation can be measured. In this respect, the technique is similar to the nylon bag method and the same exponential equation can be used. Thus the gas technique complements the nylon bag technique by measuring end product formation and not substrate disappearance. Results from studies using this approach to predict animal performance (digestibility and intake) showed that the gas technique was slightly inferior to the nylon bag but a much better predictor than other *in vitro* techniques or chemical components of feeds (Blummel and Ørskov, 1993; Khazaal *et al.*, 1993; Dentinho *et al.*, 1994).

Recently, the fact that the gas technique differs from other *in vitro* techniques by measuring evolution of gas as a result of fermentation has been used to adapt it as a biological assay to estimate the level of phenolics-related anti-nutritional factors in feed (Khazaal and Ørskov, 1994; Khazaal *et al.*, 1994). This is achieved by adding phenolic binding agents such as polyvinylpyrrolidone (PVP) or polyethylene glycol (PEG) to the substrate. As a result, the phenolics-related anti-nutritional compounds bind to the phenolic binding agent and their negative effects on fermentation are alleviated.

## **Menke' gas production method**

### *Apparatus*

The apparatus used in the gas production technique may vary slightly from one laboratory to another. At the International Feed Resources Unit (IFRU), the apparatus used is simple. It consists of glass syringes of 100ml capacity which are incubated in a water bath where the temperature is accurately controlled with a water stirring heater. The following procedure is based on the apparatus used in our laboratory.

### *Syringes*

Good quality syringes are essential (syringes of Hliberle Labortechnik, 7901 Lonsee Ettlenschieu, Oberer Seesteig 7, Germany are recommended). The syringes and their pistons should be numbered with a permanent (water-proof) dye starting for example with number 1. A few extra syringes are left as replacement for broken ones.

### *Buffer Solution*

Stocks of the main elements solution (pH 6.8), the buffer solution (pH 8.1), the resazurin solution and the trace element solution can be prepared and stored in dark bottles. The reduction solution must be freshly prepared. The preparation of all solutions is as described on page 9 of the paper by Menke and Steingass (1988). The pH of the buffer mixture solution (i.e. main elements + buffer solution + resazurin solution + trace element + reduction solution) should be about  $7.1 \pm 0.15$ .

### *Preparation of Sample*

The samples are milled through a 1.0 mm screen and their DM content determined. Before weighing the samples, the position of the syringes in each run should be planned. Ideally there should be 3 replicates of a blank and a standard roughage in each run. The triplicates of the blank or the standard roughage should be dispersed among the syringes. Thus one of each is incubated as the first (No 1) and second (No 2) syringes, the second blank and standard will be in the middle, while the third replicate of the blank and standard roughage should be the last 2 syringes (Table 9.2). Samples are normally run in duplicate and a run is usually repeated 3-4 times.

**Table 9.2. Layout of design for measuring gas production.**

Syringe number	Sample	Fresh weight	Level of piston at zero time*	Gas production after		
				3h	6hr	96hr
1	Blank	Empty	about 30			
2	Standard	215±5 mg				
3	Sample A	"	"			
4	Sample B	"	"			
5	Sample C	"	"			
6	"	"	"			
	Sample n					
	Blank	Empty				
	Standard	215±5mg				
	Sample n	"	"			
"	"	"	"			
"	Sample C	"	"			
"	Sample B	"	"			
"	Sample A	"	"			
"	Blank	Empty	"			
n	Standard	215±5mg	"			

\* After injecting rumen liquor:buffer mixture

Weigh about 215±5 mg of air-dry milled (1.0 mm) sample ( gives approximately 200 mg DM if the DM content of the samples is about 90%) into a glass boat. Use an aluminium or metal rod to hold the glass boat containing the sample. Empty the content of the glass boat into the bottom of the glass syringe. Try not to get any particles or dust from the sample onto the high inner side of the syringe since this could affect the movement of the piston.

Lubricate the pistons with a small amount of Vaseline (pure petroleum jelly) to ease the sliding of pistons and prevent gas escape. Push the piston inside the glass syringe gently after opening the clip. Make sure the sample in the syringe is not blown up and that it does not get in touch with the piston.

At IFRU, weighing of samples into the syringes and lubrication with Vaseline are completed the night before the start of the incubation (run). The syringes are then prewarmed in an incubator 40°C overnight before the rumen liquor/buffer solution is injected into the syringe.

If a water bath is used, the heater should be turned on some time before the start of incubation (e.g., the night before).

### *Starting the incubation*

It is important first to calculate roughly how much of the buffer mixture solution and rumen liquor is needed. This will depend on the number of syringes to be incubated. For instance if a total of 35 syringes are to be injected, then at least  $30 \times 35 = 1050$  ml of rumen liquor:buffer solution will be needed. In order to be on the safe side it is better to prepare at least 1200 ml of the mixture and, for that, 800 ml buffer and 400 ml filtered rumen liquor is needed. The 800 ml of the buffer mixture solution is prepared first in a Wolf flask. The content of the flask is heated to  $39^{\circ}\text{C}$  and then transferred to the small water bath. A submerged stream of  $\text{CO}_2$  is pumped into the liquid until it becomes colour-less or very slightly pinkish. Then, lift the stream of  $\text{CO}_2$  to a level above the surface of the liquid. It is important that the stream of  $\text{CO}_2$  is lifted to prevent over-saturation of the buffer mixture with  $\text{CO}_2$ . If this is allowed to happen, more  $\text{CO}_2$  gas will be released as a result of buffering the volatile fatty acids during fermentation and, as a result, the variability between runs will increase. The reduction solution is added minutes before the addition of the rumen liquor.

### *Rumen liquor*

The donor animals could be cattle, sheep or goat but should be receiving a balanced roughage-based diet (at IFRU, 3 rumen cannulated sheep are used and they receive 1200 g of hay and dehydrated grass cubes (2:1) in two equal feeds per day). Before the morning feed, an equal amount of rumen liquor from each of the 3 sheep is pumped into plastic bottles and quickly stored in warmed Thermos flasks and taken to the laboratory. Then, the rumen liquor is stirred and filtered through 2 layers of muslin. The filtered rumen liquor is bubbled with a stream of  $\text{CO}_2$  for 1-2 minutes. This is followed by adding the required amount of filtered rumen liquor ( $\text{pH } 6.3 \pm 0.15$ ) while stirring the buffer solution in the flask. Remember that the proportion of rumen liquor to buffer is 1:2 (the pH of the rumen liquor/buffer mixture should be about  $6.90 \pm 0.1$ ).

### *Inoculation*

Record the zero time (i.e., the time when injection of the rumen liquor:buffer mixture into the syringes is started) of the incubation.

Inject  $30 \pm 1.0$  ml of rumen liquor:buffer mixture into each syringe, followed by drawing most of the air from the syringe. Shake the syringe gently to make sure that all the substrate is mixed with liquid and then take out all remaining air or air bubbles from the syringe. Record the level of the piston (which should be around 30.0 ml) and incubate the syringe in a water bath ( $39 \pm 0.1^\circ\text{C}$ ).

Record the time when you finish filling the syringes with the rumen liquor-buffer mixture. The period of time needed to complete the filling of all syringes with the rumen liquor:buffer mixture should be as short as possible. At IFRU, it takes about 15-20 minutes to complete 54 syringes.

Shake the syringes gently 30 minutes after the start of incubation and then every hour during the first 8-10 hours of incubation. This is important for roughage with low rates of degradability, which tend to float. When gas production is recorded, shake the syringes after taking the reading.

Normally, the time required to inject the rumen liquor-buffer mixture into the syringes is longer than that required to read the volume of gas production during incubation. This difference, particularly if highly fermentable feeds are studied, can lead to an over-estimation of fermentation of this feeds that received the inoculum first compared with those which received the inoculum last. Therefore, when gas production is recorded at any incubation period, it is best that the time during which the readings are made is similar to that taken when the syringes were inoculated with rumen liquor-buffer. For example, if it took about 30 seconds to fill up each syringe with mixture, then you should allow about 30 seconds for reading the gas volume for each syringe.

### *Duration of incubation*

The duration of incubation should be long enough to allow for the complete description of the curve of gas production (i.e., until the curve reaches a plateau, or until the difference in gas production between the last two incubation times is small). At IFRU, 96 hours of incubation is considered to be sufficient in most cases. The accumulating volume of gas is recorded after incubation periods of 3, 6, 12, 24, 48, 72 and 96 hours. If gas production exceeds 60 ml for a sample, take the syringe out of the water bath. Turn the syringe upwards, open the clip and push the

piston to release the gas. The piston could be pushed until it is close or back to the 35 ml position. Record the new level of piston and resume the incubation.

### *Calculation*

Subtract the volume of gas produced from the blanks (average of 3 replicates) from the volume of gas produced from each sample. This will be the observed volume of gas per x amount of fresh sample. Then, knowing the DM content of each sample, the volume of gas per 200 mg DM can be calculated.

Data for gas production are then fitted to the exponential equation :  $p = a + b(1 - e^{-ct})$  (Ørskov and McDonald, 1979); p represents gas production at time t, (a+b) the potential gas production, c the rate of gas production and a, b and c are constants in the exponential equation.

*Note:* It is acceptable to find that replicates of the blank or the standard roughage that were injected first with rumen liquor-buffer mixture produce slightly less gas (1-1.5 ml) compared with the ones that were injected last. It is not very clear why this happens. One possible explanation is that during injection of the rumen liquor-buffer mixture, more particles accumulate at the bottom of the flask as the content of the Wolf flask becomes smaller. Another more likely explanation is that the rumen liquor-buffer mixture becomes increasingly saturated with CO<sub>2</sub> towards the end of inoculating the syringes compared to the start. This is why it is important to place syringes of blank and standard at different positions in each run.

### *Limitations to the technique*

- In order to use the technique reliably, it is essential to be sure of a constant supply of electricity in order to maintain a constant temperature during incubation.
- Like other *in vitro* techniques, it is a closed system in which end products accumulate and can inhibit fermentation or create an environment very dissimilar to the rumen.
- The technique will slightly under-estimate the nutritive value of feeds that are high in protein. This is due to the fact that protein fermentation contributes little to the total volume of gas production.

**Theodorou's gas production technique**

Prepared by: *Mauricio Rosales and Chris Wood, Livestock Section, Natural Resources Institute, Chatham Maritime, Chatham. ME4 4TB. UK*

*Background*

In principle, this technique is similar to the Menke *et al.* (1889) gas production procedure using ground particulate substrates, anaerobic media and rumen fluid inoculum. It differs, however, in that incubations are conducted in gas-tight culture bottles, thus enabling gases to accumulate in the head-space as the fermentation proceeds. A pressure transducer connected to a digital readout volumeter and a gas-tight syringe assembly is then used to measure and release the accumulated gas pressures from the incubated culture bottles. By repeating the "gas-measurements + gas-release" procedure at regular intervals, it is possible to construct gas accumulation profiles for feeds. The rate and extent of fermentation can also be calculated (Theodorou *et al.*, 1994).

The method was developed to get information on the fermentation kinetics of ruminant feeds based on long term end-point fermentations (166 hours). However, shorter fermentations (48 and 72 hours) have been also to evaluate tropical forages and rank them according to their fermentability. The method was developed with a nitrogen-rich (Theodorou) medium but the Menke medium can be used when a nitrogen free medium is needed. The protocol describes how to prepare both media. The technique has also been adapted to the biological evaluation of the effects of phenols on fermentation by adding binding agents such as polyethylene glycol (PEG), polyvinylpyrrolidone (PVP) and polyvinyl-polyppyrrolidone (PVPP) (Rosales, M. and Wood, C., 1994, unpublished data).

*Preparation of the sample (Thursday or earlier)*

Grind substrate to pass through 1 mm dry sieve (if not already ground). Weigh out substrate. Generally use 1 g total substrate, weigh to tolerance of  $\pm 0.0020$  g. Make up stock solutions for medium. Recipes for media are given below. Arrange serum bottles in order placing them on trays for easy handling.

*Preparation of the medium (Friday)*

Make up suitable amount of medium. Stir and gas with CO<sub>2</sub> for about 2 to 3 hours, then add a small volume of reducing agent (about 2 ml per litre buffer; 3 ml for Menke's medium). Continue gassing until the resazurin in the medium is pink. Dispense 90 ml medium into 125 ml serum bottles using pump and gassing with CO<sub>2</sub>. Make 5 to 10 spare bottles for use in preparing the inoculum. Seal with butyl rubber stoppers, but do not crimp. Store at 4°C.

*Place the samples into the bottles (Monday)*

Make up a suitable amount of reducing agent in fume cupboard, keeping it stirred and under an atmosphere of nitrogen. Using a small wide bore funnel transfer the substrates into their bottles and add 4 ml reducing agent. Samples are normally run in triplicate. Remember to add reducing agent to the spare bottles. Keep gassing with CO<sub>2</sub>. Reseal with butyl rubber stoppers and crimp with aluminium caps. Replace in incubator at 4°C and programme it to switch to 39°C at about 2 am.

*Prepare inoculum (Tuesday)*

A minimum of 2, and preferably 3, people are required to inoculate the bottles.

Collect rumen fluid starting at about 8.15 am and keep it warm in a Thermos flask. Filter fluid through 4 layers of course cotton muslin and collect in beaker (with volumes marked) under atmosphere of CO<sub>2</sub>. Keep liquid stirred (not too vigorously). Note approximate volume of filtered liquid. Transfer solids to a blender and add a volume of medium (using the spare bottles prepared earlier) approximately equal to the volume of filtered liquid. Blend for about 30 seconds and filter through muslin into the beaker with filtered liquid to pool with original filtered rumen fluid. Keep stirred and under CO<sub>2</sub>. The inoculum is now ready for use.

*Inoculation of bottles (Tuesday)*

While the inoculum is being prepared, the serum bottles must be adjusted to atmospheric pressure. This is done by using the "taking gas readings" procedure described below, but the gas volumes produced are not normally noted. Bottles are returned to the incubator at 39°C.

Using a 10 ml syringe and 21 gauge 1.5 in (0.8 x 40 mm) needles



(colour code green), 5 ml of inoculum is injected into each bottle. Shake bottles and return to incubator.

Starting at 10 am, the bottles are readjusted to atmospheric pressure, shaken and returned to the incubator. This is taken as the starting point (time = 0) of the experiment.

### *Taking gas readings*

Readings are then normally taken at the following times:

Time	Hrs after start	Day
13.00	3	Tuesday, day 1
16.00	6	
19.00	9	
22.00	12	Wednesday, day 2
02.00	16	
06.00	20	
10.00	24	
14.00	28	
19.00	33	Thursday, day 3
01.00	39	
07.00	45	
14.00	52	
22.00	60	Friday, day 4
08.00	70	
20.00	82	
08.00	94	Saturday, day 5
20.00	106	
08.00	118	Sunday, day 6
08.00	142	Monday, day 7
08.00	166 (end)	Tuesday, day 8

A pressure transducer (Bailey and Mackey Ltd, Birmingham B42 1DE, UK) is used to measure headspace pressure in the bottles. The transducer should have a range of 0 - 25 psi, accuracy of  $0.1 \pm 2\%$ , readings calibrated to read in units of psi. It is connected to a disposable Luer lock 3-way tap allowing a needle (23 gauge 1 in, 0.6 x 25 mm; colour-coded blue) and syringe to be fitted to the other outlets.

Gas pressure is read by removing bottles tray by tray from the incubator, inserting the needle through the butyl rubber stopper into the

headspace above the culture medium. Note pressure. Adjust the pressure to atmospheric by removing gas into the syringe and note volume of gas removed (read from syringe). Take readings for all of the bottles in the tray, shake the bottles, and return them to the incubator.

#### *Determination of dry matter disappearance (DMD)*

At the end of the gas production run, vacuum filter through pre-weighed filter crucibles (Sintaglass, porosity 1 - regraded P160). Wash bottle with water to remove residues and wash residues on the filter. Oven dry overnight at 105°C. then allow to cool in desiccator and weigh. Express DMD as a proportion of the initial dry matter in the substrate.

#### *Theodorou medium*

(otherwise called Basal Medium D by Theodorou)

#### Component solutions

##### 1. Micro-mineral solution (g per 100 ml)

This is made up in 100 ml lots and stored in the refrigerator as a stock solution.

CaCl <sub>2</sub> .2H <sub>2</sub> O	13.2
MnCl <sub>2</sub> .4H <sub>2</sub> O	10.0
CoCl <sub>2</sub> .6H <sub>2</sub> O	1.0
FeCl <sub>3</sub> .6H <sub>2</sub> O	8.0

##### 2. Buffer solution (g per litre)

This is made up in variable quantities and can be stored in a fridge. Calculate how much is required for each run.

NH <sub>4</sub> HCO <sub>3</sub>	4
NaHCO <sub>3</sub>	35

##### 3. Macromineral solution (g per litre)

This is made up in variable quantities and can be stored in the refrigerator. Calculate how much is required for each run. The same volume of buffer and macromineral solution is required in the medium.

Na <sub>2</sub> HPO <sub>4</sub> .12H <sub>2</sub> O	9.45
KH <sub>2</sub> PO <sub>4</sub>	6.20
MgSO <sub>4</sub> .7H <sub>2</sub> O	0.60

## 4. Resazurin solution

Resazurin 0.1g/100 ml water

To make medium: mix the component solutions in the following amounts to make about 900 ml medium. Use same proportions if more buffer is required (which will usually be the case).

1. Microminerals	0.1 ml
2. Buffer	200 ml
3. Macrominerals	200 ml
4. Resazurin	1 ml
5. Distilled water	500 ml

The medium is kept mixed and CO<sub>2</sub> bubbled through it.

## Theodorou reducing agent

Cysteine HCl.1H <sub>2</sub> O	625 mg
Distilled water	95 ml
1M NaOH	4 ml
Sodium sulphide	625 mg

Add ingredients together in fume cupboard and stir under a stream of N<sub>2</sub>.

*Menke style N free media*

## Component solutions

1. Solution A (same as Theodorou Micromineral solution) (g per 100 ml)

This is made up in 100 ml lots and stored in fridge as a stock solution.

CaCl <sub>2</sub> .2H <sub>2</sub> O	13.2
MnCl <sub>2</sub> .4H <sub>2</sub> O	10.0
CoCl <sub>2</sub> .6H <sub>2</sub> O	1.0
FeCl <sub>3</sub> .6H <sub>2</sub> O	8.0

2. Solution B (g per l) Calculate how much is required for each run.

NaHCO <sub>3</sub>	39
--------------------	----

3. Solution C (g per l) Calculate how much is required for each run.

Na <sub>2</sub> HPO <sub>4</sub> (anhydrous)	5.7
KH <sub>2</sub> PO <sub>4</sub>	6.2
MgSO <sub>4</sub> .7H <sub>2</sub> O	0.6

4. Resazurin solution (same as for Theodorou medium) (Resazurin 0.1g/100 ml water)

Medium prepared by mixing:

Solution A	0.1 ml
Solution B	200 ml
Solution C	200 ml
Resazurin	1 ml
Distilled water	400 ml*

\* *Note:* Theodorou medium similar but less concentrated generally as more water is added. The Menke buffer has the composition described by Menke *et al.* (1988).

The medium is gassed with CO<sub>2</sub> and small volume of Menke reducing agent added to reduce it prior to bottling, similar to the treatment of the Theodorou medium.

#### *Menke reducing agent*

Distilled water	95 ml
1M NaOH	4 ml
Sodium sulphide	625 mg

(same as Theodorou reducing agent without cysteine).

Add ingredients together in fume cupboard and stir under a stream of N<sub>2</sub>.

#### *Curve fitting*

A single pool model can be fitted:

$$y = a + b(1 - e^{-ct})$$

excluding data collected over the first 9 hours.

Using STATGRAPHICS, non-linear correlation:

$$\text{PARM}[1] + \text{PARM}[2] * (1 - e^{(-1 \times \text{time} \times \text{PARM}[3])})$$

Parameter vectors: -10, 280, 0.035

### **Estimation of microbial protein supply to ruminants based on urinary excretion of purine derivatives**

*The details of this method were contributed by X.B. Chen, Rowett Research Institute, Scotland*

#### *Background*

Microbial protein formed as a result of rumen fermentation of carbohydrate under anaerobic conditions is the major source of protein for ruminants. On many basal diets derived from tropical feed resources, that are low in nitrogen (e.g., crop residues, sugar cane, molasses and cassava roots), microbial protein is virtually the only source of protein. While this fact has been known for a long time it has been extremely difficult to determine the microbial protein contribution.

The method usually used are based on determinations of microbial markers, such as RNA, DAPA and 35S. These methods involve complicated procedures of measuring digesta flow and require usually the use of animals fitted with post-ruminal cannulae. It is therefore difficult in practice to conduct extensive *in vivo* studies on microbial protein synthesis. The method based on measurement of purine derivatives in urine overcomes the disadvantages of the above methods. It is simple (it requires only total collection of urine) and non-invasive (no surgical preparations are required). It is particularly appropriate as a simple tool to study factors affecting microbial production in the rumen. It has the potential to be further simplified for use under farm conditions.

#### *The principle*

Ruminant feeds usually contain small amounts of purines, most of which undergo extensive degradation in the rumen as a result of microbial fermentation. Absorbed nucleic acid purines are degraded and excreted in the urine as their derivatives: hypoxanthine, xanthine, uric acid and allantoin. The excretion of purine derivatives is directly related with the purine absorption. With knowledge of the purine:protein ratio in microbial biomass, microbial protein absorption can be calculated from the amount of purine absorbed which in turn is estimated from urinary excretion of purine derivatives.

### *Procedure*

Some important experimental details are given as follows:

#### *Urine collection*

It is essential to ensure a complete collection of urine and separation of urine from faeces. To obtain a realistic estimation of daily excretion of purine derivatives, urine collection needs to be made for more than 5 days. This helps to reduce the error due to the 'end-of-collection' variation in urine output of the animal. Collection can also be made as a bulk for the whole period. However, where analytical facilities allow, it is better to make the urine collection daily, to obtain additional information on the variability of the daily measurements. In general, this day-to-day variation is about 10%.

Urine is collected into a container, with an appropriate amount of 10%  $\text{H}_2\text{SO}_4$  so that the final pH of the urine is below 3 to prevent bacterial destruction of the purine derivatives in the urine. Since the purine derivatives concentration in urine is very high and precipitation (particularly of uric acid) can occur during storage, dilution by about 5 times prior to storage will prevent the occurrence of precipitation.

#### *Determination of purine derivatives*

In sheep, all four compounds are present in the urine. The proportions are approximately: allantoin 60-80%, uric acid 30-10% and xanthine plus hypoxanthine 10-5%. the proportion of allantoin increases with the daily excretion of purine derivatives. For this reason, the sum of four compounds, instead of allantoin alone, is used as the parameter to measure microbial protein supply.

Cattle urine contains allantoin and uric acid (allantoin 80-85%; and uric acid 20-15%). Within the same animal, the proportions of allantoin and uric acid are very constant, but there seems to be variation between animals. In dairy cows, allantoin and uric acid are also secreted in milk. The daily amount secreted in milk is equivalent to less than 5% of that excreted in the urine, and purine derivatives concentrations in milk appears to be constant. Correction for the output of purine derivatives *via* milk based on analyses done on several milk samples will be useful.

Methods for the chemical analysis of purine derivatives using various instruments, spectrophotometer, autoanalyser and high performance liquid chromatography (HPLC) are given in Table 9.3.

**Table 9.3. Methods for determination of urine derivatives.**

Spectrophotometer	Autoanalyser	HPLC	Authors
A			Young & Conway, 1942
AU			Fujihara <i>et al.</i> , 1987
U X	A		Pentz, 1969
X	A U X		Chen <i>et al.</i> , 1990
	A		Chen <i>et al.</i> , 1993
	A U X		Balcells <i>et al.</i> , 1992
	A		Diez <i>et al.</i> , 1992
A			Borchers, 1977
U			Fossati <i>et al.</i> , 1980
	A		Lindberg & Jansson, 1989
		A U	Lux <i>et al.</i> , 1992

A Allantoin; U Uric acid; X Xanthine

#### *Calculation of intestinal flow of microbial N from excretion of purine derivatives*

The daily excretion of total purine derivatives (allantoin, uric acid and xanthine plus hypoxanthine for sheep; and allantoin and uric acid for cattle) is calculated and expressed in mmol/day.

Based on experimental results published in the literature on the quantitative relationship between excretion of purine derivatives and purine absorption, the amount of microbial purines absorbed by the animal is estimated. Here it should be noted that different models are used for sheep and cattle, as discussed by Chen *et al.* (1991). Published work on models relating excretion of purine derivatives to purine uptake in sheep: Chen *et al.* (1990a,b), Balcells *et al.* (1991); and in cattle: Verbic *et al.* (1990).

The following factors can be used for the calculation of intestinal flow of microbial N from the microbial purines absorbed.

- Digestibility of microbial purines is assumed to be 0.83. This is taken as the mean digestibility value for microbial nucleic acids based on observations reported in the literature.
- The N content of purines is 70 mgN/mmol

- The ratio of purine-N:total-N in mixed rumen microbes is taken as 11.6:100.

The parameters given above are based on information available so far and need to further defined in the future. For this reason, the results should not be taken as absolute values.

### *Expression of results*

The calculated microbial protein supply is expressed as g microbial N per day and/or as g microbial N per kg digestible organic matter(DOMI). The latter is effectively an expression of the efficiency of microbial protein supply. The efficiency can also be expressed as g microbial N per kg digestible organic matter apparently fermented in the rumen (DOMR) to facilitate comparisons with the reports in the literature. DOMR may be assumed to be 0.65 of the DOMI, based on ARC (1984).

### *Limitation*

- The results are not absolute as stated previously although they show good agreement with those obtained by other procedures. Nevertheless, the method is best used to compare differences in intestinal microbial N flows between treatments in the same experiment.
- In the calculation it is assumed that there is little dietary nucleic acid reaching the small intestine. This could be true with most diets but may not be so when animals are fed with rations containing large quantities of fish meal.
- The calculation of microbial N from purine content assumes that the ratio of purine-N:total-N in mixed microbial populations is constant.
- It has been shown that sheep, cattle and possibly other species differ in their purine metabolism. The implication is that different models should be used for these species to relate excretion of purine derivatives with intestinal flow of microbial protein. So far, most information is available for cattle and sheep and very little for other species.



### **Secondary compounds in tropical trees**

*This section was contributed by Mauricio Rosales, Centro de Investigación en Sistemas Sostenibles de Producción Agropecuaria (CIPAV), Apartado 2019, Cali, Colombia*

The term "secondary compounds" is used to describe a group of chemical constituents in plants thought not to be involved in the biochemical processes of plant growth and reproduction (Palmer *et al.*, 1990). These secondary metabolites are thought to have a defensive role that ensures survival of the plant (Coley *et al.*, 1985), by protecting against insect predation or by restricting grazing by herbivores (Swain, 1979). These secondary compounds have been implicated in limiting the utilization of many tropical feed resources, particularly trees and shrubs. They can inhibit digestion, have toxic effects, inhibit some enzymes and/or metabolic processes, or act as precursors of anti-nutritional compounds (Palo, 1987).

As summarized by Barry and Blaney (1987), secondary compounds can be toxic to animals or cause reduction in their productivity by reducing feed intake. These plant constituents do not affect all herbivores equally; there are examples of plants being toxic for monogastric species but not for ruminants, because the toxin is rendered harmless by the rumen bacteria (Dobson, 1959).

There are more than 1200 classes of secondary compounds. These include among others, polyphenols, cyanogenetic glycosides, alkaloids, saponins, steroids, toxic proteins and amino acids, non-protein amino acids, phytohemagglutinins, triterpenes and oxalic acid (Kumar, 1992; Liener, 1980).

#### *Tannins*

Discussion here will be restricted to tannins which are the most common secondary compounds in tropical fodder trees. Vegetable tannins are water soluble polyphenolic compounds having relative molecular mass between 500 and 3000 (Haslam, 1981). Besides giving the natural, usual phenol reactions, they have some special properties such as the capacity to bind strongly with proteins, polysaccharides, nucleic acids, steroids, alkaloids and saponins (Mueller-Harvey and McAllan, 1992; Haslam,

1981). The mechanism of vegetable tannage is generally accepted to be the formation of a hydrogen-bonded network between hydroxyl groups of vegetable tannins and relevant groups in collagen, and hydrophobic interactions between vegetable tannins and certain regions or groups of the collagen polymer (Spencer *et al.*, 1988).

Traditionally, tannins have been divided into two groups: the condensed and hydrolyzable tannins. However, a new group, the complex tannins has been proposed (Tang *et al.*, 1992). It is generally thought that condensed tannins are less harmful than hydrolyzable tannins, although both have the capacity to bind protein.

#### *Nutritional effects of tannins*

Studies of the effects of tannins in animal nutrition have involved a wide range of plants and have covered a wide variety of animal species. In the vast majority of cases, there has been little or no characterization of tannins present in the feedstuffs used (Mueller-Harvey *et al.*, 1987). In general, tannins cause growth depression and an adverse effect on protein and dry matter digestibility (Liener, 1980). They can also produce liver necrosis, act as a pectinase inhibitor and as carcinogenic agents (NAS, 1973).

Tannins are known to impart an astringent or bitter taste and, at a certain level in the diet, may therefore reduce the palatability. However the effects of tannin may also be quite negligible or indeed they may even enhance intake (Mueller-Harvey and McAllan, 1992).

Levels between 0.2 and 2% (DM basis) of tannins have been shown to depress dry matter, protein and amino acid digestion, reduce energy utilization and growth and lead to poorer feed efficiency ratios in poultry. Leg abnormalities have been found in chicks fed sorghum grain of high tannin content. Histopathological effects in chicks include decreases in blood haemoglobin, red and white cell counts and necrosis of the kidney and liver. Decreases in egg production and yolk discolouration have also been reported (Mueller-Harvey and McAllan, 1992).

In pigs, a reduction in dry matter digestibility has been reported. Physiological abnormalities resulting from continuous ingestion of free gossypol by young pigs include anorexia, dyspnoea, hydrothorax and

oedema of lungs, hepatic degeneration and dilation of the heart. In general, feeding with high tannin diets results in poor performance, particularly on feed conversion efficiency (Liener, 1980).

The effect of tannins in ruminant feeding is not consistent and there are reports of possible harmful and beneficial effects (Zelter *et al.*, 1990; Barry and Duncan, 1984). The two types of tannins differ in their nutritional and toxic effects. The condensed tannins have a more profound digestibility-reducing effect than hydrolyzable tannins, whereas the latter may cause varied toxic manifestations due to hydrolysis in the rumen.

Rumen microbes have been shown to degrade flavonoids. Strains of *Butyrovibrio* and *Peptostreptococcus* are prominent in the cleavage of heterocyclic rings. However, there are little or no data available on the degradation of tannins by the rumen microflora (Deschamps *et al.*, 1983; Field and Lettinga, 1992). Since rumen micro-organisms may modify or metabolize ingested tannins, the extensive adaptation of rumen microflora to different plant constituents could be of particular importance in reducing the potential toxicity of ingested tannins. These ingested tannins may act in the rumen in a number of ways such as:

- Affect the species and composition of the microflora.
- Complex with and inhibit extracellular enzymes produced by the microflora.
- Complex and render unavailable dietary nutrients.
- They (or metabolic products) may be absorbed from the rumen and prove toxic at the tissue level (Mueller-Harvey *et al.*, 1992).

Evidence is increasing that tannins can have some benefits. Tannins have been found to have bloat-safeguarding properties. It has been suggested that tannins inhibit the production of stable foam in the rumen helping to control bloat (Lees, 1992). Low concentrations (2% in dry matter) of tannins from *Lotus* have been shown to reduce the carcass fatness in growing lambs, whereas with high tannin diets increased levels of growth hormone were found in sheep blood (Barry and Manley, 1986). Dietary condensed tannins from *Lotus pendiculatus* (2-3% in DM) have been shown to impart beneficial effects because they reduce the protein degradation in the rumen by the formation of a protein-tannin complex (Barry and Blaney, 1987).

### *Tannins and By-pass Protein*

Protein that is slowly degradable in the rumen may provide amino acids and peptides for microbial growth in addition to providing by-pass protein. Tannins are known to protect dietary protein against microbial attack in the rumen. Thus if a freshly harvested tropical legume given as a supplement is to provide by-pass protein then it should be selected for a relative high content of tannins, even though this may depress fibre digestibility. The benefits of including by-pass protein in the diet have been widely documented (Preston and Leng, 1987).

The tannin-protein complexes have maximum stability in the pH range 4-7. Above and below this pH range the complex is readily dissociated. In this way the tannin-protein complex, after escaping from the rumen fermentation (about pH 5-7), would be digested readily by the enzymes in the gastric (about pH 2.5) and pancreatic (about pH 8-9) secretions (Palo, 1987).

### *Chemical determination of secondary compounds*

The traditional chemical analyses of feeds do not take account of the secondary compounds or their anti-nutritive effects. But the key to assessing the nutritive value of tree leaves lies in the ability to estimate the presence and effects of these compounds.

There is a wide range of analytical techniques that have been developed to analyze particular plant secondary compounds. High Performance Liquid Chromatography (HPLC) is perhaps the most sophisticated tool for the rapid screening of plant materials. It is however comparatively expensive and not readily accessible to research scientists in developing countries. HPLC can characterize the secondary compounds profile of the plant, but gives no estimate of action on the animal (Gill *et al.*, 1992).

The main difficulty is that there is a wide variety of such compounds and each requires a different analytical method. It is not practical to consider analyzing each species for each compound. The diversity in chemical structure is extremely problematic when choosing an appropriate method of analysis. However, the presence of antinutritional factors can be determined qualitatively using the preliminary phytochemical tests described below.

### Phytochemical preliminary tests

The presence of anti-nutritional factors can be determined qualitatively according to the methods described by Larrahondo (1985) and Rosales *et al.* (1989). An extract is prepared and colour changes observed following addition of various reagents, giving an indication of the presence of phenols, steroids, alkaloids and saponins.

#### *Preparation and extraction of the leaf material*

Weigh 10 g of fresh leaves, place them in a mortar and grind them after the addition of 30 ml of ether and 30 ml of a 9:1 methanol-water solution. Filter the resulting solution, place it in a separating funnel and leave it to stand until two separate layers can be identified. The lower layer is the methanol-water polar fraction, the top non-polar fraction being formed with ether. Both phases are used in subsequent analysis.

#### *Saponins*

9 ml of water are added to 1 ml of the methanol fraction and then filtered. 1 ml of this solution is shaken in a small test tube for 30 seconds. After 15 minutes, the height of foam in the tube is measured, giving an indication of the levels of saponins in the forage:

Height of foam:

- 5 mm or less = Negative.
- 5 - 9 mm = Low content of saponins.
- 10 - 14mm = Medium content of saponins.
- 15 mm or more = Forage high in saponins.

#### *Phenols*

Three drops of the methanolic fraction are placed in a five division ceramic test plate. Drops of distilled water are added to each division to give a yellow colour. One drop of  $\text{FeCl}_3$  is added to the solution in the first division, two drops in the second, and so on. The last division is left as a control. Changes in colour indicate the presence of phenolic compounds as follows:

- No change = No phenols or tannins
- Dark Blue = Water soluble tannins or phenols.
- Dark Green = Flavonoids or condensed tannins.

*Steroids (Lieberman-Buchard)*

1 ml of the non polar-fraction is evaporated in a basin and 4 drops of chloroform added. One drop of the resulting solution is placed in each division of the test plate plus 2 drops of acetic anhydride and one of concentrated sulphuric acid. Changes in colour indicate the presence of steroids as follows:

- Blue or Green = Steroids.  
 Red, Pink or purple = Triterpenoids  
 Light Yellow = Saturated Steroids or triterpenoids.

*Alkaloids (Dragendorff)*

4 drops of ammonia (NH<sub>4</sub>OH) are added to 3 ml of the methanolic fraction. The sample is reduced by evaporation in order to concentrate the compound of interest. Then 3 drops of acetic acid and one of distilled water are added. The solution is evaporated again and drops of the final residue are placed on a filter paper. These drops are covered with drops of the Dragendorff reagent, a colour change to red or pink indicates the presence of alkaloids.

An example of the results of a preliminary test is shown in Table 9.4

**Table 9.4. Results of qualitative contents of antinutritional factors in the some forage trees Source: Rosales *et al.*, 1989).**

Tree species	Phenols	Steroids	Alkaloids	Saponins
<i>Trichanthera gigantea</i>	+	++	-	+
<i>Gliricidia sepium</i>	+	+	-	++
<i>Inga spectabilis</i>	+++	++	-	++

*Chemical determination of tannins*

The chemical diversity of tannins makes their analysis difficult. Several methods have been developed, especially to measure chemical groups or structures. Of these the most widely used are the Folin or Prussian blue method for the determination of total phenols (see Price and Butler,

1977) and the acid-butanol method for the determination of condensed tannins (see Porter *et al.*, 1986). Hagerman and Butler (1989) have made a critical review of analytical techniques.

An alternative approach is to assess the biological effect of the tannins, for example in relation to their capacity to precipitate proteins. Several methods for assays of this type have been developed, the radial diffusion assay of Hagerman (1987) being the most recent and probably the easiest to perform. A modification of this method is described below. This method measures condensed and hydrolyzable tannins, but is unable to distinguish between them.

### **Radial Diffusion Method for Phenolics**

*Adapted by C Wood (Natural Resources Institute, Chatham, ME4 4TB, Kent, UK) from the method of Hagerman (1987)*

#### *Equipment*

1. 8.5cm petri dishes
2. Water bath at 45-50°C

#### *Reagents*

1. Buffer A  
Dissolve 10.6mg of ascorbic acid in a small amount of distilled water. Add 2.9ml of glacial acetic acid and make up to just under 1 litre with distilled water. Adjust to pH 5 using NaOH pellets (about 14 are required). Make up to 1 litre with distilled water.
2. Agarose (Type 1, Sigma)
3. Bovine haemoglobin (Sigma M2500)
4. 70% aqueous acetone  
350ml acetone made up to 500ml with distilled water

#### *Procedure*

The assay is normally conducted in duplicate on different plates. Samples are usually extracted in duplicate. Therefore each sample requires 2 wells on each of 2 plates.

*Preparation of agarose plates*

1. Prepare a 1% (w/v) solution of agarose by suspending the agarose in a small volume of cold buffer A and add to boiling buffer whilst stirring.
2. When all the agarose is dissolved transfer to a waterbath at 45-50°C and allow to cool.
3. Add 0.1% haemoglobin whilst stirring with a glass rod until fully dissolved.
4. Rapidly pipette 9.5ml of the warm agarose/haemoglobin solution into a petri dish using an open-ended pipette.
5. Allow to stand on a flat surface to cool, and refrigerate.
6. Do not store for more than a week before using.
7. Mark the underside of the dish with a line to mark the origin (so that the numbering sequence of wells can be determined) and dots to mark where the well are to be located. Wells must be at least 15mm apart and a similar distance from the sides. Generally 8 wells are cut using a 4mm cork borer and the gel core removed.

*Preparation of the leaf extracts*

1. Accurately weigh approximately 500mg ( $\pm 10$ mg) of dried sample (ground to pass a 1mm screen) into a 10ml glass beaker.
2. Add 5ml of 70% aqueous acetone and homogenize for 1 min using an ultraturrex at medium power.
3. Transfer to a 15ml coned centrifuge tube and centrifuge at 2000rpm for 10 mins.

*Plating out of extract*

1. Add 15  $\mu$ l of the extract to a well.
2. Apply the extracts in a clockwise sequence around the plate. Duplicate extracts are plated out in duplicate onto two different plates, thus giving four plates per sample.
3. When fully loaded, the plates are left until the extract penetrates the gel.
4. Seal the petri dish with parafilm and incubate at 30°C for 4-5 days.
5. Measure the diameter of the rings of precipitated protein with a vernier scale to the nearest 0.05 mm and then measure again at a 90° angle to the first measurement.



*Calculation*

Duplicate a

$$\text{Average diameter (da)} = \frac{(\text{daA1} + \text{daA2} + \text{daB1} + \text{daB2})}{4}$$

$$\text{Average ring area (a)} = \text{da}^2 - 16$$

$$\text{Radial diffusion RD/g} = \frac{\text{area (a)} \times 3.33}{\text{sample wt. a (g)}}$$

Duplicate b

$$\text{Average diameter (db)} = \frac{(\text{dbA1} + \text{dbA2} + \text{dbB1} + \text{dbB2})}{4}$$

$$\text{Average ring area (b)} = \text{db}^2 - 16$$

$$\text{Radial diffusion RD/g} = \frac{\text{area (b)} \times 3.33}{\text{sample wt. b (g)}}$$

$$\text{RD/g (DM basis)} = \frac{100}{\% \text{DM}} \cdot \frac{[\text{RD/g (a)} + \text{RD/g (b)}]}{2}$$

However, to suggest that protein precipitation assays are the sole recommended technique is perhaps an over-simplification. Low molecular weight phenolic compounds are potentially very toxic to animals and it is not certain whether they will precipitate proteins. What is also uncertain is whether low molecular weight phenolics are extensively degraded in the rumen or are the symptoms of toxicity caused by phenolics that themselves are the product of hydrolysis or oxidation of other larger phenolics or tannins.

The gas production methods can also be used to assess the effects of the secondary compounds on the fermentation.

Given the lack of knowledge on the effects of specific tannins, the best approach, at least in the short-term, is to subject samples of fodder trees to a number of methods for analyzing tannins and to combine these data with records of the animal production responses to these species (Gill *et al.* 1992).

## Chapter 10

## Animal feeding trials

*This chapter relates to the design of feeding trials which aim to adapt technologies for use under smallholder farming conditions. In general, such trials will be done on the farms themselves with close participation of the farmers in the planning, execution and evaluation of the interventions. Certain interventions will have finite objectives concerned with responses of a certain species or element of the farming practice to variations in inputs. In all cases the activity should be planned to take account of the overall farming system and the impact that the intervention will have on that system.*

### INTRODUCTION

As far as possible, animal feeding trials should be done on farms since the objectives usually are to test interventions in a situation where conditions of management and resource availability are typical of the real-life farmer situation. The farm and the farmers serve as a forum for discussions of practical problems and provide the appropriate setting for participatory adaptation of technologies. By contrast, experiments at the station will have as their aim the study of new feed resources (e.g., with the nylon bag method of assessing rumen degradation potential; the chick biological test to rate protein- rich leaves for monogastric animals) and under-exploited animal species (e.g., the small non-ruminant herbivores).

### EXPERIMENTS ON FARMS

There are four main activities that on-farm work facilitates:

- Economic evaluation of an intervention (e.g., use of molasses-urea blocks for cattle or of urea treatment of straw).
- Biological (and economic) assessment of a nutritional manipulation (e.g., defining a response curve for a given nutritional input as in Figure 5.11).

- Demonstration of appropriate technologies (e.g., biodigesters, recycling manure with earth worms and water plants, agroforestry systems).
- Establishing a forum for discussion, for planning joint participatory activities and as an interface between farmers and scientists

Validation of technologies can be done on any farm scale. The individual farm is the replicate and it is usually relatively easy to have from 8 to 12 farms in such a trial. In Chapter 11, there is an example taken from Vietnam of this kind of economic assessment.

### **Experiments on smallholder farms**

On smallholder farms it is rarely convenient to have more than one treatment. Moreover, the objective is nearly always to assess the economic and social impact of a particular intervention. Smallholder farmers are more concerned with risk and the overall impact of the intervention on their activities in the farming system than in a simple biological response. The experiences in Vietnam with introduction of low-cost plastic biodigesters is a good illustration of this type of reaction (Bui Xuan An *et al.*, 1994). The comments of the farmers (almost invariably the women) were:

- the work is easier because I do not have to look for firewood or spend time tending the fire,
- my kitchen is cleaner and so are the pots and pans, and
- it is very easy to boil water for the tea in the early morning.

For these farmers, the biological efficiency of the biodigester was not an issue. Later, they would come to appreciate that the by-product of the biodigester (the effluent) would be better than the fresh manure for growing crops and fish. But their first concern was the impact of the biodigester on their everyday activities.

### **The role of the larger farm**

It is often argued that the larger farm should be ignored as being unrepresentative of the target group - the poorest farmers. Yet the large farm with a helpful owner or manager can be an asset and a means of

helping the poorer ones. Such farms are particularly appropriate for carrying out the second type of experiment (i.e., response function). It is also not too difficult to identify farmers in this category. Often they will be commercial farms employing managers who are themselves agricultural graduates and therefore with the training that facilitates the more precise execution of the intervention and the daily recording that may be necessary. In the CIPAV programme in Colombia, there are several such farms that perform a most valuable function by participating in joint research activities. They are part of an informal organization of producers that meet frequently as a group with CIPAV researchers to discuss joint problems and new possibilities. Several of the advances in the use of tropical feed resources, reported in this manual, have been developed in these collaborative activities.

Certain types of experiments are very suitable for carrying out on these larger farms. Thus the evaluation of the effects of supplements on milk production (e.g., molasses-urea blocks, tree foliages) can be done relatively easily with good statistical control, using analysis of covariance to correct for animal differences (see Chapter 8 and Table 6.3). In this case adequate replication can be obtained on the farm if the herd is of over 30 cows. The use of covariance and blocking of animals by calving date makes it possible to incorporate cows in varying stages of lactation in the trial.

## **ON-STATION EXPERIMENTS**

### **The general approach**

If investment is to be made in experimental facilities then, in general, it is best these are in the form of individual pens. For a given investment in capital, labour and operational costs, more data can be generated from animals in individual pens than in groups. Groups of animals more closely represent the situation on farms. But this should not be attempted in on-station work, which can never reproduce conditions on farms, nor should this be the objective. On-farm activities are proposed for this very purpose.

**Facilities that are renewable**

In the tropics, protection is needed mainly against the sun and rain. Wind speeds are only excessive in the vicinity of a cyclone, and it is pointless to build structures capable of withstanding events that may never occur. Better to aim for structures that can be recycled and rebuilt using local materials. Bamboo produces renewable materials that can be used to make almost all the structural components needed in a building for all classes of applied animal experiments. Roofs should be made of palm leaves as this produces a structure with excellent thermal insulation characteristics. Only in the case of pigs will concrete be required for the floor. For all animal, pen divisions are easily and conveniently made from bamboo.

The important issue is that the construction material, as much as possible, should be recyclable either for fuel or as compost.

**Grow what is needed and recycle the excreta**

Provided it is understood from the outset that on-station research is mainly a response to, and occasionally a prelude to on-farm work, then decisions can be taken which will reduce considerably the cost of the experimental facilities. At the outset, the station must possess sufficient land to be able to grow the crops that will produce the feed resources most likely to be investigated, i.e., those being recommended for use by farmers. All too often we see heavy investment in laboratories and animal houses but with no land either to grow the feed or to recycle the animal excreta. There are many examples of such reductionist and inappropriate planning at the level of both international and national research centres.

Research stations, in some instances, can perform a valuable role in creating interest and demonstrating confidence in technologies, which may have little application in an era of cheap fossil fuel, but which almost certainly will play an increasing role as the pressure increases to adopt more sustainable ways of using resources.

For instance, it will mostly be appropriate for smallholder farmers to use animal traction rather than mechanical power. The role of draft animals will be enhanced if they are multi-purpose - producing milk and meat as well as power. In this case it is very important that this strategy is demonstrated on the research station. There are too many examples at

research stations in developing countries of mechanical "graveyards" littered with broken tractors and implements.

Research on biodigesters and gasification technology is another area where the research station can set an example for the future.

### **Animal species**

It is not necessary to have facilities on the station to do research with all the target animals. The farming system will be developed on the smallholder farms -- not at the station. Thus it is rarely justified to have milking cows. It is much easier, and more can be done with a given level of funding, when goats are the experimental animals. For example, slatted floors for goats can be made from strips of bamboo. For cattle concrete slabs would be needed. Similarly, sheep are more appropriate than cattle for feed intake and growth studies.

The issue is not whether research findings with sheep or goats can be applied to cattle or buffaloes. The work with the sheep and goats should be directed towards establishing the principles of digestion and metabolism and likely trends in animal response to inputs. The final joint biological and economic evaluation must always be done on farms.

Thus, goats can be used to establish likely responses in milk yield to a range of tree foliage. But the final description of the response curve to one particular tree foliage will be done on a farm where the ecosystem favours growth of that particular tree. The station can grow small plots of a range of trees; the farm will want to concentrate on what is most suitable for the area in which it is situated.

Research stations can play a useful role in introducing under-exploited livestock species (e.g., earthworms, snails and insects), studying their biology and ecology and thus creating interest in their commercial use (Cardozo, 1993).

### **Facilities for research with draft animals**

Most on-station research in tropical developing should be done with two aims always in mind: of doing relevant research at lowest cost. Research on draft animals can be very expensive because of the difficulties of measuring work output. The approach to this issue tends to emphasize sophisticated means of measurement of work output, rather than identify

work activities which might be both useful and easy to measure.

A frequent form of draft animal work in developing countries is the grinding of sugar cane to make 'panela' or 'gur'. Earlier work in Bangladesh (Miah and Sarkar, 1990), subsequently confirmed in Colombia (Thu *et al.*, 1994), showed that the rate of grinding the sugar cane was highly correlated with the work output of the animal (Figure 10.1). Setting up the facilities for a sugar cane crusher and employing it for research on draft animals has many advantages. The work force is easily measured; the output of the work is useful (the cane juice can be used in experiments with pigs); it is easy to train the animals; and the work is done in relative comfort (as the crusher is easily situated under some form of roof or shade).

**Figure 10.1. Relationship between rate of crushing of sugar cane and work force exerted by the animal (Pairs of buffaloes and cattle) (Source: Miah and Sarkar, 1990).**

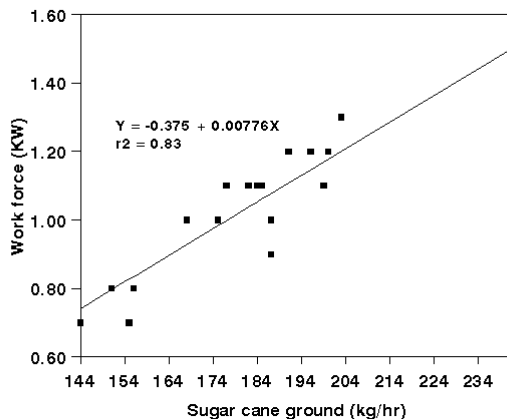

**Design of individual pens**

The first requirement is for pens usually for individual animals, or for small groups in the case of pigs and poultry. The pens can be simple, but, they must facilitate adequate care of the animals, especially feeding and cleaning. Floors which are partially slatted, allowing faeces and urine to fall through into a pit below, are more expensive but the investment is justified in the improved environment for the animals (they are always dry and clean) and elimination of unpleasant tasks for the attendants. The feed hoppers should be designed to avoid spillage and to facilitate the collection of residues. Clean water should always be available.

Pens should be in multiples of four and the minimum needed is 16 units. This gives flexibility for feeding trials with up to four treatments in factorial and latin square arrangements. Animals with rumen fistulae must be held individually; the walls of their pens may need to be solid to prevent them damaging the fistula.

Pen construction in tropical regions can be much simpler and cheaper than in temperate countries where avoidance of stress from cold and wind requires more permanent structures equipped with insulation and often heating.

Feed troughs should be constructed carefully, especially for ruminants that will be fed bulky forages. The aim is to minimize spillage and make it difficult for the animal to pull the feed out into the pen.

Appropriate designs of pens and feed troughs are shown in Figures 10.2 to 10.9.

**Other facilities**

Accurate balances are essential both for weighing animals and feeds. Spring balances should generally be avoided and simple scales which use weights hung from an arm are to be preferred. For cattle it is desirable to be able to weigh by intervals of 500 g and for sheep 200 g. Feed scales should weigh to 100 g.



Figure 10.2. Plans of experimental pens for carrying out feeding trials with cattle. The building is 19.0 m x 7.0 m for 16 pens.

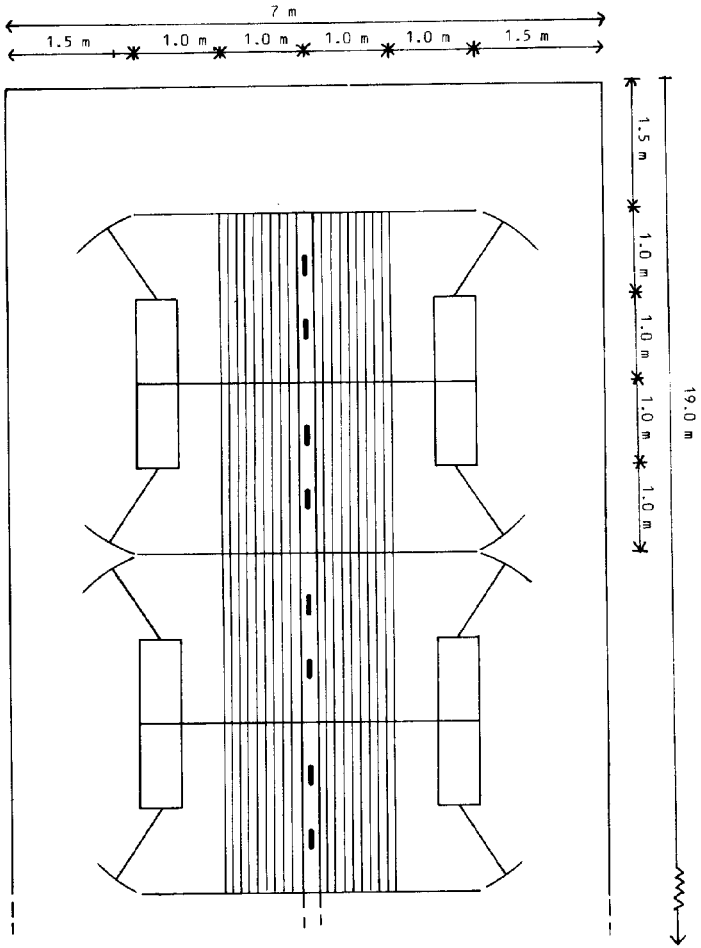

Figure 10.3. Dimensions of cattle slats (in mm).

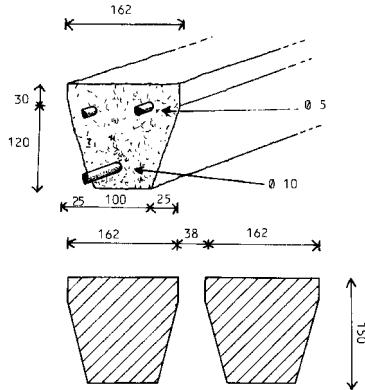
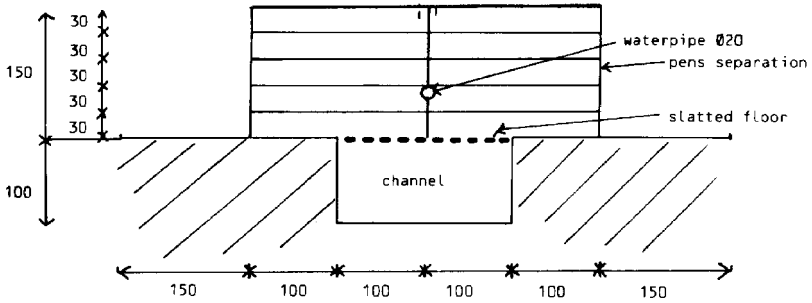
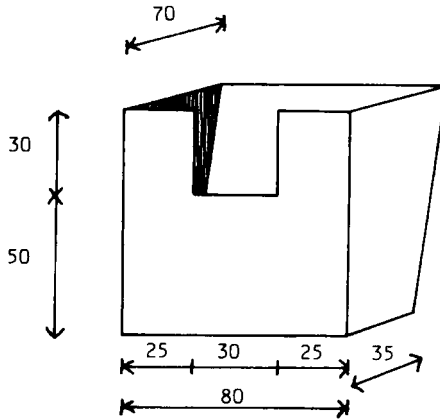

Figure 10.4. Cross-section of cattle pens (in cm).



**Figure 10.5. Dimensions of feed trough for cattle (in cm).**



**Figure 10.6. Plans of experimental pens for carrying out feeding trials with sheep and goats (in cm).**

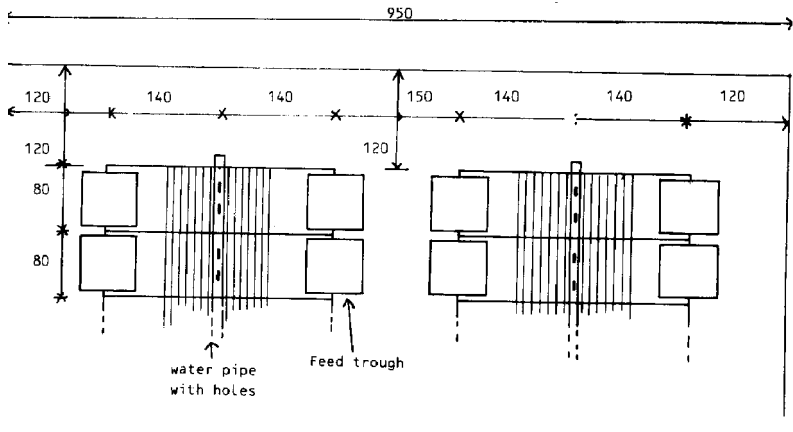

Figure 10.7. Cross-section of experimental pens for sheep and goats (in cm). An elevated floor with the slats made from wood may be a better arrangement.

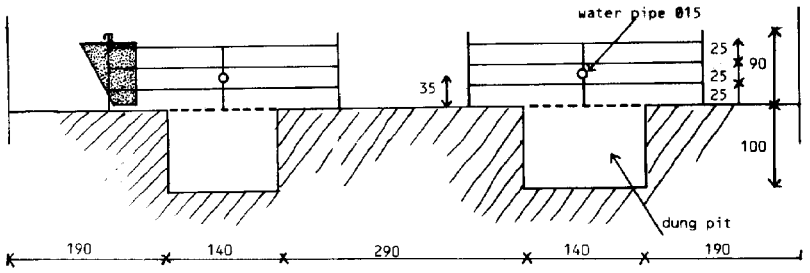

Figure 10.8. Dimensions for slats for sheep and goat pens (in cm).

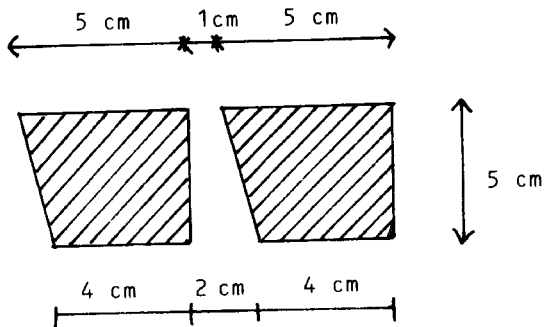
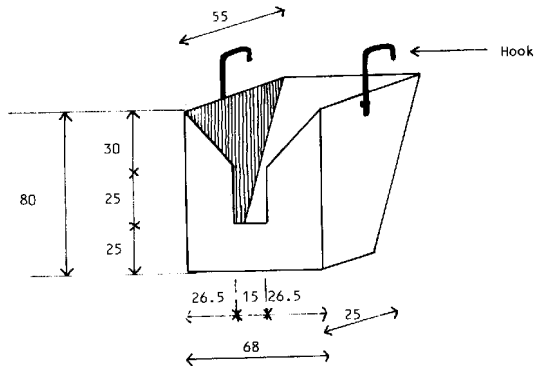

Figure 10.9. Dimensions of feed troughs for sheep (in cm).



## RECORDING

The first item of essential equipment is a notebook computer. These are now relatively inexpensive and available locally in most developing countries. Portability is necessary in order to work on farms. Adapters that permit power to be drawn from the battery of a vehicle, or from a solar panel, provide security for continuous working under most circumstances. Data should be entered in a spreadsheet in a form that will facilitate subsequent analysis and presentation (Chapter 8).

An important ancillary role of the portable computer is that it enables the researcher to demonstrate to the farmer the results obtained on that day on her/his farm. In this way, the farmer feels intimately involved in the research and will be much more likely to collaborate in future activities.

## Chapter 11

# On-farm research: a discussion of some practical examples and procedures

*This chapter was contributed by Frands Dolberg, University of Aarhus, Denmark. Examples are given of studies which in most cases have been conducted within the framework of development projects and they do therefore illustrate on-farm research with a development perspective, i.e., the knowledge gained has been deemed important for better project implementation. Some of the concepts that apply in this kind of research were discussed in Chapter 10.*

## INTRODUCTION

The present chapter of the handbook dealing with on-farm research can be written with much more confidence than was the case for the first edition (Preston, 1986) for the simple reason that there is much more experience to draw from. There is also evidence that technologies beginning to find uptake among small farmers in developing countries and featuring more prominently on research agendas - such as "by-pass" protein (Preston and Leng, 1987) and surplus fibrous crop residue feeding (Owen, 1994) - in fact are old farmer practices to which recent work has lent a scientific understanding. The sucking calf is common across the tropics and the practice has some scientific merit as will be discussed below.

The reader should also consult sources such as Amir and Knipscheer (1989) and Daniels *et al.* (1993), which contain detailed guidelines for on-farm research and examples of routine data collection. On-farm studies have served several objectives at one time like monitoring and evaluation, and not exclusively research (Rangnekar, 1994).

## **ON-FARM RESEARCH**

On-farm research in its model form involves several discreet steps:

- Selection of target areas and farmers, description of their production systems and identification of constraints or opportunities.
- Formulation of research project, i.e., an intervention to overcome the constraints or exploit the opportunities.
- Conduct of the research.
- Provided the research led to positive results, recommendations have to be worked out and training conducted of farmers and extension workers.
- Evaluation of impact of the recommendations, which may lead to identification of new research problems.

However, as these steps are described in the sources cited above, the chapter will be organized so as to illustrate:

- How to set up programmes for integrated base line data collection and technology transfer on small farms and the associated problems of establishing agreement with farmers and the community.
- Measurements to make and how.
- Recording and interpretation.

## **BASELINE DATA**

### **Age-specific mortality in calves**

In order to design appropriate interventions it is important to know the weak points in a traditional production system. Data on age-specific calf mortality from six villages in Bangladesh will be used as an illustration (Figure 11.1).

In work reported by Hermans *et al.* (1989), mortality was estimated in the age intervals birth to 3 months, 3 to 12 months and above 1 year. It was found that mortality for calves above 1 year was consistently the lowest in all six villages with a range of from 1.1 to 4.1%. Among the new-born to 3 months old calves it was high in one village at 15.7%, but was reported to be zero in two villages and only in one village was the mortality rate marginally (6.0 against 5.2%) higher among the very young calves compared to the 3-12 months old, the age group where the highest mortality rate was found.

**Figure 11.1. Calf mortality according to age in villages in Bangladesh (Source: Hermans *et al.*1989).**

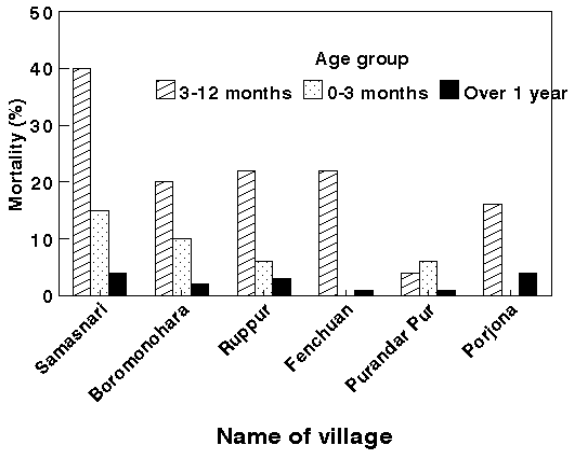

Perhaps this is a somewhat surprising observation as established knowledge would hold that the youngest animals were the most delicate and the highest mortality should be expected in this age group. However, the smallholder, suckling system may represent a different case of relatively well nourished young calves, while the 3 - 12 months old calves encounter nutritional problems (Figure 11.2), an aspect of calf rearing which ought to be researched in many more countries to understand to what extent it can be generalized.

### Collection of the data

The problem with collection of mortality data is to be available on the farm when the death occurs to avoid problems of farmer recall. To overcome this problem, the data were collected by the Bangladesh Cattle Development Project, but analyzed and interpreted by staff of the Dutch Centre for World Food Studies. As the Cattle Development Project had a veterinary service in regular contact with farmers in the area, data collection gained in reliability as the veterinary field workers knew the farmers and their animals and were aware of the prevailing diseases. The problem was to have the data analyzed and a solution was only found



some years after the project was closed and staff involved in the original data collection established contact with the Dutch team.

**Figure 11.2. Calf mortality according to age in villages in Bangladesh (Source: Hermans *et al.* 1989).**

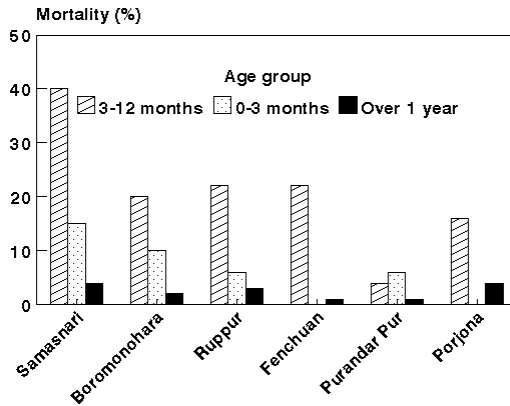

Obviously, the lesson is that a working relationship between a development project, with a good opportunity to collect useful data due to frequency of village visits and trust developed with farmers, on the one side, and an Institute having the ability to analyze such data on the other, should be established from the outset. But such a statement misses reality. In many situations interest, competence and money are not synchronized (Chambers, 1983) and the example illustrates that there can be a fair degree of coincidence associated with generation of interesting data.

## **COMPARING FARMER PRACTICES WITH INTERVENTION**

### **Effect of supplementing suckling calves in a traditional system**

The insights gained in Bangladesh suggested that calves reared in a traditional smallholder system begin to encounter problems around 3 month of age. In the following example from China (Gu *et al.*, 1993), it

was assumed:

- That nutrition was a major difficulty.
- That low mortality in the early period of the calf's life was due to the merits of the traditional suckling system (see Table 11.1).
- And perhaps also - but this has not been studied - the very low number of calves per household, which may minimize contagious disease risk for certain diseases.

In the control group (C) no intervention was made, but the growth pattern of calves in the traditional system was described. The experimental treatments were:

A: A supplement of cottonseed cake *ad libitum*.

B: Cottonseed cake *ad libitum* and ammoniated wheat straw *ad libitum*.

### Organization of the trial

Getting a negative control often represent a special problem as farmers prefer the treatments producing better animal performance and income.

However, there are various ways of settling this issue with farmers. In this case a large UNDO/FAO sponsored feeding trial involving 1027 animals from 312 farms in 12 villages of Henan and Hebei Provinces had been undertaken with the same farmers. This had established a sense of goodwill and farmers could be identified, who were prepared to accept the negative control. The project provided the experimental inputs free (cottonseed cake and urea) and in return the farmers accepted the interruptions caused by fortnightly weighing and frequent visits by officers, responsible for the trial. The results are reported in Figure 11.2.

Growth rates were very good for all three groups during the first month at 850 - 950 g/day, probably as a consequence of the suckling system. However, at 1.5 months, the calves in the control group apparently encountered a nutritional constraint, as growth rate fell to 533 g/day, while it remained high around 900 g/day in both experimental groups.

The growth rates in the control group fell after the first month and remained consistently lower throughout the rest of the six months experimental period. The calves on a supplement of cottonseed cake maintained their high growth rate throughout, although growth rates were reduced slightly after 3 months from above 800 to 700 g/day. In contrast, the calves in the third group, receiving both cottonseed cake and

ammoniated wheat straw, maintained a growth rate above 800 g/day.

At six months, the average calf weight was 136, 166 and 174 kg in the control and two experimental groups respectively. But more importantly, the growth rate at six months of age was 449, 700 and 830 g/day respectively.

The explanation for the very satisfactory performance of the calves in the experimental groups A, and especially B, is likely to be that the suckled milk provided very efficient by-pass nutrients (Preston and Leng, 1987). Thus, simple interventions like a protein supplement and roughage of only medium quality (ammoniated wheat straw) had a very positive effect.

### **Combined baseline data collection and testing of intervention**

The Chinese trial also demonstrates that it is possible to combine collection of baseline data (the negative control) with testing of an intervention. This point is probably important as it allows time and money to be saved and several objectives are accomplished at the same time (Rangnekar, 1994). Additionally, it is much easier to establish a working relationship with farmers, when the scientists undertake some work which is tangible and visible.

### **Backup on-station work**

On-farm work is incomplete unless it can count on on-station research, when a need arises. However, this linkage between the field and the station is still poorly developed and in most cases it operates the other way round, i.e., research is done on-station, which is subsequently tested in the village.

The following example on restricted suckling is therefore included, not because it was the actual sequence of events, but to illustrate how important it is to develop a well-founded, scientific understanding of sometimes unexpected occurrences in the villages; in this case, the unexpected high growth rates in the first month of the life of the calf.

### **RESTRICTED SUCKLING**

Allowing the calf to be suckled by its dam is an age-old farmer practice in many developing countries. On the basis of this custom, Ugarte and Preston (1972) in Cuba and Alvarez *et al.* (1980) in Mexico developed a restricted suckling system which demonstrated increased total milk

production in the cow and improved calf growth rate for a lower quantity of milk consumed - characteristics also found by Khan and Preston (1992) in their work in Pakistan (Table 11.1). These observations can be interpreted to support the village-based observation that calves grow well in early life, when their nutritional requirements can be met by suckled milk.

**Table 11.1. Performance of calves reared by restricted suckling or artificial rearing (Source: Khan and Preston, 1992).**

	Artificial rearing	Restricted suckling	SEM	Significance level
Liveweight, kg				
Birth	32.6	30.9	1.63	NS
At 92 d	64.4	83.1	3.12	.001
Daily gain, g	370	552	32	.001
Milk intake, kg/d	3.04	2.67	0.097	.05
Milk conversion*	8.98	4.97	0.79	.01

\* Milk consumed (kg)/Liveweight gain (kg).

While it is still poorly understood, what happens in the cow, the reactions in the young ruminant have been described as the suckled liquid milk passes through the rumen to the abomasum by the application of the oesophageal groove reflex (Ryle and Ørskov, 1990).

One interesting question to pursue is to what extent restricted suckling can be applied to lactating goats and sheep. Although the practice is known, results of research have not been reported. However, on-going work in Vietnam indicates restricted suckling can be applied to goats (Preston, T.R., personal communication).

## THE MANAGEMENT FACTOR

### The questions

As already mentioned village trials set up for one purpose may turn out to answer other questions as well or raise new ones. Data from an on-farm trial testing sugar cane juice as a source of energy to pigs in Vietnam can be used to illustrate the point.

A first analysis had revealed no relationship between initial and final pig weight, while a relationship was indicated between household management practices and pig daily gain (Figure 11.3). The next logical question to try to answer would be: what causes this difference between households?

**Figure 11.3. Influence of household on pig performance in villages in Vietnam (Source: SIDA.MSc 1992/94).**

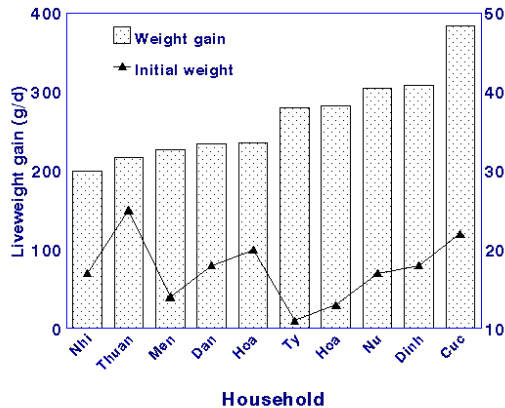

### **Organization of the work - A Women's Union and a revolving fund**

The work in Vietnam (Dolberg, 1993) has benefited strongly from collaboration with local chapters of the Vietnamese Women's Union. The Union has been responsible for selection of participating women farmers and day-to-day supervision of the trials. Initially, an agreement was worked out between the Research Project funded by Sweden (SIDA MSc, 1992/94) and the Women's Union, which stipulated obligations of both parties. An experimental fund was provided to be administered by the Union and farmers were only subsidized, if it could be demonstrated that they had encountered a loss due to the trials. However, in most cases farmers have recovered their costs and, as money is returned to the experimental fund, it allows new trials to be undertaken.

While such an arrangement may not be appropriate in all cases, in Vietnam it has proved a very effective instrument. Working with an

established development institution like the Women's Union has the advantage that, if a technology is successful and starts to spread, the transition from on-farm trials to large scale extension work can be smooth as it can happen within the same institution with a core of people who knows about the technology from the early phases of its introduction.

### **THE COMPARATIVE ANALYSIS IN TECHNOLOGY ADOPTION**

Technologies may fit under one set of circumstances, but not under another. Ammoniation of fibrous crop residues with urea as a source of ammonia has found adoption in China, Niger, Tunisia and Iran but failed in many other countries. A comparison of some relevant factors from China and Bangladesh is made in Table 11.2.

The objective here is not to discuss the specific factors, but to point out that there can be several reasons - and many of them non-technical - for adoption or rejection of technologies. Straw treatment now (autumn 1994) seems to find uptake in Bangladesh, precisely because the technology finally is receiving institutional support.

### **INTERACTION BETWEEN RESEARCH AND DEVELOPMENT**

While the examples above have been included to provide practical illustrations of on-farm work, an attempt will be made in this section to generalize on important features of the approach.

#### **Feedback**

To be able to generate feedback from farmers and deal with it constructively is, according to Bunch (1982), a most important condition for success. However, it has been difficult to put into practice (Merrill-Sands and McAllister, 1989). Doing on-farm work early, and not late, in the technology research and development process is an important means of generating feedback.

**Table 11.2. Straw utilization factors in China and Bangladesh (Source: Dolberg, 1992).**

Factors	China	Bangladesh
Plenty of straw?		
National perspective	Yes	Yes
Farmer perspective	Yes	No
Urea available	Yes	Yes
Protein supplements	Cheap	Avail.
Access to land	Even	Uneven
Share cropping	No	Yes
Price of straw	Low	High
Straw used as fuel	No	Yes
Tillage power	Tractors	Cattle
Management decisions	On-farm	Off-farm
Absentee landlords	No	Yes
Political and adm. support	Yes	No
Training of scientists	No	Yes
Socio-economic factors conducive to technical assistance	Yes	No

### **Technology - identification of strengths and weaknesses**

Instead of the conventional "from laboratory to research station; to farmer-testing; to wide-scale application through the extension system" sequence of events, it is argued that early in the technology research and development phase it is important to get out and make a test on-farm. This is not so much to promote the technology as for the project planners and scientists to learn about weak and strong points of the technology and project design. It is an iterative process and it is important to stress that this is a learning phase for the planners, project personnel, scientists and farmers alike. It is argued that, if more technologies that are claimed to be ready on the shelf for extension were subjected to this test, it would be realized that many of them are in fact not ready and, logically, research would be better focused and planning would become more realistic.

**Creation of a farmer-extension-scientist alliance**

If successful, it is likely that the iterative process outlined above will have identified leaders at farmer, extensionist and scientist levels, who by joining forces can do the necessary research and development of the technology *in situ*. This approach is still sparsely used, but teams using it can reinforce each other by communicating with collegial groups elsewhere in the World through modern means of communication. By offering scholarships to host country students (Dolberg, 1991), projects can meet several objectives at one time: baseline data can be collected, ongoing monitoring and evaluation can be conducted and future scientists and extensionists can be trained. To facilitate the approach, development projects should contain a budget line for research, as limitations in knowledge are frequently identified during project implementation.

**The methodological tool kit**

A further important reason to get out on farms is to develop and improve researchers' awareness of the methods for data collection and analyses, which can be applied under these conditions. It is by being out on farms dealing with farmers, that new ideas arise and arrangements like the revolving, experimental fund are created.

For data analysis, a graphics programme can be used to illustrate patterns and consistencies quickly as illustrated in this chapter. In fact, in many on-farm situations, it is very important to demonstrate patterns and consistencies due to factors such as location, season, age, management, breed and land tenure which, subsequently, may be subjected to more careful analysis.

There is an argument here as some scientists feel very uncomfortable without applying statistics to their data. Others find farmer uptake of technologies the most important criteria for data evaluation and -relevance (Chambers *et al.*, 1989; Pretty and Chambers, 1992). One important point is that many smallholder farmers deliberately pursue complexity in their farming practices in contrast to the standardization which is often a pre-requisite for application of conventional statistical analyses.



## **CONCLUSION: TOWARDS THE FARMER-FOCUSED RESEARCH FRAMEWORK**

To exploit fully the potential that smallholder farmers possess to increase animal production, more work is required to describe scientifically, and to understand, their current practices and to test new ones under their conditions.

The examples presented in this chapter illustrate that the objective of the first step should not be to promote a technology, but rather to identify problems some of which may require further research and development in an iterative manner.

A small start has merit as a means of testing the basic idea before proceeding to large-scale application of a technology. It is a means of identifying farmers, researchers and extensionists who have a natural talent for this type of work and an alliance of such people is critical for future expansion of smallholder livestock production. If the technology is a failure, it is easier to redirect or close down a small project than a big one.

When a critical mass of people and institutions are identified then on-farm work will accelerate the research process and make it move faster than if the scientists confine themselves to the research station and laboratory, or the farmers to their farms.

An important condition for success is that the leading scientists should:

- Take the approach seriously.
- Be prepared to spend time in the field with farmers in order to identify topics for on-farm and on-station research.
- Demonstrate to their juniors how to deal constructively with feedback from farmers.

## Chapter 12

## Guidelines for the evaluation of feed resources

*The proposals in this chapter are intended to assist researchers in allocating priorities to the activities needed to arrive at decisions concerning the potential role of a feed resource in the farming system. The categories into which resources should normally be allocated are indicated, namely: basal feeds or supplements for monogastric or ruminant animals; biomass for fuel or as soil conditioner.*

*Evaluation procedures begin with discussions with farmers and processors and lead on to simple tests (in sacco or in vitro estimates of degradability) to assess availability to micro-organisms (and gastric enzymes) terminating with feeding trials with target animals to define surface response functions to major supplementary nutrients.*

### INTRODUCTION

What is the minimum information required in order to identify and classify feed resources for the functions set out in Chapters 3 to 6? It seems that the classical system of proximate analysis and even the more sophisticated methods for identifying the components of plant cell walls (i.e., ADF and NDF) contribute little information for the development of feeding systems which aim to efficiently utilize tropical feed resources.

In the industrial countries, livestock nutritionists have had as their final goal the determination of absolute requirements for nutrients for the diverse production functions of livestock: growth, fattening, milk production, reproduction etc. These goals are less relevant to the less-developed countries, especially those in the tropics, partly because of ecological differences, but to a greater extent because the economic climate is completely reversed. In all industrial countries, with the exception of New Zealand and to some degree Australia, state subsidies provide a large proportion of the revenue received by farmers. This leads

to a situation where fixed costs are high (e.g., opportunity price of land and of labour) which obliges farmers to maximize individual animal productivity and feed conversion efficiency. The support price for animal products (or indirect subsidies such as cheap irrigation water and fossil fuel) further encourage the farmer to aim for maximum productivity. A highly evolved marketing system presents a range of feeds to the producer, many of them imported, and encourages the use of least cost formulations that require decisions about both cost and nutrient availability. The consequence is that nutrient requirements reflect mainly biological rather than economic criteria.

In almost all less-developed countries, agriculture is not subsidized and the producer must manage the farm enterprise to secure optimal economic returns to inputs. Because of the law of diminishing returns, the levels of animal productivity where economic response is optimized are lower than those where biological response is maximized. The outcome of this change of emphasis is that farmers in the less-developed countries need production function criteria (production response to change in nutrient supply) rather than the absolute levels of nutrients for a given level of production.

The range of feeds available to smallholder farmers is mainly restricted to what can be grown on the farm, and distance from formal markets means that few of the available alternatives have an opportunity price. Socio-economic criteria at family level also strongly influence the choice of crops and methods of processing.

To provide the kind of information that is required in this complex socio-economic environment demands a more pragmatic approach to feed evaluation which emphasizes acquiring knowledge about a resource (usually from the farmers themselves) and finally establishing the basis of the feeding system by means of practical feeding trials.

### **DEFINITION OF CROP RESIDUES, Agro-industrial BY-PRODUCTS AND PRIMARY PLANT PRODUCTS**

Crop residues are invariably fibrous, of low digestibility, and low in nitrogen. They are produced on the farm and therefore widely spread geographically. On small farms in developing countries they form the principal feed of ruminant livestock during the dry seasons.

Agro-industrial by-products result from the processing of crops such as oilseeds, sugar cane, oil palm, sisal, citrus, pineapple and bananas; or the slaughter and processing of livestock and fish. They are geographically restricted to the factory sites, are usually marketed and frequently exported to earn foreign exchange. They are rich in protein (oilseeds and meals of animal origin) or sugar (molasses, citrus and pineapple pulps) and occasionally in starch (reject bananas, cassava peels) and usually low in fibre. Exceptions are sugar cane bagasse, palm-press fibre, coffee pulp and cocoa pods.

Primary plant products of interest in tropical countries, especially as alternatives to cereal grains, are the juice from sugar cane and sugar palm, the oil and the fresh fruit from the African oil palm, and the roots from cassava and sweet potato. Leaves and foliage from multi-purpose trees and shrubs, from certain crop plants and from water plants are also in this category.

### **CATEGORIES OF BY-PRODUCTS**

It is convenient, when establishing principles for evaluating new feed resources, to allocate them to one of five categories:

#### **Category 1:**

Feed resources high in fibre and low in nitrogen: these include the most important crop residues, namely cereal straws and stalks, legume haulms and straws and cereal stovers.

#### **Category 2:**

Feed resources high in fibre and relatively high in nitrogen: in this category are animal excreta, brewers' grains and leaves and foliages from trees, shrubs and water plants.

#### **Category 3:**

Products and by-products low in fibre and low in nitrogen. This category includes products and by-products from processing of: sugarcane and sugarpalm (e.g., juice and molasses), cassava (roots, peel, bran and fines), citrus and pineapples (pulp), bananas (rejected fruit) and other products from food processing plants (e.g., broken biscuits).

**Category 4:**

By-products low in fibre and high in nitrogen: this group comprises mostly oil seed cakes and meals and slaughter offal.

**Category 5:**

By-products high in oil and in fibre and low in nitrogen; the fruit, palm press fibre and "mud" from the processing of the African oil palm are in this category.

**ASSESSING NUTRITIVE VALUE**

In discussing guidelines for research on tropical feed resources, it is convenient to consider the different objectives relating to their use. To a major extent the role of the resource in the farming system will depend on its chemical and physical properties. Answers are thus required to the following questions:

- What will be the likely role in the farming system of a relatively unknown resource?
  - As the basal diet of monogastric or ruminant animals?
  - As a supplement to the basal diet of either of these major species?
  - As a source of fuel?
  - As a source of soil nutrients including carbon?
- How can tests be done quickly and cheaply to assess the value as feed, fuel or soil conditioner of the resource?
  - The digestibility of the organic matter (categories 1, 2 and 5)
  - The availability of the nitrogen for micro-organisms (category 2)
  - The "by-pass" or "escape" properties of the protein for ruminants (category 3)
  - The amino acid balance (relative to the 'ideal' protein for monogastric species (category 3)
  - How to protect the protein or the oil for feeding to ruminants (categories 4 and 5)
  - Does the product contain secondary plant compounds and how can these be neutralized?
- How can the resource, if suitable as a feed, be used best in feeding systems with other locally produced resources?

## HOW TO CATEGORIZE THE RESOURCE

In order to establish a framework for evaluation procedures, it is convenient to make the approach in an iterative fashion as illustrated in Figures 12.1 and 12.2.

**Figure 12.1. The first steps in evaluating a new feed resource are: discussions with farmers/processors; assess degradability (digestibility); decide on end use (feed or fuel or soil conditioner or suitability for ammoniation); analyze for N and lipids.**

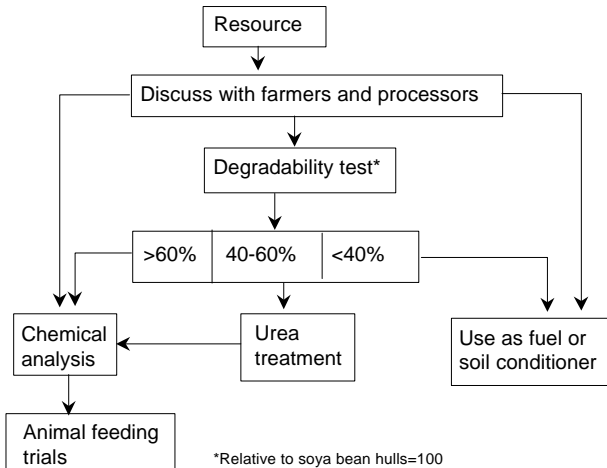

## The role of the resource in the farming system

The first step is to learn about the origin of the resource: whether it is a primary plant product, a residue or a by-product. To learn about primary plant products, it is best to talk to farmers in the area where the plant, shrub or tree is grown. The same applies to crop residues. Much valuable information can be gained by understanding harvest procedures, seasonal and soil effects and the nature of the farming system where the resource is produced.

In the case of agro-industrial by-products, it is advisable to visit the factory, farm or household, where the processing is carried out. Certain agro-industrial processes vary little among countries and continents (e.g.,

industrial processing of sugarcane, solvent extraction of oilseeds). However, at artisan level, processing methods vary widely even for the same product. In this case it is essential to talk with the owner/operator of the equipment used for the processing in order to understand fully the procedures that are being used.

The information gained in this informal survey will facilitate making the initial decision as to the potential role of the resource in the farming system and, in many cases, will permit the allocation of the resource to one or other of the above categories.

### **Assessing relative degradability**

There are two ways of assessing the potential rate of degradability of the resource by micro-organisms:

- Rate of loss of organic matter from either: nylon bags incubated in the rumen of fistulated animals (*in sacco*) or: from an incubation medium (*in vitro*).
- Rate of gas production in an *in vitro* system

Choice of one or other of these methods will be determined by many factors. The use of rumen-fistulated animals as incubators has the advantages of low cost and independence of power supplies and expensive equipment (e.g., electrical incubators and *in vitro* apparatus). The environment in the rumen can be varied easily by manipulating the animal's diet, which enables a wider range of studies to be done than is possible with *in vitro* systems. On the negative side is the ethical question of (unnecessary) surgical manipulation of the animals. Most *in vitro* systems also require a fistulated animal as a source of inoculum although there are alternatives (the rumen from a recently slaughtered animal), fresh faeces or rumen liquor obtained with a stomach tube).

In any event, the objective in general is to be able to classify the resource relative to a given standard, and not to derive an absolute value. Data derived from *in vitro* and *in sacco* methods are frequently treated as absolute values and used in regression equations to predict parameters of nutritive value, such as digestible and metabolizable energy content and intakes.

In the opinion of this author, the feed value of a resource can only

be measured reliably in a practical feeding trial in the context within which the resource will be used. The purpose of the "degradability" test is to provide additional information to that gleaned in "stage1" so as to classify more precisely the potential of the resource and the category into which it should be put as the basis for future evaluation procedures.

In view of the need to obtain relative data, it is necessary to incubate simultaneously with the unknown feed a product of known degradability which is easily reproducible and of relatively constant composition (e.g., soya bean hulls). Details of recommended methods are in Chapter 9,

On the basis of relative degradability values the following steps will be as indicated in Figure 12.1. If the degradability:

- exceeds 60% of that of soya bean hulls then proceed to chemical analysis and feeding trials with animals;
- is between 40 and 60% of soya bean hulls, then make tests of ammoniation by urea treatment. If this leads to an improvement in degradability then proceed as above; or
- is less than 40% of soya bean hulls, then the resource is best used as fuel or as a soil conditioner (source of carbon for soil micro-organisms).

### **Chemical analyses**

Some simple chemical analyses should be done. The most important are dry matter (DM), nitrogen (N), ash (to estimate organic matter [OM]) and lipids. Other analyses such as for cell wall constituents (Van Soest, 1983) can be carried out if deemed necessary or appropriate. However, the most important information, at this stage, is simply the contents of DM, OM, lipids and N.

### **Availability of the nitrogen for micro-organisms**

The methods used are the same as for degradability. The difference is that a standard substrate, rich in cell walls and low in N is used as the feed/medium, and the test resource is added in graded amounts to the animal's diet (or to the medium for *in vitro* methods). The reference standard in this case will be urea at the same level of N as in the test resource. The result is the rate of degradability of the test feed relative to urea. Ammonia levels in the rumen, or in the media, could also be the basis of the comparison.



**The "by-pass" characteristics of the protein for ruminants**

Differentiation between N sources which provide amino acids or ammonia can generally be achieved on the basis of knowledge of the source of the feed and on the method of processing. For example, the N in freshly cut grasses is usually highly soluble and therefore available for micro-organisms in the rumen or caecum. The soluble N fraction is less in herbaceous legumes and even more so in leguminous trees and shrubs. The potential of the feed to have appreciable by-pass protein will in general be inversely related with the solubility of the N.

The solubility of the N in water or in an incubation medium containing rumen micro-organisms (or with proteolytic enzymes) will give a chemical assessment of the likely solubility (the inverse of the by-pass property) of the protein.

Measuring the protein-precipitating capacity of secondary plant compounds present in the feed (e.g., for tanniferous plants, shrubs and trees) is another indirect way of measuring potential by-pass characteristics (see Chapter 9).

A more direct way of measuring protein by-pass properties is the wool growth assay (See Chapter 9).

**The amino acid balance of the protein for monogastric animals**

Equipment for estimating amino acids is expensive to purchase, maintain and operate. It is not recommended under the conditions found in most less-developed tropical countries. For most protein-rich feed resources derived from oilseeds, cereal by-products and animal slaughter, analytical data are available (e.g., Tropical Feeds, 1994) which can serve as a guide as to the likely balance of amino acids.

For new protein-rich feed resources, especially those of foliar origin, a biological chick assay is proposed (Chapter 9) which is simple and easy to carry out even in the absence of laboratory facilities.

**How to "protect" protein for ruminants**

There is no sure method that can be recommended for use on smallholder farms. Toasting and extrusion of the feed is appropriate for oilseed meals in the feed mill as may be dehydration of foliages. Reacting with formaldehyde has been used commercially in industrial countries but there are doubts as to the safety of the method for more widespread use.

None of these methods is feasible on smallholder farms. Sun-drying will have some positive effect in reducing protein solubility. Research is in progress to investigate the possibility for mixing tannin-rich feeds with those rich in protein but low in tannins. However, no recommendation can be made at this stage, other than to encourage further research in this area.

### **How to "protect" oil for ruminants**

The availability of palm oil, and even fat from animal slaughter, at competitive prices has opened up the possibility of using these resources as supplements in ruminant diets. Too high a concentration of these substances in their "crude" form (more than 4-5% in dry matter) may depress microbial activity in the rumen. Therefore, it is desirable to "protect" them so that they interfere to a minimum extent in rumen metabolism. Reacting the oil/fat with about 20% of its weight as calcium hydroxide, with or without prior saponification, appears to be a simple and effective method. Combining these two elements with protein-rich foliages, in a homogeneous mixture, seems to generate synergistic effects which enhance the efficiency of using both the oil and the protein (Chapter 6).

## **THE TARGET ANIMALS**

Once the resource is categorized as either a potential basal diet or a supplement, the next step is to derive surface response curves relating levels of supplement to rate of production and/or efficiency of feed utilization (Figure 12.2).

### **Ruminants**

If the feed resource is to be used as the basal diet for ruminants, then it is useful to evaluate first the advantage or otherwise of offering the resource at a normal (20% refusals) or high (100% refusals) level to facilitate selection. In this test, rumen supplements (sources of ammonia, S and minerals; and some "highly digestible" green forage) should also be given to ensure these are not limiting in the basal diet. These could be free access to a molasses-urea block and legume tree foliage or fresh grass at about 3 kg (fresh basis) per 100 kg live weight.

**Figure 12.2.** The final steps in evaluation of a feed resource are: determine if suitable for basal diet or as supplement; if basal diet then evaluate at offer levels to give 20% or 100% refusals; if a supplement then add graded levels and determine surface response functions to N, "green" forage and "by-pass" protein.

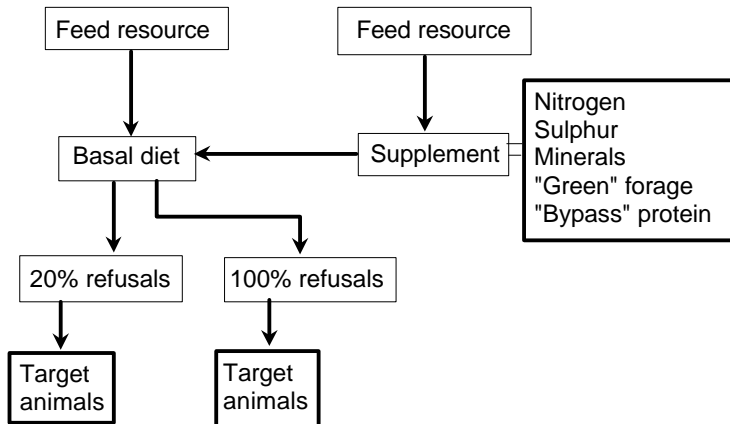

Having decided on the offer level it may be necessary to assess the need for the rumen supplements. This can be done with a 2 x 2 factorial arrangement of two treatments: access or not to a urea supplement (e.g., the molasses-urea block); and access or not to a source of digestible green foliage. An excellent example of this kind of trial is that reported by Ocen (1992) who evaluated the need for rumen supplements on a basal diet of maize stover (Figure 6.5).

The final step is to derive the surface response relationship between the selected production trait and the source of by-pass protein. The latter may be as a protein-rich oilseed meal (e.g., cottonseed meal) or a tree foliage (e.g., *Gliricidia sepium*). At least five levels should be used with 2 to 3 replications of each level. Examples of this type of evaluation are those with basal diets of molasses in Cuba (Figure 5.1), chopped and derinded sugarcane in Mexico (Figure 5.10) and ammoniated (urea-treated) rice straw in Bangladesh (Figure 5.5) and wheat straw in China (Figure 5.11).

**Monogastric animals**

The question will usually relate to the suitability of a feed resource (i) to replace cereal grain as the basal diet, or (ii) to serve as a partial or total replacement of the conventional protein supplement which is usually soya bean meal. Knowledge about the feed will usually be sufficient to identify feeds likely to have potential as a replacement for cereal grain as the basal diet. Feed resources such as sugarcane and sugar palm juice, cassava roots, sweet potato tubers, and the fruit of the African oil palm obviously fall into the category of the basal diet of pigs. No prior chemical analysis is necessary in order to make such a decision. Appropriate experimentation may be to evaluate the degree of replacement of the standard cereal grain as was done for pigs in the case of the African oil palm fruit (Table 4.6). Where use of cereal grain is not a viable alternative, it may be more convenient to proceed immediately to on-farm trials as was done in the case of the sugar palm juice in Cambodia (Figure 4.3).

On-station experimentation may be called for to establish surface response curves to a protein supplement. The approach here (Figure 3.2) is similar to that for establishing responses to "by-pass" protein in ruminants. Unconventional sources of protein such as those derived from water plants and tree leaves require a different approach. The problem here may be one of acceptability, often due to the presence of secondary plant compounds. Drying or ensiling are simple ways of neutralizing some of these substances as has been demonstrated for cassava leaves where the toxic glucosides can be reduced to harmless levels by either of these methods (Table 4.8). Simple observation trials are all that is needed to establish the need or otherwise of prior processing. The next step is to assess the effect of degree of replacement of the conventional protein source by the test foliage which calls for a similar experimental design as in assessing surface response functions.

## Chapter 13

## Presentation of research results

*Computers and related electronic means of communication are revolutionizing the way research data are collected, analyzed, presented and transmitted. Boundaries between scientists and countries are no longer a constraint and it is now much easier to build up critical masses of scientists working in a given subject area. It will facilitate much-needed inter-disciplinary work as the few scientists who have responded to this approach now communicate much more easily.*

*These technologies are becoming increasingly more accessible to researchers in developing countries but there are still countries and regions within countries where the necessary infrastructure is not in place. Donor agencies and national and international policy makers should put correction of these deficiencies very high on their agenda.*

### INTRODUCTION

Research which does not get presented or published, but remains in the mind or the desk of the researcher, is better never to have been started in the first place. Plans should be made at the beginning concerning the how and the where of dissemination of the data. As indicated in Chapter 10, the first recipient of the information should be the farmer, in the case of trials on farms; while for on-station work the researcher's immediate colleagues should be kept informed at all stages.

It has never been easier to obtain the tools needed for rapid dissemination of results either as presentations at seminars or workshops, or as a scientific article. The possibilities offered by the present generation of 486 notebook computers (less than US\$2,000) and appropriate programs are exciting. As Andrew Speedy has said, "With the new information technologies, researchers in developing countries can leap-frog into the future, even by-passing their colleagues in the more-developed countries who are still tied by copyright restrictions and the power of the large publishing houses who are reluctant to relinquish their

control of the means of communication".

A researcher can travel to a workshop with a "notebook" computer and portable printer and a box of acetates (usually specially-coated ones for ink jet printers), and prepare her/his entire presentation the night before the event.

There are at present four computerized journals dealing with tropical animal production (Livestock Research for Rural Development, first published by CIPAV in 1989; Revista Latinoamericana de Investigación en Pequeños Herbívoros No-rumiantes, first published in December 1993; Índice Venezolano de Investigaciones en Producción Animal, first published in January 1994; Revista Computadorizado de Producción Porcina, first published by Instituto de Investigación Porcina, Cuba in September 1994).

Livestock Research for Rural Development will publish a paper in less than three weeks of receipt if it is prepared in the correct format (as an ASCII file) and refereed by two established scientists in the author's own country. The editorial board will also help researchers in the analysis and presentation of their data. The distribution of the journal, originally only on diskette, is now increasing because it is available by electronic mail. It is held as a conference on several bulletin board services (BBS) (e.g., on GreenNet in the UK, which services much of Africa, and on CIPAV in Colombia). It can also be accessed on the Internet by World Wide Web. So the barriers which faced researchers in tropical animal production in developing countries in having their work published are fast being swept away.

In any event, it is becoming increasingly less relevant to seek publication in main-line journals, perhaps mainly for prestige purposes. The costs of acquiring conventional journals (often in excess of US\$700/volume) put them out of reach (and out of consultation) of the majority of researchers in developing countries. Many of these journals have page charges (in hard currency!) which workers in many developing countries have no chance of paying. The research that many of these journals publish is increasingly less relevant to the objectives of a world where resources must be used sustainably.

## **THE ROLE OF COMPUTERS**

As stated in Chapter 10, computers - especially the portable notebooks - are an essential tool of today's researchers. Starting from the experimental plan and a review of the relevant literature, all information should be entered into the computer in an appropriate software package. This manual in no way endorses any one particular product or company, but experience in developing countries shows quite clearly that communication on a wide basis is facilitated when use is made of IBM-compatible machines. It is also a great help in the presentation and dissemination of information to aim for compatibility (with your advisers, with the computerized journals and with the relevant Bulletin Boards) in the use of programs. The required software is for: word processing, graphics and presentations, a spreadsheet and statistical analysis. The important point is to work with a group of programs that interface well together, and not to waste time venturing off into new and exotic (but less well tried) programs that promise to do more than the standard packages.

## **E-MAIL**

Every researcher should find a way to join an e-mail network. Packages are available now which facilitate setting up a network communicating over standard telephone lines. The CIPAV network in Cali, Colombia transmits and receives messages nationally and internationally at over 600 cps (characters per second) which is the equivalent of about one page in 4-5 seconds. It runs on a 386 notebook computer and a 14,400 Baud modem. Total cost of the unit is less than US\$2,500. Connection to an email network is the door through which contact is made with computerized journals, tele-conferences and messages from colleagues. It is a means of access to sympathetic advisers ready to help with ideas and information, and to friendly sources of data such as "Tropical Feeds" (most data bases are highly unfriendly, especially when you have to consult them on-line at in a country where telephone charges are high).

It is the modern means of communicating your ideas and results. It has become the special medium of the NGOs (witness the highly appropriate objectives and activities of the Association for Progress in Communications, APC) and those individuals and groups concerned with the sustainable use of natural renewable resources.

It need not be expensive (it is almost always cheaper than sending

messages by fax) and it will rapidly become more accessible and more efficient. It is relevant to point out that e-mail links have been widely used in the preparation and editing of this manual. In fact, without e-mail the publication would have been delayed at least by several months.

## **PRESENTATIONS**

This topic deserves a slightly higher priority than publications as probably it will be the first medium in which the researcher will present their data. Today and in almost any country in the world there is no excuse for a bad presentation. Top quality presentations can be made using as tools a notebook computer, an ink-jet printer and some plotter acetates, backed up with an appropriate graphics package, Colour printers are still a luxury for most researchers and offer only minor advantages over black and white printing, judiciously touched up with coloured marker pens. In general, acetates for overhead projection are more appropriate and reliable than 5 cm slides which need a darkened room, a good photo-laboratory and time. Good slides cannot be produced 2 hours before your presentation; but an acetate can be done half an hour before and still be of excellent quality. The instructions and the tools on most graphics packages are so comprehensive now that the rules of:

- only 5-6 lines per page, and
- letters at least 5 mm in height,

are rarely necessary any more. Bad overheads are still made even with the help of computers, but the frequency of such occurrences is decreasing.

What is not allowable is to take printed text output from a computer or a typewriter (or a table or a graph from a book) and copy it on to an acetate. The results will almost always be bad because you will have broken the rules set out above.

Overhead transparencies are not just for the results. They also substitute for your hand-held notes. Reading from a prepared script is absolute taboo!! This is the resort of politicians who are frightened of being misinterpreted and/or mis-quoted or who hire others to think for them.

Provided you limit the amount of information on your overheads and they are mainly self-explanatory, you can expect to use efficiently one overhead per minute of your presentation.



**PUBLICATIONS**

Reference has already been made to the advent of computerized journals and the advantages they offer. Coming soon to join computerized publications such as Tropical Feeds is the electronic library which in developing countries will be dedicated initially to making available the more relevant information such as the reports and proceedings of conferences and workshops. Increasingly what has been considered to be "grey" literature will enter into the mainstream through the electronic "highway".

All these new services will use electronic means of communication. Researchers must rapidly become familiar with the medium if they intend to be at the forefront of their profession.

**TELE-CONFERENCES**

Just as computerized journals are replacing the conventional printed ones, so "tele-conferences" are predicted as the alternative to the conventional "face-to-face" conferences. So far the promises have not fulfilled the high expectations. The two most recent tele-conferences in the area of livestock production on "The Role of Livestock in Development" and "Sustainability Indicators" (Inforum, 1993, 1994), have suffered from dominance by participants from developed countries, and from Official Development Agencies. This has been due mainly to the ease of access to electronic networks and their use by resource persons in North America especially, since that is where electronic mail is most widely used, and - by default - the inadequate participation of resource persons from the less-developed countries. This is no reflection on the organizers - simply the reality of the means of communication being most developed where the power lies. However, as stated earlier, the situation is changing rapidly. The next move must be to organize such conferences from less-developed countries, on themes of immediate concern to resource persons in those countries, such as for example the topics in this manual.

## References

- Aboud, A.A.O., Owen, E., Reed, J.D. and McAllan, A.B.** 1990. Feeding sorghum stover to Ethiopian sheep: effect of stover variety and amount offered on growth, intake and selection. *Animal Production* 50: 593.
- Alvarez, F.J., Saucedo, Z., Arriaga, A. and Preston, T.R.** 1980. Effect of milk production and calf performance on milking crossbred, European Zebu Cattle in the absence or presence of the calf, and rearing their calves artificially. *Tropical Animal Production* 5:25-37.
- Alvarez, F.J. and Preston, T.R.** 1976. Studies on urea utilization in sugar cane diets: effect of level. *Tropical Animal Production* 1:194-201.
- Amir, P. and Knipscheer, H.C.** 1989. Conducting on-farm research animal research: Procedures and economic analysis. Winrock International Institute for Agricultural Development and International Development Research Centre. Little Jean Mountain, Arkansas.
- Arango, M.F, Rodríguez L. and Salazar P.** 1994. Lombriz roja californiana y *Azolla-Anabaena* como sustituto de la proteína convencional en dietas para pollos de engorda. Report to IFS: Stockholm.
- ARC.** 1984. The nutritional requirements of ruminant livestock. Supplement Number 1, Commonwealth Agricultural Bureaux, Slough.
- Atta-Krah, A.N.** 1991. Fodder trees and shrubs in tropical Africa: importance, availability and patterns of utilization. In: Integration of livestock with crops in response to increasing population pressure on available resources (Editors: T R Preston, M Rosales and H Osorio). CTA: Ede, Netherlands.
- Babatunde, G.M.** 1992. Availability of banana and plantain products for animal feeding. In: Roots, tubers, plantains and bananas in animal feeding. FAO Animal Production and Health Paper No. 95. FAO. Rome pp251-276.
- Balcells, J., Guada, J.A. and Peiro, J.M.** 1992. Simultaneous determination of allantoin and oxypurines in biological fluids by high-performance liquid chromatography. *Journal of chromatography* 575:153-157.
- Balcells, J., Guada, J.A., Castrillo, C. and Gyasa, J.** 1991. Urinary excretion of allantoin and allantoin precursors by sheep after different rates of purine infusion into the duodenum. *Journal of agricultural Science (Cambridge)* 116:309-317.
- Barry, T.N. and Blaney, B.R.** 1987. Secondary compounds of forages. In: The nutrition of herbivores. (Editors: Hacker, J.B. and Ternouth, J.H.). Academic Press. Australia. pp 91-119.

- Barry, T.N. and Manley, T.R.** 1986. Interrelationships between the concentration of condensed tannin, free condensed tannin and lignin in *Lotus* spp and their possible consequences in ruminant nutrition. *Journal of the Science of Food and Agriculture* 37:248 - 254.
- Basile, F. and Machado, P.F.** 1990. Feeding value of steam treated sugar cane bagasse in ruminant rations. *Livestock Research for Rural Development* 2(1):1-6.
- Becerra, M., Ogle, B. and Preston, T.R.** 1994. Evaluation of fattening system for growing ducks based on aquatic plants and sugar cane juice. (MSc Thesis in Sustainable Livestock Production, Swedish University of Agricultural Sciences, Uppsala).
- Becerra, M.** 1991. *Azolla-Anabaena*; un recurso valioso para la producción agropecuaria en el trópico. Serie de Manuales Técnicos #1 pp1-53.
- Bien-aime, A. and Denaud, L.** 1989. Feuilles de velvet bean et jus de canne-a-sucre pour la complémentation du lapin en haiti *Livestock Research for Rural Development*. 1(1): 31-35.
- Bird, S.H. and Leng, R.A.** 1984. Further studies on the effects of the presence or absence of protozoa in the rumen on liveweight gain and wool growth of sheep. *British Journal of Nutrition* 52: 607-611.
- Blockey, M.A. de B.** 1980. Testicle size in bulls *Proceedings of the Australian Society of Animal Production* 13:52-53.
- Blummel, M. and Ørskov E.R.** 1993. Comparison of *in vitro* gas production and nylon bag degradability of roughages in predicting feed intake in cattle. *Animal Feed Science and Technology* 40: 109-119.
- Bobadilla, M. and Preston, T.R.** 1981. The use of sodium bentonite and ammonium hydroxide (aqueous NH<sub>3</sub>) as preservatives for sugar cane juice. *Tropical Animal Production* 6:345-349.
- Boodoo, A.A., Ramjee, R., Hulman, B., Dolberg, F. and Rowe, J.B.** 1990a. Effect of supplements of balanced concentrates and cottonseed cake on milk production in Mauritian villages. *Livestock Research for Rural Development*. 2(1):7-15.
- Boodoo, A.A., Ramjee, R., Hulman, B., Dolberg, F. and Rowe, J.B.** 1990b. Evaluation of the basal forage diet of village cows *Livestock Research for Rural Development*. 2(1): 15-23.
- Borchers, R.** 1977. Allantoin determination. *Analytical Biochemistry* 79:612-613.
- Botero, R. and Preston, T.R.** 1987. Biodigestor de bajo costo para la producción de combustible y fertilizante a partir de excretas Manuscrito ineditado: CIPAV, Cali, Colombia.

- Brown, L.R., Durning, A., Flavin, C., French, H., Jacobson, J., Lenssen, N., Lowe, M., Postel, S., Renner, M., Ryan, J., Starke, L. and Young, J.** 1991. State of the World 1991. Worldwatch Institute Report. W.W. Norton and Company: New York pp 251.
- Brumby, P.J.** 1987. Foreword. In: Matching Ruminant Production Systems with Available Resources in the Tropics and Subtropics. PENAMBUL Books Ltd: Armidale NSW, Australia.
- Brundtland Report.** 1987. Our Common Future. World Commission on Environment and Development. Oxford University Press.
- Buckingham, K.W., Ela, S.W., Morris, J.G. and Goldman, C.** 1978. Nutritive value of nitrogen-fixing aquatic fern, *Azolla filiculoides*. Journal of Agriculture and Food Chemistry 26: 1230-1234.
- Bui Van Chinh, Le Viet Ly, Nguyen Huu Tao, Pham Van Thin and Preston T.R.** 1992. Ammoniated rice straw or untreated straw supplemented with a molasses-urea block for growing Sindhi local cattle in Vietnam. Livestock Research for Rural Development, 4(3):6-9.
- Bui Xuan An, Ngo Van Man, Duong Nguyen Khang, Nguyen Duc Anh and Preston T.R.** 1994. Installation and Performance of Low-cost Polyethylene Tube Biodigesters on Small Scale Farms in Vietnam: In: Proceedings of National Seminar-workshop "Sustainable Livestock Production On Local Feed Resources" (Editors: T R Preston, B Ogle, Le Viet Ly and Lu Trong Hieu), Ho Chi Minh City, November 22 - 27, 1993 pp95-104.
- Bui Xuan An, Luu Trong Hieu, Duong Khang Nguyen and Preston T.R.** 1992. Effect of position in the tree and pretreatment of *Acacia mangium* leaves on rumen dry matter and nitrogen degradabilities. Livestock Research for Rural Development, 4(2):7-12.
- Bui Huy Nhu Phuc, Ogle, B. and Preston, T.R.** 1994 Effect of Protein Level in Reconstituted Sugar Cane Juice Based Diets for Growing Pigs. In: Proceedings of National Seminar-workshop "Sustainable Livestock Production On Local Feed Resources" (Editors: T.R. Preston, B. Ogle, Le Viet Ly and Lu Trong Hieu), Ho Chi Minh City, November 22 - 27, 1993 pp 45-50.
- Bui Xuan Men and Vuong van Su.** 1992. Sugar cane products in diets of ducks. Livestock Research for Rural Development, 4(3):10-14.
- Buitrago, J.** 1990. La yuca en la alimentación animal. CIAT: Cali, Colombia.
- Buitrago, J.** 1964. Utilización de la yuca en dietas para crecimiento y ceba de cerdos. Universidad Nacional de Colombia, Bogota (Thesis).
- Bunch, R.** 1982. Two Ears of Corn - A guide to People-Centered Agricultural Improvement. World Neighbours, USA.
- Cardozo, A.** 1993. El rol de los pequeños herbívoros no-rumiantes en los sistemas de producción animal. Revista Latinoamericana de Investigaciones en Pequeños Herbívoros No-rumiantes. Volumen 1, Numero 1, artículo 1.

- Chambers, R., Pacey, A. and Thrupp, L.A.** 1989. Farmer First. Farmer Innovation and Agricultural Research. Intermediate Technology Publications London.
- Chambers, R.** 1983. Rural development: Putting the last first Longmans:Harlow, UK.
- Chen, X.B., Ørskov, E.R. and Hovel, F.D. De B.** 1991. The use of intragastric infusion in studies on excretion of purine derivatives as a measure of microbial protein supply in ruminants: differences between cattle and sheep. *British Journal of Nutrition* 63:121-129.
- Chen, X.B., Ørskov, E.R. and Hovel, F.D. De B.** 1990b. Excretion of purine derivatives by ruminants: In: Protein metabolism and nutrition (Editors: B.O. Eggum, S. Boisen, C. Borsting, A. Danfaer and T. Hvelplund) Volume 2, pp 67-70, National Institute of Animal Science, Foulum, Denmark.
- Chen, X.B., Hovel, F.D. De B., Ørskov, E.R. and Osuji, P.O.** 1992. Effect of feeding frequency on diurnal variation in plasma and urinary purine derivatives in steers. *Animal Production* 55:185-191.
- Chen, X.B., Kyle, D.J. and Ørskov, E.R.** 1993. Measurement of allantoin in urine and plasma by high-performance liquid chromatography with pre-column derivatization. *Journal of chromatography* 617:241-247.
- Chen, X.B., Hovel, F.D. De B., Ørskov, E.R. and Brown, D.S.** 1990a. Excretion of purine derivatives by ruminants: effect of exogenous nucleic acid supply on purine derivative excretion by sheep. *British Journal of Nutrition* 63:131-142.
- Chowdhury, S.A., Huque, K.S., Khatun, M. and Nahar Quamrun.** 1994. Study on the use of algae as a substitute of oil cake for growing calves. *Livestock Research for Rural Development*. 6(3) (In Press).
- Christiansson, C.** 1988. Degradation and rehabilitation of agropastoral land - perspectives on environmental change in semiarid Tanzania. *AMBIO* 17:144-152.
- Christiansson, C., Hultnas, C.A., Loftas, C., Skarpe, C. and Spornly, E.** 1987. Livestock integration in soil conservation programmes. Report from a mission to Dodoma region, Tanzania. SIDA: Stockholm.
- CIAT.** 1978. Informe Anual. Centro Internacional de de Agricultura Tropical: Cali, Colombia.
- CIPAV.** 1987. Ajuste de los sistemas pecuarios a los recursos tropicales Suplemento Ganadero (Bogota, Colombia) 7:1-72.
- Clark, J., Preston, T.R. and Zamora, A.** 1972. Final molasses as an energy source in low-fibre diets for milk production 2: Effect of different levels of grain. *Revista Cubana Ciencia Agricola (English Edition)* 6:27-34.
- Coley, P.D., Bryant, J.P. and Chapin, F.S.** 1985. Resource availability and plant anti-hervivore defense. *Science*, 230: 895-899.

- Cuellar, P., Rodriguez, L. y Preston, T.R.** 1992 Uso del pizamo (*Erythrina fusca*) como suplemento proteico en dietas de tallo de caña prensado para terneras de levante. *Livestock Research for Rural Development* 4(1): 1-10.
- Daly, H.E.** 1993. The perils of free trade. *Scientific American* November 24-29.
- Daniels, P.W., Holden, S., Lewin, E. and Dadi, S. (Editors)** 1993. *Livestock services for smallholders. Proceedings of a Seminar.* Yogyakarta, Indonesia. Indonesia International Animal Science Research and Development Foundation.
- Del Río, J., Pineda, A. y Chao, R.** 1980. Criterios tecnológicos en el diseño de nuevas plantas procesadoras de desperdicios alimenticios. *Ciencia y Técnica en la Agricultura: Ganado Porcino* 3(3):35-43.
- Dentin ho, M.T., Khazaal, K., Ribeiro, R. and Ørskov, E.R.** 1994. Prediction of digestibility and intake of sheep fed Leguminosae or Graminae hays: comparison between the *in vitro* digestibility, kinetics of gas production or dry matter degradation. *Proceedings of the Winter Meeting of the British Society of Animal Production*, 21-23 March, Scarborough, England.
- Depres, E., Naves, M., Tamisier, F., Xande, A. and Rinaldo, D.** 1994. Growth performance and meat quality of Large White and local pigs reared in the tropics. *Livestock Research for Rural Development*. 6(2): 23Kb.
- Deschamps, A.M., Otuk, G., Lebeault, J.M.** 1983. Production of tanase and degradation of chesnut tannin by bacteria. *Journal of Fermentation Technology*. 61:55.
- Devendra, C.** 1992. Non-conventional feed resources in Asia and the Pacific. FAO-APHCA Publication No 14 (4th edition). FAO: Bangkok pp46-54.
- Diaz, A., Avendano, M. and Escobar, A.** 1993. Evaluation of *Sapindus saponaria* as a defaunating agent and its effects on different ruminal digestion parameter. *Livestock Research for Rural Development* 5(2):1-6.
- Diez, M.T., Arin, M.J. and Resines, J.A.** 1992. Simultaneous determination of allantoin and creatinine in urine by a rapid reversed-phase liquid chromatography method. *Journal of liquid chromatography* 15:1337-1350.
- Dinh Van Binh, Bui Van Chinh and Preston, T.R.** 1991. Molasses-urea blocks as supplements for rabbits. *Livestock Research for Rural Development* 3(2): 13-18.
- Dobson, M. E.** 1959. Oxalate ingestion studies in the sheep. *Australian Veterinary Journal*, 35:225-233.
- Dolberg, F. and Finlayson, P.** 1995. Treated straw for beef production in China. *World Animal Review (FAO)*, No 82, p 101.
- Dolberg, F.** 1991. Adding a learning to a blueprint approach - or what a small amount of flexible money can do. *Livestock Research for Rural Development* 3(1): 1-10.

- Dolberg, F.** 1993. Development of Sustainable Livestock Technologies for Ecologically Fragile Zones in the Tropics. Report to the Project "Transfer of Sustainable Technologies". SIDA MSc course in Sustainable Livestock Production Systems, Vietnam. August 1993.
- Dolberg, F.** 1992. Progress in the utilization of urea-ammonia treated crop residues: biological and socio-economic aspects of animal production and application of the technology on small farms. *Livestock Research for Rural Development* 4(2): 20-31.
- Dolberg, F., Saadullah, M. and Hoque, M.R.** 1981. Straw treatment in a village in Noakhali district, Bangladesh. In: *Maximum Livestock Production from Minimum Land* (Editors: MG Jackson, F Dolberg, M Haque and M Saadullah) Bangladesh Agricultural University: Mymensingh pp205-224.
- Dominguez, P.L.** 1992. Feeding of sweet potato to monogastrics. In: *Roots, tubers, plantains and bananas in animal feeding*. FAO Animal Production and Health Paper No. 95. FAO, Rome. pp 217-233.
- Dominguez, P.L.** 1990. Sistema de alimentación porcina con desperdicios procesados y otros subproductos agroindustriales. In: *Taller Regional sobre "Utilización de los recursos alimenticios en la producción porcina en América Latina y el Caribe"* (Editors: Vilda Figueroa and J Ly). Instituto de Investigación Porcina, Havana, Cuba and FAO, Rome.
- Domínguez, P.L.** 1991. Sistemas de alimentación de cerdos con desperdicios alimentarios procesados y otros subproductos agroindustriales. Serie Conferencias IV. CIPAV: Cali, Colombia.
- Duong Nguyen Khang and Bui Xuan An.** 1994. Effect on *in-sacco* dry matter degradability and microbial population in the rumen of ensiling leaves from five leguminous trees with molasses or acetic acid and of adding leaves of *Enterolobium cyclocarpum* to the rice straw diet of the host animal: In: *Proceedings of National Seminar-workshop "Sustainable Livestock Production from Local Feed Resources"* (Editors: T.R. Preston, B. Ogle, Le Viet Ly and Lu Trong Hieu), Ho Chi Minh City, November 22- 27, 1993 pp 67-72.
- Elliott, R., Ferreiro, H.M., Priego, A. and Preston, T.R.** 1978. Rice polishings as a supplement in sugar cane diets: the quantities of starch (glucose polymers) entering the proximal duodenum. *Tropical Animal Production* 3:30-35.
- Ellis, J.E. and Swift, D.M.** 1988. Stability of African pastoral ecosystems: Alternate paradigms and implications for development. *Journal of Range Management* 41: 450-459.
- Esnaola, M. and Rios, C.** 1990. Hojas de "Poró" (*Erythrina poeppigiana*) como suplemento proteico para cabras lactantes *Livestock Research for Rural Development*. 2(1): 24-33.
- FAO.** 1988. Sugarcane as feed. FAO Animal Production and Health Paper No. 72. FAO, Rome.

- FAO.** 1992. Roots, tubers, plantains and bananas in animal feeding. FAO Animal Production and Health Paper No. 95. FAO, Rome.
- FAO.** 1986. Better utilization of crop residues and by-products in animal feeding: research guidelines. 2. A practical manual for research workers. FAO Animal Production and Health Paper No. 50/2. FAO, Rome pp153.
- FAO.** 1992. Legume trees and other fodder trees as protein sources for livestock . FAO Animal Production and Health Paper No 102. FAO, Rome, pp 339.
- FAO.** 1993. Livestock and improvement of pasture, feed and forage. Document COAG/93/7. Committee on Agriculture, Rome, 26 April - 4 May 1993. pp. 19.
- Ferreiro, H.M. and Preston, T.R.** 1976. Fattening cattle with sugar cane: the effect of different proportions of stalk and tops. *Tropical Animal Production* 1:178-185.
- Ferreiro, H.M., Preston, T.R. and Sutherland, T.M.** 1977. Investigation of dietary limitations on sugar cane-based diets. *Tropical Animal Production* 2:56-6.1
- Ffoulkes, D. and Preston, T.R.** 1978. Cassava or sweet potato forage as combined sources of protein and roughage in molasses based diets: effect of supplementation with soybean meal. *Tropical Animal Production* 3:186-192.
- Field, J.A. and Lettinga, G.** 1992. Toxicity of tannin compounds to micro-organisms. In: *Plant polyphenols*. (Editors: R W Hemmingway and P E Laks), Plenum Press. New York. pp. 673-692.
- Figuroa, V.** 1994. Un alimento seco para aves basado en mieles de caña de azucar. *Livestock Research for Rural Development* 6(1):74-80.
- Figuroa, V. and Ly, J.** 1990. Alimentación porcina no convencional. Colección GEPLACEA, Serie DIVERSIFICACION: México pp215.
- Filippi, B.G., Amici, A. and Machin, D.** 1992. Initial studies on the production and use of molasses blocks in the feeding of forage fed rabbits. *Journal of Applied Rabbit Research* 15: 1053-1057.
- Finlayson, P., Zhang Weixian, Gu Chuan Xue and Dolberg, F.** 1994. Economic aspects of utilising fibrous crop residues for beef production in China. *Livestock Research for Rural Development* 6(3) (In press).
- Fossati, P., Prencipe, L. and Berti, G.** 1980. Use of 3,5-dichloro-2-hydroxy-benzenesulfonic acid/4-aminophenoazone chromogenic system in direct enzymic assay of uric acid in serum and urine. *Clinical Chemistry* 26:227-231.
- Fox, M.W.** 1988. Farm animal welfare and the human diet. *The Humane Society of the United States*; Washington pp31.
- Fujihara, T., Ørskov, E.R., Reeds, P.J. and Kyle, D.J.** 1987. The effect of protein infusion on urinary excretion of purine derivatives in ruminants nourished by intragastric nutrition. *Journal of Agricultural Science (Cambridge)* 109:7-12.



- Gill, M., Bennison, J. and Wood, C.** 1992. The selection of trees for fodder. Proceedings of a British Council course: Advances in agroforestry. Bangor, University College of North Wales.
- Gomez, G.G.** 1992. Use of cassava products in pig feeding. In: Roots, tubers, plantains and bananas in animal feeding. FAO Animal Production and Health Paper No. 95. FAO: Rome pp157-168.
- Graham, N. McC.** 1983. Feeding standards: An outmoded concept in ruminant nutrition In: Recent Advances in Animal Nutrition in Australia (Editors: D J Farrell and Pran Vohra) University of New England: Armidale, Australia pp184-191.
- Gu, X.C., Fan, J.W., Li, Y., Liu, R.C., Dolberg, F. and Finlayson, P.** 1993. Effect of Cottonseed Cake and Ammoniated Straw on Performance and Intake of Calves in the Chinese Traditional Feeding System. In: Increasing Livestock Production through Utilization of Local Resources (Editor: Guo Tingshuang). Proceedings of an International Conference on Animal Production with Local Resources October 18 - 22 1993. Bureau of Animal Production and Health Ministry of Agriculture China pp. 94 - 103.
- Habit, M.A. and Saavedra, J.C. (Editors).** 1988. The current state of knowledge on *Prosopis juliflora*. In: Proceedings II International Conference on *Prosopis*. Recife, Brazil. FAO: Rome.
- Hagerman, A.E.** 1987. Radial diffusion method for determining tannin in plant extracts. *Journal of Chemical Ecology* 13(3): 437-449.
- Hagerman, A.E. and Butler, L.E.** 1989. Choosing appropriate methods and standards for assaying tannin. *Journal of Chemical Ecology* 15(6): 1795-1810.
- Hall, D.O., Munick, H.E. and Williams, R.H.** 1991. Cooling the greenhouse with bioenergy. *Nature* 353: 11-12 (5 September 1991).
- Haslam, E.** 1981. Vegetable tannins. In: *Biochemistry of plants*. (Editor: Conn, E.) Academic Press, New York. 7:52.
- Hassoun, P. and Bâ, A.A.** 1990. Mise au point d'une technique de fabrication de blocs multinutritionnels sans melasse. *Livestock Research for Rural Development*. 2(2): 23-31.
- Hecker, J.F.** 1974. Experimental surgery on small ruminants. Butterworths: London.
- Hennessy, D.W.** 1986. Supplementation to ameliorate lactational anoestrous in first-calf heifers grazing native pastures in the subtropics. *Proceedings of the Australian Society of Animal Production* 16:227-230.
- Hermans, C., Udo, H.M.J. and Dawood, F.** 1989. Cattle Dynamics and their Implications in Pabna District Bangladesh. *Agricultural Systems Elsevier* vol. 29: 371 - 384.

- Hernandez, F. and Maner, J.H.** 1965. (unpublished data cited by Clavijo and Maner, 1975. The use of waste bananas for swine feed. Proceedings of the conference on animal feeds of tropical and sub-tropical origin. Tropical Products Institute: London pp99-106).
- Ho Thi Kim Hoa, Nguyen Phuoc Nhuan and Nguyen Hoa Ly.** 1994. Production of *Spirulina* on Biodigester Effluent and Utilization as Animal Feed: In: Proceedings of National Seminar-workshop "Sustainable Livestock Production On Local Feed Resources" (Editors: T.R. Preston, B. Ogle, Le Viet Ly and Lu Trong Hieu), Ho Chi Minh City, November 22 - 27, 1993 pp105-108.
- Holmann, F., Estrada, R.D., Romero, F. and Villegas, L.E.** 1992. Technology adoption and competitiveness in small milk producing farms in Costa Rica: A case study. Livestock Research for Rural Development. 4(1): 30-54.
- Huque, Q.M.E. and Asaduzzaman, U.** 1990. Feeding Pattern of Birds (Chicken and Ducks) under Scavenging Condition and Formulation of Supplementary Ration Using the Local Ingredients. 2nd Annual Report, Poultry Production Research Division, Bangladesh Livestock Research Institute, Savar.
- IGAG.** 1988. Suelos y Bosques de Colombia. Instituto Geográfico Agustín Codazzi: Bogotá, Colombia.
- Jackson, M.G.** 1980. Who needs feeding standards? Animal Feed Science Technology 6:101-104.
- Jackson, M.G.** 1977. The alkali treatment of straws Animal Feed Science Technology 2:105-130.
- Jackson, M.G.** 1978. Treating straw for animal feeding Animal Production and Health Paper No:10 FAO:Rome.
- Jarrett, I.G.** 1948. Journal Council of Scientific and Industrial Research in Australia 21:311.
- Jayasuriya, M.C.N.** 1984. Potential for the better utilization of crop residues and agro-industrial by-products in animal feeding in the Indian sub-continent In: Guidelines for research on the better utilization of crop residues and agro-industrial by-products in animal feeding in developing countries 1. State of Knowledge (Editors : T.R. Preston, V.V. Kossila, J. Goodwin and Sheila Reed) FAO: Rome pp37-50 .
- Johnson, R.R.** 1969. Techniques and procedures for *in vitro* and *in vivo* rumen studies. In: Techniques and procedures in animal science research. American Society of Animal Science Albany:New York pp 175-196.
- Kabatange, M.A. and Shayo, C.M.** 1991. Rumen degradation of maize stover as influenced by *Leucaena* hay supplementation. Livestock Research for Rural Development, 3(2):19-22.
- Keller, M., Mitre, M.E. and Stallard, R.F.** 1990. Consumption of atmospheric methane in soils of central Panama; effects of agricultural development. Global Biogeochemical Cycles 4: 21-27.

- Khajarern, S. and Khajarern, J.M.** 1992. Use of cassava products in poultry feeding. In: Roots, tubers, plantains and bananas in animal feeding. FAO Animal Production and Health Paper No. 95. FAO: Rome pp141-156.
- Khan, F. and Preston, T.R.** 1992. Effects of restricted suckling on performance of Shorthorn and Sahiwal cows and their calves in Pakistan. *Livestock Research for Rural Development* 4(2):33-39.
- Khazaal, K., Dentinho, M.T., Ribeiro, J.M. and Ørskov, E.R.** 1993. A comparison of gas production during incubation with rumen contents *in vitro* and nylon bag degradability as predictors of apparent digestibility *in vitro* and the voluntary intake of hays. *Animal Production* 57: 105-112.
- Khazaal, K. and Ørskov, E.R.** 1994. The *in vitro* gas production technique: an investigation on its potential use with polyvinylpyrrolidone for the assessment of phenolic related anti-nutritive factors in browse. *Animal Feed Science Technology* 47:3-4.
- Khazaal, K., Boza, J. and Ørskov, E.R.** 1994. Assessment of phenolics related anti nutritive effects in Mediterranean browse: a comparison between the *in vitro* gas production technique with or without insoluble polyvinylpyrrolidone or nylon bags. *Animal Feed Science Technology* (In press).
- Kimambo, A.E. and Muya, H.M.H.** 1991. Rumen degradation of dry matter and organic matter of different banana parts. *Livestock Research for Rural Development*. 3(3):35-40.
- King, J.W.B.** 1989. New techniques in cattle breeding. In: *New Techniques in Cattle Production* (Editor: C.J.C. Phillips). Butterworths: London pp 61-66.
- Kronfeld, D.S.** 1982. Major metabolic determinants of milk volume, mammary efficiency and spontaneous ketosis in dairy cows. *Journal of Dairy Science* 65:2204-2212.
- Kumar, R.** 1992. Anti-nutritional factors. The potential risks of toxicity and the methods to alleviate them. In: *Legume trees and other fodder trees as protein source for livestock*. FAO Animal Production and Health Paper No. 102. FAO, Rome. pp 145-160.
- Kunju, P.J.G.** 1986. Urea molasses block lick: a feed supplement for ruminants. In: *Rice straw and related feeds in ruminant rations* (Editors: M.N.M. Ibrahim and J.B. Schiere) *Proceedings International Workshop, Kandy, Sri Lanka*. pp261-274.
- Larrahondo, J.E.** 1985. Productos naturales: pruebas químicas iniciales en una planta. *Guía de estudio del Departamento de Química, Universidad del Valle* 1985. 10pp.

- Le Dividich, J. and Canope, I.** 1975. Chemical composition, energy value and utilization of banana in swine feeding in tropical areas Proceedings of Seminar on the Utilization of Local Ingredients in Animal Feeding Stuffs. Kingston: Jamaica.
- Le Van Lien, Sansoucy, R. and Thien, N.** 1994. Preserving Shrimp Heads and Animal Blood with Molasses and Feeding Them as a Supplement for Pigs. In: Proceedings of National Seminar-workshop "Sustainable Livestock Production On Local Feed Resources" (Editors: T.R. Preston, B. Ogle, Le Viet Ly and Lu Trong Hieu), Ho Chi Minh City, November 22 - 27, 1993 pp 59-62.
- Lees, G. L.** 1992. Condensed tannins in some forage legumes: Their role in the prevention of ruminant pasture bloat. In: Plant Polyphenols. Synthesis, properties, significance. Edited by: Hemingway, R. W and Laks. P. E. Basic Life Sciences. Vol 59. Plenum Press. London. pp 915-934.
- Le Dividich, J., Geoffroy, F., Canope, I. and Chenost, M.** 1976. Using wastes bananas as animal feed. World Animal Review Number 20 pp. 22-30.
- Leng, R.A.** 1984. The potential of solidified molasses-based blocks for the correction of multinutritional deficiencies in buffaloes and other ruminants fed low-quality agro-industrial byproducts. In: The Use of Nuclear Techniques to Improve Domestic Buffalo Production in Asia. IAEA: Vienna pp135-150.
- Leng, R.A.** 1985. Muscle metabolism and nutrition in working animals In: Draught Animal Power for Production (Editor: J.W. Copland) ACIAR Proceedings Series No. 10, ACIAR: Canberra pp69-77.
- Leng, R.A.** 1990. Factors affecting the utilization of 'poor quality' forages by ruminant animals particularly under tropical conditions. Nutrition Research Reviews 3:277-303.
- Leng, R.A., Kempton, T.J. and Nolan, J.V.** 1977. Non-protein nitrogen and bypass proteins in ruminant diets. AMRC Review 33:1-21.
- Leng, R.A. and Preston, T.R.** 1984. Nutritional strategies for the utilization of agro-industrial byproducts by ruminants and extension of the principles and technologies to the small farmer in Asia. In: Proceedings 5th World Conference on Animal Production. Japanese Society of Zootechnical Science: Tokyo pp310-318.
- Leng, R.A., Davis, J. and Hill, M.K.** 1984. Estimation of by-pass protein based on wool growth Proceedings of the Australian Society of Animal Production 15:431-433.
- Leng, R.A. and Preston, T.R.** 1976. Sugar cane for cattle production: Present constraints, perspectives and research priorities Tropical Animal Production 1:1-22.
- Leng, R.A.** 1985. Muscle metabolism and nutrition in working animals. In: Proceedings ACIAR Workshop on 'Draught Animal Power for Production James Cook University:Townsville.

- Lien, L.V., Sansoucy, R. and Thien, N.** 1994. Preserving shrimp heads and animal blood with Molasses and feeding them as a supplement for pigs. In: Proceedings of National Seminar-workshop "Sustainable Livestock Production On Local Feed Resources" (Editors: T.R. Preston, B. Ogle, Le Viet Ly and Lu Trong Hieu), Ho Chi Minh City, November 22 - 27, 1993.
- Liener, I.** 1980. Toxic constituents of the plants foodstuffs. Second Edition. Monographs of Food Science and Technology, Academic Press, London. p502.
- Lincoln, E.** 1989. El uso de microalgas en la producción porcina. In: Sistemas intensivos para la producción animal y de energía renovable con recursos tropicales. (Editors: T.R. Preston, M. Rosales and Susana Lopez) CIPAV: Cali pp25-32.
- Lindberg, J.E. and Jansson, C.** 1989. A rapid automated analysis of allantoin in ruminant urine. Swedish Journal of Agricultural Research 19: 163-167.
- Lindsay, J.A., Mason, G.W.J. and Toleman, M.A.** 1982. Supplementation of pregnant cows with protected proteins when fed tropical forage diets. Proceedings Australian Society of Animal Production 14:67-78.
- Lipinsky, E.S. and Kresovich, S.** 1982. Sugar cane stalks for fuels and chemicals. Progress in Biomass Conversion 2:89-126.
- Lopez, J., Cuaron, I.J.A. and Vargas, Ch.D.** 1988. Sistema de alimentacion para cerdos reproductoras en el tropico basado en insumos regionales. Memorias de la Reunión de Investigación Pecuaria en Mexico DF.
- Lumpkin, T.A. and Plucknett, D.L.** 1982. *Azolla* as a green manure; use and management in crop production. Series No15, pp230, Westview Press; Boulder, Colorado, USA.
- Lux, O., Naiadoo, D. and Salonikas, C.** 1992. Improved HPLC method for the simultaneous measurements of allantoin and uric acid in plasma. Annual Clinical Biochemistry 29:674-675.
- Machado, P.** 1989. Experiencias con la utilización del bagazo de caña en la alimentación de rumiantes. In: La caña de azúcar en la alimentación animal (Editors: T R Preston and M Rosales). GEPLACEA: México.
- Maner, J.H.** 1972. La yuca en la alimentación de cerdos. Seminario sobre Sistemas de Produccion de Cerdos en America Latina. CIAT: Cali, Colombia.
- Manyuchi, M.S. and Smith, T.** 1994. Effect of treating or supplementing maize stover with urea on its utilization as feed for sheep and cattle. Animal Feed Science and Technology 49:11-23.
- Martin, P.C.** 1987. Bagazo como alimento para rumiantes. In: Sugar cane as feed. FAO Animal Production and Health Paper No. 72. FAO, Rome pp134-145.
- Marty, R.J. and Preston, T.R.** 1970. Molar proportions of the short chain volatile fatty acids (VFA) produced in the rumen of cattle given high-molasses diets Revista Cubana Ciencia Agricola 4:183-187.

- McMeniman, N.P.** 1981. The use of rumen ammonia estimations to determine when urea supplementation is necessary. Queensland Journal of Primary Industries, June 1981.
- Mena, A.** 1983. Jugo de caña de azúcar y otros recursos tropicales para la alimentación de cerdos. In: Alternativas y valor nutritivo de algunos recursos alimenticios destinados a producción animal. Informe Provisional No 16 Fundacion Internacional para la Ciencia: Stockholm pp199-204.
- Mena A** 1989 La producción de cerdos con base en la caña de azúcar. Sistemas Intensivos para la producción animal y de energía renovable con recursos tropicales (Editors: Susana Lopez, T.R. Preston and M. Rosales). CIPAV: Cali, Colombia.
- Mendoza, T.C.** 1988. Development of organic farming practices for sugarcane based farms. Paper presented during the 7th Conference of the International Federation of Organic Agriculture Movement. Ouayadougou, Burkina Fasso, Jan 2-6, 1988.
- Menke, K.H. and Steingass, H.** 1988. Estimation of the energetic feed value obtained from chemical analysis and *in vitro* gas production using rumen fluid. Animal Research and Development 28: 7-55.
- Merrill-Sands, D. and McAllister, J.** 1989. Strengthening the Integration of on-farm client-oriented Research and Experiment Station Research in National Agricultural Research Systems (NARS): Management Lessons from Nine Country Case Studies. International Service for National Agricultural Research The Netherlands.
- Meyreles, L., Pound, B. and Preston, T.R.** 1982. The use of *Leucaena leucocephala* or sugar cane tops as sources of forage in cattle diets based on molasses/urea supplemented with chicken litter and/or wheat bran cattle diets based on molasses/urea, supplemented with chicken litter and/or wheat bran Tropical Animal Production 7:92-97.
- Miah, M.H. and Sarker, R.I.** 1990. Draught power requirement and performance study of animal driven sugar cane crusher. Draught Animal News No 13:10-15. Bangladesh Agricultural University.
- Minhacienda.** 1984. Ministerio de Hacienda y Crédito Público de Colombia. Catastro 1984. Bogotá, Colombia.
- Montaldo, A.** 1977. Whole plant utilization of cassava for animal feed. In: Cassava as animal feed (Editors: B Nestel and M Graham) IDRC-095e, Ottawa pp95-106.
- Montpellier, F.A. and Preston, T.R.** 1977. Digestibility of tops, rind, derinded stalk and the entire plant of sugar cane. Tropical Animal Production 2:13-17.
- Moreno, R.A.** 1992. Recent developments in cassava agronomy. In: Roots, tubers, plantains and bananas in animal feeding. FAO Animal Production and Health Paper No. 95. FAO: Rome pp27-40.

- Moseley, W.M., McCartor, M.M. and Randel, R.D.** 1982. Effects of monensin on growth and reproductive performance of beef heifers In: Nutritional influences on reproductive development of replacement heifers (Editor: R D Randel) Technical Report 82:1 pp1-21.
- Mosier, A., Schimel, D., Valentine, D., Bronson, K. and Parton, W.** 1991. Methane and nitrous oxide fluxes in native, fertilized and cultivated grasslands. *Nature* 350: 330-332.
- Mueller-Harvey, I., McAllan, A.B., Theodorou, M.K. and Beever, D.E.** 1987. Phenolics in fibrous crop residues and plants and their effects on the digestion and utilization of carbohydrates and proteins in ruminants. In: Plant breeding and the nutritive value of crop residues. Proceedings of a workshop held at ILCA, Addis Ababa, Ethiopia. pp 97-132.
- Mueller-Harvey, I. and McAllan, A.B.** 1992. Tannins. Their biochemistry and nutritional properties. *Advances in plant cell biochemistry and biotechnology*. JAI Press. Volume 1. pp 151-217.
- Munthali, J.T.K., Jayasuriya, M.N.M., Chimbaza, T.L. and Bhattacharya, A.N.** 1991. Feeding of maize stover: physical and chemical pre-treatment and supplementation on performance of sheep and cattle. A technical report. FAO/UNDP Project MLW/87/005, Lilongwe, Malawi, mimeograph, pp.20. [p104].
- Murgueitio, E.** 1990. Intensive sustainable livestock production; an alternative to tropical deforestation. *Ambio* 19: 397-400.
- Naidoo, G., Delaitre, C. and Preston, T.R.** 1977. Effect of maize and fish meal supplements on the performance of steers fed steam-cooked bagasse and urea. *Tropical Animal Production* 2:117.
- Navas, A.** 1991. Effect of varying the fibre to sucrose ratio in the diet on rumen function and animal metabolism of faunated and defaunated sheep. M.Sc. Thesis submitted to the University of New England, Armidale, N.S.W, Australia.
- NAS.** 1973. Toxicants occurring naturally in Foods. Second Edition. National Academic of Sciences, Washington 624 p.
- NDDB.** 1982. NDDB's Centralised Activities. In: NDDB's Annual Report NDDB: Anand p33.
- NDDB.** 1989. Annual Report of the National Dairy Development Board. NDDB: Anand, India.
- Neuendorff, D.A., Rutter, L.M., Peterson, L.A. and Randel, R.D.** 1982. Effect of Lasalocid on growth and puberal development. In: Nutritional influences on reproductive development of replacement heifers (Editor: R.D. Randel) Texas A and M University Technical Report 82:1.

- Nguyen Thi Oanh.** 1994. Role of Women in the Promotion of Technology Transfer in Sustainable Livestock Production Systems in Tuyen Quang Province: In: Proceedings of National Seminar-workshop "Sustainable Livestock Production On Local Feed Resources" (Editors: T.R. Preston, B. Ogle, Le Viet Ly and Lu Trong Hieu), Ho Chi Minh City, November 22 - 27, 1993 pp127-132.
- Nguyen Thi Mui.** 1994. Effect of row spacing, planting material and mulching on yield and quality of sugar cane and soil fertility. In: Proceedings of National Seminar-workshop "Sustainable Livestock Production On Local Feed Resources" (Editors: T.R. Preston, B. Ogle, Le Viet Ly and Lu Trong Hieu), Ho Chi Minh City, November 22 - 27, 1993.
- Nguyen Vam Tu, Le Van Hung and Chan, G.** 1994. Experiences of technology transfer of the Chinese "Deep Pond and Dyke" system on two farms in the Song Be and Ho Chi Minh City provinces in the Eastern region of South Vietnam. In: Proceedings of National Seminar-workshop "Sustainable Livestock Production On Local Feed Resources" (Editors: T.R. Preston, B. Ogle, Le Viet Ly and Lu Trong Hieu), Ho Chi Minh City, November 22 - 27, 1993.
- Nguyen Hoa Ly, Tran Kim Hoa and Luu Trong Hieu.** 1994. Production of *Spirulina* and utilization as animal feed using biodigester effluent and sodium bicarbonate as substrate. In: Proceedings of National Seminar-workshop "Sustainable Livestock Production On Local Feed Resources" (Editors: T.R. Preston, B. Ogle, Le Viet Ly and Lu Trong Hieu), Ho Chi Minh City, November 22 - 27, 1993.
- Nguyen Thi Mui.** 1994. Economic evaluation of growing elephant grass, guinea grass, sugarcane and cassava as animal feed or as cash crops on bavi high land in North Vietnam. In: Proceedings of National Seminar-workshop "Sustainable Livestock Production On Local Feed Resources" (Editors: T.R. Preston, B. Ogle, Le Viet Ly and Lu Trong Hieu), Ho Chi Minh City, November 22 - 27, 1993. pp19-23.
- Nguyen Quang Suc, Dinh Van Binh, Le Viet Ly and Preston, T.R.** 1994. Studies on the Use of Dried Pressed Sugar Cane Stalk or Fresh Peeled Sugar Cane Stalk for Rabbits: In: Proceedings of National Seminar-workshop "Sustainable Livestock Production On Local Feed Resources" (Editors: T.R. Preston, B. Ogle, Le Viet Ly and Lu Trong Hieu), Ho Chi Minh City, November 22 - 27, 1993. pp63-66
- NRC.** 1988. Nutrient requirements for swine. National Academy Press; Washington, DC.
- Ocampo, A., Lozano, E. and Reyes, E.** 1990. Utilización de la cachaza de palma africana como fuente de energía en el levante, desarrollo y ceba de cerdos Livestock Research for Rural Development. 2(1): 43-50



- Ocampo, A. Castro, C. and Alfonso, L.** 1990. Determinación del nivel óptimo de proteína al utilizar cachaza de palma africana como fuente de energía en raciones para cerdos de engorde *Livestock Research for Rural Development*. 2(2): 67-76.
- Ocampo, A., Lozano, E. and Reyes, E.** 1990. Utilización de la cachaza de palma africana como fuente de energía en el levante, desarrollo y ceba de cerdos. *Livestock Research for Rural Development* 2(1): 43-50.
- Ocampo, A., Castro, C. and Alfonso, L.** 1990. Determinación del nivel óptimo de proteína al utilizar cachaza de palma africana como fuente de energía en raciones para cerdos de engorde. *Livestock Research for Rural Development* 2(2): 67-76.
- Ocampo, A.** 1992. Oil-rich fibrous residue from african oil palm as basal diet of pigs; effects of supplementation with methionine. *Livestock Research for Rural Development*, 4(2): 55-59.
- Ocampo, A.** 1994c. Efecto del nivel de pulidura de arroz en una dieta basada en el fruto entero de palma africana para el engorde de cerdos. *Livestock Research for Rural Development*. 6(2): 18Kb.
- Ocampo, A.** 1994b. Utilización del fruto de palma africana como fuente de energía con niveles restringidos de proteína en la alimentación de cerdos de engorde. *Livestock Research for Rural Development*. 6(1):1-7.
- Ocampo, A.** 1994a. Raw palm oil as the energy source in pig fattening diets and *Azolla filiculoides* as a substitute for soya bean meal. *Livestock Research for Rural Development*. 6(1):8-17.
- Ocampo, A.,** 1995. La palma africana, un recurso de alto potencial para la producción animal en el trópico. *World Animal Review (FAO)*, No 82, 1995/1.
- Ogden, Joan, Williams, R.H. and Fulmer, M.E.** 1990. Cogeneration applications of biomass gasifier/gas turbine technologies in the cane sugar and alcohol industries; Getting started with Bioenergy Strategies for Reducing Greenhouse Gas Emissions. In: *Proceedings of "Conference on Global Warming and Sustainable Development"*, Sao Paulo, Brazil June 18-20, 1990.
- Ørskov, E.R.** 1985. Evaluation of crop residues and agroindustrial byproducts using the nylon bag method. In: *Better Utilization of Crop Residues and Byproducts in Animal Feeding: Research Guidelines 1. State of knowledge* (Editors: T.R. Preston, V.L. Kossila, J. Goodwin and S. Reed). *FAO Animal Production and Health Paper No: 50*. FAO, Rome. pp 163.
- Ørskov, E.R., Grubb, D.A. and Kay, R.N.B.** 1977. Effect of postprandial glucose or protein supplementation on milk yield and composition in Friesian cows in early lactation and negative energy balance. *British Journal Nutrition* 38:397-405.

- Ørskov, E.R. and McDonald, I.** 1979. The estimation of protein degradability in the rumen from incubation measurements weighted according to rate of passage. *Journal of agricultural Science, Cambridge* 92: 499-503.
- Osorio, H., Preston, T.R. and Speedy, A.W.** 1989 The finishing of Zebu bulls on steam-hydrolysed sugar cane bagasse with different supplements. *British Society of Animal Production. Winter Meeting. Paper No. 133.*
- Ospina, Liliana, Ogle, B. and Preston, T.R.** 1994. Effect of protein supply in cassava root meal based diets on the performance of growing-fattening pigs. MSc thesis in Sustainable Livestock Systems in the Tropics. Swedish University of Agricultural Sciences: Uppsala.
- Owen, E.** 1994. Cereal crop residues as feed for goats and sheep. *Livestock Research for Rural Development.* 6(1):47-61.
- Palmer, B., Schlink, A.C., and Bray, R.A.** 1990. Tree and Shrub legumes for forage in the humid tropics. In: *Resource utilization for livestock production in Malaysia.* Edited by: Wan Zahari Mohamed, Wong Hee Kum, Engku Azahan Ahmed, and Dahalan Ismail. The Malaysian Society of Animal Production and Malaysian Agricultural Research and Development Institute. pp 138-150.
- Palmquist, D.L.** 1984. Use of fats in diets for lactating dairy cows In: *Fats in Animal Nutrition* (Editor: J. Wiseman) Butterworths:London pp357-381.
- Palmquist, D.L. and Jenkins, T.C.** 1982. Calcium soaps as a fat supplement in dairy cattle feeding. In: *Proceedings XIIth World Congress on Diseases of Cattle Amsterdam Dutch Section of the World Association for Buiatrics Utrecht, The Netherlands.* pp 487-481.
- Palo, R. T.** 1987. Phenols as defensive compounds in Birch (*Betula* spp): Implications for digestion and metabolism in browsing mammals Uppsala. Sweden. Sveriges Lantbruks universitet. 110 pp.
- Patriquin, D.G. and Moncado, T.** 1991. Cerrando el Ciclo de los Nutrientes. In: *Memorias II Seminario-Taller Internacional "Sistemas Agropecuarios Sostenibles y Desarrollo Rural para el Trópico".* (Editors: T.R. Preston, M. Rosales, H. Osorio, R. Espinel). CIPAV: Cali, Colombia.
- Patriquin, D.G.** 1982. Nitrogen fixation in sugar cane litter. *Biological Agriculture and Horticulture* 1: 39-64.
- Pentz, E.** 1969. Adaptation of the Rimini-Schrywer reaction for the measurement of allantoin in urine to the Auto-analyzer. *Analytical Biochemistry* 27:333-342.
- Perdok, H.B.** 1987. Ammoniated rice straw as a feed for growing cattle. PhD Thesis University of New England, Armidale: NSW, Australia.
- Perdok, H.B. and Leng, R.A.** 1985. Hyperexcitability in cattle fed (thermo-) ammoniated rice straw or wheat crop. In: *Proceedings of the 3rd Asian-Australasian Association of Animal Production Societies Symposium Feeding Systems of Animals in Temperate Areas* pp357-366.

- Perez, R.** 1988. The use of molasses for monogastrics. In: FAO Expert Consultation on Sugarcane as Feed. FAO Animal Production and Health Paper No. 71. FAO:Rome. pp215-234.
- Perez, R.,** 1995. Feeding pigs in the tropics. FAO Animal Production and Health Paper. FAO, Rome. (In press).
- Perez, R., Preston, T.R. and Willis, M.B.** 1968. The replacement of cereals by sugar or molasses for broilers raised on wire or litter. *Revista Cubana Ciencia Agricola* (English edition) 2:105-110.
- Perez, R.** 1995. Fish silage for feeding livestock. *World Animal Review* (FAO), No 82, 1995/1.
- Pethick, D.W. and Lindsay, D.B.** 1982. Acetate metabolism in lactating sheep. *British Journal of Nutrition* 48:319-328.
- Phan Gia Tan.** 1994. Effects on production of sugar cane and on soil fertility of leaving the dead leaves on soil surface or removing them. In: Proceedings of National Seminar-workshop "Sustainable Livestock Production On Local Feed Resources" (Editors: T.R. Preston, B. Ogle, Le Viet Ly and Lu Trong Hieu), Ho Chi Minh City, November 22 - 27, 1993.
- Porter, L.J., Hrstich, L.N. and Chan, B.C.** 1986. The conversion of procyanidins and prodelphinidins to cyanidin and delphinidin. *Phytochemistry* 25:223-230.
- Pound, B., Bordas, F. and Preston, T.R.** 1981. Characteristics of production and function of a 15 cubic metre Red-Mud PVC biogas digester. *Tropical Animal Production* 6:146-153.
- Preston, T.R. and Leng, R.A.** 1978. Sugar cane as cattle feed 2: Commercial application and economics. *World Animal Review* 28:44-48
- Preston, T.R. and Willis, M.B.** 1974. *Intensive Beef Production*. 2nd Edition, Pergamon Press Ltd: Oxford.
- Preston, T.R. and Murgueitio, E.** 1987. Tree and shrub legumes as protein sources for livestock. In: Forage legumes and other local protein sources as substitutes for imported protein meals (Editor: D. Walmsley) CTA: Wageningen and CARDI: Trinidad pp94-104.
- Preston, T.R., Carcaño, C., Alvarez, F. J. and Gutierrez, D.G.** 1976. Rice polishings as a supplement in a sugar cane diet; effect of level of rice polishings and of processing the sugar cane by derinding or chopping. *Tropical Animal Production* 1:150-160.
- Preston, T.R.** 1983. Feeding standards can be misleading. In: *Recent Advances in Animal Nutrition in Australia* (Editors: D.J. Farrell and Pran Vohra) University of New England Publishing Unit: Armidale.
- Preston, T.R.** 1986 Better utilization of crop residues and by-products in animal feeding: research guidelines 2: A practical manual for research workers. FAO Animal Production and Health Paper 50/2. FAO: Rome pp154

- Preston, T.R. and Echavarria, M.** 1991. Sustainable integrated production of livestock feed and fuel from sugar cane; the Colombian experience. In: *Power from Sugar Cane*. Conference held in Hawaii. WINROCK; Arkansas.
- Preston, T.R. and Murgueitio, E.** 1992. Strategy for sustainable livestock production in the tropics. CONDRIT Ltda: Cali pp89.
- Preston, T.R. and Leng, R.A.** 1978. Sugar cane as cattle feed 1: Nutritional constraints and perspectives *World Animal Review* 27:7-12.
- Preston, T.R. and Leng, R.A.** 1984. Supplementation of diets based on fibrous residues and byproducts In: *Straw and Other Fibrous Byproducts as Feed* (Editors: F Sundstol and E Owen). Elsevier Press: Amsterdam pp373-413.
- Preston, T.R. and Leng, R.A.** 1987. Matching Ruminant Production Systems with Available Resources in the Tropics and Subtropics. PENAMBUL Books Ltd: Armidale NSW, Australia.
- Preston, T.R., Elias, A., Willis, M.B. and Sutherland, T.M.** 1967. Intensive beef production from molasses and urea. *Nature* 216:721-724.
- Preston, T.R.** 1983. Restricted Suckling: Effects on cow and calf performance In: *Maximum Livestock Production from Minimum Land* (Edited by: C, H. Davis, T.R. Preston, M. Haque and M. Saadullah) pp54-66.
- Preston, T.R. and Leng, R.A.** 1978. Sugar cane as catt;e feed 2: Commercial application and economics *World Animal Review* 28:44-48.
- Preston, T.R.** 1972. Molasses as an energy source for cattle *World Review of Nutrition and Dietetics* 17:280-311.
- Preston, T.R., Elias, A., Willis, M.B. and Sutherland, T.M.** 1967. Intensive beef production from molasses and urea. *Nature* 216:721.
- Preston, T.R. and Vaccaro, Lucia.** 1989. Dual purpose cattle production systems. In: *New Techniques in Cattle Production* (Editor: C J C Phillips) Butterworths: UK. pp 20-32.
- Pretty, J.N. and Chambers, R.** 1992. Turning the New Leaf: New Professionalism Institutions and Policies for Agriculture. Overview Paper for the International Institute for Environment and Development/Institute of Development Studies "Beyond Farmer First Conference" October 27 - 29 1992.
- Price, M.P. and Butler, L.G.** 1977. Rapid visual estimation and spectrophotometric determination of tannin content of Sorghum grain. *Journal of Agriculture and Food Chemistry* 25: 1268-1273.
- Rangnekar, D.V., Pradhan, R.Kand Gahlot, O.P.** 1993. Surveys and farming systems research seen by a Non-Government Organization like BAIF and outside aegencies. In: *Feeding of ruminants on fibrous crop residues. Aspects of treatment, feeding, nutrient evaluation, research and extension*. Indian Council of Agricultural Research, Krishi Bhavan, New Delhi, and Department of Tropical Animal Production, Agricultural University, Wageningen, Netherlands pp 98-108.

- Rangnekar, D.V., Joshi, A.L., Badve, V.C. and Thole, N.S.** 1986. Studies on steam treatment of sugarcane bagasse for feeding of dairy cattle: a review. In: Rice straw and related feeds in ruminant rations, (Editors: Ibrahim M.N.M. and Schiere, J.B.), Proceedings of an international workshop held in Kandy, Sri Lanka, 24-28 March 1986, pp. 192-200.
- Rangnekar, S. D.** 1994. Studies on the knowledge of rural women regarding local feed resources and feeding systems developed for livestock. *Livestock Research for Rural Development*. 6(1): 27-35.
- Ravindran, V.** 1992. Preparation of cassava leaf products and their use as animal feeds. In: Roots, tubers, plantains and bananas in animal feeding. FAO Animal Production and Health Paper No. 95. FAO: Rome pp111-126.
- Ravindran, V. and Rajaguru, A.S.** 1988. Effect of stem pruning on cassava root yield and leaf growth. *Sri Lankan Journal of Agricultural Science* 25:32-37.
- Reynolds, S.G** 1988. Pastures and cattle under coconuts. In: FAO Plant Production and Protection Paper No 91. FAO, Rome, pp. 32.
- Rodriguez, H.R.** 1989. Empleo de la yuca ensilada en la engorda de cerdos en Tabasco. *Memorias de la 2nda Reunion Cientifico Forestal y Agropecuaria en el Estado de Tabasco. CIFAP-Tabasco. Mexico* p53.
- Rodríguez, J.R., Figueroa, Vi., Velasco, E. and Martínez, R.** 1994. Evaluación de un alimento seco basado en miel B de caña de azúcar para gallinas ponedoras. *Livestock Research for Rural Development* . 6(2): 21Kb.
- Rosales, M., Galindo, W., Murgueitio, E. and Larrahondo, J.** 1989. Sustancias antinutricionales en las hojas de árboles forrajeros. *Livestock Research for Rural Development* 1(1): 79-91.
- Rowe, J.B.** 1979. Homemade gasto-intestinal cannulae. *Tropical Animal Production* 4:127-133.
- Ryle, M. and Ørskov, E. R.** 1990. On milk yields and calf rearing. *Livestock Research for Rural Development* 2(3): 58-65.
- Saadullah, M.** 1984. Studies on Utilization of Rice straw by Cattle. PhD Thesis. Royal Veterinary University: Copenhagen.
- Salazar, J. and Torres, J.** 1981. La tecnología del ganado de carne. *La Ganadería de Carne en Colombia. Sociedad de Agricultores y Ganaderos del Valle del Cauca y Fondo Ganadero del Valle del Cauca. Cali, Colombia.*
- Sánchez, M.D.** 1995. Integration of livestock with perennial crops. *World Animal Review (FAO)*, No 82, p 118.
- Sansoucy, R.** 1986. The Sahel: Manufacture of molasses-urea blocks. *World Animal Review* 57:40-48.
- Sansoucy, R.** 1994. Livestock- a driving force for food security and sustainable development. FAO Working Paper. FAO: Rome pp26.
- Sansoucy, R.** 1995. Better feeds for animals: more food for humans. *World Animal Review (FAO)*, No 82, p 23.

- Sansoucy, R.** 1995. New developments in the manufacturing and utilization of multinutrient blocks. *World Animal Review* (FAO), No 82, p 99.
- Sarria, P., Solano, A. and Preston, T.R.** 1990. Utilización de jugo de caña y cachaza panelera en la alimentación de cerdos. *Livestock Research for Rural Development* 2(2): 92-99.
- Sarria, P.** 1994. Analisis comparativo de la sostenibilidad de sistemas para la producción de cerdos basados en recursos tropicales. Tesis de Maestria en Desarrollo Sostenible de Sistemas Agrarios. CIPAV: Cali.
- SIDA MSc** 1992/94. Master's programme in sustainable livestock farming systems. SUAS: Uppsala.
- Solarte, A., Dolberg, F. and Corrales, E.** 1994a. Descriptive study of the local resources used as animal feed and animal production systems in a rural community on the pacific coast of Colombia. MSc. thesis. Swedish University of Agricultural Sciences. Uppsala. Sweden.
- Solarte, A., Dolberg, F. and Corrales, E.** 1994b. Use of local carbohydrate sources and a protein supplement by big farmers in a Colombian Village in the Andean Hills. MSc. thesis. Swedish University of Agricultural Sciences. Uppsala. Sweden.
- Sourabie, K.M., Kayouli, C. and Dalibard, C.** 1995. Le traitement des fourrages grossiers à l'urée: une technique prometteuse au Niger. *World Animal Review* (FAO), No 82, p 158.
- Speedy, A.W., Seward, L., Langton, N., Du Plessis, J. and Dlamini, B.** 1991. A comparison of sugar cane juice and maize as energy sources in diets for growing pigs with equal supply of essential amino acids. *Livestock Research for Rural Development*, 3(1): 65-74.
- Speer, V.C.** 1990. Partitioning nitrogen and amino acids for pregnancy and lactation in swine: A review. *Journal of Animal Science* 68: 553-561.
- Spencer, C.M., Cai, Y., and Haslam, E.** 1988. Polyphenol complexation - some thoughts and observations. *Phytochemistry* 27:2397.
- Stephenson, R.G.A., Cobon, D., McGuigan, K.R. and Hopkins, P.S.** 1984. The measurement of rumen ammonia concentrations as an indicator of the nitrogen status of lambing ewes. *Animal Production in Australia* 15:601-603.
- Stephenson, R.C.A., Edwards, J.C. and Hopkins, P.S.** 1981. The use of urea to improve milk yield and lamb survival of merinos in a dry tropical environment. *Australian Journal of Agricultural Research* 32:497-509.
- Sundstøl, F. and Coxworth, E.M.** 1984. Ammonia treatment. In: *Straw and Other Fibrous By-Products as Feed* (Editors: F. Sundstøl and E.C. Owen) Elsevier:Amsterdam pp196-247
- Sundstøl, F. and Owen, E.C.** 1984. Straw and other fibrous by-products as feed. *Straw and Other Fibrous By-products as Feed* (Editors: F. Sundstøl and E.C. Owen) Elsevier:Amsterdam.

- Swain, T.** 1979. Tannin and lignins. In: *Herbivores, their interaction with secondary plant metabolites*. Edited by: Rozenthal, G.A. and Janzen, D.H. Academic Press. New York. pp 657-682.
- Tang, H.R., Hancock, R.A. and Covington, A.D.** 1992. Study of the composition and structure of commercial chestnut tanning agent. In: *Plant Polyphenols. Synthesis, properties, significance*. Edited by: Hemingway, R.W and Laks, P.E. Basic Life Sciences. Vol 59. Plenum Press. London. pp 221-244.
- Than Soern.** 1994. Low Cost Biodigesters in Cambodia: In: (Editors: T.R. Preston, B. Ogle, Le Viet Ly and Lu Trong Hieu), Ho Chi Minh City, November 22 - 27, 1993. pp109-112
- Theodorou, M.K., Willians, B.A., Dhanoa, M.S., McAllan, A.B. and France, J.** 1994. A simple gas production kinetics method using a pressure transducer to determine the fermentation kinetics of ruminant feeds. *Animal Feed Science and Technology* 48:185-197.
- Throckmorton, J.C. and Leng, R.A.** 1984. Effect of by-pass protein and by-pass starch on milk yield and bodyweight gain in grazing dairy cows. *Animal Production in Australia* 15:628-630.
- Ugarte, J. and Preston, T.R.** 1972. Rearing dairy calves by restricted suckling once or twice daily on milk production and calf growth. *Revista Cubana Ciencia Agricola* 6:173-182.
- Udedibie, A.B.I.** 1991. Relative effects of heat and urea-treated Jackbean (*Canavalia ensiformis*) and Swordbean (*Canavalia gladiata*) on the performance of laying hens. *Livestock Research for Rural Development*, Volume 3, Number 3: 69-79.
- Valdez, R.E., Alvarez, F.J., Ferreiro, M.H., Guerra, F., Lopez, J., Priego, A., Blackburn, T.H., Leng, R.A. and Preston, T.R.** 1977. Rumen function in cattle fed on sugar cane. *Tropical Animal Production* 2:260-272.
- Van Soest, P.J.** 1982. *Nutritional ecology of the ruminant*. O and B Books:Corvallis, Oregon.
- Vargas, J.E. and Rivera, J.B.** 1994. Efecto del bloque multinutricional sobre el comportamiento productivo y reproductivo en ovejas africanas. *Livestock Research for Rural Development*. 6(2): 20Kb.
- Vargas, J.E., Rodríguez, O., Murgueitio, E and Preston, T.R.** 1994. Efecto del nivel de oferta del tallo prensado de caña de trapiche sobre el consumo y el ecosistema ruminal en ovejas africanas. *Livestock Research for Rural Development*. 6(2): 12Kb.
- Verbic, J., Chen, X.B., MacLeod, N.A. and Ørskov, E.R.** 1990. Excretion of purine derivatives by ruminants: effect of microbial nucleic acid infusion on purine derivative excretion by steers. *Journal of agricultural Science (Cambridge)* 114:243-248.

- Wang, T.C. and Fuller, M.F.** 1989. The optimum dietary amino acid pattern for growing pigs. 1. Experiments by amino acid deletion. *British Journal of Nutrition* 62:77-89.
- Weston, R.H.** 1966. The effect of level of feeding on acetate tolerance in the sheep. *Australian Journal Agricultural Research* 17:933-937.
- Whitelaw, F.G. and Preston, T.R.** 1963. The nutrition of the early-weaned calf. III. Protein solubility and amino acid composition as factors affecting protein utilization. *Animal Production* 5:131-140.
- Wong You Cheong, Y., d'Espaignet, J.T., Deville, P.J., Sansoucy, R. and Preston, T.R.** 1974. The effect of steam treatment on cane bagasse in relation to its digestibility and furfural production. *Proceedings of the 15th Congress of ISSCT (South Africa) (International Section) 3: 1887-1894.* Hayne and Gibson: Durban.
- Young, J.E. and Conway, C.F.** 1942. On the estimation of allantoin by the Rimini-Schryver reaction. *Journal of Biological Chemistry* 142:839-853.
- Zelter, S.Z., Leroy, F. and Tissier, J. P.** 1990. Protection des protéins alimentaires contre la désamination bactérienne dans le rumen. *Annales de Biologie Animale Biochimie Biophysique* 10:123-141.
- Zerbini, E. and Gameda, T.** 1994. Effect of work on dry matter intake, milk production and reproduction in multipurpose cows fed low quality roughage. *Livestock Research for Rural Development*. 6(2): 42Kb.